

ZXCT1030
HIGH-SIDE CURRENT MONITOR WITH COMPARATOR

Description

The ZXCT1030 is a high side current sense monitor containing an internal reference and comparator with a non-latching output. Using this device eliminates the need to disrupt the ground plane when sensing a load current.

The wide input voltage range of 20V down to as low as 2.2V make it suitable for a range of applications. Dynamics and supply current are optimized for the processing of fast pulses, associated with switch mode applications.

Pin Assignments

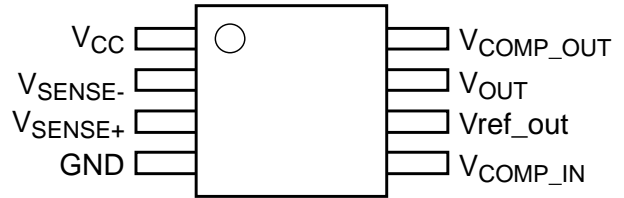

Features

- Low cost, accurate high-side current sensing
- Output voltage scaling
- Up to 18V output
- 2.2V - 20V supply range
- Voltage reference on chip
- Comparator on chip
- SO8 package

Applications

- Battery chargers
- Electronic fuse
- DC motor control
- Over current monitor
- Power management
- Inrush current limiting

Typical Application Circuit

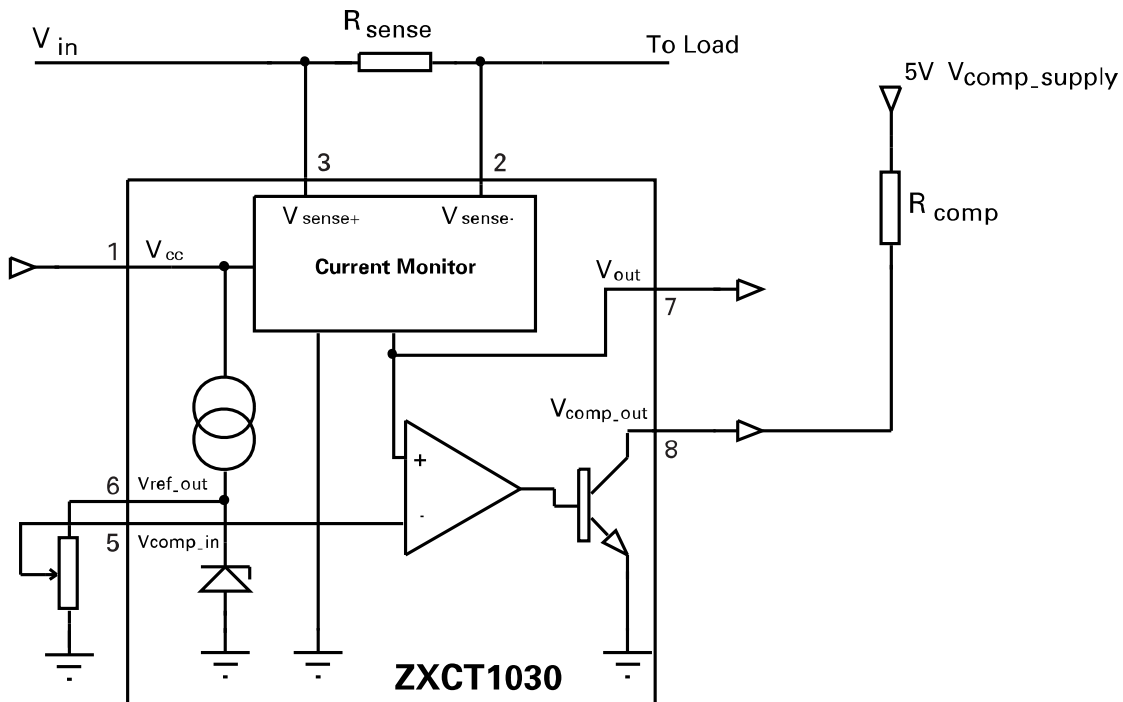

Pin Description

Pin Name	Function
V _{CC}	Supply voltage
V _{SENSE-}	Negative sense input
V _{SENSE+}	Positive sense input
GND	Ground
V _{COMP_IN}	Comparator input, usually a ratio of the reference or other control signal
V _{REF_OUT}	Reference output
V _{OUT}	Current monitor output voltage
V _{COMP_OUT}	Open collector comparator output

Absolute Maximum Ratings

Parameter	Rating	Unit
Voltage on any pin	-0.6 and V _{CC} +0.6	V
Operating Temperature	-40 to 85	°C
Storage Temperature	-55 to 125	°C
Package Power Dissipation	(T _{AMB} = 25)	°C
SO8	700	mW

Recommended Operating Conditions

Parameter	Min	Max	Units
V _{CC}	2.2	20	V
V _{SENSE+}	2.2	V _{CC}	V
V _{SENSE} ^(a)	10	500	mV
V _{OUT}	0	V _{SENSE-} -1V	V
V _{COMP_IN}	0.005	10	V
T _{AMB}	-40	85	°C

Electrical Characteristics (ZXCT1030N8) – Test conditions $T_{AMB} = 25^{\circ}\text{C}$, $V_{IN} = V_{CC} = 15\text{V}$, $R_{COMP} = 10\text{k}\Omega$,

$V_{COMP_SUPPLY} = 5\text{V}$ unless otherwise stated.

Symbol	Parameter	Condition	Min.	Typ.	Max.	Unit
V_{CC}	V_{CC} Range		2.2		20	V
V_{SENSE+}	Sense+ Range		2.2		V_{CC}	
V_{OUT}	Output Voltage	$V_{SENSE} = 0$ $V_{SENSE} = 10$ $V_{SENSE} = 30$ $V_{SENSE} = 50$ $V_{SENSE} = 100$ $V_{SENSE} = 500$	0 88 284 480 970 4500	2 100 300 500 1000 5000	10 112 316 520 1030 5500	mV
R_{OUT}	Output Resistance	$V_{SENSE-} = 15\text{V}$, $V_{OUT} = 1\text{V}$	1.2	1.5	1.8	k Ω
$\frac{V_{OUT}}{T_C}$	V_{OUT} Temperature Coefficient			30		ppm/ $^{\circ}\text{C}$
I_{CC}	Supply Current	$V_{SENSE-} = 15\text{V}$	170	270	350	μA
I_{SENSE+}	V_{SENSE+} Input Current			48	90	μA
I_{SENSE-}	V_{SENSE-} Input Current	$V_{SENSE-} = 14.9\text{V}$		70	220	nA
$V_{CM(MIN)}^{(B)}$	Minimum Active Common Mode Voltage	$V_{CC} = 15\text{V}$ $V_{COMP_SUPPLY} = 5\text{V}$ $V_{COMP_IN} = V_{REF}$ $V_{SENSE} = 10\text{mV}$	2.8			V
A_{CC}	Accuracy	$V_{SENSE} = 100\text{mV}$	-3		3	%
GAIN	V_{OUT}/V_{SENSE}	$V_{SENSE} = 100\text{mV}$	9.7	10.0	10.3	
BW	Bandwidth	$V_{SENSE} = 10\text{mVp-p}$ $V_{SENSE} = 100\text{mVp-p}$		3 6		MHz
COMPARATOR						
V_{COMP_IN}	Input Voltage		0.005		10	V
V_H	Hysteresis			15		mV
I_B	Input Bias		5	80	150	nA
T_D	Propagation Delay			100		ns
V_{OL}	Output Voltage Low		30	150	200	mV
V_{OH}	Output Voltage High				V_{COMP_SUPPLY}	
I_{OL}	Output Sink Current	$V_{ol} = 0.4\text{V}$	2			mA
I_{OH}	Output High Leakage Current				1.0	μA
Voltage Reference						
V_{REF}		Reference Current = +300 μA to -5 μA	1.200	1.240	1.280	V
Delta V_{REF}	Change in V_{REF}	SOURCE 5 μA to SINK 300 μA		10		mV
T_C				30		ppm/ $^{\circ}\text{C}$
PSR	Supply Rejection			0.01		%/V

Notes: (a) $(V_{SENSE+}) - (V_{SENSE-})$
(b) Level of V_{SENSE+} where comparator output defaults to 'off'.

Typical Application Circuits

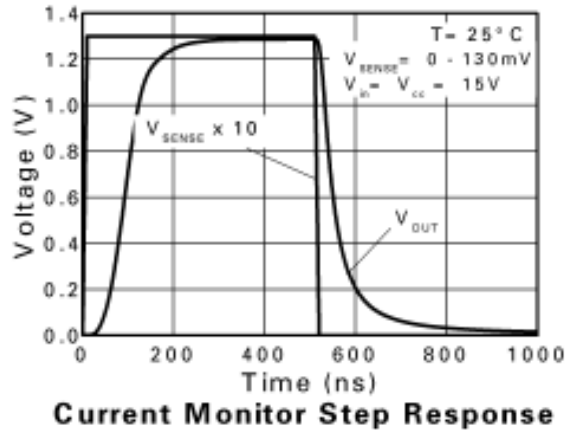
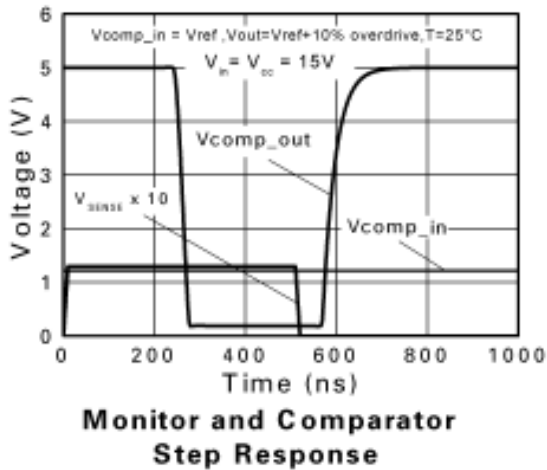
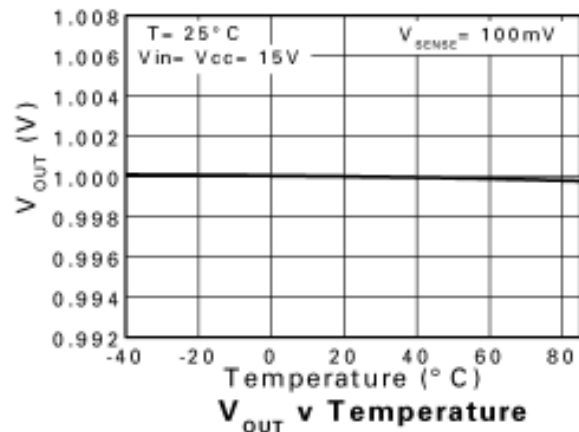
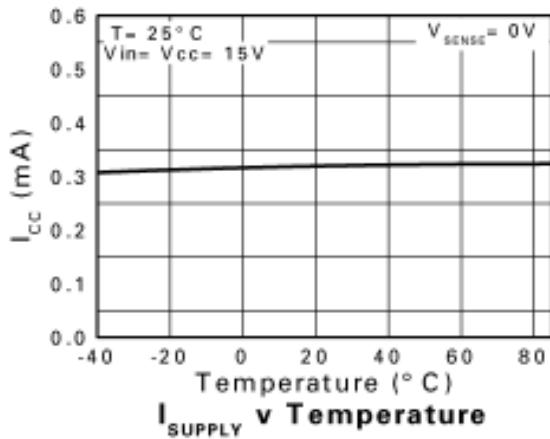
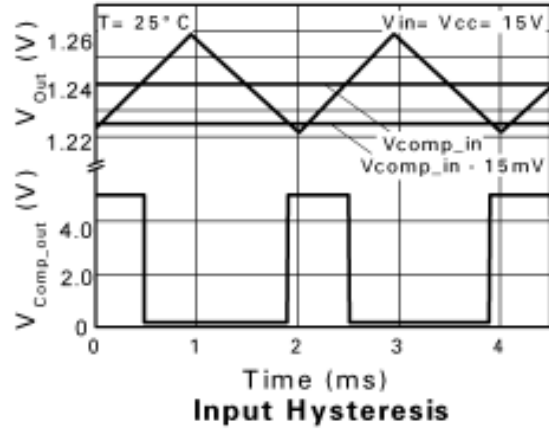
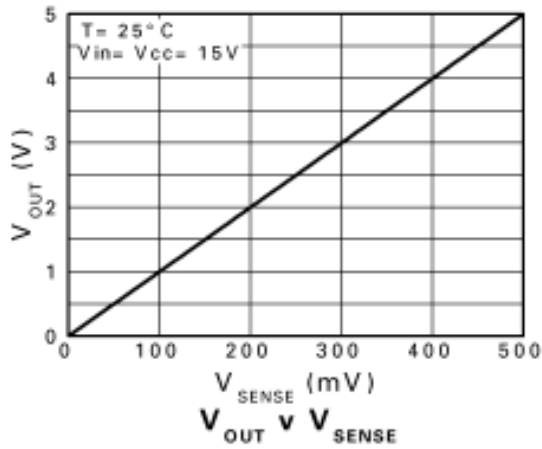

Voltage output current monitor

Referring to the block diagram, the current monitor takes the small voltage developed across the sense resistor (V_{SENSE}) and transfers it from the large common mode supply voltage to a ground referenced signal with a gain of 10. The sense input common mode range is 2.2V to 20V. In this range, a linear output voltage is delivered.

Reference

The bandgap reference allows the comparator to compare the translated V_{SENSE} with threshold value chosen by the user which can be any voltage from 0 to 1.24V, configured by two external resistors which forms V_{COMP_IN} .

The output current which can be drawn from the comparator reference (I_{REF} source) is limited to 5 μ A, making potentiometers $\geq 250k\Omega$ suitable for setting a threshold level. Where a lower potentiometer resistor value is used, an additional resistor value should be inserted between V_{REF} and V_{CC} to maintain sufficient current for the reference. (as shown in Figure 1).

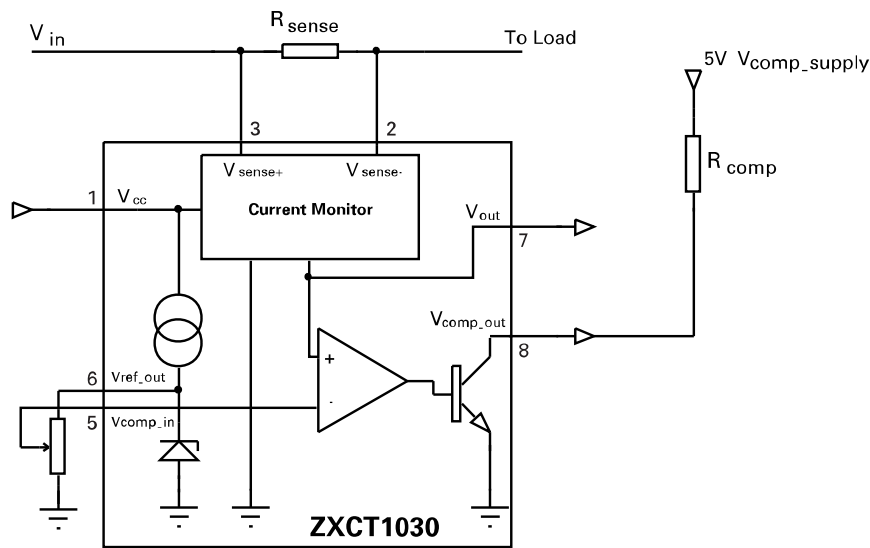

Figure 1: External Resistor for Reference Level

The voltage reference has a maximum current sink capability. This magnitude of current will be influenced by the value of R_1 which is inserted between V_{REF} and V_{CC} . The value of current flowing through R_1 can be expressed as:

$$I = (V_{CC} - V_{REF}) / R_1$$

Comparator

The open collector output is active low and is asserted when $V_{SENSE} \times 10 (V_{OUT}) > V_{COMP_IN}$. It can be connected to any voltage rail up to V_{IN} via a pull-up resistor. Suggest values for the resistor are in the range of 10-100k Ω .

In the case where high load currents or a short circuit occurs, thus reducing the common mode signals (V_+ , V_-) typically below 2.2V, the comparator will default to the asserted state. This can eliminate a closed loop system 'latch-up' condition, allowing the controller to remove the applied power.

Stability

To ensure stable operation of the ZXCT1030, it is recommended a decoupling capacitor is placed across the V_{CC} and ground connections. A ceramic 10 μ F will be adequate.

Ordering Information*

Device	Status(*)	Package	Device Marking	Reel Size (inches)	Tape Width (mm)	Quantity Per reel
ZXCT1030X8TA	Obsolete	MSOP8	ZXCT1030	7	12	1000
ZXCT1030N8TA	Active	SO8	ZXCT1030	7	12	500

Notes: *ZXCT1030X8TA is obsolete for more device information please check our obsolete products search on diodes website

Package Outline – SO8

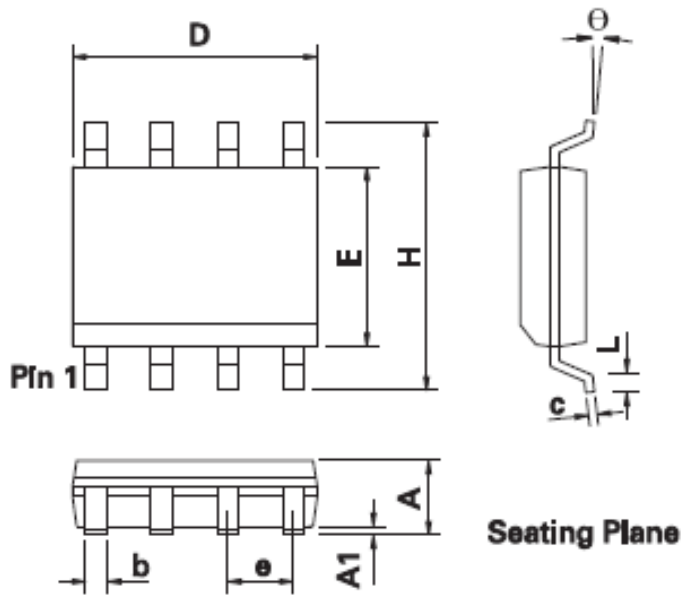

DIM	Inches		Millimeters		DIM	Inches		Millimeters	
	Min.	Max.	Min.	Max.		Min.	Max.	Min.	Max.
A	0.053	0.069	1.35	1.75	e	0.050 BSC		1.27 BSC	
A1	0.004	0.010	0.10	0.25	b	0.013	0.020	0.33	0.51
D	0.189	0.197	4.80	5.00	c	0.008	0.010	0.19	0.25
H	0.228	0.244	5.80	6.20	theta	0°	8°	0°	8°
E	0.150	0.157	3.80	4.00	h	0.010	0.020	0.25	0.50
L	0.016	0.050	0.40	1.27	-	-	-	-	-

Note: Controlling dimensions are in inches. Approximate dimensions are provided in millimeters

IMPORTANT NOTICE

DIODES INCORPORATED MAKES NO WARRANTY OF ANY KIND, EXPRESS OR IMPLIED, WITH REGARDS TO THIS DOCUMENT, INCLUDING, BUT NOT LIMITED TO, THE IMPLIED WARRANTIES OF MERCHANTABILITY AND FITNESS FOR A PARTICULAR PURPOSE (AND THEIR EQUIVALENTS UNDER THE LAWS OF ANY JURISDICTION).

Diodes Incorporated and its subsidiaries reserve the right to make modifications, enhancements, improvements, corrections or other changes without further notice to this document and any product described herein. Diodes Incorporated does not assume any liability arising out of the application or use of this document or any product described herein; neither does Diodes Incorporated convey any license under its patent or trademark rights, nor the rights of others. Any Customer or user of this document or products described herein in such applications shall assume all risks of such use and will agree to hold Diodes Incorporated and all the companies whose products are represented on Diodes Incorporated website, harmless against all damages.

Diodes Incorporated does not warrant or accept any liability whatsoever in respect of any products purchased through unauthorized sales channel.

Should Customers purchase or use Diodes Incorporated products for any unintended or unauthorized application, Customers shall indemnify and hold Diodes Incorporated and its representatives harmless against all claims, damages, expenses, and attorney fees arising out of, directly or indirectly, any claim of personal injury or death associated with such unintended or unauthorized application.

Products described herein may be covered by one or more United States, international or foreign patents pending. Product names and markings noted herein may also be covered by one or more United States, international or foreign trademarks.

LIFE SUPPORT

Diodes Incorporated products are specifically not authorized for use as critical components in life support devices or systems without the express written approval of the Chief Executive Officer of Diodes Incorporated. As used herein:

A. Life support devices or systems are devices or systems which:

1. are intended to implant into the body, or
2. support or sustain life and whose failure to perform when properly used in accordance with instructions for use provided in the labeling can be reasonably expected to result in significant injury to the user.

B. A critical component is any component in a life support device or system whose failure to perform can be reasonably expected to cause the failure of the life support device or to affect its safety or effectiveness.



Customers represent that they have all necessary expertise in the safety and regulatory ramifications of their life support devices or systems, and acknowledge and agree that they are solely responsible for all legal, regulatory and safety-related requirements concerning their products and any use of Diodes Incorporated products in such safety-critical, life support devices or systems, notwithstanding any devices- or systems-related information or support that may be provided by Diodes Incorporated. Further, Customers must fully indemnify Diodes Incorporated and its representatives against any damages arising out of the use of Diodes Incorporated products in such safety-critical, life support devices or systems.

Copyright © 2010, Diodes Incorporated

www.diodes.com

Looking for pricing, stock, or lifecycle information?

Click below to explore more details on WIN SOURCE:

-  [View ZXCT1030N8TA on WIN SOURCE](#)
-  [Diodes Incorporated Information](#)

Optimize Your Supply Chain with WIN SOURCE Solutions

-  Global Sourcing Solution
-  Obsolete Management
-  Cost Control Management
-  Shortage Management
-  Alternative Solution
-  Excess Inventory Management