



**THE DATASHEET OF
ZXCT1012ET5TA**



Description

The ZXCT1012 is a high side current sense monitor. Using this type of device eliminates the need to disrupt the ground plane when sensing a load current.

The ZXCT1012 takes the voltage developed across a small value resistor and translates it into a proportional output current. A user defined output resistor scales the output current into a ground referenced voltage.

The ZXCT1012 has the accuracy specification of the ZXCT1010 but in TSOT25.

A minimum operating current of just 3.5µA, combined with its TSOT25 package make it suitable for portable battery equipment where size and current consumption are critical.

The wide input voltage range down to as low as 2.5V make it suitable for a wide range of applications requiring direct operation from a battery.

Pin Assignments

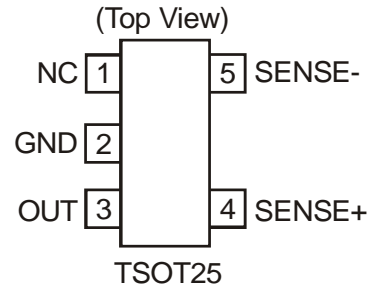

Features

- 2.5V to 20V supply range
- 3.5µA quiescent current
- Current output - user set gain
- Thin package - TSOT25
- Temperature range -40 to 85°C

Applications

- Battery fuel gauge
- Battery chargers
- Overcurrent monitor
- Power management

Typical Application Circuit

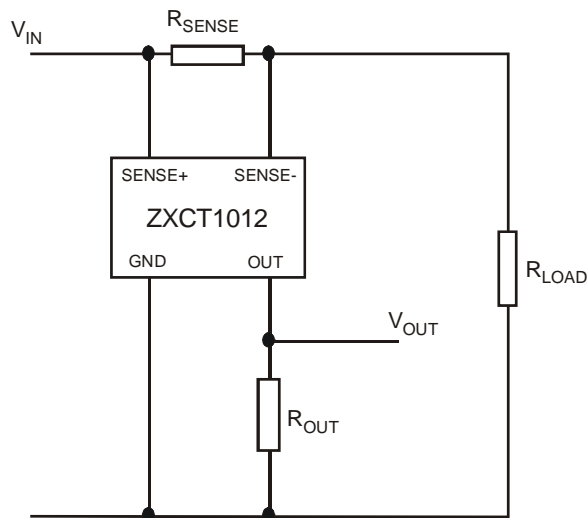

Pin Descriptions

Pin	Name	Description
1	N/C	No connection
2	GND	Ground connection
3	OUT	Output current pin. Current generated due to a difference voltage between V_{SENSE+} and V_{SENSE-} flows out of this pin. A suitable value resistor connected to ground creates an output voltage. The maximum voltage out of this pin will be $V_{SENSE-} - 1.5V$.
4	SENSE+	This pin should be connected to the rail whose current is being measured and also provides power to internal circuitry. It is the positive input of the current monitor and has an input range from 20V down to 2.5V. The current through this pin varies with differential sense voltage.
5	SENSE-	This is the negative input of the current monitor and has an input range from 20V down to 2.5V.

Absolute Maximum Ratings ($T_A = 25^\circ C$)

Description	Rating	Unit
V_{SENSE+} Max.	20	V
Voltage on any pin(relative to GND pin)	-0.6 and $V_{SENSE+} +0.5$	V
V_{SENSE} (Note 1)	-0.15 to 3	V
Ambient Operating Temperature Range	-40 to 85	$^\circ C$
Storage Temperature	-55 to 150	$^\circ C$
Maximum Junction Temperature	150	$^\circ C$
Power Dissipation ($T_A = 25^\circ C$)	300 (De-rate to 0 at 150 $^\circ C$)	mW

Package (Note 2)	$R_{\theta JA}$	P_{DISS} @ 25 $^\circ C$
TSOT25	250 $^\circ C/W$	500mW

Recommended Operating Conditions

Symbol	Parameter	Min.	Max.	Units
V_{IN}	Sense+ range	2.5	20	V
T_A	Ambient temperature range differential	-40	85	C
V_{SENSE}	Sense voltage	10	2500	mV
V_{OUT}	Output voltage swing	0	$V_{SENSE-} -15$	V

Operation above the absolute maximum rating may cause device failure.

Operation at the absolute maximum ratings, for extended periods, may reduce device reliability.

- Notes: 1. V_{SENSE} is defined as the differential voltage between the SENSE+ and SENSE- pins. ($V_{SENSE} = V_{SENSE+} - V_{SENSE-}$)
 2. Mounted on 30mm x 16mm x 1.1mm FR4 board with 1oz copper.

Electrical Characteristics ($T_A = 25^\circ\text{C}$, $V_{IN} = V_{SENSE+} = 5\text{V}$; unless otherwise specified)

Symbol	Parameter	Conditions	Limits			Unit
			Min.	Typ.	Max.	
I_{OUT}	Output Current	$V_{SENSE} = 0\text{V}$	0	0.3	15	μA
		$V_{SENSE} = 10\text{mV}$	85	100	115	μA
		$V_{SENSE} = 40\text{mV}$	380	400	420	μA
		$V_{SENSE} = 100\text{mV}$	0.975	1.00	1.025	mA
		$V_{SENSE} = 200\text{mV}$	1.95	2.00	2.05	mA
I_Q	Ground Pin Current	$V_{SENSE} = 0\text{V}$		3.5	8	μA
I_{SENSE-}	SENSE- Pin Input Current				100	nA
A_{CC}	Accuracy		-2.5		2.5	%
G_m	Transconductance, I_{OUT}/V_{SENSE} (Note 3)	$R_{SENSE} = 0.1\text{V}$ $V_{SENSE} = 200\text{mV}$		10		mA/V
T_C	Temperature Coefficient	$V_{SENSE} = 200\text{mV}$ $T_A = 0 \text{ to } 50^\circ\text{C}$ (Note 3)		500		$\text{ppm}/^\circ\text{C}$
BW	Bandwidth	$C_L = 5\text{pF}$		300		kHz
		$R_{OUT} = 1\text{k}\Omega$	$V_{SENSE} = 10\text{mV}$ $V_{SENSE} = 100\text{mV}$	2		MHz
CMRR (Note 4)	Common Mode Rejection Ratio	$V_{SENSE} = 100\text{mV}$, $R_{OUT} = 1\text{k}\Omega$ $V_{IN} = 2.5\text{V to } 20\text{V}$		80		dB

Notes: 3. Temperature dependent measurements are extracted from characterisation and simulation results.
 4. With the ZXCT1012 using SENSE+ as its power supply pin, common mode rejection cannot be distinguished from power supply rejection.

Typical Characteristics

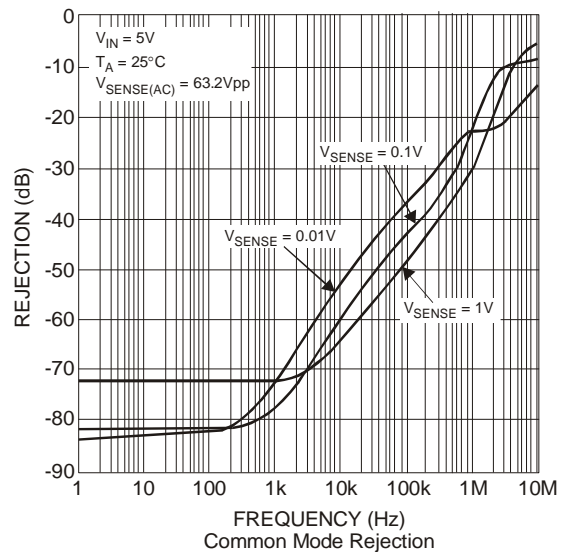
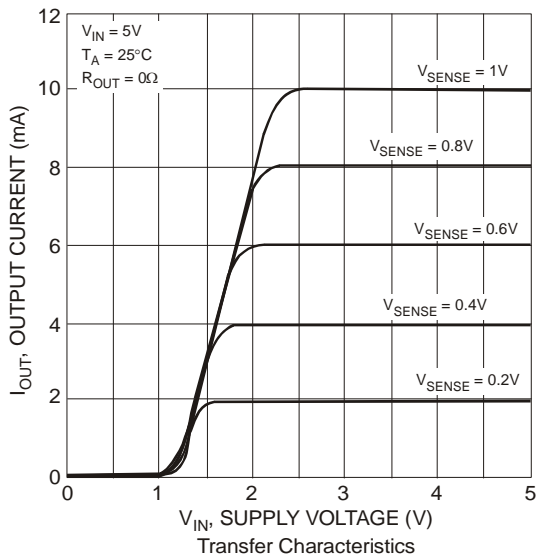
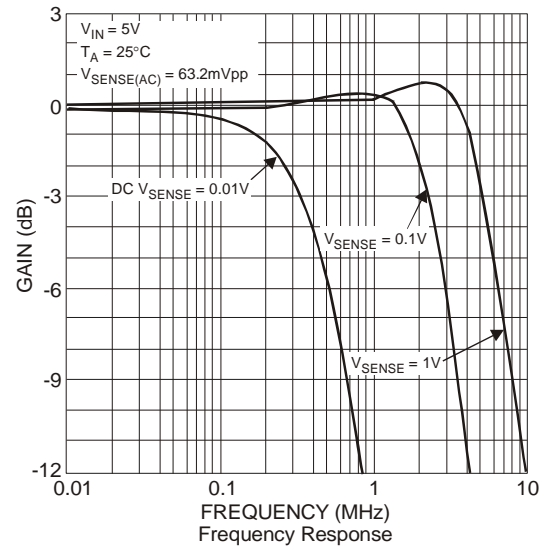
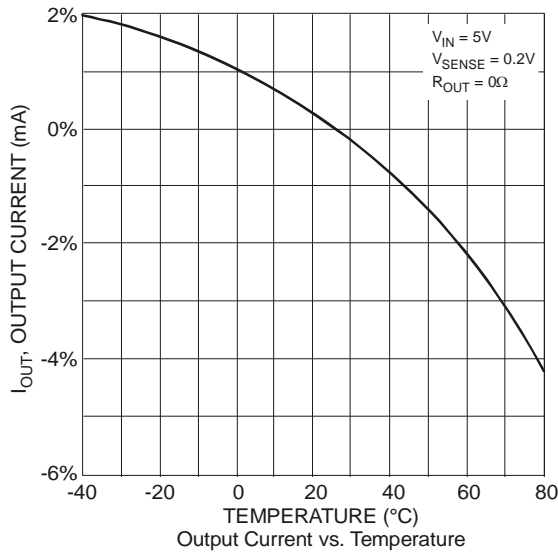
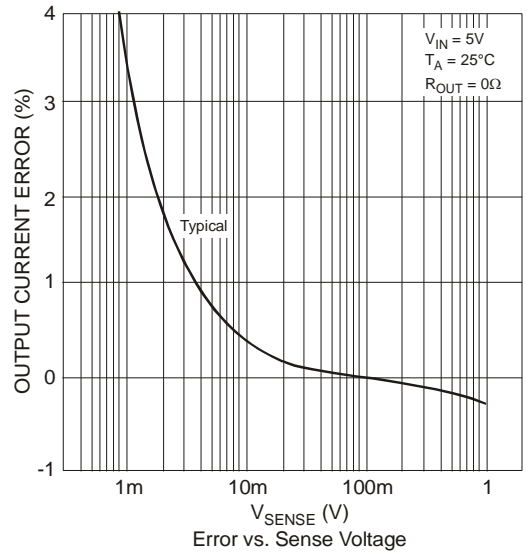
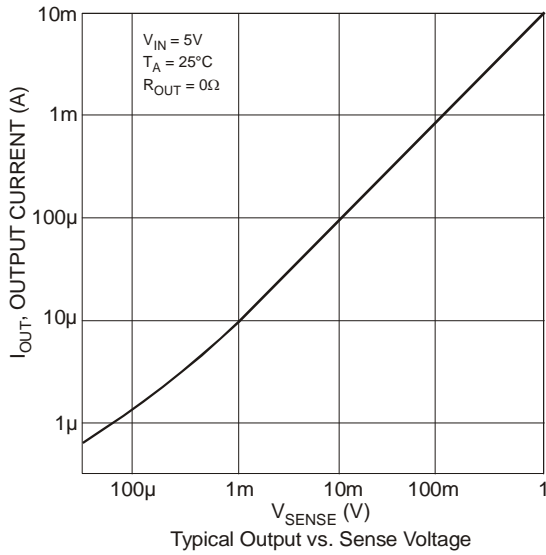

Applications Information

The ZXCT1012 current monitor works by converting the voltage developed across a small sense resistor into a current on the out pin. In reality it is a voltage to current converter. This output current can be converted into a voltage simply by passing it through a resistor (R_{OUT}) to ground.

The current monitor has a transconductance of 10mA/V. But the overall amplifying conversion is affected by both the R_{SENSE} and R_{OUT} .

The gain equation of the ZXCT1012 is:

$$V_{OUT} = I_L \times R_{SENSE} \frac{R_{OUT}}{100}$$

For best performance R_{SENSE} should be connected as close to the SENSE+ (and SENSE-) pins; which minimizes any series resistance with R_{SENSE} and potential for interference pickup.

When choosing appropriate values for R_{SENSE} a compromise must be reached between in-line signal loss (including potential power dissipation effects) and small signal accuracy.

Higher values for R_{SENSE} gives better accuracy at low load currents by reducing the inaccuracies due to internal offsets. For best operation the ZXCT1012 has been designed to provide best performance with V_{SENSE} of the order of 40mV to 200mV.

Current monitors are single supply devices which means they tend to saturate at very low sense voltages. However it does mean the output can never go negative. Also the output can never change direction (monotonic). This is important if the current monitor is used in a control loop.

As the sense voltage is reduced the output will tend to saturate as the input offset voltage starts to have greater effect. It is recommended to have a minimum sense voltage of 10mV to minimize linearity errors. Diodes has specified the output voltage at V_{SENSE} of 10mV, 40mV, 100mV and 200mV; which is the recommended sense voltage range.

The maximum differential input voltage, V_{SENSE} , is 2.5V; however this will cause large output currents to flow increasing power dissipation in the chip. The sense voltage can be increased further, without damaging the ZXCT1012, by the inclusion of a resistor, R_{LIM} , between SENSE- pin and the load. Typical values around 10k Ω . See figure below.

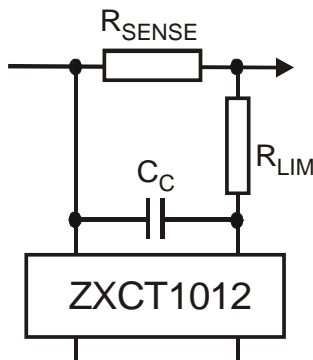

If large reverse currents are expected then the resistor, R_{LIM} , will provide protection from exceeding absolute maximum ratings.

A suitable value for R_{LIM} can be determined from:

$$R_{LIM} = \frac{V_{SENSE(REF)}}{5mA}$$

Where $V_{SENSE(REV)}$ is the maximum expected reverse sense voltage generated.

Applications Information (cont.)

The following lines describe how to scale a load current to an output voltage.

$$V_{\text{SENSE}} = R_{\text{SENSE}} \times I_{\text{LOAD}} \quad \text{equation (1)}$$

$$I_{\text{OUT}} = 10\text{mA/V} \times V_{\text{SENSE}} \quad \text{equation (2)}$$

$$V_{\text{OUT}} = I_{\text{OUT}} \times R_{\text{OUT}} \quad \text{equation (3)}$$

Design example

In the circuit below a 1A current is to be represented by a 100mV output voltage (V_{OUT}):

A) To be within recommended values choose the value of R_{SENSE} to give:

$50\text{mV} > V_{\text{SENSE}} > 200\text{mV}$ at full load.

For example set $V_{\text{SENSE}} = 100\text{mV}$ at 1.0A.

From equation (1)

$$R_{\text{SENSE}} = 0.1\text{V}/1.0\text{A} = 0.1\Omega$$

B) Now choose R_{OUT} to give:

$V_{\text{OUT}} = 100\text{mV}$, when $V_{\text{SENSE}} = 100\text{mV}$.

From equation (2)

$$I_{\text{OUT}} = 10\text{mA/V} \times 0.1 = 1\text{mA}$$

Rearranging equation (3) for R_{OUT} gives:

$$R_{\text{OUT}} = V_{\text{OUT}}/I_{\text{OUT}} = 0.1/0.001 = 100\Omega$$

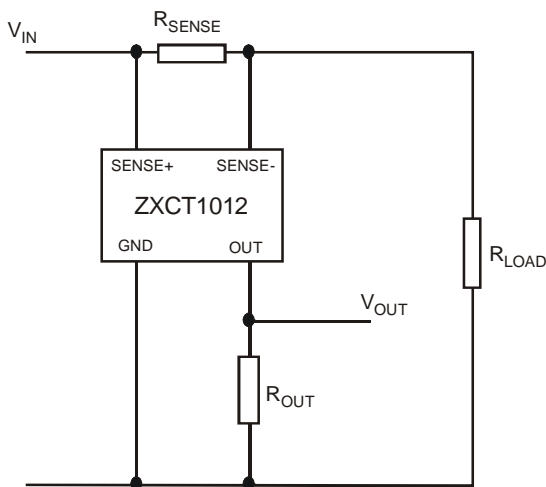

$$= 0.1 / (0.1 \times 0.01) = 100\Omega$$

Typical Circuit Application

Where R_{LOAD} represents any load including DC motors, a charging battery or further circuitry that requires monitoring, R_{SENSE} can be selected on specific requirements of accuracy, size and power rating.

Power Dissipation

The maximum allowable power dissipation of the device for normal operation (P_{MAX}), is a function of the package junction to ambient thermal resistance (θ_{JA}), maximum junction temperature (T_{JMAX}), and ambient temperature (T_A), according to the expression:

$$P_{MAX} = (T_{JMAX} - T_A) / \theta_{JA}$$

The device power dissipation, P_D is given by the expression:

$$P_D = I_{OUT} \cdot (V_{IN} - V_{OUT}) \text{ watts}$$

Care must be taken when using this device at large input voltages and large sense voltages to prevent too much power dissipation.

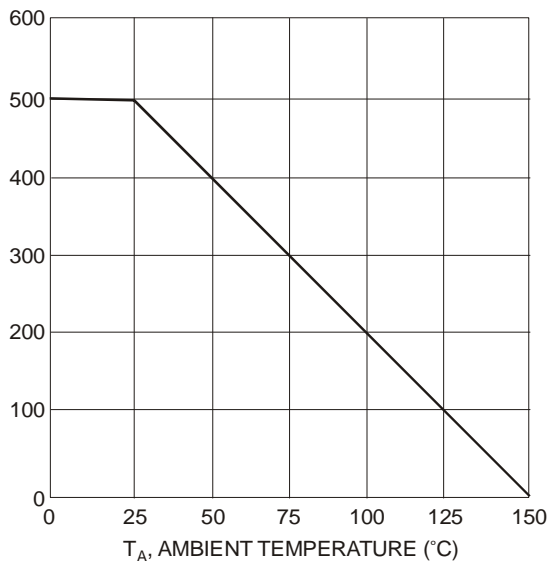

$$V_{IN} = 20V \quad V_{SENSE} = 2.5V$$

$$R_{OUT} = 100\Omega$$

$$I_{OUT} = 2.5 \times 0.01 \\ = 25mA$$

$$V_{OUT} = I_{OUT} \times R_{OUT} \\ = 25mA \times 100\Omega \\ = 2.5V$$

$$\therefore P_D = 25mA (20 - 2.5)V \\ = 438mW$$

Ordering Information

Device	Package	Marking	Reel Size	Quantity
ZXCT1012ET5TA	TSOT25	1012	7	3000 Tape & Reel

Package Outline Dimensions (All Dimensions in mm)

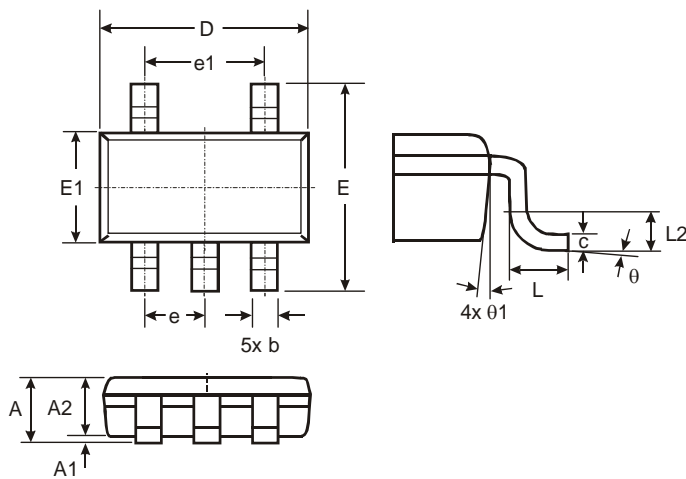

TSOT25			
Dim	Min	Max	Typ
A	-	1.00	-
A1	0.01	0.10	-
A2	0.84	0.90	-
D	-	-	2.90
E	-	-	2.80
E1	-	-	1.60
b	0.30	0.45	-
c	0.12	0.20	-
e	-	-	0.95
e1	-	-	1.90
L	0.30	0.50	-
L2	-	-	0.25
θ	0°	8°	4°
$\theta 1$	4°	12°	-
All Dimensions in mm			

Suggested Pad Layout

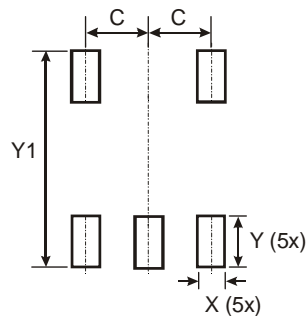

Dimensions	Value (in mm)
C	0.950
X	0.700
Y	1.000
Y1	3.199

IMPORTANT NOTICE

DIODES INCORPORATED MAKES NO WARRANTY OF ANY KIND, EXPRESS OR IMPLIED, WITH REGARDS TO THIS DOCUMENT, INCLUDING, BUT NOT LIMITED TO, THE IMPLIED WARRANTIES OF MERCHANTABILITY AND FITNESS FOR A PARTICULAR PURPOSE (AND THEIR EQUIVALENTS UNDER THE LAWS OF ANY JURISDICTION).

Diodes Incorporated and its subsidiaries reserve the right to make modifications, enhancements, improvements, corrections or other changes without further notice to this document and any product described herein. Diodes Incorporated does not assume any liability arising out of the application or use of this document or any product described herein; neither does Diodes Incorporated convey any license under its patent or trademark rights, nor the rights of others. Any Customer or user of this document or products described herein in such applications shall assume all risks of such use and will agree to hold Diodes Incorporated and all the companies whose products are represented on Diodes Incorporated website, harmless against all damages.

Diodes Incorporated does not warrant or accept any liability whatsoever in respect of any products purchased through unauthorized sales channel.

Should Customers purchase or use Diodes Incorporated products for any unintended or unauthorized application, Customers shall indemnify and hold Diodes Incorporated and its representatives harmless against all claims, damages, expenses, and attorney fees arising out of, directly or indirectly, any claim of personal injury or death associated with such unintended or unauthorized application.

Products described herein may be covered by one or more United States, international or foreign patents pending. Product names and markings noted herein may also be covered by one or more United States, international or foreign trademarks.

LIFE SUPPORT

Diodes Incorporated products are specifically not authorized for use as critical components in life support devices or systems without the express written approval of the Chief Executive Officer of Diodes Incorporated. As used herein:

A. Life support devices or systems are devices or systems which:

1. are intended to implant into the body, or
2. support or sustain life and whose failure to perform when properly used in accordance with instructions for use provided in the labeling can be reasonably expected to result in significant injury to the user.

B. A critical component is any component in a life support device or system whose failure to perform can be reasonably expected to cause the failure of the life support device or to affect its safety or effectiveness.

Customers represent that they have all necessary expertise in the safety and regulatory ramifications of their life support devices or systems, and acknowledge and agree that they are solely responsible for all legal, regulatory and safety-related requirements concerning their products and any use of Diodes Incorporated products in such safety-critical, life support devices or systems, notwithstanding any devices- or systems-related information or support that may be provided by Diodes Incorporated. Further, Customers must fully indemnify Diodes Incorporated and its representatives against any damages arising out of the use of Diodes Incorporated products in such safety-critical, life support devices or systems.

Copyright © 2011, Diodes Incorporated

www.diodes.com

Looking for pricing, stock, or lifecycle information?

Click below to explore more details on WIN SOURCE:

 [View ZXCT1012ET5TA on WIN SOURCE](#)

 [Diodes Incorporated](#) Information

Optimize Your Supply Chain with WIN SOURCE Solutions

-  Global Sourcing Solution
-  Obsolete Management
-  Cost Control Management
-  Shortage Management
-  Alternative Solution
-  Excess Inventory Management