



**THE DATASHEET OF  
ZXCT1008FTA**



## Description

The ZXCT1008 is a high side current sense monitor. Using this device eliminates the need to disrupt the ground plane when sensing a load current.

It takes a high side voltage developed across a current shunt resistor and translates it into a proportional output current. A user defined output resistor scales the output current into a ground-referenced voltage.

The wide input voltage range of 20V down to as low as 2.5V make it suitable for a range of applications. The ability to withstand high voltage transients and reverse polarity connection makes this part very suitable for automotive and other transient rich environment.

## Features

- Low Cost, Accurate High-Side Current Sensing
- -40 to +125°C Temperature Range
- Up to 500mV Sense Voltage
- 2.5V to 20V Supply Range
- 4µA Quiescent Current
- 1% Typical Accuracy
- SOT23
- **Totally Lead-Free & Fully RoHS Compliant (Notes 1 & 2)**
- **Halogen and Antimony Free. "Green" Device (Note 3)**
- **An Automotive-Compliant Part is Available Under Separate Data Sheet ([ZXCT1008Q](#))**

## Applications

- Automotive Current Measurement
- DC Motor and Solenoid Control
- Over Current Monitor
- Power Management

## Pin Assignments

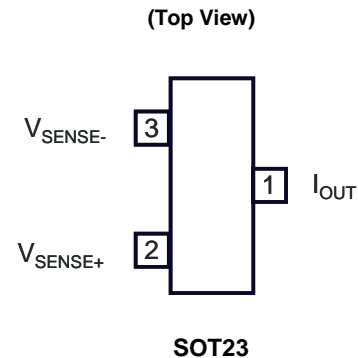

## Application Circuit

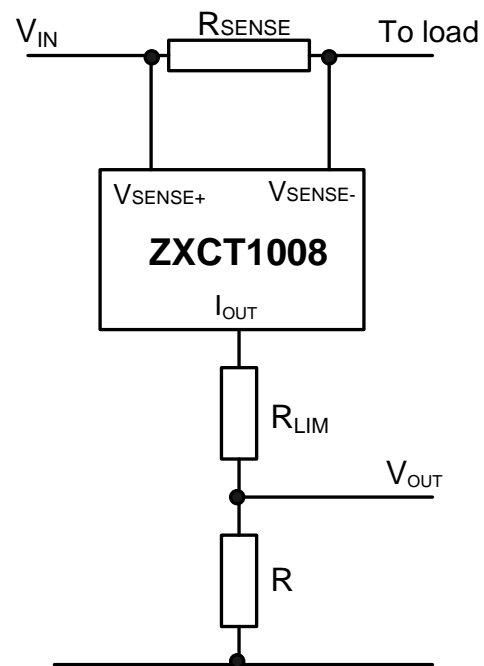

Notes:

1. No purposely added lead. Fully EU Directive 2002/95/EC (RoHS) & 2011/65/EU (RoHS 2) compliant.
2. See [http://www.diodes.com/quality/lead\\_free.html](http://www.diodes.com/quality/lead_free.html) for more information about Diodes Incorporated's definitions of Halogen- and Antimony-free, "Green" and lead-free.
3. Halogen- and Antimony-free "Green" products are defined as those which contain <900ppm bromine, <900ppm chlorine (<1500ppm total Br + Cl) and <1000ppm antimony compounds.

## Pin Descriptions

Pin Name	Pin Function
V <sub>SENSE+</sub>	Connection to Supply Voltage
V <sub>SENSE-</sub>	Connection to Load
I <sub>OUT</sub>	Output Current, Proportional to Measured Current

## Absolute Maximum Ratings (@T<sub>A</sub> = +25°C, unless otherwise specified.)

Description	Rating	Unit
Voltage on Any Pin (relative to I <sub>OUT</sub> )	-0.6 to 20	V
Continuous Output Current, I <sub>OUT</sub>	25	mA
Continuous Sense Voltage, V <sub>SENSE</sub> (Note 4)	-0.5 to 5	V
Operating Temperature, T <sub>A</sub>	-40 to +85	°C
Storage Temperature	-55 to +125	°C
Package Power Dissipation @ T <sub>A</sub> = +25°C (Derate to Zero @ +125°C)	450	mW

Operation above the absolute maximum rating may cause device failure. Operation at the absolute maximum ratings for extended periods may reduce device reliability.

## Electrical Characteristics (@T<sub>A</sub> = +25°C, V<sub>IN</sub> = 5V, R<sub>OUT</sub> = 100Ω, unless otherwise specified.)

Symbol	Parameter	Conditions	Min	Typ	Max	Unit
V <sub>IN</sub>	V <sub>CC</sub> Range	—	2.5	—	20	V
I <sub>OUT</sub>	Output Current (Note 5)	V <sub>SENSE</sub> = 0V V <sub>SENSE</sub> = 10mV V <sub>SENSE</sub> = 100mV V <sub>SENSE</sub> = 200mV V <sub>SENSE</sub> = 500mV	1 90 0.975 1.95 4.8	4 104 1.0 2.0 5.0	15 120 1.025 2.05 5.2	μA μA mA mA mA
V <sub>SENSE</sub>	Sense Voltage (Note 4)	—	0	—	500	mV
I <sub>SENSE-</sub>	V <sub>SENSE-</sub> Input Current	—	—	—	100	nA
A <sub>CC</sub>	Accuracy	R <sub>SENSE</sub> = 0.1Ω, V <sub>SENSE</sub> = 200mV	-2.5	—	2.5	%
G <sub>M</sub>	Transconductance, I <sub>OUT</sub> /V <sub>SENSE</sub>	—	—	10,000	—	μA/V
BW	Bandwidth	V <sub>SENSE(DC)</sub> = 10mV, R <sub>F</sub> P <sub>IN</sub> = -40dBm (Note 6)	—	300	—	kHz
		V <sub>SENSE(DC)</sub> = 100mV, R <sub>F</sub> P <sub>IN</sub> = -20dBm (Note 6)	—	2	—	MHz

Notes: 4. V<sub>SENSE</sub> is defined as the differential voltage between V<sub>SENSE+</sub> and V<sub>SENSE-</sub>.

$$\begin{aligned}
 V_{SENSE} &= V_{SENSE+} - V_{SENSE-} \\
 &= V_{IN} - V_{LOAD} \\
 &= I_{LOAD} \times R_{SENSE}
 \end{aligned}$$

5. Includes input offset voltage contribution.

6. -20dBm=63mV<sub>pp</sub> into 50Ω.

**Typical Characteristics**

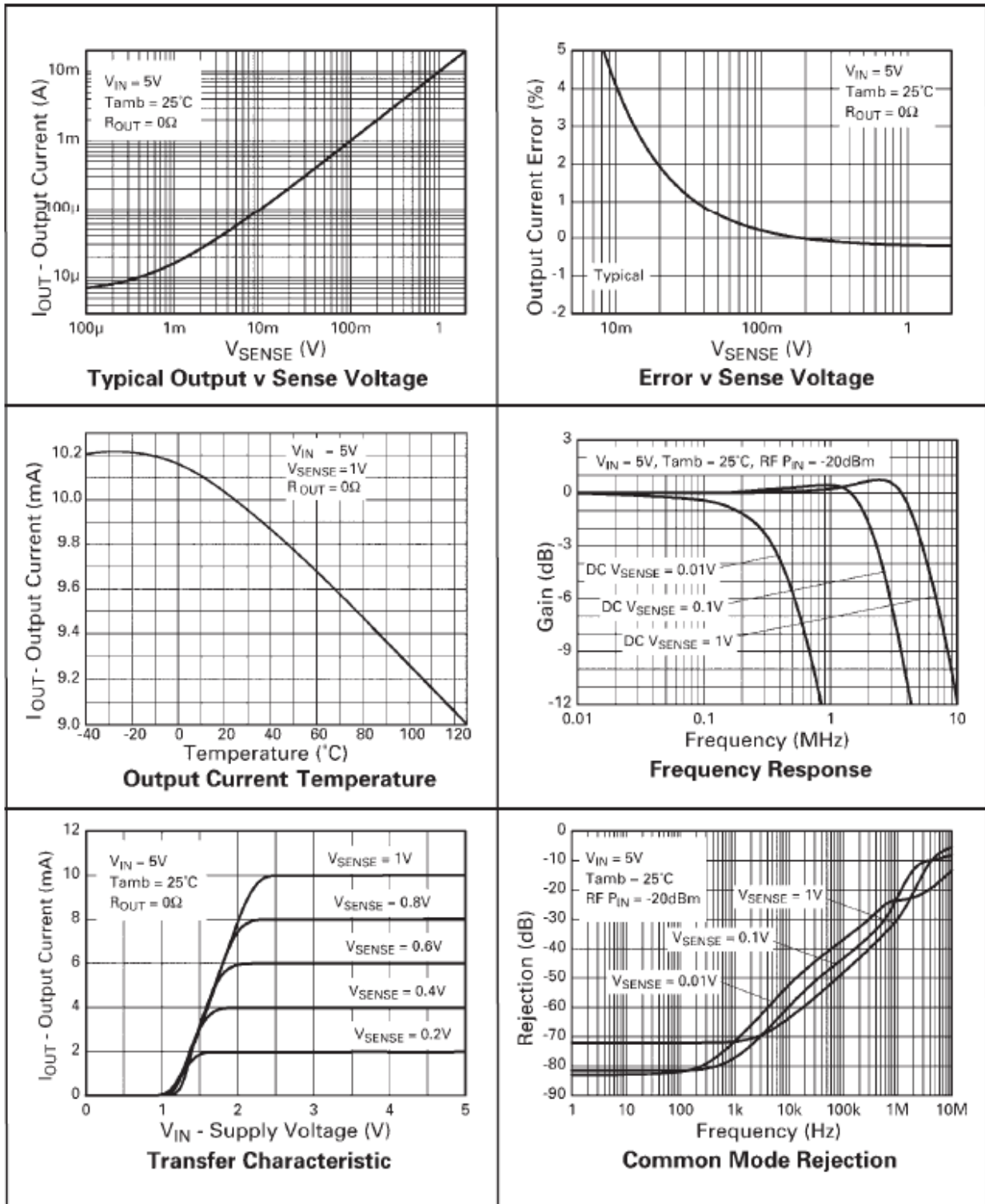

**Typical Characteristics** (Continued)

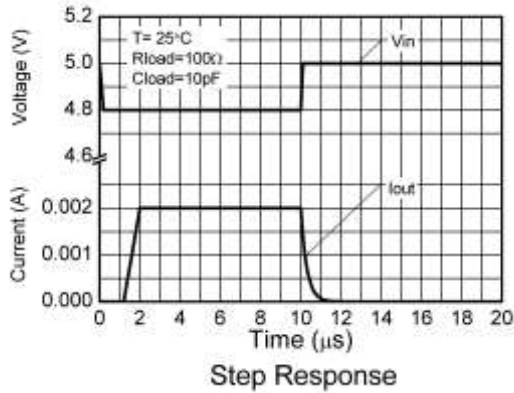

**Power Dissipation**

The maximum allowable power dissipation of the device for normal operation ( $P_{MAX}$ ), is a function of the package junction to ambient thermal resistance ( $\theta_{JA}$ ), maximum junction temperature ( $T_{JMAX}$ ), and ambient temperature ( $T_{AMB}$ ), according to the expression:

$$P_{MAX} = (T_{JMAX} - T_{AMB}) / \theta_{JA}$$

The device power dissipation,  $P_D$  is given by the expression:

$$P_D = I_{OUT} \times (V_{IN} - V_{OUT}) W$$

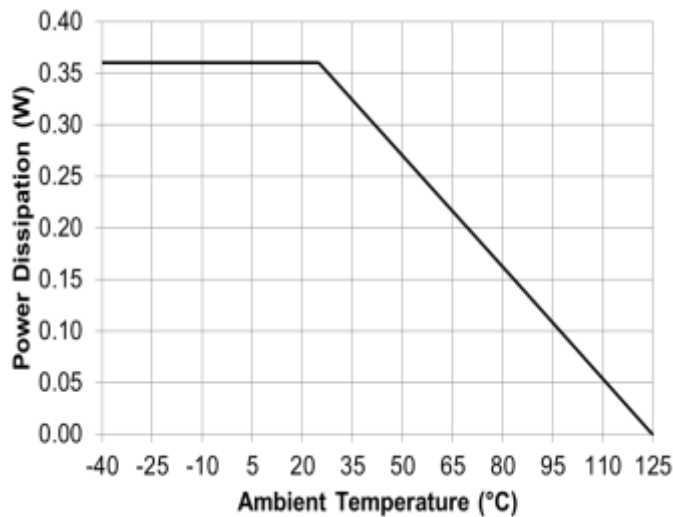

**Application Information**

The following text describes how to scale a load current to an output voltage.

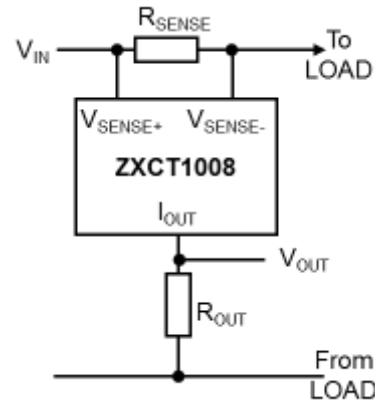

Figure 1. Generic ZXCT1008 Configuration

$$V_{SENSE} = V_{IN} - V_{LOAD} = I_{LOAD} \times R_{SENSE} \quad (1)$$

$$V_{OUT} = I_{OUT} \times R_{OUT} = 0.01 \times V_{SENSE} \times R_{OUT} \quad (2)$$

E.G.

A 1A current is to be represented by a 100mV output voltage:

- 1) Choose a value of  $R_{SENSE}$  so that at full load:

$$50mV > V_{SENSE} > 500mV.$$

For example, choose  $V_{SENSE} = 100mV$  at 1.0A.

$$\text{From (1) } R_{SENSE} = V_{SENSE} / I_{LOAD} = 0.1 / 1.0 = 0.1\Omega.$$

- 2) Choose  $R_{OUT}$  to give  $V_{OUT} = 100mV$  @  $V_{SENSE} = 100mV$

Rearranging (2) for  $R_{OUT}$  gives:

$$R_{OUT} = V_{OUT} / (V_{SENSE} \times 0.01) \\ = 0.1 / (0.1 \times 0.01) = 100\Omega$$

## Application Information (Continued)

### ZXCT1008 Application with High Transients

Where  $R_{LOAD}$  represents any load including DC motors, a charging battery or further circuitry that requires monitoring,  $R_{SENSE}$  can be selected on specific requirements of accuracy, size and power rating.

An additional resistor,  $R_{LIM}$  can be added in series with  $R_{OUT}$  (as below), to limit the current from  $I_{OUT}$ . Any circuit connected to  $V_{OUT}$  will be protected from input voltage transients. This can be of particular use in automotive applications where load dump and other common transients need to be considered. The Zener Z1 provides additional protection for local dump, reverse battery and high voltage transient incidents.

Assuming the worst case condition of  $V_{OUT} = 0V$ ; providing a low impedance to a transient, the minimum value of  $R_{LIM}$  is given by:

$$R_{LIM(min)} = (V_{PK} - V_{MAX})/I_{PK}$$

where

- $V_{PK}$  = Peak transient voltage to be withstood
- $V_{MAX}$  = Maximum working voltage = 20V
- $I_{PK}$  = Peak output current = 40mA

The maximum value of  $R_{LIM}$  is set by  $V_{IN(MIN)}$ ,  $V_{OUT(MAX)}$  and the dropout voltage (see transfer characteristic on page 3) of the ZXCT1008:

### PCB Trace Shunt Resistor for Low Cost Solution

The figure below shows output characteristics of the device when using a PCB resistive trace for a low cost solution in replacement for a conventional shunt resistor. The graph shows the linear rise in voltage across the resistor due to the PTC of the material and demonstrates how this rise in resistance value over temperature compensates for the NTC of the device.

The figure opposite shows a PCB layout suggestion. The resistor section is 25mm x 0.25mm giving approximately 150mΩ using 1oz copper. The data for the normalized graph was obtained using a 1A load current and a 100Ω output resistor. An electronic version of the PCB layout is available through Diodes applications group.

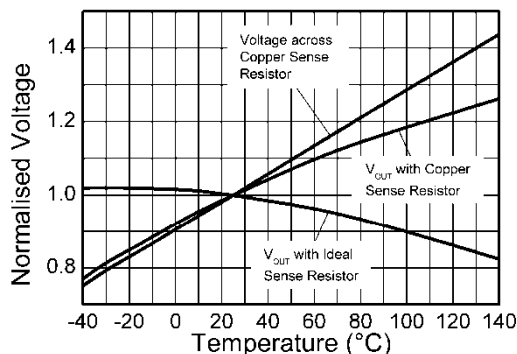

Effect of Sense Resistor Material on Temperature Performance

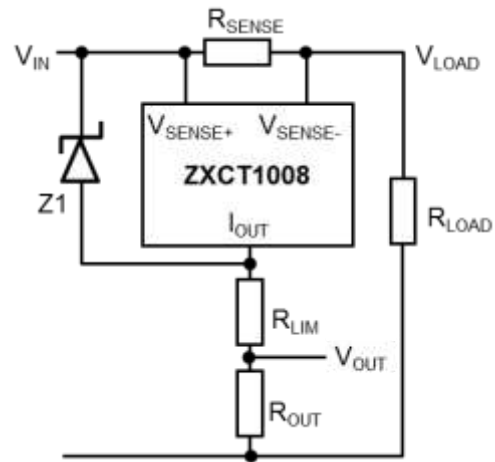
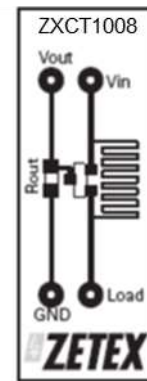

Figure 2. ZXCT1008 with Additional Current Limiting Resistor  $R_{LIM}$  and Zener Z1

$$R_{LIM(MAX)} = \frac{R_{OUT} \times (V_{IN(MIN)} - (V_{DP} + V_{OUT(MAX)}))}{V_{OUT(MAX)}}$$

Where

- $V_{IN(MIN)}$  = Minimum Supply Operating Voltage
- $V_{DP}$  = Dropout Voltage
- $V_{OUT(MAX)}$  = Maximum Operating Output Voltage



Layout shows area of shunt resistor compared to SOT23 package. Not actual size.

## Ordering Information

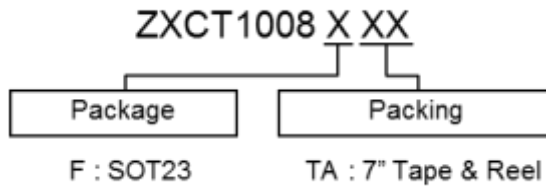

Device	Packaging (Note 7)	Package Code	Identification Code	Packing: 7" Tape and Reel		
				Quantity	Tape Width	Part Number Suffix
ZXCT1008FTA	SOT23	F	108	3,000 Units	8mm	TA

Note: 7. Pad layout as shown on Diodes' suggested pad layout per <http://www.diodes.com/package-outlines.html>.

## Marking Information

(1) Package Type: SOT23

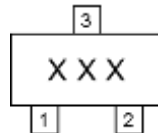

XXX : Identification Code: 108

## Package Outline Dimensions

Please see <http://www.diodes.com/package-outlines.html> for the latest version.

SOT23

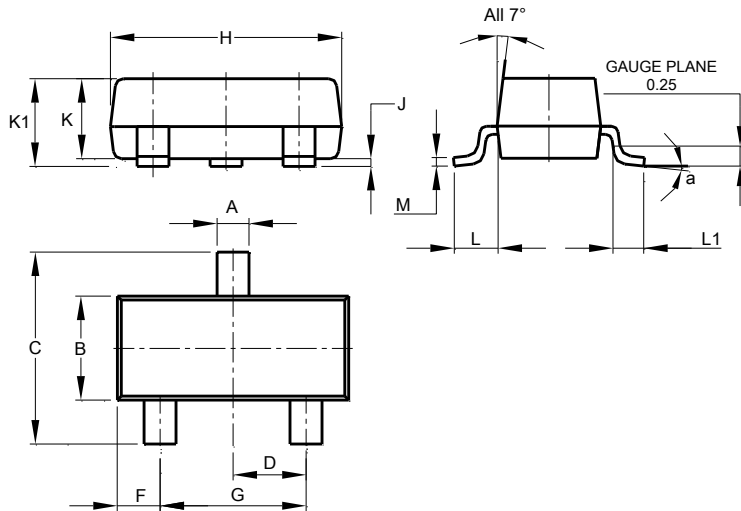

SOT23			
Dim	Min	Max	Typ
A	0.37	0.51	0.40
B	1.20	1.40	1.30
C	2.30	2.50	2.40
D	0.89	1.03	0.915
F	0.45	0.60	0.535
G	1.78	2.05	1.83
H	2.80	3.00	2.90
J	0.013	0.10	0.05
K	0.890	1.00	0.975
K1	0.903	1.10	1.025
L	0.45	0.61	0.55
L1	0.25	0.55	0.40
M	0.085	0.150	0.110
a	0°	8°	--
All Dimensions in mm			

## Suggested Pad Layout

Please see <http://www.diodes.com/package-outlines.html> for the latest version.

SOT23

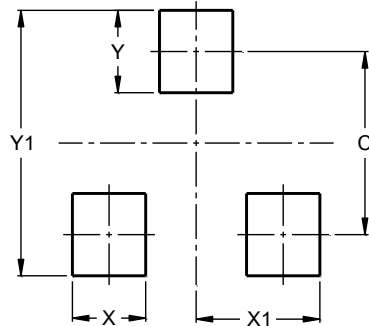

Dimensions	Value (in mm)
C	2.0
X	0.8
X1	1.35
Y	0.9
Y1	2.9

**IMPORTANT NOTICE**

DIODES INCORPORATED MAKES NO WARRANTY OF ANY KIND, EXPRESS OR IMPLIED, WITH REGARDS TO THIS DOCUMENT, INCLUDING, BUT NOT LIMITED TO, THE IMPLIED WARRANTIES OF MERCHANTABILITY AND FITNESS FOR A PARTICULAR PURPOSE (AND THEIR EQUIVALENTS UNDER THE LAWS OF ANY JURISDICTION).

Diodes Incorporated and its subsidiaries reserve the right to make modifications, enhancements, improvements, corrections or other changes without further notice to this document and any product described herein. Diodes Incorporated does not assume any liability arising out of the application or use of this document or any product described herein; neither does Diodes Incorporated convey any license under its patent or trademark rights, nor the rights of others. Any Customer or user of this document or products described herein in such applications shall assume all risks of such use and will agree to hold Diodes Incorporated and all the companies whose products are represented on Diodes Incorporated website, harmless against all damages.

Diodes Incorporated does not warrant or accept any liability whatsoever in respect of any products purchased through unauthorized sales channel. Should Customers purchase or use Diodes Incorporated products for any unintended or unauthorized application, Customers shall indemnify and hold Diodes Incorporated and its representatives harmless against all claims, damages, expenses, and attorney fees arising out of, directly or indirectly, any claim of personal injury or death associated with such unintended or unauthorized application.

Products described herein may be covered by one or more United States, international or foreign patents pending. Product names and markings noted herein may also be covered by one or more United States, international or foreign trademarks.

This document is written in English but may be translated into multiple languages for reference. Only the English version of this document is the final and determinative format released by Diodes Incorporated.

**LIFE SUPPORT**

Diodes Incorporated products are specifically not authorized for use as critical components in life support devices or systems without the express written approval of the Chief Executive Officer of Diodes Incorporated. As used herein:

A. Life support devices or systems are devices or systems which:

1. are intended to implant into the body, or
2. support or sustain life and whose failure to perform when properly used in accordance with instructions for use provided in the labeling can be reasonably expected to result in significant injury to the user.

B. A critical component is any component in a life support device or system whose failure to perform can be reasonably expected to cause the failure of the life support device or to affect its safety or effectiveness.

Customers represent that they have all necessary expertise in the safety and regulatory ramifications of their life support devices or systems, and acknowledge and agree that they are solely responsible for all legal, regulatory and safety-related requirements concerning their products and any use of Diodes Incorporated products in such safety-critical, life support devices or systems, notwithstanding any devices- or systems-related information or support that may be provided by Diodes Incorporated. Further, Customers must fully indemnify Diodes Incorporated and its representatives against any damages arising out of the use of Diodes Incorporated products in such safety-critical, life support devices or systems.

Copyright © 2017, Diodes Incorporated

[www.diodes.com](http://www.diodes.com)

## Looking for pricing, stock, or lifecycle information?

Click below to explore more details on WIN SOURCE:

 [View ZXCT1008FTA on WIN SOURCE](#)

 [Diodes Incorporated](#) Information

## Optimize Your Supply Chain with WIN SOURCE Solutions

-  Global Sourcing Solution
-  Obsolete Management
-  Cost Control Management
-  Shortage Management
-  Alternative Solution
-  Excess Inventory Management