



**THE DATASHEET OF
ZXBM2004JA16TC**



Description

The ZXBM2004 is a 2-phase, Brushless Direct Current (BLDC) motor control pre-driver with variable PWM speed control suitable for fan and blower motors.

For system flexibility, motor speed can be controlled by changing SPD pin voltage which can be either from Thermistor network, external voltage or PWM signal.

To help protect the motor coil, the ZXBM2004 provides Rotor Lock Protection which shuts down the output drive if rotor lock is detected. The device automatically re-starts when the rotor lock is removed.

A Tachometer output is provided by open-drain Frequency Generator (FG) Pin which allows external interface to monitor motor rotation or speed. The FG output is the magnetic change frequency.

The ZXBM2004 is available in small space saving low profile U-QFN3030-16 and QSOP-16 packages.

Features

- Supports two-phase BLDC motor control
- Operating voltage: 4.7V to 18V
 - Can be extended with external regulator
- PWM speed control via external Thermistor, DC voltage or PWM signals
- Reference voltage output
- Built-in Hall amplifier allows direct connection of Hall element
- Rotor Lock Protection (Lock detection, output shutdown and automatic re-start)
- Rotor lock detect (RD) output
- Minimum speed setting
- Frequency generator (FG) output for speed measurements
- Low noise
- Space saving low profile U-QFN3030-16 and QSOP-16 packages
- “Green” Molding Compound

Pin Assignments

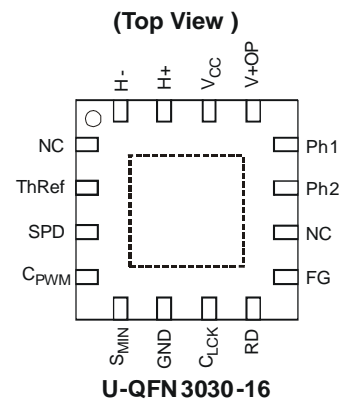
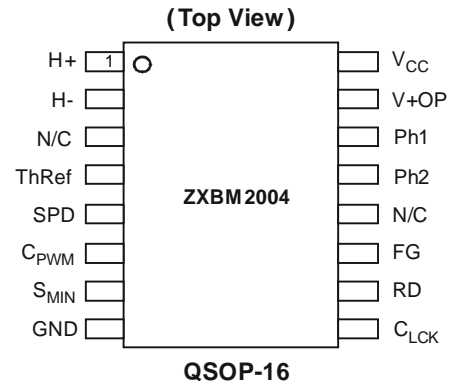

Applications

- Desktop PC and Servers fans and blowers
- Instrumentation fans
- Central heating blowers
- Automotive instrument cooling and climate control
- Extractor fans
- General motors and pumps

Typical Application Circuit

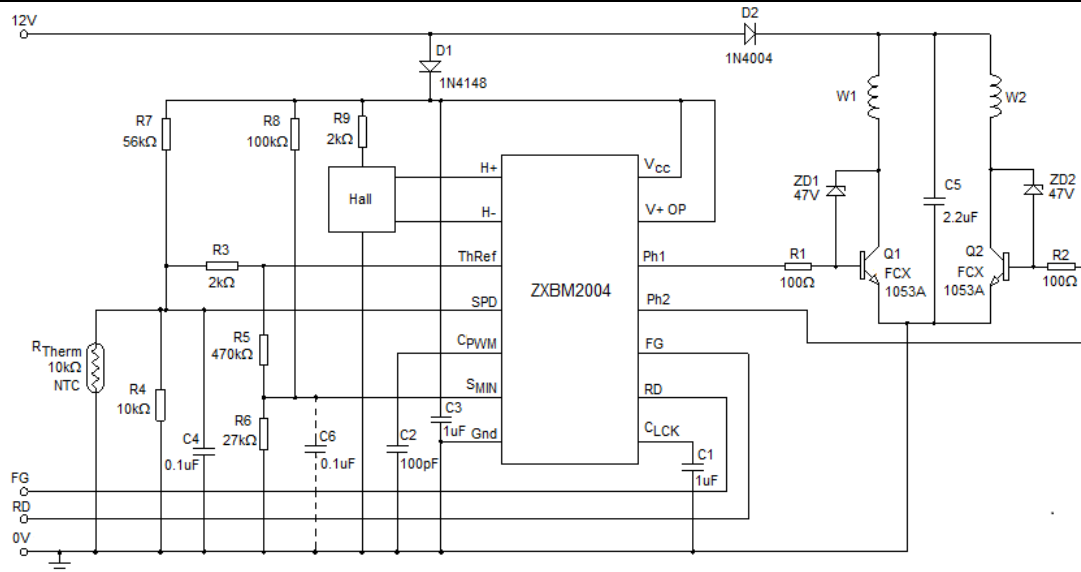

Pin Descriptions

Pin Name	Description
H+	Hall input to non-inverting input of internal operational amplifier
H-	Hall input to inverting input of internal operational amplifier
ThRef	Reference output voltage
SPD	Speed control pin; The control signal voltage should be between 3V to 1V for 0% to 100% (full speed) speed control
C _{PWM}	PWM frequency setting pin: Connect a capacitor from this pin to ground (0V) to set PWM frequency. Capacitor of 0.1nF will give PWM frequency of 24kHz typical.
S _{MIN}	Minimum speed setting pin: Voltage between 3V to 1V on this pin sets the minimum speed between 0% to full speed. Lowest minimum speed achieved depends on the motor coil design.
GND	Supply return ground pin
C _{LCK}	Rotor lock detect and auto re-start timing pin: Connect a capacitor from this pin to ground to set the lock detect and restart timing.
RD	Rotor lock detect pin: Open collector output to indicate rotor lock detection Connect a pull-up resistor from the pin to the pull-up supply rail
FG	Frequency Generator output to provide a tachometer signal
Ph1	Phase-1 low-side external power switch drive output pin: Darlington emitter follower output with active pull down to give source/sink current of 80mA/16mA
Ph2	Phase-2 low-side external power switch drive output pin: Darlington emitter follower output with active pull down to give source/sink current of 80mA/16mA
V+OP	Phase output supply voltage pin: The pin allows to optimize the supply to output drive depending on whether external power switch is Bipolar switch or MOSFET
V _{CC}	Power supply pin

Functional Block Diagram (Note 1)

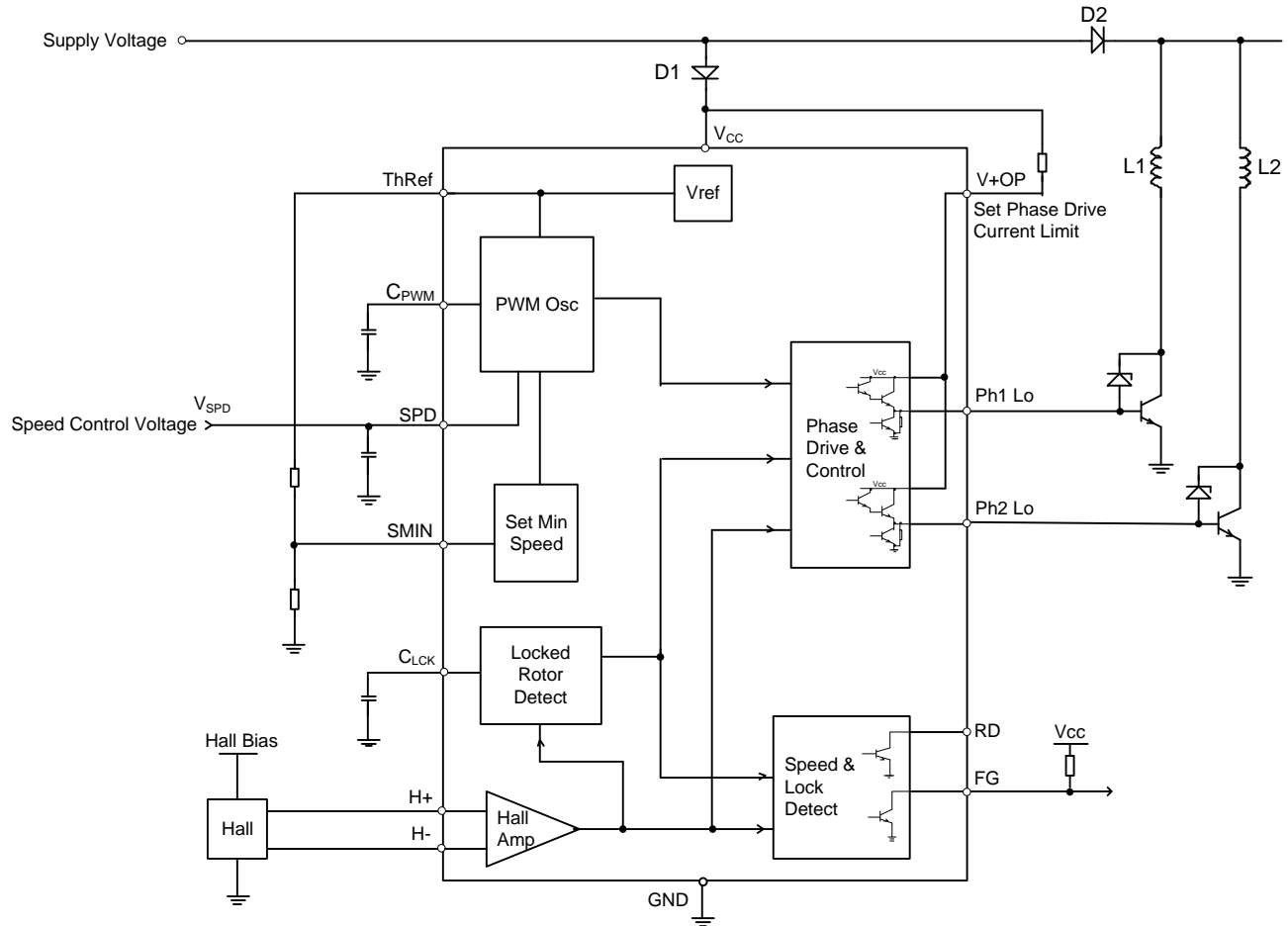

Notes: 1. The ZXBM2004 has an open-collector FG and RD. Typically a pull-up resistor of 10k Ω is recommended from FG or RD pin to the supply voltage.

Absolute Maximum Ratings ($T_A = 25^\circ\text{C}$, unless otherwise noted, Note 2)

Symbol	Characteristics	Values	Unit	
V_{CCMAX}	Supply voltage	-0.6 to +20	V	
I_{CCMAX}	IC input current	100	mA	
P_{DMAX}	Power Dissipation (Note 4)	QSOP-16	500	mW
		U-QFN3030-16 (Note 3)	1500	
T_A	Operating ambient temperature	-40 to +110	$^\circ\text{C}$	
T_{STG}	Storage Temperature Range	-55 to +150	$^\circ\text{C}$	

- Note:
- Stresses greater than the 'Absolute Maximum Ratings' specified above, may cause permanent damage to the device. These are stress ratings only; functional operation of the device at these or any other conditions exceeding those indicated in this specification is not implied. Device reliability may be affected by exposure to absolute maximum rating conditions for extended periods of time.
 - U-QFN3030-16 dissipation is based on a two-layer 2oz. copper 2"x 2" FR4 substrate PCB with thermal vias to the bottom layer.

Recommended Operating Conditions ($T_A = 25^\circ\text{C}$)

Symbol	Parameter	Conditions	Min	Max	Unit
V_{CC}	Supply Voltage	Operating	4.7	18.0	V
T_A	Operating Temperature Range	Operating	-40	+110	$^\circ\text{C}$

Electrical Characteristics ($T_A = 25^\circ\text{C}$, $V_{CC} = 12\text{V}$)

Symbol	Characteristics	Conditions	Min	Typ.	Max	Unit
I_{CC}	Supply Current	No Load (Note 4)	-	5.5	7.5	mA
V_{IN}	Hall amplifier input voltage	Diff peak to peak	40			mV
V_{CM}	Hall amplifier common mode voltage		0.5		$V_{CC} - 1.5$	V
V_{OFS}	Hall amplifier input offset voltage			± 7		mV
I_{BS}	Hall amplifier bias current			400	700	nA
V_{OH}	Ph1 and Ph2 output high voltage	$I_{OH} = 80\text{mA}$	$V_{CC} - 2.2$	$V_{CC} - 1.8$		V
V_{OLA}	Ph1 and Ph2 output low voltage	$I_{OH} = 16\text{mA}$ (Note 5)		0.4	0.6	V
V_{OLB}	Ph1 and Ph2 output low voltage	$I_{OH} = 50\mu\text{A}$ (Note 6)		0.4	0.6	V
I_{OH}	Ph1 and Ph2 output source current				80	mA
I_{OL}	Ph1 and Ph2 output sink current				16	mA
I_{PWMC}	C_{PWM} charge current		4.5		7.85	μA
I_{PWMD}	C_{PWM} discharge current		38		65	μA
V_{THH}	C_{PWM} high threshold voltage			3		V
V_{THL}	C_{PWM} low threshold voltage			1		V
F_{PWM}	PWM frequency	$C_{PWM} = 0.1\text{nF}$		24		kHz

- Notes:
- Measure with pins H+, H-, CLCK and C_{PWM} and all other signal pins open circuit
 - Measured when opposing Phase Output is Low
 - Measured when opposing Phase Output is High

Electrical Characteristics (cont.) ($T_A = 25^\circ\text{C}$, $V_{CC} = 12\text{V}$)

Symbol	Characteristics	Conditions	Min	Typ.	Max	Unit
V_{ThRef}	ThRef reference output voltage	$I_{OThRef} = 100\mu\text{A}$	2.88	2.96	3.10	V
I_{OThRef}	ThRef output current				1	mA
I_{SMIN}	S_{MIN} input current	$V_{IN} = 2\text{V}$, SPD=open		-0.25	-0.3	μA
V_{SPDL}	SPD voltage minimum	100% PWM drive		1		V
V_{SPDH}	SPD voltage maximum	0% PWM drive		3		V
I_{SPD}	SPD voltage maximum	$V_{IN} = 2\text{V}$		0.8	2	μA
I_{LCKC}	C_{LCK} charge current		2.8	3.8		μA
I_{LCKD}	C_{LCK} discharge current			4.6	0.54	μA
$V_{CLCKTHH}$	C_{LCK} high threshold voltage			3		V
$V_{CLCKTHL}$	C_{LCK} low threshold voltage			1		V
	Lock condition On:Off ratio			1:12		
I_{FGOL}	FG Low level output current				5	mA
V_{FGOL}	FG Low level output voltage	$I_{FGOL} = 5\text{mA}$			0.5	V
I_{RDOL}	RD Low level output current				5	mA
V_{RDOL}	RD Low level output voltage	$I_{RDOL} = 5\text{mA}$			0.5	V
t_{CD}	Commutation delay			7.5		μs

Functional Descriptions

H+ and H- Hall Inputs

The rotor position is detected by a Hall sensor, with the output applied to the H+ and H-pins. This sensor can be either a 4 pin 'naked' Hall device or of the 3 pin buffered switching type. For a 4 pin device the differential Hall output signal is connected to the H+ and H-pins. For a buffered Hall sensor the Hall device output is attached to the H+ pin, with a pull-up attached if needed, whilst the H-pin has an external potential divider attached to hold the pin at half V_{CC} . When H+ is high in relation to H-, Ph2 is the active drive.

ThRef - Output Reference Voltage

This is a reference voltage of nominal 3V. It is designed for the ability to 'source' and therefore it will not 'sink' any current from a higher voltage. The current drawn from the pin by the minimum speed potential divider to pin S_{MIN} and any voltage setting network should not exceed 1mA in total at maximum temperature.

SPD - Speed Control Input

The voltage applied to the SPD pin provides control over motor speed by varying the Pulse Width Modulated (PWM) drive ratio at the Ph1 and Ph2 outputs. The control signal takes the form of a voltage input of range 3V to 1V, representing 0% to 100% drive respectively.

If variable speed control is not required this pin can be left with an external potential divider to set a fixed speed or tied to ground to provide full speed i.e. 100% PWM drive.

If required this pin can also be used as an enable pin. The application of a voltage >3.0V will force the PWM drive fully off, in effect disabling the drive.

S_{MIN} – Minimum Speed Setting

A voltage can be set on S_{MIN} pin via a potential divider between the ThRef and Gnd. This voltage is monitored by the SPD pin such that internally SPD voltage cannot rise above S_{MIN} voltage. As a higher voltage on the SPD pin represents a lower speed it therefore restricts the lower speed range of the fan. If this feature is not required the pin is left tied to ThRef so no minimum speed will be set.

If the fan is being controlled from an external voltage source onto the SPD pin then either this feature should not be used or if it is required then a resistor greater than 1k Ω should be placed in series with the SPD pin.

C_{PWM} – Output PWM Frequency Setting

This pin has an external capacitor attached to set the PWM frequency for the Phase drive outputs. A capacitor value of 0.1nF will provide a PWM frequency of typically 24kHz. The C_{PWM} timing period (T_{PWM}) is determined by the following equation:

$$T_{PWM} = \frac{(V_{THH} - V_{THL}) \times C}{I_{PWMC}} + \frac{(V_{THH} - V_{THL}) \times C}{I_{PWMD}}$$

Where: C = (C_{PWM} +15) in pF

V_{THH} and V_{THL} are the C_{PWM} pin threshold voltages

I_{PWMC} and I_{PWMD} are the charge and discharge currents in μ A.

T_{PWM} is in ms

As these threshold voltages are nominally set to $V_{THH} = 3V$ and $V_{THL} = 1V$ the equations can be simplified as follows:

$$T_{PWM} = \frac{2C}{I_{PWMC}} + \frac{2C}{I_{PWMD}}$$

Functional Description (cont.)

C_{LCK} - Locked Rotor Timing Capacitor

Should the fan stop rotating for any reason, i.e. an obstruction in the fan blade or a seized bearing, then the device will enter a Rotor Locked condition. In this condition after a predetermined time (T_{LOCK}) the RD pin will go high and the Phase outputs will be disabled. After a further delay (T_{OFF}) the controller will re-enable the Phase drive for a defined period (T_{ON}) in an attempt to re-start the fan. This cycle of (T_{OFF}) and (T_{ON}) will be repeated indefinitely or until the fan re-starts.

GND – Supply Return

This is the device supply ground return pin and will generally be the most negative supply pin to the fan.

RD - Rotor Lock Detect Output

This pin is the Locked Rotor status output as referred to in the C_{LCK} timing section above. It is high when the rotor is stopped and low when it is running.

This is an open collector drive giving an active pull down with the high level being provided by an external pull up resistor.

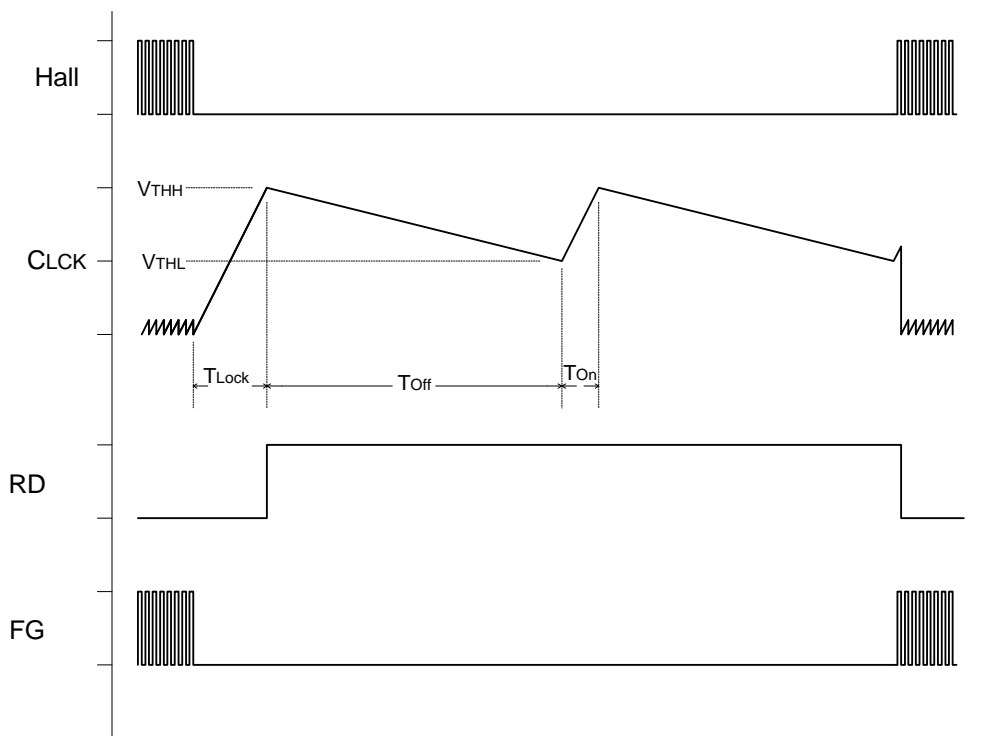

FR and RD Timing Diagram

Functional Descriptions (cont.)

FG -Frequency Generator (tachometer) Output

This is the Frequency Generator output and is a buffered signal from the Hall sensor.

This is an open collector drive giving an active pull down with the high level being provided by an external pull up resistor.

Ph1 and Ph2 Output Drives

This pair of outputs drives the external devices. These outputs provide both the commutation and PWM waveforms. The outputs are of the Darlington emitter follower type with an active pull-down to help faster switch off when using bipolar devices. When in the high state the outputs will provide up to 80mA of drive into the base or gates of external transistors as shown in the Typical Application circuit following.

When in the low state the active Phase drive is capable of sinking up to 16mA when driving low to aid turn off times during PWM operation. When the Phase is inactive the output is held low by an internal pull-down resistor.

V+OP Phase Outputs Supply Voltage

This pin is the supply to the Phase outputs and will be connected differently dependant upon external transistor type. For bipolar devices this pin will be connected by a resistor to the V_{CC} pin. The resistor is used to control the current into the transistor base so its value is chosen accordingly. For MOSFET devices the pin will connect directly to the V_{CC} pin.

 V_{CC} – Supply Voltage

This is the device internal circuitry supply voltage. For 5V to 12V fans this can be supplied directly from the Fan Motor supply. For fans likely to run in excess of the 18V maximum rating for the device this will be supplied from an external regulator such as a Zener diode.

Application Note

The ZXBM2004 is primarily controlled by a voltage on the SPD pin. A voltage of 1V represents a 100% PWM at the Phase Outputs and in turn represents full speed. 3V on the SPD pin conversely represents 0% PWM. The motor can therefore be controlled simply by applying a control voltage onto the SPD pin with the minimal use of external components.

This voltage control method easily lends itself to control by other signal types. For example if a Thermistor is applied to the SPD pin a varying voltage can be generated at the SPD pin as the resistance of the Thermistor varies with temperature.

A common form of control of fans is by a PWM signal derived from a central processor or controller. This signal can be converted into a voltage and that voltage adjusted as necessary to compensate for motor non linearity, inclusion of the Minimum speed feature etc.

Full applications details and further examples of how to control the ZXBM2004 are available in the Applications Notes AN41, AN42 and AN43.

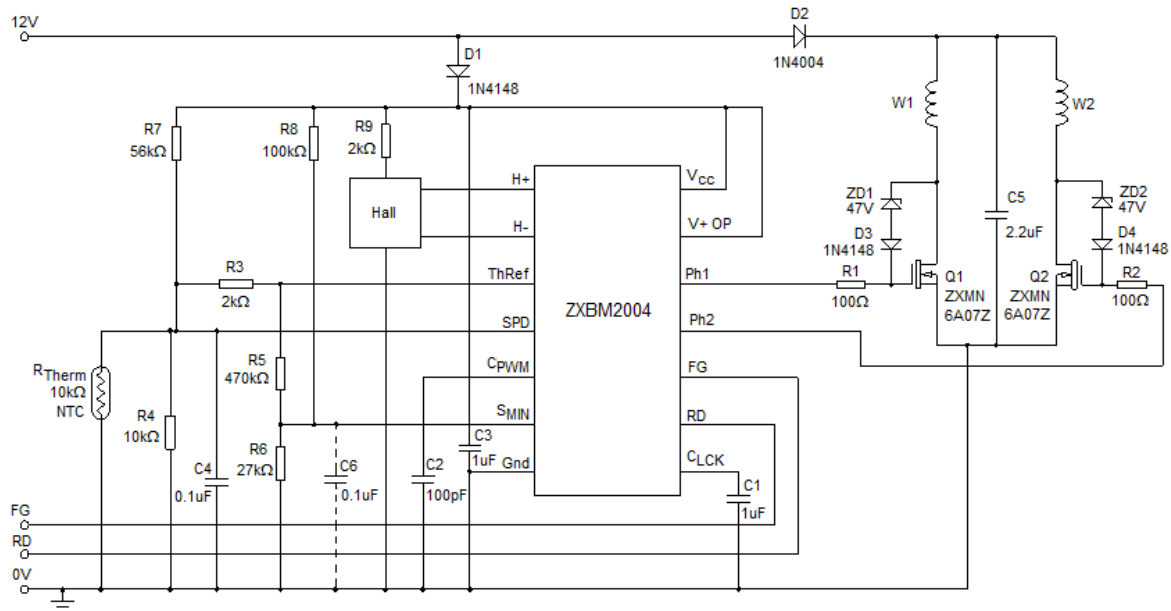

Fig 1. 12V Typical Circuit for Thermistor Controlled Speed

Application Note (cont.)

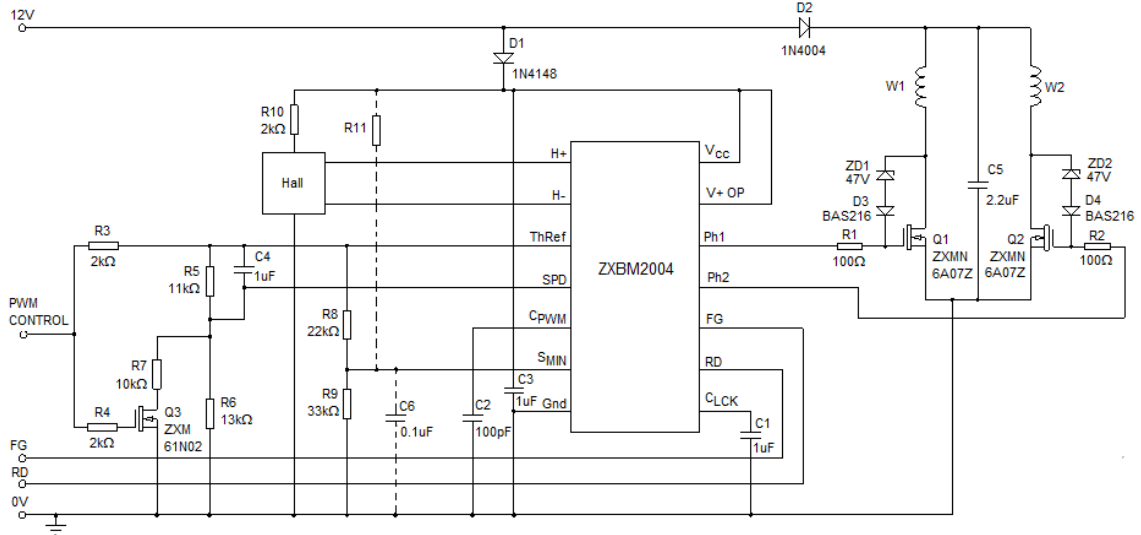

Fig. 2 Typical Circuit for External PWM Controlled Speed (Single MOSFET)

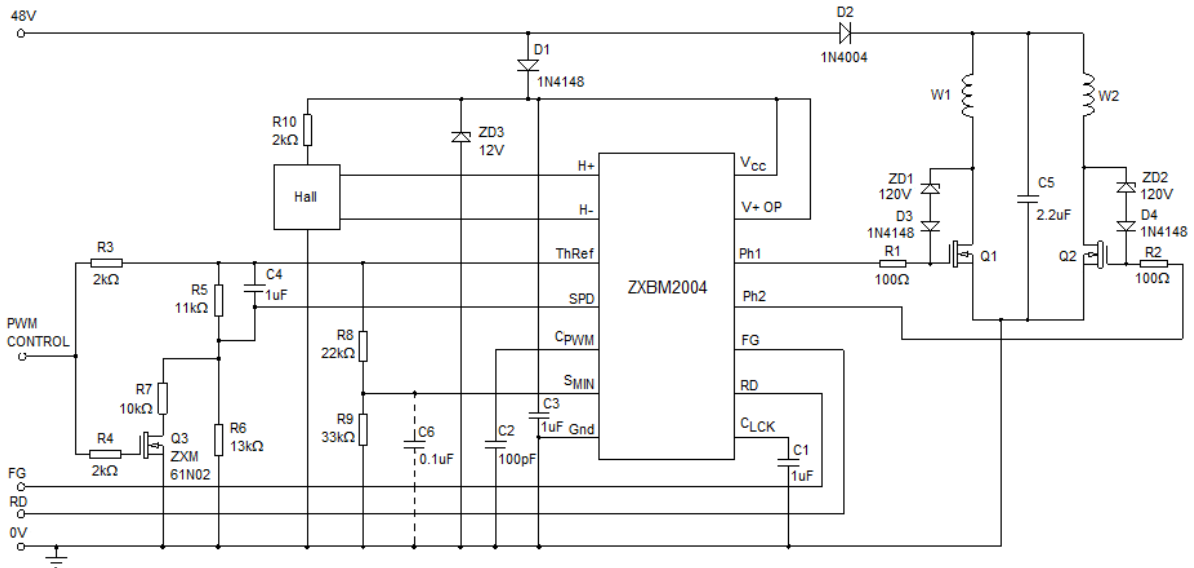

Fig. 3 Typical Circuit for 48V Input and External PWM Control

Application Note (cont.)

External Drive Transistors

Diodes offers a range of devices that are ideally suited to interface between the ZXBM2004 controller and the motor. The following tables show a selection of products. If your needs are not covered by this selection then please refer to the more comprehensive listings that can be found on the Diodes website: www.didoes.com

MOSFETS

Part Number	Type	BV _{DSS} (V)	I _D (A)	R _{DS(on)} @ V _{GS} = 10V (Ω)	Package
Power switch					
ZXMN10A09K	N	100	7.7	0.085	TO252-3L
ZXMN10A25K	N	100	6.4	0.125	TO252-3L
ZXMN10A25G	N	100	4.0	0.125	SOT223
ZXMN10A11G	N	100	2.4	0.35	SOT223
ZXMN10A08DN8	2 x N	100	2.1	0.25	SO8
ZXMN10B08E6	N	100	1.9	0.230	SOT23-6
ZXMN10A07Z	N	100	1.4	0.7	SOT89
ZXMN6A09K	N	60	11.2	0.04	TO252-3L
ZXMN6A25K	N	60	10.7	0.05	TO252-3L
DMN6068LK3	N	60	8.5	0.068	TO252-3L
ZXMN6A09G	N	60	7.5	0.04	SOT223
ZXMN6A25G	N	60	6.7	0.05	SOT223
ZXMN7A11K	N	60	6.1	0.120	TO252-3L
ZXMN6A09DN8	2 x N	60	5.6	0.04	SO8
DMN6068SE	N	60	5.6	0.068	SOT223
ZXMN6A08G	N	60	5.3	0.08	SOT223
ZXMN6A25DN8	2 x N	60	4.7	0.055	SO8
ZXMN6A11Z	N	60	3.6	0.120	SOT89
ZXMN6A07Z	N	60	2.2	0.250	SOT89
ZXMN6A07F	N	60	1.4	0.250	SOT23

Application Note (cont.)

Bipolar Transistors

Part Number	Type	V _{CEO} (V)	I _C (A)	V _{CE(sat)} @I _C /I _B (mV @ A/mA)	Package
Power switch					
FZT855	NPN	150	4	65 @ 0.5/50	SOT223
FMMT624	NPN	125	1	150 @ 0.5/50	SOT23
ZX5T853G	NPN	100	6	125 @ 2/100	SOT223
ZXTN19100CZ	NPN	100	5.25	65 @ 1/100	SOT89
ZXTN25100BFH	NPN	100	3	135 @ 0.5/10	SOT23
ZXTN25100DFH	NPN	100	2.5	170 @ 0.5/10	SOT23
FCX493	NPN	100	1	300 @ 0.5/50	SOT89
FCX1053A	NPN	75	3	200 @ 1/10	SOT89
ZXTN19060CG	NPN	60	7	155 @ 1/10	SOT223
ZX5T851G	NPN	60	6	135 @ 2/50	SOT223
DXT2010P5	NPN	60	5	70 @ 1/10	PowerDI5
FCX493A	NPN	60	1	500 @ 1/50	SOT89
FCX619	NPN	50	3	260 @ 2/50	SOT89
FMMT619	NPN	50	2	220 @ 2/50	SOT23
FCX619	NPN	50	3	260 @ 2/50	SOT89
Drive buffer and level shift					
FMMT493	NPN	100	1	300 @ 0.5/50	SOT23
FMMT493A	NPN	60	1	250 @ 0.5/50	SOT23
ZXTN2038F	NPN	60	1	250 @ 0.5/50	SOT23
DSS4160	NPN	60	1	140 @ 0.5/50	SOT563

Thermal Performance Characteristics

(1) Package Type: QSOP-16

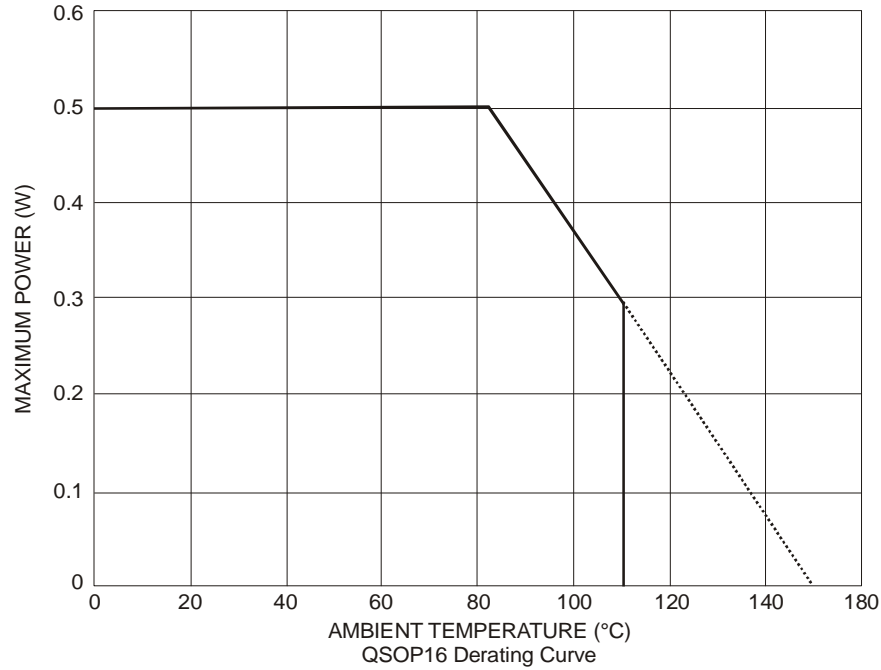

(2) Package Type: U-QFN3030-16 (Note 7)

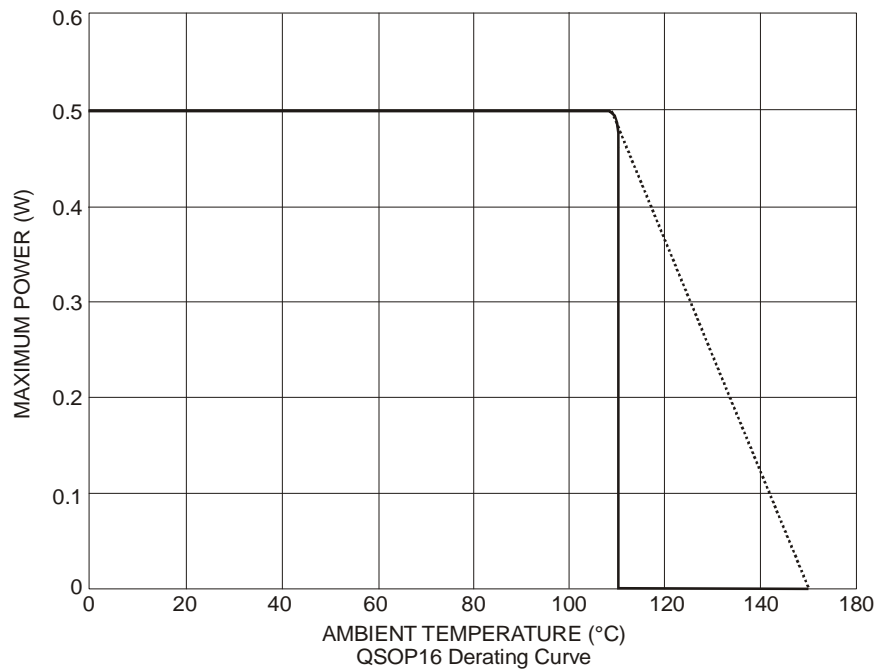

Note: 7. U-QFN3030-16 dissipation is based on a two-layer 2oz. copper 2"x2" FR4 substrate PCB with thermal vias to the bottom layer.

Ordering Information

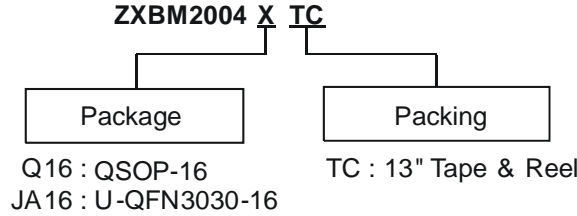

Device	Packaging (Note 8 & 9)	13" Tape and Reel	
		Quantity	Part Number Suffix
ZXBM2004Q16TC	QSOP-16	2500/Tape & Reel	TC
ZXBM2004JA16TC	U-QFN3030-16	3000/Tape & Reel	TC

Notes: 8. Pad layout as shown on Diodes Inc. suggested pad layout document AP02001, which can be found on our website at <http://www.diodes.com/datasheets/ap02001.pdf>
 9. EU Directive 2002/95/EC (RoHS) & 2011/65/EU (RoHS 2) compliant. No purposely added lead. Halogen and Antimony free. Please visit our website at http://www.diodes.com/products/lead_free.html

Marking Information

(1) Package type: QSOP-16

(Top View)

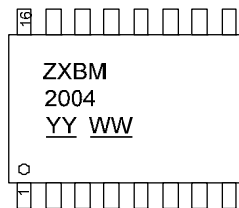

YY : Year 00~99
WW : Week : 01~52 week;
 52 represents 52 and 53 week

Part Number	Package	Identification Code
ZXBM2004Q16TC	QSOP-16	ZXBM 2004

(2) Package type: U-QFN3030-16

(Top View)

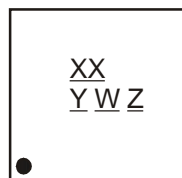

XX : Identification Code
Y : Year : 0 ~ 9
W : Week : A ~ Z : 1 ~ 26 week;
 a ~ z : 27 ~ 52 week: z represents
 52 and 53 week
Z : A ~ Z : Internal Code

Part Number	Package	Identification Code
ZXBM2004JA16TC	U-QFN3030-16	24

Package Outline Dimensions (All Dimensions in mm)

(1) Package type: QSOP-16

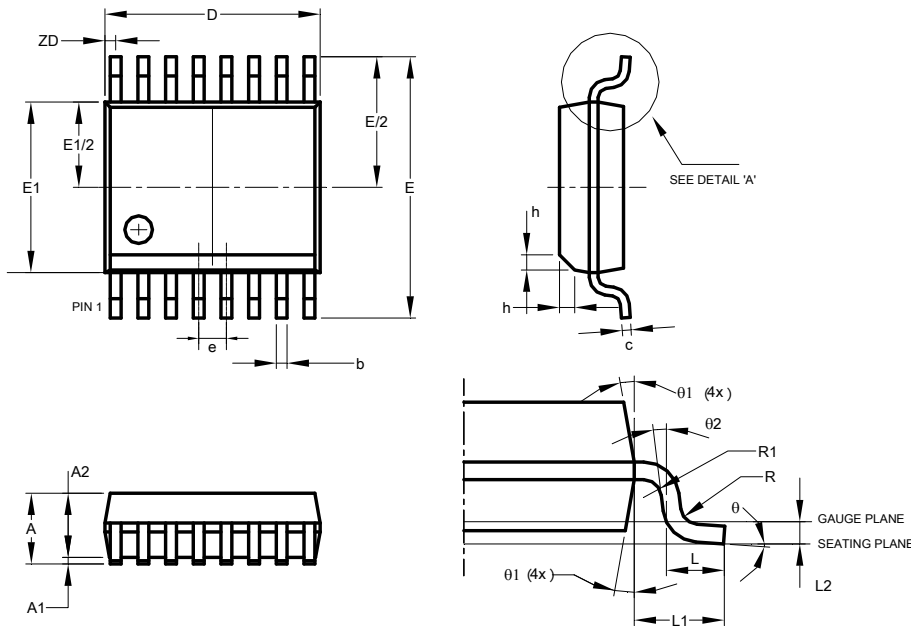

QSOP-16			
Dim	Min	Max	Typ
A	1.55	1.73	-
A1	0.10	0.25	-
A2	1.40	1.50	-
b	0.20	0.30	-
c	0.18	0.25	-
D	4.80	5.00	-
E	5.79	6.20	-
E1	3.81	3.99	-
e	0.635 BSC		
h	0.254	0.508	-
L	0.41	1.27	-
L1	1.03 REF		
L2	0.254 BSC		
R	0.0762	-	-
R1	0.0762	-	-
ZD	0.23 REF		
θ	0°	8°	-
θ1	5°	15°	-
θ2	0°	-	-
All Dimensions in mm			

(2) Package type: U-QFN3030-16

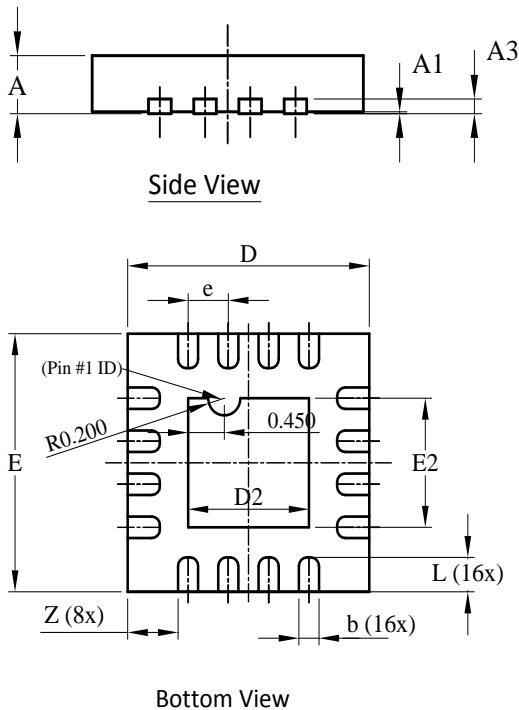

U-QFN3030-16			
Dim	Min	Max	Typ
A	0.55	0.65	0.60
A1	0	0.05	0.02
A3	—	—	0.15
b	0.18	0.28	0.23
D	2.95	3.05	3.00
D2	1.40	1.60	1.50
E	2.95	3.05	3.00
E2	1.40	1.60	1.50
e	—	—	0.50
L	0.35	0.45	0.40
Z	—	—	0.625
All Dimensions in mm			

Suggested Pad Layout

(1) Package type: QSOP-16

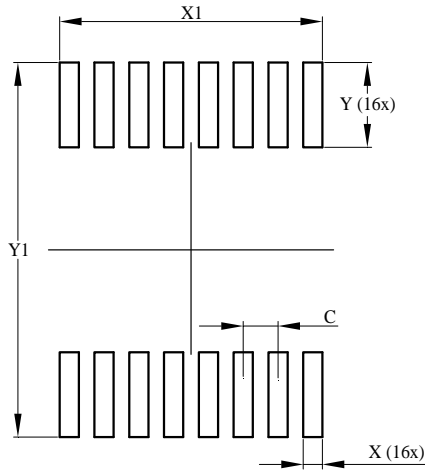

Dimensions	Value (in mm)
C	0.635
X	0.350
X1	4.795
Y	0.1.450
Y1	6.400
All Dimensions in mm	

(2) Package type: U-QFN3030-16

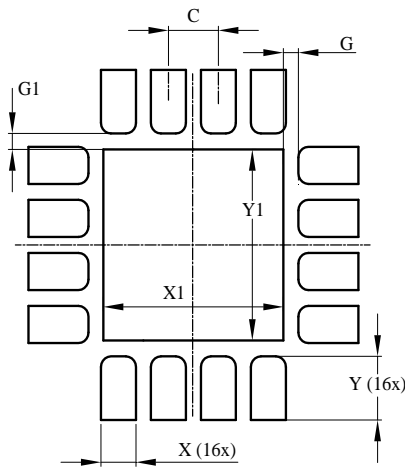

Dimensions	Value (in mm)
C	0.500
G	0.150
G1	0.150
X	0.350
X1	1.800
Y	0.600
Y1	1.800
All Dimensions in mm	

Taping Orientation

For QSOP-16 and U-QFN3030-16

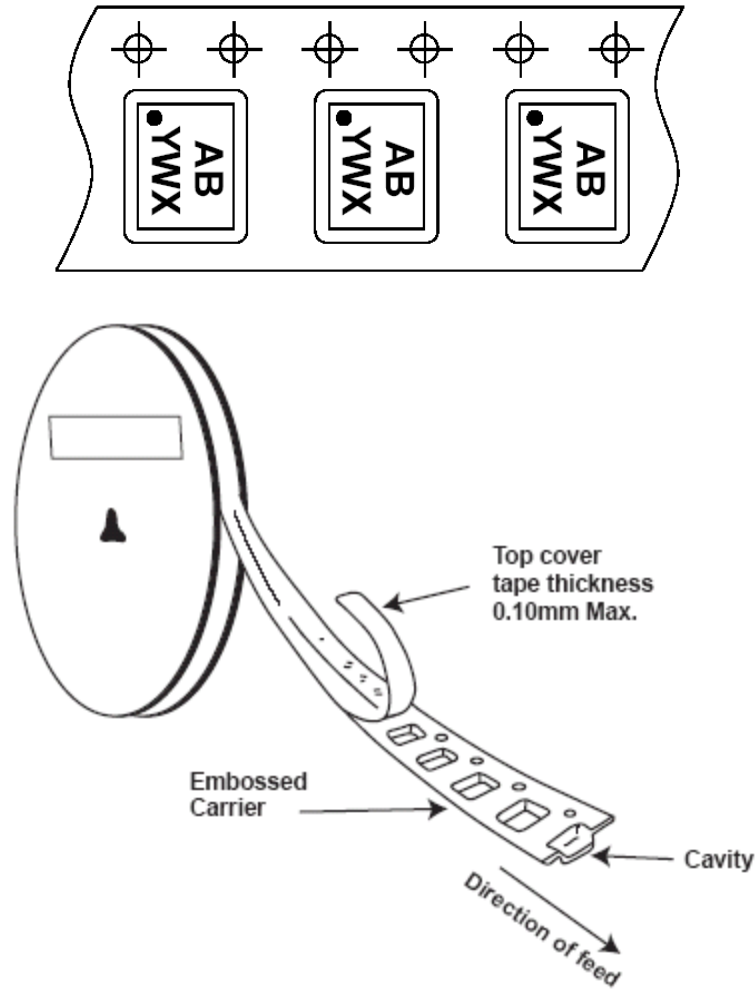

Notes: 10. The taping orientation of the other package type can be found on our website at <http://www.diodes.com/datasheets/ap02007.pdf>.

IMPORTANT NOTICE

DIODES INCORPORATED MAKES NO WARRANTY OF ANY KIND, EXPRESS OR IMPLIED, WITH REGARDS TO THIS DOCUMENT, INCLUDING, BUT NOT LIMITED TO, THE IMPLIED WARRANTIES OF MERCHANTABILITY AND FITNESS FOR A PARTICULAR PURPOSE (AND THEIR EQUIVALENTS UNDER THE LAWS OF ANY JURISDICTION).

Diodes Incorporated and its subsidiaries reserve the right to make modifications, enhancements, improvements, corrections or other changes without further notice to this document and any product described herein. Diodes Incorporated does not assume any liability arising out of the application or use of this document or any product described herein; neither does Diodes Incorporated convey any license under its patent or trademark rights, nor the rights of others. Any Customer or user of this document or products described herein in such applications shall assume all risks of such use and will agree to hold Diodes Incorporated and all the companies whose products are represented on Diodes Incorporated website, harmless against all damages.

Diodes Incorporated does not warrant or accept any liability whatsoever in respect of any products purchased through unauthorized sales channel.

Should Customers purchase or use Diodes Incorporated products for any unintended or unauthorized application, Customers shall indemnify and hold Diodes Incorporated and its representatives harmless against all claims, damages, expenses, and attorney fees arising out of, directly or indirectly, any claim of personal injury or death associated with such unintended or unauthorized application.

Products described herein may be covered by one or more United States, international or foreign patents pending. Product names and markings noted herein may also be covered by one or more United States, international or foreign trademarks.

LIFE SUPPORT

Diodes Incorporated products are specifically not authorized for use as critical components in life support devices or systems without the express written approval of the Chief Executive Officer of Diodes Incorporated. As used herein:

A. Life support devices or systems are devices or systems which:

1. are intended to implant into the body, or
2. support or sustain life and whose failure to perform when properly used in accordance with instructions for use provided in the labeling can be reasonably expected to result in significant injury to the user.

B. A critical component is any component in a life support device or system whose failure to perform can be reasonably expected to cause the failure of the life support device or to affect its safety or effectiveness.

Customers represent that they have all necessary expertise in the safety and regulatory ramifications of their life support devices or systems, and acknowledge and agree that they are solely responsible for all legal, regulatory and safety-related requirements concerning their products and any use of Diodes Incorporated products in such safety-critical, life support devices or systems, notwithstanding any devices- or systems-related information or support that may be provided by Diodes Incorporated. Further, Customers must fully indemnify Diodes Incorporated and its representatives against any damages arising out of the use of Diodes Incorporated products in such safety-critical, life support devices or systems.

Copyright © 2012, Diodes Incorporated

www.diodes.com

Looking for pricing, stock, or lifecycle information?

Click below to explore more details on WIN SOURCE:

- ⊖ [View ZXBM2004JA16TC](#) on WIN SOURCE
- ⊖ [Diodes Incorporated](#) Information

Optimize Your Supply Chain with WIN SOURCE Solutions

- ✓ Global Sourcing Solution
- ✓ Obsolete Management
- ✓ Cost Control Management
- ✓ Shortage Management
- ✓ Alternative Solution
- ✓ Excess Inventory Management