



# ZXBM1004

---

## VARIABLE SPEED SINGLE-PHASE BLDC MOTOR CONTROLLER

---

### DESCRIPTION

The ZXBM1004 is a single-phase, DC brushless motor pre-driver with PWM variable speed control suitable for fan and blower motors. The controller is intended for applications where the fan or blower speed is controlled by an external PWM signal, thermistor or DC voltage.

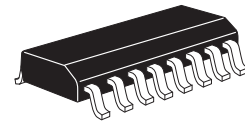

QSOP16

### FEATURES

- Compliant with external PWM speed control
- Compliant with thermistor control
- Minimum speed setting
- Low noise
- Auto restart
- Built in hall amplifier
- Speed pulse (FG) and lock rotor (RD) outputs
- Up to 18V input voltage (60V with external regulator)
- QSOP16 package

### Associated application notes:-

AN41 - Thermistor control

AN42 - External PWM control

AN43 - Interfacing to the motor windings

### APPLICATIONS

- Mainframe and personal computer fans and blowers
- Instrumentation fans
- Central heating blowers
- Automotive climate control

### ORDERING INFORMATION - QSOP16

DEVICE	REEL SIZE	TAPE WIDTH	QUANTITY PER REEL
ZXBM1004Q16TA	7" (180mm)	12mm	500
ZXBM1004Q16TC	13" (330mm)	12mm	2,500

### DEVICE MARKING

- ZETEX  
ZXBM  
1004

# ZXBM1004

## ABSOLUTE MAXIMUM RATINGS

PARAMETER	SYMBOL	LIMITS	UNIT
Supply voltage	$V_{CCmax}$	-0.6 to 20	V
Input current	$I_{CCmax}$	200	mA
Input voltage	$V_{IN max}$	-0.5 to $V_{CC} + 0.5$	V
Output voltage	$V_{OUT max}$	-0.5 to $V_{CC} + 0.5$	V
Power dissipation	$P_{Dmax}$	500	mW
Operating temp.	$T_{OPR}$	-40 to 110	°C
Storage temp.	$T_{STG}$	-55 to 150	°C

### Power Dissipation

1) Maximum allowable Power Dissipation,  $P_D$ , is shown plotted against Ambient Temperature,  $T_A$ , in the accompanying Power Derating Curve, indicating the Safe Operating Area for the device.

2) Power consumed by the device,  $P_T$ , can be calculated from the equation:

$$P_T = P_Q + P_{PhHi} + P_{PhLo}$$

where  $P_Q$  is power dissipated under quiescent current conditions, given by:

$$P_Q = V_{CC} \times I_{CC}$$

where  $V_{CC}$  is the application device Supply Voltage

and  $I_{CC}$  is the maximum Supply Current given in the Electrical Characteristics

and  $P_{PhHi}$  is power generated due to either one of the phase outputs Ph1Hi or Ph2Hi being active, given by:

$$P_{PhHi} = I_{OL} \times V_{OL}$$

where  $I_{OL}$  is the application Ph1Hi and Ph2Hi output currents

and  $V_{OL}$  is the maximum Low Level Output Voltage for the Ph1Hi and Ph2Hi outputs given in the Electrical Characteristics

and  $P_{PhLo}$  is power generated due to either one of the phase outputs Ph1Lo or Ph2Lo being active, given by:

$$P_{PhLo} = I_{OH} \times (V_{CC} - V_{OH})$$

where  $I_{OH}$  is the application Ph1Lo and Ph2Lo output currents

and  $V_{CC}$  is the application device Supply Voltage

and  $V_{OH}$  is the minimum High Level Output Voltage for the Ph1Lo and Ph2Lo outputs given in the Electrical Characteristics



**Power Derating Curve**

# ZXBM1004

## ELECTRICAL CHARACTERISTICS (at $T_{amb} = 25^{\circ}\text{C}$ & $V_{CC} = 12\text{V}$ )

PARAMETER	SYMBOL	MIN.	TYP.	MAX.	UNIT	CONDITIONS
Supply voltage	$V_{CC}$	4.7		18	V	
Supply current	$I_{CC}$		6	8.5	mA	No load <sup>(1)</sup>
Hall amp input voltage	$V_{IN}$	40			mV	diff p-p
Hall amp common mode voltage	$V_{CM}$	0.5		$V_{CC}-1.5$	V	
Hall amp input offset	$V_{OFS}$		$\pm 7$		mV	
Hall amp bias current	$I_{BS}$		400	650	nA	
Ph1Lo, Ph2Lo output high voltage	$V_{OH}$	$V_{CC}-2.2$	$V_{CC}-1.8$		V	$I_{OH}=80\text{mA}$
Ph1Lo, Ph2Lo output low voltage	$V_{OLA}$		0.4	0.6	V	$I_{OL}=16\text{mA}$ <sup>(2)</sup>
Ph1Lo, Ph2Lo output low voltage	$V_{OLB}$		0.4	0.6	V	$I_{OL}=50\mu\text{A}$ <sup>(3)</sup>
Ph1Lo, Ph2Lo output source current	$I_{OH}$			-80	mA	
Ph1Lo, Ph2Lo output sink current	$I_{OL}$			16	mA	
Ph1Hi, Ph2Hi output low voltage	$V_{OL}$		0.5	0.7	V	$I_{OL}=100\text{mA}$
Ph1Hi, Ph2Hi output sink current	$I_{OL}$			100	mA	
$C_{PWM}$ charge current	$I_{PWMC}$	-6.2	-7.6	-9	$\mu\text{A}$	
$C_{PWM}$ discharge current	$I_{PWMD}$	65	80	95	$\mu\text{A}$	
$C_{PWM}$ high threshold voltage	$V_{THH}$	2.95	3	3.15	V	
$C_{PWM}$ low threshold voltage	$V_{THL}$	0.94	1	1.11	V	
PWM frequency	$F_{PWM}$		24		kHz	$C_{PWM}=0.1\text{nF}$
ThRef voltage	$V_{ThRef}$	2.925	3.0	3.14	V	$I_{OThRef}=-100\mu\text{A}$
ThRef output current	$I_{OThRef}$		-0.2	-1	mA	
$S_{MIN}$ input current	$I_{ISMIN}$		-0.25	-0.5	$\mu\text{A}$	$V_{in} = 2\text{V}$
SPD voltage minimum	$V_{SPDL}$		1		V	100% PWM drive
SPD voltage maximum	$V_{SPDH}$		3		V	0% PWM drive
SPD input current	$I_{ISPD}$		-0.8	-2	$\mu\text{A}$	$V_{in} = 2\text{V}$
$C_{LCK}$ charge current	$I_{LCKC}$	-2	-3		$\mu\text{A}$	
$C_{LCK}$ discharge current	$I_{LCKD}$		0.2	0.35	$\mu\text{A}$	
$C_{LCK}$ high threshold voltage	$V_{THH}$		3		V	
$C_{LCK}$ low threshold voltage	$V_{THL}$		1		V	
Lock condition On:Off ratio			1:12			
FG & RD output current	$I_{OL}$			5	mA	
FG & RD low level output voltage	$V_{OL}$			0.5	V	$I_{OI}=5\text{mA}$

Notes:

(1) Measured with pins H+, H-,  $C_{LCK}$  and  $C_{PWM} = 0\text{V}$  and all other signal pins open circuit.

(2) Measured when opposing phase output is low.

(3) Measured when opposing phase output is high.

# ZXBM1004

## Block diagram

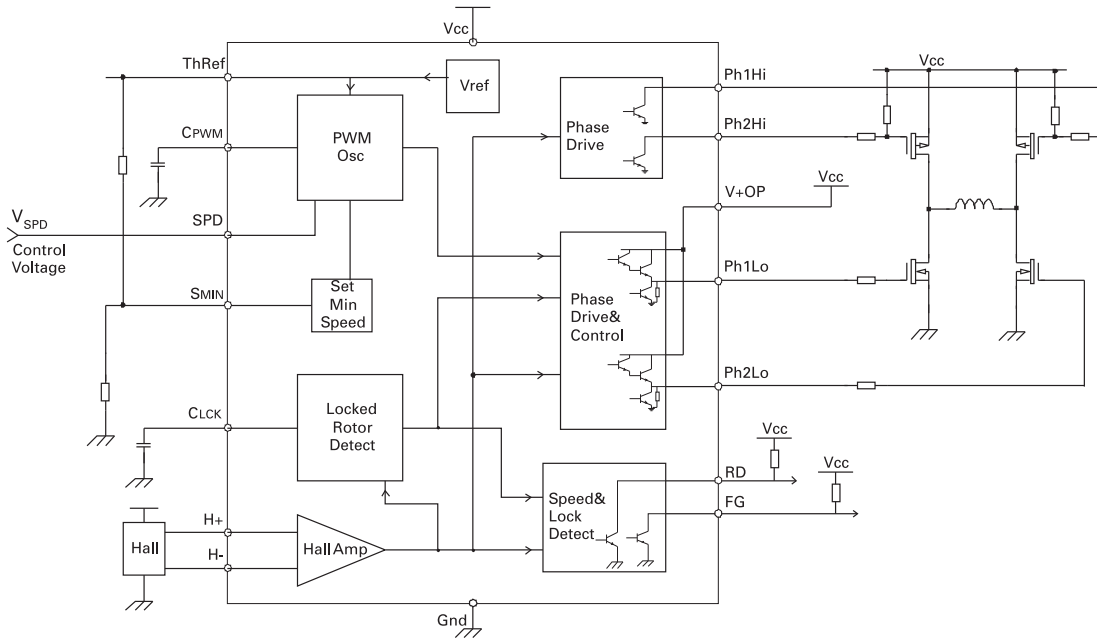

## Pin assignments

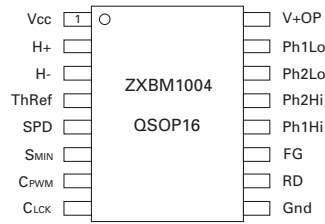

## PIN FUNCTIONAL DESCRIPTION

### H+ - Hall input H- - Hall input

The rotor position is detected by a Hall sensor, with the output applied to the H+ and H- pins. This sensor can be either a 4 pin 'naked' Hall device or of the 3 pin buffered switching type. For a 4 pin device the differential Hall output signal is connected to the H+ and H- pins. For a buffered Hall sensor the Hall device output is attached to the H+ pin, with a pull-up attached if needed, whilst the H- pin has an external potential divider attached to hold the pin at half  $V_{CC}$ . When H+ is high in relation to H-, Ph2 is the active drive.

### ThRef - Network Reference

This is a reference voltage of nominal 3V. It is designed for the ability to 'source' and therefore it will not 'sink' any current from a higher voltage.

The total current drawn from the pin by the minimum speed potential divider to pin  $S_{MIN}$  and any voltage setting network should not exceed 1mA at maximum temperature.

### SPD - Speed Control Input

The voltage applied to the SPD pin provides control over the Fan Motor speed by varying the Pulse Width Modulated (PWM) drive ratio at the Ph1Lo and Ph2Lo outputs. The control signal takes the form of a voltage input of range 3V to 1V, representing 0% to 100% drive respectively.

If variable speed control is not required this pin can be left with an external potential divider to set a fixed speed or tied to ground to provide full speed i.e. 100% PWM drive.

If required this pin can also be used as an enable pin. The application of a voltage >3.0V will force the PWM drive fully off, in effect disabling the drive.

### $S_{MIN}$ - Sets Minimum Speed

A voltage can be set on this pin via a potential divider between the ThRef and Gnd. This voltage is monitored by the SPD pin such that it cannot rise above it. As a higher voltage on the SPD pin represents a lower speed it therefore restricts the lower speed range of the fan. If this feature is not required the pin is left tied to ThRef so no minimum speed will be set.

If the fan is being controlled from an external voltage source onto the SPD pin then either this feature should not be used or if it is required then a >1k $\Omega$  resistor should be placed in series with the SPD pin.

### $C_{PWM}$ - Sets PWM Frequency

This pin has an external capacitor attached to set the PWM frequency for the Phase drive outputs. A capacitor value of 0.1nF will provide a PWM frequency of typically 24kHz.

The  $C_{PWM}$  timing period ( $T_{PWM}$ ) is determined by the following equation:

$$T_{PWM} = \frac{(V_{THH} - V_{THL}) \times C}{I_{PWMC}} + \frac{(V_{THH} - V_{THL}) \times C}{I_{PWMD}}$$

Where:  $C = C_{PWM} + 15$ , in pF  
 $V_{THH}$  and  $V_{THL}$  are the  $C_{PWM}$  pin threshold voltages  
 $I_{PWMC}$  and  $I_{PWMD}$  are the charge and discharge currents in  $\mu A$ .  
 $T_{PWM}$  is in ms

# ZXBM1004

As these threshold voltages are nominally set to  $V_{THH} = 3V$  and  $V_{THL} = 1V$  the equations can be simplified as follows:

$$T_{PWM} = \frac{2C}{I_{PWMC}} + \frac{2C}{I_{PWMD}}$$

## **C<sub>LCK</sub> - Locked rotor timing capacitor**

Should the fan stop rotating for any reason, i.e. an obstruction in the fan blade or a seized bearing, then the device will enter a Rotor Locked condition. In this condition after a predetermined time ( $T_{LOCK}$ ) the RD pin will go high and the Phase outputs will be disabled. After a further delay ( $T_{OFF}$ ) the controller will re-enable the Phase drive for a defined period ( $T_{ON}$ ) in an attempt to re-start the fan. This cycle of ( $T_{OFF}$ ) and ( $T_{ON}$ ) will be repeated indefinitely or until the fan re-starts.

## **GND - Ground**

This is the device supply ground return pin and will generally be the most negative supply pin to the fan.

## **RD - Locked Rotor error output**

This pin is the Locked Rotor output as referred to in the  $C_{LCK}$  timing section above. It is high when the rotor is stopped and low when it is running.

This is an open collector drive giving an active pull down with the high level being provided by an external pull up resistor.

## **FG - Frequency Generator (speed) output**

This is the Frequency Generator output and is a buffered signal from the Hall sensor.

This is an open collector drive giving an active pull down with the high level being provided by an external pull up resistor.

## **Ph1Lo & Ph2Lo - Low-side External H-bridge Driver**

This pair of outputs drive the Low side of the external high power H-bridge devices which in turn drives the single phase winding. These outputs provide both the commutation and PWM waveforms. The outputs are of the Darlington emitter follower type with an active pull-down to help faster switch off when using bipolar devices. When in the high state the outputs will provide up to 80mA of drive into the base or gates of external transistors as shown in the Typical Application circuit following.

When in the low state the active Phase drive is capable of sinking up to 16mA when driving low to aid turn off times during PWM operation. When the Phase is inactive the output is held low by an internal pull-down resistor.

## **Ph1Hi & Ph2Hi - High-side External H-bridge Driver**

These are the High side outputs to the external H-bridge and are open collector outputs capable of sinking 100mA. This signal provides commutation only to the H-bridge.

## **V+OP - Phase Outputs Supply Voltage**

This pin is the supply to the Phase outputs and will be connected differently dependant upon external transistor type.

For bipolar devices this pin will be connected by a resistor to the  $V_{CC}$  pin. The resistor is used to control the current into the transistor base so its value is chosen accordingly.

For MOSFET devices the pin will connect directly to the  $V_{CC}$  pin.

# ZXBM1004

## V<sub>CC</sub> - Applied Voltage

This is the device internal circuitry supply voltage. For 5V to 12V fans this can be supplied directly from the Fan Motor supply. For fans likely to run in excess of the 18V maximum rating for the device this will be supplied from an external regulator such as a Zener diode.

## RD Timing Waveform:

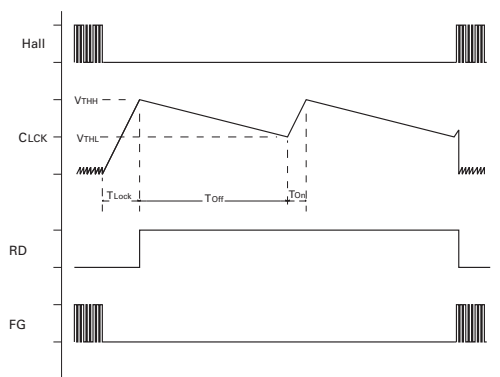

## Applications Information

The ZXBM1004 is primarily controlled by a voltage on the SPD pin. A voltage of 1V represents a 100% PWM at the Phase Outputs and in turn represents full speed. 3V on the SPD pin conversely represents 0% PWM. The motor can therefore be controlled simply by applying a control voltage onto the SPD pin with the minimal use of external components.

This voltage control method easily lends itself to control by other signal types. For example if a thermistor is applied to the SPD pin a varying voltage can be generated at the SPD pin as the resistance of the thermistor varies with temperature.

A common form of control of fans is by a PWM signal derived from a central processor or controller. This signal can be converted into a voltage and that voltage adjusted as necessary to compensate for motor non linearity, inclusion of the Minimum speed feature etc.

Full applications details and further examples of how to control the ZXBM1004 are available in the Applications Notes AN41, AN42 and AN43.

# ZXBM1004

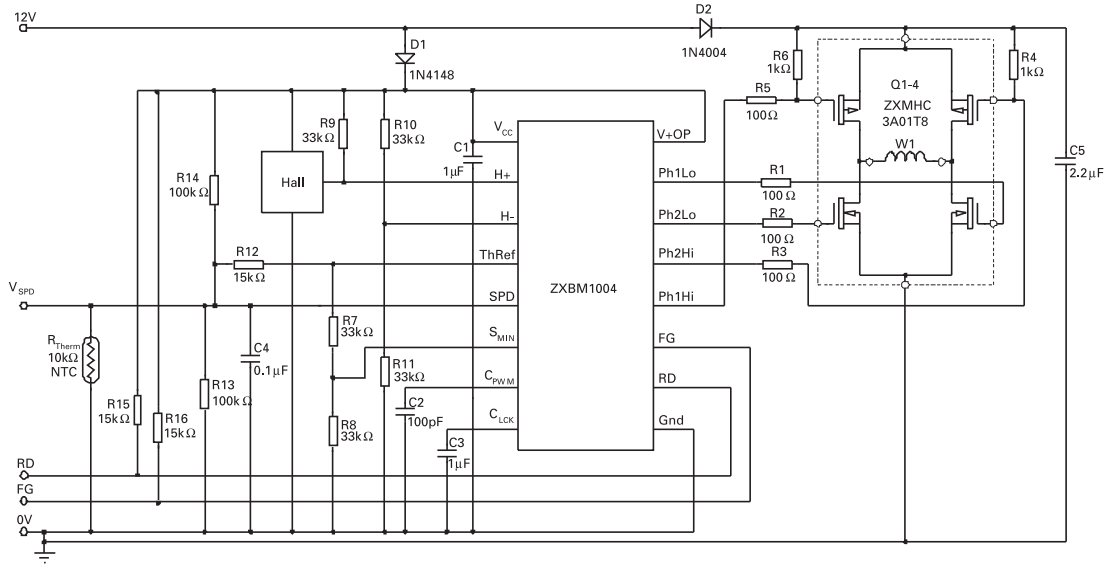

Figure 1: Typical circuit for thermistor controlled speed

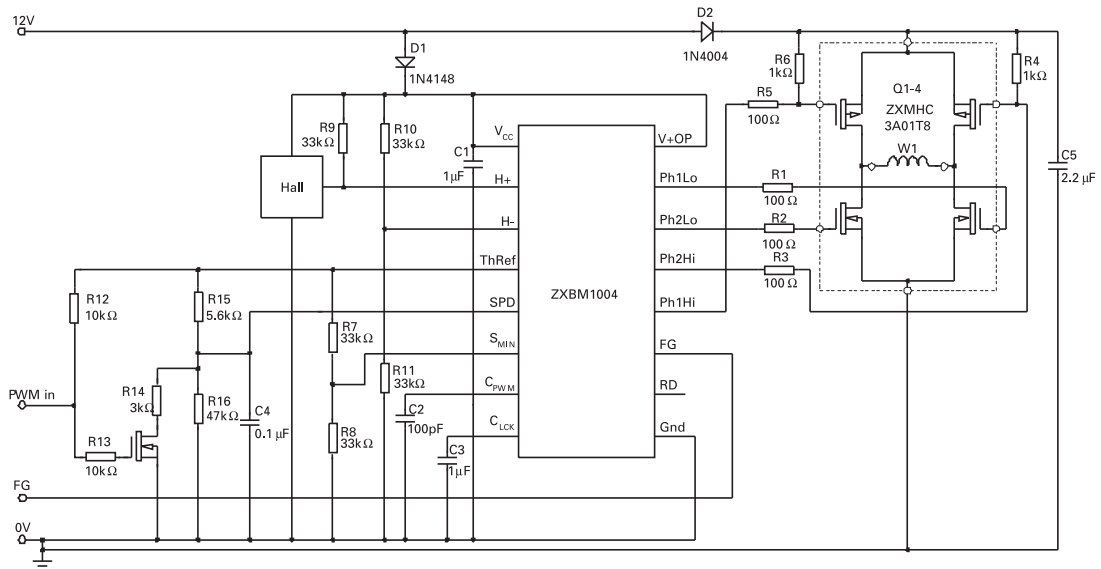

Figure 2: Typical circuit for external PWM controlled speed

# ZXBM1004

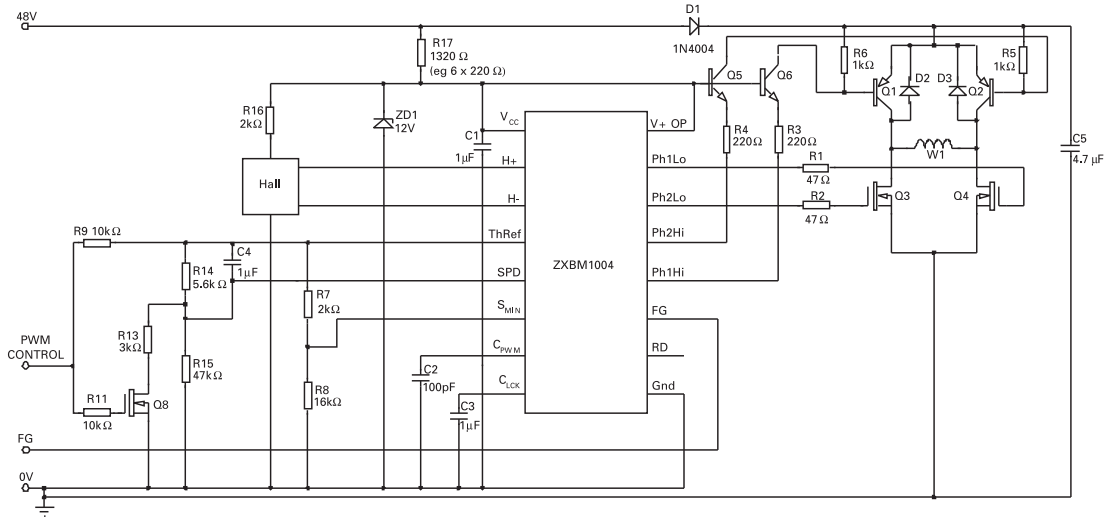

Figure 3: Typical circuit for 48V input and external PWM control

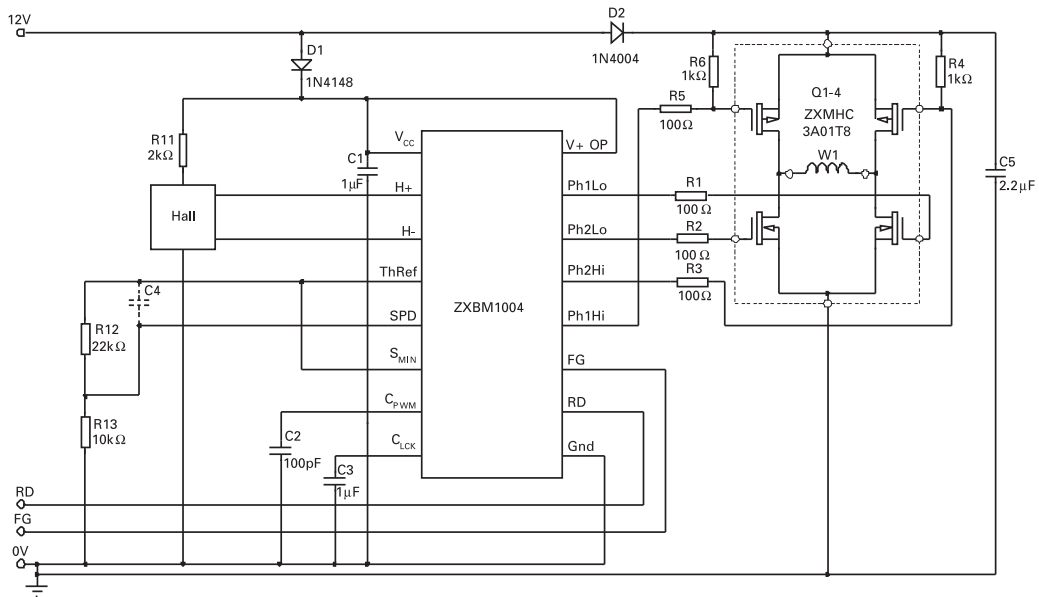

Figure 4: Typical circuit for constant speed operation

# ZXBM1004

## Drive transistors

Zetex offers a range of devices that are ideally suited to interface between the ZXBM1004 controller and the motor. The following tables show a selection of products ranging from single packaged H-bridge devices to individual power components that can be used in this application. If your needs are not covered by this selection then please refer to the more comprehensive listings that can be found on the Zetex website: [www.zetex.com](http://www.zetex.com)

Description	Part Number	Content	$BV_{DSS}$ V	$I_D$ A	$I_{DM}$ A	$R_{DS(on)}$ @ $V_{GS}=10V$ max. $m\Omega$	Package
MOSFET H-Bridge	ZXMHC6A07T8	2 x N	60	1.8	8.7	300	SM-8
		2 x P	-60	-1.5	-7.5	425	
	ZXMHC3A01T8	2 x N	30	3.1	14.5	120	SM-8
		2 x P	-30	-2.3	-10.8	210	
N + P channel MOSFET	ZXMC4559DN8	N	60	4.7	22	55	SO8
		P	-60	-3.5	-18	105	
	ZXMC3A16DN8	N	30	6.4	30	35	SO8
		P	-30	-5.4	-25	48	
Low side switch MOSFET	ZXMN10A09K	N	100	7.7	27	85	DPAK
	ZXMN6A09K	N	60	11.2	40	45	
	ZXMN3A04K	N	30	18.4	66	20	

Description	Part Number	Content	$BV_{CEO}$ V	$I_C$ A	$I_{CM}$ A	$V_{CE(sat)}$ at $I_C=2A$ max. mV	Package
High side switch Bipolar	ZXT953K	PNP	-100	-5	-10	-175	DPAK
	ZXT951K	PNP	-60	-6	-15	-165	
	ZXT790AK	PNP	-40	-3	-6	-450	

## Definitions

### Product change

Zetex Semiconductors reserves the right to alter, without notice, specifications, design, price or conditions of supply of any product or service. Customers are solely responsible for obtaining the latest relevant information before placing orders.

### Applications disclaimer

The circuits in this design/application note are offered as design ideas. It is the responsibility of the user to ensure that the circuit is fit for the user's application and meets with the user's requirements. No representation or warranty is given and no liability whatsoever is assumed by Zetex with respect to the accuracy or use of such information, or infringement of patents or other intellectual property rights arising from such use or otherwise. Zetex does not assume any legal responsibility or will not be held legally liable (whether in contract, tort (including negligence), breach of statutory duty, restriction or otherwise) for any damages, loss of profit, business, contract, opportunity or consequential loss in the use of these circuit applications, under any circumstances.

### Life support

Zetex products are specifically not authorized for use as critical components in life support devices or systems without the express written approval of the Chief Executive Officer of Zetex Semiconductors plc. As used herein:

A. Life support devices or systems are devices or systems which:

1. are intended to implant into the body  
or
2. support or sustain life and whose failure to perform when properly used in accordance with instructions  
for use provided in the labeling can be reasonably expected to result in significant injury to the user.

B. A critical component is any component in a life support device or system whose failure to perform can be reasonably expected to cause the failure of the life support device or to affect its safety or effectiveness.

### Reproduction

The product specifications contained in this publication are issued to provide outline information only which (unless agreed by the company in writing) may not be used, applied or reproduced for any purpose or form part of any order or contract or be regarded as a representation relating to the products or services concerned.

### Terms and Conditions

All products are sold subjects to Zetex' terms and conditions of sale, and this disclaimer (save in the event of a conflict between the two when the terms of the contract shall prevail) according to region, supplied at the time of order acknowledgement.

For the latest information on technology, delivery terms and conditions and prices, please contact your nearest Zetex sales office.

### Quality of product

Zetex is an ISO 9001 and TS16949 certified semiconductor manufacturer.

To ensure quality of service and products we strongly advise the purchase of parts directly from Zetex Semiconductors or one of our regionally authorized distributors. For a complete listing of authorized distributors please visit: [www.zetex.com/salesnetwork](http://www.zetex.com/salesnetwork)

Zetex Semiconductors does not warrant or accept any liability whatsoever in respect of any parts purchased through unauthorized sales channels.

### ESD (Electrostatic discharge)

Semiconductor devices are susceptible to damage by ESD. Suitable precautions should be taken when handling and transporting devices. The possible damage to devices depends on the circumstances of the handling and transporting, and the nature of the device. The extent of damage can vary from immediate functional or parametric malfunction to degradation of function or performance in use over time. Devices suspected of being affected should be replaced.

### Green compliance

Zetex Semiconductors is committed to environmental excellence in all aspects of its operations which includes meeting or exceeding regulatory requirements with respect to the use of hazardous substances. Numerous successful programs have been implemented to reduce the use of hazardous substances and/or emissions.

All Zetex components are compliant with the RoHS directive, and through this it is supporting its customers in their compliance with WEEE and ELV directives.

### Product status key:

"Preview"Future device intended for production at some point. Samples may be available

"Active"Product status recommended for new designs

"Last time buy (LTB)"Device will be discontinued and last time buy period and delivery is in effect

"Not recommended for new designs"Device is still in production to support existing designs and production

"Obsolete"Production has been discontinued

Datasheet status key:

"Draft version" This term denotes a very early datasheet version and contains highly provisional information, which may change in any manner without notice.

"Provisional version" This term denotes a pre-release datasheet. It provides a clear indication of anticipated performance. However, changes to the test conditions and specifications may occur, at any time and without notice.

"Issue" This term denotes an issued datasheet containing finalized specifications. However, changes to specifications may occur, at any time and without notice.

# ZXBM1004

## PACKAGE OUTLINE QSOP16

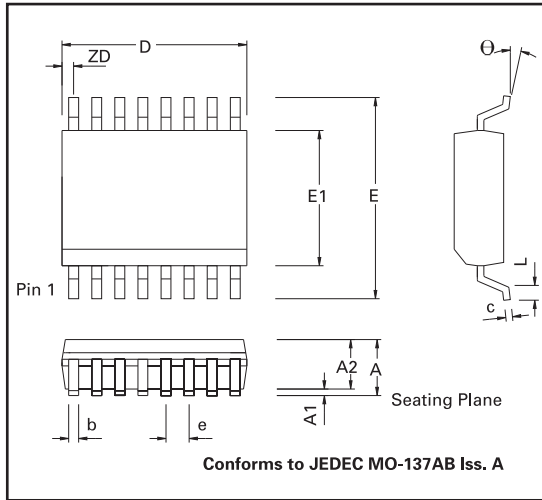

## PACKAGE DIMENSIONS

Dim	Inches		Millimeters	
	Min.	Max.	Min.	Max.
A	0.053	0.069	1.35	1.75
A1	0.004	0.010	0.10	0.25
A2	0.049	0.059	1.25	1.50
D	0.189	0.197	4.80	5.00
ZD	0.009 Ref		0.23 BSC	
E	0.228	0.244	5.79	6.20
E1	0.150	0.157	3.81	3.99
L	0.016	0.050	0.41	1.27
e	0.025 BSC		0.64 BSC	
b	0.008	0.012	0.20	0.30
c	0.007	0.010	0.18	0.25
$\theta$	0°	8°	0°	8°

**Note:** Dimensions in inches are control dimensions, dimensions in millimeters are approximate.

© Zetex Semiconductors plc 2007



Europe	Americas	Asia Pacific	Corporate Headquarters
Zetex GmbH Kustermann-Park Balanstraße 59 D-81541 München Germany Telefon: (49) 89 45 49 49 0 Fax: (49) 89 45 49 49 49 europe.sales@zetex.com	Zetex Inc 700 Veterans Memorial Hwy Hauppauge, NY 11788 USA Telephone: (1) 631 360 2222 Fax: (1) 631 360 8222 usa.sales@zetex.com	Zetex (Asia) Ltd 3701-04 Metroplaza Tower 1 Hing Fong Road, Kwai Fong Hong Kong Telephone: (852) 26100 611 Fax: (852) 24250 494 asia.sales@zetex.com	Zetex Semiconductors plc Zetex Technology Park Chadderton, Oldham, OL9 9LL United Kingdom Telephone (44) 161 622 4444 Fax: (44) 161 622 4446 hq@zetex.com



ISSUE 6 - MAY 2007

## Looking for pricing, stock, or lifecycle information?

Click below to explore more details on WIN SOURCE:

-  [View ZXBM1004Q16TC on WIN SOURCE](#)
-  [Diodes Incorporated Information](#)

## Optimize Your Supply Chain with WIN SOURCE Solutions

-  Global Sourcing Solution
-  Obsolete Management
-  Cost Control Management
-  Shortage Management
-  Alternative Solution
-  Excess Inventory Management