



**THE DATASHEET OF
ZR431LF02TA**



Description

The ZR431L is a three terminal adjustable shunt regulator offering excellent temperature stability and output current handling capability up to 25mA. The output voltage may be set to any chosen voltage between 1.24 and 10 volts by selection of two external divider resistors.

The devices can be used as a replacement for zener diodes in many applications requiring an improvement in zener performance.

The ZR431L is particularly used in the feedback control loop of switch mode power supplies. In this application the device 1.24 volt reference enables the generation of low voltage supplies, typically 3.3 volts or 3 volts.

Features

- 2.5% and 1% Tolerance
- Max. Temperature Coefficient 50ppm/°C
- Temperature Compensated for Operation over The Full Temperature Range
- Programmable Output Voltage
- 100µA to 100mA Current Sink Capability
- Surface Mount SOT23 Package
- **Totally Lead-Free & Fully RoHS Compliant (Notes 1 & 2)**
- **Halogen and Antimony Free. "Green" Device (Note 3)**

- Notes:
1. No purposely added lead. Fully EU Directive 2002/95/EC (RoHS) & 2011/65/EU (RoHS 2) compliant.
 2. See http://www.diodes.com/quality/lead_free.html for more information about Diodes Incorporated's definitions of Halogen- and Antimony-free, "Green" and Lead-free.
 3. Halogen- and Antimony-free "Green" products are defined as those which contain <900ppm bromine, <900ppm chlorine (<1500ppm total Br + Cl) and <1000ppm antimony compounds.

Pin Assignments

(Top View)

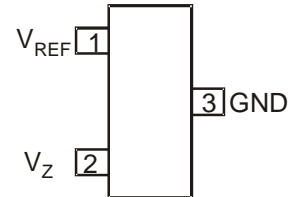

SOT23

Applications

- Shunt Regulator
- Series Regulator
- Voltage Monitor
- Over Voltage/ Under Voltage Protection
- Switch Mode Power Supplies

Typical Applications Circuit

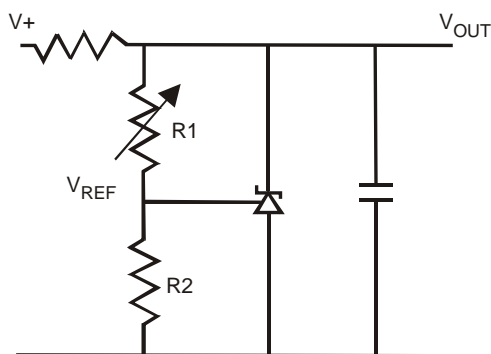

$$V_{OUT} = \left(1 + \frac{R_1}{R_2}\right) V_{REF}$$

SHUNT REGULATOR

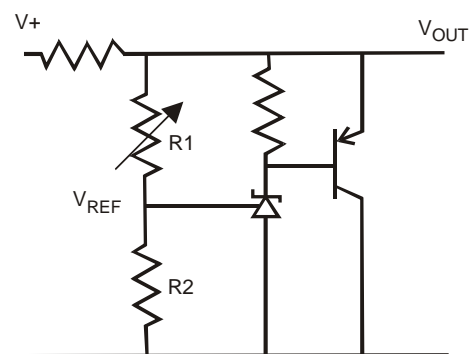

$$V_{OUT} = \left(1 + \frac{R_1}{R_2}\right) V_{REF}$$

HIGHER CURRENT SHUNT REGULATOR

Typical Applications Circuit (cont.)

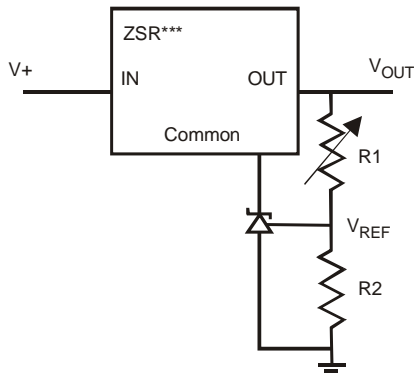

$$V_{OUT(MIN)} = V_{REF} + V_{REG}$$

$$V_{OUT} = \left(1 + \frac{R1}{R2}\right) V_{REF}$$

OUTPUT CONTROL OF A THREE TERMINAL FIXED REGULATOR

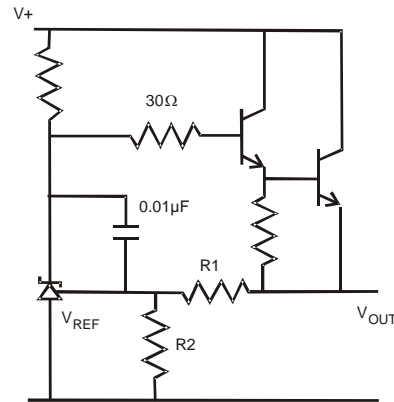

$$V_{OUT} = \left(1 + \frac{R1}{R2}\right) V_{REF}$$

SERIES REGULATOR

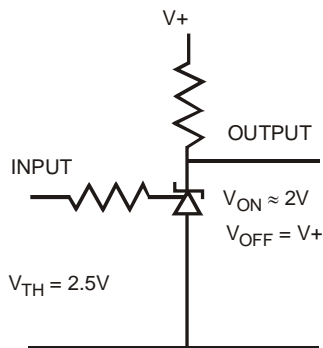

SINGLE SUPPLY COMPARATOR WITH TEMPERATURE COMPENSATED THRESHOLD

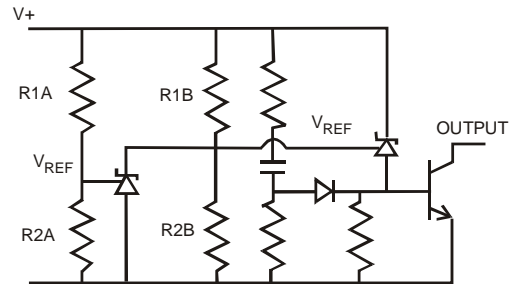

$$\text{Low limit} + \left(1 + \frac{R1B}{R2B}\right) V_{REF}$$

$$\text{High limit} + \left(1 + \frac{R1A}{R2A}\right) V_{REF}$$

OVER VOLTAGE/UNDER VOLTAGE PROTECTION CIRCUIT

Functional Block Diagram

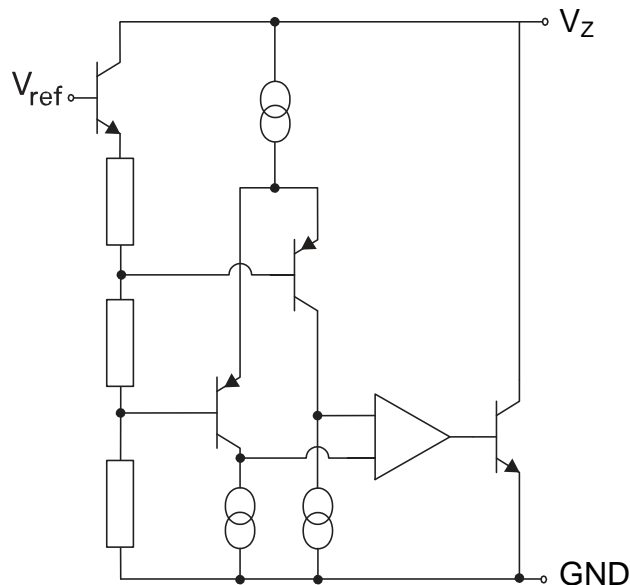

Absolute Maximum Ratings (@T_A = +25°C, unless otherwise specified.) (Note 4)

Symbol	Parameter	Rating	Unit
V _Z	Cathode Voltage	10	V
I _Z	Cathode Current	50	mA
T _J	Junction Temperature	-40 to +125	°C
T _{STG}	Storage Temperature	-55 to +105	°C
θ _{JA}	Thermal Resistance	SOT23	380 °C/W

Note 4: Stresses beyond those listed under Absolute Maximum Ratings may cause permanent damage to the device. These are stress ratings only and functional operation of the device at these conditions is not implied. Exposure to absolute-maximum-rated conditions for extended periods may affect device reliability.

Recommended Operating Conditions (@T_A = +25°C, unless otherwise specified.)

Symbol	Parameter	Min	Max	Unit
V _Z	Cathode Voltage	V _{REF}	10	V
I _Z	Cathode Current	0.1	25	mA
T _A	Operating Temperature	-40	+85	°C

Electrical Characteristics (@T_A = +25°C, unless otherwise specified.)

Symbol	Parameter	Test Conditions	Min	Typ.	Max	Unit	
V _{REF}	Reference Voltage	I _L = 10mA (Figure 1), V _Z = V _{REF}	2.5%	1.209	1.24	1.271	V
			1%	1.228	1.24	1.252	
V _{DEV}	Deviation of Reference Input Voltage Over Temperature	I _L = 10mA, V _Z = V _{REF} T _A = Full range (Figure 1)	–	4	8	mV	
$\frac{\Delta V_{REF}}{\Delta V_Z}$	Ratio of The Change in Reference Voltage to The Change in Cathode Voltage	V _Z from V _{REF} to 10V I _Z = 10mA (Figure 2)	–	0.5	2	mV/V	
I _{REF}	Reference Input Current	R1 = 10k, R2 = O/C, I _L = 10mA (Figure 2)	0.02	0.11	0.4	µA	
ΔI _{REF}	Deviation of Reference Input Current over Temperature	R1 = 10k, R2 = O/C, I _L = 10mA T _A = Full range (Figure 2)	–	0.02	0.2	µA	
I _{Z(MIN)}	Minimum Cathode Current for Regulation	V _Z = V _{REF} (Figure 1)	–	30	100	µA	
I _{Z(OFF)}	Off-state Current	V _Z = 10V, V _{REF} = 0V (Figure 3)	–	10	30	µA	
R _Z	Dynamic Output Impedance	V _Z = V _{REF} (Figure 1), f = 0Hz	–	0.25	2	Ω	

For definitions of reference voltage temperature coefficient and dynamic output impedance see NOTES following DC TEST CIRCUITS.

DC Test Circuits

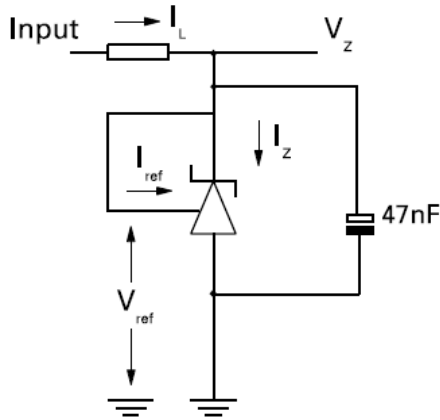

Figure 1. Test Circuit for $V_Z = V_{REF}$

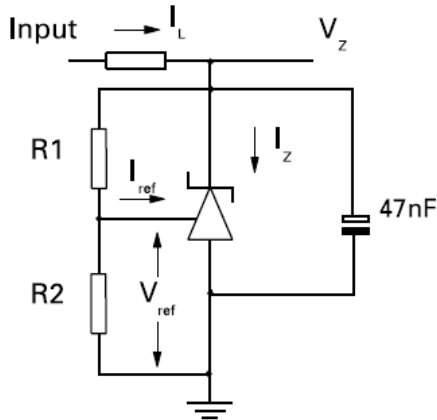

Figure 2. Test Circuit for $V_Z > V_{REF}$

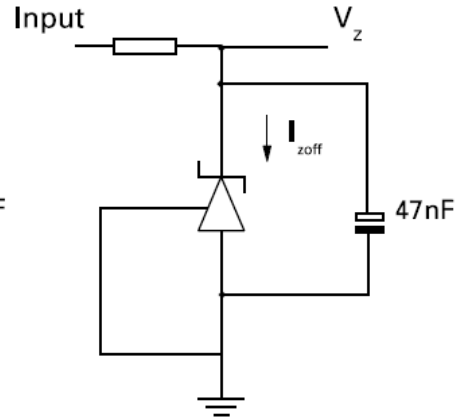
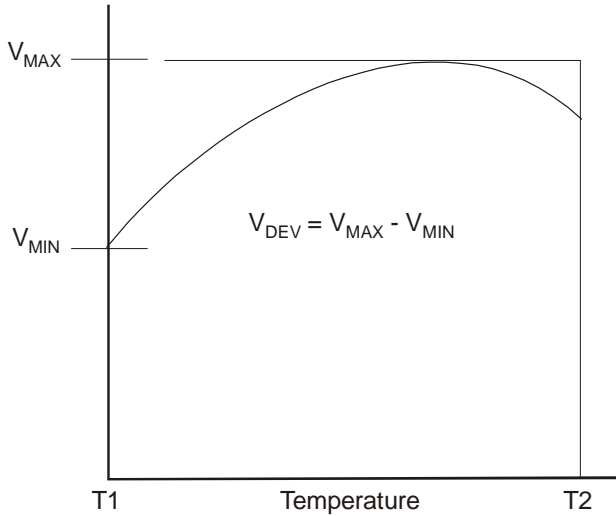

Figure 3. Test Circuit for Off State Current

Deviation of reference input voltage, V_{DEV} , is defined as the maximum variation of the reference input voltage over the full temperature range.

The average temperature coefficient of the reference input voltage, V_{REF} is defined as:



$$V_{ref} \text{ (ppm/}^\circ\text{C)} = \frac{V_{dev} \times 1000000}{V_{ref} (T1 - T2)}$$

The dynamic output impedance, R_z is defined as:

$$R_z = \frac{\Delta V_z}{\Delta I_z}$$

When the device is programmed with two external resistors, R_1 and R_2 (Figure 2), the dynamic output impedance of the overall circuit, R' , is defined as:

$$R' = R_z \left(1 + \frac{R_1}{R_2} \right)$$

Performance Characteristics

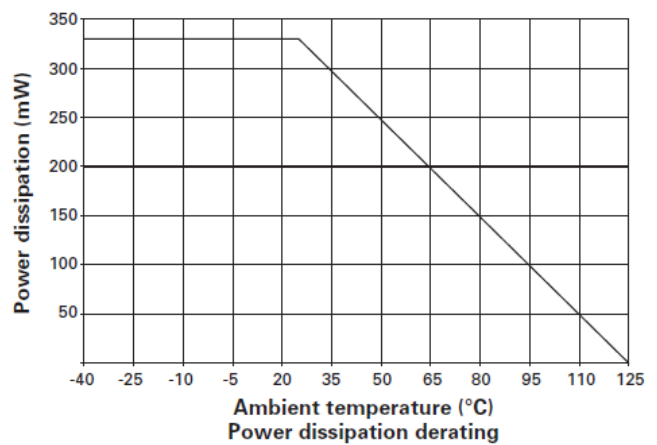
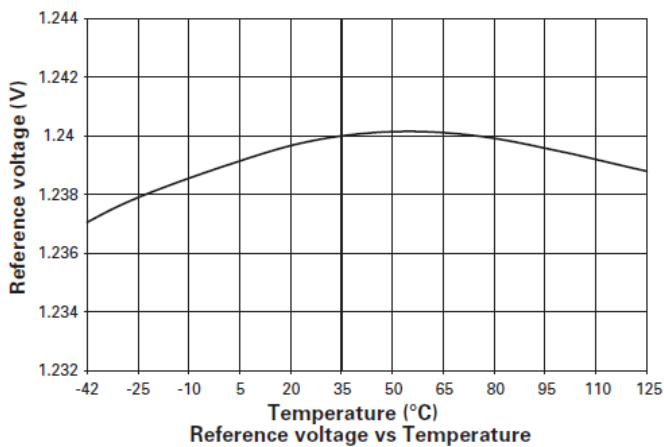
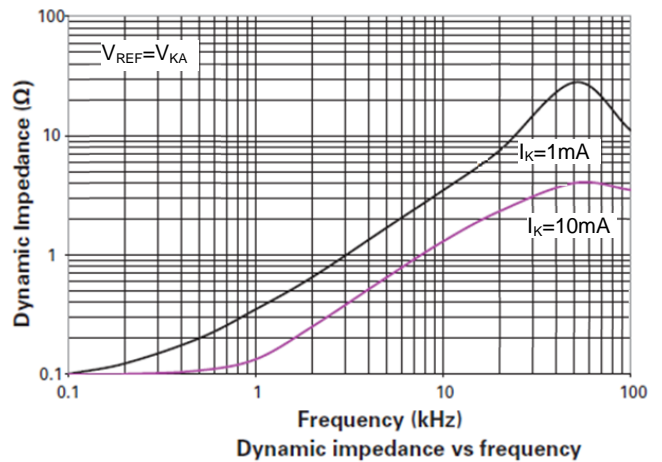
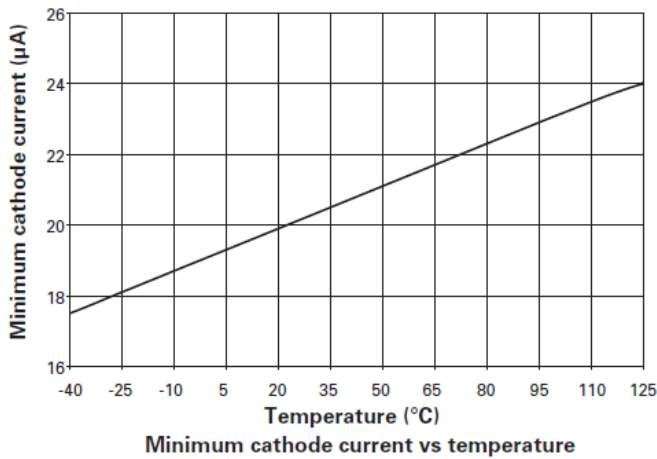
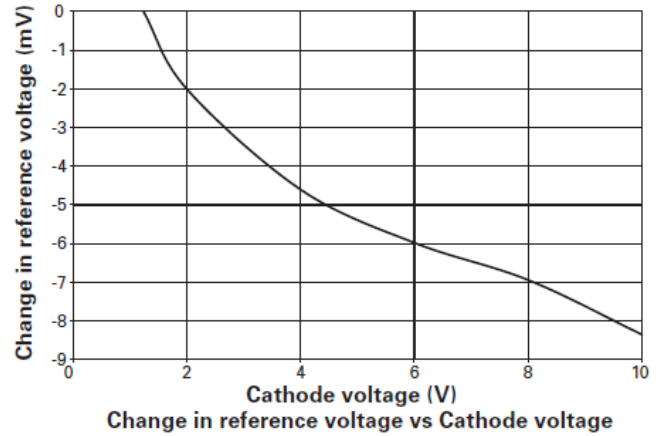
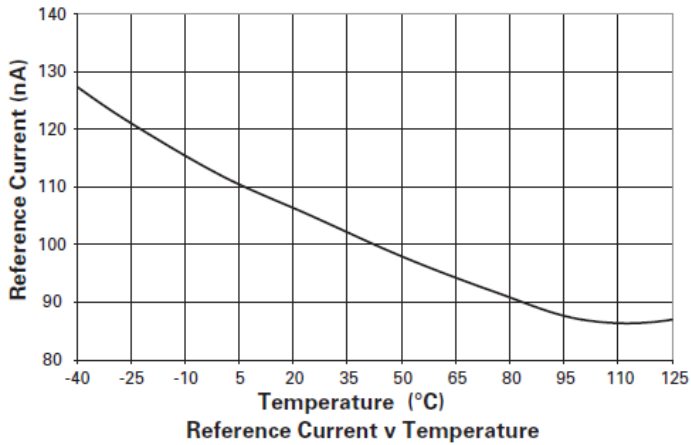

Performance Characteristics (cont.)

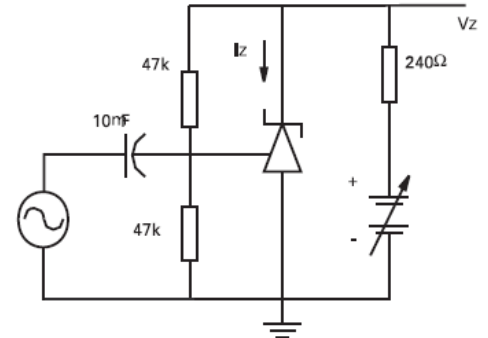
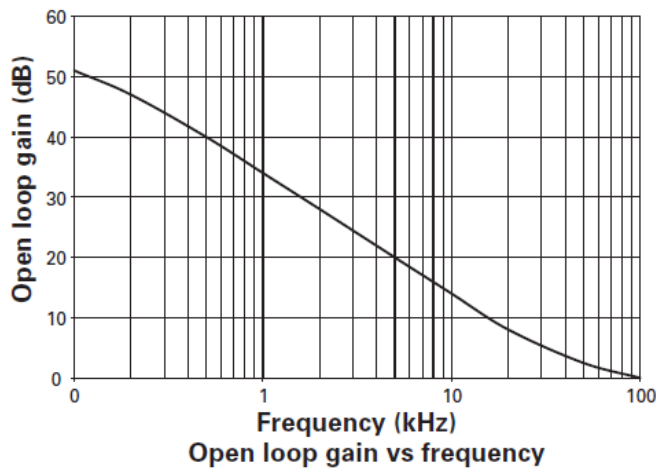

$I_z = 10\text{mA}$, $T_A = 25^\circ\text{C}$

Test Circuit for Open Loop Voltage Gain

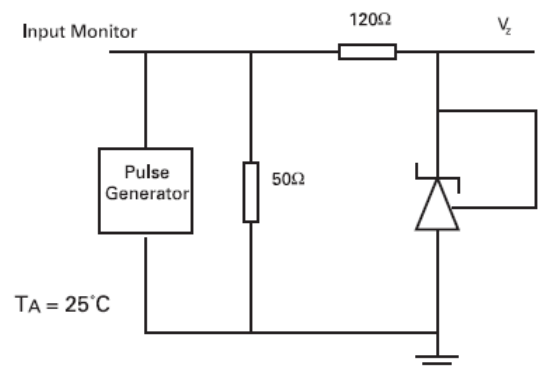
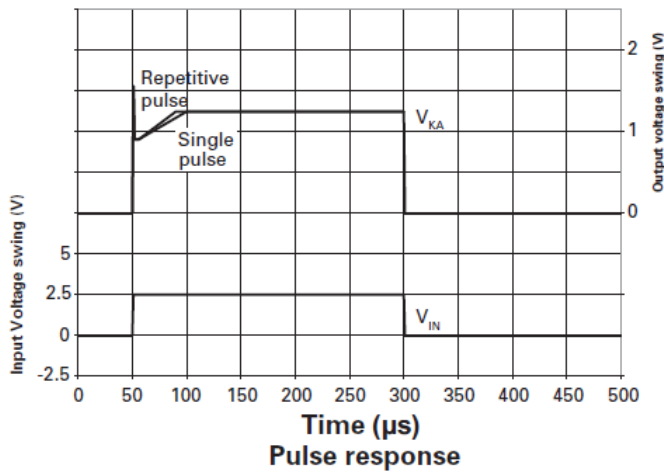

Test Circuit for Pulse Response

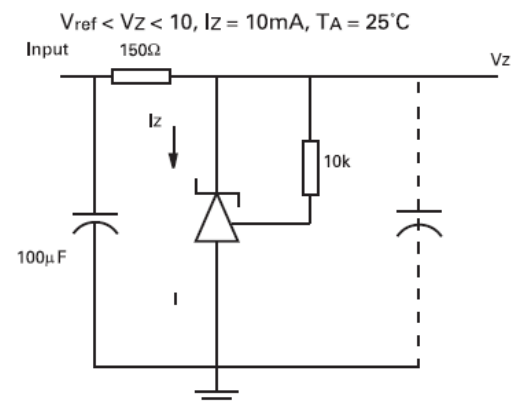
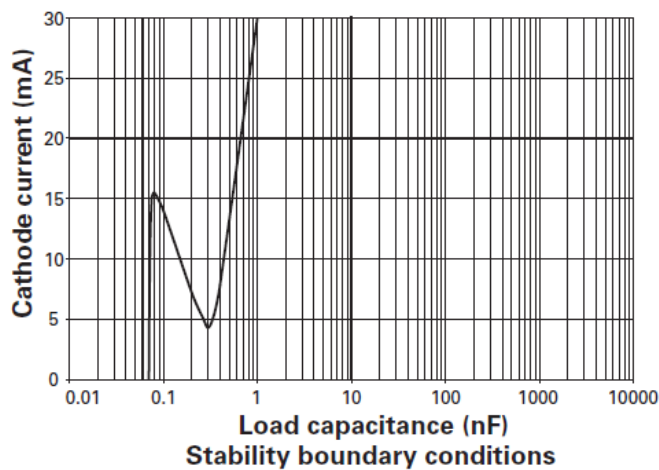

Test Circuit for Stability Boundary Conditions

Ordering Information

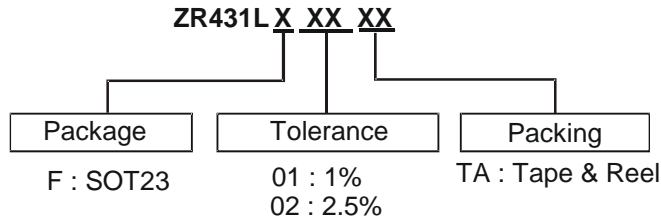

Part Number	Tolerance	Package Code	Part Mark	Packaging	7" Tape and Reel	
					Quantity	Part Number Suffix
ZR431LF01TA	1%	F	43M	SOT23	3000/Tape & Reel	TA
ZR431LF02TA	2.5%	F	43L	SOT23	3000/Tape & Reel	TA

Marking Information

(Top View)

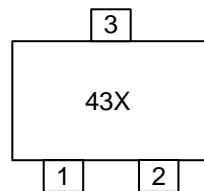

43: Identification Code
 X: Voltage Tolerance
 M : 1%
 L : 2.5%

Package Outline Dimensions

Please see AP02002 at <http://www.diodes.com/datasheets/ap02002.pdf> for the latest version.

(1) Package Type: SOT23

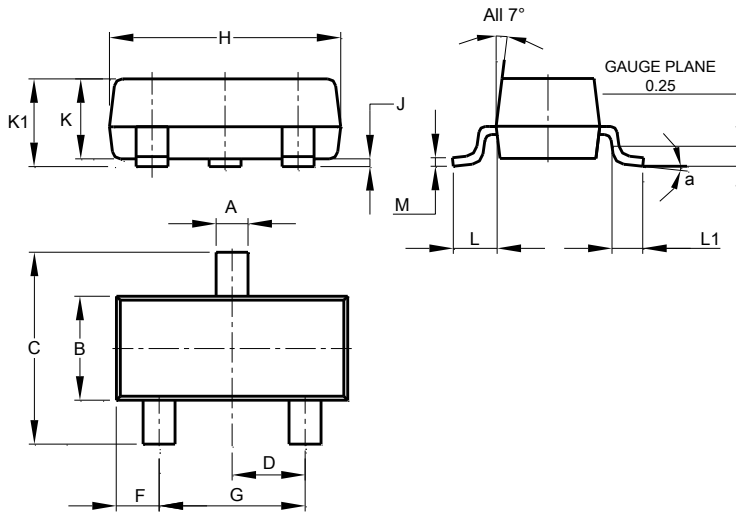

SOT23			
Dim	Min	Max	Typ
A	0.37	0.51	0.40
B	1.20	1.40	1.30
C	2.30	2.50	2.40
D	0.89	1.03	0.915
F	0.45	0.60	0.535
G	1.78	2.05	1.83
H	2.80	3.00	2.90
J	0.013	0.10	0.05
K	0.890	1.00	0.975
K1	0.903	1.10	1.025
L	0.45	0.61	0.55
L1	0.25	0.55	0.40
M	0.085	0.150	0.110
a	8°		
All Dimensions in mm			

Suggested Pad Layout

Please see AP02001 at <http://www.diodes.com/datasheets/ap02001.pdf> for the latest version.

(1) Package Type: SOT23

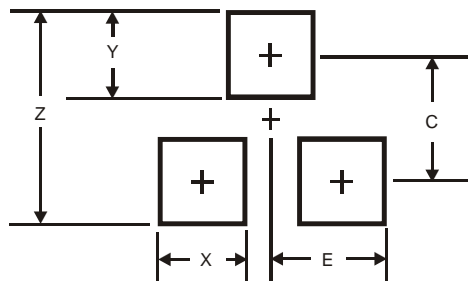

Dimensions	Value (in mm)
Z	2.9
X	0.8
Y	0.9
C	2.0
E	1.35

IMPORTANT NOTICE

DIODES INCORPORATED MAKES NO WARRANTY OF ANY KIND, EXPRESS OR IMPLIED, WITH REGARDS TO THIS DOCUMENT, INCLUDING, BUT NOT LIMITED TO, THE IMPLIED WARRANTIES OF MERCHANTABILITY AND FITNESS FOR A PARTICULAR PURPOSE (AND THEIR EQUIVALENTS UNDER THE LAWS OF ANY JURISDICTION).

Diodes Incorporated and its subsidiaries reserve the right to make modifications, enhancements, improvements, corrections or other changes without further notice to this document and any product described herein. Diodes Incorporated does not assume any liability arising out of the application or use of this document or any product described herein; neither does Diodes Incorporated convey any license under its patent or trademark rights, nor the rights of others. Any Customer or user of this document or products described herein in such applications shall assume all risks of such use and will agree to hold Diodes Incorporated and all the companies whose products are represented on Diodes Incorporated website, harmless against all damages.

Diodes Incorporated does not warrant or accept any liability whatsoever in respect of any products purchased through unauthorized sales channel. Should Customers purchase or use Diodes Incorporated products for any unintended or unauthorized application, Customers shall indemnify and hold Diodes Incorporated and its representatives harmless against all claims, damages, expenses, and attorney fees arising out of, directly or indirectly, any claim of personal injury or death associated with such unintended or unauthorized application.

Products described herein may be covered by one or more United States, international or foreign patents pending. Product names and markings noted herein may also be covered by one or more United States, international or foreign trademarks.

This document is written in English but may be translated into multiple languages for reference. Only the English version of this document is the final and determinative format released by Diodes Incorporated.

LIFE SUPPORT

Diodes Incorporated products are specifically not authorized for use as critical components in life support devices or systems without the express written approval of the Chief Executive Officer of Diodes Incorporated. As used herein:

A. Life support devices or systems are devices or systems which:

1. are intended to implant into the body, or
2. support or sustain life and whose failure to perform when properly used in accordance with instructions for use provided in the labeling can be reasonably expected to result in significant injury to the user.

B. A critical component is any component in a life support device or system whose failure to perform can be reasonably expected to cause the failure of the life support device or to affect its safety or effectiveness.

Customers represent that they have all necessary expertise in the safety and regulatory ramifications of their life support devices or systems, and acknowledge and agree that they are solely responsible for all legal, regulatory and safety-related requirements concerning their products and any use of Diodes Incorporated products in such safety-critical, life support devices or systems, notwithstanding any devices- or systems-related information or support that may be provided by Diodes Incorporated. Further, Customers must fully indemnify Diodes Incorporated and its representatives against any damages arising out of the use of Diodes Incorporated products in such safety-critical, life support devices or systems.

Copyright © 2015, Diodes Incorporated

www.diodes.com

Looking for pricing, stock, or lifecycle information?

Click below to explore more details on WIN SOURCE:

-  [View ZR431LF02TA on WIN SOURCE](#)
-  [Diodes Incorporated Information](#)

Optimize Your Supply Chain with WIN SOURCE Solutions

-  Global Sourcing Solution
-  Obsolete Management
-  Cost Control Management
-  Shortage Management
-  Alternative Solution
-  Excess Inventory Management