



**THE DATASHEET OF
ZNBG3000Q16TC**



FET BIAS CONTROLLER

ZNBG3000
ZNBG3001

ISSUE 1- AUGUST 1998

DEVICE DESCRIPTION

The ZNBG series of devices are designed to meet the bias requirements of GaAs and HEMT FETs commonly used in satellite receiver LNBS, PMR, cellular telephones etc. with a minimum of external components.

With the addition of two capacitors and a resistor the devices provide drain voltage and current control for 3 external grounded source FETs, generating the regulated negative rail required for FET gate biasing whilst operating from a single supply. This negative bias, at -3 volts, can also be used to supply other external circuits.

The ZNBG3000/1 contains three bias stages. A single resistor allows FET drain current to be set to the desired level. The series also offers the choice of drain voltage to be set for the FETs, the ZNBG3000 gives 2.2 volts drain whilst the ZNBG3001 gives 2 volts.

These devices are unconditionally stable over the full working temperature with the FETs in place, subject to the inclusion of the recommended gate and drain capacitors. These ensure RF stability and minimal injected noise.

It is possible to use less than the devices full complement of FET bias controls, unused drain and gate connections can be left open circuit without affecting operation of the remaining bias circuits.

In order to protect the external FETs the circuits have been designed to ensure that, under any conditions including power up/down transients, the gate drive from the bias circuits cannot exceed the range -3.5V to 0.7V. Furthermore if the negative rail experiences a fault condition, such as overload or short circuit, the drain supply to the FETs will shut down avoiding excessive current flow.

The ZNBG3000/1 are available in QSOP16 packages for the minimum in devices size. Device operating temperature is -40 to 70°C to suit a wide range of environmental conditions.

FEATURES

- Provides bias for GaAs and HEMT FETs
- Drives up to three FETs
- Dynamic FET protection
- Drain current set by external resistor
- Regulated negative rail generator requires only 2 external capacitors
- Choice in drain voltage
- Wide supply voltage range
- QSOP surface mount package

APPLICATIONS

- Satellite receiver LNBS
- Private mobile radio (PMR)
- Cellular telephones
- Single in single out C Band LNB

ZNBG3000 ZNBG3001

ABSOLUTE MAXIMUM RATINGS

Supply Voltage	-0.6V to 15V	Power Dissipation ($T_{amb}=25^{\circ}\text{C}$)	
Supply Current	100mA	QSOP16	500mW
Drain Current (per FET) (set by R_{CAL1} and R_{CAL2})	0 to 15mA		
Output Current	100mA		
Operating Temperature	-30 to 70°C		
Storage Temperature	-40 to 85°C		

ELECTRICAL CHARACTERISTICS TEST CONDITIONS (Unless otherwise stated): $T_{amb}=25^{\circ}\text{C}, V_{CC}=5\text{V}, I_D=10\text{mA} (R_{CAL1}=33\text{k}\Omega)$

SYMBOL	PARAMETER	CONDITIONS	LIMITS			UNITS
			Min	Typ	Max	
V_{CC}	Supply Voltage		5		12	V
I_{CC}	Supply Current	I_{D1} to $I_{D3}=0$ I_{D1} to $I_{D3}=10\text{mA}$			10 40	mA mA
V_{SUB}	Substrate Voltage (Internally generated)	$I_{SUB}=0$ $I_{SUB}=-200\mu\text{A}$	-3.5	-2.8	-2 -2	V V
E_{ND} E_{NG}	Output Noise Drain Voltage Gate Voltage	$C_G=4.7\text{nF}, C_D=10\text{nF}$ $C_G=4.7\text{nF}, C_D=10\text{nF}$			0.02 0.005	Vpkpk Vpkpk
f_O	Oscillator Freq.		200	330	800	kHz

DRAIN CHARACTERISTICS

I_{DO}	Output Current Range	Set by R_{CAL1}	0		15	mA
I_D	Current		8	10	12	mA
ΔI_{DV} ΔI_{DT}	Current Change with V_{CC} with T_j	$V_{CC}=5$ to 12V $T_j=-30$ to +70°C		0.5 0.05		%/V %/°C
V_D	Voltage	ZNBG3000 ZNBG3001 I_{D1} to $I_{D3}=10\text{mA}$	2 1.8	2.2 2	2.4 2.2	V V
ΔV_{DV} ΔV_{DT}	Voltage Change with V_{CC} with T_j	$V_{CC}=5$ to 12V $T_j=-30$ to +70°C		0.5 50		%/V ppm

ZNBG3000
ZNBG3001

SYMBOL	PARAMETER	CONDITIONS	LIMITS			UNITS
			Min	Typ	Max	

GATE CHARACTERISTICS

I_{G0}	Output Current Range		-30		2000	μA
V_{OL}	Output Voltage					
	Output Low	I_{D1} to $I_{D3}=12\text{mA}$ I_{G1} to $I_{G3}=0$	-3.5		-2	V
V_{OH}	Output High	I_{D1} to $I_{D3}=12\text{mA}$ I_{G1} to $I_{G3}= -10\mu\text{A}$	-3.5		-2	V
	Output High	I_{D1} to $I_{D3}= 8\text{mA}$ I_{G1} to $I_{G3}= 0$	0.4		1	V

Notes:

1. The negative bias voltages specified are generated on-chip using an internal oscillator. Two external capacitors, C_{NB} and C_{SUB} , of 47nF are required for this purpose.

2. The characteristics are measured using an external reference resistors R_{CAL1} of value 33k Ω wired from pin R_{CAL1} to ground.

3. Noise voltage is not measured in production.

4. Noise voltage measurement is made with FETs and gate and drain capacitors in place on all outputs. C_G , 4.7nF, are connected between gate outputs and ground, C_D , 10nF, are connected between drain outputs and ground.

ZNBG3000 ZNBG3001

TYPICAL CHARACTERISTICS

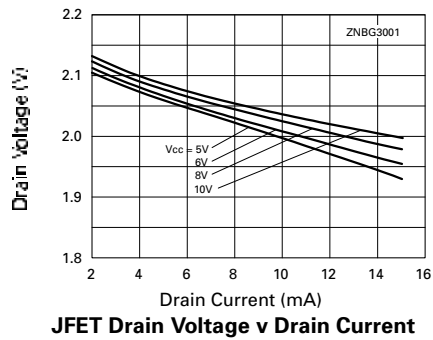
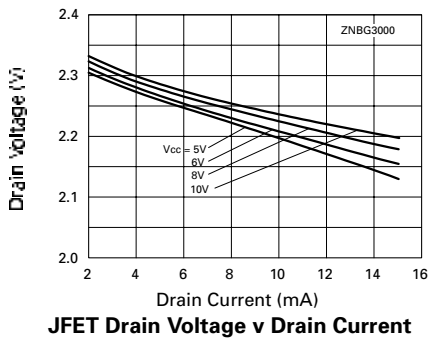
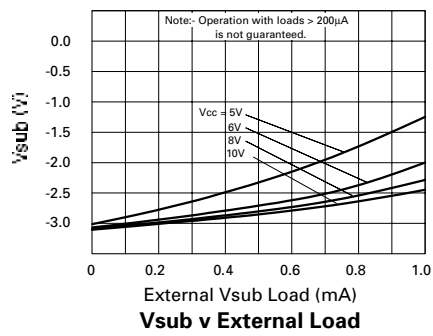
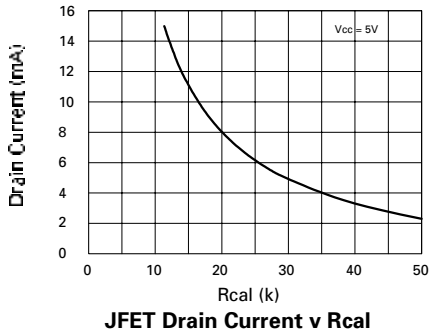

ZNBG3000 ZNBG3001

FUNCTIONAL DIAGRAM

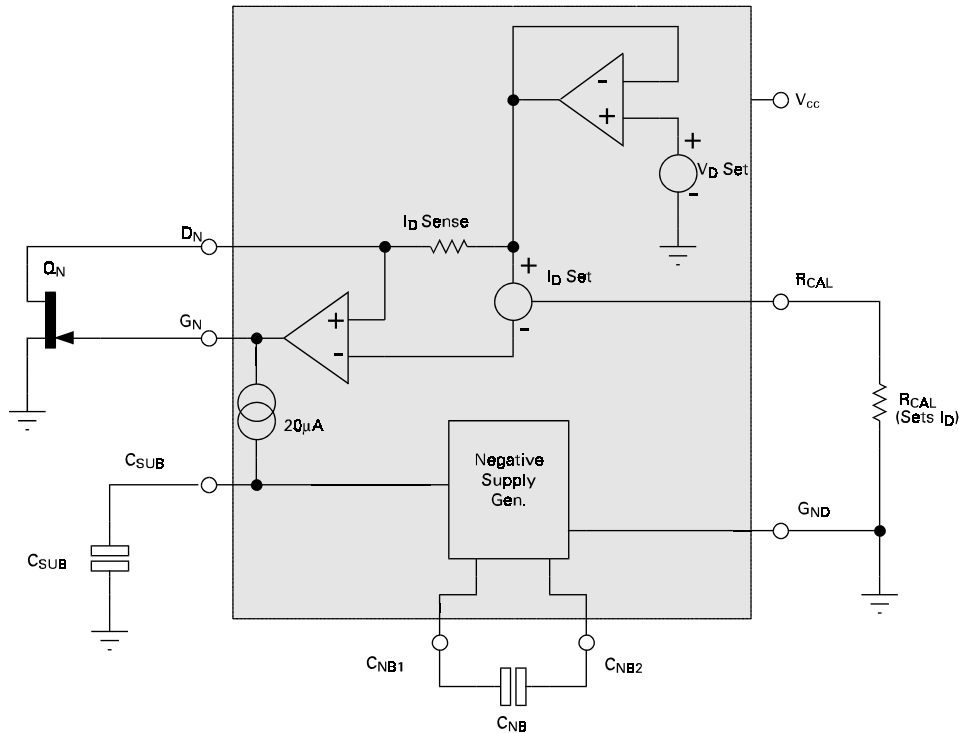

FUNCTIONAL DESCRIPTION

The ZNBG devices provide all the bias requirements for external FETs, including the generation of the negative supply required for gate biasing, from the single supply voltage.

The diagram above shows a single stage from the ZNBG series. The ZNBG3000/1 contains 3 such stages.

The drain voltage of the external FET Q_N is set by the ZNBG device to its normal operating voltage. This is determined by the on board V_D Set reference, for the ZNBG3000 this is nominally 2.2 volts whilst the ZNBG3001 provides nominally 2 volts.

The drain current taken by the FET is monitored by the low value resistor I_D Sense. The amplifier driving the gate of the FET adjusts the gate voltage of Q_N so that the drain current taken matches the current called for by an external resistor R_{CAL} . Both ZNBG devices have the facility to program different drain currents into selected FETs.

Since the FET is a depletion mode transistor, it is usually necessary to drive its gate negative with respect to ground to obtain the required drain current. To provide this capability powered from a single positive supply, the device includes a low current negative supply generator. This generator uses an internal oscillator and two external capacitors, C_{NB} and C_{SUB} .

ZNBG3000 ZNBG3001

TYPICAL APPLICATION CIRCUIT

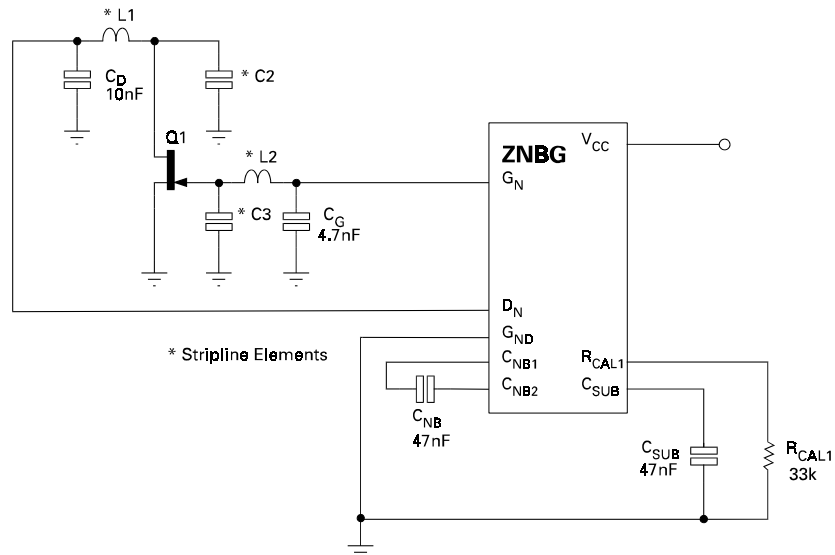

APPLICATIONS INFORMATION

The above is a partial application circuit for the ZNBG series showing all external components required for appropriate biasing. The bias circuits are unconditionally stable over the full temperature range with the associated FETs and gate and drain capacitors in circuit.

Capacitors C_D and C_G ensure that residual power supply and substrate generator noise is not allowed to affect other external circuits which may be sensitive to RF interference. They also serve to suppress any potential RF feedthrough between stages via the ZNBG device. These capacitors are required for all stages used. Values of 10nF and 4.7nF respectively are recommended however this is design dependent and any value between 1nF and 100nF could be used.

The capacitors C_{NB} and C_{SUB} are an integral part of the ZNBGs negative supply generator. The negative bias voltage is generated on-chip using an internal oscillator. The required value of capacitors C_{NB} and C_{SUB} is 47nF. This generator produces a low current supply of approximately -3 volts. Although this generator is intended purely to bias the external FETs, it can be used to power other external circuits via the C_{SUB} pin.

Resistor R_{CAL1} sets the drain current at which all external FETs are operated. If any bias control circuit is not required, its related drain and gate connections may be left open circuit without affecting the operation of the remaining bias circuits. If all FETs associated with a current setting resistor are omitted, the particular R_{CAL} should still be included. The supply current can be reduced, if required, by using a high value R_{CAL} resistor (e.g. 470k).

ZNBG3000 ZNBG3001

APPLICATIONS INFORMATION (Continued)

The ZNBG devices have been designed to protect the external FETs from adverse operating conditions. With a JFET connected to any bias circuit, the gate output voltage of the bias circuit can not exceed the range -3.5V to 0.7V, under any conditions including powerup and powerdown transients. Should the negative bias generator be shorted or overloaded so that the drain current of the external FETs can no longer be controlled, the drain supply to FETs is shut down to avoid damage to the FETs by excessive drain current.

The following diagram show the ZNBG3000/1 in typical LNB applications.

Single in/Single out C band LNB block diagram

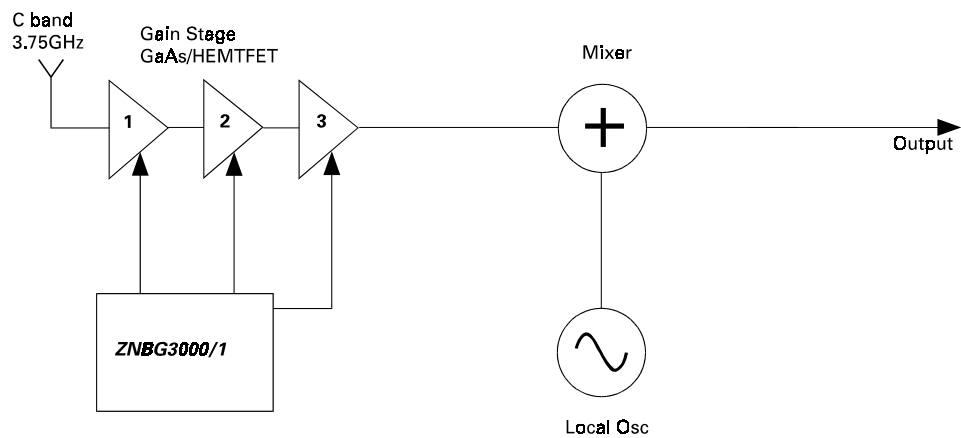

ZNBG3000 ZNBG3001

CONNECTION DIAGRAMS

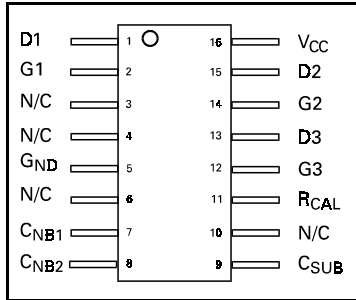

ORDERING INFORMATION

Part Number	Package	Part Mark
ZNBG3000Q16	QSOP16	ZNBG3000
ZNBG3001Q16	QSOP16	ZNBG3001

PACKAGE DIMENSIONS

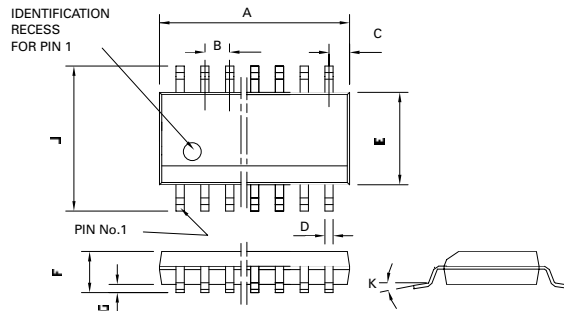

PIN	Millimetres		Inches	
	MIN	MAX	MIN	MAX
A	4.80	4.90	0.033	0.039
B	0.635		0.025 NOM	
C	0.177	0.267	0.007	0.011
D	0.20	0.30	0.008	0.012

E	3.81	3.99	0.15	0.157
F	1.35	1.75	0.053	0.069
G	0.10	0.25	0.004	0.01
J	5.79	6.20	0.228	0.244
K	0°	8°	0°	8°



Zetex plc.
Fields New Road, Chadderton, Oldham, OL9-8NP, United Kingdom.
Telephone: (44)161 622 4422 (Sales), (44)161 622 4444 (General Enquiries)
Fax: (44)161 622 4420

Zetex GmbH
Streitfeldstraße 19
D-81673 München
Germany
Telefon: (49) 89 45 49 49 0
Fax: (49) 89 45 49 49 49

Zetex Inc.
47 Mall Drive, Unit 4
Commack NY 11725
USA
Telephone: (516) 543-7100
Fax: (516) 864-7630

Zetex (Asia) Ltd.
3510 Metroplaza, Tower 2
Hing Fong Road,
Kwai Fong, Hong Kong
Telephone: (852) 26100 611
Fax: (852) 24250 494

These are supported by
agents and distributors in
major countries world-wide
©Zetex plc 1998

Internet: <http://www.zetex.com>

This publication is issued to provide outline information only which (unless agreed by the Company in writing) may not be used, applied or reproduced for any purpose or form part of any order or contract or be regarded as a representation relating to the products or services concerned. The Company reserves the right to alter without notice the specification, design, price or conditions of supply of any product or service.

ZNBG4000 ZNBG4001
ZNBG6000 ZNBG6001

ZNBG3000
ZNBG3001

PACKAGE DIMENSIONS

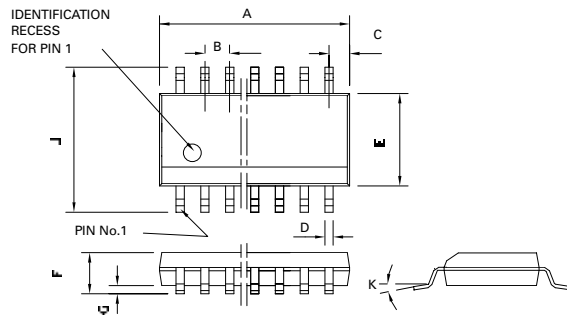



PIN	Millimetres		Inches	
	MIN	MAX	MIN	MAX
A	4.80	4.90	0.033	0.039
B	0.635		0.025 NOM	
C	0.177	0.267	0.007	0.011
D	0.20	0.30	0.008	0.012

E	3.81	3.99	0.15	0.157
F	1.35	1.75	0.053	0.069
G	0.10	0.25	0.004	0.01
J	5.79	6.20	0.228	0.244
K	0°	8°	0°	8°



Looking for pricing, stock, or lifecycle information?

Click below to explore more details on WIN SOURCE:

-  [View ZNBG3000Q16TC on WIN SOURCE](#)
-  [Diodes Incorporated Information](#)

Optimize Your Supply Chain with WIN SOURCE Solutions

-  Global Sourcing Solution
-  Obsolete Management
-  Cost Control Management
-  Shortage Management
-  Alternative Solution
-  Excess Inventory Management