



**THE DATASHEET OF
ZLNB2015JA16TC**



ZLNB2015
ADVANCED DBS DUAL CHANNEL VOLTAGE AND TONE DETECTOR

NEW PRODUCT

Summary

The ZLNB2015 is a dual channel polarisation (voltage) and band select (tone) detector IC, primarily for satellite applications such as Low Noise Blocks (LNBS) and satellite distribution systems. An optimised design provides a low supply current and a wide operating voltage whilst increasing performance and reliability. The ZLNB2015 offers excellent interference rejection with minimal application cost and packaged in the 3x3mm QFN it provides a very small solution.

Features

- Two high accuracy polarisation voltage detection meeting the most stringent market needs
- Two robust, interference tolerant 22kHz tone detection (without external signal filtering)
- “No Receiver” detect function for power saving and isolation control
- Low quiescent supply current, 2mA typical
- Wide operating supply voltage 3V to 8V
- Low external component count minimises application cost
- True and inverted outputs to support popular multiplexer ICs

Pin Assignments

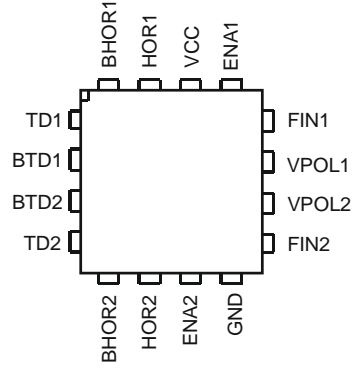

Top View

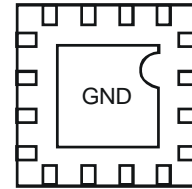

Bottom View

Application

- Twin Universal LNBS
- Quad Universal LNBS
- Multi Output LNBS
- Satellite Multi-Switches

Twin Universal LNB System Diagram

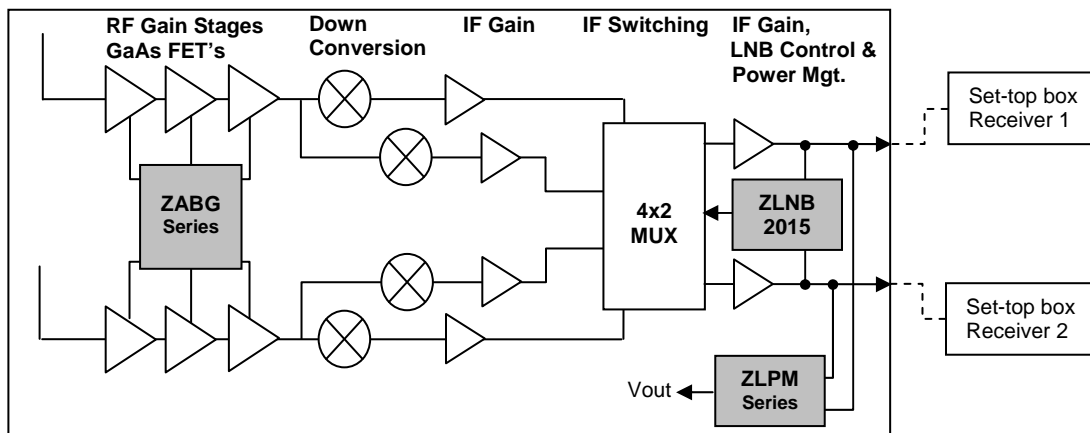

Device Description

The ZLNB2015 dual polarization and tone switch controller is one of a wide range of satellite receiver LNB support circuits available from Diodes Incorporated. It features two completely independent channels, each providing logic outputs to control LNB polarization selection, local oscillator selection and downfeed disable. It is intended use is in American voltage and tone controlled LNBs as well as high performance Twin, Quad and multiple feed Universal type LNBs, replacing many discrete components to save both manufacturing cost and PCB size whilst improving reliability.

The ZLNB2015 has been designed to be compatible in low power consumption LNBs so to improve efficiency it operates from a single supply of 3V to 8V and has a quiescent current typically of only 2mA. The quiescent current does not change significantly with load or logic state.

The two highly accurate polarization control inputs of the ZLNB2015 have a nominal threshold of 14.25V and to meet the required demanding needs of broadcasters they have a guaranteed threshold range of 14.0V to 14.5V. The threshold is temperature compensated to minimize drift and it also has a high rejection against the tone signal making the detector very accurate without the need of further external filtering. Each features a low and stable input current that enables transient protection to be achieved with the addition of only a single resistor per channel. Multi Feed LNBs can be called to operate with one or more of their controlling receivers powered down or disconnected, with attendant cable mismatch problems.

To ease design for this situation, each polarization input of the ZLNB2015 has a second threshold set at a nominal of 8V. An input voltage below this threshold indicates “receiver not present”, and switches the relevant Ena output low. This logic output can be used to disable the associated downfeed driver, eliminating any problems due to cable mismatch.

Universal LNB local oscillator selection is achieved by detection of a low level AC voltage superimposed on the polarization control voltage. To facilitate this function, the ZLNB2015 includes a separate tone detector for each channel. Control of detector bandwidth and sensitivity is provided using an external resistor and capacitor for each channel. The tone detector has been designed give excellent rejection of low frequency control signals and DiSEqC™ tone bursts. The ZLNB2015 has been specifically designed to minimize the solution cost whilst being flexible. The ZLNB2015 only requires two external components per channel to give full user control and functionality. The ZLNB2015 also includes complimentary outputs so that it can directly drive many multiplexer ICs without the need of inverters. Any unused outputs can be left open circuit without any effect to the remaining circuits operation polarization switch and tone detector outputs can directly drive TTL and CMOS logic, pin diodes, IF-amp supply switching and multiplexer ICs.

Maximum Ratings

Parameter	Rating	Unit
Supply Voltage	-0.6 to +10 Continuous	V
Supply Current	50	mA
V _{POL} 1, 2 Input Voltage (Note 1)	25	V
Power Dissipation	500	mW
Operating Temperature Range	-40 to +85	°C
Storage Temperature Range	-40 to +150	°C

Electrical Characteristics (at Tamb = 25°C, Vcc = 3.3V unless otherwise specified.)

Parameter	Conditions	Min.	Typ.	Max.	Unit
Operating Voltage Range		3.0		8.0	V
Supply Current	All outputs unloaded, any combination of inputs		2.0	3.0	mA

V _{POL} 1, 2 Inputs (Note 1)					
Input Current	V _{POL} 1,2 = 15V	32	42.5	53	uA
HOR Threshold	T _{AMB} = -40 to +85°C	14.0	14.25	14.5	V
ENA Threshold	T _{AMB} = -40 to +85°C	7.5	8.0	8.5	V
Switching Speed	HOR, BHOR and ENA outputs			1	ms

HOR1, 2 Outputs					
Voltage High	I _{LOAD} = -1mA, V _{POL} 1,2 = 14.5V	V _{CC} -0.5	V _{CC} -0.3	V _{CC}	V
Voltage Low	I _{LOAD} = 5mA, V _{POL} 1,2 = 14.0V	0	0.3	0.5	V

BHOR1, 2 Outputs					
Voltage High	I _{LOAD} = -1mA, V _{POL} 1,2 = 14.0V	V _{CC} -0.5	V _{CC} -0.3	V _{CC}	V
Voltage Low	I _{LOAD} = 5mA, V _{POL} 1,2 = 14.5V	0	0.3	0.5	V

ENA1, 2 Outputs					
Voltage High	I _{LOAD} = -1mA, V _{POL} 1,2 = 8.5V	V _{CC} -0.5	V _{CC} -0.3	V _{CC}	V
Voltage Low	I _{LOAD} = 5mA, V _{POL} 1,2 = 7.5V	0	0.3	0.5	V

FIN 1, 2 Inputs (Using Test Circuit 1)					
Bias Voltage	I _{FIN} = 0	1.25	1.74	2.25	V
Input Impedance	V _{FIN} = 100mV _{P/P}		40		kΩ
Amplifier Gain	V _{FIN} = 100mV _{P/P}		50		
Voltage Threshold		100	150	300	mV
Switching Delay	TD Outputs		3	10	ms

TD1, 2 Outputs (Using Test Circuit 1)					
Voltage High	I _{LOAD} = -1mA, Tone Enabled	V _{CC} -0.5	V _{CC} -0.3	V _{CC}	V
Voltage Low	I _{LOAD} = 5mA, Tone Disabled	0	0.3	0.5	V

BTD1, 2 Outputs (Using Test Circuit 1)					
Voltage High	I _{LOAD} = -1mA, Tone Disabled	V _{CC} -0.5	V _{CC} -0.3	V _{CC}	V
Voltage Low	I _{LOAD} = 5mA, Tone Enabled	0	0.3	0.5	V

Notes: 1. V_{POL} stimulus applied via 6.8k resistors. All levels measured on the input to these resistors.
2. ESD sensitive, handling precautions are recommended.

Test Circuit

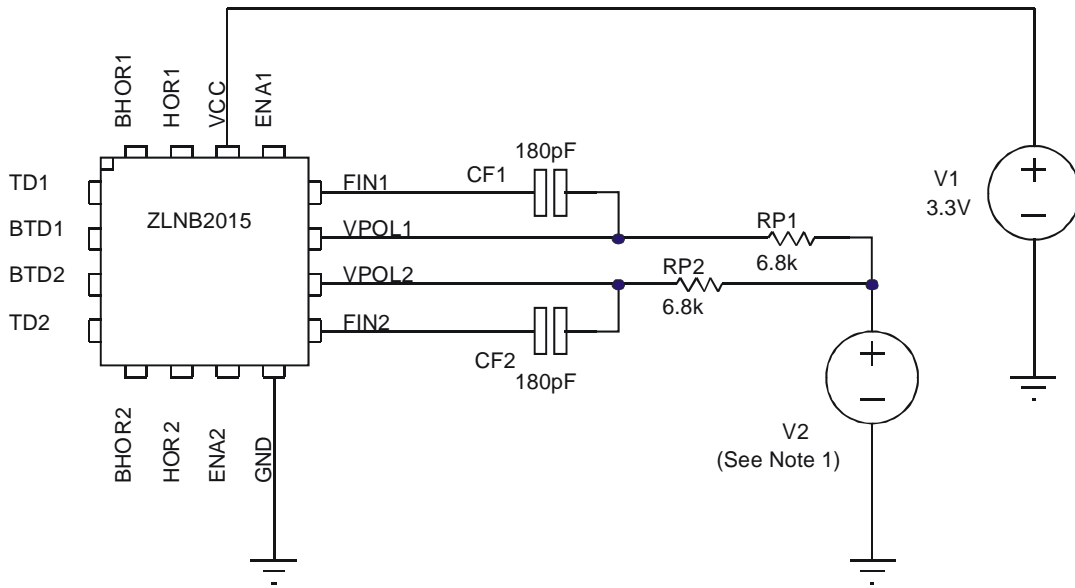

Note 1: V2 Characteristics

- Type:- AC source
- Frequency:- 22kHz
- Voltage:- 300mVp/p Enabled
Zero Disabled

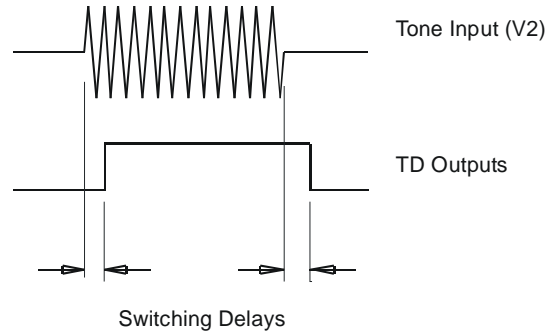

NEW PRODUCT

Applications Information

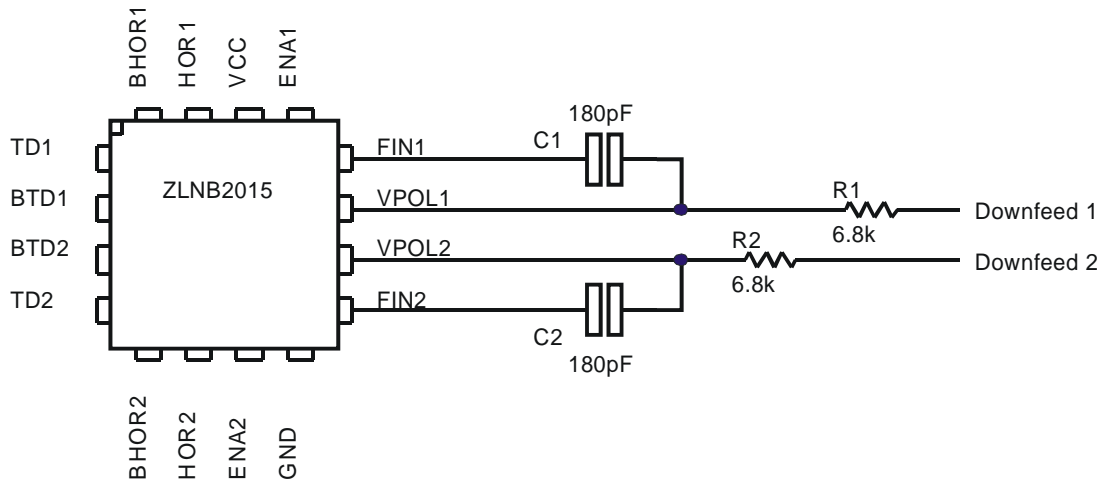

NEW PRODUCT

Above is a partial applications circuit for the ZLNB2015 showing all external components needed for a typical twin LNB design. The inputs Vpol1 and Vpol2 are designed to be wired to the power inputs of the LNB via ESD protection resistors (6.8k). These inputs control the HOR1/2, BHOR1/2 and ENA1/2 logic outputs. The HOR outputs will be low when their corresponding Vpol input is at or below 14V and high when Vpol is at or above 14.5V. The BHOR outputs give inverted versions of their related HOR outputs. The HOR/BHOR outputs are intended to activate polarisation selection circuitry within an LNB, under control of the LNB supply voltage. The ENA1/2 outputs are set high when their corresponding Vpol input is at or above 8.5V and low when Vpol is at or below 7.5V. These logic outputs can be used to disable any LNB RF output connected to a receiver (STB) that has been powered down or disconnected (and hence not providing correct cable matching).

The ZLNB2015 includes circuitry necessary to detect the presence of a 22kHz tone modulated on either of two supply inputs to the LNB. These detectors control the TD1/2 and BTD1/2 outputs. The TD outputs are set high on detection of a valid tone on their corresponding LNB input and low in the absence of a tone. The BTD outputs give an inverted version of their corresponding TD outputs. The main elements of each tone detector are an amplifier, a band-pass filter, a rectifier/smoothen and a comparator. User control is given over the gain of the amplifier and the lower frequency limit of the filter, using an external resistor and capacitor. (The ESD protection resistor noted above can be used to set amplifier gain, hence requiring only one component for both functions.) The higher frequency limit of the filter is set internally to block signals above 100kHz. The comparator circuit utilises no external components.

The HOR, BHOR, TD, BTD and ENA outputs are designed to be compatible with LSTTL, CMOS and common MIMIC multiplexer loads. Any input or output that is not required can be left open circuit.

Output Truth Table

The ZLNB2015 includes two independent channels, each containing a voltage detector and tone detector. The following truth table applies to each channel.

Tone	Vpol	TD	BTD	HOR	BHOR	ENA
Off	14V	Low	High	Low	High	High
Off	14.5V	Low	High	High	Low	High
On	14V	High	Low	Low	High	High
On	14.5V	High	Low	High	Low	High
-	<7.5V	-	-	Low	High	Low

Package Outline Dimensions

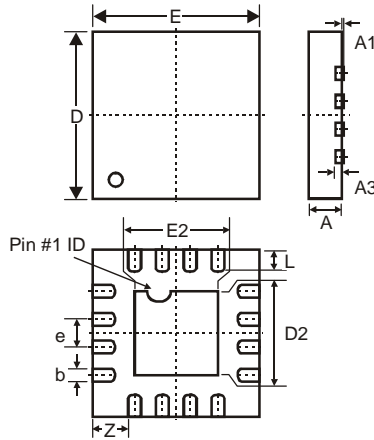

QFN16 3x3		
Dim	Min	Max
A	0.55	0.65
A1	0.00	0.05
A3	0.15 Typ	
b	0.18	0.28
D	2.95	3.05
D2	1.40	1.60
e	0.50 BSC	
E	2.95	3.05
E2	1.40	1.60
L	0.35	0.45
Z	0.625 Typ	
All Dimensions in mm		

Note: Controlling dimensions are in millimeters. Approximate dimensions are provided in inches.
The package appearance may vary as shown, for further details please contact your local Diodes sales office.

Ordering Information (Note x)

Device	Package	Reel Size (inches)	Tape Width (mm)	Quantity (per reel)
ZLNB2015JA16TC	QFN1633	13	8	3000

NEW PRODUCT

IMPORTANT NOTICE

DIODES INCORPORATED MAKES NO WARRANTY OF ANY KIND, EXPRESS OR IMPLIED, WITH REGARDS TO THIS DOCUMENT, INCLUDING, BUT NOT LIMITED TO, THE IMPLIED WARRANTIES OF MERCHANTABILITY AND FITNESS FOR A PARTICULAR PURPOSE (AND THEIR EQUIVALENTS UNDER THE LAWS OF ANY JURISDICTION).

Diodes Incorporated and its subsidiaries reserve the right to make modifications, enhancements, improvements, corrections or other changes without further notice to this document and any product described herein. Diodes Incorporated does not assume any liability arising out of the application or use of this document or any product described herein; neither does Diodes Incorporated convey any license under its patent or trademark rights, nor the rights of others. Any Customer or user of this document or products described herein in such applications shall assume all risks of such use and will agree to hold Diodes Incorporated and all the companies whose products are represented on Diodes Incorporated website, harmless against all damages.

Diodes Incorporated does not warrant or accept any liability whatsoever in respect of any products purchased through unauthorized sales channel. Should Customers purchase or use Diodes Incorporated products for any unintended or unauthorized application, Customers shall indemnify and hold Diodes Incorporated and its representatives harmless against all claims, damages, expenses, and attorney fees arising out of, directly or indirectly, any claim of personal injury or death associated with such unintended or unauthorized application.

Products described herein may be covered by one or more United States, international or foreign patents pending. Product names and markings noted herein may also be covered by one or more United States, international or foreign trademarks.

LIFE SUPPORT

Diodes Incorporated products are specifically not authorized for use as critical components in life support devices or systems without the express written approval of the Chief Executive Officer of Diodes Incorporated. As used herein:

- A. Life support devices or systems are devices or systems which:
 - 1. are intended to implant into the body, or
 - 2. support or sustain life and whose failure to perform when properly used in accordance with instructions for use provided in the labeling can be reasonably expected to result in significant injury to the user.
- B. A critical component is any component in a life support device or system whose failure to perform can be reasonably expected to cause the failure of the life support device or to affect its safety or effectiveness.

Customers represent that they have all necessary expertise in the safety and regulatory ramifications of their life support devices or systems, and acknowledge and agree that they are solely responsible for all legal, regulatory and safety-related requirements concerning their products and any use of Diodes Incorporated products in such safety-critical, life support devices or systems, notwithstanding any devices- or systems-related information or support that may be provided by Diodes Incorporated. Further, Customers must fully indemnify Diodes Incorporated and its representatives against any damages arising out of the use of Diodes Incorporated products in such safety-critical, life support devices or systems.

Copyright © 2010, Diodes Incorporated

www.diodes.com

Looking for pricing, stock, or lifecycle information?

Click below to explore more details on WIN SOURCE:

 [View ZLNB2015JA16TC on WIN SOURCE](#)

 [Diodes Incorporated Information](#)

Optimize Your Supply Chain with WIN SOURCE Solutions

-  Global Sourcing Solution
-  Obsolete Management
-  Cost Control Management
-  Shortage Management
-  Alternative Solution
-  Excess Inventory Management