



**THE DATASHEET OF  
ZAMP002H6TA**



# ZAMP002

---

## 800-2500MHz MMIC WIDEBAND AMPLIFIER

### Medium Power, 22dB Gain, Wide Dynamic Range

---

#### DESCRIPTION

The ZAMP002 is a low current high performance RF amplifier designed for L band and IF applications. Although the ZAMP002 has been designed primarily for DBS applications the ZAMP002 is capable of extending to frequencies of 2.5GHz so it has a good fit with various applications. An additional benefit of the ZAMP002 is its rising gain characteristic, this has been designed to counteract the gain losses found at the higher frequencies. The ZAMP002 has been optimized to an input impedance of 50ohms while the output impedance has been designed for optimum match to an impedance of 75ohms. Packaged in a small SC70-6 with the minimum number of external bias components required it is the ideal solution for space and current limited applications.

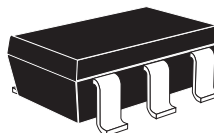

SC70-6

#### FEATURES

- L and IF frequency band
- Low noise
- Low current consumption 21mA typical
- Gain 22dB typical
- Rising gain across band
- IP3 22dBm @ 1GHz
- 4.5 to 5.5V supply voltage
- SC70-6 SMD package

#### APPLICATIONS

- Satellite LNB receivers
- RF buffers - tuners
- SMR (Special Mobile Radio)
- RLAN/WLAN
- General purpose

#### CONNECTION DIAGRAM

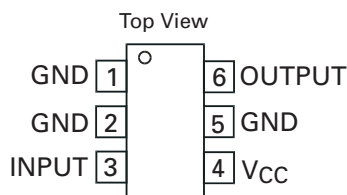

#### ORDERING INFORMATION

DEVICE	REEL SIZE (inches)	QUANTITY PER REEL	DEVICE MARKING
ZAMP002H6TA	7"	3000 units	ZB02
ZAMP002H6TC	13"	10000 units	ZB02

# ZAMP002

## ABSOLUTE MAXIMUM RATINGS

Supply Voltage	7V
Supply Current	30mA
Operating Temperature	-40 to 85°C
Storage Temperature	-50 to 125°C

## ELECTRICAL CHARACTERISTICS

Test Conditions (unless otherwise stated):  $V_{CC} = 5V$ ,  $T_{amb} = 25^{\circ}C$ ,  $Z_o = 50\Omega$ .

SYMBOL	PARAMETER	CONDITIONS	MIN	TYP.	MAX	UNITS
F <sub>O</sub>	Operating Frequency		800		2500	MHz
V <sub>CC</sub>	Supply Voltage		4.5	5	5.5	V
I <sub>CC</sub>	Supply Current			21	24	mA
G <sub>p</sub>	Power Gain	F = 950 MHz	21	22		dB
		F = 1550 MHz		22		dB
		F = 2150 MHz		23	25	dB
NF	Noise Figure	F = 950 MHz		6		dB
		F = 1550 MHz		6.5		dB
		F = 2150 MHz		7		dB
IP <sub>3</sub>	3rd Order Intercept Point	F = 950 MHz	18	22		dBm
		F = 2150 MHz		17		dBm
P <sub>1dB</sub>	1dB Gain Compression	F = 950 to 2150 MHz		7		dBm
RL <sub>IN</sub>	Input Return Loss	F = 950 MHz		16		dB
		F = 2150 MHz		17		dB
RL <sub>OUT</sub>	Output Return Loss	F = 950 MHz		10		dB
		F = 2150 MHz		9		dB
Risol	Reverse Isolation	F = 950 MHz		30		dB
		F = 2150 MHz		33		dB

# ZAMP002

## TYPICAL CHARACTERISTICS

Test Conditions (unless otherwise stated):  $V_{CC} = 5V$ ,  $T_{amb} = 25^{\circ}C$ ,  $Z_o = 50\Omega$ .

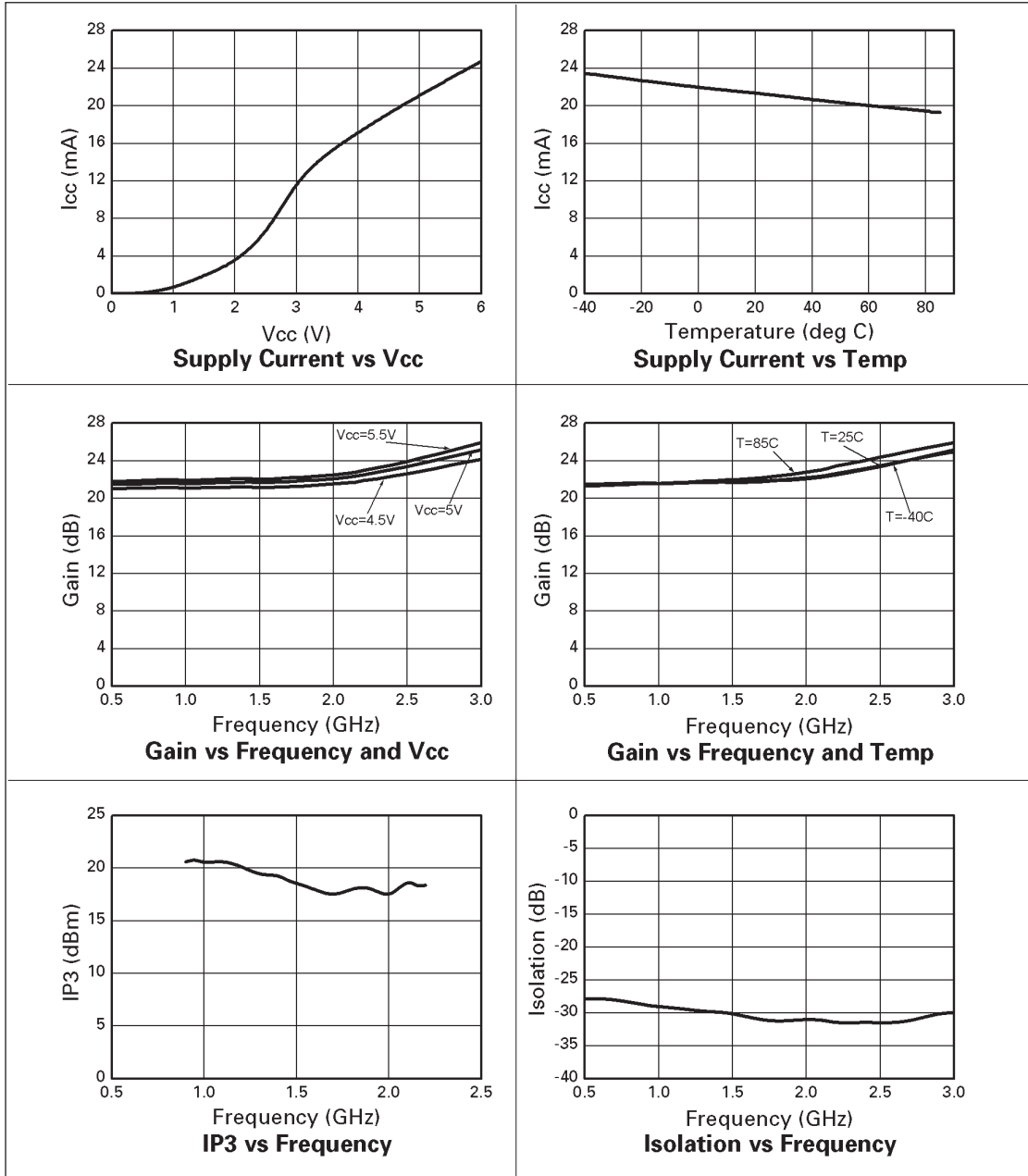

# ZAMP002

## TYPICAL CHARACTERISTICS

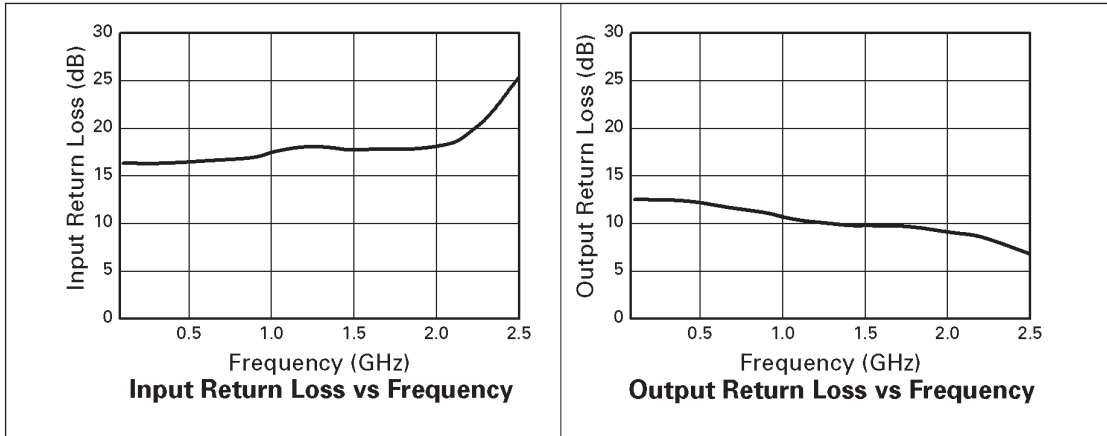

# ZAMP002

## TEST CIRCUIT

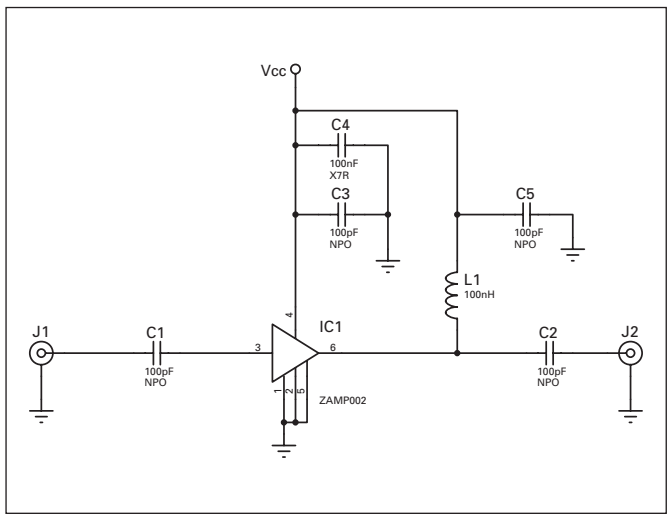

## CIRCUIT COMPONENTS LIST

Circuit Ref.	Description	Value	Type
C1,C2,C3, C5	Chip ceramic capacitor	100 pF	Murata GRH708 series, size 0805
C4	Chip ceramic capacitor	100 nF	X7R, size 0805
L1	Chip inductor	100 nH	Murata LQW18ANR10G00D, size 0805
IC1	ZAMP002		Wideband Amplifier, SC70-6

# ZAMP002

## TEST CIRCUIT LAYOUT

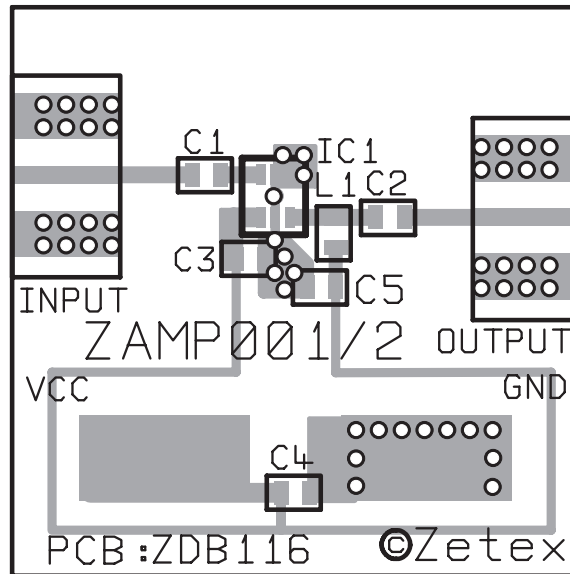

### APPLICATION NOTES

The ZAMP002 is a wideband RFIC amplifier designed for use primarily in DBS applications. The amplifier is designed to provide a 50 Ohm input and 75 Ohm output and thus requires no additional matching components. The input and output signal connections each require a DC blocking capacitor (C1 and C2). A suitable value for these capacitors is 100pF for the 950MHz to 2150MHz frequency range. For other frequency ranges the value of the capacitor should be such that its reactance at the lowest operating frequency is small when compared to 50 ohms (or 75 Ohms for the output). Supply de-coupling is also recommended and should take the form of a suitable 100pF capacitor, C3, for the 950MHz to 2150MHz frequency range. The 100pF capacitor should be mounted as close to the Vcc pin of the amplifier as is physically possible. An additional low frequency de-coupling capacitor, C4, with a value of 100nF is also advised. The ZAMP002 requires a RF choke inductor, L1, providing DC bias to the output line. A value of 100nH is recommended for the 950 MHz to 2150MHz frequency range.

An example layout for a test board for the ZAMP series can be seen above. This was designed for an FR4 board 1 x 1 inch, 0.016 inch thick with a copper thickness of 35 microns. Edge mounted SMA connectors were used for the RF signals.

Notes



# ZAMP002

## PACKAGE DIMENSIONS SC706

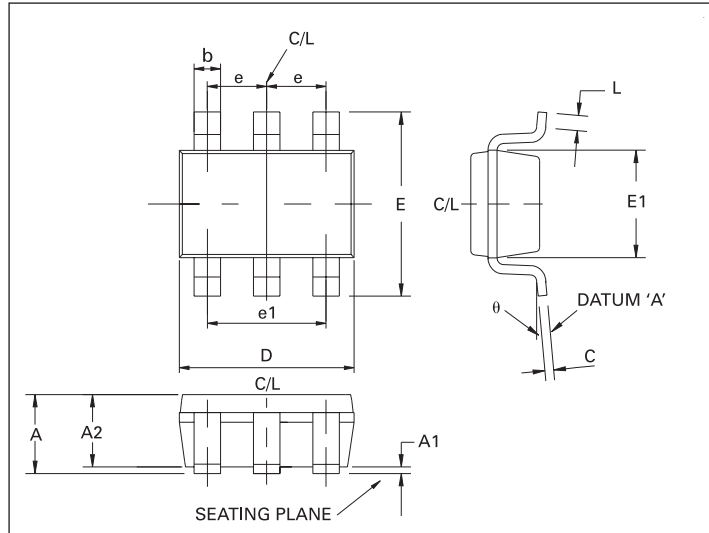

## PACKAGE DIMENSIONS

DIM	MILLIMETRES		DIM	MILLIMETRES	
	MIN	MAX		MIN	MAX
A	—	1.00	E	2.10 BSC	
A1	—	0.10	E1	1.25	1.35
A2	0.70	0.90	e	0.65 BSC	
b	0.15	0.30	e1	1.30 BSC	
C	0.08	0.25	L	0.26	0.46
D	2.00 BSC		θ	0°	8°

© Zetex plc 2003

### Europe

Zetex plc  
Fields New Road  
Chadderton  
Oldham, OL9 8NP  
United Kingdom  
Telephone (44) 161 622 4444  
Fax: (44) 161 622 4446  
hq@zetex.com

Zetex GmbH  
Streitfeldstraße 19  
D-81673 München  
Germany  
Telefon: (49) 89 45 49 49 0  
Fax: (49) 89 45 49 49 49  
europe.sales@zetex.com

### Americas

Zetex Inc  
700 Veterans Memorial Hwy  
Hauppauge, NY 11788  
USA  
Telephone: (1) 631 360 2222  
Fax: (1) 631 360 8222  
usa.sales@zetex.com

### Asia Pacific

Zetex (Asia) Ltd  
3701-04 Metroplaza Tower 1  
Hing Fong Road  
Kwai Fong  
Hong Kong  
Telephone: (852) 26100 611  
Fax: (852) 24250 494  
asia.sales@zetex.com

These offices are supported by agents and distributors in major countries world-wide.

This publication is issued to provide outline information only which (unless agreed by the Company in writing) may not be used, applied or reproduced for any purpose or form part of any order or contract or be regarded as a representation relating to the products or services concerned. The Company reserves the right to alter without notice the specification, design, price or conditions of supply of any product or service.

For the latest product information, log on to [www.zetex.com](http://www.zetex.com)



ISSUE 2 - MARCH 2003

## Looking for pricing, stock, or lifecycle information?

Click below to explore more details on WIN SOURCE:

 [View ZAMP002H6TA on WIN SOURCE](#)

 [Diodes Incorporated](#) Information

## Optimize Your Supply Chain with WIN SOURCE Solutions

-  Global Sourcing Solution
-  Obsolete Management
-  Cost Control Management
-  Shortage Management
-  Alternative Solution
-  Excess Inventory Management