



**THE DATASHEET OF  
Z8FMC08100AKEG**





# Z8FMC16100 Series

## Product Brief

PB016607-0308



### Product Block Diagram

12-Bit PWM Module for Motor Control	16-Bit Timer Capture/Compare/PWM	Operational Amplifier
Up to 16 KB Flash	20 MHz eZ8™ CPU	8-Channel 10-Bit ADC
512 B SRAM		VBO/POR and Reset Control
I <sup>2</sup> C, SPI, and UART with LIN		
Watchdog Timer	Single-Pin Debugger	Internal Precision Oscillator
Comparator		Interrupt Controller
17 General Purpose I/O Pins		

### Overview

Zilog's Z8FMC16100 Series Flash microcontrollers, a part of the Z8 Encore! MC™ family of motor control devices, are based on Zilog's advanced eZ8™ 8-bit CPU core. Optimized for motor control applications, these devices support the control of Single and Multiphase variable-speed motors. Target applications are large appliances, small appliances, HVAC, automotive, power tools, and personal care devices.

Z8FMC16100 Series Flash MCUs feature a flexible pulse width modulator (PWM) module with three complementary pairs or six independent PWM outputs supporting dead-band operation and fault protection trip input. These features provide multiphase control capability for a variety of motor types and ensure safe operation of the motor by

providing Pulse-by-Pulse or latched fast shutdown of the PWM pins during fault condition.

Z8FMC16100 Series MCU features up to eight single-ended channels of 10-bit analog-to-digital conversion, with a sample and hold circuit. It also features one operational amplifier for current sampling and one comparator for over-current limiting or shutdown.

A high-speed analog-to-digital converter (ADC) enables voltage, current, and back-EMF sensing, while dual-edge interrupts and a 16-bit timer provide a Hall-effect sensor interface.

A full-duplex 9-bit UART provides serial, asynchronous communication and supports the local interconnect network (LIN) serial communications protocol. The LIN bus is a cost-efficient Single Master, Multiple Slave organization that supports speed up to 20 kbps.

Included in its rich-set of peripherals are other features such as: one additional 16-bit timer with Capture/Compare/PWM capability, SPI or I<sup>2</sup>C Master/Slave for serial communication, and an internal precision oscillator (IPO).

The single-pin debugger and programming interface simplifies code development and allows easy in-circuit programming.

### Z8FMC16100 Series MCU Features

The features of Z8FMC16100 Series MCU include:

- 20 MHz eZ8 CPU core
- Up to 16 KB Flash program memory
- 512 B register SRAM

- Fast 8-channel 10-bit ADC for current sampling and back-EMF detection
- 12-bit PWM module with three complementary pairs or six independent PWM outputs with dead-band generation and fault trip input
- One 16-bit timer with Capture/Compare/PWM capability
- One analog comparator for current limiting or over current shutdown
- One operational amplifier provides current level-shifting and amplification for ADC current sampling
- I<sup>2</sup>C in MASTER, SLAVE, and MULTIMASTER modes
- SPI controller
- UART with LIN interface
- Internal Precision Oscillator (IPO)
- Oscillator supports either internal IPO or external crystals and ceramic resonators
- 17 General-Purpose I/O pins (GPIO)
- Voltage Brownout/Power-On Reset (VBO/POR)
- Watchdog Timer (WDT) with internal RC oscillator
- Single-Pin On-Chip Debugger
- In-circuit serial programming
- Operating at 2.7 V to 3.6 V
- 32-pin QFN and LQFP packages
- Lead-free packaging option
- Standard and extended temperature ranges: 0 °C to 70 °C (standard) and –40 °C to +105 °C (extended)
- Up to 20 interrupts with configurable priority

## eZ8™ CPU Features

The features of eZ8 CPU include:

- New instructions for improved performance including BIT, BSWAP, BTJ, CPC, LDC, LDCI, LEA, MULT, and SRL
- Compatible with existing Z8® code
- Up to 10 MIPS operation
- C-Compiler friendly
- 2 to 9 clock cycles per instruction

## Architecture

Figure 1 displays the Z8FMC16100 Series MCU block diagram.

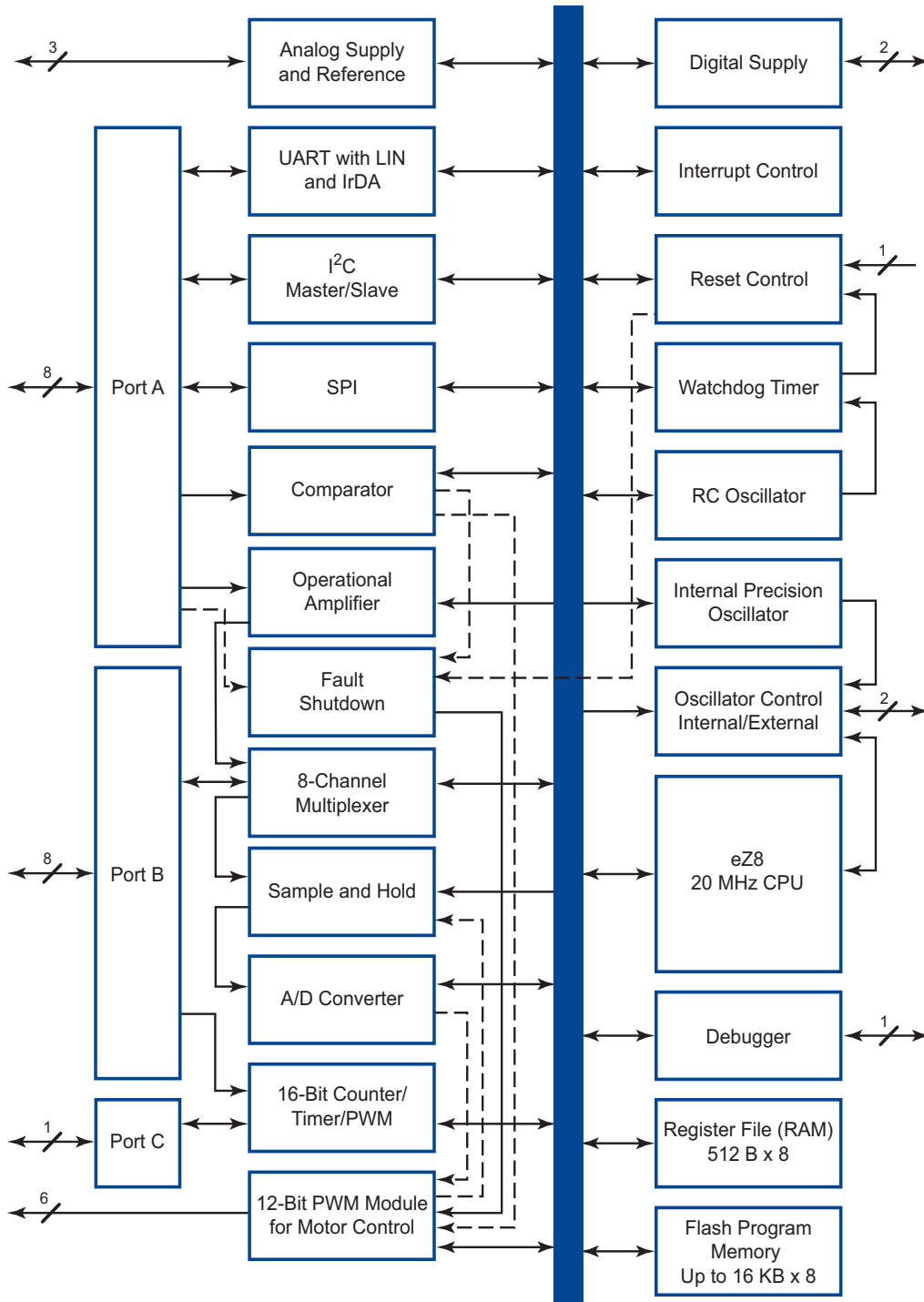

Figure 1. Z8FMC16100 Series MCU Block Diagram

## Ordering Information

Table 1 provides the basic features available for each device within the Z8FMC16100 Series product line. Table 2 provides ordering information for the Z8FMC16100 Series products, by part number. See [Part Number Suffix Designations](#) on page 6 for product numbering details.

**Table 1. Z8FMC16100 Series Part Selection Guide**

Product Feature	Z8FMC16100	Z8FMC08100	Z8FMC04100
Flash (KB)	16	8	4
SRAM (B)	512	512	512
General-Purpose I/O	17	17	17
Motor Control PWM Channels	6	6	6
ADC Inputs	8	8	8
Operational Amplifier	Yes	Yes	Yes
Comparator	Yes	Yes	Yes
16-bit Standard Timers with Capture, Compare, PWM	Yes	Yes	Yes
UART with support for LIN and IrDA	Yes	Yes	Yes
I <sup>2</sup> C	Yes	Yes	Yes
SPI Controller	Yes	Yes	Yes
Watchdog Timer	Yes	Yes	Yes
5.5296 MHz Internal Precision Oscillator	Yes	Yes	Yes

Each of the parts listed in Table 2 is available in a lead-free package that conforms to responsible environmental standards. For more information regarding ordering, contact your local Zilog<sup>®</sup> sales office. Zilog web site, [www.zilog.com](http://www.zilog.com), lists all regional offices and provides additional Z8FMC16100 Series product information.



Table 2. Ordering Information for the Z8FMC16100 Series Products\*

Part Number	Flash KB (Bytes)	SRAM Bytes	GPIO	Max. Speed (MHz)	I <sup>2</sup> C/SPI	Trimmed IPO	Package	Temp (°C)
<b>Z8FMC16100 with 16 KB Flash and 512 B SRAM</b>								
Z8FMC16100QKSG	16	512	17	20	I <sup>2</sup> C/SPI	Y	QFN-32	0 to +70
Z8FMC16100QKEG	(16,384)							-40 to +105
Z8FMC16100AKSG	16	512	17	20	I <sup>2</sup> C/SPI	Y	LQFP-32	0 to +70
Z8FMC16100AKEG	(16,384)							-40 to +105
<b>Z8FMC08100 with 8 KB Flash and 512B SRAM</b>								
Z8FMC08100QKSG	8	512	17	20	I <sup>2</sup> C/SPI	Y	QFN-32	0 to +70
Z8FMC08100QKEG	(8,192)							-40 to +105
Z8FMC08100AKSG	8	512	17	20	I <sup>2</sup> C/SPI	Y	LQFP-32	0 to +70
Z8FMC08100AKEG	(8,192)							-40 to +105
<b>Z8FMC04100 with 4 KB Flash and 512B SRAM</b>								
Z8FMC04100QKSG	4	512	17	20	I <sup>2</sup> C/SPI	Y	QFN-32	0 to +70
Z8FMC04100QKEG	(4,096)							-40 to +105
Z8FMC04100AKSG	4	512	17	20	I <sup>2</sup> C/SPI	Y	LQFP-32	0 to +70
Z8FMC04100AKEG	(4,096)							-40 to +105
<b>Z8FMC16100 Series Development Tools</b>								
Z8FMC160100KITG	Z8FMC16100 Series Development Kit							
Z8FMC161000ZEM	Z8 Encore! Z8FMC16100 Series In-Circuit Emulator Development Tool							
ZUSBOPTSC01ZACG	USB Opto-isolated Smart Cable Accessory Kit							
<b>Z8FMC16100 Series Development Tools</b>								
*Factory programming of the devices in this table are available upon request from Zilog®.								



## Part Number Suffix Designations

Zilog part numbers consist of a number of components. This section describes an example part number, Z8FMC16100QKSG, to indicate each component's description.

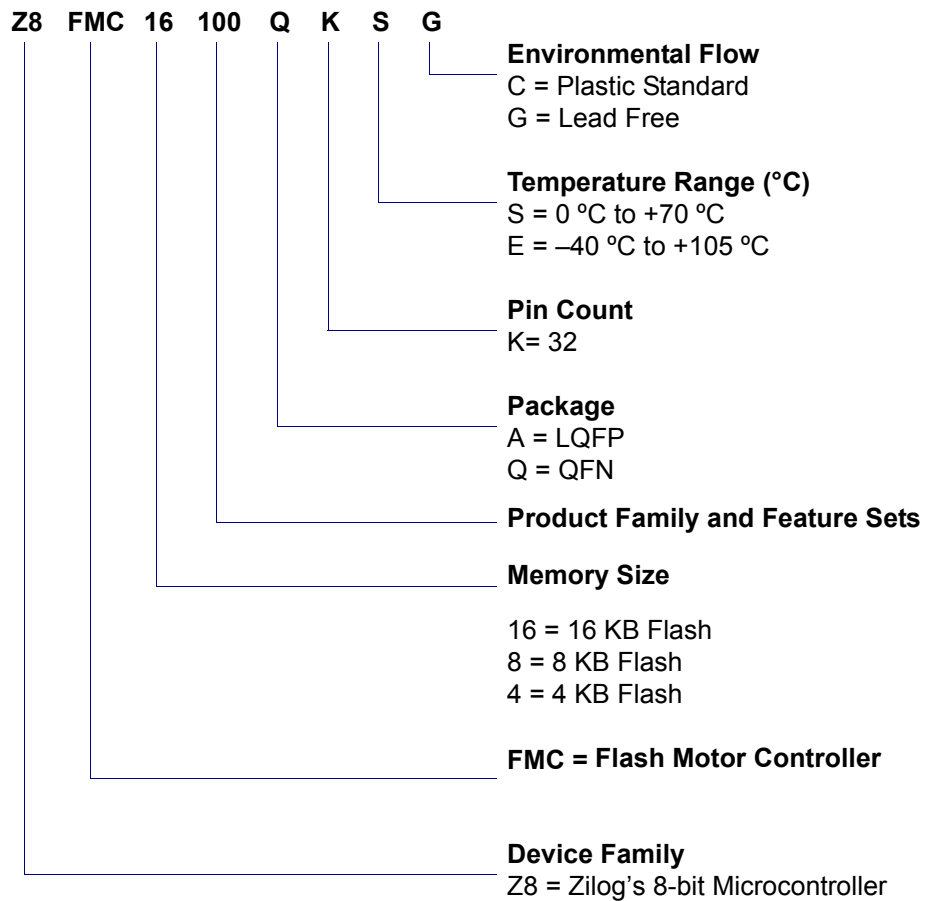



**Warning:** DO NOT USE IN LIFE SUPPORT

### **LIFE SUPPORT POLICY**

ZILOG'S PRODUCTS ARE NOT AUTHORIZED FOR USE AS CRITICAL COMPONENTS IN LIFE SUPPORT DEVICES OR SYSTEMS WITHOUT THE EXPRESS PRIOR WRITTEN APPROVAL OF THE PRESIDENT AND GENERAL COUNSEL OF ZILOG CORPORATION.

### **As used herein**

Life support devices or systems are devices which (a) are intended for surgical implant into the body, or (b) support or sustain life and whose failure to perform when properly used in accordance with instructions for use provided in the labeling can be reasonably expected to result in a significant injury to the user. A critical component is any component in a life support device or system whose failure to perform can be reasonably expected to cause the failure of the life support device or system or to affect its safety or effectiveness.

### **Document Disclaimer**

©2008 by Zilog, Inc. All rights reserved. Information in this publication concerning the devices, applications, or technology described is intended to suggest possible uses and may be superseded. ZILOG, INC. DOES NOT ASSUME LIABILITY FOR OR PROVIDE A REPRESENTATION OF ACCURACY OF THE INFORMATION, DEVICES, OR TECHNOLOGY DESCRIBED IN THIS DOCUMENT. ZILOG ALSO DOES NOT ASSUME LIABILITY FOR INTELLECTUAL PROPERTY INFRINGEMENT RELATED IN ANY MANNER TO USE OF INFORMATION, DEVICES, OR TECHNOLOGY DESCRIBED HEREIN OR OTHERWISE. The information contained within this document has been verified according to the general principles of electrical and mechanical engineering.

Z8, Z8 Encore!, eZ8, and Z8 Encore! MC are trademarks or registered trademarks of Zilog, Inc. All other product or service names are the property of their respective owners.

## Looking for pricing, stock, or lifecycle information?

Click below to explore more details on WIN SOURCE:

 [View Z8FMC08100AKEG on WIN SOURCE](#)

 [Zilog Information](#)

## Optimize Your Supply Chain with WIN SOURCE Solutions

-  Global Sourcing Solution
-  Obsolete Management
-  Cost Control Management
-  Shortage Management
-  Alternative Solution
-  Excess Inventory Management