



**THE DATASHEET OF
Z53C8003VSC**





Z53C80

***Small Computer System
Interface (SCSI)***

Product Specification

PS010801-0601



This publication is subject to replacement by a later edition. To determine whether a later edition exists, or to request copies of publications, contact:

ZiLOG Worldwide Headquarters

910 E. Hamilton Avenue
Campbell, CA 95008
Telephone: 408.558.8500
Fax: 408.558.8300
www.ZiLOG.com

Windows is a registered trademark of Microsoft Corporation.

Document Disclaimer

©2001 by ZiLOG, Inc. All rights reserved. Information in this publication concerning the devices, applications, or technology described is intended to suggest possible uses and may be superseded. ZiLOG, INC. DOES NOT ASSUME LIABILITY FOR OR PROVIDE A REPRESENTATION OF ACCURACY OF THE INFORMATION, DEVICES, OR TECHNOLOGY DESCRIBED IN THIS DOCUMENT. ZiLOG ALSO DOES NOT ASSUME LIABILITY FOR INTELLECTUAL PROPERTY INFRINGEMENT RELATED IN ANY MANNER TO USE OF INFORMATION, DEVICES, OR TECHNOLOGY DESCRIBED HEREIN OR OTHERWISE. Devices sold by ZiLOG, Inc. are covered by warranty and limitation of liability provisions appearing in the ZiLOG, Inc. Terms and Conditions of Sale. ZiLOG, Inc. makes no warranty of merchantability or fitness for any purpose Except with the express written approval of ZiLOG, use of information, devices, or technology as critical components of life support systems is not authorized. No licenses are conveyed, implicitly or otherwise, by this document under any intellectual property rights.



Z53C80

SMALL COMPUTER SYSTEM INTERFACE (SCSI)

FEATURES

- DMA or programmed I/O data transfers
- Arbitration support
- Supports normal or block mode DMA
- Memory or I/O mapped CPU interface
- Asynchronous interface, supports 3 Mbytes/sec
- Direct SCSI bus interface with on-board 48mA drivers
- Supports target and initiator roles
- Meets SCSI protocol as defined in ANSI X3.131-1986 standard
- Added "Glitch Eater" enhancement to minimize bus reflection

GENERAL DESCRIPTION

The Z53C80 SCSI (Small Computer System Interface) controller is a 44-pin PLCC, or 48-pin DIP CMOS device. It is designed to implement the SCSI protocol as defined by the ANSI X3.131-1986 standard, and is fully compatible with the industry standard 5380. It is capable of operating both as a target and as an initiator. Special high-current open-drain outputs enable it to directly interface to the SCSI bus. The Z53C80 has the necessary interface hook-ups so the system CPU can communicate with it as with any other peripheral device. The CPU can read from, or write to, the SCSI registers which are addressed as standard or memory-mapped I/Os.

The Z53C80 increases the system performance by minimizing the CPU intervention in DMA operations which the SCSI controls. The CPU is interrupted by the SCSI when it detects a bus condition that requires attention. It also supports arbitration and reselection. The Z53C80 has the proper handshake signals to support normal and block mode DMA operations with most DMA controllers available.

The added enhancement known as the "Glitch Eater" is used to minimize effects of bus reflection on improperly terminated SCSI bus applications. The high frequency

reflections that can occur on the SCSI bus are filtered out, reducing the sensitivity of the inputs, specifically /REQ and /ACK to bus signal reflections. Figure 1 shows a worst case input waveform (labeled A), along with the filtered input (labeled B) and the output of a Schmitt trigger used to provide the hysteresis required on SCSI inputs (labeled C). This enhancement is a requirement for the device to function properly in a Apple Macintosh® environment.

Notes:

All Signals with a preceding front slash, "/", are active Low, e.g.: B/W (WORD is active Low); /B/W (BYTE is active Low, only).

Power connections follow conventional descriptions below:

Connection	Circuit	Device
Power	V_{cc}	V_{DD}
Ground	GND	V_{SS}

* Apple Macintosh is a registered trademark of Apple Computer, Inc.

GENERAL DESCRIPTION (Continued)

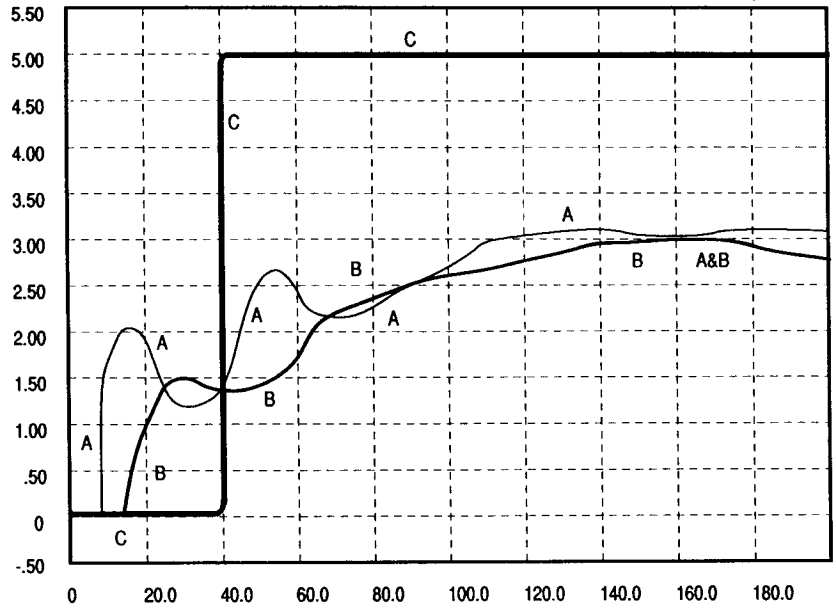

Figure 1. Worst Case Unfiltered Input (A), Filtered Input (B), Output of Schmitt Trigger Used to Provide Hysteresis (C).

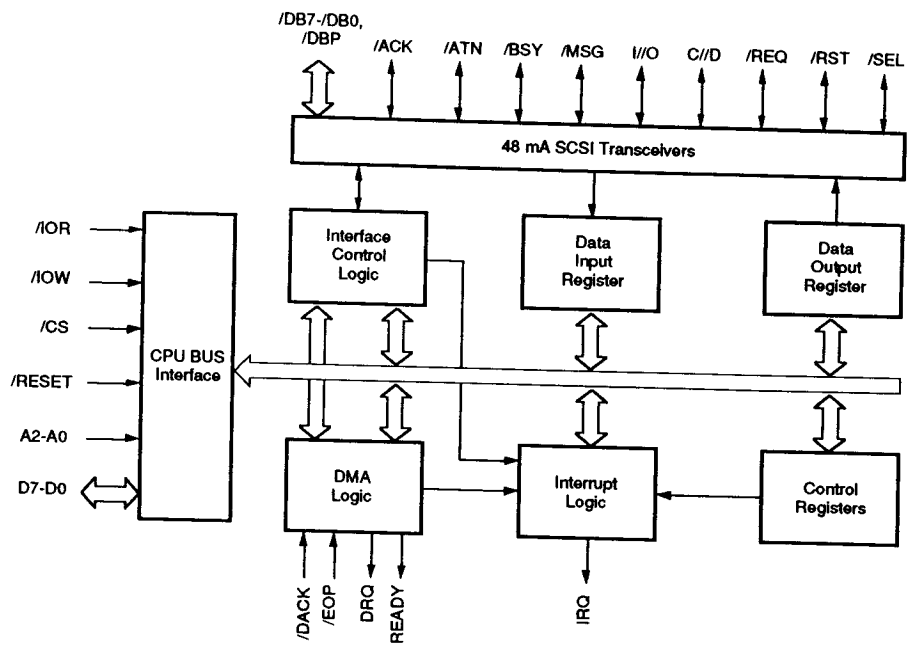

Figure 2a. SCSI Block Diagram

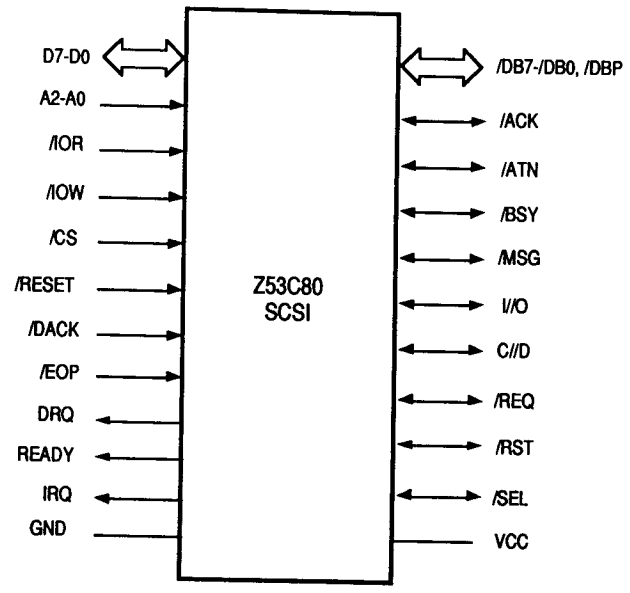

Figure 2b. SCSI Pin Functions

GENERAL DESCRIPTION (Continued)

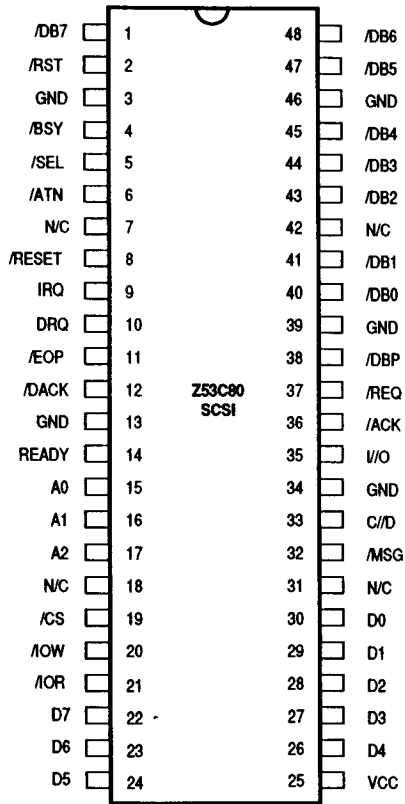

Figure 3. 48-Pin DIP Pin Assignments

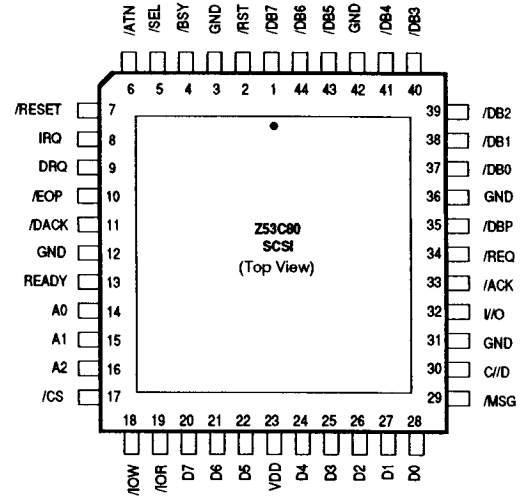

Figure 4. 44-Pin PLCC Pin Assignments

PIN DESCRIPTION

Microprocessor Bus

A2-A0. Address Lines (Input). Address lines are used to access all internal registers with */CS*, */IOR*, and */IOW*.

/CS. /Chip Select (Input, active Low). */CS*, in conjunction with */RD* or */WR*, enables the internal register selected by A2-A0, to be read from or write to. */CS* and */DACK* must never be active simultaneously.

/DACK. /DMA Acknowledge (Input, active Low). */DACK*, in conjunction with */IOR* and */IOW*, is used to enable reading or writing the SCSI I/O Data Registers when in the DMA Mode. When the DRQ has acknowledged that the byte has been successfully transferred to or from the DMA controller, this signal is asserted. */DACK* and */CS* must never be active simultaneously.

DRQ. DMA Request (Output, active High). This signal is asserted when the chip is ready to transfer a data byte to and from the DMA controller. The DMA Request will be asserted only if the DMA Mode bit (Register 2, Bit 1) is set. The transfer is complete upon reception of */DACK*.

D7-D0. Data Lines (Bidirectional; Tri-State, active High): The Data Bus lines carry data and commands to and from SCSI. D7 is the most significant bit of this bus.

/EOP. /End of Process (Input, active Low). To terminate a DMA transfer, this signal is asserted. The current byte will be transferred but no additional bytes will be requested if asserted during a DMA cycle. */EOP* can be used to generate an interrupt when it is received from a DMA Controller.

/IOR. /I/O Read (Input, active Low). This signal is used to read an internal register selected by */CS* and A2-A0. The Input Data Register can also be selected by this signal when */DACK* is active during DMA transfers.

/IOW. /I/O Write (Input, active Low). This signal is used to write to an internal register selected by */CS* and A2-A0. The Output Data Register can also be selected by this signal when used with */DACK* during DMA transfers.

IRQ. Interrupt Request (Output, active High). IRQ alerts the microprocessor of an error condition or an event completion. Most of the interrupts are individually maskable.

READY. Ready (Output, active High). This signal can be used to control the data transfer handshaking of block mode DMA transfers. READY is asserted to indicate that the chip is ready to transfer data and remains false after a transfer until the chip is ready for another DMA transfer. READY is always asserted when the DMA Mode Bit is a zero.

/RESET. /Reset (Input, active Low). */RESET* clears all registers and has no effect upon the SCSI */RST* signal. Therefore it does not reset the SCSI bus.

Power Signals

V _{cc}	+5 Volt Power Supply
GND	Ground
N/C	No Connect

SCSI BUS

The following signals are all bidirectional, active Low, open-drain, with 48 mA sink capacity. All pins interface directly with the SCSI Bus.

/ACK. /Acknowledge (Bidirectional, Open Drain, Active Low). /ACK is driven by the Initiator and indicates an acknowledgement for a SCSI data transfer. /ACK is received as a response to the /REQ Signal in the Target role.

/ATN. /Attention (Bidirectional, Open Drain, Active Low). /ATN is driven by the Initiator and indicates an attention condition. /ATN is received and is responded to by entering the Message Out Phase in the Target role.

/BSY. /Busy (Bidirectional, Open Drain, Active Low). /BSY indicates that the SCSI Bus is being occupied. /BSY can be driven by both the Target and the Initiator device.

/C//D. /Control//Data (Bidirectional, Open Drain, Active Low). /C//D indicates Control or Data information is on the SCSI Bus. This signal is driven by a Target and is received by the Initiator.

/I/O. /Input//Output (Bidirectional, Open Drain, Active Low). /I/O is driven by a Target and controls the direction of data transfer on the SCSI Bus. When asserted, this signal indicates input to the Initiator. When not asserted, this signal indicates output from the Initiator. This signal is also used to recognize the difference between the Selection and Reselection Phases.

/MSG. /Message (Bidirectional, Open Drain, Active Low). The Target drives /MSG active during the Message Phase and is received by the Initiator.

/REQ. /Request (Bidirectional, Open Drain, Active Low). Received by the Initiator and driven by a Target, /REQ indicates a request for an SCSI data-transfer handshake.

/RST. SCSI Bus RESET (Bidirectional, Open Drain, Active Low). The /RST signal shows a SCSI Bus RESET condition has occurred.

/DB7-/DB0,/DBP. /Data Bits, /Parity Bits (Bidirectional, Open Drain, Active Low). These eight data bits (/DB7-/DB0), plus a parity bit (/DBP) form the SCSI Data Bus. /DB7 has the highest priority during the Arbitration phase and is the most significant bit (MSB). Data parity is odd and is always generated and optionally checked, which is not valid during Arbitration.

/SEL. /Select (Bidirectional, Open Drain, Active Low). /SEL is used by a Target to select an Initiator, or by an Initiator to reselect a Target.

FUNCTIONAL DESCRIPTION

General. The Small Computer System interface (SCSI) device has a set of eight registers that are controlled by the CPU. By reading and writing the appropriate registers, the CPU may initiate any SCSI Bus activity or may sample and assert any signal on the SCSI Bus. This allows the user to implement all or any of the SCSI protocol in software. These registers are read (written) by activating /CS with an address on A2-A0 and then issuing a /RD (/WR) pulse. This section describes the operation of the internal registers (Table 1).

Table 1. Register Summary

Address			R/W	Register Name
A2	A1	A0		
0	0	0	R	Current SCSI Data
0	0	0	W	Output Data
0	0	1	R/W	Initiator Command
0	1	0	R/W	Mode
0	1	1	R/W	Target Command
1	0	0	R	Current SCSI Bus Status
1	0	0	W	Select Enable
1	0	1	R	Bus and Status
1	0	1	W	Start DMA Send
1	1	0	R	Input Data
1	1	0	W	Start DMA Target Receive
1	1	1	R	Reset Parity/Interrupt
1	1	1	W	Start DMA Initiator Receive

Data Registers. The data registers are used to transfer SCSI commands, data, status, and message bytes between the microprocessor Data Bus and the SCSI Bus. The SCSI does not interpret any information that passes through the data registers. The data registers consist of the transparent Current SCSI Data Register, the Output Data Register, and the Input Data Register.

Current SCSI Data Register. Address 0 (Read Only). The Current SCSI Data Register (Figure 5) is a read-only register which allows the microprocessor to read the active SCSI Data Bus. This is accomplished by activating /CS with an address on A2-A0 and issuing a /RD pulse. If parity checking is enabled, the SCSI Bus parity is checked at the beginning of the read cycle. This register is used during a programmed I/O data read or during Arbitration to check for higher priority arbitrating devices. Parity is not guaranteed valid during Arbitration.

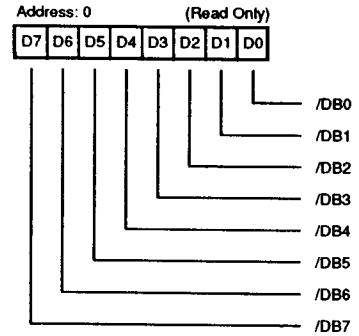

Figure 5. Current SCSI Data Register

Output Data Register. Address 0 (Write Only). The Output Data Register (Figure 6) is a write-only register that is used to send data to the SCSI Bus. This is accomplished by either using a normal CPU write, or under DMA control, by using /WR and /DACK. This register also asserts the proper ID bits on the SCSI Bus during the Arbitration and Selection phases.

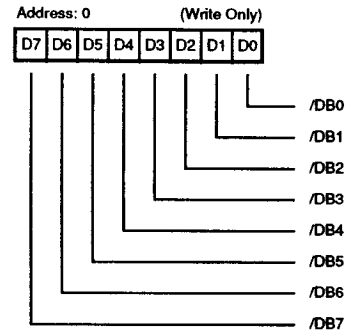

Figure 6. Output Data Register

FUNCTIONAL DESCRIPTION (Continued)

Input Data Register. Address 6 (Read Only). The input Data Register (Figure 7) is a read-only register that is used to read latched data from the SCSI Bus. Data is latched either during a DMA Target receive operation when /ACK goes active or during a DMA Initiator receive when /REQ goes active. The DMA Mode bit (Mode Register bit 1) must be set before data can be latched in the Input Data Register. This register is read under DMA control using /RD and /DACK. Parity is optionally checked when the Input Data Register is loaded.

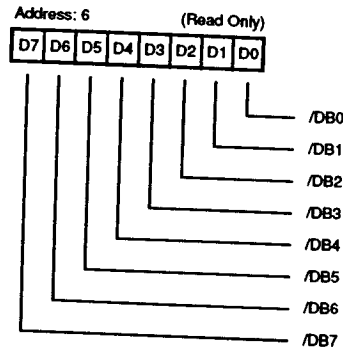

Figure 7. Input Data Register

Initiator Command Register. Address 1 (Read/Write). The Initiator Command Register (Figures 8 and 9) are read and write registers which assert certain SCSI Bus signals, monitors those signals, and monitors the progress of bus arbitration. Many of these bits are significant only when being used as an Initiator; however, most can be used during Target role operation.

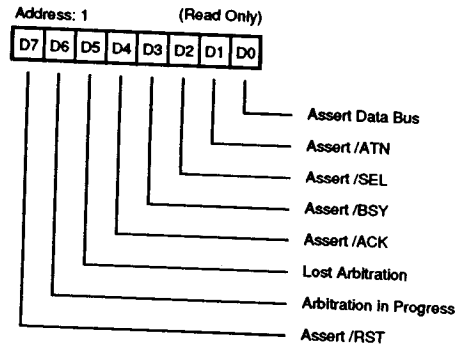

Figure 8. Initiator Command Register (Register Read)

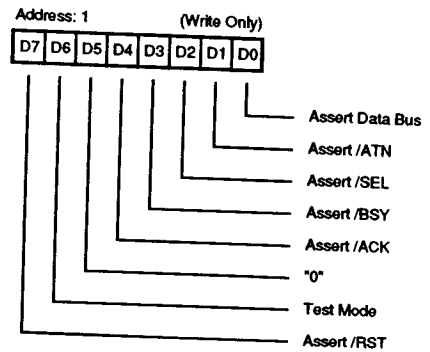

Figure 9. Initiator Command Register (Register Write)

The following describes the operation of all bits in the Initiator Command Register.

Bit 0. Assert Data Bus. The Assert Data Bus bit, when set, allows the contents of the Output Data Register to be enabled as chip outputs on the signals /DB7-/DB0. Parity is also generated and asserted on /DBP.

When connected as an Initiator, the outputs are only enabled if the Target Mode bit (Mode Register, bit 6) is False, the received signal /I/O is False, and the phase signals C//D, /I/O, and /MSG match the contents of the Assert C//O, Assert /I/O and Assert /MSG in the Target Command Register.

This bit should also be set during DMA send operations.

Bit 1. Assert/ATN/. Bit 1 may be asserted on the SCSI Bus by setting this bit to a 1 if the Target Mode bit (Mode Register, bit 6) is False. /ATN is normally asserted by the initiator to request a Message Out bus phase. Note that since Assert/SEL and Assert/ATN are in the same register, a select with /ATN may be implemented with one CPU write /ATN may be deasserted by resetting this bit to zero. A read on this register simply reflects the status of this bit.

Bit 2. Assert/SEL. Writing a 1 into this bit position asserts /SEL onto the SCSI Bus. /SEL is normally asserted after Arbitration has been successfully completed /SEL may be disabled by resetting bit 2 to a 0. A read of this register reflects the status of this bit.

Bit 3. Assert/BSY. Writing a 1 into this bit position asserts /BSY onto the SCSI Bus. Conversely, a 0 resets the /BSY signal. Asserting /BSY indicates a successful selection or reselection. Resetting this bit creates a Bus-Disconnect condition. Reading this register reflects bit status.

Bit 4. Assert/ACK. Bit 4 is used by the bus initiator to assert /ACK on the SCSI Bus. In order to assert /ACK, the Target Mode bit (Mode Register, bit 6) must be False. Writing a zero to this bit deasserts /ACK. Reading this register reflects bit status.

Bit 5. "0" (Write Bit). Bit 5 should be written with a 0 for proper operation.

Bit 5. LA (Lost Arbitration - Read Bit). Bit 5, when active, indicates that the SCSI detected a Bus-Free condition, arbitrated for use of the bus by asserting /BSY and its ID on the Data Bus, and lost Arbitration due to /SEL being asserted by another bus device. This bit is active only when the Arbitrate bit (Mode Register, bit 0) is active.

Bit 6. Test Mode (Write Bit). Bit 6 is written during a test environment to place all output drivers, in the high impedance state.

Bit 6. AIP (Arbitration in Process - Read Bit). Bit 6 is used to determine if Arbitration is in progress. For this bit to be active, the Arbitrate bit (Mode Register, bit 0) must have been set previously. It indicates that a Bus-Free condition has been detected and that the chip has asserted /BSY and put the contents of the Output Data Register onto the SCSI Bus. AIP will remain active until the Arbitrate bit is reset.

Bit 7. Assert/RST. Whenever a one is written to bit 7 of the Initiator Command Register, the /RST signal is asserted on the SCSI Bus. The /RST signal will remain asserted until this bit is reset or until an external /RESET occurs. After this bit is set (1), IRQ goes active and all internal logic and control registers are reset (except for the interrupt latch and the Assert/RST bit). Writing a zero to bit 7 of the Initiator Command Register deasserts the /RST signal. The status of this bit is monitored by reading the Initiator Command Register.

Mode Register. Address 2 (Read/Write). The Mode Register controls the operation of the chip. This register determines whether the SCSI operates as an Initiator or a Target, whether DMA transfers are being used, whether parity is checked, and whether interrupts are generated on various external conditions. This register is read to check the value of these internal control bits (Figure 10).

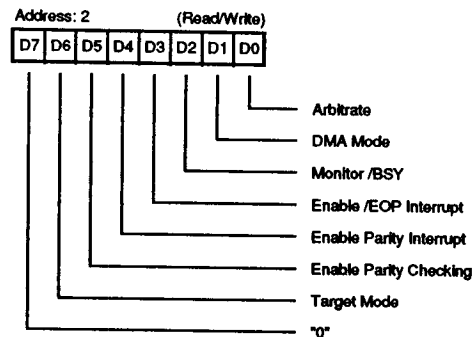

Figure 10. Mode Register

FUNCTIONAL DESCRIPTION (Continued)

Bit 0. Arbitrate. The Arbitrate bit is set (1) to start the Arbitration process. Prior to setting this bit, the Output Data Register should contain the proper SCSI device ID value. Only one data bit should be active for SCSI Bus Arbitration. The SCSI waits for a Bus-Free condition before entering the Arbitration phase. The results of the Arbitration phase is determined by reading the status bits LA and AIP (Initiator Command Register, bits 5 and 6, respectively).

Bit 1. DMA Mode. The DMA Mode bit is normally used to enable a DMA transfer and must be set (1) prior to writing Start DMA Send Register, Start DMA Target Receive Register, and Start DMA Initiator Receive Register. These three registers are used to start DMA transfers. The Target Mode bit (Mode Register, bit 6) must be consistent with writes to Start DMA Target Receive and Start DMA Initiator Receive Registers [i.e., set (1) for a write to start DMA Target Receive Register and set (0) for a write to Start DMA Initiator Receive Register]. The control bit Assert Data Bus (Initiator Command Register, bit 0) must be True (1) for all DMA send operations. In the DMA mode, /REQ and /ACK are automatically controlled.

The DMA Mode bit is not reset upon the receipt of an /EOP signal. Any DMA transfer is stopped by writing a zero into this bit location; however, care must be taken not to cause /CS and /DACK to be active simultaneously.

Bit 2. Monitor Busy. The Monitor Busy bit, when True (1), causes an interrupt to be generated for an unexpected loss of /BSY. When the interrupt is generated due to loss of /BSY, the lower six bits of the Initiator Command Register are reset (0) and all signals are removed from the SCSI Bus.

Bit 3. Enable/EOP interrupt. The enable /EOP interrupt, when set (1), causes an interrupt to occur when the /EOP (End of Process) signal is received from the DMA controller logic.

Bit 4. Enable Parity Interrupt. The Enable Parity Interrupt bit, when set (1), will cause an interrupt (IRQ) to occur if a parity error is detected. A parity interrupt will only be generated if the Enable Parity Checking bit (bit 5) is also enabled (1).

Bit 5. Enable Parity Checking. The Enable Parity Checking bit determines whether parity errors are ignored or saved in the parity error latch. If this bit is reset (0), parity is ignored. Conversely, if this bit is set (1), parity errors are saved.

Bit 6. Targetmode. The Targetmode bit allows the SCSI to operate as either a SCSI Bus Initiator, bit reset (0), or as a SCSI Bus Target device, bit set (1). If the signals /ATN and /ACK are to be asserted on the SCSI Bus, the Targetmode bit must be reset (0). If the signals C//D, I//O, /MSG, and /REQ are to be asserted on the SCSI Bus, the Targetmode bit must be set (1).

Bit 7. 0. Bit 7 should be written with a zero for proper operation.

Target Command Register. Address 3(Read/Write). When connected as a target device, the Target Command Register (Figure 11) allows the CPU to control the SCSI Bus Information Transfer phase and/or to assert /REQ by writing this register. The Targetmode bit (Mode Register, bit 6) must be True (1) for bus assertion to occur. The SCSI Bus phases are described in Table 2.

Table 2. SCSI Information Transfer Phase

Bus Phase	ASSERT I//O	ASSERT C//D	ASSERT /MS
Data Out	0	0	0
Unspecified	0	0	1
Command	0	1	0
Message Out	0	1	1
Data In	1	0	0
Unspecified	1	0	1
Status	1	1	0
Message In	1	1	1

When connected as an Initiator with DMA Mode True, if the phase lines I//O, C//D, and /MSG do not match the phase bits in the Target Command Register, a phase mismatch interrupt is generated when /REQ goes active. To send data as an Initiator, the Assert I//O, Assert C//D, and Assert /MSG bits must match the corresponding bits in the Current SCSI Bus Status Register. The Assert /REQ bit (bit 3) has no meaning when operating as an Initiator.

Bits 4, 5, and 6 are not used.

Bit 7. *Last Byte Sent* (Read Only). The End Of DMA Transfer bit (Bus and Status Register, bit 7) only indicates when the last byte was received from the DMA controller. The Last Byte Sent bit can be used to flag that the last byte of the DMA send operation has been transferred on the SCSI Data Bus.

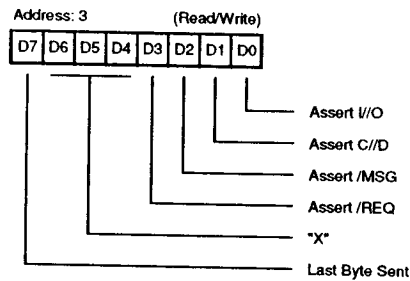

Figure 11. Target Command Register

Current SCSI Bus Status Register. Address 4 (Read Only). The Current SCSI Bus Register is a read-only register which is used to monitor seven SCSI Bus control signals, plus the Data Bus parity bit. For example, an Initiator device can use this register to determine the current bus phase and to poll /REQ for pending data transfers. This register may also be used to determine why a particular interrupt occurred. Figure 12 describes the Current SCSI Bus Status Register.

Select Enable Register. Address 4 (Write Only). The Select Enable Register (Figure 13) is a write-only register which is used as a mask to monitor a signal ID during a selection attempt. The simultaneous occurrence of the correct ID bit, /BSY FALSE, and /SEL TRUE will cause an interrupt. This interrupt can be disabled by resetting all bits in this register. If the Enable Parity Checking bit (Mode Register, bit 5) is active (1), parity is checked during selection.

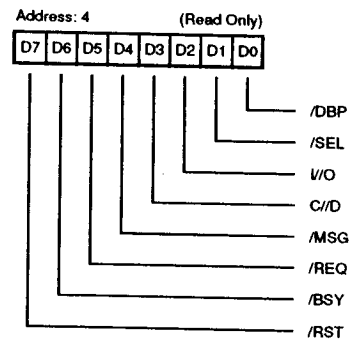

Figure 12. Current SCSI Bus Status Register

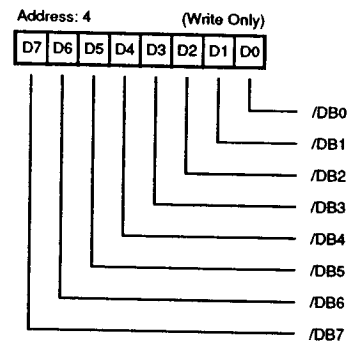

Figure 13. Select Enable Register

FUNCTIONAL DESCRIPTION (Continued)

Bus and Status Register. Address 5 (Read Only). The Bus and Status Register (Figure 14) is a read-only register which can be used to monitor the remaining SCSI control signals not found in the Current SCSI Bus Status Registers (/ATN and /ACK), as well as six other status bits. The following describes each bit of the Bus Status Register individually.

Bit 0. /ACK. Bit 0 reflects the condition of the SCSI Bus control signal /ACK. This signal is normally monitored by the Target device.

Bit 1. /ATN. Bit 1 reflects the condition of the SCSI Bus control signal /ATN. This signal is normally monitored by the Target device.

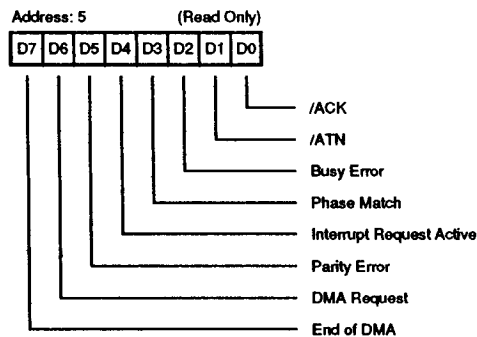

Figure 14. Bus and Status Register

Bit 2. Busy Error. The Busy Error bit is active if an unexpected loss of the /BSY signal has occurred. This latch is set whenever the Monitor Busy bit (Mode Register, bit 2) is True and /BSY is False. An unexpected loss of /BSY disables any SCSI outputs and resets the DMA Mode bit (Mode Register, bit 1).

Bit 3. Phase Match. The SCSI signals /MSG, C//D, and I//O, represent the current information transfer phase. The Phase Match bit indicates whether the current SCSI Bus phase matches the lower three bits of the Target Command Register. Phase Match is continuously updated and is only significant when operating as a Bus Initiator. A phase match is required for data transfers to occur on the SCSI Bus.

Bit 4. Interrupt Request Active. Bit 4 is set if an enabled interrupt condition occurs. It reflects the current state of the IRQ output and can be cleared by reading the Reset Parity/Interrupt Register.

Bit 5. Parity Error. Bit 5 is set if a parity error occurs during a data receive or a device selection. The Parity Error bit can only be set (1) if the Enable Parity Check bit (Mode Register, bit 5) is active (1). This bit may be cleared by reading the Reset Parity/Interrupt Register.

Bit 6. DMA Request. The DMA Request bit allows the CPU to sample the output pin DRQ. DRQ can be cleared by asserting /DACK or by resetting the DMA MODE bit (bit 1) in the Mode Register. The DRQ signal does not reset when a phase-mismatch interrupt occurs.

Bit 7. End Of DMA Transfer. The End Of DMA Transfer bit is set if /EOP, /DACK, and either /RD or /WR are simultaneously active for at least 100 ns. Since the /EOP signal can occur during the last byte sent to the Output Data Register, the /REQ and /ACK signals should be monitored to ensure that the last byte has been transferred. This bit is reset when the DMA MODE bit is reset (0) in the Mode Register.

DMA Registers. Three write-only registers are used to initiate all DMA activity. They are: Start DMA Send, Start DMA Target Receive, and Start DMA Initiator Receive. Performing a write operation into one of these registers starts the desired type of DM transfer. Data presented to the SCSI on signals D7-D0 during the register write is meaningless and has no effect on the operation. Prior to writing these registers, the DMA Mode bit (bit 1), and the Target mode bit (bit 6) in the Mode Register must be appropriately set. The individual registers are briefly described as follows:

Start DMA Send. Address 5 (Write Only). This register is written to initiate a DMA send, from the DMA to the SCSI Bus, for either Initiator or Target role operations. The DMA Mode bit (Mode Register, bit 1) is set prior to writing this register.

Start DMA Target Receive. Address 6 (Write Only). This register is written to initiate a DMA receive - from the SCSI Bus to the DMA, for Target operation only. The DMA Mode bit (bit 1) and the Targetmode bit (bit 6) in the Mode Register must both be set (1) prior to writing this register.

Start DMA Initiator Receive. Address 7 (Write Only). This register is written to initiate a DMA receive from the SCSI Bus to the DMA, for Initiator operation only. The DMA Mode bit (bit 6) must be False (0) in the Mode Register prior to writing this register.

Reset Parity/Interrupt. Address 7 (Read Only). Reading this register resets the Parity Error bit (bit 5), the Interrupt Request bit (bit 4), and the Busy Error bit (bit 2) in the Bus and Status Register.

On-Chip SCSI Hardware Support. The SCSI is easy to use because of its simple architecture. The chip allows direct control and monitoring of the SCSI Bus by providing a latch for each signal. However, portions of the protocol define timings which are much too quick for traditional microprocessors to control. Therefore, hardware support has been provided for DMA transfers, bus arbitration, phase change monitoring, bus disconnection, bus reset, parity generation, parity checking, and device selection/reselection.

Arbitration is accomplished using a Bus-Free filter to continuously monitor /BSY. If /BSY remains inactive for at least 400 ns, the SCSI is considered free and Arbitration may begin. Arbitration will begin if the bus is free, /SEL is inactive, and the Arbitrate bit (Mode Register, bit 0) is active. Once arbitration has begun (/BSY asserted), an arbitration delay of 2.2 μ s must elapse before the Data Bus can be examined to determine if Arbitration is enabled. This delay is implemented in the controlling software driver.

The Z53C80 is a clockwise device. Delays such as bus-free delay, bus-set delay, and bus-settle delay are implemented using gate delays. These delays may differ between devices because of inherent process variations, but are well within the proposed ANSI X3.131 - 1986 specification.

Interrupts. The Z53C80 provides an interrupt output (IRQ) to indicate a task completion or an abnormal bus occurrence. The use of interrupts is optional and may be disabled by resetting the appropriate bits in the Mode Register or the Select Enable Register.

When an interrupt occurs, the Bus and Status Register and the Current SCSI Bus Status Register (Figures 12 and 14) must be read to determine which condition created the interrupt. IRQ can be reset simply by reading the Reset Parity/Interrupt Register or by an external chip reset /RESET active for 100 ns.

Assuming the Z53C80 has been properly initialized, an interrupt will be generated if the chip is selected or reselected, if an /EOP signal occurs, if a parity error occurs during a data transfer, if a bus phase mismatch occurs, or if a SCSI Bus disconnection occurs.

Selection Reselection. The Z53C80 generates a select interrupt if SEL is active (0), its device ID is True and /BSY is False for at least a bus-settle delay. If I/O is active, this is considered a reselect interrupt. The correct ID bit is determined by a match in the Select Enable Register. Only a single bit match is required to generate an interrupt. This interrupt may be disabled by writing zeros into all bits of the Select Enable Register.

If parity is supported, parity should be good during the selection phase. Therefore, if the Enable Parity bit (Mode Register, bit 5) is active, the Parity Error bit is checked to ensure that a proper selection has occurred. The Enable Parity Interrupt bit need not be set for this interrupt to be generated.

The proposed SCSI specification also requires that no more than two device IDs be active during the selection process. To ensure this, the Current SCSI Data Register is read.

The proper values for the Bus and Status Register and the Current SCSI Bus Status Register are displayed in Figures 15 and 16, respectively.

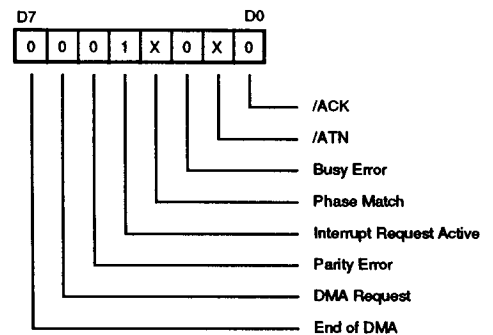

Figure 15. Bus and Status Register

FUNCTIONAL DESCRIPTION (Continued)

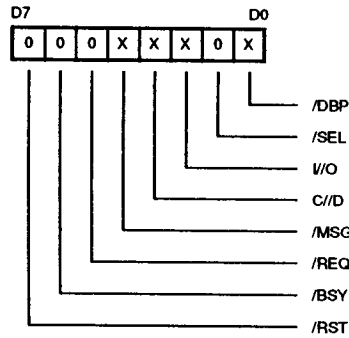

Figure 16. Current SCSI Bus Status Register

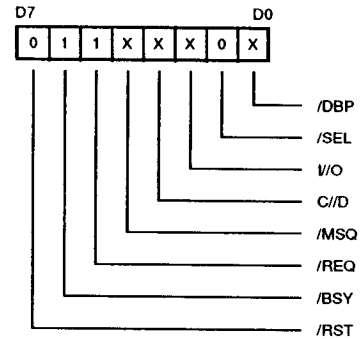

Figure 18. Current SCSI Bus Status Register

End of Process (EOP) Interrupt. An End Of Process signal (EOP) which occurs during a DMA transfer (DMA Mode True) will set the End of DMA Status bit (Bus and Status Register bit 7) and will optionally generate an interrupt if Enable EOP Interrupt bit (Mode Register, bit 3) is True. The /EOP pulse will not be recognized (End of DMA bit set) unless /EOP, /DACK, and either /RD or /WR are concurrently active for at least 50 ns. DMA transfers can still occur if /EOP was not asserted at the correct time. This interrupt is disabled by resetting the Enable EOP Interrupt bit.

The proper values for the Bus and Status Register and the Current SCSI Bus Status Register for this interrupt are shown in Figures 17 and 18.

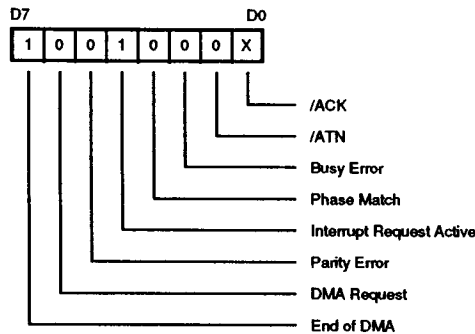

Figure 17. Bus and Status Register

The End of DMA bit is used to determine when a block transfer is complete. Receive operations are complete when there is no data left in the chip and no additional handshakes occurring. The only exception to this is receiving data as an Initiator and the Target opts to send additional data for the same phase. In this /REQ goes active and the new data is present in the Input Data Register. Since a phase-mismatch interrupt will not occur, /REQ and /ACK need to be sampled to determine that the Target is attempting to send more data.

For send operations, the End of DMA bit is set when the DMA finishes its transfers, but the SCSI transfer may still be in progress. If connected as a Target, /REQ and /ACK should be sampled until both are False. If connected as an Initiator, a phase change interrupt is used to signal the completion of the previous phase. It is possible for the Target to request additional data for the same phase. In this case, a phase change will not occur and both /REQ and /ACK are sampled to determine when the last byte was transferred.

SCSI Bus Reset. The SCSI generates an interrupt when the /RST signal transitions to True. The device releases all bus signals within a bus-clear delay of this transition. This interrupt also occurs after setting the Assert /RST bit (Initiator Command Register, bit 7). This interrupt cannot be disabled. (Note: /RST is not latched in bit 7 of the Current SCSI Bus Status Register and is not active when this port is read. For this case, the Bus Reset interrupt is determined by default.)

The proper values for the Bus and Status Register and the Current SCSI Bus Status Register are displayed in Figures 19 and 20, respectively.

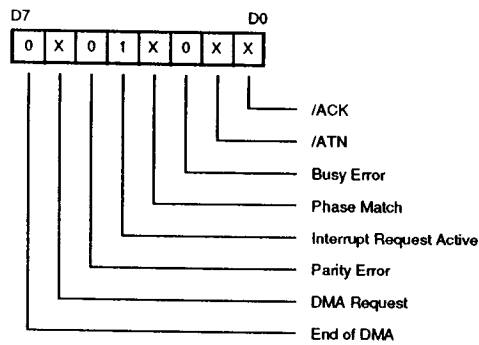

Figure 19. Bus and Status Register

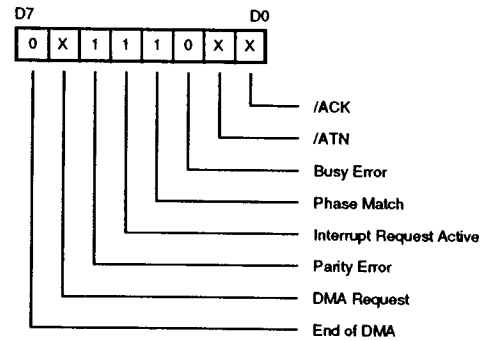

Figure 21. Bus and Status Register

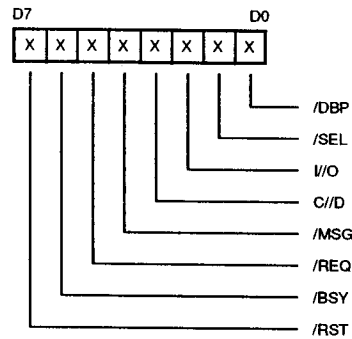

Figure 20. Current SCSI Bus Status Register

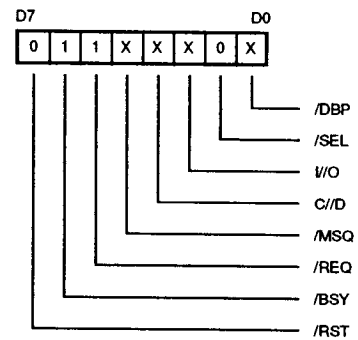

Figure 22. Current SCSI Bus Status Register

Parity Error. An interrupt is generated for a received parity error if the Enable Parity Check (bit 5) and the Enable Parity Interrupt (bit 4) bits are set (1) in the Mode Register. Parity is checked during a read of the Current SCSI Data Register and during a DMA receive operation. A parity error can be detected without generating an interrupt by disabling the Enable Parity Interrupt bit and checking the Parity Error flag (Bus and Status Register, bit 5).

The proper values for the Bus and Status Register and the Current SCSI Bus Status Register are displayed in Figures 21 and 22, respectively.

Bus Phase Mismatch. The SCSI phase lines have the signals I/O, C/D, and /MSG. These signals are compared with the corresponding bits in the Target Command Register: Assert I/O (bit 0), Assert C/D (bit 1), and Assert /MSG (bit 2). The comparison occurs continually and is reflected in the Phase Match bit (bit 3) of the Bus and Status Register. If the DMA Mode bit (Mode Register, bit 1) is active and a phase mismatch occurs when /REQ transitions from False to True, an interrupt (IRQ) is generated.

FUNCTIONAL DESCRIPTION (Continued)

A phase mismatch prevents the recognition of /REQ and removes the chip from the bus during an Initiator send operation (/DB7-/DB0 and /DBP will not be driven even through the Assert Data Bus bit (Initiator Command Register, bit 0). This may be disabled by resetting the DMA Mode bit (Note: It is possible for this interrupt to occur when connected as a Target if another device is driving the phase lines to a different state).

The proper values for the Bus and Status Register and the Current SCSI Bus Status Register are displayed in Figures 23 and 24, respectively.

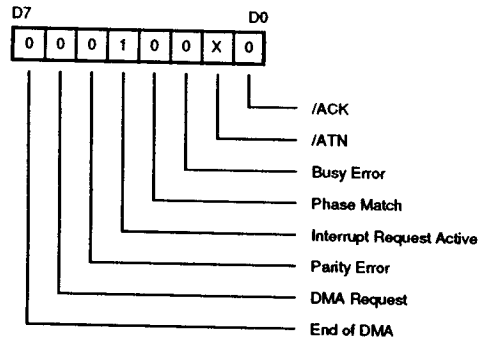

Figure 23. Bus and Status Register

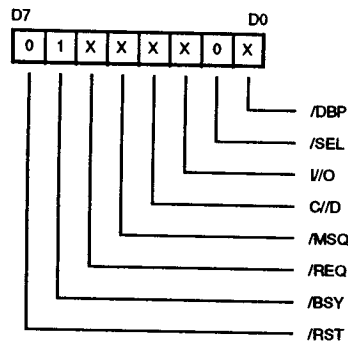

Figure 24. Current SCSI Bus Status Register

Loss of BSY. If the Monitor Busy bit (bit 2) in the Mode Register is active, an interrupt is generated if the BSY signal goes FALSE for at least a bus-settle delay. This interrupt is disabled by resetting the Monitor Busy bit. Register values are displayed in Figures 25 and 26.

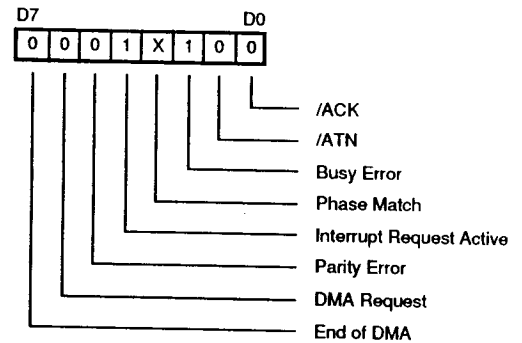

Figure 25. Bus and Status Register

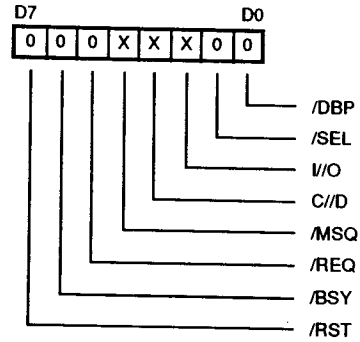

Figure 26. Current SCSI Bus Status Register

Reset Conditions. Three possible reset situations exist with the Z53C80, as follows:

Hardware Chip Reset. When the signal RST is active for at least 100 ns, the Z53C80 device is re-initialized and all internal logic and control registers are cleared. This is a chip reset only and does not create a SCSI Bus-Reset condition.

SCSI Bus Reset (/RST) Received. When a SCSI /RST signal is received, an IRQ interrupt is generated and a chip reset is performed. All internal logic and registers are cleared, except for the IRQ interrupt latch and the Assert /RST bit (bit 7) in the Initiator Command Register. (Note: The /RST signal may be sampled by reading the Current SCSI Bus Status Register, however, this signal is not latched and may not be present when this port is read.)

SCSI Bus Reset (/RST) Issued. If the CPU sets the Assert /RST bit (bit 7) in the Initiator Command Register, the /RST signal goes active on the SCSI Bus and an internal reset is performed. Again, all internal logic and registers are cleared except for the IRQ interrupt latch and the Assert /RST bit (bit 7) in the Initiator Command Register. The /RST signal will continue to be active until the Assert /RST bit is reset or until a hardware reset occurs.

Data Transfers. Data is transferred between SCSI Bus devices in one of four modes: 1) Programmed I/O, 2) Normal DMA, 3) Block Mode DMA, or 4) Pseudo DMA. The following sections describe these modes in detail (Note: for all data transfer operations /DACK and /CS should never be active simultaneously.)

Programmed I/O Transfers. Programmed I/O is the most primitive form of data transfer. The /REQ and /ACK handshake signals are individually monitored and asserted by reading and writing the appropriate register bits. This type of transfer is normally used when transferring small blocks of data such as command blocks or message and status bytes. An Initiator send operation would begin by setting the C//D, I//O, and /MSG bits in the Target Command Register to the correct state so that a phase match exists. In addition to the phase match condition, it is necessary for the Assert Data Bus bit (Initiator Command Register, bit 0) to be True and the received I/O signal to be False for the Z53C80 to send data. For each transfer, the data is loaded into the Output Data Register. The CPU then waits for the /REQ bit (Current SCSI Bus Status Register, bit 5) to become active. Once /REQ goes active, the Phase Match bit (Initiator Command Register, bit 4) is set. The /REQ bit is sampled until it becomes FALSE and the CPU resets the Assert /ACK bit to complete the transfer.

Normal DMA Mode. DMA transfers are normally used for large block transfers. The SCSI chip outputs a DMA

request (DRQ) whenever it is ready for a byte transfer. External DMA logic uses this DRQ signal to generate /DACK and a /RD or a /WR pulse to the Z53C80. DRQ goes inactive when /DACK is asserted and /DACK goes inactive some time after the minimum read or write pulse width. This process is repeated for every byte. For this mode, /DACK should not be allowed to cycle unless a transfer is taking place.

Block Mode Transfers. The Block Mode DMA transfers allow an external DMA controller, such as the Intel 8237, to perform successive DMA transfers without abandoning the data bus to the microprocessor. Keeping an active /DACK prevents the (Intel-type) CPUs from gaining control of the system bus. The Block Mode handshaking method does not increase the transfer rate. Preventing the CPU from multiplexing the system bus does not have any speed advantages. Therefore, this is not recommended for initiator use.

In the Block Mode, the SCSI chip asserts the DRQ signal to initiate the transfer. The DMA controller responds to the DRQ signal by asserting the /DACK and remains asserted throughout the transfer. The 53C80 asserts the READY signal after the /IOR or /IOW signals deassert, effectively replacing the DRQ signal. The READY signal for Intel-type DMA controllers extends the memory read and write signals. Therefore, D7-D0 is available to be read or written on the system bus until the SCSI chip is ready for the next transfer. This transfer method prevents the CPU from executing any action, such as a refresh cycle on the system bus. In the non-block DMA mode, the system bus is unoccupied until the 53C80 asserts DRQ. This indicates that the chip is ready for the next byte transfer. The advantage of this mode is that it allows the CPU to use the system bus while the 53C80 is transferring data across the SCSI bus.

Caution must be taken when executing this mode due to the operation of READY. For example, if a phase mismatch interrupt occurs, the READY signal will stay inactive and IRQ will be active. Then, the DMA controller cannot give the system bus back to the CPU for the 53C80 interrupt to be serviced since READY remains inactive. READY must be asserted to continue the bus cycle. Therefore, /EOP should be used in Block Mode so that the CPU can regain control of the bus after the last byte has been transferred. To make READY active again, reset the DMA Mode Bit.

Block Mode transfers are stopped in the same fashion as in the Block Mode. This is executed by resetting the DMA Mode Bit or using the /EOP signal. (See the previous section, Normal DMA Mode, for more information on stopping a DMA transfer.)

FUNCTIONAL DESCRIPTION (Continued)

Pseudo DMA Mode. To avoid monitoring and asserting the request/acknowledgment handshake signals for programmed I/O transfers, the system may be designed to implement a pseudo DMA mode. This mode is implemented by programming the Z53C80 to operate in the DMA mode, but using the CPU to emulate the DMA handshake. DRQ may be detected by polling the DMA Request bit (bit 6) in the Bus and Status Register, by sampling the signal through an external port, or by using it to generate a CPU interrupt. Once DRQ is detected, the CPU can perform a read or write data transfer. This CPU read/write is externally decoded to generate the appropriate /DACK and /RD or /WR signals.

Often, external decoding logic is necessary to generate the /CS signal. This same logic may be used to generate /DACK at no extra cost and provide an increased performance in programmed I/O transfers.

Halting a DMA Operation. The EOP signal is not the only way to halt a DMA transfer. A bus phase mismatch or a reset of the DMA MODE bit (Mode Register, bit 1) can also terminate a DMA cycle for the current bus phase.

Using the /EOP Signal. If /EOP is used, it should be asserted for at least 50 ns while /DACK and /RD or /WR are simultaneously active. Note, however, that if /RD or /WR is not active, an interrupt is generated, but the DMA activity continues. The /EOP signal does not reset the DMA MODE bit. Since the /EOP signal can occur during the last byte sent to the Output Data Register, the /REQ and /ACK signals are monitored to ensure that the last byte has transferred.

Bus Phase Mismatch Interrupt. A bus phase mismatch interrupt is used to halt the transfer if operating as an Initiator. Using this method frees the host from maintaining a data length counter and frees the DMA logic from providing the /EOP signal. If performing an Initiator send operation, the Z53C80 requires /DACK to cycle before /ACK goes inactive. Since phase changes cannot occur if /ACK is active, either /DACK must be cycled after the last byte is sent or the DMA Mode bit must be reset in order to receive the phase mismatch interrupt.

Resetting the DMA MODE Bit. A DMA operation may be halted at any time simply by resetting the DMA Mode bit. It is recommended that the DMA Mode bit be reset after receiving an /EOP or bus phase-mismatch interrupt. The DMA Mode bit must then be set before writing any of the start DMA registers for subsequent bus phases.

If resetting the DMA Mode bit is used instead of /EOP for Target role operation, then care must be taken to reset this bit at the proper time. If receiving data as a Target device, the DMA Mode bit must be reset once the last DRQ is received and before /DACK is asserted to prevent an additional /REQ from occurring. Resetting this bit causes DRQ to go inactive. However, the last byte received remains in the Input Data Register and may be obtained either by performing a normal CPU read or by cycling /DACK and /RD. In most cases, /EOP is easier to use when operating as a Target device.

READ REGISTERS

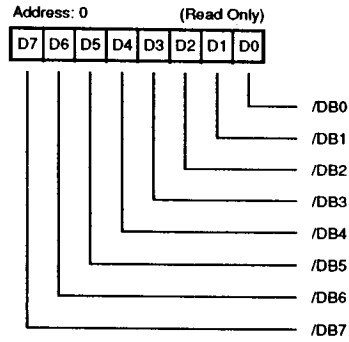

Figure 27. Current SCSI Data Register

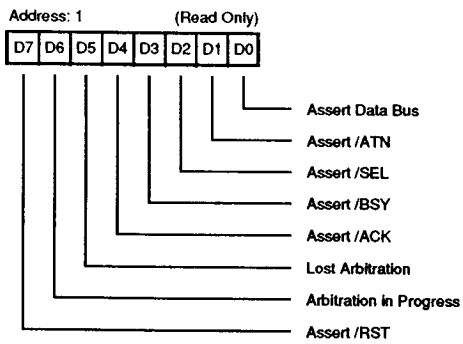

Figure 28. Initiator Command Register

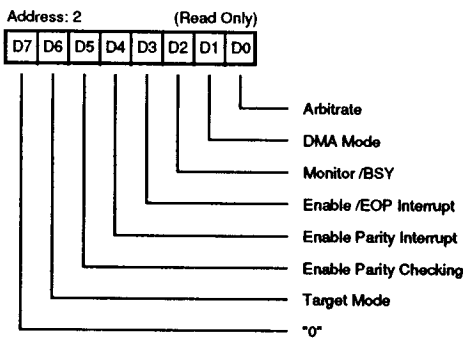

Figure 29. Mode Register

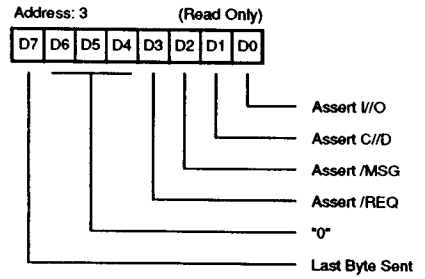

Figure 30. Target Command Register

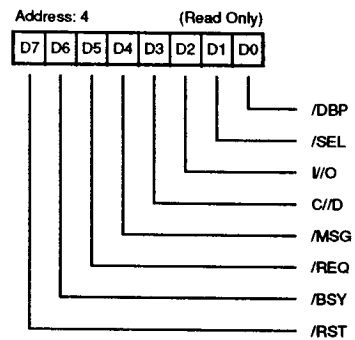

Figure 31. Current SCSI Bus Status Register

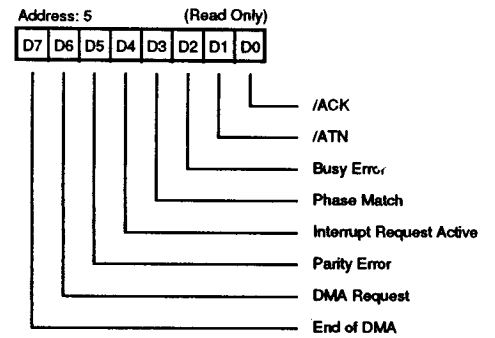

Figure 32. Bus and Status Register

READ REGISTERS (Continued)

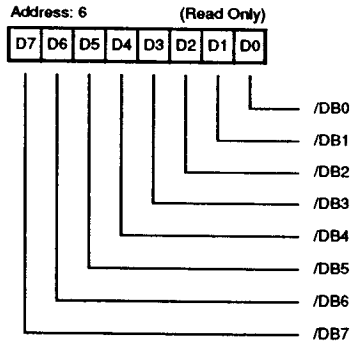

Figure 33. Input Data Register

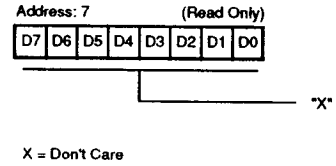

Figure 34. Reset Parity/Interrupt

WRITE REGISTERS

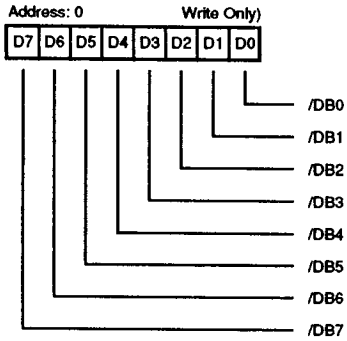

Figure 35. Output Data Register

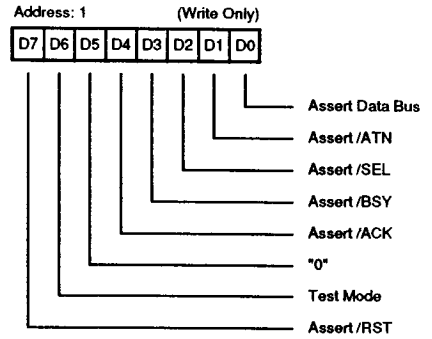

Figure 36. Initiator Command Register

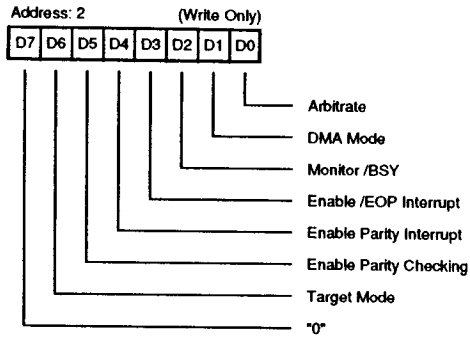

Figure 37. Mode Register

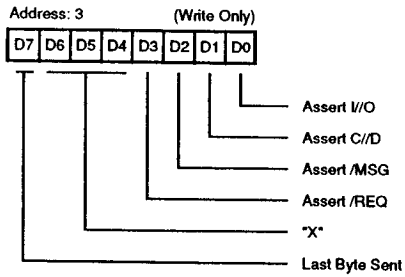

Figure 38. Target Command Register

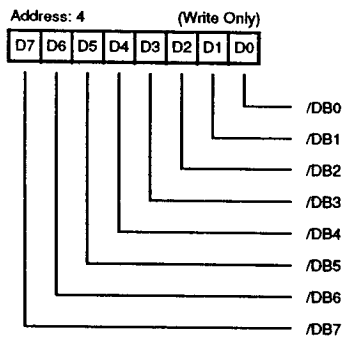

Figure 39. Select Enable Register

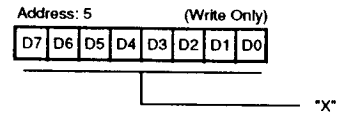

Figure 40. Start DMA Send

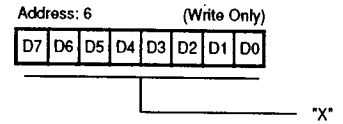

Figure 41. Start DMA Target Receive

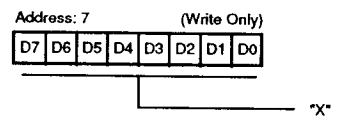

Figure 42. Start DMA Initiator Receive

ABSOLUTE MAXIMUM RATINGS

Voltages on all pins with respect to GND	-0.3V to +7.0V
Operating Ambient Temperature	See Ordering Information
Storage Temperature	-65°C to +150°C

Stresses greater than those listed under Absolute Maximum Ratings may cause permanent damage to this device. This is a stress rating only; operation of the device at any condition above those indicated in the operational sections of these specifications is not implied. Exposure to absolute maximum rating conditions for extended periods may affect device reliability.

STANDARD TEST CONDITIONS

The DC characteristics and capacitance section below apply for the following standard test conditions, unless otherwise noted. All voltages are referenced to GND. Positive current flows into the referenced pin. Standard conditions are as follows:

- $+4.75V \leq V_{cc} \leq +5.25V$
- GND = 0V
- T_A as specified in Ordering Information

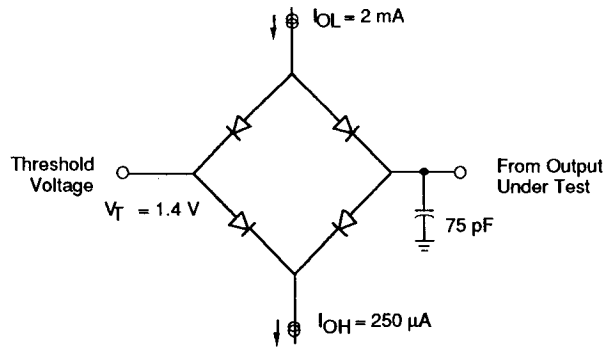

Figure 43. Standard Test Dynamic Load Circuit

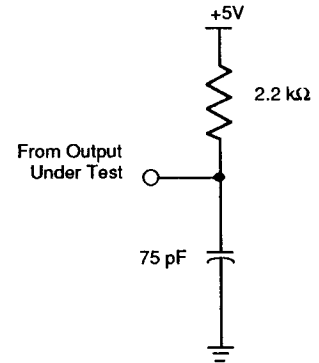

Figure 44. Open-Drain Test Load

DC CHARACTERISTICS

Symbol	Parameter	Condition	Min	Max	Units
V_{DD}	Supply Voltage		4.75	5.25	V
V_{IH}	High-Level Input Voltage		2.0	$V_{DD} + 0.5$	V
V_{IL}	Low-Level Input Voltage		$V_{SS} - 0.5$	0.8	V
I_{IH1}	High-Level Input Current SCSI Bus Pins	$V_{IH} = 5.25V$ $V_{IL} = 0V$		50	μA
I_{IH2}	High-Level Input Current All Other Pins	$V_{IH} = 5.25V$		10	μA
I_{IL1}	Low-Level Input Current SCSI Bus Pins (Except /RST)	$V_{IL} = V_{SS}$		-50	μA
I_{IL2}	Low-Level Input Current All Other Pins	$V_{IL} = V_{SS}$		-10	μA
V_{OH1}	High-Level Output Voltage	$I_{OH} = -4mA$	2.4	V_{DD}	V
V_{OL1}	Low-Level Output Voltage SCSI Bus Pins	$I_{OL} = 48 mA$	V_{SS}	0.5	V
V_{OL2}	Low-Level Output Voltage All Other Pins	$I_{OL} = 8 mA$	V_{SS}	0.4	V
I_{DD}	Supply Current			15	mA
T_A	Operating Free-Air Temperature		0	70	$^{\circ}C$

AC CHARACTERISTICS
CPU Write Cycle Timing Diagram

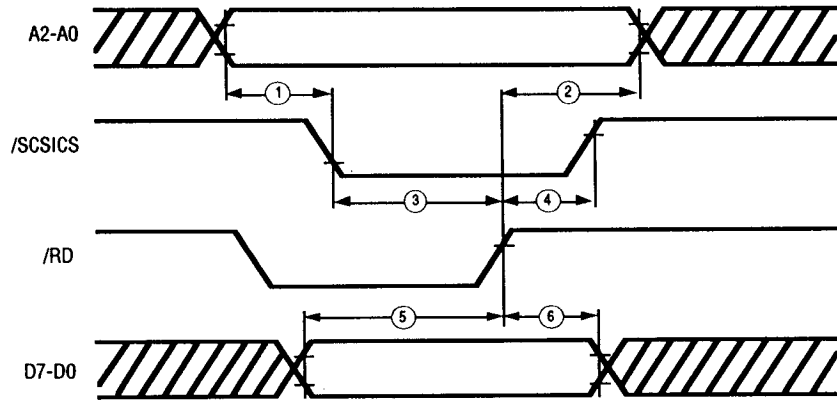

Figure 45. CPU Write Cycle

AC CHARACTERISTICS
CPU Write Cycle Table

No	Description	Min	Max	Units
1	Address Setup to Write Enable*	10		ns
2	Address Hold from End Write Enable*	10		ns
3	Write Enable Width*	40		ns
4	Chip Select Hold from End of /IOW	0		ns
5	Data Setup to end of Write Enable*	20		ns
6	Data Hold Time form End of /IOW	20		ns

Note:
* Write Enable is the occurrence of /WR and /CS

AC CHARACTERISTICS

CPU Read Cycle Timing Diagram

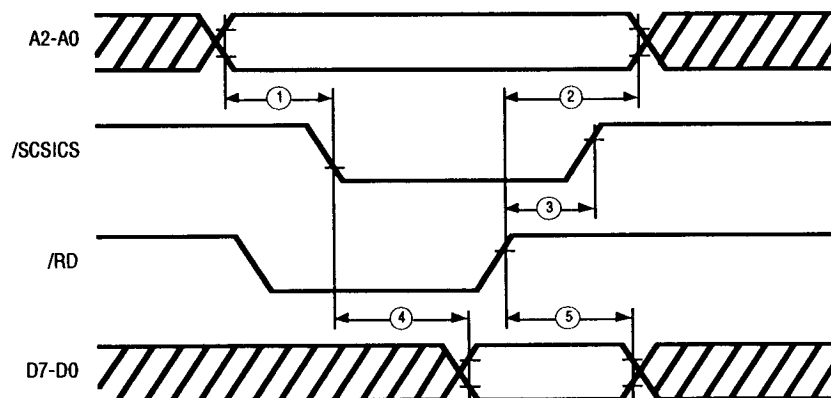

Figure 46. CPU Read Cycle

AC CHARACTERISTICS

CPU Read Cycle Table

No	Description	Min	Max	Units
1	Address Setup to Read Enable*	10		ns
2	Address Hold from End Read Enable*	10		ns
3	Chip Select Hold from End of /RD	0		ns
4	Data Access Time from Read Enable*		70	ns
5	Data Hold Time from End of Read Enable*	10		ns

Note:

* Read Enable is the occurrence of /RD and /CS

AC CHARACTERISTICS

DMA Write (Non-Block Mode) Initiator Send Cycle Timing Diagram

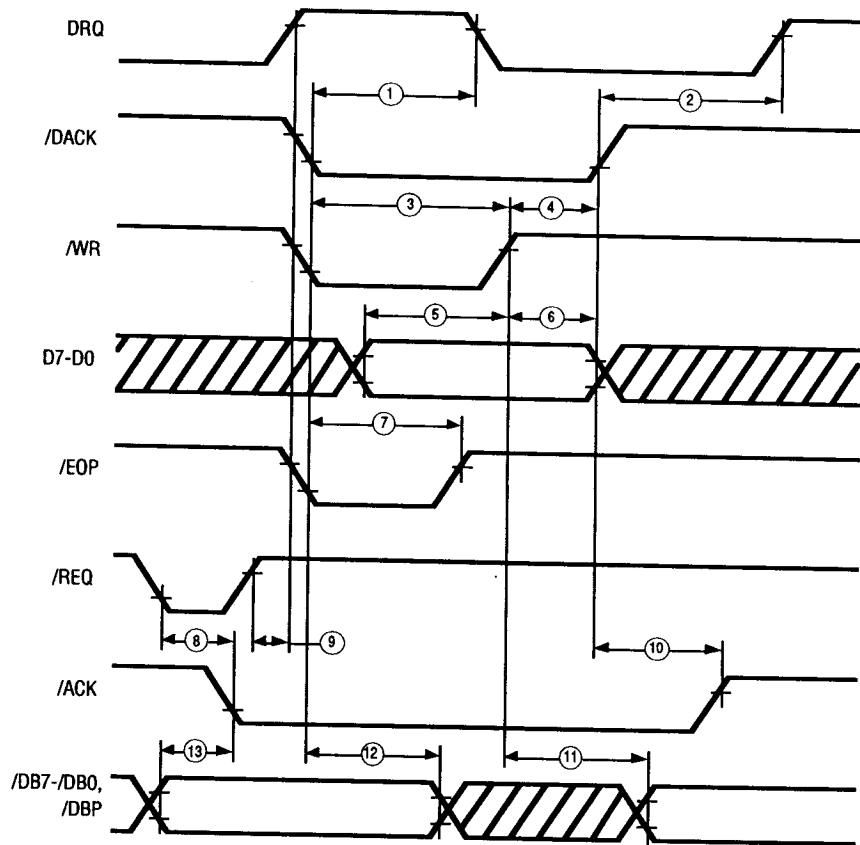

Figure 47. DMA Write (Non-Block Mode) Initiator Send Cycle

AC CHARACTERISTICS
DMA Write Initiator Send Cycle Table

No	Description	Min	Max	Units
1	DRQ Low from /DACK Low		60	ns
2	/DACK High to DRQ High	30		ns
3	Write Enable Width*	50		ns
4	/DACK Hold from End of /WR	0		ns
5	Data Setup to End of Write Enable*	50		ns
6	Data Hold Time from End of /WR	25		ns
7	Width of /EOP Pulse [1]	50		ns
8	/REQ Low to /ACK Low		70	ns
9	/REQ High to DRQ High		70	ns
10	/DACK High to /ACK High		90	ns
11	/WR High to Valid SCSI Data		50	ns
12	Data Hold from Write Enable*	15		ns
13	Data Setup to /ACK Low	55		ns

Notes:

[1] /EOP, /WR, and /DACK must be concurrently Low for at least T7 for proper recognition of the /EOP pulse.

* Write Enable is the occurrence of /WR and /DACK.

AC CHARACTERISTICS

DMA Read (Non-Block Mode) Initiator Receive Timing Diagram

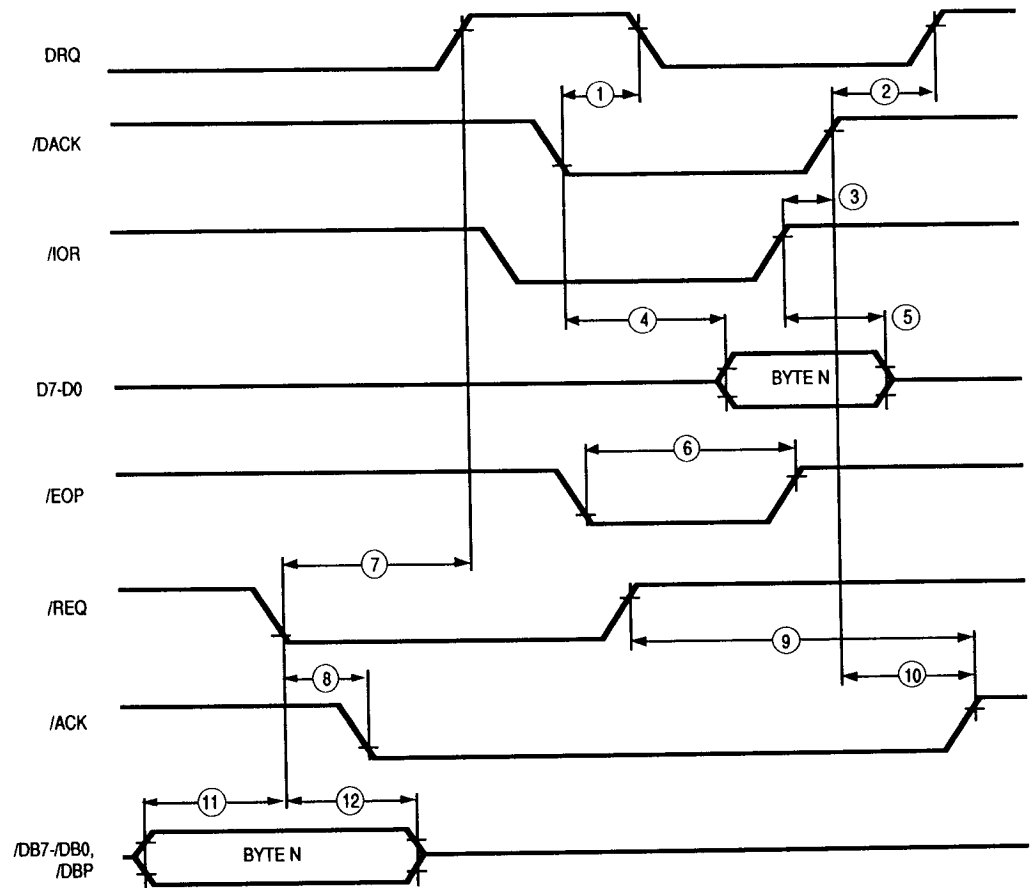

Figure 48. DMA Read (Non-Block Mode) Initiator Receive

AC CHARACTERISTICS

DMA Read (Non-Block Mode) Initiator Receive Table

Name	Description	Min	Max	Units
1	DRQ False from /DACK True		60	ns
2	/DACK False to DRQ True	30		ns
3	/DACK Hold Time from End of /IOR	0		ns
4	Data Access Time from Read Enable*		70	ns
5	Data Hold Time from End of /IOR	10		ns
6	Width of /EOP Pulse [1]	50		ns
7	/REQ True to DRQ True		70	ns
8	/REQ True to /ACK True		70	ns
9	/REQ False to /ACK False (/DACK False)		80	ns
10	/DACK False to /ACK False (/REQ False)		90	ns
11	DATA Setup Time to /REQ	20		ns
12	DATA Hold Time from /REQ True	50		ns

Notes:

[1] /EOP, /IOR and /DACK must be concurrently true for at least T6 for proper recognition of the /EOP pulse.

*Read enable is the occurrence of both /IOR and /DACK.

AC CHARACTERISTICS

DMA Write (Non-Block Mode) Target Send Cycle Timing Diagram

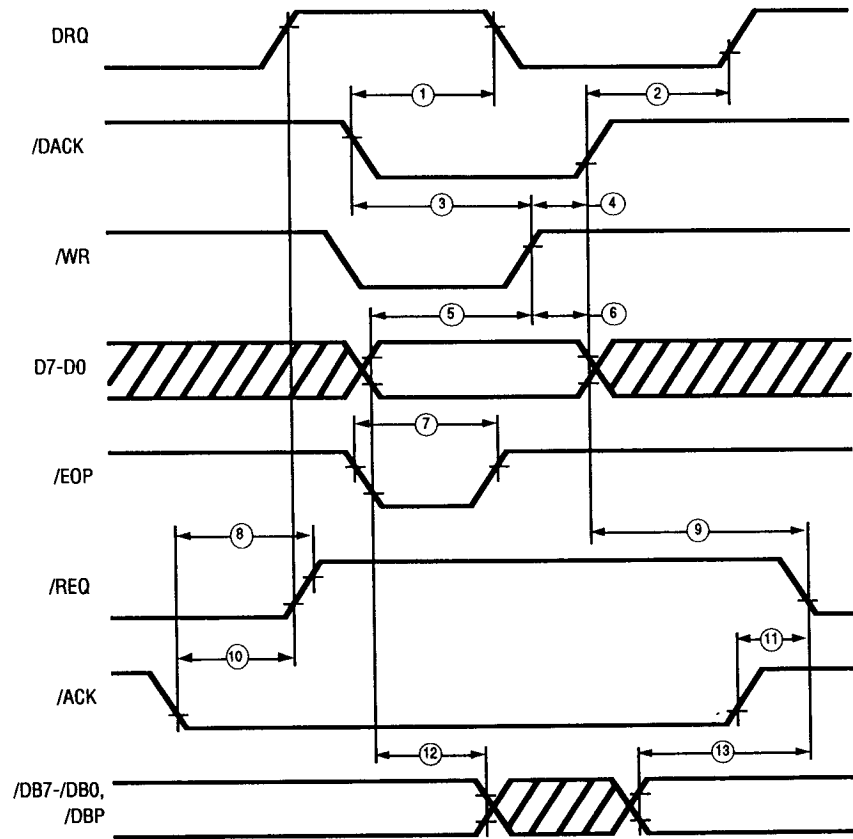

Figure 49. DMA Write (Non-Block Mode) Target Send Cycle

AC CHARACTERISTICS

DMA Write Target Send Cycle Table

No	Description	Min	Max	Units
1	DRQ Low from /DACK Low		60	ns
2	/DACK High to DRQ High	30		ns
3	Write Enable Width*	50		ns
4	/DACK Hold from /WR High	0		ns
5	Data Setup to End of Write Enable*	50		ns
6	Data Hold Time from End of /WR	25		ns
7	Width of /EOP Pulse [1]	50		ns
8	/ACK Low to /REQ High		80	ns
9	/REQ from End of /DACK (/ACK High)		90	ns
10	/ACK Low to DRQ High (Target)		70	ns
11	/ACK High to /REQ Low (/DACK High)		100	ns
12	Data Hold from Write Enable	15		ns
13	Data Setup to /REQ Low (Target)	55		ns

Notes:

[1] /EOP, /WR, and /DACK must be concurrently Low for at least T7 for proper recognition of the /EOP pulse.

* Write Enable is the occurrence of /IOW and /DACK

AC CHARACTERISTICS

DMA Read (Non-Block Mode) Target Receive Timing Diagram

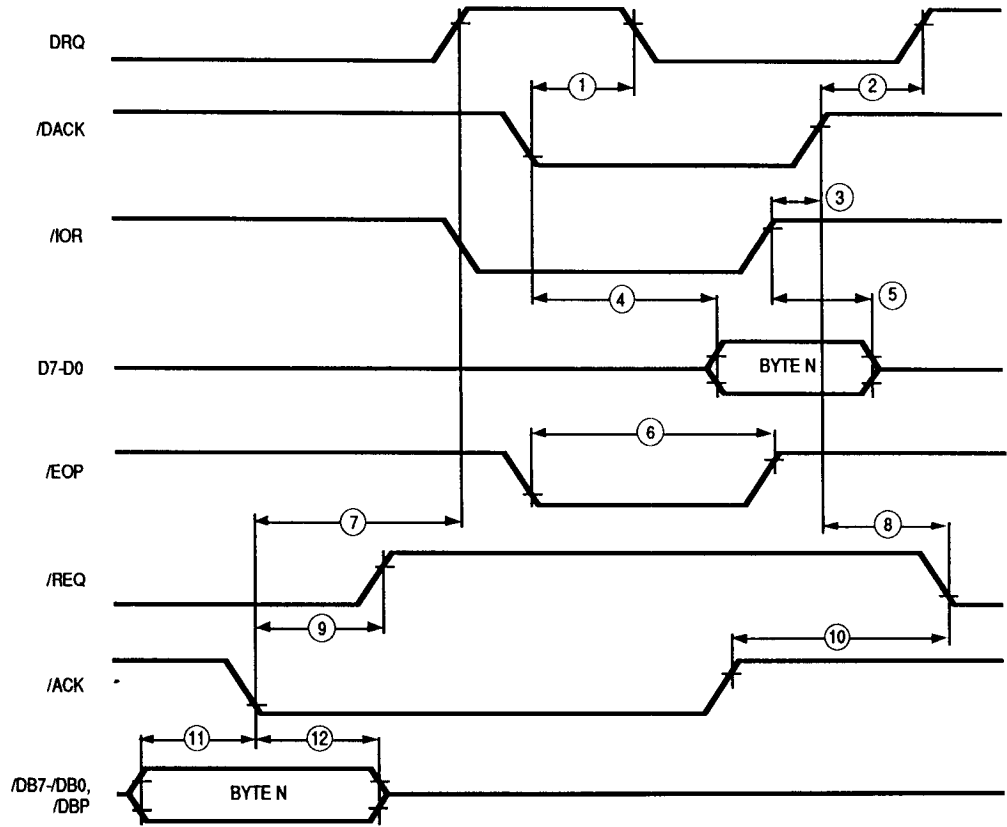

Figure 50. DMA Read (Non-Block Mode) Target Receive

AC CHARACTERISTICS

DMA Read (Non-Block Mode) Target Receive Table

Name	Description	Min	Max	Units
1	DRQ False from /DACK True		60	ns
2	/DACK False to DRQ True	30		ns
3	/DACK Hold Time from End of /IOR	0		ns
4	Data Access Time from Read Enable*		70	ns
5	Data Hold Time from End of /IOR	10		ns
6	Width of /EOP Pulse [1]	50		ns
7	/ACK True to DRQ True		70	
8	/DACK False to /REQ True (/ACK False)		90	
9	/ACK True to /REQ False		80	
10	/ACK False to /REQ True (/DACK False)		100	
11	DATA Setup Time to /ACK	20		
12	DATA Hold Time from /ACK True	30		

Notes:

[1] /EOP, /IOR and /DACK must be concurrently true for a least T6 for proper recognition of the /EOP pulse.

*Read enable is the occurrence of both /IOR and /DACK.

AC CHARACTERISTICS

DMA Write (Block Mode) Target Send Timing Diagram

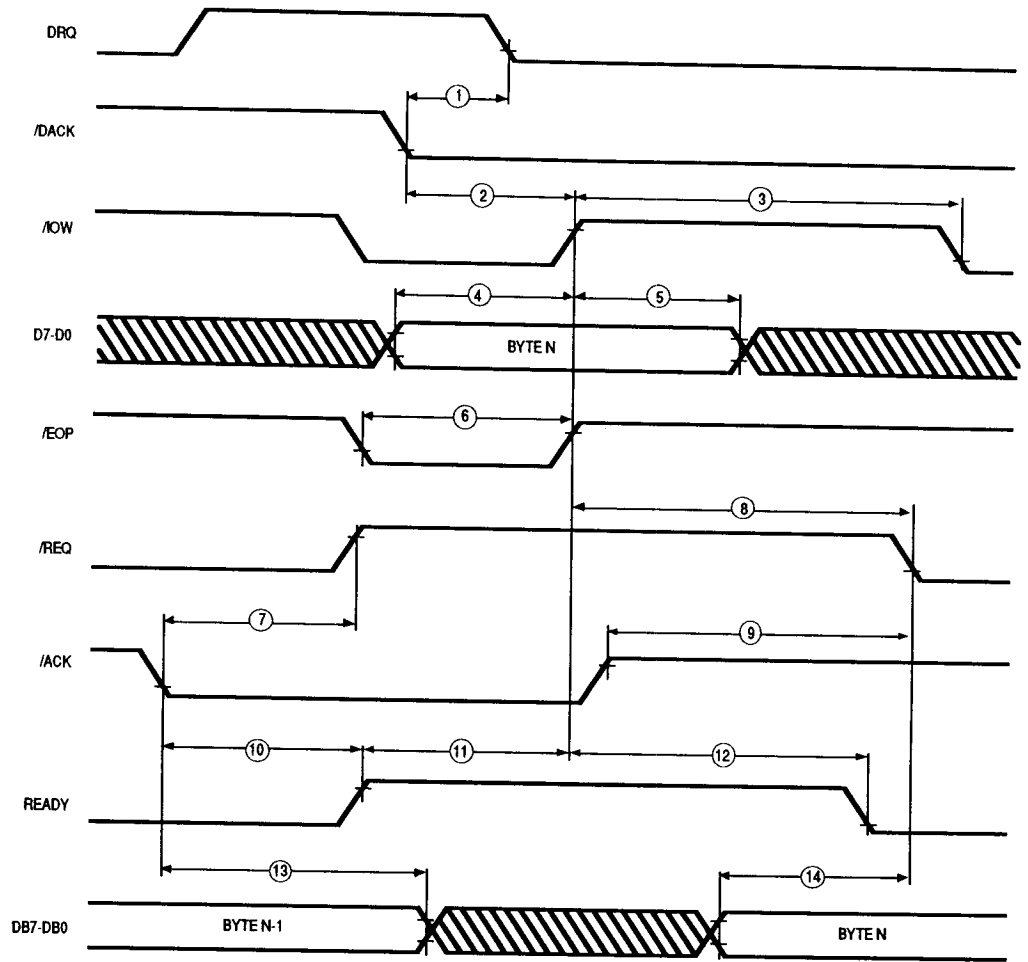

Figure 51. DMA Write (Block Mode) Target Send

AC CHARACTERISTICSDMA Write (Block Mode) Target Send Table

Name	Description	Min	Max	Units
1	DRQ False from /DACK True		60	ns
2	Write Enable Width*	50		ns
3	Write Recovery Time	120		ns
4	Data Setup to End of Write Enable*	50		ns
5	Data Hold Time from End of /IOW	25		ns
6	Width of /EOP Pulse [1]	50		ns
7	/ACK True to /REQ False		80	ns
8	/REQ from End of /IOW (/ACK False)		90	ns
9	/REQ from End of ACK (/IOW False)		100	ns
10	/ACK True to READY True		70	ns
11	READY True to /IOW False	70		ns
12	/IOW False to READY False		70	ns
13	DATA Hold from /ACK True	40		ns
14	Data Setup to /REQ True	55		ns

Notes:

[1] /EOP, /IOW, and /DACK must be concurrently true for at least T6 for proper recognition of the /EOP pulse.

*Read enable is the occurrence of both /IOR and /DACK.

AC CHARACTERISTICS

DMA Read (Block Mode) Target Receive Timing Diagram

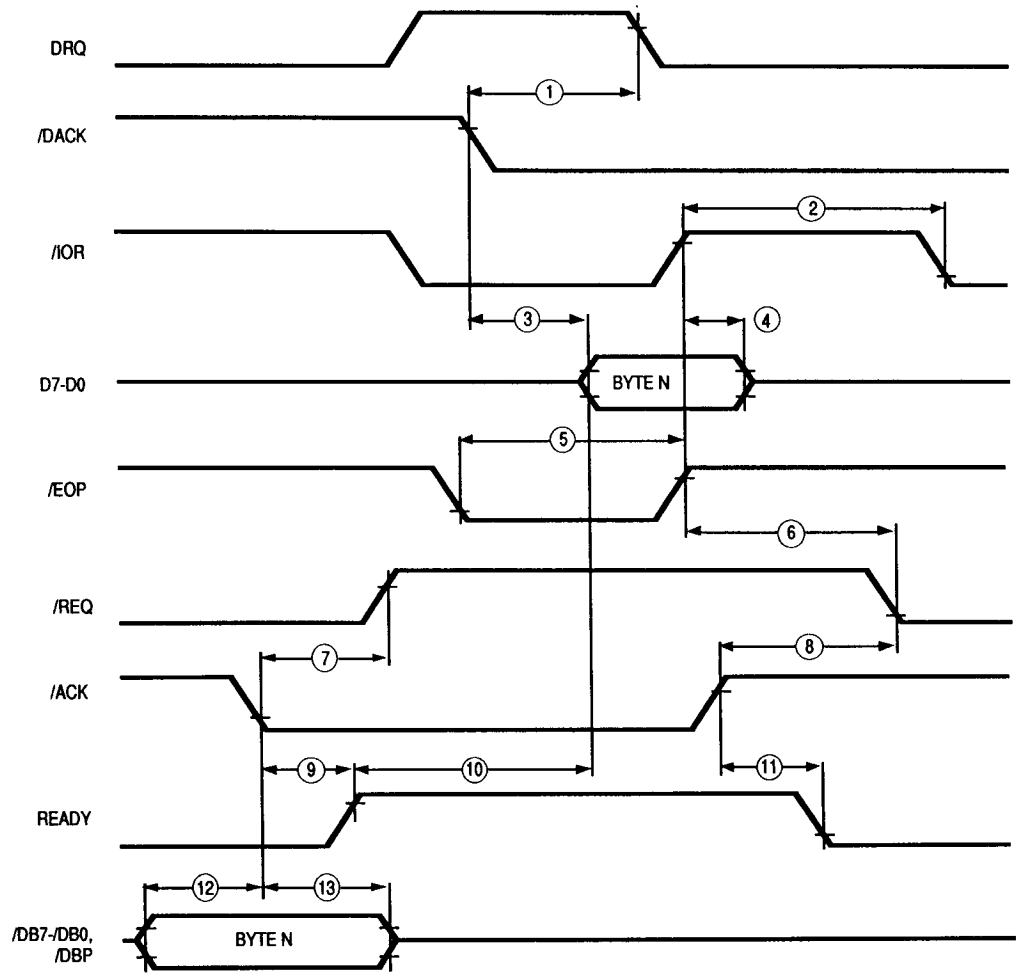

Figure 52. DMA Read (Block Mode) Target Receive

AC CHARACTERISTICS

DMA Read (Block Mode) Target Receive Table

Name	Description	Min	Max	Units
1	DRQ False from /DACK True		60	ns
2	/IOR Recovery Time	120		ns
3	Data Access Time from Read Enable*		70	ns
4	Data Hold Time from End of /IOR	10		
5	Width of /EOP Pulse [1]	50		ns
6	/IOR False to /REQ True (/ACK False)		90	ns
7	/ACK True to /REQ False		80	ns
8	/ACK False to /REQ True (/IOR False)		100	ns
9	/ACK True to READY True		70	ns
10	READY True to Valid Data		50	ns
11	/IOR False to READY False		70	ns
12	DATA Setup time to /ACK	20		
13	DATA Hold Time from /ACK	30		

Notes:

[1] /EOP, /IOR, and /DACK must be concurrently true for at least T5 for proper recognition of the /EOP pulse.

*Read enable is the occurrence of both /IOR and /DACK.

AC CHARACTERISTICS

Reset Timing Diagram

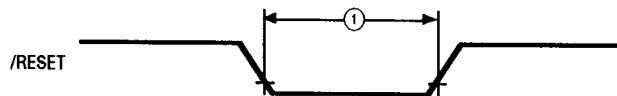

Figure 53. Reset

AC CHARACTERISTICS

Reset Table

No	Description	Min	Max	Units
1	Minimum Width of /RESET	100		ns

AC CHARACTERISTICS
Arbitration Timing Diagram

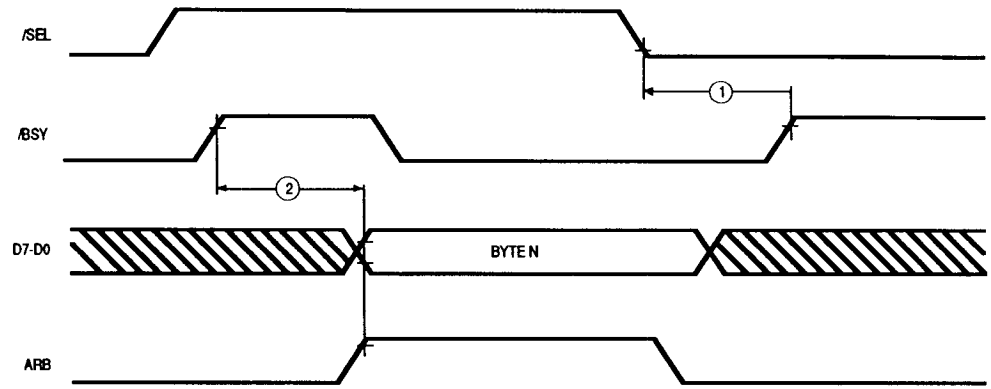
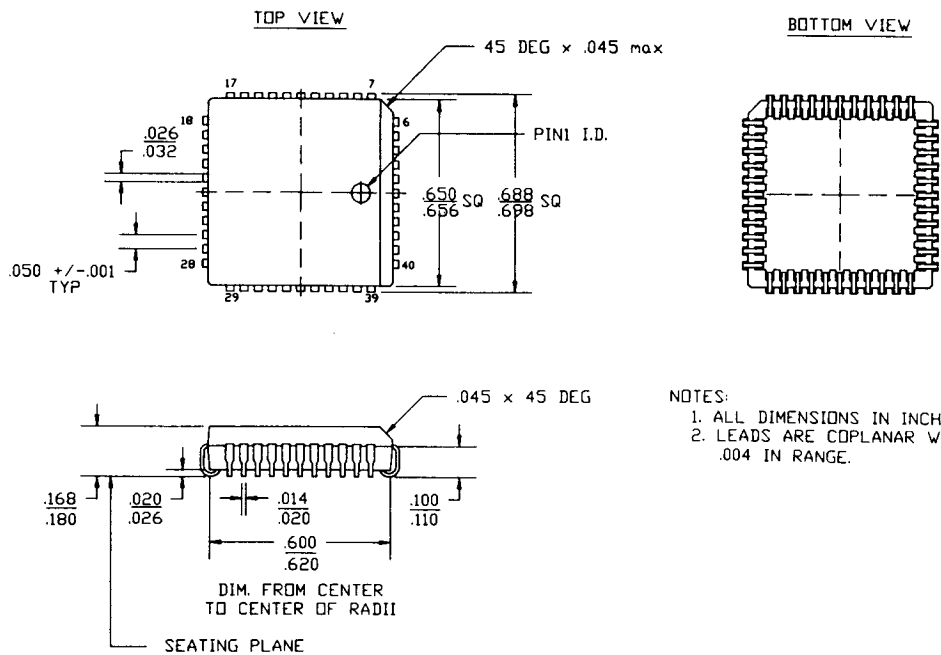

Figure 54. Arbitration

AC CHARACTERISTICS
Arbitration Table

Name	Description	Min	Max	Units
1	Bus Clear from SEL True		600	ns
2	ARBITRATE Start from BSY False	1200	2200	ns

PACKAGE INFORMATION



44-Pin PLCC Package Diagram

PACKAGE INFORMATION (Continued)

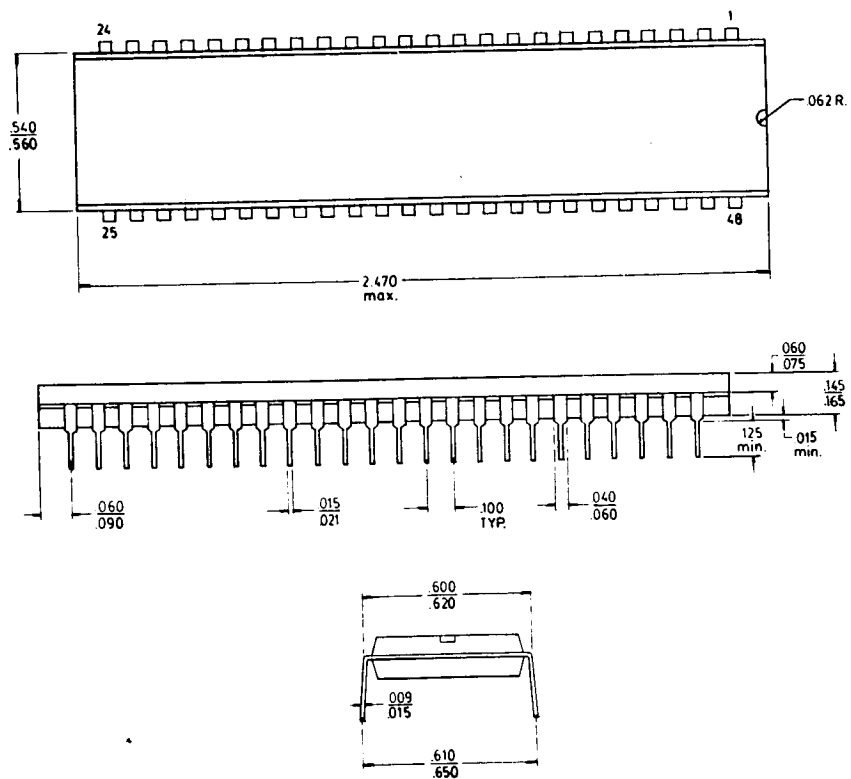

48-Pin DIP Package Diagram

ORDERING INFORMATION

Z53C80

48-Pin DIP	44-Pin PLCC
3 MBytes/sec	3 MBytes/sec
Z53C8003PSC	Z53C8003VSC

Package
P = Plastic
V = Plastic Chip Carrier

Environmental
C = Plastic Standard
E = Hermetic Standard

Temperature
S = 0°C to +70°C

Speed
3 = 3 MBytes per second

Example:

Z 53C80 03 V S C is a CMOS 53C80, 3 bytes per second, PLCC, 0°C to +70°C, Plastic Standard Flow.

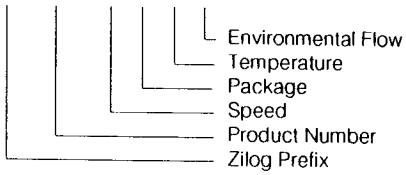

Looking for pricing, stock, or lifecycle information?

Click below to explore more details on WIN SOURCE:

 [View Z53C8003VSC on WIN SOURCE](#)

 [Zilog Information](#)

Optimize Your Supply Chain with WIN SOURCE Solutions

-  Global Sourcing Solution
-  Obsolete Management
-  Cost Control Management
-  Shortage Management
-  Alternative Solution
-  Excess Inventory Management