

DATA SHEET

ARRAY CHIP RESISTORS

YC 158/358 (10Pin/8R)

5%

sizes 0612/1225

RoHS compliant



SCOPE

This specification describes YC158/358 series chip resistor network with lead-free terminations made by thick film process.

APPLICATIONS

- Terminal for SDRAM and DDRAM
- Computer applications: laptop computer, desktop computer
- Consume electronic equipment: PDAs, PNDs
- Mobile phone, telecom...

FEATURES

- RoHS compliant
 - Products with lead free terminations meet RoHS requirements
 - Pb-glass contained in electrodes
 - Resistor element and glass are exempted by RoHS
- Reducing environmentally hazardous wastes
- High component and equipment reliability
- Saving of PCB space
- None forbidden-materials used in products/production
- Halogen Free Epoxy

ORDERING INFORMATION - GLOBAL PART NUMBER & I2NC

Both part numbers are identified by the series, size, tolerance, packing type, temperature coefficient, taping reel and resistance value.

YAGEO BRAND ordering code

GLOBAL PART NUMBER (PREFERRED)

YC 158/358 X X X X XX XXXX L
 (1) (2) (3) (4) (5) (6) (7)

(1) SCHEMATIC

L = L-type (for YC358)
 T = T-type (for YC158/358)

(2) TOLERANCE

J = ±5%

(3) PACKAGING TYPE

R = Paper taping reel (YC158)
 K = Embossed taping reel (YC358)

(4) TEMPERATURE COEFFICIENT OF RESISTANCE

- = Base on spec

(5) TAPING REEL

07 = 7 inch dia. Reel
 13 = 13 inch dia. Reel

(6) RESISTANCE VALUE

There are 2~4 digits indicated the resistor value. Letter R/K/M is decimal point, no need to mention the last zero after R/K/M, e.g.1K2, not 1K20.
 Detailed resistance rules show in table of "Resistance rule of global part number".

(7) OPTIONAL CODE

L = optional symbol (Note)

Resistance rule of global part number	
Resistance code rule	Example
XRXX (1 to 9.76 Ω)	1R = 1 Ω 1R5 = 1.5 Ω 9R76 = 9.76 Ω
XXRX (10 to 97.6 Ω)	10R = 10 Ω 97R6 = 97.6 Ω
XXXR (100 to 976 Ω)	100R = 100 Ω
XKXX (1 to 9.76 KΩ)	1K = 1,000 Ω 9K76 = 9760 Ω
XMXX (1 to 9.76 MΩ)	1M = 1,000,000 Ω 9M76 = 9,760,000 Ω

ORDERING EXAMPLE

The ordering code of a YC158/358T T-type chip resistor network, value 1,000 Ω with ±5% tolerance, supplied in 7-inch tape reel is: YC158/358TJR-071K(L).

NOTE

1. All our RSMD products meet RoHS compliant. "LFP" of the internal 2D reel label mentions "Lead Free Process"
2. On customized label, "LFP" or specific symbol printed and the optional "L" at the end of GLOBAL PART NUMBER / I2NC can be added (both are on customer request)

PHYCOMP BRAND ordering codes

Both GLOBAL PART NUMBER (preferred) and I2NC (traditional) codes are acceptable to order Phycomp brand products.

GLOBAL PART NUMBER (PREFERRED)

For detailed information of GLOBAL PART NUMBER and ordering example, please refer to page 2.

I2NC CODE----

2350 **XXX XXXXX L**
 (1) (2) (3) (4)

SIZE	TYPE	START IN ⁽¹⁾	TOL. (%)	RESISTANCE RANGE	PAPER / PE TAPE ON REEL (units) ⁽²⁾		EMBOSSED TAPE ON REEL(units) ⁽²⁾
					5,000	20,000	4,000
0612	RNA310	2350	±5%	10 to 100 KΩ	230 10xxx	230 12xxx	
1225	YC358L	2350	±5%	10 to 330 KΩ			200 10xxx
1225	YC358T	2350	±5%	10 to 330 KΩ			201 10xxx

- (1) The resistors have a 12-digit ordering code starting with 2350.
- (2) The subsequent 4 or 5 digits indicate the resistor tolerance and packaging.
- (3) The remaining 4 or 3 digits represent the resistance value with the last digit indicating the multiplier as shown in the table of "Last digit of I2NC".
- (4) "L" is optional symbol ^(Note).

Resistance decade ⁽³⁾	Last digit
0.01 to 0.0976 Ω	0
0.1 to 0.976 Ω	7
1 to 9.76 Ω	8
10 to 97.6 Ω	9
100 to 976 Ω	1
1 to 9.76 KΩ	2
10 to 97.6 KΩ	3
100 to 976 KΩ	4
1 to 9.76 MΩ	5
10 to 97.6 MΩ	6

ORDERING EXAMPLE

The ordering code of a RNA310/YC358T T-type chip resistor network, value 1,000 Ω with ±5% tolerance, supplied in tape of 10,000 units per reel is: 235023010102(L) / 235020110102(L) or YC158/358TJR-071K (L).

NOTE

- 1. All our RSMD products are RoHS compliant. "LFP" of the internal 2D reel label mentions "Lead Free Process"
- 2. On customized label, "LFP" or specific symbol printed and the optional "L" at the end of GLOBAL PART NUMBER / I2NC can be added (both are on customer request)

Example:

0.02 Ω	=	0200 or 200
0.3 Ω	=	3007 or 307
1 Ω	=	1008 or 108
33 KΩ	=	3303 or 333
10 MΩ	=	1006 or 106

MARKING

YC158

YC358

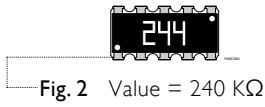
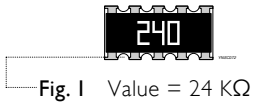

E-24 series: 3 digits

First two digits for significant figure and 3rd digit for number of zeros

For further marking information, please see special data sheet “Chip resistors marking”.

CONSTRUCTION

The resistor is constructed on top of a high-grade ceramic body. Internal metal electrodes are added on each end to make the contacts to the thick film resistive element. The composition of the resistive element is a noble metal imbedded into a glass and covered by a second glass to prevent environment influences. The resistor is laser trimmed to the rated resistance value. The resistor is covered with a protective epoxy coat, finally the two external terminations (matte tin on Ni-barrier) are added. See fig.3

OUTLINES

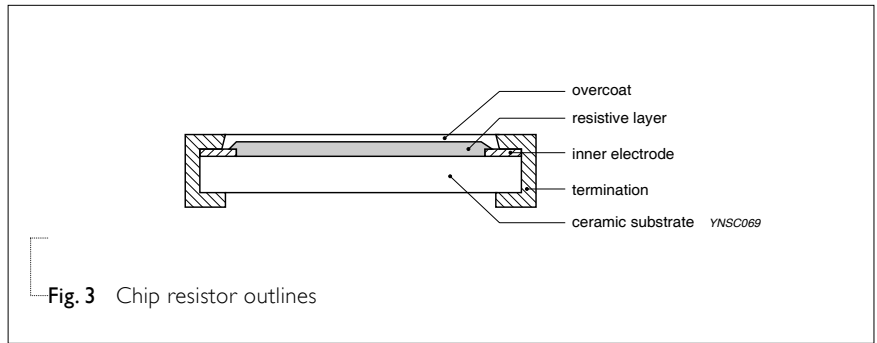

DIMENSIONS

Table I

TYPE	YC158	YC358
B (mm)	0.30 ±0.15	0.50 ±0.15
H (mm)	0.45 ±0.05	1.10 ±0.15
P (mm)	0.64 ±0.05	1.27 ±0.05
L (mm)	3.20 ±0.20	6.40 ±0.20
T (mm)	0.60 ±0.10	0.60 ±0.10
W ₁ (mm)	0.35 ±0.15	0.50 ±0.15
W ₂ (mm)	1.60 ±0.15	3.20 ±0.20

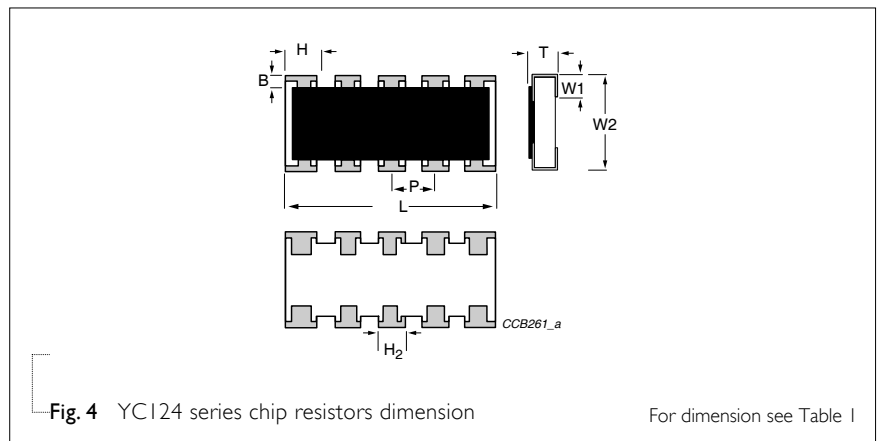

SCHEMATIC

For dimension see Fig. 4 and Table I

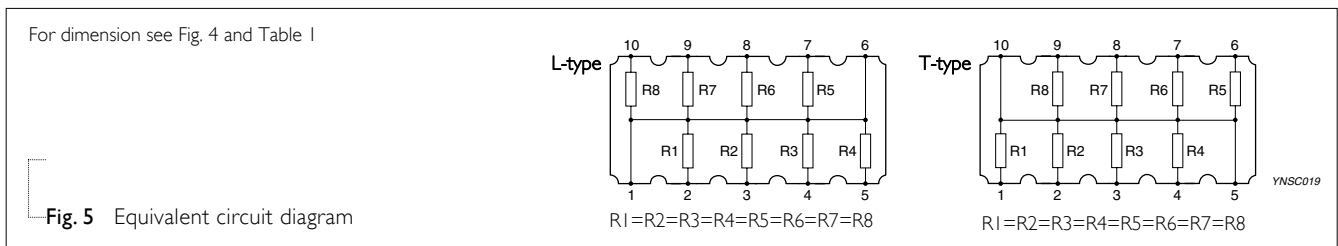

ELECTRICAL CHARACTERISTICS

Table 2

CHARACTERISTICS	YC158 1/16 W	YC358 1/16 W
Operating Temperature Range	-55 °C to +155 °C	-55 °C to +155 °C
Maximum Working Voltage	25 V	50 V
Maximum Overload Voltage	50 V	100 V
Dielectric Withstanding Voltage	50 V	100 V
Resistance Range	5% (E24) 10 Ω to 100 KΩ	10 Ω to 330 KΩ
Temperature Coefficient	±200 ppm/°C	±200 ppm/°C

FOOTPRINT AND SOLDERING PROFILES

For recommended footprint and soldering profiles, please see the special data sheet “Chip resistors mounting”.

PACKING STYLE AND PACKAGING QUANTITY

Table 3 Packing style and packaging quantity

PACKING STYLE	REEL DIMENSION	YC158	YC358
Paper/PE taping reel (R)	7" (178 mm)	5,000	---
	13" (330 mm)	20,000	---
Embossed taping reel (K)	7" (178 mm)	---	4,000

NOTE

I. For Paper/Embossed tape and reel specification/dimensions, please see the special data sheet “Chip resistors packing”.

FUNCTIONAL DESCRIPTION

POWER RATING

YC158/358 rated power at 70 °C is 1/16 W

RATED VOLTAGE

The DC or AC (rms) continuous working voltage corresponding to the rated power is determined by the following formula:

$$V = \sqrt{P \times R}$$

or max. working voltage whichever is less

Where

V=Continuous rated DC or AC (rms) working voltage (V)

P=Rated power (W)

R=Resistance value (Ω)

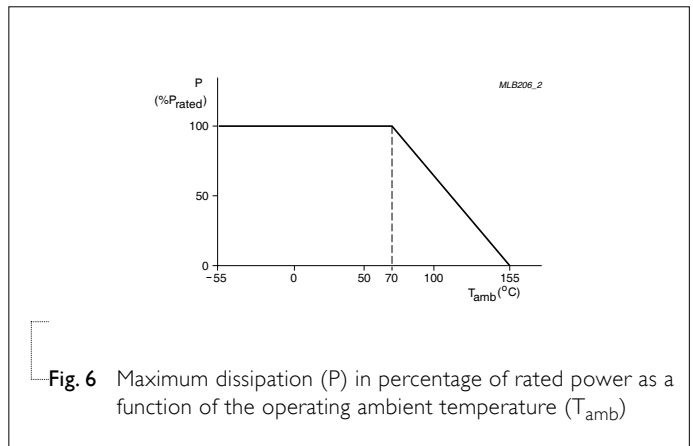

Fig. 6 Maximum dissipation (P) in percentage of rated power as a function of the operating ambient temperature (T_{amb})

TESTS AND REQUIREMENTS
Table 4 Test condition, procedure and requirements

TEST	TEST METHOD	PROCEDURE	REQUIREMENTS
Life/ Operational Life/ Endurance	MIL-STD-202G-method 108A	1,000 hours at 70±5 °C applied RCWV	±(2%+0.05 Ω)
	IEC 60115-1 4.25.1	1.5 hours on, 0.5 hour off, still air required	
	JIS C 5202-7.10		
High Temperature Exposure/ Endurance at upper category temperature	MIL-STD-202G-method 108A	1,000 hours at maximum operating temperature	±(1%+0.05 Ω)
	IEC 60115-1 4.25.3	depending on specification, unpowered	
	JIS C 5202-7.11	No direct impingement of forced air to the parts Tolerances: 155±3 °C	
Moisture Resistance	MIL-STD-202G-method 106F	Each temperature / humidity cycle is defined at 8 hours (method 106F), 3 cycles / 24 hours for 10d with 25 °C / 65 °C 95% R.H, without steps 7a & 7b, unpowered Parts mounted on test-boards, without condensation on parts Measurement at 24±2 hours after test conclusion	±(2%+0.05 Ω)
	IEC 60115-1 4.24.2		
Thermal Shock	MIL-STD-202G-method 107G	-55/+155 °C	±(0.5%+0.05 Ω) for 10 KΩ to 10 MΩ
		Note: Number of cycles required is 300. Devices unmounted Maximum transfer time is 20 seconds. Dwell time is 15 minutes. Air – Air	±(1%+0.05 Ω) for others
Short time overload	MIL-R-55342D-para 4.7.5	2.5 times RCWV or maximum overload voltage whichever is less for 5 sec at room temperature	±(2%+0.05 Ω)
	IEC60115-1 4.13		No visible damage
Board Flex/ Bending	IEC60115-1 4.33	Device mounted on PCB test board as described, only 1 board bending required	±(1%+0.05 Ω)
		3 mm bending Bending time: 60±5 seconds Ohmic value checked during bending	No visible damage

TEST	TEST METHOD	PROCEDURE	REQUIREMENTS
Solderability - Wetting	IPC/JEDECJ-STD-002B test B IEC 60068-2-58	Electrical Test not required Magnification 50X SMD conditions: 1 st step: method B, aging 4 hours at 155 °C dry heat 2 nd step: leadfree solder bath at 245±3 °C Dipping time: 3±0.5 seconds	Well tinned (≥95% covered) No visible damage
- Leaching	IPC/JEDECJ-STD-002B test D IEC 60068-2-58	Leadfree solder, 260 °C, 30 seconds immersion time	No visible damage
- Resistance to Soldering Heat	MIL-STD-202G-method 210F IEC 60068-2-58	Condition B, no pre-heat of samples Leadfree solder, 270 °C, 10 seconds immersion time Procedure 2 for SMD: devices fluxed and cleaned with isopropanol	±(1%+0.05 Ω) No visible damage

REVISION HISTORY

REVISION	DATE	CHANGE NOTIFICATION	DESCRIPTION
Version 3	Nov 14, 2008	-	<ul style="list-style-type: none">- New datasheet for YC158 and YC358 thick film 5% with lead-free terminations- Replace the YC158 and YC358 part of pdf files: Pu-YC158_5_PbFree_L_2.pdf, Yu-YC158_5_PbFree_L_2.pdf, Pu-YC358_5_PbFree_L_0.pdf and Yu-YC358_5_PbFree_L_0.pdf- Description of "Halogen Free Epoxy" added- Define global part number
Version 2	Feb 22, 2005	-	<ul style="list-style-type: none">- Test method and procedure updated
Version 1	Apr. 22, 2004	-	<ul style="list-style-type: none">- Added 13" taping and Jumper, deleted G in ordering code, and test & requirement (Pb free) update
Version 0	Nov. 10, 2003	-	<ul style="list-style-type: none">- First issue of this specification

"Yageo reserves all the rights for revising the content of this datasheet without further notification, as long as the products itself are unchanged. Any product change will be announced by PCN."

Looking for pricing, stock, or lifecycle information?

Click below to explore more details on WIN SOURCE:

-  [View YC358LJK-07102 on WIN SOURCE](#)
-  [Yageo Information](#)

Optimize Your Supply Chain with WIN SOURCE Solutions

-  Global Sourcing Solution
-  Obsolete Management
-  Cost Control Management
-  Shortage Management
-  Alternative Solution
-  Excess Inventory Management