



**THE DATASHEET OF
XRT94L43IB-F**



GENERAL DESCRIPTION

The XRT94L43 is an SDH to PDH physical layer processor with integrated SONET OC-12 and 12 DS3/E3 framing controller. The XRT94L43 contains an integral SONET framer which provides framing and error accumulation in accordance with ANSI/ITU-T specifications. For a multiple channel DS3/E3 feature, each channel contains identical elements. The configuration of this device is through internal registers accessible via an 8-bit parallel, memory mapped, microprocessor interface.

The SONET/SDH transmit and receive blocks are used to transmit/receive an STS-12/STM-4 signals or compose and decompose 12, STS-1/DS3/E3 signals. The blocks operate at a peak internal clock speed of 77 MHz and support 8-bit internal data paths. The transmit and receive blocks are compliant with both SONET and SDH standards.

The XRT94L43 performs all SONET transport and path overhead processing for use in broadband data transport applications.

FEATURES

- Single Chip solution for 12 DS3/E3 to SONET/SDH Mapping
- Generates and terminates SONET section, line and path layers.
- Provides SONET frame scrambling and descrambling.
- Differential Line Interfaces
- 8-bit microprocessor interface
- Requires +2.5 and +3.3V power supplies with +5V input tolerance
- -40°C to +85°C Operating Temperature Range
- Available in a 516 Ball PBGA package

APPLICATIONS

- Network switches
- Concentrators
- Frame Relay Switches
- SONET Customer Premises Multiplexers
- Network Access Equipment
- Test/Monitoring Equipment

FIGURE 1. BLOCK DIAGRAM OF THE XRT94L43 WHEN CONFIGURED IN SONET MODE

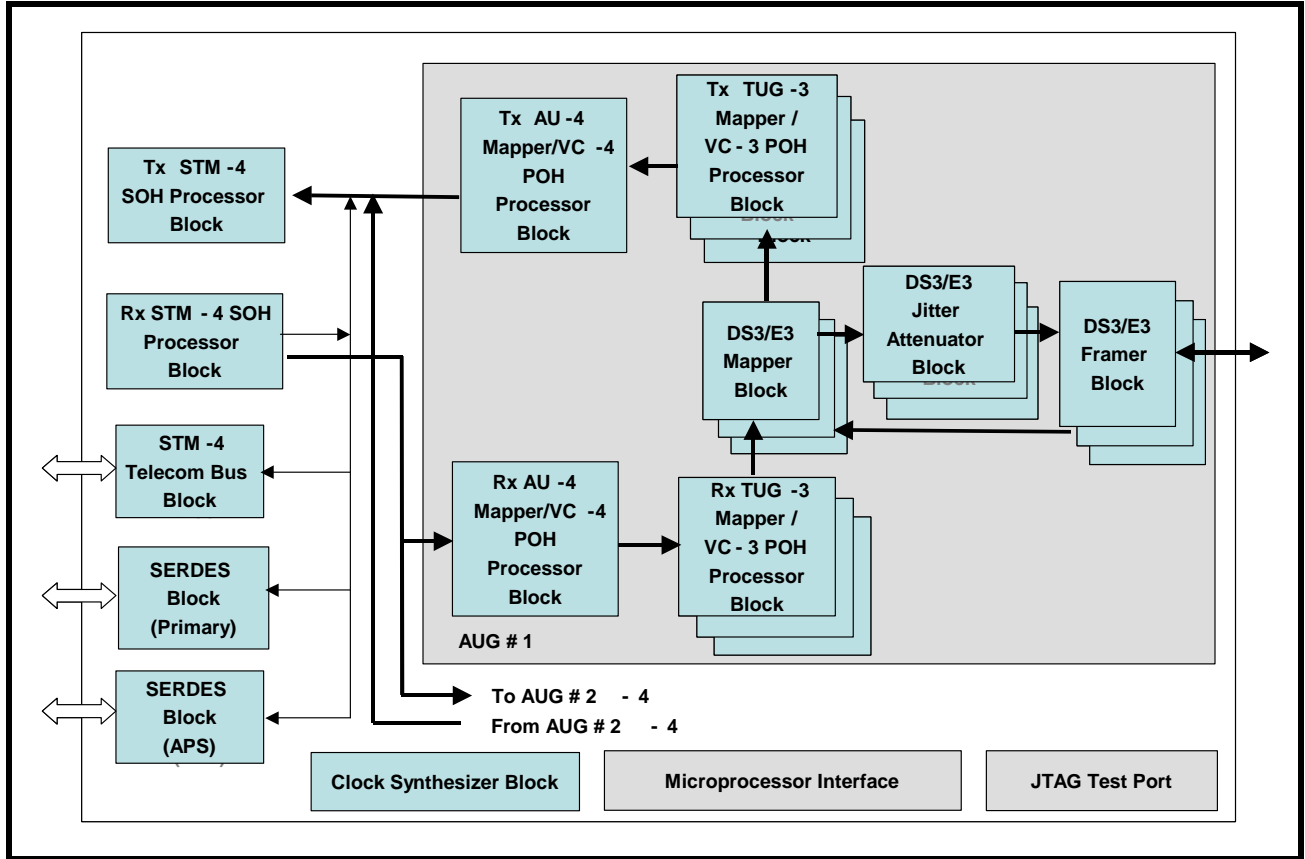

FIGURE 2. BLOCK DIAGRAM OF THE XRT94L43 WHEN CONFIGURED IN SDH/TUG-3 MODE

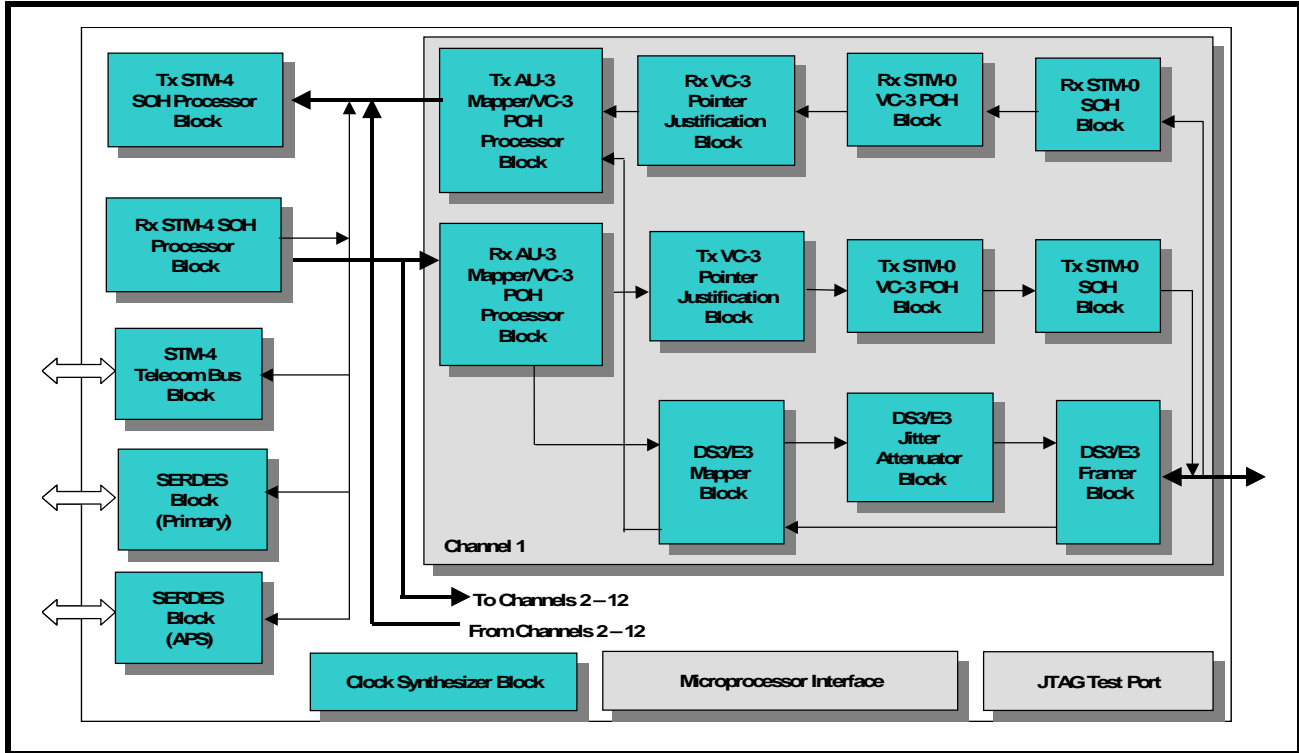
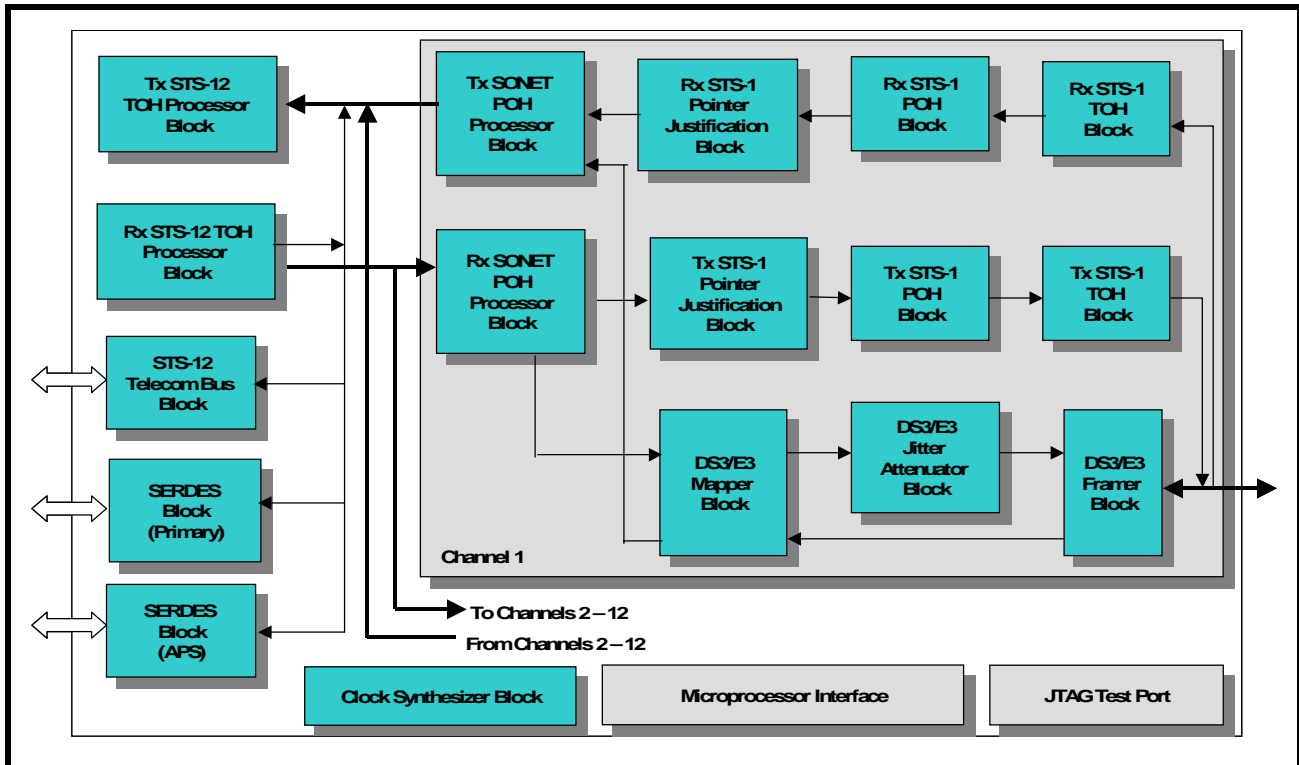

FIGURE 3. BLOCK DIAGRAM OF THE XRT94L43 WHEN CONFIGURED IN SDH/AU-3 MODE



PRODUCT FEATURES

SONET TRANSMITTER

- Generates and Transmits Standard STS-12/STM-4 data
- Generates and Transmits either an STM-4/TUG-3 or STM-4/AU-3 signals for SDH applications
- Conforms to ITU-T 1.432, ANSI T1.105 and Bellcore GR-253 Standards
- Performs SONET frame insertion and accepts external frame synchronization
- Performs Optional Transmit Data Scrambling
- Permits the user to externally insert their own values for the POH and TOH into the outbound STS-12/STM-4 traffic
- Generates transmit payload pointer (H1,H2) (fixed at 522) with NDF insertion
- Inserts A1/A2 with optional error mask
- Computes and inserts BIP-8 (B1,B2) with optional error mask
- Generates and transmits REI-L and RDI-L either upon Software Command or automatically based upon errors and defects that are detected/declared by the SONET Receiver.
- Permits the user to transmit the LOS pattern via Software Command.
- Generates and transmits RDI-P and REI-P either upon Software Command or automatically based upon errors and defects that are detected/declared by the SONET Receiver.
- Inserts the fixed-stuff columns, calculates and inserts the B3 byte value into each outbound STS-1 SPE/VC-3 or STS-3c SPE/VC-4

SONET RECEIVER

- Receives and processes standard STS-12/STM-4 signals
- Receives and processes either an STM-4/TUG-3 or STM-4/AU-3 signal for SDH Applications
- Permits the user to fully program the B2 Byte Error-rate thresholds for declaration and clearance of the SD and SF defect conditions
- Provides section trace buffer with mismatch detection and invalid message detection
- Performs SONET Frame Synchronization
- Supports NDF, positive stuff and negative stuff for pointer processor
- Performs receive data de-scrambling
- Performs POH and TOH interpretation/extraction
- Interprets payload pointer (H1,H2)
- Extracts data communication channels from D1-D3 and D4-D12
- Declares and Clears the SEF (Severely Erred Frame), LOF (Loss of Frame) and LOS (Loss of Signal) defect conditions
- Declares and clears the Line AIS (AIS-L) and the Line Remote Defect Indicator (RDI-L) defect conditions
- Declares and Clears the Path - AIS (AIS-P), Loss of Pointer (LOP-P) and Path - Unequipped (UNEQ-P) defect conditions.
- Supports either the Single-Bit or Extended form of RDI-P
- Monitors the Path Signal Label and declares/clears the PLM-P defect condition

SONET/SDH OC-12 TO 12XDS3/E3 MAPPER

- Contains 12 on-chip 64 byte Expected Receive Path Trace Message Buffer, in which the user will load in an expected Path Trace Message
- Contains 12 on-chip 64 byte Actual" Receive Path Trace Message Buffers, that will contain the actual Received Path Trace Message
- The SONET Receiver will use the contents within both the Expected and Actual Receive Path Trace Message Buffers to either declare or clear the TIM-P defect condition
- Computes and verifies the B3 bytes within each incoming STS-1 SPE/VC-3 or STS-3c SPE/VC-4 and increments on-chip Performance Monitoring registers each time it detects B3 byte errors.
- Detects and Flags Line - Remote Error Indicator (REI-L) and Path - Remote Error Indicator (REI-P) events, and increments on-chip Performance Monitoring registers each time it detects REI-L or REI-P events
- Computes and verifies both the B1 and B2 bytes within the incoming STS-12/STM-4 data-stream and increments on-chip Performance Monitoring registers each time it detects B1 or B2 byte errors

MAPPER

- Maps DS3 data into/De-maps DS3 data from an STS-1 SPE per the requirements in Telcordia GR-253-CORE
- Maps DS3/E3 data into/De-Maps DS3/E3 data from a VC-3 per ITU-T G.707
- Implements AU-3 to VC-3 multiplexing and de-multiplexing

DS3 RECEIVE FRAMER

- Offers off-line framing algorithm
- Complies with the standards as: Bellcore TR-NWT-000499 and TR-NWT-000009
- Supports overhead extraction
- Detects and flags LCV (Line Code Violations) and EXZ (Excessive Zero Events).
- Reports and counts FEBE
- HDLC controller complies with ITU-T Q.921 LAPD protocol
- Provides Line and Local Loop-backs
- Supports either the M13 or the C-bit Parity Framing formats
- Supports B3ZS line decoding which can be user enabled.Replaces valid B0V or 00V with 3 zeros
- Synchronizes to incoming frame based upon 10 valid F bits followed by 3 consecutive valid M frames, Offers optional AIC-bit or parity verification before declaration of sync
- Detects Out of Frame (OOF) upon 3 or 6 F bits out of 15 F bits in error or 1 or more M bits in 3 of 4 consecutive frames in error
- Detects Loss of Signal (LOS) upon encountering 180 consecutive 0's and clears on at least 60 of successive received 1's.Offers optional disable
- Detects idle state by checking C-bit in subframe 3 are all zero, X-bits are one and repeating 11001100 payloads. Declaration occurs when all the above conditions persist for 63 M-frames. Clears the condition when 63 valid M-frames are received
- Detects AIS with different algorithm
- Computes and verifies P and CP-Bits
- Validate FERF bits, sets to one when both X-bits are zero and clears when they are One
- Detects and validates FEAC codes upon 8 out of 10 last identical received codes.Invalidates on 3 in 10 mismatch

- Provides 15-bit PRBS lock

DS3 TRANSMIT FRAMER

- Offers following frame generation mechanism: Asynchronous operation, using receive side clock, external framing
- Supports either C-bit operation or M13 operation: optional all C bits set to "1" or C-bit parity ID bit (C11) toggled in each frame for M13 operation
- Provides start of frame control with external pin
- Inserts frame overhead bits via External serial port or Internal generation
- Generates and checks parity
- Automatically transmits the DS3 FERF/REI indicator whenever the DS3 Receiver declares either the DS3 LOS, DS3 AIS or DS3 OOF defect conditions.
- Permits the user to control the DS3 FEBE/REI bit-fields via Software Control, or to automatically transmit the FEBE/REI indicator whenever the DS3 Receiver detects CP-Bit or Framing (F or M) bit errors
- Provides FEAC channel processing including generation of valid FEAC patterns and transmissions of all 1's upon programming of idle code
- Inserts path maintenance data link through HDLC transmitter which contains the following features:
 - AM for storage of entire LAPD message
 - Selection of message length to 82 or 76 bytes
 - Optional frame header generation
 - Generation of flag sequences
 - Computation and insertion of CRC
 - Zero stuffing
 - Register bits for communication with microprocessor
 - Interrupt generation upon transmission of message
- LOS Insertion enabled by register bit
- AIS Insertion enabled by register bit or pin
- Idle signal insertion enabled by register bit
- Supports B3ZS encoding
- Generates AIS, Idle and Yellow force alarms
- Inserts errors optionally in the P, F, FEBE and M bits
- Provides 15-bit PRBS generator

E3 RECEIVE FRAMER

- Offers off-line framing algorithm
- Complies with standards as: ITU-T G.751 and G.832
- Provides line code violation detection and excess zero count
- LAPD controller complies with ITU Q.921 LAPD protocol
- Provides local loop-back
- Supports G.751 and G.832 framing formats
- Supports HDB3 line decoding which can be user enabled. Replaces valid B00V or 000V with 4 zero's

XRT94L43

SONET/SDH OC-12 TO 12XDS3/E3 MAPPER

- Synchronizes to incoming frame based upon occurrence of two sets of FA1, FA2 with expected separation - G.832 or detection of three consecutive frame alignment signals (FAS) - G.751
- Detects Out of Frame (OOF) upon 4 consecutive invalid frames
- Detects Loss of Signal (LOS) upon encountering 32 consecutive 0's and clears on occurrence of 32 bits without a string of 4 0s
- Detects AIS if 7 or less 0s detected in each of 2 consecutive frames and clears if more than seven 0's detected in each of 2 consecutive frames
- Calculation and comparison of BIP-8 (G.832) or BIP-4 (G.751). BIP-4 calculation can be disabled
- Supports overhead extraction
- Microprocessor access to TR trail trace message - 16 TTB registers (G.832) or service (Alarm and Nation) bits (G.751)
- Detects MA FERF if 3 or 5 consecutive MA MSBs are 1 and clears if 3 or 5 consecutive MA MSBs are 0 (only E3 G.832)
- Indicates last validated FERF value and interrupt upon a change in validated FERF value
- Extracts payload type (MA) bits and stores in a register (Only E3 G.832)
- Extracts Timing Marker bit and checks for consistency over 3 or 5 consecutive frames (only E3 G.832)
- Extracts Synchronous Status Message bits and stores it in register bits when enabled (only G.832)
- Overhead output on synchronous serial interface

E3 TRANSMIT FRAMER

- Offers following frame generation mechanism: Asynchronous operation, using receive side clock, external framing
 - Supports either G.751 or G.832 framing format
 - Generates and checks parity BIP-8 (G.832), BIP-4 (G.751) BIP-4 computation can be disabled
 - Inserts data link message through E3 data line channel which contains the following features:
 - Insertion into NR or GC byte (programmable through register bit) (E3 G.832 only)
 - Insertion into Nation bit in case of E3 G.751 when LAPD is enabled
 - RAM storage of entire LAPD message
 - Selection of message length to 82 or 76 bytes
 - Generation of flag sequences
 - Computation and insertion of CRC-16
 - Zero stuffing
 - Register bits for communication with microprocessors
 - Interrupt generation upon complete transmission of message
 - LOS insertion enabled by register bit to force all 0s in the transmit stream
 - AIS insertion enabled by register bit and/or pin to force all 1's in the transmit stream
 - Supports HDB3 encoding enabled by register bit
 - Inserts frame overhead bits via External serial/nibble port (except for FA1,FA2 and EM bytes in case of E3 G.832 and FAS and BIP-4 in case of G.751) or through external overhead interface or from configuration register or internal generation
 - Inserts FA1, FA2, EM, TR, MA and GC bytes into G.832 stream or FAS service bits and BIP4 (if enabled) into G.751 stream
-

- Inserts MA,NR,GC and TR (TTB) from microprocessor accessible registers (service bit for G.751)
- Inserts FEBE in MA upon receipt of EM byte errors.Programmable through register bit (G.832)
- Asserts FERF upon any combination of LOS,OOF or AIS received from receiver (G.832)
- Inserts synchronous status message from microprocessor accessible registers, when enabled (G.832)
- Error masks for framing bytes, and computed parity (BIP-8 in case of G.832 and BIP-4 in case of G.751)
- Optionally accepts overhead bits (except FA bytes for G.832 and FAS bits for G.751) from input interface

E3/DS3/STS-1 DE-JITTERING/DE-SYNC CIRCUIT

- Meets the E3/DS3/STS-1 jitter requirements
- Compliant with jitter transfer template outlined in ITU G.751,G.752,G.755 and GR-499-CORE
- Meets output jitter requirement as specified by ETSI TBR24
- Meets the jitter and wander specifications described in T1.105.03b,GR-253 and GR-499 standards
- Performs the De-synchronizer function and pointer adjustments for STS-1 to DS3 mapping

PERFORMANCE MONITORING

- Supports line and path performance monitoring
- Provides 32-bit saturating counter of OOF errors
- Provides 32-bit saturating counter LOF errors
- Provides 32-bit saturating counter of LOS errors
- Provides 32-bit saturating counter of SD errors
- Provides 32-bit saturating counter of SF errors
- Provides 32-bit saturating counter B3 errors
- Provides 32-bit saturating counter of the line RDI, path AIS,REI-L errors, REI-P errors and BIP-8(B1,B2),B3 errors and loss of pointer
- Provides 16-bit saturating counter of DS3 framing bit errors, DS3 frame parity errors, line code violations, frame parity (BIP) errors, DS3 frame CP bit errors and DS3 Far-End Block errors
- One second statistics
 1. Bipolar violations
 2. Frames with parity errors
 3. Frames with CP bit errors
 4. Errored second indication
 5. Severely errored second indication

INTERRUPT, STATUS AND TEST

- Provides individually maskable interrupts
 - Provides one second interrupt generations
 - Generates interrupts from the following causes:
 - DS3 OOF status change, LOS status change, DS3 AIS status, LAPD message received, DS3 parity error,DS3 FEAC validation, DS3 FEAC removal, DS3 IDLE status change, FEBE (E3) change, DS3 FERF change, DS3 format change (AIC), LAPD end of message transmission and DS3 FEAC end of message transmission, DS3 Framing alignment change, SONET OOF status change and COFA
 - Provides local and remote line loopback
-

XRT94L43

SONET/SDH OC-12 TO 12XDS3/E3 MAPPER

- Provides SONET remote loopback

ORDERING INFORMATION

PART NUMBER	PACKAGE TYPE	OPERATING TEMPERATURE RANGE
XRT94L43IB	516 Ball BGA	-40°C to +85°C

FIGURE 4. PIN OUT OF THE XRT94L43

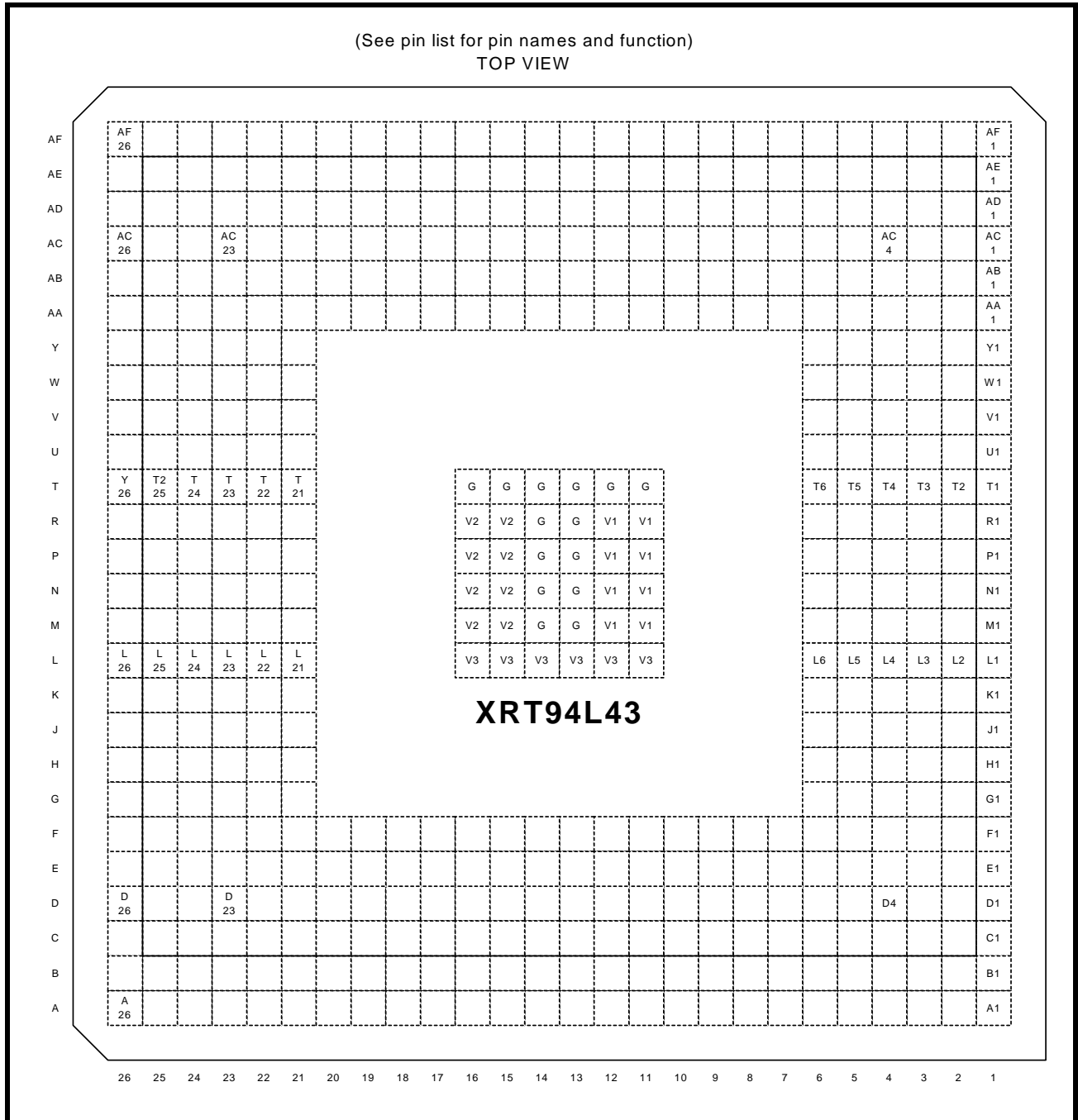

TABLE OF CONTENTS

GENERAL DESCRIPTION	1
FEATURES	1
APPLICATIONS	1
FIGURE 1. BLOCK DIAGRAM OF THE XRT94L43 WHEN CONFIGURED IN SONET MODE	2
FIGURE 2. BLOCK DIAGRAM OF THE XRT94L43 WHEN CONFIGURED IN SDH/TUG-3 MODE	3
FIGURE 3. BLOCK DIAGRAM OF THE XRT94L43 WHEN CONFIGURED IN SDH/AU-3 MODE	3
PRODUCT FEATURES	4
SONET TRANSMITTER	4
SONET RECEIVER	4
MAPPER	5
DS3 RECEIVE FRAMER	5
DS3 TRANSMIT FRAMER	6
E3 RECEIVE FRAMER	6
E3 TRANSMIT FRAMER	7
E3/DS3/STS-1 DE-JITTERING/DE-SYNC CIRCUIT	8
PERFORMANCE MONITORING	8
INTERRUPT, STATUS AND TEST	8
ORDERING INFORMATION	10
FIGURE 4. PIN OUT OF THE XRT94L43	10
TABLE OF CONTENTS	I
PIN DESCRIPTIONS - DIRECT ADDRESSING	8
MICROPROCESSOR INTERFACE	8
SONET/SDH SERIAL LINE INTERFACE PINS	13
STS-12/STM-4 TELECOM BUS INTERFACE - TRANSMIT DIRECTION	19
STS-12/STM-4 TELECOM BUS INTERFACE - RECEIVE DIRECTION	22
SONET/SDH OVERHEAD INTERFACE - TRANSMIT DIRECTION	24
STS-3/STM-1 TELECOM BUS INTERFACE - TRANSMIT DIRECTION	33
RxSTS-1 TOH/POH INTERFACE	82
STS-3/STM-1 TELECOM BUS INTERFACE - RECEIVE DIRECTION	85
RECEIVE TRANSPORT OVERHEAD INTERFACE	128
GENERAL PURPOSE INPUT/OUTPUT	135
CLOCK INPUTS	139
BOUNDARY SCAN	139
MISCELLANEOUS PINS	139
POWER SUPPLY PINS	140
VDD = 3.3V	140
VDD (2.5V)	140
GROUND	142
No CONNECTS	142
PIN DESCRIPTIONS - INDIRECT ADDRESSING	144
MICROPROCESSOR INTERFACE	144
SONET/SDH SERIAL LINE INTERFACE PINS	146
STS-12/STM-4 TELECOM BUS INTERFACE - TRANSMIT DIRECTION	153
STS-12/STM-4 TELECOM BUS INTERFACE - RECEIVE DIRECTION	156
SONET/SDH OVERHEAD INTERFACE - TRANSMIT DIRECTION	158
STS-3/STM-1 TELECOM BUS INTERFACE - TRANSMIT DIRECTION	167
RxSTS-1 TOH/POH INTERFACE	219
STS-3/STM-1 TELECOM BUS INTERFACE - RECEIVE DIRECTION	222
RECEIVE TRANSPORT OVERHEAD INTERFACE	272
GENERAL PURPOSE INPUT/OUTPUT	279
CLOCK INPUTS	287
BOUNDARY SCAN	287
MISCELLANEOUS PINS	287

POWER SUPPLY PINS	288
VDD = 3.3V.....	288
VDD (2.5V)	288
GROUND	290
NO CONNECTS.....	290
DC ELECTRICAL CHARACTERISTICS	292
DC CHARACTERISTICS FOR TTL INPUT/CMOS OUTPUT	292
DC CHARACTERISTICS FOR LVPECL I/O	292
AC ELECTRICAL CHARACTERISTICS.....	293
1.0 MICROPROCESSOR INTERFACE TIMING FOR REVISION D SILICON	293
1.1 MICROPROCESSOR INTERFACE TIMING - ASYNCHRONOUS INTEL MODE	293
FIGURE 5. ASYNCHRONOUS MODE 1 - INTEL TYPE PROGRAMMED I/O TIMING (WRITE CYCLE).....	293
FIGURE 6. ASYNCHRONOUS MODE 1 - INTEL TYPE PROGRAMMED I/O TIMING (READ CYCLE).....	293
TABLE 1: TIMING INFORMATION FOR THE MICROPROCESSOR INTERFACE, WHEN CONFIGURED TO OPERATE IN THE INTEL ASYNCHRONOUS MODE	294
1.2 MICROPROCESSOR INTERFACE TIMING - ASYNCHRONOUS MOTOROLA (68K) MODE	294
FIGURE 7. ASYNCHRONOUS MODE 2 - MOTOROLA 68K PROGRAMMED I/O TIMING (WRITE CYCLE).....	294
FIGURE 8. ASYNCHRONOUS MODE 2 - MOTOROLA 68K PROGRAMMED I/O TIMING (READ CYCLE)	295
TABLE 2: TIMING INFORMATION FOR THE MICROPROCESSOR INTERFACE WHEN CONFIGURED TO OPERATE IN THE MOTOROLA (68K) ASYNCHRONOUS MODE	295
1.3 MICROPROCESSOR INTERFACE TIMING - POWER PC 403 SYNCHRONOUS MODE	296
FIGURE 9. SYNCHRONOUS MODE 3 - IBM POWERPC 403 INTERFACE TIMING (WRITE CYCLE).....	296
FIGURE 10. SYNCHRONOUS MODE 3 - IBM POWERPC 403 INTERFACE TIMING (READ CYCLE).....	297
TABLE 3: TIMING INFORMATION FOR THE MICROPROCESSOR INTERFACE, WHEN CONFIGURED TO OPERATE IN THE IBM POWER PC403 MODE	297
1.4 MICROPROCESSOR INTERFACE TIMING - IDT3051/52 MODE.....	298
FIGURE 11. SYNCHRONOUS MODE 4 - IDT3051/52 INTERFACE TIMING (WRITE CYCLE).....	298
FIGURE 12. SYNCHRONOUS MODE 4 - IDT3051/52 INTERFACE TIMING (READ CYCLE).....	299
TABLE 4: TIMING INFORMATION FOR THE MICROPROCESSOR INTERFACE, WHEN CONFIGURED TO OPERATE IN THE IDT3051/52 MODE	299
2.0 STS-12/STM-4 TELECOM BUS INTERFACE TIMING INFORMATION.....	299
2.1 STS-12/STM-4 TELECOM BUS INTERFACE TIMING INFORMATION.....	300
2.2 THE TRANSMIT STS-12/STM-4 TELECOM BUS INTERFACE TIMING	300
FIGURE 13. WAVEFORMS OF THE SIGNALS THAT ARE OUTPUT VIA THE TRANSMIT STS-12/STM-4 TELECOM BUS INTERFACE	300
FIGURE 14. TIMING RELATIONSHIPS BETWEEN THE TXSBFP INPUT PIN AND THE TXA_CLK OUTPUT PIN WITHIN THE TRANSMIT STS-12/STM-4 TELECOM BUS INTERFACE	301
TABLE 5: TIMING INFORMATION FOR THE TRANSMIT STS-12/STM-4 TELECOM BUS INTERFACE	301
2.3 THE RECEIVE STS-12/STM-4 TELECOM BUS INTERFACE TIMING	301
FIGURE 15. WAVEFORMS OF THE SIGNALS THAT ARE INPUT VIA THE RECEIVE STS-12/STM-4 TELECOM BUS INTERFACE	302
TABLE 6: TIMING INFORMATION FOR THE RECEIVE STS-12/STM-4 TELECOM BUS INTERFACE	302
3.0 STS-12/STM-4 PECL INTERFACE TIMING INFORMATION	303
3.1 THE RECEIVE STS-12/STM-4 PECL INTERFACE TIMING.....	303
FIGURE 16. WAVEFORMS OF THE SIGNALS THAT ARE INPUT VIA THE RECEIVE STS-12/STM-4 PECL INTERFACE.....	303
TABLE 7: TIMING INFORMATION FOR THE RECEIVE STS-12/STM-4 PECL INTERFACE	303
3.2 THE TRANSMIT STS-12/STM-4 PECL INTERFACE BLOCK.....	304
FIGURE 17. WAVEFORMS OF THE TRANSMIT STS-12/STM-4 PECL INTERFACE SIGNALS	304
TABLE 8: TIMING INFORMATION FOR THE TRANSMIT STS-12/STM-4 PECL INTERFACE	304
4.0 DS3/E3/STS-1 LIU INTERFACE TIMING INFORMATION.....	304
4.1 INGRESS DS3/E3/STS-1 INTERFACE TIMING.....	304
FIGURE 18. WAVEFORMS OF THE DS3/E3/STS-1 SIGNALS THAT ARE INPUT TO THE DS3/E3/STS-1 LIU INTERFACE IN THE INGRESS DIRECTION	305
4.2 INGRESS TIMING FOR DS3/E3 APPLICATIONS.....	305
TABLE 9: TIMING INFORMATION FOR THE INGRESS DS3/E3/STS-1 LIU INTERFACE FOR DS3/E3 APPLICATIONS WHEN THE DS3/E3 FRAMER BLOCK HAS BEEN CONFIGURED TO SAMPLE THE DS3/E3/STS_1_DATA_IN AND DS3/E3/STS_1_NEG_IN INPUT PINS UPON THE RISING EDGE OF DS3/E3/STS_1_CLOCK_IN	305
TABLE 10: TIMING INFORMATION FOR THE INGRESS DS3/E3/STS-1 LIU INTERFACE FOR DS3/E3 APPLICATIONS AND WHEN THE DS3/E3 FRAMER BLOCK HAS BEEN CONFIGURED TO SAMPLE THE DS3/E3/STS_1_DATA_IN AND DS3/E3/STS_1_NEG_IN INPUT PINS UPON THE FALLING EDGE OF DS3/E3/STS_1_CLOCK_IN	306
4.3 INGRESS TIMING FOR STS-1/STM-0 APPLICATIONS	306
TABLE 11: TIMING INFORMATION FOR THE INGRESS DS3/E3/STS-1 LIU INTERFACE FOR STS-1/STM-0 APPLICATIONS	306
4.4 THE EGRESS DS3/E3/STS-1 INTERFACE TIMING.....	306
FIGURE 19. WAVEFORMS OF THE DS3/E3/STS-1 SIGNALS THAT ARE OUTPUT FROM THE DS3/E3/STS-1 LIU INTERFACE (IN THE RECEIVE/EGRESS DIRECTION).....	307

4.5 EGRESS TIMING FOR DS3/E3 APPLICATIONS 307
 TABLE 12: TIMING INFORMATION FOR THE EGRESS DS3/E3/STS-1 LIU INTERFACE FOR DS3/E3 APPLICATIONS AND WHEN THE DS3/E3 FRAMER BLOCK HAS BEEN CONFIGURED TO OUTPUT THE OUTBOUND DS3/E3 DATA (VIA THE DS3/E3/STS_1_DATA_OUT AND DS3/E3/STS_1_NEG_OUT OUTPUT PINS) UPON THE RISING EDGE OF DS3/E3/STS_1_CLOCK_OUT 307
 TABLE 13: TIMING INFORMATION FOR THE EGRESS DS3/E3/STS-1 LIU INTERFACE FOR DS3/E3 APPLICATIONS AND WHEN THE DS3/E3 FRAMER BLOCK HAS BEEN CONFIGURED TO OUTPUT THE OUTBOUND DS3/E3 DATA (VIA THE DS3/E3/STS_1_DATA_OUT AND DS3/E3/STS_1_NEG_OUT OUTPUT PINS) UPON THE FALLING EDGE OF DS3/E3/STS_1_CLOCK_OUT 307

4.6 EGRESS TIMING FOR STS-1/STM-0 APPLICATIONS..... 308
 TABLE 14: TIMING INFORMATION FOR THE EGRESS DS3/E3/STS-1 LIU INTERFACE FOR STS-1/STM-0 APPLICATIONS 308

5.0 STS-3/STM-1 TELECOM BUS INTERFACE TIMING INFORMATION 308

5.1 STS-3/STM-1 TELECOM BUS INTERFACE TIMING INFORMATION 308

5.2 THE RECEIVE STS-3/STM-1 TELECOM BUS INTERFACE TIMING 308
 FIGURE 20. WAVEFORMS OF THE SIGNALS THAT ARE OUTPUT VIA THE RECEIVE STS-3/STM-1 TELECOM BUS INTERFACE 309
 TABLE 15: TIMING INFORMATION FOR THE RECEIVE STS-3/STM-1 TELECOM BUS INTERFACE 309

5.3 THE TRANSMIT STS-3/STM-1 TELECOM BUS INTERFACE TIMING..... 309
 FIGURE 21. WAVEFORMS OF THE SIGNALS THAT ARE INPUT VIA THE TRANSMIT STS-3/STM-1 TELECOM BUS INTERFACE 310
 TABLE 16: TIMING INFORMATION FOR THE TRANSMIT STS-3/STM-1 TELECOM BUS INTERFACE 310

6.0 TRANSMIT TOH OVERHEAD INPUT PORT 310

6.1 TRANSMIT TOH OVERHEAD INPUT PORT 310
 FIGURE 22. TIMING WAVEFORM OF THE TRANSMIT TOH OVERHEAD INPUT PORT 311
 TABLE 17: TIMING INFORMATION FOR THE TRANSMIT TOH OVERHEAD INPUT PORT 311

7.0 TRANSMIT POH OVERHEAD INPUT PORT..... 311

7.1 TRANSMIT POH OVERHEAD INPUT PORT 311
 FIGURE 23. TIMING WAVEFORM OF THE TRANSMIT POH OVERHEAD INPUT PORT 312
 TABLE 18: TIMING INFORMATION FOR THE TRANSMIT POH OVERHEAD INPUT PORT 312

8.0 TRANSMIT ORDERWIRE (E1, F1, E2) BYTE OVERHEAD INPUT PORT 312

8.1 TRANSMIT E1, F1, E2 (ORDER-WIRE) BYTE OVERHEAD INPUT PORT 312
 FIGURE 24. TIMING WAVEFORM OF THE TRANSMIT ORDER-WIRE BYTE OVERHEAD INPUT PORT 313
 TABLE 19: TIMING INFORMATION FOR THE TRANSMIT ORDER-WIRE BYTE OVERHEAD INPUT PORT 313

9.0 TRANSMIT SECTION DCC INSERTION INPUT PORT 313

9.1 TRANSMIT SECTION DCC INSERTION INPUT PORT..... 313
 FIGURE 25. TIMING WAVEFORM OF THE TRANSMIT SECTION DCC OVERHEAD INSERTION PORT 314
 TABLE 20: TIMING INFORMATION FOR THE TRANSMIT ORDER-WIRE BYTE OVERHEAD INPUT PORT 314

10.0 TRANSMIT LINE DCC INSERTION INPUT PORT 314

10.1 TRANSMIT LINE DCC INSERTION INPUT PORT..... 314
 FIGURE 26. TIMING WAVEFORM OF THE TRANSMIT LINE DCC INSERTION INPUT PORT 315
 TABLE 21: TIMING INFORMATION FOR THE TRANSMIT LINE DCC INSERTION INPUT PORT 315

11.0 RECEIVE TOH OVERHEAD OUTPUT PORT 315

11.1 RECEIVE TOH OVERHEAD OUTPUT PORT 315
 FIGURE 27. TIMING WAVEFORM OF THE RECEIVE TOH OVERHEAD OUTPUT PORT 316
 TABLE 22: TIMING INFORMATION FOR THE RECEIVE TOH OVERHEAD OUTPUT PORT 316

12.0 RECEIVE POH OVERHEAD OUTPUT PORT 316

12.1 RECEIVE POH OVERHEAD OUTPUT PORT 316
 FIGURE 28. TIMING WAVEFORM OF THE RECEIVE POH OVERHEAD OUTPUT PORT 317
 TABLE 23: TIMING INFORMATION FOR THE RECEIVE POH OVERHEAD OUTPUT PORT 317

13.0 RECEIVE ORDERWIRE (E1, F1, E2) BYTES OVERHEAD OUTPUT PORT 317

13.1 RECEIVE E1, F1, E2 (ORDER-WIRE) BYTE OVERHEAD OUTPUT PORT 317
 FIGURE 29. TIMING WAVEFORM OF THE RECEIVE ORDER-WIRE BYTE OVERHEAD OUTPUT PORT 318
 TABLE 24: TIMING INFORMATION FOR THE RECEIVE ORDER-WIRE BYTE OVERHEAD OUTPUT PORT 318

14.0 RECEIVE SECTION DCC EXTRACTION OUTPUT PORT 318

14.1 RECEIVE SECTION DCC OUTPUT PORT 318
 FIGURE 30. TIMING WAVEFORM OF THE RECEIVE SECTION DCC OUTPUT PORT 319
 TABLE 25: TIMING INFORMATION FOR THE RECEIVE SECTION DCC OUTPUT PORT 319

15.0 RECEIVE LINE DCC EXTRACTION OUTPUT PORT 319

15.1 RECEIVE LINE DCC OUTPUT PORT 319
 FIGURE 31. TIMING WAVEFORM OF THE RECEIVE LINE DCC OUTPUT PORT 320
 TABLE 26: TIMING INFORMATION FOR THE RECEIVE LINE DCC OUTPUT PORT 320

ORDERING INFORMATION..... 321

PACKAGE DIMENSIONS..... 321

REVISION HISTORY..... 322

PIN DESCRIPTIONS - DIRECT ADDRESSING

MICROPROCESSOR INTERFACE

PIN #	SIGNAL NAME	I/O	SIGNAL TYPE	DESCRIPTION												
U22	PCLK	I	TTL	<p>Microprocessor Interface Clock Input:</p> <p>This clock input signal is only used if the Microprocessor Interface has been configured to operate in one of the Synchronous Modes (e.g., Power PC 403 Mode). If the Microprocessor Interface is configured to operate in one of these modes, then it will use this clock signal to do the following.</p> <ul style="list-style-type: none"> • To sample the \overline{CS}, $\overline{WR/R/\overline{W}}$, A[15:0], D[7:0], $\overline{RD/DS}$ and DBEN input pins, and • To update the state of the D[7:0] and the RDY/DTACK output signals. <p>NOTES:</p> <ol style="list-style-type: none"> 1. The Microprocessor Interface can work with μPCLK frequencies ranging up to 66MHz. 2. This pin is inactive if the user has configured the Microprocessor Interface to operate in either the Intel-Asynchronous or the Motorola-Asynchronous Modes. In this case, the user should tie this pin to GND. 												
L25 L23 L22	PTYPE_0 PTYPE_1 PTYPE_2	I	TTL	<p>Microprocessor Type Select input:</p> <p>These three input pins are used to configure the Microprocessor Interface block to readily support a wide variety of Microprocessor Interfaces. The relationship between the settings of these input pins and the corresponding Microprocessor Interface configuration is presented below.</p> <p>PTYPE[2:0] Microprocessor Interface Mode</p> <table> <tr> <td>000</td> <td>Intel - Asynchronous Mode</td> </tr> <tr> <td>1001</td> <td>Motorola - Asynchronous Mode (Motorola 68k)</td> </tr> <tr> <td>010</td> <td>Intel X86</td> </tr> <tr> <td>011</td> <td>Intel I960</td> </tr> <tr> <td>100</td> <td>IDT3051/52 (MIPS)</td> </tr> <tr> <td>101</td> <td>Power PC 403 Mode</td> </tr> </table>	000	Intel - Asynchronous Mode	1001	Motorola - Asynchronous Mode (Motorola 68k)	010	Intel X86	011	Intel I960	100	IDT3051/52 (MIPS)	101	Power PC 403 Mode
000	Intel - Asynchronous Mode															
1001	Motorola - Asynchronous Mode (Motorola 68k)															
010	Intel X86															
011	Intel I960															
100	IDT3051/52 (MIPS)															
101	Power PC 403 Mode															
A23 F24 W21 AE22 A25 H24 AB23 AD15 V26 R24 P26 M24 T26 M22 M25 L26	PADDR_0 PADDR_1 PADDR_2 PADDR_3 PADDR_4 PADDR_5 PADDR_6 PADDR_7 PADDR_8 PADDR_9 PADDR_10 PADDR_11 PADDR_12 PADDR_13 PADDR_14 PADDR_15	I	TTL	<p>Address Bus Input pins (Microprocessor Interface):</p> <p>These pins permit the Microprocessor to identify on-chip registers and Buffer/Memory locations (within the XRT94L43) whenever it performs READ and WRITE operations with the XRT94L43.</p>												

MICROPROCESSOR INTERFACE

PIN #	SIGNAL NAME	I/O	SIGNAL TYPE	DESCRIPTION
T22 R22 U24 R21 W26 T25 R25 R26	PDATA_0 PDATA_1 PDATA_2 PDATA_3 PDATA_4 PDATA_5 PDATA_6 PDATA_7	I/O	TTL	<p>Bi-Directional Data Bus Pins (Microprocessor Interface):</p> <p>These pins are used to drive and receive data over the bi-directional data bus, whenever the Microprocessor performs READ or WRITE operations with the Microprocessor Interface of the XRT94L43.</p>
Y26	\overline{WR} / R/\overline{W}	I	TTL	<p>Write Strobe/Read-Write operation Identifier:</p> <p>The function of this input pin depends upon which mode the Microprocessor Interface has been configured to operate in.</p> <p>Intel-Asynchronous Mode - \overline{WR} - Write Strobe Input:</p> <p>If the Microprocessor Interface is configured to operate in the Intel-Asynchronous Mode, then this input pin functions as the \overline{WR} (Active Low WRITE Strobe) input signal from the Microprocessor. Once this active-low signal is asserted, then the input buffers (associated with the Bi-Directional Data Bus pin, D[7:0]) will be enabled. The Microprocessor Interface will latch the contents on the Bi-Directional Data Bus (into the "target" register or address location, within the XRT94L43) upon the rising edge of this input pin.</p> <p>Motorola-Asynchronous Mode - R/\overline{W} - Read/Write Operation Identification Input Pin:</p> <p>If the Microprocessor Interface is operating in the "Motorola-Asynchronous Mode", then this pin is functionally equivalent to the "R/\overline{W}" input pin. In the Motorola Mode, a "READ" operation occurs if this pin is held at a logic "1", coincident to a falling edge of the RD/DS (Data Strobe) input pin. Similarly a WRITE operation occurs if this pin is at a logic "0", coincident to a falling edge of the RD/DS (Data Strobe) input pin.</p> <p>Power PC 403 Mode - R/\overline{W} - Read/Write Operation Identification Input:</p> <p>If the Microprocessor Interface is configured to operate in the Power PC 403 Mode, then this input pin will function as the "Read/Write Operation Identification Input" pin.</p> <p>Anytime the Microprocessor Interface samples this input signal at a logic low (while also sampling the \overline{CS} input pin "low") upon the rising edge of μPCLK, then the Microprocessor Interface will (upon the very same rising edge of μPCLK) latch the contents of the Address Bus (A[15:0]) into the Microprocessor Interface circuitry, in preparation for this forthcoming READ operation. At some point (later in this READ operation) the Microprocessor will also assert the DBEN/OE input pin, and the Microprocessor Interface will then place the contents of the "target" register (or address location within the XRT94L43) upon the Bi-Directional Data Bus pins (D[7:0]), where it can be read by the Microprocessor .</p> <p>Anytime the Microprocessor Interface samples this input signal at a logic high (while also sampling the \overline{CS} input pin a logic "low") upon the rising edge of μPCLK, then the Microprocessor Interface will (upon the very same rising edge of μPCLK) latch the contents of the Address Bus (A[15:0]) into the Microprocessor Interface circuitry, in preparation for the forthcoming WRITE operation. At some point (later in this WRITE operation) the Microprocessor will also assert the $\overline{RD/DS/\overline{WE}}$ input pin, and the Microprocessor Interface will then latch the contents of the Bi-Directional Data Bus (D[7:0]) into the contents of the "target" register or buffer location (within the XRT94L43).</p>

MICROPROCESSOR INTERFACE

PIN #	SIGNAL NAME	I/O	SIGNAL TYPE	DESCRIPTION
T23	$\overline{RD}/$ $\overline{DS}/$ \overline{WE}	I	TTL	<p>READ Strob/Data Strobe: The function of this input pin depends upon which mode the Microprocessor Interface has been configured to operate in.</p> <p>Intel-Asynchronous Mode - \overline{RD} - READ Strobe Input: If the Microprocessor Interface is operating in the Intel-Asynchronous Mode, then this input pin will function as the \overline{RD} (Active Low Read Strobe) input signal from the Microprocessor. Once this active-low signal is asserted, then the XRT94L43 will place the contents of the addressed register (or buffer location) on the Microprocessor Interface Bi-directional data bus (D[7:0]). When this signal is negated, then the Data Bus will be tri-stated.</p> <p>Motorola-Asynchronous (68K) Mode - \overline{DS} - Data Strobe: If the Microprocessor Interface is operating in the Motorola-Asynchronous Mode, then this input pin will function as the \overline{DS} (Data Strobe) input signal.</p> <p>Power PC 403 Mode - \overline{WE} - Write Enable Input: If the Microprocessor Interface is operating in the Power PC 403 Mode, then this input pin will function as the \overline{WE} (Write Enable) input pin. Anytime the Microprocessor Interface samples this active-low input signal (along with \overline{CS} and $\overline{WR/R/W}$) also being asserted (at a logic low level) upon the rising edge of μPCLK, then the Microprocessor Interface will (upon the very same rising edge of μPCLK) latch the contents on the Bi-Directional Data Bus (D[7:0]) into the "target" on-chip register or buffer location within the XRT94L43.</p>
R23	PALE/PAS_L	I	TTL	<p>Address Latch Enable/Address Strobe: This input pin is used to latch the address (present at the Microprocessor Interface Address Bus pins (A[6:0]) into the Mapper/Framer Microprocessor Interface block and to indicate the start of a READ or WRITE cycle. This input pin is active-High, in the Intel Mode and active-Low in the Motorola Mode.</p>
V22	PCS_L	I	TTL	<p>Chip Select Input: The user must assert this active low signal in order to select the Microprocessor Interface for READ and WRITE operations between the Microprocessor and the XRT94L43 on-chip registers and buffer locations.</p>

MICROPROCESSOR INTERFACE

PIN #	SIGNAL NAME	I/O	SIGNAL TYPE	DESCRIPTION
Y25	PRDY_L/ DTACK/ RDY	O	CMOS	<p>READY or DTACK Output:</p> <p>The function of this input pin depends upon which mode the Microprocessor Interface has been configured to operate in.</p> <p>Intel-Asynchronous Mode - $\overline{\text{RDY}}$ - Ready Output:</p> <p>If the Microprocessor Interface has been configured to operate in the Intel-Asynchronous Mode, then this output pin will function as the "active-low" READY output.</p> <p>During a READ or WRITE cycle, the Microprocessor Interface block will toggle this output pin to the logic low level, ONLY when it (the Microprocessor Interface) is ready to complete or terminate the current READ or WRITE cycle. Once the Microprocessor has determined that this input pin has toggled to the logic "low" level, then it is now safe for it to move on and execute the next READ or WRITE cycle.</p> <p>If (during a READ or WRITE cycle) the Microprocessor Interface block is holding this output pin at a logic "high" level, then the Microprocessor is expected to extend this READ or WRITE cycle, until it detects this output pin being toggled to the logic low level.</p> <p>Motorola-Asynchronous Mode - $\overline{\text{DTACK}}$ - Data Transfer Acknowledge Output</p> <p>If the Microprocessor Interface has been configured to operate in the Motorola-Asynchronous Mode, then this output pin will function as the "active-low" DTACK output.</p> <p>During a READ or WRITE cycle, the Microprocessor Interface block will toggle this output pin to the logic low level, ONLY when it (the Microprocessor Interface) is ready to complete or terminate the current READ or WRITE cycle. Once the Microprocessor has determined that this input pin has toggled to the logic "low" level, then it is now safe for it to move on and execute the next READ or WRITE cycle.</p> <p>If (during a READ or WRITE cycle) the Microprocessor Interface block is holding this output pin at a logic "high" level, then the Microprocessor is expected to extend this READ or WRITE cycle, until it detects this output pin being toggled to the logic low level.</p> <p>Power PC 403 Mode - RDY - Ready Output:</p> <p>If the Microprocessor Interface has been configured to operate in the Power PC 403 Mode, then this output pin will function as the "active-high" READY output. During a READ or WRITE cycle, the Microprocessor Interface block will toggle this output pin to the logic high level, ONLY when it (the Microprocessor Interface) is ready to complete or terminate the current READ or WRITE cycle. Once the Microprocessor has sampled this signal being at the logic "high" level (upon the rising edge of PCLK), then it is now safe for it to move on and execute the next READ or WRITE cycle.</p> <p>If (during a READ or WRITE cycle) the Microprocessor Interface block is holding this output pin at a logic "low" level, then the Microprocessor is expected to extend this READ or WRITE cycle, until it samples this output pin being at the logic low level.</p> <p>NOTE: The Microprocessor Interface will update the state of this output pin upon the rising edge of μPCLK.</p>

MICROPROCESSOR INTERFACE

PIN #	SIGNAL NAME	I/O	SIGNAL TYPE	DESCRIPTION
T21	PDBEN_L	I	TTL	<p>Bi-directional Data Bus Enable Input Pin:</p> <p>This input pin permits the user to either enable or tri-state the Bi-Directional Data Bus pins (D[7:0]), as described below.</p> <p>Setting this input pin "low" enables the Bi-directional Data bus. Setting this input "high" tri-states the Bi-directional Data Bus.</p>
U25	PBLAST_L	I	TTL	<p>Last Burst Transfer Indicator input Pin:</p> <p>If the Microprocessor Interface is operating in the Intel-I960 Mode, then this input pin is used to indicate (to the Microprocessor Interface block) that the current data transfer is the last data transfer within the current burst operation.</p> <p>The Microprocessor should assert this input pin (by toggling it "Low") in order to denote that the current READ or WRITE operation (within a BURST operation) is the last operation of this BURST operation.</p> <p>NOTE: <i>If the user has configured the Microprocessor Interface to operate in the Intel-Asynchronous, the Motorola-Asynchronous or the Power PC 403 Mode, then he/she should tie this input pin to GND.</i></p>
AC26	PINT_L	O	CMOS	<p>Interrupt Request Output:</p> <p>This active-Low, active-low output signal will be asserted when the XRT94L43 is requesting interrupt service from the Microprocessor. This output pin should typically be connected to the Interrupt Request input of the Microprocessor.</p>
L24	RESET_L	I	TTL	<p>Reset Input:</p> <p>When this active-Low signal is asserted, the XRT94L43 will be asynchronously reset. When this occurs, all outputs will be tri-stated and all on-chip registers will be reset to their default values.</p>
M26	FULL_ADDR_SEL	I	TTL	<p>Full Address Select input pin: This input pin, along with "DIRECT_ADD_SEL" (pin M23) must both be pulled "HIGH" in order to configure the Microprocessor Interface block to operate in the "Full Address" Mode. If the Microprocessor Interface is configured to operate in the "Full Address" Mode, then it will then provide a 16-bit Address Bus (which is sufficient to "Directly Address" all of the on-chip registers.</p>
M23	DIRECT_ADD_SEL	I	TTL	<p>Direct Address Select input pin: This input pin, along with "FULL_ADDR_SEL" (pin M26) must both be pulled "HIGH" in order to configure the Microprocessor Interface block to operate in the "Full Address" Mode. If the Microprocessor Interface is configured to operate in the "Full Address" Mode, then it will then provide a 16-bit Address Bus (which is sufficient to "Directly Address" all of the on-chip registers.</p>

SONET/SDH SERIAL LINE INTERFACE PINS

PIN #	SIGNAL NAME	I/O	SIGNAL TYPE	DESCRIPTION
M5	RXL_CLKL_P	I	LVPECL	<p>Receive STS-12/STM-4 Clock - Positive Polarity PECL Input:</p> <p>This input pin, along with RXL_CLKL_N functions as the Recovered Clock Input, from a System back-plane or an Optical Transceiver. The Receive STS-12/STM-4 Interface Block will sample the data, applied at the RXLDATA_P/RXLDATA_N input pins, upon the rising edge of this signal.</p> <p>NOTE: For APS (Automatic Protection Switching) purposes, this input pin, along with RXL_CLKL_N functions as the Primary Receive Clock Input port.</p>
L5	RXL_CLKL_N	I	LVPECL	<p>Receive STS-12/STM-4 Clock - Negative Polarity PECL Input:</p> <p>This input pin, along with RXL_CLKL_P functions as the Recovered Clock Input, from a System back-plane or an Optical Transceiver. The Receiver STS-12/STM-4 Interface Block will sample the data applied at the RXLDATA_P/RXLDATA_N input pins, upon the falling edge of this signal.</p> <p>NOTE: For APS (Automatic Protection Switching) purposes, this input pin, along with RXL_CLKL_P functions as the Primary Receive Clock Input Port.</p>
K2	RXL_CLKL_R_P	I	LVPECL	<p>Receive STS-12/STM-4 Clock - Positive Polarity PECL Input - Redundant Port:</p> <p>This input pin, along with RXL_CLKL_R_N functions as the Recovered Clock Input, from a System back-plane or an Optical Transceiver. The Receive STS-12/STM-4 Interface Block will sample the data, applied at the RXLDATA_P/RXLDATA_N input pins, upon the rising edge of this signal.</p> <p>NOTE: For APS (Automatic Protection Switching) purposes, this input pin, along with RXL_CLKL_R_N functions as the Redundant Receive Clock Input Port.</p>
K1	RXL_CLKL_R_N	I	LVPECL	<p>Receive STS-12/STM-4 Clock - Negative Polarity PECL Input - Redundant Port:</p> <p>This input pin, along with RXL_CLKL_P functions as the Recovered Clock Input, from a System back-plane or an Optical Transceiver. The Receiver STS-12/STM-4 Interface Block will sample the data applied at the RXLDATA_P/RXLDATA_N input pins, upon the falling edge of this signal.</p> <p>NOTE: For APS (Automatic Protection Switching) purposes, this input pin, along with RXL_CLKL_R_P functions as the Redundant Receive Clock Input Port.</p>
K4	RXL_DATA_P	I	LVPECL	<p>Receive STS-12/STM-4 Data - Positive Polarity PECL Input:</p> <p>This input pin, along with RXL_DATA_N functions as the Recovered Data Input, from a System back-plane or an Optical Transceiver. The Receive STS-12/STM-4 Interface block will sample the data applied to these input pins, upon the rising edge of the RXL_CLKL_P (and the falling edge of the RXL_CLKL_N) signals.</p> <p>NOTE: For APS (Automatic Protection Switching) purposes, this input pin, along with RXL_DATA_N functions as the Primary Receive Data Input Port.</p>

SONET/SDH SERIAL LINE INTERFACE PINS

PIN #	SIGNAL NAME	I/O	SIGNAL TYPE	DESCRIPTION
L4	RXL_DATA_N	I	LVPECL	<p>Receive STS-12/STM-4 Data - Negative Polarity PECL Input:</p> <p>This input pin, along with RXL_DATA_P functions as the Recovered Data Input, from a System back-plane or an Optical Transceiver. The Receive STS-12/STM-4 Interface block will sample the data applied to these input pins, upon the rising edge of the RXL_CLKL_P (and the falling edge of the RXL_CLKL_N) signals.</p> <p>NOTE: For APS (Automatic Protection Switching) purposes, this input pin, along with RXL_DATA_P functions as the Primary Receive Data Input Port.</p>
K3	RXL_DATA_R_P	I	LVPECL	<p>Receive STS-12/STM-4 Data - Positive Polarity PECL Input - Redundant Port:</p> <p>This input pin, along with RXL_DATA_R_N functions as the Recovered Data Input, from a System back-plane or an Optical Transceiver. The Receive STS-12/STM-4 Interface block will sample the data applied to these input pins, upon the rising edge of the RXL_CLKL_R_P (and the falling edge of the RXL_CLKL_R_N) signals.</p> <p>NOTE: For APS (Automatic Protection Switching) purposes, this input pin, along with RXL_DATA_R_N functions as the Redundant Receive Data Input Port.</p>
L3	RXL_DATA_R_N	I	LVPECL	<p>Receive STS-12/STM-4 Data - Negative Polarity PECL Input - Redundant Port:</p> <p>This input pin, along with RXL_DATA_R_P functions as the Recovered Data Input, from a System back-plane or an Optical Transceiver. The Receive STS-12/STM-4 Interface block will sample the data applied to these input pins, upon the rising edge of the RXL_CLKL_R_P (and the falling edge of the RXL_CLKL_R_N) signals.</p> <p>NOTE: For APS (Automatic Protection Switching) purposes, this input pin, along with RXL_DATA_R_N functions as the Redundant Receive Data Input Port.</p>
T3	TXL_CLKI_P	I	LVPECL	<p>Transmit Reference Clock - Positive Polarity PECL Input:</p> <p>This input pin, along with TxL_CLKI_N can be configured to function as the timing source for the STS-12/STM-4 Transmit Interface Block.</p> <p>If these two input pins are configured to function as the timing source, then a 622.08MHz clock signal must be applied to these input pins in the form of a PECL signal. These two inputs can be configured to function as the timing source by writing the appropriate data into the Interface Control Register - Byte 2 (Indirect Address = 0x00, 0x31), (Direct Address = 0x0131).</p>

SONET/SDH SERIAL LINE INTERFACE PINS

PIN #	SIGNAL NAME	I/O	SIGNAL TYPE	DESCRIPTION
T4	TXL_CLKI_N	I	LVPECL	<p>Transmit Reference Clock - Negative Polarity PECL Input:</p> <p>This input pin, along with TxL_CLKI_P can be configured to function as the timing source for the STS-12/STM-4 Transmit Interface Block.</p> <p>If these two input pins are configured to function as the timing source, then a 622.08MHz clock signal must be applied to these input pins in the form of a PECL signal. These two inputs can be configured to function as the timing source by writing the appropriate data into the Interface Control Register - Byte 2 (Indirect Address = 0x00, 0x31), (Direct Address = 0x0131).</p>
N1	TXL_DATA_P	O	LVPECL	<p>Transmit STS-12/STM-4 Data - Positive Polarity PECL Output:</p> <p>This output pin, along with TXL_DATA_N functions as the Transmit Data Output, to the System back-plane (for transmission to some other System Board) or an Optical Transceiver (for transmission to remote terminal equipment).</p> <p>For High-Speed Back-Plane Applications, it should noted that data is output from these output pins upon the rising/falling edge of TXL_CLKO_P/TXL_CLKO_N).</p> <p>NOTE: For APS (Automatic Protection Switching) purposes, this output pin, along with TXL_DATA_N functions as the Primary Transmit Data Output Port.</p>
N2	TXL_DATA_N	O	LVPECL	<p>Transmit STS-12/STM-4 Data - Negative Polarity PECL Output:</p> <p>This output pin, along with TXL_DATA_P functions as the Transmit Data Output, to the System back-plane (for transmission to some other System Board) or an Optical Transceiver (for transmission to remote terminal equipment).</p> <p>For High-Speed Back-Plane Applications, it should noted that data is output from these output pins upon the rising/falling edge of TXL_CLKO_P/TXL_CLKO_N).</p> <p>NOTE: For APS (Automatic Protection Switching) purposes, this output pin, along with TXL_DATA_P functions as the Primary Transmit Data Output Port.</p>
P1	TXL_DATA_R_P	O	LVPECL	<p>Transmit STS-12/STM-4 Data - Positive Polarity PECL Output - Redundant Port:</p> <p>This output pin, along with TXL_DATA_R_N functions as the Transmit Data Output, to the System back-plane (for transmission to some other System Board) or an Optical Transceiver (for transmission to remote terminal equipment).</p> <p>For High-Speed Back-Plane Applications, it should noted that data is output from these output pins upon the rising/falling edge of TXL_CLKO_R_P/TXL_CLKO_R_N).</p> <p>NOTE: For APS (Automatic Protection Switching) purposes, this output pin, along with TXL_DATA_N functions as the Redundant Transmit Data Output Port.</p>

SONET/SDH SERIAL LINE INTERFACE PINS

PIN #	SIGNAL NAME	I/O	SIGNAL TYPE	DESCRIPTION
P2	TXL_DATA_R_N	O	LVPECL	<p>Transmit STS-12/STM-4 Data - Negative Polarity PECL Output - Redundant Port:</p> <p>This output pin, along with TXL_DATA_R_P functions as the Transmit Data Output, to the System back-plane (for transmission to some other System Board) or an Optical Transceiver (for transmission to remote terminal equipment).</p> <p>For High-Speed Back-Plane Applications, it should noted that data is output from these output pins upon the rising/falling edge of TXL_CLKO_R_P/TXL_CLKO_R_N).</p> <p>NOTE: For APS (Automatic Protection Switching) purposes, this output pin, along with TXL_DATA_R_P functions as the Redundant Transmit Data Output Port.</p>
M1	TXL_CLKO_P	O	LVPECL	<p>Transmit STS-12/STM-4 Clock - Positive Polarity PECL Output:</p> <p>This output pin, along with TXL_CLKO_N functions as the Transmit Clock Output signal. These output pins are typically used in High-Speed Back-Plane Applications. In this case, outbound STS-12/STM-4 data is output via the TXL_DATA_P/TXL_DATA_N output pins upon the rising edge of this clock signal.</p> <p>NOTE: For APS (Automatic Protection Switching) purposes, this output pin, along with TXL_CLKO_N functions as the Primary Transmit Output Clock signal.</p>
M2	TXL_CLKO_N	O	LVPECL	<p>Transmit STS-12/STM-4 Clock - Negative Polarity PECL Output:</p> <p>This output pin, along with TXLCLKO_P functions as the Transmit Clock Output signal. These output pins are typically used in High-Speed Back-Plane Applications. In this case, outbound STS-12/STM-4 data is output via the TXL_DATA_P/TXL_DATA_N output pins upon the falling edge of this clock signal.</p> <p>NOTE: For APS (Automatic Protection Switching) purposes, this output pin, along with TXL_CLKO_N functions as the Primary Transmit Output Clock signal.</p>
R1	TXL_CLKO_R_P	O	LVPECL	<p>Transmit STS-12/STM-4 Clock - Positive Polarity PECL Output - Redundant Port:</p> <p>This output pin, along with TXL_CLKO_R_N functions as the Transmit Clock Output signal. These output pins are typically used in High-Speed Back-Plane Applications. In this case, outbound STS-12/STM-4 data is output via the TXL_DATA_R_P/TXL_DATA_R_N output pins upon the rising edge of this clock signal.</p> <p>NOTE: For APS (Automatic Protection Switching) purposes, this output pin, along with TXL_CLKO_R_N functions as the Redundant Transmit Output Clock signal.</p>

SONET/SDH SERIAL LINE INTERFACE PINS

PIN #	SIGNAL NAME	I/O	SIGNAL TYPE	DESCRIPTION
R2	TXL_CLKO_R_N	O	LVPECL	<p>Transmit STS-12/STM-4 Clock - Negative Polarity PECL Output - Redundant Port:</p> <p>This output pin, along with TXL_CLKO_R_P functions as the Transmit Clock Output signal. These output pins are typically used in High-Speed Back-Plane Applications. In this case, outbound STS-12/STM-4 data is output via the TXL_DATA_R_P/ TXL_DATA_R_N output pins upon the rising edge of this clock signal.</p> <p>For APS (Automatic Protection Switching) purposes, this output pin, along with TXL_CLKO_R_P functions as the Redundant Transmit Output Clock signal.</p>
R4	REFCLK	I	TTL	<p>77.76MHz or 622.08MHz Clock Synthesizer Reference Clock Input Pin:</p> <p>The function of this input pin depends upon whether or not the Transmit STS-12/STM-4 Clock Synthesizer block is enabled.</p> <p>If Clock Synthesizer is Enabled.</p> <p>If the Transmit STS-12/STSM-4 Clock Synthesizer block is to be used to generate the 77.76MHz and/or 622.08MHz clock signal for the STS-12/STM-4 block, then a clock signal of either of the following frequencies, must be applied to this input pin.</p> <ul style="list-style-type: none"> • 12.96MHz • 19.44MHz • 51.84 MHz • 77.76 MHz <p>Afterwards, the appropriate data needs to be written into the Interface Control Register - Byte 2 (Indirect Address = 0x00, 0x31), (Direct Address = 0x0131) in order to;</p> <p>(1) configure the Clock Synthesizer Block to accept any of the above-mentioned signals and generate a 77.76MHz or 622.08MHz clock signal,</p> <p>(2) to configure the Clock Synthesizer to function as the Clock Source for the STS-12/STM-4 block.</p> <p>If Clock Synthesizer is NOT Enabled:</p> <p>If the Transmit STS-12/STSM-4 Clock Synthesizer block is NOT to be used to generate the 77.76MHz and/or 622.08MHz clock signal for the STS-12/STM-4 block, then a 77.76MHz clock signal must be applied to this input pin.</p>
AF6	LOS	I	TTL	<p>Loss of Optical Carrier Input - Primary:</p> <p>The Loss of Carrier output (from the Optical Transceiver) should be connected to this input pin.</p> <p>If this input pin is pulled "High", then the Primary Receive STS-12 TOH Processor block will declare a Loss of Optical Carrier condition.</p> <p>NOTE: This input pin is only active if the Primary Port is active. This input pin is inactive if the Redundant Port is active.</p>

SONET/SDH SERIAL LINE INTERFACE PINS

PIN #	SIGNAL NAME	I/O	SIGNAL TYPE	DESCRIPTION
AE6	LOS-R	I	TTL	<p>Loss of Optical Carrier Input - Redundant:</p> <p>The Loss of Carrier output (from the Optical Transceiver) should be connected to this input pin.</p> <p>If this input pin is pulled "High", then the Redundant Receive STS-12 TOH Processor block will declare a Loss of Optical Carrier condition.</p> <p><i>NOTE: This input pin is only active if the Redundant Port is active. This input pin is inactive if the Primary Port is active.</i></p>
AB7	EXSWITCH	O	CMOS	<p>External (APS) Switch Output Pin:</p> <p>This output pin can be used to permit the XRT94L43 to perform APS externally. Specifically, this output pin can be connected to some circuitry that permits the re-direction of STS-12/STM-4 traffic, should an APS event be needed.</p> <p><i>NOTE: This output pin is disabled if the EXSWITCHDIS input pin number AB6 is pulled "High".</i></p>
AB6	EXSWITCHDIS	I	TTL	<p>External (APS) Switch Disable:</p> <p>This input pin permits the user to configure the XRT94L43 to perform Line APS Switching internally or externally.</p> <p>0 - Configures the XRT94L43 to perform APS externally. In this mode, the XRT94L43 will execute an APS by toggling the state of the "EXSWITCH" output pin.</p> <p>1 - Configures the XRT94L43 to perform APS internally. In this mode, each of the 12 Receive SONET POH Processor blocks (within the XRT94L43) will internally switch from processing the incoming STS-1 SPE data from the "Primary" Receive STS-12 TOH Processor block, to now processing the incoming STS-1 SPE data from the "Redundant" Receive STS-12 TOH Processor block (or vice-versa).</p>

STS-12/STM-4 TELECOM BUS INTERFACE - TRANSMIT DIRECTION

PIN #	SIGNAL NAME	I/O	SIGNAL TYPE	DESCRIPTION
G2	TXA_CLK	O	CMOS	<p>STS-12/STM-4 Transmit Telecom Bus Clock Signal:</p> <p>This output clock signal functions as the clock source for the STS-12/STM-4 Transmit Telecom Bus. All output signals (on the Transmit STS-12/STM-4 Telecom Bus) are updated upon the rising edge of this clock signal.</p> <p>This clock signal operates at 77.76MHz and is derived from the Transmit Clock Synthesizer block.</p>
J1	TXA_C1J1	O	CMOS	<p>STS-12/STM-4 Transmit Telecom Bus - C1/J1 Byte Phase Indicator Output Signal:</p> <p>This output pin pulses "High" under the following two conditions.</p> <ol style="list-style-type: none"> Whenever the C1 byte is being output via the TxA_D[7:0] output, and Whenever the J1 byte is being output via the TxA_D[7:0] output. <p>NOTES:</p> <ol style="list-style-type: none"> The STS-12/STM-4 Transmit Telecom Bus will indicate that it is transmitting the C1 byte (via the TxA_D[7:0] output pins), by pulsing this output pin "High" (for one period of TXA_CLK) and keeping the TXA_PL output pin pulled "Low". The STS-12/STM-4 Transmit Telecom Bus will indicate that it is transmitting the J1 byte (via the TxA_D[7:0] output pins), by pulsing this output pin "High" (for one period of TXA_CLK) while the TXA_PL output pin is pulled "High". This output pin is only active if the STS-12/STM-4 Telecom Bus is enabled.
J3	TXA_ALARM	O	CMOS	<p>Transmit STS-12/STM-4 Telecom Bus - Alarm Indicator Output signal:</p> <p>This output pin pulses "High", corresponding to any STS-1 signal (that is being output via the TxA_D[7:0] output pins) is carrying the AIS-P indicator.</p> <p>This output pin is "Low" for all other conditions.</p>
H1	TXA_DP	O	CMOS	<p>STS-12/STM-4 Transmit Telecom Bus - Parity Output Pin:</p> <p>This output pin can be configured to function as one of the following.</p> <ol style="list-style-type: none"> The EVEN or ODD parity value of the bits which are output via the TxA_D[7:0] output pins. The EVEN or ODD parity value of the bits which are being output via the TxA_D[7:0] output pins and the states of the TXA_PL and TXA_C1J1 output pins. <p>NOTE: Any one of these configuration selections can be made by writing the appropriate value into the Telecom Bus Control Register (Indirect Address = 0x00, 0x37), (Direct Address = 0x0137)..</p>

STS-12/STM-4 TELECOM BUS INTERFACE - TRANSMIT DIRECTION

PIN #	SIGNAL NAME	I/O	SIGNAL TYPE	DESCRIPTION
K5	TxSBFP	I	TTL	<p>Telecom Bus Sync Reference Input: If either the STS-12/STM-4 or any of the STS-3/STM-1 Telecom Bus Interfaces are enabled, then an 8kHz pulse must be applied to this input pin.</p> <p>If the STS-12/STM-4 Telecom Bus Interface is enabled: The Transmit STS-12/STM-4 Telecom Bus Interface will begin transmitting the very first byte of given STS-12 or STM-4 frame, upon sensing a rising edge (of the 8kHz signal) at this input pin.</p> <p>If any of the STS-3/STM-1 Telecom Bus Interfaces are enabled: The Receive STS-3/STM-1 Telecom Bus Interfaces will begin transmitting the very first byte of a given STS-3 or STM-1 frame, upon sensing a rising edge (of the 8kHz signal) at this input pin.</p> <p>NOTE: <i>If none of the Telecom Bus Interfaces are used, then this pin should be tied to GND.</i></p> <p>NOTES:</p> <ol style="list-style-type: none"> 1. <i>If this input pin is tied to GND, then the Transmit STS-12 TOH Processor block will generate its outbound STS-12/STM-4 frames asynchronously with respect to any input signal.</i> 2. <i>This input signal must be synchronized with the signal that is supplied to the REFCLK input pin. Failure to insure this will result in bit errors being generated within the outbound STS-12/STM-4 signal.</i> 3. <i>An 8kHz pulse must be applied to this input pin, that has a width of approximately 12.8ns (one 77.76MHz clock period). Do not apply a 50% duty cycle 8kHz signal to this input pin.</i>

STS-12/STM-4 TELECOM BUS INTERFACE - TRANSMIT DIRECTION

PIN #	SIGNAL NAME	I/O	SIGNAL TYPE	DESCRIPTION
F3	TxA_PL	O	CMOS	<p>STS-12/STM-4 Transmit Telecom Bus - Payload Data Indicator Signal:</p> <p>This output pin indicates whether or not TOH (Transmit Overhead) bytes are being output via the TXA_D[7:0] output pins.</p> <p>This output pin is pulled "Low" for the duration that the STS-12/STM-4 Transmit Telecom Bus is transmitting a Transport Overhead byte via the TXA_D[7:0] output pins.</p> <p>Conversely, this output pin is pulled "High" for the duration that the STS-12/STM-4 Transmit Telecom Bus is transmitting something other than a Transport Overhead (e.g., the POH or STS-1/STS-3c SPE bytes) byte via the TXA_D[7:0] output pins.</p>
G1 J5 J2 H5 E1 F2 F1 E3	TxA_D0 TxA_D1 TxA_D2 TxA_D3 TxA_D4 TxA_D5 TxA_D6 TxA_D7	O	CMOS	<p>STS-12/STM-4 Transmit Telecom Bus - Transmit Output Data Bus pins:</p> <p>These 8 output pins function as the "STS-12/STM-4 Transmit Telecom Bus" Transmit Output data bus. If the STS-12/STM-4 Telecom Bus Interface is enabled, then all STS-12/STM-4 data is output via these pins (in a byte-wide manner), upon the rising edge of the TXA_CLK output pin.</p> <p>NOTES:</p> <ol style="list-style-type: none"> The pin TXA_D7 will output the MSB (Most Significant Bit) of each byte that is output via the Transmit STS-12/STM-4 Telecom Bus Interface. The pin TXA_D0 will output the LSB (Least Significant Bit) of each byte that is output via the Transmit STS-12/STM-4 Telecom Bus Interface.

STS-12/STM-4 TELECOM BUS INTERFACE - RECEIVE DIRECTION

PIN #	SIGNAL NAME	I/O	SIGNAL TYPE	DESCRIPTION
V4	RxD_CLK	I	TTL	<p>Receive STS-12/STM-4 Telecom Bus Interface - Clock Input Signal:</p> <p>This input clock signal functions as the clock source for the Receive STS-12/STM-4 Telecom Bus Interface. All Receive STS-12/STM-4 Telecom Bus Interface input signals are sampled upon the rising edge of this input clock signal.</p> <p>This clock signal should operate at 77.76MHz.</p> <p>NOTE: This input pin is only used if the STS-12/STM-4 Telecom Bus has been enabled. It should be tied to GND otherwise.</p>
U5	RxD_PL	I	TTL	<p>Receive STS-12/STM-4 Telecom Bus Interface - Payload Indicator Signal:</p> <p>This input pin indicates whether or not STS-1/STS-3c SPE bytes are being input via the RXD_D[7:0] input pins.</p> <p>This input pin should be pulled "High" coincident to whenever the Receive STS-12/STM-4 Telecom Bus Interface block is receiving STS-1/STS-3c SPE data bytes via the RXD_D[7:0] input pins.</p> <p>Conversely, this input pin should be pulled "Low" coincident to whenever the Receive STS-12/STM-4 Telecom Bus Interface block is receiving something other than an STS-1/STS-3c SPE byte (e.g., a TOH byte) via the RXD_D[7:0] input pins.</p> <p>NOTE: The user should tie this pin to GND if the STS-12/STM-4 Telecom Bus Interface is configured to operate in the "Re-Phase ON" Mode or is disabled.</p>
V2	RxD_C1J1	I	TTL	<p>STS-12/STM-4 Receive Telecom Bus C1/J1 Byte Phase Indicator Input Signal:</p> <p>This input pin should be pulsed "High" during both of the following conditions.</p> <ol style="list-style-type: none"> 1. Whenever the C1 byte is being input to the Receive STS-12/STM-4 Telecom Bus Interface - Data Bus Input pins (RXD_D[7:0]). 2. Whenever the J1 byte is being input to the Receive STS-12/STM-4 Telecom Bus Interface -Data Bus Input pins (RXD_D[7:0]). <p>This input pin should be pulled "low" for all other times.</p> <p>NOTE: Tie this pin to GND if the STS-12/STM-4 Telecom Bus is NOT enabled.</p>

STS-12/STM-4 TELECOM BUS INTERFACE - RECEIVE DIRECTION

PIN #	SIGNAL NAME	I/O	SIGNAL TYPE	DESCRIPTION
U4	RxD_DP	I	TTL	<p>STS-12/STM-4 Receive Telecom Bus - Parity Input Pin:</p> <p>This input pin can be configured to function as one of the following.</p> <ol style="list-style-type: none"> 1. The EVEN or ODD parity value of the bits which are input via the RxD_D[7:0] input pins. 2. The EVEN or ODD parity value of the bits which are being input via the RxD_D[7:0] input and the states of the RxD_PL and RxD_C1J1 input pins. <p>The Receive STS-12/STM-4 Telecom Bus Interface will use this pin to compute and verify the parity within the incoming STS-12/STM-4 data-stream.</p> <p>NOTES:</p> <ol style="list-style-type: none"> 1. Any one of these configuration selections can be made by writing the appropriate value into the Telecom Bus Control register (Indirect Address = 0x00, 0x37, direct Address = 0x0137). 2. Tie this pin to GND if the STS-12/STM-4 Telecom Bus Interface is configured to operate in the Re-Phase ON Mode or is disabled.
T2	RxD_ALARM	I	TTL	<p>Receive STS-12/STM-4 Telecom Bus - Alarm Indicator Input:</p> <p>This input pin pulses "High" corresponding to any STS-1 signal that is carrying the AIS-P indicator.</p> <p>More specifically, this input pin will be pulsed "High" coincident to whenever a byte, corresponding to given STS-1 signal (that is carrying the AIS-P indicator) is being placed on the Receive STS-12/STM-4 Telecom Bus - Data Bus Input pins (RxD_D[7:0]). This input pin should be pulled "Low" at all other times.</p> <p>NOTES:</p> <ol style="list-style-type: none"> 1. If the RxD_ALARM input signal pulses "High" for any given STS-1 signal (within the incoming STS-12), then the XRT94L43 will automatically declare the AIS-P defect for that particular STS-1 channel. 2. Tie this pin to GND if the STS-12/STM-4 Telecom Bus Interface has been configured to operate in the Re-Phase On Mode or is disabled.
U3 V3 U2 T1 V5 U1 W1 V1	RxD_D0 RxD_D1 RxD_D2 RxD_D3 RxD_D4 RxD_D5 RxD_D6 RxD_D7	I	TTL	<p>Receive STS-12/STM-4 Receive Telecom Bus - Receive Input Data Bus pins:</p> <p>These 8 input pins function as the "Receive STS-12/STM4 Receive Telecom Bus" Receive Input data bus. All incoming STS-12/STM-4 data is sampled and latched (into the XRT94L43 via these input pins) upon the rising edge of the RxD_CLK" input pin.</p> <p>NOTES:</p> <ol style="list-style-type: none"> 1. The user must insure that the MSB (Most Significant bit) of each incoming byte is input to the RxD_D7 input pin. 2. The user must also insure that the LSB (Least Significant bit) of each incoming byte is input to the RxD_D0 input pin. 3. The user should tie these pins to GND if the STS-12/STM-4 Telecom Bus is not enabled.

SONET/SDH OVERHEAD INTERFACE - TRANSMIT DIRECTION

PIN #	SIGNAL NAME	I/O	SIGNAL TYPE	DESCRIPTION
H2	TxTOHClk	O	CMOS	<p>Transmit TOH Input Port - Clock Output:</p> <p>This output pin, along with the TxTOHEnable, TxTOHFrame output pins and the TxTOH and TxTOHIns input pins function as the Transmit TOH Input Port.</p> <p>The Transmit TOH Input Port allows the user to insert their own value for the TOH bytes (in the outbound STS-12/STM-4 signal).</p> <p>This output pin provides a clock signal. If the TxTOHEnable output pin is "High" and if the TxTOHIns input pin is pulled "High", then the user is expected to provide a given bit (within the TOH) to the TxTOH input pin, upon the falling edge of this clock signal. The data, residing on the TxTOH input pin will be latched into the XRT94L43 upon the rising edge of this clock signal.</p> <p>NOTE: The Transmit TOH Input Port only support the insertion of the TOH within the first STS-1, within the outbound STS-12 signal.</p>
H4	TxTOHEnable	O	CMOS	<p>Transmit TOH Input Port - TOH Enable (or READY) indicator:</p> <p>This output pin, along with the TxTOHClk, TxTOHFrame output pins and the TxTOH and TxTOHIns input pins function as the Transmit TOH Input Port.</p> <p>This output pin will toggle and remain "High" anytime the Transmit TOH Input Port is ready to externally accept TOH data.</p> <p>If it is desired to externally insert a value of TOH into the outbound STS-12 data stream via the Transmit TOH Input Port, then do the following:</p> <ul style="list-style-type: none"> • Continuously sample the state of TxTOHFrame and this output pin upon the rising edge of TxTOHClk. • Whenever this output pin pulses "High", then the user's external circuitry should drive the TxTOHIns input pin "High". • Next, the user should output the next TOH bit, onto the TxTOH input pin, upon the falling edge of TxTOHClk.
D1	TxTOH	I	TTL	<p>Transmit TOH Input Port - Input Pin:</p> <p>This input pin, along with the TxTOHIns input pin, the TxTOHEnable and TxTOHFrame and TxTOHClk output pins function as the Transmit TOH Input Port.</p> <p>If it is desired to externally insert a value of TOH into the outbound STS-12 data stream via the Transmit TOH Input Port, then do the following:</p> <ul style="list-style-type: none"> • Continuously sample the state of TxTOHFrame and TxTOHEnable upon the rising edge of TxTOHClk. • Whenever TxTOHEnable pulses "High", then the user's external circuitry should drive the TxTOHIns input pin "High". • Next, the user should output the next TOH bit, onto this input pin, upon the falling edge of TxTOHClk. The Transmit TOH Input Port will sample the data (on this input pin) upon the rising edge of TxTOHClk. <p>NOTE: Data at this input pin will be ignored (e.g., not sampled) unless the TxTOHEnable output pin is "High" and the TxTOHIns input pin is pulled "High".</p>

SONET/SDH OVERHEAD INTERFACE - TRANSMIT DIRECTION

PIN #	SIGNAL NAME	I/O	SIGNAL TYPE	DESCRIPTION
G4	TxTOHFrame	O	CMOS	<p>Transmit TOH Input Port - STS-12/STM-4 Frame Indicator:</p> <p>This output pin, along with TxTOHCk, TxTOHEnable output pins, and the TxTOH and TxTOHIns input pins function as the Transmit TOH Input Port.</p> <p>This output pin will pulse "High" (for one period of TxTOHCk), one TxTOHCk clock period prior to the first TOH bit of a given STS-12 frame, being expected via the TxTOH input pin.</p> <p>If it is desired to externally insert a value of TOH into the outbound STS-12 data stream via the Transmit TOH Input Port, then do the following:</p> <ul style="list-style-type: none"> • Continuously sample the state of TxTOHEnable and this output pin upon the rising edge of TxTOHCk. • Whenever the TxTOHEnable output pin pulse "High", then the user's external circuitry should drive the TxTOHIns input pin "High". • Next, the user should output the next TOH bit, onto the TxTOH input pin, upon the falling edge of TxTOHCk. <p>NOTE: The external circuitry (which is being interfaced to the Transmit TOH Input Port can use this output pin to denote the boundary of STS-12 frames.</p>
C1	TxTOHIns	I	TTL	<p>Transmit TOH Input Port - Insert Enable Input Pin:</p> <p>This input pin, along with the TxTOH input pin, and the TxTOHEnable, TxTOHFrame and TxTOHCk output pins function as the Transmit TOH Input Port.</p> <p>This input pin is used to either enable or disable the Transmit TOH Input Port.</p> <p>If this input pin is "Low", then the Transmit TOH Input Port will be disabled and will not sample and insert (into the outbound STS-12 data stream) any data residing on the TxTOH input, upon the rising edge of TxTOHCk.</p> <p>If this input pin is "High", then the Transmit TOH Input Port will be enabled. In this mode, whenever the TxTOHEnable output pin is also "High", the Transmit TOH Input Port will sample and latch any data that is presented on the TxTOH input pin, upon the rising edge of TxTOHCk.</p> <p>If it is desired to externally insert a value of TOH into the outbound STS-12 data stream via the Transmit TOH Input Port, then do the following:</p> <ul style="list-style-type: none"> • Continuously sample the state of TxTOHFrame and TxTOHEnable upon the rising edge of TxTOHCk. • Whenever the TxTOHEnable output pin is sampled "High" then the user's external circuitry should drive this input pin "High". • Next, the user should output the next TOH bit, onto the TxTOH input pin, upon the falling edge of TxTOHCk. The Transmit TOH Input Port will sample the data (on this input pin) upon the rising edge of TxTOHCk. <p>NOTE: Data applied to the TxTOH input pin will be ignored (e.g., not sampled) unless then the TxTOHEnable and this input pin are each "High".</p>

SONET/SDH OVERHEAD INTERFACE - TRANSMIT DIRECTION

PIN #	SIGNAL NAME	I/O	SIGNAL TYPE	DESCRIPTION
G3	TxDCCEnable	O	CMOS	<p>Transmit - Line DCC Input Port - Enable Output Pin:</p> <p>This output pin, along with the TxTOHClk output pin and the TxLDCC input pin are used to insert the value for the D4, D5, D6, D7, D8, D9, D10, D11 and D12 bytes into the Transmit STS-12 TOH Processor Block. The Transmit STS-12 TOH Processor block will accept this data and will insert into the D4, D5, D6, D7, D8, D9, D10, D11 and D12 byte-fields, within the outbound STS-12 data-stream.</p> <p>The Line DCC HDLC Controller circuitry (which is connected to the TxTOHClk, the TxLDCC and this output pin, is suppose to do the following.</p> <ol style="list-style-type: none"> 1. It should continuously monitor the state of this output pin. 2. Whenever this output pin pulses "High", then the Line DCC HDLC Controller circuitry should place the next Line DCC bit (to be inserted into the Transmit STS-12 TOH Processor block) onto the TxLDCC input pin, upon the falling edge of TxTOHClk. 3. Any data that is placed on the TxLDCC input pin, will be sampled upon the rising edge of TxOHClk.
J4	TxDCCEnable	O	CMOS	<p>Transmit - Section DCC Input Port - Enable Output Pin:</p> <p>This output pin, along with the TxTOHClk output pin and the TxSDCC input pin are used to insert the value for the D1, D2 and D3 bytes, into the Transmit STS-12 TOH Processor Block. The Transmit STS-12 TOH Processor block will accept this data and will insert into the D1, D2 and D3 byte-fields, within the outbound STS-12 data-stream.</p> <p>The Section DCC HDLC Controller circuitry (which is connected to the TxTOHClk, the TxSDCC and this output pin, is suppose to do the following.</p> <ol style="list-style-type: none"> 1. It should continuously monitor the state of this output pin. 2. Whenever this output pin pulses "High", then the Section DCC HDLC Controller circuitry should place the next Section DCC bit (to be inserted into the Transmit STS-12 TOH Processor block) onto the TxSDCC input pin, upon the falling edge of TxTOHClk. 3. Any data that is placed on the TxSDCC input pin, will be sampled upon the rising edge of TxOHClk.
E2	TxDCC	I	TTL	<p>Transmit - Section DCC Input Port - Input Pin:</p> <p>This input pin, along with the TxSDCCEnable and the TxTOHClk output pins are used to insert a value for the D1, D2 and D3 bytes, into the Transmit STS-12 TOH Processor Block. The Transmit STS-12 TOH Processor block will accept this data and insert it into the D1, D2 and D3 byte fields, within the outbound STS-12 data-stream.</p> <p>The Section DCC HDLC Circuitry that is interfaced to this input pin, the TxSDCCEnable and the TxTOHClk pins is suppose to do the following.</p> <ol style="list-style-type: none"> 1. It should continuously monitor the state of the TxSDCCEnable input pin. 2. Whenever the TxSDCCEnable input pin pulses "High", then the Section DCC HDLC Controller circuitry should place the next Section DCC bit (to be inserted into the Transmit STS-12 TOH Processor block) onto this input pin upon the falling edge of TxTOHClk. 3. Any data that is placed on the TxSDCC input pin, will be sampled upon the rising edge of TxTOHClk. <p>NOTE: Tie this pin to GND if it is not going to be used.</p>

SONET/SDH OVERHEAD INTERFACE - TRANSMIT DIRECTION

PIN #	SIGNAL NAME	I/O	SIGNAL TYPE	DESCRIPTION
H3	TxDCC	I	TTL	<p>Transmit - Line DCC Input Port:</p> <p>This input pin, along with the TxLDCCEnable and the TxTOHClk pins are used to insert a value for the D4, D5, D6, D7, D8, D9, D10, D11 and D12 bytes, into the Transmit STS-12 TOH Processor Block. The Transmit STS-12 TOH Processor block will accept this data and insert it into the D4, D5, D6, D7, D8, D9, D10, D11 and D12 byte-fields, within the outbound STS-12 data-stream.</p> <p>Whatever Line DCC HDLC Controller Circuitry is interface to the this input pin, the TxLDCCEnable and the TxTOHClk is suppose to do the following.</p> <ol style="list-style-type: none"> 1. It should continuously monitor the state of the TxLDCCEnable input pin. 2. Whenever the TxLDCCEnable input pin pulses "High", then the Section DCC Interface circuitry should place the next Line DCC bit (to be inserted into the Transmit STS-12 TOH Processor block) onto the TxLDCC input pin, upon the falling edge of TxTOHClk. 3. Any data that is placed on the TxLDCC input pin, will be sampled upon the rising edge of TxTOHClk. <p>NOTE: Tie this pin to GND, if it is not going to be used.</p>
F4	TxE1F1E2Enable	O	CMOS	<p>Transmit E1-F1-E2 Byte Input Port - Enable (or Ready) Indicator Output Pin:</p> <p>This output pin, along with the TxTOHClk output pin and the TxE1F1E2 input pin are used to insert a value for the E1, F1 and E2 bytes, into the Transmit STS-12 TOH Processor Block. The Transmit STS-12 TOH Processor block will accept this data and will insert into the E1, F1 and E2 byte-fields, within the outbound STS-12 data-stream.</p> <p>Whatever external circuitry (which is connected to the TxTOHClk, the TxE1F1E2 and this output pin, is suppose to do the following.</p> <ol style="list-style-type: none"> 1. It should continuously monitor the state of this output pin. 2. Whenever this output pin pulses "High", then the external circuitry should place the next orderwire bit (to be inserted into the Transmit STS-12 TOH Processor block) onto the TxE1F1E2 input pin, upon the falling edge of TxTOHClk. <p>Any data that is placed on the TxE1F1E2 input pin, will be sampled upon the rising edge of TxOHClk.</p>
D2	TxE1F2E2Frame	O	CMOS	<p>Transmit E1-F1-E2 Byte Input Port - Framing Output Pin:</p> <p>This output pin pulses "High" for one period of TxTOHClk, one TxTOHClk bit-period prior to the Transmit E1-F1-E2 Byte Input Port expecting the very first byte of the E1 byte, within a given outbound STS-12 frame.</p>

SONET/SDH OVERHEAD INTERFACE - TRANSMIT DIRECTION

PIN #	SIGNAL NAME	I/O	SIGNAL TYPE	DESCRIPTION
J6	TxE1F1E2	I	TTL	<p>Transmit E1-F1-E2 Byte Input Port - Input Pin:</p> <p>This input pin, along with the TxE1F1E2Enable and the TxTOHClk output pins are used to insert a value for the E1, F1 and E2 bytes, into the Transmit STS-12 TOH Processor Block. The Transmit STS-12 TOH Processor block will accept this data and insert it into the E1, F1 and E2 byte fields, within the outbound STS-12 data-stream.</p> <p>Whatever external circuitry that is interfaced to this input pin, the TxE1F1E2Enable and the TxTOHClk pins is suppose to do the following.</p> <ol style="list-style-type: none"> 1. It should continuously monitor the state of the TxE1F1E2Enable input pin. 2. Whenever the TxE1F1E2Enable input pin pulses "High", then the external circuitry should place the next orderwire bit (to be inserted into the Transmit STS-12 TOH Processor block) onto this input pin upon the falling edge of TxTOHClk. 3. Any data that is placed on the TxE1F1E2 input pin, will be sampled upon the rising edge of TxTOHClk. <p>NOTE: Tie this pin to GND if it is not going to be used.</p>

SONET/SDH OVERHEAD INTERFACE - TRANSMIT DIRECTION

PIN #	SIGNAL NAME	I/O	SIGNAL TYPE	DESCRIPTION
C10 B13 AD12 AD8 A16 D18 AD13 AE8 D13 C18 AE17 AB12 D9 C13 AE11 AF4	TxPOH_0 TxPOH_1 TxPOH_2 TxPOH_3 TxPOH_4 TxPOH_5 TxPOH_6 TxPOH_7 TxPOH_8 TxPOH_9 TxPOH_10 TxPOH_11 TxPOH_12 TxPOH_13 TxPOH_14 TxPOH_15	I	TTL	<p>Transmit Path Overhead Input Port - Input Pin.</p> <p>These input pins allow the following actions.</p> <ol style="list-style-type: none"> 1. Insertion of the POH data into each of the 12 Transmit SONET POH Processor blocks (for insertion and transmission via the outbound STS-12 signal). 2. Insertion of the POH data into each of the 12 Transmit STS-1 POH Processor blocks (for insertion and transmission via each of the outbound STS-1 signals). 3. Insertion of the TOH data into each of the 12 Transmit STS-1 TOH Processor blocks (for insertion and transmission via each of the outbound STS-1 signals). <p>The function of these input pins, depends upon whether or not the TOH data is inserted into the 12 Transmit STS-1 TOH Processor blocks.</p> <p>If the user is only inserting POH data via these input pins:</p> <p>In this mode, the external circuitry (which is being interfaced to the Transmit Path Overhead Input Port is suppose to monitor the following output pins.</p> <ul style="list-style-type: none"> • TxPOHFrame_n • TxPOHEnable_n • TxPOHClk_n <p>The TxPOHFrame_n output pin will toggle "High" upon the falling edge of TxPOHClk_n approximately one TxPOHClk_n period prior to the TxPOH port being ready to accept and process the first bit within the J1 byte (e.g., the first POH byte). The TxPOHFrame_n output pin will remain "High" for eight consecutive TxPOHClk_n periods. The external circuitry should use this pin to note STS-1 SPE frame boundaries.</p> <p>The TxPOHEnable_n output pin will toggle "High" upon the falling edge of TxPOHClk_n approximately one TxPOHClk_n period prior to the TxPOH port being ready to accept and process the first bit within a given POH byte.</p> <p>To externally insert a given POH byte, (1) assert the TxPOHIns_n input pin by toggling it "High" and (2) place the value of the first bit (within this particular POH byte) on this input pin upon the very next falling edge of TxPOHClk_n. This data bit will be sampled upon the very next rising edge of TxPOHClk_n. The external circuitry should continue to keep the TxPOHIns_n input pin "High" and advancing the next bits (within the POH bytes) upon each falling edge of TxPOHClk_n.</p> <p>If the user is inserting both POH and TOH data via these input pins:</p> <p>In this mode, the external circuitry (which is being interfaced to the Transmit Path Overhead Input Port is suppose to monitor the following output pins.</p> <ul style="list-style-type: none"> • TxPOHFrame_n • TxPOHEnable_n • TxPOHClk_n <p>(continued below)</p>

SONET/SDH OVERHEAD INTERFACE - TRANSMIT DIRECTION

PIN #	SIGNAL NAME	I/O	SIGNAL TYPE	DESCRIPTION
C10 B13 AD12 AD8 A16 D18 AD13 AE8 D13 C18 AE17 AB12 D9 C13 AE11 AF4	TxPOH_0 TxPOH_1 TxPOH_2 TxPOH_3 TxPOH_4 TxPOH_5 TxPOH_6 TxPOH_7 TxPOH_8 TxPOH_9 TxPOH_10 TxPOH_11 TxPOH_12 TxPOH_13 TxPOH_14 TxPOH_15	I	TTL	<p>If the user is inserting both POH and TOH data via these input pins:</p> <p>(Continued)</p> <p>The TxPOHFrame_n output pin will toggle "High" twice during a given STS-1 frame period. First, this output pin will toggle "High" coincident with the TxPOH port being ready to accept and process the A1 byte (e.g., the very first TOH byte). Second, this output pin will toggle "High" coincident with the TxPOH port being ready to accept and process the J1 byte (e.g., the very first POH byte).</p> <p>If the externally circuitry samples the TxPOHFrame_n output pin "High", and the TxPOHEnable_n output pin "Low", then the TxPOH port is now ready to accept and process the very first TOH byte.</p> <p>If the externally circuitry samples the TxPOHFrame_n output pin "High" and the TxPOHEnable_n output pin "High", then the TxPOH port is now ready to accept and process the very first POH byte.</p> <p>To externally insert a given POH or TOH byte, do the following;</p> <ol style="list-style-type: none"> (1) Assert the TxPOHIns_n input pin by toggling it "High" and, (2) place the value of the first bit (within this particular POH or TOH byte) on this input upon the very next falling edge of TxPOHClk_n. <p>This data bit will be sampled upon the very next rising edge of TxPOHClk_n. The external circuitry should continue to keep the TxPOHIns_n input pin "High" and advancing the next bits (within the POH bytes) upon each falling edge of TxPOHClk_n.</p> <p>NOTES:</p> <ol style="list-style-type: none"> 1. If POH data is externally inserted into each of the 12 Transmit SONET POH Processor blocks, then these input pins cannot be used to externally insert POH data into each of the 12 Transmit STS-1 POH Processor blocks. 2. TOH data can be externally inserted into each of the 12 Transmit STS-1 TOH Processor blocks, only if POH data is NOT externally inserted into each of the 12 Transmit SONET POH Processor blocks.
B10 A15 AC13 AD9 B16 D19 AE13 AE9 D14 C19 AF19 AB13 E10 C14 AF11 AF5	TxPOHClk_0 TxPOHClk_1 TxPOHClk_2 TxPOHClk_3 TxPOHClk_4 TxPOHClk_5 TxPOHClk_6 TxPOHClk_7 TxPOHClk_8 TxPOHClk_9 TxPOHClk_10 TxPOHClk_11 TxPOHClk_12 TxPOHClk_13 TxPOHClk_14 TxPOHClk_15	O	CMOS	<p>Transmit Path Overhead Input Port - Clock Output pin:</p> <p>These output pins, along with TxPOH_n, TxPOHEnable_n, TxPOHIns_n and TxPOHFrame_n function as the Transmit Path Overhead (TxPOH) Input Port.</p> <p>The TxPOHFrame_n and TxPOHEnable_n output pins are updated upon the falling edge this clock output signal. The TxPOHIns_n input pins and the data residing on the TxPOH_n input pins are sampled on the rising edge of this clock signal.</p>

SONET/SDH OVERHEAD INTERFACE - TRANSMIT DIRECTION

PIN #	SIGNAL NAME	I/O	SIGNAL TYPE	DESCRIPTION
A6	TxPOHFrame_0	O	CMOS	<p>Transmit Path Overhead Input Port - Frame Output pin:</p> <p>These output pins, along with the TxPOH_n, TxPOHEnable_n, TxPOHIns_n and TxPOHCik_n function as the Transmit Path Overhead Input Port.</p> <p>The function of these output pins depends upon whether POH or TOH data is inserted via the TxPOH_n input pins.</p> <p>If the user is only inserting POH data via these input pins:</p> <p>In this mode, the TxPOH port will pulse these output pins "High" whenever it is ready to accept and process the J1 byte (e.g., the very first POH byte) via this port.</p> <p>If the user is inserting both POH and TOH data via these input pins:</p> <p>In this mode, the TxPOH port will pulse these output pins "High" coincident with the following.</p> <ol style="list-style-type: none"> Whenever the TxPOH port is ready to accept and process the A1 byte (e.g., the very first TOH byte) via this port. Whenever the TxPOH port is ready to accept and process the J1 byte (e.g., the very first POH byte) via this port. <p>NOTE: The external circuitry can determine whether the TxPOH port is expecting the A1 byte or the J1 byte, by checking the state of the corresponding TxPOHEnable output pin. If the TxPOHEnable_n output pin is "Low" while the TxPOHFrame_n output pin is "High", then the TxPOH port is ready to process the A1 (TOH) bytes.</p> <p>If the TxPOHEnable_n output pin is "High" while the TxPOHFrame_n output pin is "High", then the TxPOH port is ready to process the J1 (POH) bytes.</p>
A11	TxPOHFrame_1			
AC12	TxPOHFrame_2			
AD7	TxPOHFrame_3			
D8	TxPOHFrame_4			
B12	TxPOHFrame_5			
AF14	TxPOHFrame_6			
AB10	TxPOHFrame_7			
A12	TxPOHFrame_8			
C17	TxPOHFrame_9			
AA15	TxPOHFrame_10			
AC10	TxPOHFrame_11			
D7	TxPOHFrame_12			
E11	TxPOHFrame_13			
AC11	TxPOHFrame_14			
AD6	TxPOHFrame_15			

SONET/SDH OVERHEAD INTERFACE - TRANSMIT DIRECTION

PIN #	SIGNAL NAME	I/O	SIGNAL TYPE	DESCRIPTION
A7 C12 AE12 AC9 E9 A13 AF16 AB11 E13 D17 AC16 AF8 E8 E12 AF9 AC8	TxPOHIns_0 TxPOHIns_1 TxPOHIns_2 TxPOHIns_3 TxPOHIns_4 TxPOHIns_5 TxPOHIns_6 TxPOHIns_7 TxPOHIns_8 TxPOHIns_9 TxPOHIns_10 TxPOHIns_11 TxPOHIns_12 TxPOHIns_13 TxPOHIns_14 TxPOHIns_15	I	TTL	<p>Transmit Path Overhead Input Port - Insert Enable Input pin:</p> <p>These input pins, along with TxPOH_n, TxPOHEnable_n, TxPOHFrame_n and TxPOHClk_n function as the Transmit Path Overhead (TxPOH) Input Port.</p> <p>These input pins are used to enable or disable the TxPOH input port. If these input pins are pulled "High", then the TxPOH port will sample and latch data via the corresponding TxPOH input pins, upon the rising edge of TxPOHClk_n.</p> <p>Conversely, if these input pins are pulled "Low", then the TxPOH port will NOT sample and latch data via the corresponding TxPOH input pins.</p> <p>NOTE: If the TxPOHIns_n input pin is pulled "Low", this setting will be overridden if, the Transmit SONET/STS-1 POH Processor or Transmit STS-1 TOH Processor blocks are configured to accept certain POH or TOH overhead bytes via the external port.</p>
D10 D15 AB14 AE7 A10 A17 AC14 AF7 C11 B14 AD14 AE10 B11 D16 AF13 AB9	TxPOHEnable_0 TxPOHEnable_1 TxPOHEnable_2 TxPOHEnable_3 TxPOHEnable_4 TxPOHEnable_5 TxPOHEnable_6 TxPOHEnable_7 TxPOHEnable_8 TxPOHEnable_9 TxPOHEnable_10 TxPOHEnable_11 TxPOHEnable_12 TxPOHEnable_13 TxPOHEnable_14 TxPOHEnable_15	O	CMOS	<p>Transmit Path Overhead Input Port - POH Indicator Output pin:</p> <p>These output pins, along with TxPOH_n, TxPOHIns_n, TxPOHFrame_n and TxPOHClk_n function as the Transmit Path Overhead (TxPOH) Input Port.</p> <p>These output pins will pulse "High" anytime the TxPOH port is ready to accept and process POH bytes. These output pins will be "Low" at all other times.</p>

STS-3/STM-1 TELECOM BUS INTERFACE - TRANSMIT DIRECTION

PIN #	SIGNAL NAME	I/O	SIGNAL TYPE	DESCRIPTION
E15	STS3TxA_CLK_0 TxSBCLK_0 DMO_0	I	TTL	<p>STS-3 Transmit Telecom Bus Clock Input/STM-1 Sub-Rate Clock/DMO_0 (General Purpose) input Pin: The function of this input pin depends upon whether or not the STS-3/STM-1 Telecom Bus Interface for Channel 0 has been enabled.</p> <p>If STS-3/STM-1 Telecom Bus (Channel 0) has been enabled - STS-3 Transmit Telecom Bus Transmit Clock Input - Channel 0: This input clock signal functions as the clock source for the STS-3/STM-1 Transmit Telecom Bus, associated with Channel 0. All input signals (e.g., STS3TxA_ALARM_0, STS3TxA_D_0[7:0], STS3TxA_DP_0, STS3TxA_PL_0, STS3TxA_C1J1_0) are sampled upon the falling edge of this input clock signal. This clock signal should operate at 19.44MHz.</p> <p>If STS-3/STM-1 Telecom Bus (Channel 0) is disabled - DMO_0 (General Purpose) Input Pin: This input pin can be used as a general purpose input pin. The state of this input pin can be determined by reading the state of Bit 2 (DMO) within the Line Interface Scan Register associated with Channel 0 (Address = 0x1E, 0x81), (Direct Address = 0x1F81).</p> <p><i>NOTE: For Product Legacy purposes, this pin is called DMO_0, because one possible application is to tie this input pin to a DMO (Drive Monitor Output) output pin, from one of Exar's XRT73L0X/XRT75L0X DS3/E3/STS-1 LIU devices. However, this input pin, and the corresponding register bit can be used for any purpose.</i></p>
C26	STS3TxA_CLK_1 TxSBCLK_1 DMO_1	I	TTL	<p>STS-3 Transmit Telecom Bus Clock Input/STM-1 Sub-Rate Clock/DMO_1 (General Purpose) input Pin: See definition of Pin # E15 above replacing Channel 0 with Channel 1.</p> <p>If STS-3/STM-1 Telecom Bus (Channel 1) has been enabled - STS-3 Transmit Telecom Bus Clock Input - Channel 1:</p> <p>If STS-3/STM-1 Telecom Bus (Channel 1) is disabled - DMO_1 (General Purpose) Input Pin:</p>
AE25	STS3TxA_CLK_2 TxSBCLK_2 DMO_2	I	TTL	<p>STS-3 Transmit Telecom Bus Clock Input/STM-1 Sub-Rate Clock/DMO_2 (General Purpose) input Pin: See definition of Pin # E15 above replacing Channel 0 with Channel 2.</p> <p>If STS-3/STM-1 Telecom Bus (Channel 2) has been enabled - STS-3 Transmit Telecom Bus Transmit Clock Input - Channel 2:</p> <p>If STS-3/STM-1 Telecom Bus (Channel 2) is disabled - DMO_2 - Drive Monitor Output Input (from XRT73L0X LIU IC) - Channel 2:</p>

STS-3/STM-1 TELECOM BUS INTERFACE - TRANSMIT DIRECTION

PIN #	SIGNAL NAME	I/O	SIGNAL TYPE	DESCRIPTION
AD17	STS3TxA_CLK_3 TxSBCLK_3 DMO_3	I	TTL	<p>STS-3 Transmit Telecom Bus Clock Input/STM-1 Sub-Rate Clock/DMO_3 (General Purpose) input Pin: See definition of Pin # E15 above replacing Channel 0 with Channel 3.</p> <p>If STS-3/STM-1 Telecom Bus (Channel 3) has been enabled - STS-3 Transmit Telecom Bus Clock Input - Channel 3:</p> <p>If STS-3/STM-1 Telecom Bus (Channel 3) is disabled - DMO_3 (General Purpose) Input Pin:</p>
E14	STS3TxA_PL_0 TxSBFrame_0 RLOL_0	I	TTL	<p>Transmit STS-3/STM-1 Telecom Bus Interface - Payload Indicator Signal - Channel 0/RLOL_0 (General Purpose) input Pin: The function of this input depends upon whether or not the STS-3/STM-1 Telecom Bus Interface for Channel 0 has been enabled.</p> <p>If STS-3/STM-1 Telecom Bus (Channel 0) has been enabled - Transmit STS-3/STM-1 Telecom Bus Interface - Payload Indicator Signal - Channel 0: This input pin indicates whether or not Transport Overhead (TOH) bytes are being input via the TXA_D_0[7:0] input pins. This input pin should be pulled "Low" for the duration that the STS-3/STM-1 Transmit Telecom Bus is receiving a TOH byte, via the TXA_D_0[7:0] input pins.</p> <p><i>NOTE: This input signal is sampled upon the falling edge of STS3TxA_CLK_0.</i></p> <p>If STS-3/STM-1 Telecom Bus (Channel 0) is disabled - RLOL_0 (General Purpose) Input Pin. This input pin can be used as a general purpose input pin. The state of this input pin can be determined by reading the state of Bit 1 (RLOL) within the Line Interface Scan Register associated with Channel 0 (Address = 0x1E, 0x81), (Direct Address = 0x1F81).</p> <p><i>NOTE: For Product Legacy purposes, this pin is called RLOL_0 because one possible application is to tie this input pin to a RLOL (Receive Loss of Lock) output pin, from one of Exar's XRT73L0X/XRT75L0X DS3/E3/STS-1 LIU devices. However, this input pin and the corresponding register bit can be used for any purpose.</i></p>
A26	STS3TxA_PL_1 TxSBFrame_1 RLOL_1	I	TTL	<p>Transmit STS-3/STM-1 Telecom Bus Interface - Payload Indicator Signal - Channel 1/RLOL_1 (General Purpose) input Pin: See definition of Pin # E14 above replacing Channel 0 with Channel 1.</p> <p>If STS-3/STM-1 Telecom Bus (Channel 1) has been enabled - Transmit STS-3/STM-1 Telecom Bus Interface - Payload Indicator Signal - Channel 1:</p> <p>If STS-3/STM-1 Telecom Bus (Channel 1) is disabled - RLOL_1 (General Purpose) Input Pin:</p>

STS-3/STM-1 TELECOM BUS INTERFACE - TRANSMIT DIRECTION

PIN #	SIGNAL NAME	I/O	SIGNAL TYPE	DESCRIPTION
AD25	STS3TxA_PL_2 TxSBFrame_2 RLOL_2	I	TTL	<p>Transmit STS-3/STM-1 Telecom Bus Interface - Payload Indicator Signal - Channel 2/RLOL_2 (General Purpose) input Pin: See definition of Pin # E15 above replacing Channel 0 with Channel 2.</p> <p>If STS-3/STM-1 Telecom Bus (Channel 2) has been enabled - Transmit STS-3/STM-1 Telecom Bus Interface - Payload Indicator Signal - Channel 2:</p> <p>If STS-3/STM-1 Telecom Bus (Channel 2) is disabled - RLOL_2 (General Purpose) Input Pin:</p>
AB17	STS3TxA_PL_3 TxSBFrame_3 RLOL_3	I	TTL	<p>Transmit STS-3/STM-1 Telecom Bus Interface - Payload Indicator Signal - Channel 3/RLOL_3 (General Purpose) input Pin: See definition of Pin # E15 above replacing Channel 0 with Channel 3.</p> <p>If STS-3/STM-1 Telecom Bus (Channel 3) has been enabled - Transmit STS-3/STM-1 Telecom Bus Interface - Payload Indicator Signal - Channel 3:</p> <p>If STS-3/STM-1 Telecom Bus (Channel 3) is disabled - RLOL_3 (General Purpose) Input Pin:</p>

STS-3/STM-1 TELECOM BUS INTERFACE - TRANSMIT DIRECTION

PIN #	SIGNAL NAME	I/O	SIGNAL TYPE	DESCRIPTION
B24	STS3TxA_C1J1_0 ING_LCV_IN_8 ING_RxNEG_IN_8 TxSTS1PL_8	I/O	TTL/ CMOS	<p>Transmit STS-3/STM-1 Telecom Bus Interface C1/J1 Byte Phase Indicator Input Signal (Channel 0); DS3/E3 Framer Block LCV/RxNEG Input Pin - Channel 8:</p> <p>The function of this pin depends upon whether or not the STS-3/STM-1 Telecom Bus Interface for Trlrcom Bus Channel 0 has been enabled.</p> <p>If STS-3/STM-1 Telecom Bus (Telecom Bus Channel 0) has been enabled - Transmit STS-3/STM-1 Telecom Bus Interface C1/J1 Byte Phase Indicator Input Signal (Channel 0):</p> <p>This input pin should be pulsed "high" during both of the following conditions.</p> <ol style="list-style-type: none"> 1. Whenever the C1 byte is being input to the STS-3/STM-1 Transmit Telecom Bus (TXA_D_0[7:0]) input pins. 2. Whenever the J1 byte is being input to the STS-3/STM-1 Transmit Telecom Bus (TXA_D_0[7:0]) input pins. <p>If STS-3/STM-1 Telecom Bus (Channel 0) is disabled - DS3/E3 Framer Block LCV/NEG Input - Channel 8:</p> <p>If the STS-3/STM-1 Telecom Bus (Channel 0) is disabled and if the DS3/E3 Framer block (associated with Channel 8) is enabled then this pin will function as either an LCV or an RxNEG input pin.</p> <p>If Channel 8 is configured to operate in the Single-Rail Mode, and if the Primary Frame Synchronizer block is configured to operate in the Ingress Path - ING_LCV_IN_8 Input pin:</p> <p>If the Primary Frame Synchronizer Block (associated with Channel 8) is configured to operate in the Ingress Path, and if Channel 8 is configured to operate in the Single-Rail Mode, then this input pin will function as the "LCV" (Line Code Violation) input pin. In this case, the user should connect this particular input pin to the "LCV" output pin of the corresponding DS3/E3/STS-1 LIU Channel.</p> <p>If Channel 8 is configured to operate in the Dual-Rail Mode, and if the Primary Frame Synchronizer block is configured to operate in the Ingress Path - ING_RxNEG_IN_8:</p> <p>If the Primary Frame Synchronizer block (associated with Channel 8) is configured to operate in the Ingress Path, and if Channel 8 is configured to operate in the Dual-Rail Mode, then this input pin will function as the "RxNEG" (Negative Polarity Data) input pin. In this case, the user should connect this particular input to the "RxNEG" output pin of the corresponding DS3/E3/STS-1 LIU Channel.</p> <p>NOTE: This pin is inactive if the Primary Frame Synchronizer block (associated with Channel 8) is NOT configured to operate in the Ingress Path.</p>

STS-3/STM-1 TELECOM BUS INTERFACE - TRANSMIT DIRECTION

PIN #	SIGNAL NAME	I/O	SIGNAL TYPE	DESCRIPTION
J23	<p>STS3TxA_C1J1_1</p> <p>ING_LCV_IN_9</p> <p>ING_RxNEG_IN_9</p> <p>TxSBFrame_1</p>	I/O	TTL/ CMOS	<p>Transmit STS-3/STM-1 Telecom Bus Interface - C1/J1 Byte Phase Indicator Input Signal (Channel 1); DS3/E3 Framer Block LCV/RxNEG Input Pin - Channel 9:</p> <p>The function of this pin depends upon whether or not the STS-3/STM-1 Telecom Bus Interface for Telecom Bus Channel 1 has been enabled.</p> <p>If STS-3/STM-1 Telecom Bus (Telecom Bus Channel 1) has been enabled - Transmit STS-3/STM-1 Telecom Bus Interface C1/J1 Byte Phase Indicator Input Signal (Channel 1):</p> <p>This input pin should be pulsed "High" during both of the following conditions.</p> <ol style="list-style-type: none"> 1. Whenever the C1 byte is being input to the STS-3/STM-1 Transmit Telecom Bus (TXA_D_1[7:0]) input pins. 2. Whenever the J1 byte is being input to the STS-3/STM-1 Transmit Telecom Bus (TXA_D_1[7:0]) input pins. <p>If STS-3/STM-1 Telecom Bus (Channel 1) is disabled - DS3/E3 Framer Block LCV/RxNEG Input - Channel 9:</p> <p>If the STS-3/STM-1 Telecom Bus (Channel 1) is disabled and if the DS3/E3 Framer block is enabled then this pin will function as either an LCV or RxNEG input pin.</p> <p>If Channel 9 is configured to operate in the Single-Rail Mode, and if the Primary Frame Synchronizer block is configured to operate in the Ingress Path - ING_LCV_IN_9 Input pin:</p> <p>If the Primary Frame Synchronizer Block (associated with Channel 9) is configured to operate in the Ingress Path, and if Channel 8 is configured to operate in the Single-Rail Mode, then this input pin will function as the "LCV" (Line Code Violation) input pin. In this case, the user should connect this particular input pin to the "LCV" output pin of the corresponding DS3/E3/STS-1 LIU Channel.</p> <p>If Channel 9 is configured to operate in the Dual-Rail Mode, and if the Primary Frame Synchronizer block is configured to operate in the Ingress Path - ING_RxNEG_IN_9:</p> <p>If the Primary Frame Synchronizer block (associated with Channel 9) is configured to operate in the Ingress Path, and if Channel 9 is configured to operate in the Dual-Rail Mode, then this input pin will function as the "RxNEG" (Negative Polarity Data) input pin. In this case, the user should connect this particular input to the "RxNEG" output pin of the corresponding DS3/E3/STS-1 LIU Channel.</p> <p>NOTE: This pin is inactive if the Primary Frame Synchronizer block (associated with Channel 9) is NOT configured to operate in the Ingress Path.</p>

STS-3/STM-1 TELECOM BUS INTERFACE - TRANSMIT DIRECTION

PIN #	SIGNAL NAME	I/O	SIGNAL TYPE	DESCRIPTION
AF24	STS3TxA_C1J1_2 ING_LCV_IN_10 ING_RxNEG_IN_10 TxSTS1PL_10 TxSBFrame_2	I/O	TTL/ CMOS	<p>Transmit STS-3/STM-1 Telecom Bus Interface - C1/J1 Byte Phase Indicator Input Signal (Channel 2); DS3/E3 Framer Block LCV/RxNEG Input pin - Channel 10:</p> <p>The function of this pin depends upon whether or not the STS-3/STM-1 Telecom Bus Interface for Channel 2 has been enabled.</p> <p>If STS-3/STM-1 Telecom Bus (Channel 2) has been enabled - STS-3/STM-1 Transmit Telecom Bus C1/J1 Byte Phase Indicator Input Signal (Channel 2):</p> <p>This input pin should be pulsed "High" during both of the following conditions.</p> <ol style="list-style-type: none"> 1. Whenever the C1 byte is being input to the STS-3/STM-1 Transmit Telecom Bus (TXA_D_2[7:0]) input pins. 2. Whenever the J1 byte is being input to the STS-3/STM-1 Transmit Telecom Bus (TXA_D_2[7:0]) input pins. <p>If STS-3/STM-1 Telecom Bus (Channel 2) is disabled - DS3/E3 Framer Block LCV/RxNEG Input - Channel 10):</p> <p>If the STS-3/STM-1 Telecom Bus (Channel 2) is disabled and if the DS3/E3 Framer block is enabled then this pin will function as either an LCV or an RxNEG input pin.</p> <p>If Channel 10 is configured to operate in the Single- Rail Mode, and if the Primary Frame Synchronizer block is configured to operate in the Ingress Path - ING_LCV_IN_10 Input pin:</p> <p>If the Primary Frame Synchronizer Block (associated with Channel 10) is configured to operate in the Ingress Path, and if Channel 10 is configured to operate in the Single-Rail Mode, then this input pin will function as the "LCV" (Line Code Violation) input pin. In this case, the user should connect this particular input pin to the "LCV" output pin of the corresponding DS3/E3/STS-1 LIU Channel.</p> <p>If Channel 10 is configured to operate in the Dual-Rail Mode, and if the Primary Frame Synchronizer block is configured to operate in the Ingress Path - ING_RxNEG_IN_10:</p> <p>If the Primary Frame Synchronizer block (associated with Channel 10) is configured to operate in the Ingress Path, and if Channel 10 is configured to operate in the Dual-Rail Mode, then this input pin will function as the "RxNEG" (Negative Polarity Data) input pin. In this case, the user should connect this particular input to the "RxNEG" output pin of the corresponding DS3/E3/STS-1 LIU Channel.</p> <p>NOTE: This pin is inactive if the Primary Frame Synchronizer block (associated with Channel 10) is NOT configured to operate in the Ingress Path.</p>

STS-3/STM-1 TELECOM BUS INTERFACE - TRANSMIT DIRECTION

PIN #	SIGNAL NAME	I/O	SIGNAL TYPE	DESCRIPTION
AF17	STS3TxA_C1J1_3 ING_LCV_IN_11 ING_RxNEG_IN_11 TxSTS1PL_11 TxSBFrame_3	I/O	TTL/ CMOS	<p>STS-3/STM-1 Transmit Telecom Bus C1/J1 Byte Phase Indicator Input Signal (Channel 3); DS3/E3 Frame Generator Framing Pulse Input/Output Pin - Channel 11:</p> <p>The function of this pin depends upon whether or not the STS-3/STM-1 Telecom Bus Interface for Telecom Bus Channel 3 has been enabled.</p> <p>If STS-3/STM-1 Telecom Bus (Telecom Bus Channel 3) has been enabled - STS-3/STM-1 Transmit Telecom Bus C1/J1 Byte Phase Indicator Input Signal (Channel 3):</p> <p>This input pin should be pulsed "High" during both of the following conditions.</p> <ol style="list-style-type: none"> 1. Whenever the C1 byte is being input to the STS-3/STM-1 Transmit Telecom Bus (TXA_D_3[7:0]) input pins. 2. Whenever the J1 byte is being input to the STS-3/STM-1 Transmit Telecom Bus (TXA_D_3[7:0]) input pins. <p>If STS-3/STM-1 Telecom Bus (Channel 3) is disabled - DS3/E3 Framer Block LCV/RxNEG Input - Channel 11)</p> <p>:If the STS-3/STM-1 Telecom Bus (Channel 3) is disabled and if the DS3/E3 Framer block (associated with Channel 11) is enabled then this pin will function as either an LCV or an RxNEG input pin.</p> <p>If Channel 11 is configured to operate in the Single- Rail Mode, and if the Primary Frame Synchronizer block is configured to operate in the Ingress Path - ING_LCV_IN_11 Input pin:</p> <p>If the Primary Frame Synchronizer Block (associated with Channel 11) is configured to operate in the Ingress Path, and if Channel 11 is configured to operate in the Single-Rail Mode, then this input pin will function as the "LCV" (Line Code Violation) input pin. In this case, the user should connect this particular input pin to the "LCV" output pin of the corresponding DS3/E3/STS-1 LIU Channel.</p> <p>If Channel 11 is configured to operate in the Dual-Rail Mode, and if the Primary Frame Synchronizer block is configured to operate in the Ingress Path - ING_RxNEG_IN_11:</p> <p>If the Primary Frame Synchronizer block (associated with Channel 11) is configured to operate in the Ingress Path, and if Channel 8 is configured to operate in the Dual-Rail Mode, then this input pin will function as the "RxNEG" (Negative Polarity Data) input pin. In this case, the user should connect this particular input to the "RxNEG" output pin of the corresponding DS3/E3/STS-1 LIU Channel.</p> <p>NOTE: This pin is inactive if the Primary Frame Synchronizer block (associated with Channel 11) is NOT configured to operate in the Ingress Path.</p>

STS-3/STM-1 TELECOM BUS INTERFACE - TRANSMIT DIRECTION

PIN #	SIGNAL NAME	I/O	SIGNAL TYPE	DESCRIPTION
B22	STS3TxA_DP_0 ING_LCV_IN_4 ING_RxNEG_IN_4 TxSTS1PL_4	I/O	TTL/ CMOS	<p>Transmit STS-3/STM-1 Telecom Bus - Parity Input Pin - Channel 0; DS3/E3 Framer Block LCV/RxNEG Input Pin - Channel 4:</p> <p>The function of this pin depends upon whether or not the STS-3/STM-1 Telecom Bus Interface for Telecom Bus Channel 0 has been enabled.</p> <p>If STS-3/STM-1 Telecom Bus Telecom Bus (Channel 0) has been enabled - Transmit STS-3/STM-1 Telecom Bus Interface - Parity Input Pin:</p> <p>This input pin can be configured to function as one of the following.</p> <ol style="list-style-type: none"> 1. The EVEN or ODD parity value of the bits which are input via the ST3TXA_D_0[7:0] input pins. 2. The EVEN or ODD parity value of the bits which are being input via the STS3TXA_D_0[7:0] input and the states of the STS3TXA_PL_0 and STS3TXA_C1J1_0 input pins. <p>NOTE: Any one of these configuration selections can be made by writing the appropriate value into the Interface Control Register - Byte 0 register (Indirect Address = 0x00, 0x3B), (Direct Address = 0x013B).</p> <p>If STS-3/STM-1 Telecom Bus (Telecom Bus Channel 0) is disabled - DS3/E3 Framer Block LCV/RxNEG Input - Channel 4):</p> <p>If the STS-3/STM-1 Telecom Bus (Channel 0) is disabled and if the DS3/E3 Framer block (associated with Channel 4) is enabled then this pin will function as either an LCV or an RxNEG input pin.</p> <p>If Channel 4 is configured to operate in the Single-Rail Mode, and if the Primary Frame Synchronizer block is configured to operate in the Ingress Path - ING_LCV_IN_4 Input pin:</p> <p>If the Primary Frame Synchronizer Block (associated with Channel 4) is configured to operate in the Ingress Path, and if Channel 4 is configured to operate in the Single-Rail Mode, then this input pin will function as the "LCV" (Line Code Violation) input pin. In this case, the user should connect this particular input pin to the "LCV" output pin of the corresponding DS3/E3/STS-1 LIU Channel.</p> <p>If Channel 8 is configured to operate in the Dual-Rail Mode, and if the Primary Frame Synchronizer block is configured to operate in the Ingress Path - ING_RxNEG_IN_4:</p> <p>If the Primary Frame Synchronizer block (associated with Channel 4) is configured to operate in the Ingress Path, and if Channel 4 is configured to operate in the Dual-Rail Mode, then this input pin will function as the "RxNEG" (Negative Polarity Data) input pin. In this case, the user should connect this particular input to the "RxNEG" output pin of the corresponding DS3/E3/STS-1 LIU Channel.</p> <p>NOTE: This pin is inactive if the Primary Frame Synchronizer block (associated with Channel 4) is NOT configured to operate in the Ingress Path.</p>

STS-3/STM-1 TELECOM BUS INTERFACE - TRANSMIT DIRECTION

PIN #	SIGNAL NAME	I/O	SIGNAL TYPE	DESCRIPTION
G23	STS3TxA_DP_1 ING_LCV_IN_5 ING_RxNEG_IN_5 TxSTS1PL_5	I/O	TTL/ CMOS	<p>Transmit STS-3/STM-1 Telecom Bus Interface - Parity Input Pin - Channel 1, DS3/E3 Framer Block LCV/RxNEG Input Pin - Channel 5:</p> <p>The function of this input pin depends upon whether or not the STS-3/STM-1 Telecom Bus Interface for Channel 1 has been enabled.</p> <p>If STS-3/STM-1 Telecom Bus (Transmit Channel 1) has been enabled - STS-3/STM-1 Transmit Telecom Bus - Parity Input Pin:</p> <p>This input pin can be configured to function as one of the following.</p> <ol style="list-style-type: none"> 1. The EVEN or ODD parity value of the bits which are input via the ST3TXA_D_1[7:0] input pins. 2. The EVEN or ODD parity value of the bits which are being input via the STS3TXA_D_1[7:0] input and the states of the STS3TXA_PL_1 and STS3TXA_C1J1_1 input pins. <p>NOTE: Any one of these configuration selections can be made by writing the appropriate value into the Interface Control Register - Byte 1 register (Indirect Address = 0x00, 0x3A), (Direct Address = 0x013A).</p> <p>If STS-3/STM-1 Telecom Bus (Channel 1) is disabled - DS3/E3 Framer Block LCV/RxNEG Input - Channel 5:</p> <p>If the STS-3/STM-1 Telecom Bus (Channel 1) is disabled and if the DS3/E3 Framer block (associated with Channel 5) is enabled then this pin will function as either an LCV or an RxNEG input pin.</p> <p>If Channel 5 is configured to operate in the Single-Rail Mode, and if the Primary Frame Synchronizer block is configured to operate in the Ingress Path - ING_LCV_IN_5 Input pin:</p> <p>If the Primary Frame Synchronizer Block (associated with Channel 5) is configured to operate in the Ingress Path, and if Channel 5 is configured to operate in the Single-Rail Mode, then this input pin will function as the "LCV" (Line Code Violation) input pin. In this case, the user should connect this particular input pin to the "LCV" output pin of the corresponding DS3/E3/STS-1 LIU Channel.</p> <p>If Channel 5 is configured to operate in the Dual-Rail Mode, and if the Primary Frame Synchronizer block is configured to operate in the Ingress Path - ING_RxNEG_IN_5:</p> <p>If the Primary Frame Synchronizer block (associated with Channel 5) is configured to operate in the Ingress Path, and if Channel 5 is configured to operate in the Dual-Rail Mode, then this input pin will function as the "RxNEG" (Negative Polarity Data) input pin. In this case, the user should connect this particular input to the "RxNEG" output pin of the corresponding DS3/E3/STS-1 LIU Channel.</p> <p>NOTE: This pin is inactive if the Primary Frame Synchronizer block (associated with Channel 5) is NOT configured to operate in the Ingress Path.</p>

STS-3/STM-1 TELECOM BUS INTERFACE - TRANSMIT DIRECTION

PIN #	SIGNAL NAME	I/O	SIGNAL TYPE	DESCRIPTION
AE24	STS3TxA_DP_2 ING_LCV_IN_6 ING_RxNEG_IN_6 TxSTS1PL_6	I/O	TTL/ CMOS	<p>Transmit STS-3/STM-1 Telecom Bus Interface - Parity Input Pin - Channel 2, DS3/E3 Framer Block LCV/RxNEG Input Pin - Channel 6:</p> <p>The function of this input pin depends upon whether or not the STS-3/STM-1 Telecom Bus Interface for Channel 2 has been enabled.</p> <p>If STS-3/STM-1 Telecom Bus (Channel 2) has been enabled - Transmit STS-3/STM-1 Telecom Bus Interface - Parity Input Pin:</p> <p>This input pin can be configured to function as one of the following.</p> <ol style="list-style-type: none"> 1. The EVEN or ODD parity value of the bits which are input via the ST3TXA_D_2[7:0] input pins. 2. The EVEN or ODD parity value of the bits which are being input via the STS3TXA_D_2[7:0] input and the states of the STS3TXA_PL_2 and STS3TXA_C1J1_2 input pins. <p>NOTE: Any one of these configuration selections can be made by writing the appropriate value into the Interface Control Register - Byte 2 register (Indirect Address = 0x00, 0x39), (Direct Address = 0x0139).</p> <p>If STS-3/STM-1 Telecom Bus (Channel 2) is disabled - DS3/E3 Framer Block LCV/RxNEG Input - Channel 6:</p> <p>If the STS-3/STM-1 Telecom Bus (Channel 2) is disabled and if the DS3/E3 Framer block (associated with Channel 6) is enabled then this pin will function as either an LCV or an RxNEG input pin.</p> <p>If Channel 6 is configured to operate in the Single-Rail Mode, and if the Primary Frame Synchronizer block is configured to operate in the Ingress Path - ING_LCV_IN_6 Input pin:</p> <p>If the Primary Frame Synchronizer Block (associated with Channel 6) is configured to operate in the Ingress Path, and if Channel 6 is configured to operate in the Single-Rail Mode, then this input pin will function as the "LCV" (Line Code Violation) input pin. In this case, the user should connect this particular input pin to the "LCV" output pin of the corresponding DS3/E3/STS-1 LIU Channel.</p> <p>If Channel 6 is configured to operate in the Dual-Rail Mode, and if the Primary Frame Synchronizer block is configured to operate in the Ingress Path - ING_RxNEG_IN_6:</p> <p>If the Primary Frame Synchronizer block (associated with Channel 6) is configured to operate in the Ingress Path, and if Channel 6 is configured to operate in the Dual-Rail Mode, then this input pin will function as the "RxNEG" (Negative Polarity Data) input pin. In this case, the user should connect this particular input to the "RxNEG" output pin of the corresponding DS3/E3/STS-1 LIU Channel.</p> <p>NOTE: This pin is inactive if the Primary Frame Synchronizer block (associated with Channel 6) is NOT configured to operate in the Ingress Path.</p>

STS-3/STM-1 TELECOM BUS INTERFACE - TRANSMIT DIRECTION

PIN #	SIGNAL NAME	I/O	SIGNAL TYPE	DESCRIPTION
AE19	STS3TxA_DP_3 ING_LCV_IN_7 ING_RxNEG_IN_7 TxSTS1PL_7	I/O	TTL/ CMOS	<p>Transmit STS-3/STM-1 Telecom Bus Interface - Parity Input Pin - Channel 3, DS3/E3 Framer Block LCV/RxNEG Input Pin - Channel - Channel 7:</p> <p>The function of this input pin depends upon whether or not the STS-3/STM-1 Telecom Bus Interface for Channel 3 has been enabled.</p> <p>If STS-3/STM-1 Telecom Bus (Channel 3) has been enabled - Transmit STS-3/STM-1 Telecom Bus Interface - Parity Input Pin:</p> <p>This input pin can be configured to function as one of the following.</p> <ol style="list-style-type: none"> 1. The EVEN or ODD parity value of the bits which are input via the ST3TXA_D_3[7:0] input pins. 2. The EVEN or ODD parity value of the bits which are being input via the STS3TXA_D_3[7:0] input and the states of the STS3TXA_PL_3 and STS3TXA_C1J1_3 input pins. <p>NOTE: Any one of these configuration selections can be made by writing the appropriate value into the Interface Control Register - Byte 3 register (Indirect Address = 0x00, 0x38), (Direct Address = 0x0138).</p> <p>If STS-3/STM-1 Telecom Bus (Channel 0) is disabled - DS3/E3 Framer Block LCV/RxNEG Input Pin - Channel 7:</p> <p>If the STS-3/STM-1 Telecom Bus (Channel 3) is disabled and if the DS3/E3 Framer block (associated with Channel 7) is enabled then this pin will function as either an LCV or an RxNEG input pin.</p> <p>If Channel 7 is configured to operate in the Single-Rail Mode, and if the Primary Frame Synchronizer block is configured to operate in the Ingress Path - ING_LCV_IN_7 Input pin:</p> <p>If the Primary Frame Synchronizer block (associated with Channel 7) is configured to operate in the Ingress Path, and if Channel 7 is configured to operate in the Single-Rail Mode, then this input pin will function as the "LCV" (Line Code Violation) input pin. In this case, the user should connect this particular input pin to the "LCV" output pin of the corresponding DS3/E3/STS-1 LIU Channel.</p> <p>If Channel 7 is configured to operate in the Dual-Rail Mode, and if the Primary Frame Synchronizer block is configured to operate in the Ingress Path - ING_RxNEG_IN_7:</p> <p>If the Primary Frame Synchronizer block (associated with Channel 7) is configured to operate in the Ingress Path, and if Channel 7 is configured to operate in the Dual-Rail Mode, then this input pin will function as the "RxNEG" (Negative Polarity Data) input pin. In this case, the user should connect this particular input to the "RxNEG" output pin of the corresponding DS3/E3/STS-1 LIU Channel.</p> <p>NOTE: This pin is inactive if the Primary Frame Synchronizer block (associated with Channel 7) is NOT configured to operate in the Ingress Path.</p>

STS-3/STM-1 TELECOM BUS INTERFACE - TRANSMIT DIRECTION

PIN #	SIGNAL NAME	I/O	SIGNAL TYPE	DESCRIPTION
B18	STS3TxA_ALARM_0 ING_LCV_IN_0 ING_RxNEG_IN_0 TxSTS1PL_0	I/O	TTL/ CMOS	<p>Transmit STS-3/STM-1 Telecom Bus - Alarm Indicator Input - Channel 0; DS3/E3 Framer Block LCV/RxNEG Input Pin - Channel 0:</p> <p>The function of this input pin depends upon whether or not the STS-3/STM-1 Telecom Bus Interface for Channel 0 has been enabled.</p> <p>If STS-3/STM-1 Telecom Bus (Channel 0) has been enabled - Transmit STS-3/STM-1 Telecom Bus Interface - Alarm Indicator Input:</p> <p>This input pin pulses "High" coincident to any STS-1 signal (which is carrying the AIS-P indicator) being applied to the STS3TxA_D_0[7:0] input data bus.</p> <p><i>NOTE: If the STS3TXA_ALARM_0 input signal pulses "High" for any given STS-1 signal (within the incoming STS-3), then the XRT94L43 will automatically declare an AIS-P for that STS-1 channel.</i></p> <p>If STS-3/STM-1 Telecom Bus (Channel 0) is disabled - DS3/E3 Framer Block LCV/RxNEG Input Pin - Channel 0:</p> <p>If the STS-3/STM-1 Telecom Bus (Channel 0) is disabled and if the DS3/E3 Framer block (associated with Channel 0) is enabled then this pin will function as either an LCV or an RxNEG input pin.</p> <p>If Channel 0 is configured to operate in the Single-Rail Mode, and if the Primary Frame Synchronizer block is configured to operate in the Ingress Path - ING_LCV_IN_0 Input pin</p> <p>If the Primary Frame Synchronizer block (associated with Channel 0) is configured to operate in the Ingress Path, and if Channel 0 is configured to operate in the Single-Rail Mode, then this input pin will function as the "LCV" (Line Code Violation) input pin. In this case, the user should connect this particular input pin to the "LCV" output pin of the corresponding DS3/E3/STS-1 LIU Channel.</p> <p>If Channel 7 is configured to operate in the Dual-Rail Mode, and if the Primary Frame Synchronizer block is configured to operate in the Ingress Path - ING_RxNEG_IN_0:</p> <p>If the Primary Frame Synchronizer block (associated with Channel 0) is configured to operate in the Ingress Path and if Channel 0 is configured to operate in the Dual-Rail Mode, then this input pin will function as the "RxNEG" (Negative Polarity Data) input pin. In this case, the user should connect this particular input to the "RxNEG" output pin of the corresponding DS3/E3/STS-1 LIU Channel</p> <p><i>NOTE: This pin is inactive if the Primary Frame Synchronizer block (associated with Channel 0) is NOT configured to operate in the Ingress Path.</i></p>

STS-3/STM-1 TELECOM BUS INTERFACE - TRANSMIT DIRECTION

PIN #	SIGNAL NAME	I/O	SIGNAL TYPE	DESCRIPTION
D25	STS3TxA_ALARM_1 ING_LCV_IN_1 ING_RxNEG_IN_1 TxSTS1PL_1	I/O	TTL/ CMOS	<p>Transmit STS-3/STM-1 Telecom Bus - Alarm Indicator Input - Channel 1; DS3/E3 Framer Block LCV/RxNEG Input Pin - Channel 1:</p> <p>The function of this input pin depends upon whether or not the STS-3/STM-1 Telecom Bus Interface for Channel 1 has been enabled.</p> <p>If STS-3/STM-1 Telecom Bus (Channel 1) has been enabled - Transmit STS-3/STM-1 Telecom Bus Interface - Alarm Indicator Input:</p> <p>This input pin pulses "High" coincident to any STS-1 signal (which is carrying the AIS-P indicator) being applied to the STS3TxA_D_1[7:0] input data bus.</p> <p>NOTE: <i>If the STS3TxA_ALARM_1 input signal pulses "High" for any given STS-1 signal (within the incoming STS-3), then the XRT94L43 will automatically declare an AIS-P for that STS-1 channel.</i></p> <p>If STS-3/STM-1 Telecom Bus (Channel 1) is disabled - DS3/E3 Framer Block LCV/RxNEG Input Pin - Channel 1):</p> <p>If the STS-3/STM-1 Telecom Bus (Channel 1) is disabled and if the DS3/E3 Framer block (associated with channel 1) is enabled then this pin will function as either an LCV or an RxNEG input pin.</p> <p>If Channel 1 is configured to operate in the Single-Rail Mode, and if the Primary Frame Synchronizer block is configured to operate in the Ingress Path - ING_LCV_IN_1 Input Pin:</p> <p>If the Primary Frame Synchronizer block (associated with Channel 1) is configured to operate in the Ingress Path, and if Channel 1 is configured to operate in the Single-Rail Mode, then this input pin will function as the "LCV" (Line Code Violation) input pin. In this case, the user should connect this particular input pin to the "LCV" output pin of the corresponding DS3/E3/STS-1 LIU Channel.</p> <p>If Channel 1 is configured to operate in the Dual-Rail Mode, and if the Primary Frame Synchronizer block is configured to operate in the Ingress Path - ING_RxNEG_IN_1:</p> <p>If the Primary Frame Synchronizer block (associated with Channel 1) is configured to operate in the Ingress Path and if Channel 1 is configured to operate in the Dual-Rail Mode, then this input pin will function as the "RxNEG" (Negative Polarity Data) input pin. In this case, the user should connect this particular input to the "RxNEG" output pin of the corresponding DS3/E3/STS-1 LIU Channel.</p> <p>NOTE: <i>This pin is inactive if the Primary Frame Synchronizer block (associated with Channel 1) is NOT configured to operate in the Ingress Path</i></p>

STS-3/STM-1 TELECOM BUS INTERFACE - TRANSMIT DIRECTION

PIN #	SIGNAL NAME	I/O	SIGNAL TYPE	DESCRIPTION
AB26	STS3TxA_ALARM_2 ING_LCV_IN_2 ING_RxNEG_IN_2 TxSTS1PL_2	I/O	TTL/ CMOS	<p>Transmit STS-3/STM-1 Telecom Bus - Alarm Indicator Input - Channel 2; DS3/E3 Framer Block LCV/RxNEG Input Pin - Channel 2:</p> <p>The function of this input pin depends upon whether or not the STS-3/STM-1 Telecom Bus Interface for Channel 2 has been enabled.</p> <p>If STS-3/STM-1 Telecom Bus (Channel 2) has been enabled - Transmit STS-3/STM-1 Telecom Bus Interface - Alarm Indicator Input:</p> <p>This input pin pulses "High" coincident to any STS-1 signal (which is carrying the AIS-P indicator) being applied to the STS3TxA_D_2[7:0] input data bus.</p> <p>NOTE: <i>If the STS3TxA_ALARM_2 input signal pulses "High" for any given STS-1 signal (within the incoming STS-3), then the XRT94L43 will automatically declare an AIS-P for that STS-1 channel.</i></p> <p>If STS-3/STM-1 Telecom Bus (Channel 2) is disabled - DS3/E3 Framer Block LCV/RxNEG Input Pin - Channel 2:</p> <p>If the STS-3/STM-1 Telecom Bus (Channel 2) is disabled and if the DS3/E3 Framer block (associated with channel 2) is enabled then this pin will function as either an LCV or an RxNEG input pin.</p> <p>If Channel 2 is configured to operate in the Single-Rail Mode, and if the Primary Frame Synchronizer block is configured to operate in the Ingress Path - ING_LCV_IN_2 Input pin:</p> <p>If the Primary Frame Synchronizer block (associated with Channel 2) is configured to operate in the Ingress Path, and if Channel 2 is configured to operate in the Single-Rail Mode, then this input pin will function as the "LCV" (Line Code Violation) input pin. In this case, the user should connect this particular input pin to the "LCV" output pin of the corresponding DS3/E3/STS-1 LIU Channel.</p> <p>If Channel 2 is configured to operate in the Dual-Rail Mode, and if the Primary Frame Synchronizer block is configured to operate in the Ingress Path - ING_RxNEG_IN_2:</p> <p>If the Primary Frame Synchronizer block (associated with Channel 2) is configured to operate in the Ingress Path and if Channel 2 is configured to operate in the Dual-Rail Mode, then this input pin will function as the "RxNEG" (Negative Polarity Data) input pin. In this case, the user should connect this particular input to the "RxNEG" output pin of the corresponding DS3/E3/STS-1 LIU Channel.</p> <p>NOTE: <i>This pin is inactive if the Primary Frame Synchronizer block (associated with Channel 2) is NOT configured to operate in the Ingress Path.</i></p>

STS-3/STM-1 TELECOM BUS INTERFACE - TRANSMIT DIRECTION

PIN #	SIGNAL NAME	I/O	SIGNAL TYPE	DESCRIPTION
AF22	STS3TxA_ALARM_3 ING_LCV_IN_3 ING_RxNEG_IN_3 TxSTS1PL_3	I/O	TTL/ CMOS	<p>Transmit STS-3/STM-1 Telecom Bus - Alarm Indicator Input - Channel 3; DS3/E3 Framer Block LCV/RxNEG Input Pin - Channel 3:</p> <p>The function of this input pin depends upon whether or not the STS-3/STM-1 Telecom Bus Interface for Channel 3 has been enabled.</p> <p>If STS-3/STM-1 Telecom Bus (Channel 3) has been enabled - Transmit STS-3/STM-1 Telecom Bus Interface - Alarm Indicator Input:</p> <p>This input pin pulses "High" coincident to any STS-1 signal (which is carrying the AIS-P indicator) being applied to the STS3TxA_D_3[7:0] input data bus.</p> <p><i>NOTE: If the STS3TxA_ALARM_3 input signal pulses "High" for any given STS-1 signal (within the incoming STS-3), then the XRT94L43 will automatically declare an AIS-P for that STS-1 channel.</i></p> <p>If STS-3/STM-1 Telecom Bus (Channel 3) is disabled - DS3/E3 Framer Block LCV/RxNEG Input Pin - Channel 3):</p> <p>If the STS-3/STM-1 Telecom Bus (Channel 3) is disabled and if the DS3/E3 Framer block (associated with channel 3) is enabled then this pin will function as either an LCV or an RxNEG input pin.</p> <p>If Channel 3 is configured to operate in the Single-Rail Mode, and if the Primary Frame Synchronizer block is configured to operate in the Ingress Path - ING_LCV_IN_3 Input pin:</p> <p>If the Primary Frame Synchronizer block (associated with Channel 3) is configured to operate in the Ingress Path, and if Channel 3 is configured to operate in the Single-Rail Mode, then this input pin will function as the "LCV" (Line Code Violation) input pin. In this case, the user should connect this particular input pin to the "LCV" output pin of the corresponding DS3/E3/STS-1 LIU Channel.</p> <p>If Channel 3 is configured to operate in the Dual-Rail Mode, and if the Primary Frame Synchronizer block is configured to operate in the Ingress Path - ING_RxNEG_IN_3:</p> <p>If the Primary Frame Synchronizer block (associated with Channel 3) is configured to operate in the Ingress Path and if Channel 3 is configured to operate in the Dual-Rail Mode, then this input pin will function as the "RxNEG" (Negative Polarity Data) input pin. In this case, the user should connect this particular input to the "RxNEG" output pin of the corresponding DS3/E3/STS-1 LIU Channel.</p> <p><i>NOTE: This pin is inactive if the Frame Generator block, associated with Channel 3 is by-passed</i></p>

STS-3/STM-1 TELECOM BUS INTERFACE - TRANSMIT DIRECTION

PIN #	SIGNAL NAME	I/O	SIGNAL TYPE	DESCRIPTION
C15	STS3TxA_D_0_0 TxSBDATA_0 RLOOP_0	I/O	TTL/ CMOS	<p>Transmit STS-3/STM-1 Telecom Bus - Channel 0 - Input Data Bus Pin Number 0/RLOOP_0 (General Purpose) output pin:</p> <p>The function of this pin depends upon whether or not the STS-3/STM-1 Telecom Bus Interface, associated with Channel 0 is enabled.</p> <p>If STS-3/STM-1 Telecom Bus (Channel 0) has been enabled - Transmit STS-3/STM-1 Telecom Bus Interface - Input Data Bus Pin Number 0:</p> <p>This input pin along with STS3TxA_D_0[7:1] function as the STS-3/STM-1 Transmit (Add) Telecom Bus - Input Data Bus for Channel 0. This input pin functions as the LSB (Least Significant Bit) input pin on the Transmit (Add) Telecom Bus - Input Data Bus. The STS-3/STM-1 Telecom Bus interface will sample and latch this pin upon the falling edge of STS3TxA_CLK_0.</p> <p>The LSB of any byte, which is being input into the STS-3/STM-1 Transmit Telecom Bus - Data Bus (for Channel 0) should be input via this pin.</p> <p>If STS-3/STM-1 Telecom Bus (Channel 0) is disabled - RLOOP_0 (General Purpose) output Pin:</p> <p>This output pin can be used as a general purpose output pin.</p> <p>The state of this output pin can be controlled by writing the appropriate value into Bit 1 (RLOOP) within the Line Interface Drive Register associated with Channel 0 (Indirect Address = 0x1E, 0x80), (Direct Address = 0x1F80).</p> <p>NOTE: For Product Legacy purposes, this pin is called RLOOP_0 because one possible application is to tie this output pin to an RLOOP (Remote Loop-back) input pin from one of Exar's XRT73L0X/XRT75L0X DS3/E3/STS-1 LIU devices. However, this output pin, and the corresponding register bit can be used for any purpose.</p>

STS-3/STM-1 TELECOM BUS INTERFACE - TRANSMIT DIRECTION

PIN #	SIGNAL NAME	I/O	SIGNAL TYPE	DESCRIPTION
C16	STS3TxA_D_0_1 TxSBDATA_1 REQ_0	I/O	TTL/ CMOS	<p>Transmit STS-3/STM-1 Telecom Bus - Channel 0 - Input Data Bus Pin Number 0/REQ_0 (General Purpose) output Pin:</p> <p>The function of this pin depends upon whether or not the STS-3/STM-1 Telecom Bus Interface, associated with Channel 0 is enabled.</p> <p>If STS-3/STM-1 Telecom Bus (Channel 0) has been enabled - STS-3/STM-1 Transmit Telecom Bus - Input Data Bus Pin Number 1:</p> <p>This input pin along with STS3TxA_D_0[7:2] and STS3TxA_D_0_0 function as the STS-3/STM-1 Transmit (Add) Telecom Bus - Input Data Bus for Channel 0. The STS-3/STM-1 Telecom Bus interface will sample and latch this pin upon the falling edge of STS3TxA_CLK_0.</p> <p>If STS-3/STM-1 Telecom Bus (Channel 0) is disabled - REQ_0 (General Purpose) output pin.</p> <p>This output pin can be used as a general purpose output pin.</p> <p>The state of this output pin can be controlled by writing the appropriate value into Bit 5 (REQB) within the Line Interface Drive Register associated with Channel 0 (Indirect Address = 0x1E, 0x80), (Direct Address = 0x1F01).</p> <p>NOTE: For Product Legacy purposes, this pin is called REQ_0 because one possible application is to tie this output pin to an REQB (Receive Equalizer By-Pass) or REQEN (Receive Equalizer Enable) input pin from one of Exar's XRT73L0X/ XRT75L0X DS3/E3/STS-1 LIU devices. However, this output pin, and the corresponding register bit can be used for any purpose.</p>

STS-3/STM-1 TELECOM BUS INTERFACE - TRANSMIT DIRECTION

PIN #	SIGNAL NAME	I/O	SIGNAL TYPE	DESCRIPTION
B19	STS3TxA_D_0_2 TxSBDATA_2 DS3/E3/ STS1_DATA_IN_0	I	TTL	<p>Transmit STS-3/STM-1 Telecom Bus - Channel 0 - Input Data Bus Pin Number 2/DS3/E3 Framer or Receive STS-1 TOH Processor block line interface input Pin - Channel 0:</p> <p>The function of this pin depends upon whether or not the STS-3/STM-1 Telecom Bus Interface, associated with Channel 0 is enabled.</p> <p>If STS-3/STM-1 Telecom Bus (Channel 0) has been enabled - STS-3/STM-1 Transmit Telecom Bus - Input Data Bus Pin Number 2:</p> <p>STS3TxA_D_0_2 This input pin along with STS3TxA_D_0[7:3] and STS3TxA_D_0[1:0] function as the STS-3/STM-1 Transmit (Add) Telecom Bus - Input Data Bus for Channel 0. The STS-3/STM-1 Telecom Bus interface will sample and latch this pin upon the falling edge of STS3TxA_CLK_0.</p> <p>If STS-3/STM-1 Telecom Bus (Channel 0) is disabled - DS3/E3/STS1_DATA_IN - DS3/E3/STS-1 Line Interface Data Input - Channel 0:</p> <p>This input accepts single-rail, recovered DS3, E3 or STS-1 data (from a DS3/E3/STS-1 LIU IC). This input pin should be connected to the RPOS output of the DS3/E3/STS-1 LIU IC (corresponding to channel 0).</p> <p>By default, the data that is applied to this input pin will be latched into the XRT94L43 upon the falling edge of the DS3/E3/STS1_CLK_IN_0 signal pin number F15.</p> <p>For DS3/E3 Applications</p> <p>The XRT94L43 can be configured to latch this input signal upon the rising edge of the DS3/E3/STS1_CLK_IN_0 signal by setting Bit 1 (DS3/E3/STS1_CLK_IN Invert), within the I/O Control Register - Channel 0 (Indirect Address = 0x1E, 0x01), (Direct Address = 0x1F01) to a "1".</p> <p>For STS-1 Applications</p> <p>The XRT94L43 can not be configured to sample the DS3/E3/STS1_DATA_IN_0 signal upon the rising edge of DS3/E3/STS1_CLK_IN_0.</p>

STS-3/STM-1 TELECOM BUS INTERFACE - TRANSMIT DIRECTION

PIN #	SIGNAL NAME	I/O	SIGNAL TYPE	DESCRIPTION
B23	STS3TxA_D_0_3 TxSBDATA_3 DS3/E3/ STS1_DATA_IN_4	I	TTL	<p>Transmit STS-3/STM-1 Telecom Bus - Channel 0 - Input Data Bus Pin Number 3/DS3/E3 Framer or Receive STS-1 TOH Processor block line interface input Pin - Channel 4:</p> <p>The function of this pin depends upon whether or not the STS-3/STM-1 Telecom Bus Interface, associated with Channel 0 is enabled.</p> <p>If STS-3/STM-1 Telecom Bus (Channel 0) has been enabled - STS-3/STM-1 Transmit Telecom Bus - Input Data Bus Pin Number 2: STS3TxA_D_0_3:</p> <p>This input pin along with STS3TxA_D_0[7:4] and STS3TxA_D_0[2:0] function as the STS-3/STM-1 Transmit (Add) Telecom Bus - Input Data Bus for Channel 0. The STS-3/STM-1 Telecom Bus interface will sample and latch this pin upon the falling edge of STS3TxA_CLK_0.</p> <p>If STS-3/STM-1 Telecom Bus (Channel 0) is disabled - DS3/E3/STS1_DATA_IN - DS3/E3/STS-1 Line Interface Data Input - Channel 4:</p> <p>This input accepts single-rail, recovered DS3, E3 or STS-1 data (from a DS3/E3/STS-1 LIU IC). This input pin should be connected to the RPOS output of the DS3/E3/STS-1 LIU IC (corresponding to channel 4).</p> <p>By default, the data that is applied to this input pin will be latched into the XRT94L43 upon the falling edge of the DS3/E3/STS1_CLK_IN_4 signal pin number A22.</p> <p>For DS3/E3 Applications</p> <p>The XRT94L43 can be configured to latch this input signal upon the rising edge of the DS3/E3/STS1_CLK_IN_4 signal by setting Bit 1 (DS3/E3/STS1_CLK_IN Invert), within the I/O Control Register - Channel 4 (Indirect Address = 0x5E, 0x01), (Direct Address = 0x5F01) to a "1".</p> <p>For STS-1 Applications</p> <p>The XRT94L43 can not be configured to sample the DS3/E3/STS1_DATA_IN_4 signal upon the rising edge of DS3/E3/STS1_CLK_IN_4.</p>

STS-3/STM-1 TELECOM BUS INTERFACE - TRANSMIT DIRECTION

PIN #	SIGNAL NAME	I/O	SIGNAL TYPE	DESCRIPTION
B25	STS3TxA_D_0_4 TxSBDATA_4 DS3/E3/ STS1_DATA_IN_8	I	TTL	<p>Transmit STS-3/STM-1 Telecom Bus - Channel 0 - Input Data Bus Pin Number 3/DS3/E3 Framer or Receive STS-1 TOH Processor block line interface input Pin - Channel 4:</p> <p>The function of this pin depends upon whether or not the STS-3/STM-1 Telecom Bus Interface, associated with Channel 0 is enabled.</p> <p>If STS-3/STM-1 Telecom Bus (Channel 0) has been enabled - STS-3/STM-1 Transmit Telecom Bus - Input Data Bus Pin Number 4: STS3TxA_D_0_4:</p> <p>This input pin along with STS3TxA_D_0[7:5] and STS3TxA_D_0[3:0] function as the STS-3/STM-1 Transmit (Add) Telecom Bus - Input Data Bus for Channel 0. The STS-3/STM-1 Telecom Bus interface will sample and latch this pin upon the falling edge of STS3TxA_CLK_0.</p> <p>If STS-3/STM-1 Telecom Bus (Channel 0) is disabled - DS3/E3/STS1_DATA_IN - DS3/E3/STS-1 Line Interface Data Input - Channel 8:</p> <p>This input accepts single-rail, recovered DS3, E3 or STS-1 data (from a DS3/E3/STS-1 LIU IC). This input pin should be connected to the RPOS output of the DS3/E3/STS-1 LIU IC (corresponding to channel 8).</p> <p>By default, the data that is applied to this input pin will be latched into the XRT94L43 upon the falling edge of the DS3/E3/STS1_CLK_IN_8 signal pin number A24.</p> <p>For DS3/E3 Applications</p> <p>The XRT94L43 can be configured to latch this input signal upon the rising edge of the DS3/E3/STS1_CLK_IN_8 signal by setting Bit 1 (DS3/E3/STS1_CLK_IN Invert), within the I/O Control Register - Channel 8 (Indirect Address = 0x9E, 0x01), (Direct Address = 0x9F01) to a "1".</p> <p>For STS-1 Applications:</p> <p>The XRT94L43 can not be configured to sample the DS3/E3/STS1_DATA_IN_8 signal upon the rising edge of Ds3/E3/STS1_CLK_IN_8.</p>

STS-3/STM-1 TELECOM BUS INTERFACE - TRANSMIT DIRECTION

PIN #	SIGNAL NAME	I/O	SIGNAL TYPE	DESCRIPTION
F15	STS3TxA_D_0_5 TxSBDATA_5 DS3/E3/ STS1_CLK_IN_0	I	TTL	<p>Transmit STS-3/STM-1 Telecom Bus - Channel 0 - Input Data Bus Pin Number 5/DS3/E3 Framer or Receive STS-1 TOH Processor block line interface clock input Pin - Channel 0:</p> <p>The function of this pin depends upon whether or not the STS-3/STM-1 Telecom Bus Interface, associated with Channel 0 is enabled.</p> <p>If STS-3/STM-1 Telecom Bus (Channel 0) has been enabled - STS-3/STM-1 Transmit Telecom Bus - Input Data Bus Pin Number 5: STS3TxA_D_0_5:</p> <p>This input pin along with STS3TxA_D_0[7:6] and STS3TxA_D_0[4:0] function as the STS-3/STM-1 Transmit (Add) Telecom Bus - Input Data Bus for Channel 0. The STS-3/STM-1 Telecom Bus interface will sample and latch this pin upon the falling edge of STS3TxA_CLK_0.</p> <p>If STS-3/STM-1 Telecom Bus (Channel 0) is disabled - DS3/E3/STS1_CLK_IN - DS3/E3/STS-1 Line Interface Clock Input - Channel 0:</p> <p>This input accepts a recovered DS3, E3 or STS-1 clock signal (from a DS3/E3/STS-1 LIU IC). This input pin should be connected to the RCLK output of the DS3/E3/STS-1 LIU IC (corresponding to channel 0).</p> <p>The XRT94L43 uses this clock signal to sample and latch the data that is applied to the DS3/E3/STS1_DATA_IN_0 input pin number B19.</p> <p>By default, the data that is applied to the DS3/E3/STS1_DATA_IN_0 input pin will be latched into the XRT94L43 upon the falling edge of this clock signal.</p> <p>For DS3/E3 Applications</p> <p>The XRT94L43 can be configured to latch the DS3/E3/STS1_DATA_IN_0 signal upon the rising edge of this clock signal by setting Bit 1 (DS3/E3/STS1_CLK_IN Invert), within the I/O Control Register - Channel 0 (Indirect Address = 0x1E, 0x01)," (Direct Address = 0x1F01) to a "1".</p> <p>For STS-1 Applications</p> <p>The XRT94L43 can not be configured to sample the DS3/E3/STS1_DATA_IN_0 signal upon the rising edge of this clock signal.</p>

STS-3/STM-1 TELECOM BUS INTERFACE - TRANSMIT DIRECTION

PIN #	SIGNAL NAME	I/O	SIGNAL TYPE	DESCRIPTION
A22	STS3TxA_D_0_6 TxSBDATA_6 DS3/E3/ STS1_CLK_IN_4	I	TTL	<p>Transmit STS-3/STM-1 Telecom Bus - Channel 0 - Input Data Bus Pin Number 6/DS3/E3 Framer or Receive STS-1 TOH Processor block line interface clock input Pin - Channel 4:</p> <p>The function of this pin depends upon whether or not the STS-3/STM-1 Telecom Bus Interface, associated with Channel 0 is enabled.</p> <p>If STS-3/STM-1 Telecom Bus (Channel 0) has been enabled - STS-3/STM-1 Transmit Telecom Bus - Input Data Bus Pin Number 6: STS3TxA_D_0_6:</p> <p>This input pin along with STS3TxA_D_0_7 and STS3TxA_D_0[5:0] function as the STS-3/STM-1 Transmit (Add) Telecom Bus - Input Data Bus for Channel 0. The STS-3/STM-1 Telecom Bus interface will sample and latch this pin upon the falling edge of STS3TxA_CLK_0.</p> <p>If STS-3/STM-1 Telecom Bus (Channel 0) is disabled - DS3/E3/STS1_CLK_IN - DS3/E3/STS-1 Line Interface Clock Input - Channel 4:</p> <p>This input accepts a recovered DS3, E3 or STS-1 clock signal (from a DS3/E3/STS-1 LIU IC). This input pin should be connected to the RCLK output of the DS3/E3/STS-1 LIU IC (corresponding to channel 4).</p> <p>The XRT94L43 uses this clock signal to sample and latch the data that is applied to the DS3/E3/STS1_DATA_IN_4 input pin number B23.</p> <p>By default, the data that is applied to the DS3/E3/STS1_DATA_IN_4 input pin will be latched into the XRT94L43 upon the falling edge of this clock signal.</p> <p>For DS3/E3 Applications</p> <p>The XRT94L43 can be configured to latch the DS3/E3/STS1_DATA_IN_4 signal upon the rising edge of this clock signal by setting Bit 1 (DS3/E3/STS1_CLK_IN Invert), within the I/O Control Register - Channel 4 (Indirect Address = 0x5E, 0x01), (Direct Address = 0x5F01) to a "1".</p> <p>For STS-1 Applications</p> <p>The XRT94L43 can not be configured to sample the DS3/E3/STS1_DATA_IN_4 signal upon the rising edge of this clock signal.</p>

STS-3/STM-1 TELECOM BUS INTERFACE - TRANSMIT DIRECTION

PIN #	SIGNAL NAME	I/O	SIGNAL TYPE	DESCRIPTION
A24	STS3TxA_D_0_7 TxSB_DATA_7 DS3/E3/ STS1_CLK_IN_8	I	TTL	<p>Transmit STS-3/STM-1 Telecom Bus - Channel 0 - Input Data Bus Pin Number 7/DS3/E3 Framer or Receive STS-1 TOH Processor block line interface clock input Pin - Channel 8:</p> <p>The function of this pin depends upon whether or not the STS-3/STM-1 Telecom Bus Interface, associated with STS-3/STM-1 Channel 0 is enabled.</p> <p>If STS-3/STM-1 Telecom Bus (STS-3/STM-1 - Channel 0) has been enabled - STS-3/STM-1 Transmit Telecom Bus - Input Data Bus Pin Number 7: STS3TxA_D_0_7:</p> <p>This input pin along with STS3TxA_D_0[6:0] function as the STS-3/STM-1 Transmit (Add) Telecom Bus - Input Data Bus for Channel 0. The STS-3/STM-1 Telecom Bus interface will sample and latch this pin upon the falling edge of STS3TxA_CLK_0.</p> <p><i>NOTE: This input pin functions as the MSB (Most Significant Bit) of the Transmit (Add) Telecom Bus, for Channel 0.</i></p> <p>If STS-3/STM-1 Telecom Bus (STS-3/STM-1 - Channel 0) is disabled - DS3/E3/STS1_CLK_IN - DS3/E3/STS-1 Line Interface Clock Input - Channel 8:</p> <p>This input accepts a recovered DS3, E3 or STS-1 clock signal (from a DS3/E3/STS-1 LIU IC). This input pin should be connected to the RCLK output of the DS3/E3/STS-1 LIU IC (corresponding to channel 8).</p> <p>The XRT94L43 uses this clock signal to sample and latch the data that is applied to the DS3/E3/STS1_DATA_IN_8 input pin number B25.</p> <p>By default, the data that is applied to the DS3/E3/STS1_DATA_IN_8 input pin will be latched into the XRT94L43 upon the falling edge of this clock signal.</p> <p>For DS3/E3 Applications</p> <p>The XRT94L43 can be configured to latch the DS3/E3/STS1_DATA_IN_8 signal upon the rising edge of this clock signal by setting Bit 1 (DS3/E3/STS1_CLK_IN Invert), within the I/O Control Register - Channel 8 (Indirect Address = 0x9E, 0x01), " (Direct Address = 0x9F01) to a "1".</p> <p>For STS-1 Applications</p> <p>The XRT94L43 can not be configured to sample the DS3/E3/STS1_DATA_IN_8 signal upon the rising edge of this clock signal.</p>

STS-3/STM-1 TELECOM BUS INTERFACE - TRANSMIT DIRECTION

PIN #	SIGNAL NAME	I/O	SIGNAL TYPE	DESCRIPTION
C25	STS3TxA_D_1_0 TxSBDATA_0 RLOOP_1	I/O	TTL	<p>Transmit STS-3/STM-1 Telecom Bus - Channel 1 - Input Data Bus Pin Number 0/RLOOP_1 (General Purpose) output Pin:</p> <p>The function of this pin depends upon whether or not the STS-3/STM-1 Telecom Bus Interface, associated with Channel 1 is enabled.</p> <p>If STS-3/STM-1 Telecom Bus (Channel 1) has been enabled - STS-3/STM-1 Transmit Telecom Bus - Input Data Bus Pin Number 0:</p> <p>This input pin along with STS3TxA_D_1[7:1] function as the STS-3/STM-1 Transmit (Add) Telecom Bus - Input Data Bus for Channel 1. This input pin functions as the LSB (Least Significant Bit) input pin on the Transmit (Add) Telecom Bus - Input Data Bus. The STS-3/STM-1 Telecom Bus interface will sample and latch this pin upon the falling edge of STS3TxA_CLK_1.</p> <p>The LSB of any byte, which is being input into the STS-3/STM-1 Transmit Telecom Bus - Data Bus (for Channel 1) should be input via this pin.</p> <p>If STS-3/STM-1 Telecom Bus (Channel 1) is disabled - RLOOP_1 (General Purpose) output Pin:</p> <p>This output pin can be used as a general purpose output pin.</p> <p>The state of this output pin can be controlled by writing the appropriate value into Bit 1 (RLOOP) within the Line Interface Drive Register associated with Channel 1 (Indirect Address = 0x2E, 0x80), (Direct Address = 0x2F80).</p> <p>NOTE: For Product Legacy purposes, this pin is called RLOOP_1 because one possible application is to tie this output pin to an RLOOP (Remote Loop-back) input pin from one of Exar's XRT73L0X/XRT75L0X DS3/E3/STS-1 LIU devices. However, this output pin, and the corresponding register bit can be used for any purpose.</p>

STS-3/STM-1 TELECOM BUS INTERFACE - TRANSMIT DIRECTION

PIN #	SIGNAL NAME	I/O	SIGNAL TYPE	DESCRIPTION
B26	STS3TxA_D_1_1 TxSBDATA_1 REQ_1	I/O	TTL	<p>Transmit STS-3/STM-1 Telecom Bus - Channel 1 - Input Data Bus Pin Number 1/REQ_1 (General Purpose) output Pin:</p> <p>The function of this pin depends upon whether or not the STS-3/STM-1 Telecom Bus Interface, associated with Channel 1 is enabled.</p> <p>If STS-3/STM-1 Telecom Bus (Channel 1) has been enabled - STS-3/STM-1 Transmit Telecom Bus - Input Data Bus Pin Number 1:</p> <p>This input pin along with STS3TxA_D_1[7:2] and STS3TxA_D_1_0 function as the STS-3/STM-1 Transmit (Add) Telecom Bus - Input Data Bus for Channel 1. The STS-3/STM-1 Telecom Bus interface will sample and latch this pin upon the falling edge of STS3TxA_CLK_1.</p> <p>If STS-3/STM-1 Telecom Bus (Channel 1) is disabled - REQ_1 (General Purpose) output Pin:</p> <p>This output pin can be used as a general purpose output pin. The state of this output pin can be controlled by writing the appropriate value into Bit 5 (REQB) within the Line Interface Drive Register associated with Channel 1 (Indirect Address = 0x2E, 0x80), (Direct Address = 0x2F80).</p> <p>NOTE: For Product Legacy purposes, this pin is called REQ_1 because one possible application is to tie this output pin to an REQB (Receive Equalizer By-Pass) or REQEN (Receive Equalizer Enable) input pin from one of Exar's XRT73L0X/ XRT75L0X DS3/E3/STS-1 LIU devices. However, this output pin, and the corresponding register bit can be used for any purpose.</p>

STS-3/STM-1 TELECOM BUS INTERFACE - TRANSMIT DIRECTION

PIN #	SIGNAL NAME	I/O	SIGNAL TYPE	DESCRIPTION
E26	STS3TxA_D_1_2 TxSBDATA_2 DS3/E3/ STS1_DATA_IN_1	I	TTL	<p>Transmit STS-3/STM-1 Telecom Bus - Channel 1 - Input Data Bus Pin Number 2/DS3/E3 Framer or Receive STS-1 TOH Processor block line interface input Pin - Channel 1:</p> <p>The function of this pin depends upon whether or not the STS-3/STM-1 Telecom Bus Interface, associated with Channel 1 is enabled.</p> <p>If STS-3/STM-1 Telecom Bus (Channel 1) has been enabled - STS-3/STM-1 Transmit Telecom Bus - Input Data Bus Pin Number 2: STS3TxA_D_1_2:</p> <p>This input pin along with STS3TxA_D_1[7:3] and STS3TxA_D_1[1:0] function as the STS-3/STM-1 Transmit (Add) Telecom Bus - Input Data Bus for Channel 1. The STS-3/STM-1 Telecom Bus interface will sample and latch this pin upon the falling edge of STS3TxA_CLK_1.</p> <p>If STS-3/STM-1 Telecom Bus (Channel 1) is disabled - DS3/E3/STS1_DATA_IN - DS3/E3/STS-1 Line Interface Data Input - Channel 1:</p> <p>This input accepts single-rail, recovered DS3, E3 or STS-1 data (from a DS3/E3/STS-1 LIU IC). This input pin should be connected to the RPOS output of the DS3/E3/STS-1 LIU IC (corresponding to channel 1).</p> <p>By default, the data that is applied to this input pin will be latched into the XRT94L43 upon the falling edge of the DS3/E3/STS1_CLK_IN_1 signal pin number D26.</p> <p>For DS3/E3 Applications</p> <p>The XRT94L43 can be configured to latch this input signal upon the rising edge of the DS3/E3/STS1_CLK_IN_1 signal by setting Bit 1 (DS3/E3/STS1_CLK_IN Invert), within the I/O Control Register - Channel 1 (Indirect Address = 0x2E, 0x01), (Direct Address = 0x2F01) to a "1".</p> <p>For STS-1 Applications</p> <p>The XRT94L43 can not be configured to sample the DS3/E3/STS1_DATA_IN_1 signal upon the rising edge of DS3/E3/STS1_CLK_IN_1.</p>

STS-3/STM-1 TELECOM BUS INTERFACE - TRANSMIT DIRECTION

PIN #	SIGNAL NAME	I/O	SIGNAL TYPE	DESCRIPTION
G24	STS3TxA_D_1_3 TxSBDATA_3 DS3/E3/ STS1DATA_IN_5	I	TTL	<p>Transmit STS-3/STM-1 Telecom Bus - Channel 1 - Input Data Bus Pin Number 3/DS3/E3 Framer or Receive STS-1 TOH Processor block line interface input Pin - Channel 5:</p> <p>The function of this pin depends upon whether or not the STS-3/STM-1 Telecom Bus Interface, associated with Channel 1 is enabled.</p> <p>If STS-3/STM-1 Telecom Bus (Channel 1) has been enabled - STS-3/STM-1 Transmit Telecom Bus - Input Data Bus Pin Number 3: STS3TxA_D_1_3:</p> <p>This input pin along with STS3TxA_D_1[7:4] and STS3TxA_D_1[2:0] function as the STS-3/STM-1 Transmit (Add) Telecom Bus - Input Data Bus for Channel 1. The STS-3/STM-1 Telecom Bus interface will sample and latch this pin upon the falling edge of STS3TxA_CLK_1.</p> <p>If STS-3/STM-1 Telecom Bus (Channel 1) is disabled - DS3/E3/STS1_DATA_IN - DS3/E3/STS-1 Line Interface Data Input - Channel 5:</p> <p>This input accepts single-rail, recovered DS3, E3 or STS-1 data (from a DS3/E3/STS-1 LIU IC). This input pin should be connected to the RPOS output of the DS3/E3/STS-1 LIU IC (corresponding to channel 5).</p> <p>By default, the data that is applied to this input pin will be latched into the XRT94L43 upon the falling edge of the DS3/E3/STS1_CLK_IN_5 signal pin number F23.</p> <p>For DS3/E3 Applications</p> <p>The XRT94L43 can be configured to latch this input signal upon the rising edge of the DS3/E3/STS1_CLK_IN_5 signal by setting Bit 1 (DS3/E3/STS1_CLK_IN Invert), within the I/O Control Register - Channel 5 (Indirect Address = 0x6E, 0x01), (Direct Address = 0x6F01) to a "1".</p> <p>For STS-1 Applications</p> <p>The XRT94L43 can not be configured to sample the DS3/E3/STS1_DATA_IN_5 signal upon the rising edge of DS3/E3/STS1_CLK_IN_5.</p>

STS-3/STM-1 TELECOM BUS INTERFACE - TRANSMIT DIRECTION

PIN #	SIGNAL NAME	I/O	SIGNAL TYPE	DESCRIPTION
J24	STS3TxA_D_1_4 TxSBDATA_4 DS3/E3/ STS1_DATA_IN_9	I	TTL	<p>Transmit STS-3/STM-1 Telecom Bus - Channel 1 - Input Data Bus Pin Number 4/DS3/E3 Framer or Receive STS-1 TOH Processor block line interface input Pin - Channel 9:</p> <p>The function of this pin depends upon whether or not the STS-3/STM-1 Telecom Bus Interface, associated with Channel 1 is enabled.</p> <p>If STS-3/STM-1 Telecom Bus (Channel 1) has been enabled - STS-3/STM-1 Transmit Telecom Bus - Input Data Bus Pin Number 4: STS3TxA_D_1_4:</p> <p>This input pin along with STS3TxA_D_1[7:5] and STS3TxA_D_1[3:0] function as the STS-3/STM-1 Transmit (Add) Telecom Bus - Input Data Bus for Channel 1. The STS-3/STM-1 Telecom Bus interface will sample and latch this pin upon the falling edge of STS3TxA_CLK_1.</p> <p>If STS-3/STM-1 Telecom Bus (Channel 1) is disabled - DS3/E3/STS1_DATA_IN - DS3/E3/STS-1 Line Interface Data Input - Channel 9:</p> <p>This input accepts single-rail, recovered DS3, E3 or STS-1 data (from a DS3/E3/STS-1 LIU IC). This input pin should be connected to the RPOS output of the DS3/E3/STS-1 LIU IC (corresponding to channel 9).</p> <p>By default, the data that is applied to this input pin will be latched into the XRT94L43 upon the falling edge of the DS3/E3/STS1_CLK_IN_9 signal pin number H23.</p> <p>For DS3/E3 Applications</p> <p>The XRT94L43 can be configured to latch this input signal upon the rising edge of the DS3/E3/STS1_CLK_IN_9 signal by setting Bit 1 (DS3/E3/STS1_CLK_IN Invert), within the I/O Control Register - Channel 9 (Indirect Address = 0xAE, 0x01), (Direct Address = 0xAF01) to a "1".</p> <p>For STS-1 Applications</p> <p>The XRT94L43 can not be configured to sample the DS3/E3/STS1_DATA_IN_9 signal upon the rising edge of DS3/E3/STS1_CLK_IN_9.</p>

STS-3/STM-1 TELECOM BUS INTERFACE - TRANSMIT DIRECTION

PIN #	SIGNAL NAME	I/O	SIGNAL TYPE	DESCRIPTION
D26	STS3TxA_D_1_5 DS3/E3/ STS1_Clk_IN_1 TxSBData_5	I	TTL	<p>Transmit STS-3/STM-1 Telecom Bus - Channel 1 - Input Data Bus Pin Number 5/DS3/E3 Framer or Receive STS-1 TOH Processor block line interface clock input Pin - Channel 1:</p> <p>The function of this pin depends upon whether or not the STS-3/STM-1 Telecom Bus Interface, associated with Channel 1 is enabled.</p> <p>If STS-3/STM-1 Telecom Bus (Channel 1) has been enabled - STS-3/STM-1 Transmit Telecom Bus - Input Data Bus Pin Number 5: STS3TxA_D_1_5:</p> <p>This input pin along with STS3TxA_D_1[7:6] and STS3TxA_D_1[4:0] function as the STS-3/STM-1 Transmit (Add) Telecom Bus - Input Data Bus for Channel 1. The STS-3/STM-1 Telecom Bus interface will sample and latch this pin upon the falling edge of STS3TxA_CLK_1.</p> <p>If STS-3/STM-1 Telecom Bus (Channel 1) is disabled - DS3/E3/STS1_CLK_IN - DS3/E3/STS-1 Line Interface Clock Input - Channel 1:</p> <p>This input accepts a recovered DS3, E3 or STS-1 clock signal (from a DS3/E3/STS-1 LIU IC). This input pin should be connected to the RCLK output of the DS3/E3/STS-1 LIU IC (corresponding to channel 1). The XRT94L43 uses this clock signal to sample and latch the data that is applied to the DS3/E3/STS1_DATA_IN_1 input pin number E26.</p> <p>By default, the data that is applied to the DS3/E3/STS1_DATA_IN_1 input pin will be latched into the XRT94L43 upon the falling edge of this clock signal.</p> <p>For DS3/E3 Applications</p> <p>The XRT94L43 can be configured to latch the DS3/E3/STS1_DATA_IN_1 signal upon the rising edge of this clock signal by setting Bit 1 (DS3/E3/STS1_CLK_IN Invert), within the I/O Control Register - Channel 1 (Indirect Address = 0x2E, 0x01), (Direct Address = 0x2F01) to a "1".</p> <p>For STS-1 Applications</p> <p>The XRT94L43 can not be configured to sample the DS3/E3/STS1_DATA_IN_1 signal upon the rising edge of this clock signal.</p>

STS-3/STM-1 TELECOM BUS INTERFACE - TRANSMIT DIRECTION

PIN #	SIGNAL NAME	I/O	SIGNAL TYPE	DESCRIPTION
F23	STS3TxA_D_1_6 DS3/E3/ STS1_CLK_IN_5 TxSBDData_6	I	TTL	<p>Transmit STS-3/STM-1 Telecom Bus - Channel 1 - Input Data Bus Pin Number 6/DS3/E3 Framer or Receive STS-1 TOH Processor block line interface clock input Pin - Channel 5:</p> <p>The function of this pin depends upon whether or not the STS-3/STM-1 Telecom Bus Interface, associated with Channel 1 is enabled.</p> <p>If STS-3/STM-1 Telecom Bus (Channel 1) has been enabled - STS-3/STM-1 Transmit Telecom Bus - Input Data Bus Pin Number 6: STS3TxA_D_1_6:</p> <p>This input pin along with STS3TxA_D_1_7 and STS3TxA_D_1[5:0] function as the STS-3/STM-1 Transmit (Add) Telecom Bus - Input Data Bus for Channel 1. The STS-3/STM-1 Telecom Bus interface will sample and latch this pin upon the falling edge of STS3TxA_CLK_1.</p> <p>If STS-3/STM-1 Telecom Bus (Channel 1) is disabled - DS3/E3/STS1_CLK_IN - DS3/E3/STS-1 Line Interface Clock Input - Channel 5:</p> <p>This input accepts a recovered DS3, E3 or STS-1 clock signal (from a DS3/E3/STS-1 LIU IC). This input pin should be connected to the RCLK output of the DS3/E3/STS-1 LIU IC (corresponding to channel 5). The XRT94L43 uses this clock signal to sample and latch the data that is applied to the DS3/E3/STS1_DATA_IN_5 input pin number G24.</p> <p>By default, the data that is applied to the DS3/E3/STS1_DATA_IN_5 input pin will be latched into the XRT94L43 upon the falling edge of this clock signal.</p> <p>For DS3/E3 Applications</p> <p>The XRT94L43 can be configured to latch the DS3/E3/STS1_DATA_IN_5 signal upon the rising edge of this clock signal by setting Bit 1 (DS3/E3/STS1_CLK_IN Invert), within the I/O Control Register - Channel 5 (Indirect Address = 0x6E, 0x01), (Direct Address = 0x6F01) to a "1".</p> <p>For STS-1 Applications</p> <p>The XRT94L43 can not be configured to sample the DS3/E3/STS1_DATA_IN_5 signal upon the rising edge of this clock signal.</p>

STS-3/STM-1 TELECOM BUS INTERFACE - TRANSMIT DIRECTION

PIN #	SIGNAL NAME	I/O	SIGNAL TYPE	DESCRIPTION
H23	STS3TxA_D_1_7 DS3/E3/ STS1_CLK_IN_9 TxSBData_7	I	TTL	<p>Transmit STS-3/STM-1 Telecom Bus - Channel 1 - Input Data Bus Pin Number 7/DS3/E3 Framer or Receive STS-1 TOH Processor block line interface clock input Pin - Channel 9:</p> <p>The function of this pin depends upon whether or not the STS-3/STM-1 Telecom Bus Interface, associated with Channel 1 is enabled.</p> <p>If STS-3/STM-1 Telecom Bus (Channel 1) has been enabled - STS-3/STM-1 Transmit Telecom Bus - Input Data Bus Pin Number 7: STS3TxA_D_1_7:</p> <p>This input pin along with STS3TxA_D_1[6:0] function as the STS-3/STM-1 Transmit (Add) Telecom Bus - Input Data Bus for Channel 1. The STS-3/STM-1 Telecom Bus interface will sample and latch this pin upon the falling edge of STS3TxA_CLK_1.</p> <p><i>NOTE: This input pin functions as the MSB (Most Significant Bit) of the Transmit (Add) Telecom Bus, for Channel 1.</i></p> <p>If STS-3/STM-1 Telecom Bus (Channel 1) is disabled - DS3/E3/STS1_CLK_IN - DS3/E3/STS-1 Line Interface Clock Input - Channel 9:</p> <p>This input accepts a recovered DS3, E3 or STS-1 clock signal (from a DS3/E3/STS-1 LIU IC). This input pin should be connected to the RCLK output of the DS3/E3/STS-1 LIU IC (corresponding to channel 9). The XRT94L43 uses this clock signal to sample and latch the data that is applied to the DS3/E3/STS1_DATA_IN_9 input pin number J24.</p> <p>By default, the data that is applied to the DS3/E3/STS1_DATA_IN_9 input pin will be latched into the XRT94L43 upon the falling edge of this clock signal.</p> <p>For DS3/E3 Applications</p> <p>The XRT94L43 can be configured to latch the DS3/E3/STS1_DATA_IN_9 signal upon the rising edge of this clock signal by setting Bit 1 (DS3/E3/STS1_CLK_IN Invert), within the I/O Control Register - Channel 9 (Indirect Address = 0xAE, 0x01), " (Direct Address = 0xAF01) to a "1".</p> <p>For STS-1 Applications</p> <p>The XRT94L43 can not be configured to sample the DS3/E3/STS1_DATA_IN_9 signal upon the rising edge of this clock signal.</p>

STS-3/STM-1 TELECOM BUS INTERFACE - TRANSMIT DIRECTION

PIN #	SIGNAL NAME	I/O	SIGNAL TYPE	DESCRIPTION
AD26	STS3TxA_D_2_0 RLOOP_2 TxSBData_0	I/O	TTL	<p>Transmit STS-3/STM-1 Telecom Bus - Channel 2 - Input Data Bus Pin Number 0/RLOOP_2 (General Purpose) output Pin:</p> <p>The function of this pin depends upon whether or not the STS-3/STM-1 Telecom Bus Interface, associated with Channel 2 is enabled.</p> <p>If STS-3/STM-1 Telecom Bus (Channel 2) has been enabled - STS-3/STM-1 Transmit Telecom Bus - Input Data Bus Pin Number 0:</p> <p>This input pin along with STS3TxA_D_2[7:1] function as the STS-3/STM-1 Transmit (Add) Telecom Bus - Input Data Bus for Channel 2. This input pin functions as the LSB (Least Significant Bit) input pin on the Transmit (Add) Telecom Bus - Input Data Bus. The STS-3/STM-1 Telecom Bus interface will sample and latch this pin upon the falling edge of STS3TxA_CLK_2.</p> <p>The LSB of any byte, which is being input into the STS-3/STM-1 Transmit Telecom Bus - Data Bus (for Channel 2) should be input via this pin.</p> <p>If STS-3/STM-1 Telecom Bus (Channel 2) is disabled - RLOOP_2 (General Purpose) output Pin:</p> <p>This output pin can be used as a general purpose output pin.</p> <p>The state of this output pin can be controlled by writing the appropriate value into Bit 1 (RLOOP) within the Line Interface Drive Register associated with Channel 2 (Indirect Address = 0x3E, 0x80), (Direct Address = 0x3F80).</p> <p>NOTE: For Product Legacy purposes, this pin is called RLOOP_2 because one possible application is to tie this output pin to an RLOOP (Remote Loop-back) input pin from one of Exar's XRT73L0X/XRT75L0X DS3/E3/STS-1 LIU devices. However, this output pin, and the corresponding register bit can be used for any purpose.</p>

STS-3/STM-1 TELECOM BUS INTERFACE - TRANSMIT DIRECTION

PIN #	SIGNAL NAME	I/O	SIGNAL TYPE	DESCRIPTION
AE26	STS3TxA_D_2_1 REQ_2 TxSBData_1	I/O	TTL	<p>Transmit STS-3/STM-1 Telecom Bus - Channel 2 - Input Data Bus Pin Number 1/REQ_2 (General Purpose) output Pin:</p> <p>The function of this pin depends upon whether or not the STS-3/STM-1 Telecom Bus Interface, associated with Channel 1 is enabled.</p> <p>If STS-3/STM-1 Telecom Bus (Channel 2) has been enabled - STS-3/STM-1 Transmit Telecom Bus - Input Data Bus Pin Number 1:</p> <p>This input pin along with STS3TxA_D_2[7:2] and STS3TxA_D_2_0 function as the STS-3/STM-1 Transmit (Add) Telecom Bus - Input Data Bus for Channel 2. The STS-3/STM-1 Telecom Bus interface will sample and latch this pin upon the falling edge of STS3TxA_CLK_2.</p> <p>If STS-3/STM-1 Telecom Bus (Channel 2) is disabled - REQ_2 (General Purpose) output Pin:</p> <p>This output pin can be used as a general purpose output pin. The state of this output pin can be controlled by writing the appropriate value into Bit 5 (REQB) within the Line Interface Drive Register associated with Channel 2 (Indirect Address = 0x3E, 0x80), (Direct Address = 0x3F80).</p> <p>NOTE: For Product Legacy purposes, this pin is called REQ_2 because one possible application is to tie this output pin to an REQB (Receive Equalizer By-Pass) or REQEN (Receive Equalizer Enable) input pin from one of Exar's XRT73L0X/ XRT75L0X DS3/E3/STS-1 LIU devices. However, this output pin, and the corresponding register bit can be used for any purpose.</p>

STS-3/STM-1 TELECOM BUS INTERFACE - TRANSMIT DIRECTION

PIN #	SIGNAL NAME	I/O	SIGNAL TYPE	DESCRIPTION
V24	STS3TxA_D_2_2 DS3/E3/ STS1_Data_IN_2 TxSBDData_2	I	TTL	<p>Transmit STS-3/STM-1 Telecom Bus - Channel 2 - Input Data Bus Pin Number 2/DS3/E3 Framer or Receive STS-1 TOH Processor block line interface input Pin - Channel 2:</p> <p>The function of this pin depends upon whether or not the STS-3/STM-1 Telecom Bus Interface, associated with Channel 2 is enabled.</p> <p>If STS-3/STM-1 Telecom Bus (Channel 2) has been enabled - STS-3/STM-1 Transmit Telecom Bus - Input Data Bus Pin Number 2: STS3TxA_D_2_2:</p> <p>This input pin along with STS3TxA_D_2[7:3] and STS3TxA_D_2[1:0] function as the STS-3/STM-1 Transmit (Add) Telecom Bus - Input Data Bus for Channel 2. The STS-3/STM-1 Telecom Bus interface will sample and latch this pin upon the falling edge of STS3TxA_CLK_2.</p> <p>If STS-3/STM-1 Telecom Bus (Channel 2) is disabled - DS3/E3/STS1_DATA_IN - DS3/E3/STS-1 Line Interface Data Input - Channel 2:</p> <p>This input accepts single-rail, recovered DS3, E3 or STS-1 data (from a DS3/E3/STS-1 LIU IC). This input pin should be connected to the RPOS output of the DS3/E3/STS-1 LIU IC (corresponding to channel 2).</p> <p>By default, the data that is applied to this input pin will be latched into the XRT94L43 upon the falling edge of the DS3/E3/STS1_CLK_IN_2 signal pin number V25.</p> <p>For DS3/E3 Applications</p> <p>The XRT94L43 can be configured to latch this input signal upon the rising edge of the DS3/E3/STS1_CLK_IN_2 signal by setting Bit 1 (DS3/E3/STS1_CLK_IN Invert), within the I/O Control Register - Channel 2 (Indirect Address = 0x3E, 0x01), (Direct Address = 0x3F01) to a "1".</p> <p>For STS-1 Applications</p> <p>The XRT94L43 can not be configured to sample the DS3/E3/STS1_DATA_IN_2 signal upon the rising edge of DS3/E3/STS1_CLK_IN_2.</p>

STS-3/STM-1 TELECOM BUS INTERFACE - TRANSMIT DIRECTION

PIN #	SIGNAL NAME	I/O	SIGNAL TYPE	DESCRIPTION
AD24	STS3TxA_D_2_3 DS3/E3/ STS1_Data_IN_6 TxSBData_3	I	TTL	<p>Transmit STS-3/STM-1 Telecom Bus - Channel 2 - Input Data Bus Pin Number 3/DS3/E3 Framer or Receive STS-1 TOH Processor block line interface input Pin - Channel 6:</p> <p>The function of this pin depends upon whether or not the STS-3/STM-1 Telecom Bus Interface, associated with Channel 2 is enabled.</p> <p>If STS-3/STM-1 Telecom Bus (Channel 2) has been enabled - STS-3/STM-1 Transmit Telecom Bus - Input Data Bus Pin Number 3: STS3TxA_D_2_3:</p> <p>This input pin along with STS3TxA_D_2[7:4] and STS3TxA_D_2[2:0] function as the STS-3/STM-1 Transmit (Add) Telecom Bus - Input Data Bus for Channel 2. The STS-3/STM-1 Telecom Bus interface will sample and latch this pin upon the falling edge of STS3TxA_CLK_2.</p> <p>If STS-3/STM-1 Telecom Bus (Channel 2) is disabled - DS3/E3/STS1_DATA_IN - DS3/E3/STS-1 Line Interface Data Input - Channel 6:</p> <p>This input accepts single-rail, recovered DS3, E3 or STS-1 data (from a DS3/E3/STS-1 LIU IC). This input pin should be connected to the RPOS output of the DS3/E3/STS-1 LIU IC (corresponding to channel 6).</p> <p>By default, the data that is applied to this input pin will be latched into the XRT94L43 upon the falling edge of the DS3/E3/STS1_CLK_IN_6 signal pin number Y22.</p> <p>For DS3/E3 Applications</p> <p>The XRT94L43 can be configured to latch this input signal upon the rising edge of the DS3/E3/STS1_CLK_IN_6 signal by setting Bit 1 (DS3/E3/STS1_CLK_IN Invert), within the I/O Control Register - Channel 6 (Indirect Address = 0x7E, 0x01), (Direct Address = 0x7F01) to a "1".</p> <p>For STS-1 Applications</p> <p>The XRT94L43 can not be configured to sample the DS3/E3/STS1_DATA_IN_6 signal upon the rising edge of DS3/E3/STS1_CLK_IN_6.</p>

STS-3/STM-1 TELECOM BUS INTERFACE - TRANSMIT DIRECTION

PIN #	SIGNAL NAME	I/O	SIGNAL TYPE	DESCRIPTION
AF25	STS3TxA_D_2_4 DS3/E3/ STS1_Data_IN_10 TxSBData_4	I	TTL	<p>Transmit STS-3/STM-1 Telecom Bus - Channel 2 - Input Data Bus Pin Number 4/DS3/E3 Framer or Receive STS-1 TOH Processor block line interface input Pin - Channel 10:</p> <p>The function of this pin depends upon whether or not the STS-3/STM-1 Telecom Bus Interface, associated with Channel 2 is enabled.</p> <p>If STS-3/STM-1 Telecom Bus (Channel 2) has been enabled - STS-3/STM-1 Transmit Telecom Bus - Input Data Bus Pin Number 4: STS3TxA_D_2_4:</p> <p>This input pin along with STS3TxA_D_2[7:5] and STS3TxA_D_2[3:0] function as the STS-3/STM-1 Transmit (Add) Telecom Bus - Input Data Bus for Channel 2. The STS-3/STM-1 Telecom Bus interface will sample and latch this pin upon the falling edge of STS3TxA_CLK_2.</p> <p>If STS-3/STM-1 Telecom Bus (Channel 2) is disabled - DS3/E3/STS1_DATA_IN - DS3/E3/STS-1 Line Interface Data Input - Channel 10:</p> <p>This input accepts single-rail, recovered DS3, E3 or STS-1 data (from a DS3/E3/STS-1 LIU IC). This input pin should be connected to the RPOS output of the DS3/E3/STS-1 LIU IC (corresponding to channel 10).</p> <p>By default, the data that is applied to this input pin will be latched into the XRT94L43 upon the falling edge of the DS3/E3/STS1_CLK_IN_10 signal pin number AB22.</p> <p>For DS3/E3 Applications</p> <p>The XRT94L43 can be configured to latch this input signal upon the rising edge of the DS3/E3/STS1_CLK_IN_10 signal by setting Bit 1 (DS3/E3/STS1_CLK_IN Invert), within the I/O Control Register - Channel 10 (Indirect Address = 0xBE, 0x01), (Direct Address = 0xBF01) to a "1".</p> <p>For STS-1 Applications</p> <p>The XRT94L43 can not be configured to sample the DS3/E3/STS1_DATA_IN_10 signal upon the rising edge of DS3/E3/STS1_CLK_IN_10.</p>

STS-3/STM-1 TELECOM BUS INTERFACE - TRANSMIT DIRECTION

PIN #	SIGNAL NAME	I/O	SIGNAL TYPE	DESCRIPTION
V25	STS3TxA_D_2_5 DS3/E3/ STS1_CLK_IN_2 TxSBData_5	I	TTL	<p>Transmit STS-3/STM-1 Telecom Bus - Channel 2 - Input Data Bus Pin Number 5/DS3/E3 Framer or Receive STS-1 TOH Processor block line interface clock input Pin - Channel 2:</p> <p>The function of this pin depends upon whether or not the STS-3/STM-1 Telecom Bus Interface, associated with Channel 2 is enabled.</p> <p>If STS-3/STM-1 Telecom Bus (Channel 2) has been enabled - STS-3/STM-1 Transmit Telecom Bus - Input Data Bus Pin Number 5: STS3TxA_D_2_5:</p> <p>This input pin along with STS3TxA_D_2[7:6] and STS3TxA_D_2[4:0] function as the STS-3/STM-1 Transmit (Add) Telecom Bus - Input Data Bus for Channel 2. The STS-3/STM-1 Telecom Bus interface will sample and latch this pin upon the falling edge of STS3TxA_CLK_2.</p> <p>If STS-3/STM-1 Telecom Bus (Channel 2) is disabled - DS3/E3/STS1_CLK_IN - DS3/E3/STS-1 Line Interface Clock Input - Channel 2:</p> <p>This input accepts a recovered DS3, E3 or STS-1 clock signal (from a DS3/E3/STS-1 LIU IC). This input pin should be connected to the RCLK output of the DS3/E3/STS-1 LIU IC (corresponding to channel 2). The XRT94L43 uses this clock signal to sample and latch the data that is applied to the DS3/E3/STS1_DATA_IN_2 input pin number V24.</p> <p>By default, the data that is applied to the DS3/E3/STS1_DATA_IN_2 input pin will be latched into the XRT94L43 upon the falling edge of this clock signal.</p> <p>For DS3/E3 Applications</p> <p>The XRT94L43 can be configured to latch the DS3/E3/STS1_DATA_IN_2 signal upon the rising edge of this clock signal by setting Bit 1 (DS3/E3/STS1_CLK_IN Invert), within the I/O Control Register - Channel 2 (Indirect Address = 0x3E, 0x01), (Direct Address = 0x3F01) to a "1".</p> <p>For STS-1 Applications</p> <p>The XRT94L43 can not be configured to sample the DS3/E3/STS1_DATA_IN_2 signal upon the rising edge of this clock signal.</p>

STS-3/STM-1 TELECOM BUS INTERFACE - TRANSMIT DIRECTION

PIN #	SIGNAL NAME	I/O	SIGNAL TYPE	DESCRIPTION
Y22	STS3TxA_D_2_6 DS3/E3/ STS1_CLK_IN_6 TxSBDData_6	I	TTL	<p>Transmit STS-3/STM-1 Telecom Bus - Channel 2 - Input Data Bus Pin Number 6/DS3/E3 Framer or Receive STS-1 TOH Processor block line interface clock input Pin - Channel 6:</p> <p>The function of this pin depends upon whether or not the STS-3/STM-1 Telecom Bus Interface, associated with Channel 2 is enabled.</p> <p>If STS-3/STM-1 Telecom Bus (Channel 2) has been enabled - STS-3/STM-1 Transmit Telecom Bus - Input Data Bus Pin Number 6: STS3TxA_D_2_6:</p> <p>This input pin along with STS3TxA_D_2_7 and STS3TxA_D_2[5:0] function as the STS-3/STM-1 Transmit (Add) Telecom Bus - Input Data Bus for Channel 2. The STS-3/STM-1 Telecom Bus interface will sample and latch this pin upon the falling edge of STS3TxA_CLK_2.</p> <p>If STS-3/STM-1 Telecom Bus (Channel 2) is disabled - DS3/E3/STS1_CLK_IN - DS3/E3/STS-1 Line Interface Clock Input - Channel 6:</p> <p>This input accepts a recovered DS3, E3 or STS-1 clock signal (from a DS3/E3/STS-1 LIU IC). This input pin should be connected to the RCLK output of the DS3/E3/STS-1 LIU IC (corresponding to channel 6). The XRT94L43 uses this clock signal to sample and latch the data that is applied to the DS3/E3/STS1_DATA_IN_6 input pin number AD24.</p> <p>By default, the data that is applied to the DS3/E3/STS1_DATA_IN_6 input pin will be latched into the XRT94L43 upon the falling edge of this clock signal.</p> <p>For DS3/E3 Applications</p> <p>The XRT94L43 can be configured to latch the DS3/E3/STS1_DATA_IN_6 signal upon the rising edge of this clock signal by setting Bit 1 (DS3/E3/STS1_CLK_IN Invert), within the I/O Control Register - Channel 6 (Indirect Address = 0x7E, 0x01), (Direct Address = 0x7F01) to a "1".</p> <p>For STS-1 Applications</p> <p>The XRT94L43 can not be configured to sample the DS3/E3/STS1_DATA_IN_6 signal upon the rising edge of this clock signal.</p>

STS-3/STM-1 TELECOM BUS INTERFACE - TRANSMIT DIRECTION

PIN #	SIGNAL NAME	I/O	SIGNAL TYPE	DESCRIPTION
AB22	STS3TxA_D_2_7 DS3/E3/ STS1_Clk_IN_10 TxSBData_7	I	TTL	<p>Transmit STS-3/STM-1 Telecom Bus - Channel 2 - Input Data Bus Pin Number 7/DS3/E3 Framer or Receive STS-1 TOH Processor block line interface clock input Pin - Channel 10:</p> <p>The function of this pin depends upon whether or not the STS-3/STM-1 Telecom Bus Interface, associated with Channel 2 is enabled.</p> <p>If STS-3/STM-1 Telecom Bus (Channel 2) has been enabled - STS-3/STM-1 Transmit Telecom Bus - Input Data Bus Pin Number 7: STS3TxA_D_2_7:</p> <p>This input pin along with STS3TxA_D_2[6:0] function as the STS-3/STM-1 Transmit (Add) Telecom Bus - Input Data Bus for Channel 2. The STS-3/STM-1 Telecom Bus interface will sample and latch this pin upon the falling edge of STS3TxA_CLK_2.</p> <p><i>NOTE: This input pin functions as the MSB (Most Significant Bit) of the Transmit (Add) Telecom Bus, for Channel 2.</i></p> <p>If STS-3/STM-1 Telecom Bus (Channel 2) is disabled - DS3/E3/STS1_CLK_IN - DS3/E3/STS-1 Line Interface Clock Input - Channel 10:</p> <p>This input accepts a recovered DS3, E3 or STS-1 clock signal (from a DS3/E3/STS-1 LIU IC). This input pin should be connected to the RCLK output of the DS3/E3/STS-1 LIU IC (corresponding to channel 10). The XRT94L43 uses this clock signal to sample and latch the data that is applied to the DS3/E3/STS1_DATA_IN_10 input pin number AF25.</p> <p>By default, the data that is applied to the DS3/E3/STS1_DATA_IN_10 input pin will be latched into the XRT94L43 upon the falling edge of this clock signal.</p> <p>For DS3/E3 Applications</p> <p>The XRT94L43 can be configured to latch the DS3/E3/STS1_DATA_IN_10 signal upon the rising edge of this clock signal by setting Bit 1 (DS3/E3/STS1_CLK_IN Invert), within the I/O Control Register - Channel 10 (Indirect Address = 0xBE, 0x01), (Direct Address = 0xBF01) to a "1".</p> <p>For STS-1 Applications</p> <p>The XRT94L43 can not be configured to sample the DS3/E3/STS1_DATA_IN_10 signal upon the rising edge of this clock signal.</p>

STS-3/STM-1 TELECOM BUS INTERFACE - TRANSMIT DIRECTION

PIN #	SIGNAL NAME	I/O	SIGNAL TYPE	DESCRIPTION
AC18	STS3TxA_D_3_0 RLOOP_3 TxSBDData_0	I/O	TTL/ CMOS	<p>Transmit STS-3/STM-1 Telecom Bus - Channel 3 - Input Data Bus Pin Number 0/RLOOP_3 General Purpose) output Pin:</p> <p>The function of this pin depends upon whether or not the STS-3/STM-1 Telecom Bus Interface, associated with Channel 2 is enabled.</p> <p>If STS-3/STM-1 Telecom Bus (Channel 3) has been enabled - STS-3/STM-1 Transmit Telecom Bus - Input Data Bus Pin Number 0:</p> <p>This input pin along with STS3TxA_D_3[7:1] function as the STS-3/STM-1 Transmit (Add) Telecom Bus - Input Data Bus for Channel 3. This input pin functions as the LSB (Least Significant Bit) input pin on the Transmit (Add) Telecom Bus - Input Data Bus. The STS-3/STM-1 Telecom Bus interface will sample and latch this pin upon the falling edge of STS3TxA_CLK_3. The LSB of any byte, which is being input into the STS-3/STM-1 Transmit Telecom Bus - Data Bus (for Channel 3) should be input via this pin.</p> <p>If STS-3/STM-1 Telecom Bus (Channel 3) is disabled - RLOOP_3 (General Purpose) output Pin.</p> <p>This output pin can be used as a general purpose output pin. The state of this output pin can be controlled by writing the appropriate value into Bit 1 (RLOOP) within the Line Interface Drive Register associated with Channel 3 (Indirect Address = 0x4E, 0x80), (Direct Address = 0x4F80).</p> <p>NOTE: For Product Legacy purposes, this pin is called RLOOP_3 because one possible application is to tie this output pin to an RLOOP (Remote Loop-back) input pin from one of Exar's XRT73L0X/XRT75L0X DS3/E3/STS-1 LIU devices. However, this output pin, and the corresponding register bit can be used for any purpose.</p>

STS-3/STM-1 TELECOM BUS INTERFACE - TRANSMIT DIRECTION

PIN #	SIGNAL NAME	I/O	SIGNAL TYPE	DESCRIPTION
AB18	STS3TxA_D_3_1 REQ_3 TxSBData_1	I/O	TTL/ CMOS	<p>Transmit STS-3/STM-1 Telecom Bus - Channel 3 - Input Data Bus Pin Number 1/REQ_3 (General Purpose) output Pin:</p> <p>The function of this pin depends upon whether or not the STS-3/STM-1 Telecom Bus Interface, associated with Channel 3 is enabled.</p> <p>If STS-3/STM-1 Telecom Bus (Channel 3) has been enabled - STS-3/STM-1 Transmit Telecom Bus - Input Data Bus Pin Number 1:</p> <p>This input pin along with STS3TxA_D_3[7:2] and STS3TxA_D_3_0 function as the STS-3/STM-1 Transmit (Add) Telecom Bus - Input Data Bus for Channel 3. The STS-3/STM-1 Telecom Bus interface will sample and latch this pin upon the falling edge of STS3TxA_CLK_3.</p> <p>If STS-3/STM-1 Telecom Bus (Channel 3) is disabled - REQ_3 (General Purpose) output Pin.</p> <p>This output pin can be used as a general purpose output pin.</p> <p>The state of this output pin can be controlled by writing the appropriate value into Bit 5 (REQB) within the Line Interface Drive Register associated with Channel 3 (Indirect Address = 0x4E, 0x80), (Direct Address = 0x4F80).</p> <p>NOTE: For Product Legacy purposes, this pin is called REQ_3 because one possible application is to tie this output pin to an REQB (Receive Equalizer By-Pass) or REQEN (Receive Equalizer Enable) input pin from one of Exar's XRT73L0X/ XRT75L0X DS3/E3/STS-1 LIU devices. However, this output pin, and the corresponding register bit can be used for any purpose.</p>

STS-3/STM-1 TELECOM BUS INTERFACE - TRANSMIT DIRECTION

PIN #	SIGNAL NAME	I/O	SIGNAL TYPE	DESCRIPTION
AA20	STS3TxA_D_3_2 DS3/E3/ STS1_Data_IN_3 TxSBData_2	I	TTL	<p>Transmit STS-3/STM-1 Telecom Bus - Channel 3 - Input Data Bus Pin Number 2/DS3/E3 Framer or Receive STS-1 TOH Processor block line interface input Pin - Channel 3:</p> <p>The function of this pin depends upon whether or not the STS-3/STM-1 Telecom Bus Interface, associated with Channel 3 is enabled.</p> <p>If STS-3/STM-1 Telecom Bus (Channel 3) has been enabled - STS-3/STM-1 Transmit Telecom Bus - Input Data Bus Pin Number 2: STS3TxA_D_3_2:</p> <p>This input pin along with STS3TxA_D_3[7:3] and STS3TxA_D_3[1:0] function as the STS-3/STM-1 Transmit (Add) Telecom Bus - Input Data Bus for Channel 3. The STS-3/STM-1 Telecom Bus interface will sample and latch this pin upon the falling edge of STS3TxA_CLK_3.</p> <p>If STS-3/STM-1 Telecom Bus (Channel 3) is disabled - DS3/E3/STS1_DATA_IN - DS3/E3/STS-1 Line Interface Data Input - Channel 3:</p> <p>This input accepts single-rail, recovered DS3, E3 or STS-1 data (from a DS3/E3/STS-1 LIU IC). This input pin should be connected to the RPOS output of the DS3/E3/STS-1 LIU IC (corresponding to channel 3).</p> <p>By default, the data that is applied to this input pin will be latched into the XRT94L43 upon the falling edge of the DS3/E3/STS1_CLK_IN_3 signal pin number AD22.</p> <p>For DS3/E3 Applications</p> <p>The XRT94L43 can be configured to latch this input signal upon the rising edge of the DS3/E3/STS1_CLK_IN_3 signal by setting Bit 1 (DS3/E3/STS1_CLK_IN Invert), within the I/O Control Register - Channel 3 (Indirect Address = 0x4E, 0x01), (Direct Address = 0x4F01) to a "1".</p> <p>For STS-1 Applications</p> <p>The XRT94L43 can not be configured to sample the DS3/E3/STS1_DATA_IN_3 signal upon the rising edge of DS3/E3/STS1_CLK_IN_3.</p>

STS-3/STM-1 TELECOM BUS INTERFACE - TRANSMIT DIRECTION

PIN #	SIGNAL NAME	I/O	SIGNAL TYPE	DESCRIPTION
AB19	STS3TxA_D_3_3 DS3/E3/ STS1_Data_IN_7 TxSBData_3	I	TTL	<p>Transmit STS-3/STM-1 Telecom Bus - Channel 3 - Input Data Bus Pin Number 3/DS3/E3 Framer or Receive STS-1 TOH Processor block line interface input Pin - Channel 7:</p> <p>The function of this pin depends upon whether or not the STS-3/STM-1 Telecom Bus Interface, associated with Channel 3 is enabled.</p> <p>If STS-3/STM-1 Telecom Bus (Channel 3) has been enabled - STS-3/STM-1 Transmit Telecom Bus - Input Data Bus Pin Number 3: STS3TxA_D_3_3:</p> <p>This input pin along with STS3TxA_D_3[7:4] and STS3TxA_D_3[2:0] function as the STS-3/STM-1 Transmit (Add) Telecom Bus - Input Data Bus for Channel 3. The STS-3/STM-1 Telecom Bus interface will sample and latch this pin upon the falling edge of STS3TxA_CLK_3.</p> <p>If STS-3/STM-1 Telecom Bus (Channel 3) is disabled - DS3/E3/STS1_DATA_IN - DS3/E3/STS-1 Line Interface Data Input - Channel 7:</p> <p>This input accepts single-rail, recovered DS3, E3 or STS-1 data (from a DS3/E3/STS-1 LIU IC). This input pin should be connected to the RPOS output of the DS3/E3/STS-1 LIU IC (corresponding to channel 7).</p> <p>By default, the data that is applied to this input pin will be latched into the XRT94L43 upon the falling edge of the DS3/E3/STS1_CLK_IN_7 signal pin number AA19.</p> <p>For DS3/E3 Applications</p> <p>The XRT94L43 can be configured to latch this input signal upon the rising edge of the DS3/E3/STS1_CLK_IN_7 signal by setting Bit 1 (DS3/E3/STS1_CLK_IN Invert), within the I/O Control Register - Channel 7 (Indirect Address = 0x8E, 0x01), (Direct Address = 0x8F01) to a "1".</p> <p>For STS-1 Applications</p> <p>The XRT94L43 can not be configured to sample the DS3/E3/STS1_DATA_IN_7 signal upon the rising edge of DS3/E3/STS1_CLK_IN_7.</p>

STS-3/STM-1 TELECOM BUS INTERFACE - TRANSMIT DIRECTION

PIN #	SIGNAL NAME	I/O	SIGNAL TYPE	DESCRIPTION
AD16	STS3TxA_D_3_4 DS3/E3/ STS1_Data_IN_11 TxSBDData_4	I	TTL	<p>Transmit STS-3/STM-1 Telecom Bus - Channel 3 - Input Data Bus Pin Number 4/DS3/E3 Framer or Receive STS-1 TOH Processor block line interface input Pin - Channel 11 (DS3/E3/ STS1_DATA_IN_11):</p> <p>The function of this pin depends upon whether or not the STS-3/STM-1 Telecom Bus Interface, associated with Channel 3 is enabled.</p> <p>If STS-3/STM-1 Telecom Bus (Channel 3) has been enabled - STS-3/STM-1 Transmit Telecom Bus - Input Data Bus Pin Number 4: STS3TxA_D_3_4:</p> <p>This input pin along with STS3TxA_D_3[7:5] and STS3TxA_D_3[3:0] function as the STS-3/STM-1 Transmit (Add) Telecom Bus - Input Data Bus for Channel 3. The STS-3/STM-1 Telecom Bus interface will sample and latch this pin upon the falling edge of STS3TxA_CLK_3.</p> <p>If STS-3/STM-1 Telecom Bus (Channel 3) is disabled - DS3/E3/ STS1_DATA_IN - DS3/E3/STS-1 Line Interface Data Input - Channel 11:</p> <p>This input accepts single-rail, recovered DS3, E3 or STS-1 data (from a DS3/E3/STS-1 LIU IC). This input pin should be connected to the RPOS output of the DS3/E3/STS-1 LIU IC (corresponding to channel 11).</p> <p>By default, the data that is applied to this input pin will be latched into the XRT94L43 upon the falling edge of the DS3/E3/ STS1_CLK_IN_11 signal pin number AB16.</p> <p>For DS3/E3 Applications</p> <p>The XRT94L43 can be configured to latch this input signal upon the rising edge of the DS3/E3/STS1_CLK_IN_11 signal by setting Bit 1 (DS3/E3/STS1_CLK_IN Invert), within the I/O Control Register - Channel 11 (Indirect Address = 0xCE, 0x01), (Direct Address = 0xCF01) to a "1".</p> <p>For STS-1 Applications</p> <p>The XRT94L43 can not be configured to sample the DS3/E3/ STS1_DATA_IN_11 signal upon the rising edge of DS3/E3/ STS1_CLK_IN_11.</p>

STS-3/STM-1 TELECOM BUS INTERFACE - TRANSMIT DIRECTION

PIN #	SIGNAL NAME	I/O	SIGNAL TYPE	DESCRIPTION
AD22	STS3TxA_D_3_5 DS3/E3/ STS1_CLK_IN_3 TxSBData_5	I	TTL	<p>Transmit STS-3/STM-1 Telecom Bus - Channel 3 - Input Data Bus Pin Number 5/DS3/E3 Framer or Receive STS-1 TOH Processor block line interface clock input Pin - Channel 3:</p> <p>The function of this pin depends upon whether or not the STS-3/STM-1 Telecom Bus Interface, associated with Channel 3 is enabled.</p> <p>If STS-3/STM-1 Telecom Bus (Channel 3) has been enabled - STS-3/STM-1 Transmit Telecom Bus - Input Data Bus Pin Number 5: STS3TxA_D_3_5:</p> <p>This input pin along with STS3TxA_D_3[7:6] and STS3TxA_D_3[4:0] function as the STS-3/STM-1 Transmit (Add) Telecom Bus - Input Data Bus for Channel 3. The STS-3/STM-1 Telecom Bus interface will sample and latch this pin upon the falling edge of STS3TxA_CLK_3.</p> <p>If STS-3/STM-1 Telecom Bus (Channel 3) is disabled - DS3/E3/STS1_CLK_IN - DS3/E3/STS-1 Line Interface Clock Input - Channel 3:</p> <p>This input accepts a recovered DS3, E3 or STS-1 clock signal (from a DS3/E3/STS-1 LIU IC). This input pin should be connected to the RCLK output of the DS3/E3/STS-1 LIU IC (corresponding to channel 3). The XRT94L43 uses this clock signal to sample and latch the data that is applied to the DS3/E3/STS1_DATA_IN_3 input pin number AA20.</p> <p>By default, the data that is applied to the DS3/E3/STS1_DATA_IN_3 input pin will be latched into the XRT94L43 upon the falling edge of this clock signal.</p> <p>For DS3/E3 Applications</p> <p>The XRT94L43 can be configured to latch the DS3/E3/STS1_DATA_IN_3 signal upon the rising edge of this clock signal by setting Bit 1 (DS3/E3/STS1_CLK_IN Invert), within the I/O Control Register - Channel 3 (Indirect Address = 0x4E, 0x01), (Direct Address = 0x4F01) to a "1".</p> <p>For STS-1 Applications</p> <p>The XRT94L43 can not be configured to sample the DS3/E3/STS1_DATA_IN_3 signal upon the rising edge of this clock signal.</p>

STS-3/STM-1 TELECOM BUS INTERFACE - TRANSMIT DIRECTION

PIN #	SIGNAL NAME	I/O	SIGNAL TYPE	DESCRIPTION
AA19	STS3TxA_D_3_6 DS3/E3/ STS1_CLK_IN_7 TxSBDData_6	I	TTL	<p>Transmit STS-3/STM-1 Telecom Bus - Channel 3 - Input Data Bus Pin Number 6/DS3/E3 Framer or Receive STS-1 TOH Processor block line interface clock input Pin - Channel 7:</p> <p>The function of this pin depends upon whether or not the STS-3/STM-1 Telecom Bus Interface, associated with Channel 3 is enabled.</p> <p>If STS-3/STM-1 Telecom Bus (Channel 3) has been enabled - STS-3/STM-1 Transmit Telecom Bus - Input Data Bus Pin Number 6: STS3TxA_D_3_6:</p> <p>This input pin along with STS3TxA_D_3_7 and STS3TxA_D_3[5:0] function as the STS-3/STM-1 Transmit (Add) Telecom Bus - Input Data Bus for Channel 3. The STS-3/STM-1 Telecom Bus interface will sample and latch this pin upon the falling edge of STS3TxA_CLK_3.</p> <p>If STS-3/STM-1 Telecom Bus (Channel 3) is disabled - DS3/E3/STS1_CLK_IN - DS3/E3/STS-1 Line Interface Clock Input - Channel 7:</p> <p>This input accepts a recovered DS3, E3 or STS-1 clock signal (from a DS3/E3/STS-1 LIU IC). This input pin should be connected to the RCLK output of the DS3/E3/STS-1 LIU IC (corresponding to channel 7). The XRT94L43 uses this clock signal to sample and latch the data that is applied to the DS3/E3/STS1_DATA_IN_7 input pin number AB19.</p> <p>By default, the data that is applied to the DS3/E3/STS1_DATA_IN_7 input pin will be latched into the XRT94L43 upon the falling edge of this clock signal.</p> <p>For DS3/E3 Applications</p> <p>The XRT94L43 can be configured to latch the DS3/E3/STS1_DATA_IN_7 signal upon the rising edge of this clock signal by setting Bit 1 (DS3/E3/STS1_CLK_IN Invert), within the I/O Control Register - Channel 7 (Indirect Address = 0x8E, 0x01), (Direct Address = 0x8F01) to a "1".</p> <p>For STS-1 Applications</p> <p>The XRT94L43 can not be configured to sample the DS3/E3/STS1_DATA_IN_7 signal upon the rising edge of this clock signal.</p>

STS-3/STM-1 TELECOM BUS INTERFACE - TRANSMIT DIRECTION

PIN #	SIGNAL NAME	I/O	SIGNAL TYPE	DESCRIPTION
AB16	STS3TxA_D_3_7 DS3/E3/ STS1_CLK_IN_11 TxSBData_7	I	TTL	<p>Transmit STS-3/STM-1 Telecom Bus - Channel 3 - Input Data Bus Pin Number 7/DS3/E3 Framer or Receive STS-1 TOH Processor block line interface clock input Pin - Channel 11:</p> <p>The function of this pin depends upon whether or not the STS-3/STM-1 Telecom Bus Interface, associated with Channel 3 is enabled.</p> <p>If STS-3/STM-1 Telecom Bus (Channel 3) has been enabled - STS-3/STM-1 Transmit Telecom Bus - Input Data Bus Pin Number 7: STS3TxA_D_3_7:</p> <p>This input pin along with STS3TxA_D_3[6:0] function as the STS-3/STM-1 Transmit (Add) Telecom Bus - Input Data Bus for Channel 3. The STS-3/STM-1 Telecom Bus interface will sample and latch this pin upon the falling edge of STS3TxA_CLK_3.</p> <p><i>NOTE: This input pin functions as the MSB (Most Significant Bit) of the Transmit (Add) Telecom Bus, for Channel 3.</i></p> <p>If STS-3/STM-1 Telecom Bus (Channel 3) is disabled - DS3/E3/STS1_CLK_IN - DS3/E3/STS-1 Line Interface Clock Input - Channel 11:</p> <p>This input accepts a recovered DS3, E3 or STS-1 clock signal (from a DS3/E3/STS-1 LIU IC). This input pin should be connected to the RCLK output of the DS3/E3/STS-1 LIU IC (corresponding to channel 11). The XRT94L43 uses this clock signal to sample and latch the data that is applied to the DS3/E3/STS1_DATA_IN_11 input pin number AD16.</p> <p>By default, the data that is applied to the DS3/E3/STS1_DATA_IN_11 input pin will be latched into the XRT94L43 upon the falling edge of this clock signal.</p> <p>For DS3/E3 Applications</p> <p>The XRT94L43 can be configured to latch the DS3/E3/STS1_DATA_IN_11 signal upon the rising edge of this clock signal by setting Bit 1 (DS3/E3/STS1_CLK_IN Invert), within the I/O Control Register - Channel 11 (Indirect Address = 0xCE, 0x01), (Direct Address = 0xCF01) to a "1".</p> <p>For STS-1 Applications</p> <p>The XRT94L43 can not be configured to sample the DS3/E3/STS1_DATA_IN_11 signal upon the rising edge of this clock signal.</p>

STS-3/STM-1 TELECOM BUS INTERFACE - TRANSMIT DIRECTION

PIN #	SIGNAL NAME	I/O	SIGNAL TYPE	DESCRIPTION
AB25	TxREFCLK SSE_POS	O	CMOS	<p>Transmit STS-3/STM-1 Telecom Bus Reference Clock Output Pin/Slow-Speed Interface - Egress - Positive Data I/O:</p> <p>The exact function of this pin depends upon whether or not the STS-3/STM-1 Telecom Bus is enabled, and whether the Slow-Speed Interface is enabled.</p> <p>Transmit STS-3/STM-1 Telecom Bus Reference Clock Output Pin:</p> <p>This pin generates a 19.44MHz clock signal that is ultimately derived from the Clock Synthesizer block (within the XRT94L43).</p> <p>If the user configures the STS-3/STM-1 Telecom Bus Interface to operate in the "Re-Phase OFF" mode, then the device (or entity) that is transmitting STS-3/STM-1 data (to the Transmit STS-3/STM-1 Telecom Bus Interface) must synchronize its data transmission to this output signal.</p> <p>The user is not required to use this signal if the STS-3/STM-1 Telecom Bus Interface has been configured to operate in the "Re-Phase ON" Mode.</p> <p>SSE_POS (Slow-Speed Interface - Egress - Port is enabled):</p> <p>If the Slow-Speed Interface - Egress (SSE) Port is enabled, then this pin will function as either the SSE_POS output pin or the SSE_POS input pin. If the user configures the SSE port to operate in the "Insert" Mode, then the SSE port will be configured to replace any "user-selected" Egress DS3/E3 or STS-1 data-stream (within the XRT94L43) with the data that is applied to the SSE_POS and SSE_NEG input pins. More specifically, in the "Insert" Mode, this pin will function as the "SSE_POS" input pin. In this case, the SSE port will sample and latch the contents of the input pin (along with the SSE_NEG, in a Dual-Rail manner) upon the falling edge of the SSE_CLK input clock signal.</p> <p>If the user configures the SSE port to operate in the "Extract" Mode, then the SSE port will output any "user-selected" Egress DS3/E3 or STS-1 signal (within the XRT94L43) via this output port. More specifically, in the "Extract Mode" this pin will function as the "SSE_POS" output pin. In this case, the SSE port will output data via this pin, along with the SSE_POS output pin (in a Dual-Rail Manner) upon the rising edge of the SSE_CLK output signal.</p>

STS-3/STM-1 TELECOM BUS INTERFACE - TRANSMIT DIRECTION

PIN #	SIGNAL NAME	I/O	SIGNAL TYPE	DESCRIPTION
AA24	TxSBFP_OUT SSI_NEG	O	CMOS	<p>Transmit STS-3/STM-1 Telecom Bus Framing Pulse Output Pin: This pin generates a pulse at an 8kHz rate. This signal is ultimately derived from the Clock Synthesizer block (within the XRT94L43). If the STS-3/STM-1 Telecom Bus Interface is configured to operate in the "Re-Phase OFF" Mode, then the devices (or entities) that are transmitting STS-3/STM-1 data (to the Transmit STS-3/STM-1 Telecom Bus Interface) must synchronize their STS-3/STM-1 frame transmission to this output signal. In the Re-Phase OFF Mode, each device or entity must align their STS-3/STM-1 Frame transmission to this signal, in order to insure that all four Transmit STS-3/STM-1 Telecom Bus Interfaces are presented with TOH data simultaneously.</p> <p>Transmit STS-3/STM-1 Telecom Bus Framing Pulse Output Pin/ Slow-Speed Interface - Ingress - Negative Data I/O: The exact function of this pin depends upon whether or not the STS-3/STM-1 Telecom Bus is enabled and whether the Slow-Speed Interface is enabled.</p> <p>Transmit STS-3/STM-1 Telecom Bus Framing Pulse Output Pin: This pin generates a pulse at an 8kHz rate. This signal is ultimately derived from the Clock Synthesizer block (within the XRT94L43). If the user configures the STS-3/STM-1 Telecom Bus Interface to operate in the "Re-Phase OFF" Mode, then the devices (or entities) that is transmitting STS-3/STM-1 data (to the Transmit STS-3/STM-1 Telecom Bus Interface) must synchronize its STS-3/STM-1 frame transmission to this output signal. In the Re-Phase OFF Mode, each device or entity must align their STS-3/STM-1 Frame transmission to this signal, in order to insure that all four Transmit STS-3/STM-1 Telecom Bus Interfaces are presented with TOH data simultaneously.</p> <p>SSI_NEG (Slow-Speed Interface - Ingress Port is enabled): If the Slow-Speed Interface - Ingress (SSI) Port is enabled, then this pin will function as either the SSI_NEG output pin or the SSI_NEG input pin. If the user configures the SSI port to operate in the "Insert" Mode, then the SSI port will be configured to replace any "user-selected" Ingress DS3/E3 or STS-1 data-stream (within the XRT94L43) with the data that is applied to the SSI_POS and SSI_NEG input pins. More specifically, in the "Insert" Mode, this pin will function as the SSI_NEG input pin. In this case, the SSI port will sample and latch the contents of this input pin (along with the SSI_POS input pin, in a Dual-Rail Manner) upon the falling edge of the SSI_CLK input clock signal. If the user configures the SSI port to operate in the "Extract" Mode, then the SSI port will output any "user-selected" Ingress DS3/E3 or STS-1 signal (within the XRT94L43) via this output port. More specifically, in the "Extract Mode" this pin will function as the "SSI_NEG" output pin. In this case, the SSI port will output data via this pin, along with the SSI_POS output pin (in a Dual-Rail Manner) upon the rising edge of the SSI_CLK output signal.</p>

RXSTS-1 TOH/POH INTERFACE

PIN #	SIGNAL NAME	I/O	SIGNAL TYPE	DESCRIPTION
A14 F20 K25 AD18 E16 H22 AA25 AC15 E19 K22 AD23 AA12	RxSTS1OHSel_0 RxSTS1OHSel_1 RxSTS1OHSel_2 RxSTS1OHSel_3 RxSTS1OHSel_4 RxSTS1OHSel_5 RxSTS1OHSel_6 RxSTS1OHSel_7 RxSTS1OHSel_8 RxSTS1OHSel_9 RxSTS1OHSel_10 RxSTS1OHSel_11	O	CMOS	<p>Receive STS-1 TOH and POH Output Port - POH Data Indicator:</p> <p>These output pins, along with RxSTS1OHClk_n, RxSTS1OHFrame_n and RxSTS1OH_n function as the Receive STS-1 TOH and POH Output Port.</p> <p>These output pins indicate whether POH or TOH data is being output via the RxSTS1OH_n output pins.</p> <p>These output pins will toggle "High" coincident with the POH data as it is being output via the RxSTS1OH_n output pins. Conversely, these output pins will toggle "Low" coincident with the TOH data as it is being output via the RxSTS1OH_n output pins.</p> <p>NOTE: <i>These output pins are updated upon the falling edge of RxSTS1OHClk_n. As a consequence, external circuitry, receiving this data, should sample this data upon the rising edge of RxSTS1OHClk_n.</i></p>
D11 G22 U23 AD20 B15 J21 AA26 AF15 E17 K23 AF26 AD11	RxSTS1OH_0 RxSTS1OH_1 RxSTS1OH_2 RxSTS1OH_3 RxSTS1OH_4 RxSTS1OH_5 RxSTS1OH_6 RxSTS1OH_7 RxSTS1OH_8 RxSTS1OH_9 RxSTS1OH_10 RxSTS1OH_11	O	CMOS	<p>Receive STS-1 TOH and POH Output Port - Output pin:</p> <p>These output pins, along with RxSTS1OHSel_n, RxSTS1OHClk_n and RxSTS1OHFrame_n function as the Receive STS-1 TOH and POH Output Port.</p> <p>Each bit, within the TOH and POH bytes (within the incoming STS-1 data stream) is updated upon the falling edge of RxSTS1OHClk_n. As a consequence, external circuitry receiving this data, should sample this data upon the rising edge of RxSTS1OHClk_n.</p> <p>NOTES:</p> <ol style="list-style-type: none"> <i>The external circuitry can determine whether or not it is receiving POH or TOH data via this output pin. The RxSTS1OHSel_n output pin will be "High" anytime POH data is being output via these output pins. Conversely, the RxSTS1OHSel_n output pin will be "Low" anytime TOH data is being output via these output pins.</i> <i>TOH and POH data, associated with Receive STS-1 TOH and POH Processor Block - Channel 0 will be output via the RxSTS1OH_0, and so on.</i>

RXSTS-1 TOH/POH INTERFACE

PIN #	SIGNAL NAME	I/O	SIGNAL TYPE	DESCRIPTION
F12 F22 T24 AE20 A18 H21 AB24 AE16 E18 K26 AA23 AF10	RxSTS1OHClk_0 RxSTS1OHClk_1 RxSTS1OHClk_2 RxSTS1OHClk_3 RxSTS1OHClk_4 RxSTS1OHClk_5 RxSTS1OHClk_6 RxSTS1OHClk_7 RxSTS1OHClk_8 RxSTS1OHClk_9 RxSTS1OHClk_10 RxSTS1OHClk_11	O	CMOS	<p>Receive STS-1 TOH and POH Output Port - Clock Output signal:</p> <p>These output pins, along with RxSTS1OH_n, RxSTS1OHFrame_n, and RxSTS1OHSel_n function as the Receive STS-1 TOH and POH Output Port.</p> <p>These output pins function as the Clock Output signals for the Receive STS-1 TOH and POH Output Port. The RxSTS1OH_n, RxSTS1Frame_n and RxSTS1OHSel_n output pins are updated upon the falling edge of this clock signal.</p>
D12 E22 U26 AF18 B17 J22 W22 AF12 F19 K24 AF23 AD10	RxSTS1OHFrame_0 RxSTS1OHFrame_1 RxSTS1OHFrame_2 RxSTS1OHFrame_3 RxSTS1OHFrame_4 RxSTS1OHFrame_5 RxSTS1OHFrame_6 RxSTS1OHFrame_7 RxSTS1OHFrame_8 RxSTS1OHFrame_9 RxSTS1OHFrame_10 RxSTS1OHFrame_11	O	CMOS	<p>Receive STS-1 TOH and POH Output Port - Frame Boundary Indicator:</p> <p>These output pins, along with RxSTS1OH_n, RxSTS1OHSel_n and RxSTS1OHClk_n function as the Receive STS-1 TOH and POH Output Port.</p> <p>These output pins will pulse "High" coincident with either of the following events.</p> <ol style="list-style-type: none"> 1. When the very first TOH byte (A1), of a given STS-1 frame, is being output via the corresponding RxSTS1OH_n output pin. 2. When the very first POH byte (J1), of a given STS-1 frame, is being output via the corresponding RxSTS1OH_n output pin. <p>NOTE: The external circuitry can determine whether these output pins are pulsing "High" for the first TOH or POH byte by checking the state of the corresponding RxSTS1OHSel_n output pin.</p>

STS-3/STM-1 TELECOM BUS INTERFACE - RECEIVE DIRECTION

PIN #	SIGNAL NAME	I/O	SIGNAL TYPE	DESCRIPTION
A20	STS3RxD_CLK_0 RxSBCIKLLOOP_0	O	CMOS	<p>Receive STS-3/STM-1 Telecom Bus Clock Output - Channel 0; LLOOP_0 (General Purpose) Output Pin:</p> <p>The function of this input pin depends upon whether or not the STS-3/STM-1 Telecom Bus Interface associated with Channel 0 is enabled.</p> <p>If STS-3/STM-1 Telecom Bus (Channel 0) has been enabled - STS-3/STM-1 Receive Telecom Bus Clock Output - Channel 0; STS3RxD_CLK_0:</p> <p>All signals, which is output via the Receive Telecom Bus - Channel 0 is clocked out upon the rising edge of this clock signal. This includes the following signals.</p> <ul style="list-style-type: none"> • STS3RxD_D_0[7:0] • STS3RxD_ALARM_0 • STS3RxD_DP_0 • STS3RxD_PL_0 • STS3RxD_C1J1_0 <p>This clock signal will operate at 19.44MHz.</p> <p>If STS-3/STM-1 Telecom Bus (Channel 0) is disabled - LLOOP_0 (General Purpose) Output Pin:</p> <p>This output pin can be used as a general purpose output pin.</p> <p>The state of this output pin can be controlled by writing the appropriate value into Bit 0 (LLOOP) within the Line Interface Drive Register associated with Channel 0 (Indirect Address = 0x1E, 0x80), (Direct Address = 0x1F80).</p> <p>NOTE: For Product Legacy purposes, this pin is called LLOOP_0 because one possible application is to tie this output pin to an LLOOP (Local Loop-back) input pin from one of Exar's XRT73L0X/XRT75L0X DS3/E3/STS-1 LIU devices. However, this output pin, and the corresponding register bit can be used for any purpose.</p>

STS-3/STM-1 TELECOM BUS INTERFACE - RECEIVE DIRECTION

PIN #	SIGNAL NAME	I/O	SIGNAL TYPE	DESCRIPTION
D23	STS3RxD_CLK_1 RxSBCIKLLOOP_1	O	CMOS	<p>Receive STS-3/STM-1 Telecom Bus Clock Output - Channel 1; LLOOP_1 (General Purpose) Output Pin:</p> <p>The function of this input pin depends upon whether or not the STS-3/STM-1 Telecom Bus Interface associated with Channel 1 is enabled.</p> <p>If STS-3/STM-1 Telecom Bus (Channel 1) has been enabled - STS-3/STM-1 Receive Telecom Bus Clock Output - Channel 1; STS3RxD_CLK_1:</p> <p>All signals, which is output via the Receive Telecom Bus - Channel 1 is clocked out upon the rising edge of this clock signal. This includes the following signals.</p> <ul style="list-style-type: none"> • STS3RxD_D_1[7:0] • STS3RxD_ALARM_1 • STS3RxD_DP_1 • STS3RxD_PL_1 • STS3RxD_C1J1_1 <p>This clock signal will operate at 19.44MHz.</p> <p>If STS-3/STM-1 Telecom Bus (Channel 1) is disabled - LLOOP_1 (General Purpose) Output Pin:</p> <p>This output pin can be used as a general purpose output pin.</p> <p>The state of this output pin can be controlled by writing the appropriate value into Bit 0 (LLOOP) within the Line Interface Drive Register associated with Channel 1 (Indirect Address = 0x2E, 0x80), (Direct Address = 0x2F80).</p> <p>NOTE: For Product Legacy purposes, this pin is called LLOOP_1 because one possible application is to tie this output pin to an LLOOP (Local Loop-back) input pin from one of Exar's XRT73L0X/XRT75L0X DS3/E3/STS-1 LIU devices. However, this output pin, and the corresponding register bit can be used for any purpose.</p>

STS-3/STM-1 TELECOM BUS INTERFACE - RECEIVE DIRECTION

PIN #	SIGNAL NAME	I/O	SIGNAL TYPE	DESCRIPTION
W23	STS3RxD_CLK_2 RxSBCIKLLOOP_2	O	CMOS	<p>Receive STS-3/STM-1 Telecom Bus Clock Output - Channel 2; LLOOP_2 (General Purpose) Output Pin:</p> <p>The function of this input pin depends upon whether or not the STS-3/STM-1 Telecom Bus Interface associated with Channel 2 is enabled.</p> <p>If STS-3/STM-1 Telecom Bus (Channel 2) has been enabled - STS-3/STM-1 Receive Telecom Bus Clock Output - Channel 2; STS3RxD_CLK_2:</p> <p>All signals, which is output via the Receive Telecom Bus - Channel 2 is clocked out upon the rising edge of this clock signal. This includes the following signals.</p> <ul style="list-style-type: none"> • STS3RxD_D_2[7:0] • STS3RxD_ALARM_2 • STS3RxD_DP_2 • STS3RxD_PL_2 • STS3RxD_C1J1_2 <p>This clock signal will operate at 19.44MHz.</p> <p>If STS-3/STM-1 Telecom Bus (Channel 2) is disabled - LLOOP_2 (General Purpose) Output Pin:</p> <p>This output pin can be used as a general purpose output pin.</p> <p>The state of this output pin can be controlled by writing the appropriate value into Bit 0 (LLOOP) within the Line Interface Drive Register associated with Channel 2 (Indirect Address = 0x3E, 0x80), (Direct Address = 0x3F80).</p> <p>NOTE: For Product Legacy purposes, this pin is called LLOOP_2 because one possible application is to tie this output pin to an LLOOP (Local Loop-back) input pin from one of Exar's XRT73L0X/XRT75L0X DS3/E3/STS-1 LIU devices. However, this output pin, and the corresponding register bit can be used for any purpose.</p>

STS-3/STM-1 TELECOM BUS INTERFACE - RECEIVE DIRECTION

PIN #	SIGNAL NAME	I/O	SIGNAL TYPE	DESCRIPTION
AF20	STS3RxD_CLK_3 RxSBCIKLLOOP_3	O	CMOS	<p>Receive STS-3/STM-1 Telecom Bus Clock Output - Channel 3; LLOOP_3 (General Purpose) Output Pin:</p> <p>The function of this input pin depends upon whether or not the STS-3/STM-1 Telecom Bus Interface associated with Channel 3 is enabled.</p> <p>If STS-3/STM-1 Telecom Bus (Channel 3) has been enabled - STS-3/STM-1 Receive Telecom Bus Clock Output - Channel 3; STS3RxD_CLK_3:</p> <p>All signals, which is output via the Receive Telecom Bus - Channel 3 is clocked out upon the rising edge of this clock signal. This includes the following signals.</p> <ul style="list-style-type: none"> • STS3RxD_D_3[7:0] • STS3RxD_ALARM_3 • STS3RxD_DP_3 • STS3RxD_PL_3 • STS3RxD_C1J1_3 <p>This clock signal will operate at 19.44MHz.</p> <p>If STS-3/STM-1 Telecom Bus (Channel 3) is disabled - LLOOP_3 (General Purpose) Output Pin:</p> <p>This output pin can be used as a general purpose output pin.</p> <p>The state of this output pin can be controlled by writing the appropriate value into Bit 0 (LLOOP) within the Line Interface Drive Register associated with Channel 3 (Indirect Address = 0x4E, 0x80), (Direct Address = 0x4F80).</p> <p>NOTE: For Product Legacy purposes, this pin is called LLOOP_3 because one possible application is to tie this output pin to an LLOOP (Local Loop-back) input pin from one of Exar's XRT73L0X/XRT75L0X DS3/E3/STS-1 LIU devices. However, this output pin, and the corresponding register bit can be used for any purpose.</p>

STS-3/STM-1 TELECOM BUS INTERFACE - RECEIVE DIRECTION

PIN #	SIGNAL NAME	I/O	SIGNAL TYPE	DESCRIPTION
A21	STS3RxD_PL_0 TAOS_0	O	CMOS	<p>STS-3/STM-1 Receive (Drop) Telecom Bus - Payload Indicator Output Signal - Channel 0/TAOS_0 (General Purpose) output Pin - Channel 0:</p> <p>The function of this output pin depends upon whether or not the STS-3/STM-1 Telecom Bus Interface block associated with Channel 0 has been enabled or disabled.</p> <p>If the STS-3/STM-1 Telecom Bus Interface (associated with Channel 0) is enabled - STS-3/STS-1 Receive (Drop) Telecom Bus - Payload Indicator Output - STS3RxD_PL_0:</p> <p>This output pin indicates whether or not Transport Overhead bytes are being output via the STS3RXD_D_0[7:0] output pins.</p> <p>This output pin is pulled "Low" for the duration that the STS-3/STM-1 Receive Telecom Bus is transmitting a Transport Overhead byte via the STS3RXD_D_0[7:0] output pins.</p> <p>Conversely, this output pin is pulled "High" for the duration that the STS-3/STM-1 Receive Telecom Bus is transmitting something other than a Transport Overhead byte via the STS3RXD_D_0[7:0] output pins.</p> <p>If the STS-3/STM-1 Telecom Bus Interface (associated with Channel 0) is disabled - TAOS_0 (General Purpose) output Pin - Channel 0:</p> <p>This output pin can be used as a general purpose output pin.</p> <p>The state of this output pin can be controlled by writing the appropriate value into Bit 4 (TAOS) within the Line Interface Drive Register associated with Channel 0 (Indirect Address = 0x1E, 0x80), (Direct Address = 0x1F80).</p> <p>NOTE: For Product Legacy purposes, this pin is called TAOS_0 because one possible application is to tie this output pin to an TAOS (Transmit All Ones) input pin from one of Exar's XRT73L0X/ XRT75L0X DS3/E3/STS-1 LIU devices. However, this output pin, and the corresponding register bit can be used for any purpose.</p>

STS-3/STM-1 TELECOM BUS INTERFACE - RECEIVE DIRECTION

PIN #	SIGNAL NAME	I/O	SIGNAL TYPE	DESCRIPTION
D24	STS3RxD_PL_1 TAOS_1	O	CMOS	<p>STS-3/STM-1 Receive (Drop) Telecom Bus - Payload Indicator Output Signal - Channel 1/TAOS_1 (General Purpose) output Pin - Channel 1:</p> <p>The function of this output pin depends upon whether or not the STS-3/STM-1 Telecom Bus Interface block associated with Channel 1 has been enabled or disabled.</p> <p>If the STS-3/STM-1 Telecom Bus Interface (associated with Channel 1) is enabled - STS-3/STS-1 Receive (Drop) Telecom Bus - Payload Indicator Output - STS3RxD_PL_1:</p> <p>This output pin indicates whether or not Transport Overhead bytes are being output via the STS3RXD_D_1[7:0] output pins.</p> <p>This output pin is pulled "Low" for the duration that the STS-3/STM-1 Receive Telecom Bus is transmitting a Transport Overhead byte via the STS3RXD_D_1[7:0] output pins.</p> <p>Conversely, this output pin is pulled "High" for the duration that the STS-3/STM-1 Receive Telecom Bus is transmitting something other than a Transport Overhead byte via the STS3RXD_D_1[7:0] output pins.</p> <p>If the STS-3/STM-1 Telecom Bus Interface (associated with Channel 1) is disabled - TAOS_1 (General Purpose) output Pin - Channel 1:</p> <p>This output pin can be used as a general purpose output pin.</p> <p>The state of this output pin can be controlled by writing the appropriate value into Bit 4 (TAOS) within the Line Interface Drive Register associated with Channel 1 (Indirect Address = 0x2E, 0x80), (Direct Address = 0x2F80).</p> <p>NOTE: For Product Legacy purposes, this pin is called TAOS_1 because one possible application is to tie this output pin to an TAOS (Transmit All Ones) input pin from one of Exar's XRT73L0X/XRT75L0X DS3/E3/STS-1 LIU devices. However, this output pin, and the corresponding register bit can be used for any purpose.</p>

STS-3/STM-1 TELECOM BUS INTERFACE - RECEIVE DIRECTION

PIN #	SIGNAL NAME	I/O	SIGNAL TYPE	DESCRIPTION
V23	STS3RxD_PL_2 TAOS_2	O	CMOS	<p>STS-3/STM-1 Receive (Drop) Telecom Bus - Payload Indicator Output Signal - Channel 2/TAOS_2 (General Purpose) output Pin - Channel 2:</p> <p>The function of this output pin depends upon whether or not the STS-3/STM-1 Telecom Bus Interface block associated with Channel 2 has been enabled or disabled.</p> <p>If the STS-3/STM-1 Telecom Bus Interface (associated with Channel 2) is enabled - STS-3/STS-1 Receive (Drop) Telecom Bus - Payload Indicator Output - STS3RxD_PL_2:</p> <p>This output pin indicates whether or not Transport Overhead bytes are being output via the STS3RXD_D_2[7:0] output pins.</p> <p>This output pin is pulled "Low" for the duration that the STS-3/STM-1 Receive Telecom Bus is transmitting a Transport Overhead byte via the STS3RXD_D_2[7:0] output pins.</p> <p>Conversely, this output pin is pulled "High" for the duration that the STS-3/STM-1 Receive Telecom Bus is transmitting something other than a Transport Overhead byte via the STS3RXD_D_2[7:0] output pins.</p> <p>If the STS-3/STM-1 Telecom Bus Interface (associated with Channel 2) is disabled - TAOS_2 (General Purpose) output Pin - Channel 2:</p> <p>This output pin can be used as a general purpose output pin.</p> <p>The state of this output pin can be controlled by writing the appropriate value into Bit 4 (TAOS) within the Line Interface Drive Register associated with Channel 2 (Indirect Address = 0x3E, 0x80), (Direct Address = 0x3F80).</p> <p>NOTE: For Product Legacy purposes, this pin is called TAOS_2 because one possible application is to tie this output pin to an TAOS (Transmit All Ones) input pin from one of Exar's XRT73L0X/ XRT75L0X DS3/E3/STS-1 LIU devices. However, this output pin, and the corresponding register bit can be used for any purpose.</p>

STS-3/STM-1 TELECOM BUS INTERFACE - RECEIVE DIRECTION

PIN #	SIGNAL NAME	I/O	SIGNAL TYPE	DESCRIPTION
AF21	STS3RxD_PL_3 TAOS_3	O	CMOS	<p>STS-3/STM-1 Receive (Drop) Telecom Bus - Payload Indicator Output Signal - Channel 3/TAOS_3 (General Purpose) output Pin - Channel 3:</p> <p>The function of this output pin depends upon whether or not the STS-3/STM-1 Telecom Bus Interface block associated with Channel 3 has been enabled or disabled.</p> <p>If the STS-3/STM-1 Telecom Bus Interface (associated with Channel 3) is enabled - STS-3/STS-1 Receive (Drop) Telecom Bus - Payload Indicator Output - STS3RxD_PL_3:</p> <p>This output pin indicates whether or not Transport Overhead bytes are being output via the STS3RXD_D_3[7:0] output pins.</p> <p>This output pin is pulled "Low" for the duration that the STS-3/STM-1 Receive Telecom Bus is transmitting a Transport Overhead byte via the STS3RXD_D_3[7:0] output pins.</p> <p>Conversely, this output pin is pulled "High" for the duration that the STS-3/STM-1 Receive Telecom Bus is transmitting something other than a Transport Overhead byte via the STS3RXD_D_3[7:0] output pins.</p> <p>If the STS-3/STM-1 Telecom Bus Interface (associated with Channel 3) is disabled - TAOS_3 (General Purpose) output Pin - Channel 3:</p> <p>This output pin can be used as a general purpose output pin.</p> <p>The state of this output pin can be controlled by writing the appropriate value into Bit 4 (TAOS) within the Line Interface Drive Register associated with Channel 3 (Indirect Address = 0x4E, 0x80), (Direct Address = 0x4F80) .</p> <p>NOTE: For Product Legacy purposes, this pin is called TAOS_3 because one possible application is to tie this output pin to an TAOS (Transmit All Ones) input pin from one of Exar's XRT73L0X/ XRT75L0X DS3/E3/STS-1 LIU devices. However, this output pin, and the corresponding register bit can be used for any purpose.</p>

STS-3/STM-1 TELECOM BUS INTERFACE - RECEIVE DIRECTION

PIN #	SIGNAL NAME	I/O	SIGNAL TYPE	DESCRIPTION
C23	STS3RxD_C1J1_0 EG_DS3E3_FP_8 TxSTS1FP_8 RxSBFrame_0	O	CMOS	<p>STS-3/STM-1 Receive Telecom Bus - C1/J1 Byte Phase Indicator Output Signal - Channel 0; Egress Direction DS3/E3 Frame Generator Block Framing Pulse Output pin - Channel 8; Transmit STS-1 Framing Pulse Output pin - Channel 8:</p> <p>The function of this output pin depends upon whether or not the STS-3/STM-1 Telecom Bus Interface for STS-3/STM-1 Channel 0 has been enabled.</p> <p>If STS-3/STM-1 Telecom Bus (associated with STS-3/STM-1 Channel 0) has been enabled - STS-3/STM-1 Receive Telecom Bus - C1/J1 Byte Phase Indicator Output Signal:</p> <p>This output pin pulses "High" under the following two conditions.</p> <ol style="list-style-type: none"> 1. Whenever the C1 byte is being output via the STS3RxD_D_0[7:0] output, and 2. Whenever the J1 byte is being output via the STS3RxD_D_0[7:0] output. <p>NOTES:</p> <ol style="list-style-type: none"> 1. The STS-3/STM-1 Receive (Drop) Telecom Bus (associated with Channel 0) will indicate that it is transmitting the C1 byte (via the STS3RxD_D_0[7:0] output pins), by pulsing this output pin "High" (for one period of STS3RXD_CLK_0) and keeping the STS3RXD_PL_0 output pin pulled "Low". 2. The STS-3/STM-1 Receive (Drop) Telecom Bus (associated with Channel 0) will indicate that it is transmitting the J1 byte (via the STS3RxD_D_0[7:0] output pins), by pulsing this output pin "High" (for one period of STS3RXD_CLK_0) while the STS3TXD_PL_0 output pin is pulled "High".

STS-3/STM-1 TELECOM BUS INTERFACE - RECEIVE DIRECTION

PIN #	SIGNAL NAME	I/O	SIGNAL TYPE	DESCRIPTION
C23	<p>STS3RxD_C1J1_0 EG_DS3E3_FP_8 TxSTS1FP_8 RxSBFrame_0</p> <p>CONTINUED</p>	O	CMOS	<p>Continued</p> <p>If STS-3/STM-1 Telecom Bus (associated with STS-3/STM-1 Channel 0) is disabled then the function of this output pin depends upon whether Channel 8 has been configured to operate in either the DS3/E3 or STS-1 Modes):</p> <p>If Channel 8 is configured to operate in the DS3/E3 Mode - EG_DS3E3_FP_8 (Egress Direction - DS3/E3 Framing Pulse Output pin - Channel 8):</p> <p>If the STS-3/STM-1 Telecom Bus (associated with STS-3/STM-1 Channel 0) is disabled and if Channel 8 is configured to operate in either the DS3 or E3 Modes then this pin will function as the "Egress Direction DS3/E3 Framing Pulse" output pin.</p> <p>In this mode, the Frame Generator block (associated with Channel 8) will pulse this output pin "HIGH" for one DS3/E3 bit-period, coincident with the first bit (within a given DS3 or E3 frame) being output via the "DS3/E3/STS1_Data_OUT_8" output pin.</p> <p>If Channel 8 is configured to operate in the STS-1 Mode - TxSTS1_FP_8 (Transmit Direction - STS-1 Framing Pulse Output pin - Channel 8):</p> <p>If the STS-3/STM-1 Telecom Bus (associated with STS-3/STM-1 Channel 0) is disabled and if Channel 8 is configured to operate in the STS-1/STM-0 Mode, then this pin will function as the "Transmit Direction STS-1 Framing Pulse" output pin</p> <p>.In this mode, the Transmit STS-1 TOH Processor block (associated with Channel 8) will pulse this output pin "HIGH" for one STS-1 bit-period, coincident to whenever the very first bit (within a given STS-1 frame) being output via the "DS3/E3/STS1_DATA_OUT_8" output pin.</p> <p>NOTE: For those applications in which the XRT94L43 is being interfaced to DS3/E3/STS-1 LIU devices, we recommend that the user NOT connect this output pin to any LIU input pin.</p>
J25	<p>STS3RxD_C1J1_1 EG_DS3E3_FP_9 TxSTS1FP_9 RxSBFrame_1</p>	O	CMOS	<p>STS-3/STM-1 Receive Telecom Bus - C1/J1 Byte Phase Indicator Output Signal - Channel 1; Egress Direction DS3/E3 Frame Generator Framing Pulse Output pin - Channel 9; Transmit STS-1 Framing Pulse Output pin - Channel 9:</p> <p>See description for Pin # C23 above using the appropriate channel numbers.</p> <p>If STS-3/STM-1 Telecom Bus (associated with STS-3/STM-1 has been enabled - STS-3/STM-1 Receive Telecom Bus - C1/J1 Byte Phase Indicator Output Signal:</p> <p>If STS-3/STM-1 Telecom Bus (associated with STS-3/STM-1 Channel 1) is disabled then the function of this output pin depends upon whether Channel 9 has been configured to in either the DS3/E3 or STS-1 Modes:</p>

STS-3/STM-1 TELECOM BUS INTERFACE - RECEIVE DIRECTION

PIN #	SIGNAL NAME	I/O	SIGNAL TYPE	DESCRIPTION
AC20	STS3RxD_C1J1_2 EG_DS3E3_FP_10 TxSTS1FP_10 RxSBFrame_2	O	CMOS	<p>STS-3/STM-1 Receive Telecom Bus - C1/J1 Byte Phase Indicator Output Signal - Channel 2; Egress Direction DS3/E3 Frame Generator Block Framing Pulse Output pin - Channel 11; Transmit STS-1 Framing Pulse Output pin - Channel 10:</p> <p>See description for Pin # C23 above using the appropriate channel numbers.</p> <p>If STS-3/STM-1 Telecom Bus ((associated with STS-3/STM-1 Channel 2) has been enabled - STS-3/STM-1 Receive Telecom Bus - C1/J1 Byte Phase Indicator Output Signal:</p> <p>If STS-3/STM-1 Telecom Bus ((associated with STS-3/STM-1 Channel 2) is disabled - RxDS3FP_10 (Receive DS3 Frame Pulse Input/Output - Channel 10):</p>
AE14	STS3RxD_C1J1_3 EG_DS3E3_FP_11 TxSTS1FP_11 RxSBFrame_3	O	CMOS	<p>STS-3/STM-1 Receive Telecom Bus - C1/J1 Byte Phase Indicator Output Signal - Channel 3; Egress Direction DS3/E3 Frame Generator Block Framing Pulse Output pin - Channel 11; Transmit STS-1 Framing Pulse Output pin - Channel 11:</p> <p>See description for Pin # C23 above using the appropriate channel numbers.</p> <p>If STS-3/STM-1 Telecom Bus (associated with STS-3/STM-1 Channel 2) is disabled then the function of this output pin depends upon whether Channel 10 has been configured to operate in either the DS3/E3 or STS-1 Modes.:</p> <p>If STS-3/STM-1 Telecom Bus (associated with STS-3/STM-1 Channel 3) is disabled then the function of this output pin depends upon whether Channel 11 has been configured to operate in either the DS3/E3 or STS-1 Modes.</p>

STS-3/STM-1 TELECOM BUS INTERFACE - RECEIVE DIRECTION

PIN #	SIGNAL NAME	I/O	SIGNAL TYPE	DESCRIPTION
C22	STS3RxD_DP_0 EG_DS3E3_FP_4 TxSTS1FP_4	O	CMOS	<p>STS-3/STM-1 Receive (Drop) Telecom Bus - Parity Output Pin - Channel 0; Egress Direction DS3/E3 Frame Generator Block Framing Pulse Output pin - Channel 4; Transmit STS-1 Framing Pulse Output pin - Channel 4:</p> <p>The function of this output pin depends upon whether or not the STS-3/STM-1 Telecom Bus Interface for STS-3/STM-1 Channel 0 has been enabled.</p> <p>If STS-3/STM-1 Telecom Bus (associated with STS-3/STM-1 Channel 0) has been enabled - STS-3/STM-1 Receive Telecom Bus - Parity Output pin:</p> <p>This output pin can be configured to function as one of the following.</p> <ol style="list-style-type: none"> 1. The EVEN or ODD parity value of the bits which are output via the "STS3RXD_D_0[7:0]" output pins. 2. The EVEN or ODD parity value of the bits which are being output via the "STS3RXD_D_0[7:0]" output pins and the states of the "STS3RXD_PL_0" and "STS3RXD_C1J1_0" output pins. <p>This output pin will ultimately be used (by "drop-side" circuitry) to verify the verify of the data which is output via the "STS-3/STM-1 Telecom Bus Interface associated with Channel 0</p> <p>NOTE: <i>The user can make any one of these configuration selections by writing the appropriate value into the "Telecom Bus Control" Register (Direct Address = 0x013B).</i></p> <p>If STS-3/STM-1 Telecom Bus (associated with STS-3/STM-1 Channel 0) is disabled then the function of this output pin depends upon whether Channel 4 has been configured to operate in either the DS3/E3 or STS-1 Modes</p> <p>If Channel 4 is configured to operate in the DS3/E3 Modes - EG_DS3E3_FP_4 (Egress Direction - DS3/E3 Framing Pulse Output pin - Channel 4):</p> <p>If the STS-3/STM-1 Telecom Bus (associated with STS-3/STM-1 Channel 0) is disabled and if Channel 4 is configured to operate in either the DS3 or E3 Modes then this pin will function as the "Egress Direction DS3/E3 Framing Pulse" output pin.</p> <p>In this mode, the Frame Generator block (associated with Channel 4) will pulse this output pin "HIGH" for one DS3/E3 bit-period, coincident with the first bit (within a given DS3 or E3 frame) being output via the "DS3/E3/STS1_Data_OUT_4" output pin.</p> <p>If Channel 4 is configured to operate in the STS-1 Mode - TxSTS1_FP_4 (Transmit Direction - STS-1 Framing Pulse Output pin - Channel 4):</p> <p>If the STS-3/STM-1 Telecom Bus (associated with STS-3/STM-1 Channel 0) is disabled and if Channel 4 is configured to operate in the STS-1/STM-0 Mode, then this pin will function as the "Transmit Direction STS-1 Framing Pulse" output pin.</p> <p>In this mode, the Transmit STS-1 TOH Processor block (associated with Channel 4) will pulse this output pin "HIGH" for one STS-1 bit-period, coincident to whenever the very first bit (within a given STS-1 frame) being output via the "DS3/E3/STS1_DATA_OUT_4" output pin.</p> <p>NOTE: <i>For those applications in which the XRT94L43 is being interfaced to DS3/E3/STS-1 LIU devices, we recommend that the user NOT connect this output pin to any LIU input pin.</i></p>

STS-3/STM-1 TELECOM BUS INTERFACE - RECEIVE DIRECTION

PIN #	SIGNAL NAME	I/O	SIGNAL TYPE	DESCRIPTION
G25	STS3RxD_DP_1 EG_DS3E3_FP_5 TxSTS1FP_5	O	CMOS	<p>STS-3/STM-1 Receive (Drop) Telecom Bus - Parity Output Pin - Channel 1; Egress Direction DS3/E3 Frame Generator Block Framing Pulse Output pin - Channel 5; Transmit STS-1 Framing Pulse Output pin - Channel 5:</p> <p>See description for Pin # C22 above using the appropriate channel numbers.</p> <p>If STS-3/STM-1 Telecom Bus ((associated with STS-3/STM-1 Channel 1) has been enabled - STS-3/STM-1 Receive Telecom Bus - Parity Output pin:</p> <p>If STS-3/STM-1 Telecom Bus (associated with STS-3/STM-1 Channel 1) is disabled then the function of this output pin depends upon whether Channel 5 has been configured to operate in either the DS3/E3 or STS-1 ModesChannel 1) is disabled - RxDS3FP_5 (Receive DS3 Frame Pulse Input/Output - Channel 5):</p>
AC23	STS3RxD_DP_2 EG_DS3E3_FP_6 TxSTS1FP_6	O	CMOS	<p>STS-3/STM-1 Receive (Drop) Telecom Bus - Parity Output Pin - STS-3/STM-1 Channel 2; Egress Direction DS3/E3 Frame Generator Block Framing Pulse Output pin - Channel 6; Transmit STS-1 Framing Pulse Output pin - Channel 6:</p> <p>See description for Pin # C22 above using the appropriate channel numbers.</p> <p>If STS-3/STM-1 Telecom Bus (associated with STS-3/STM-1 Channel 2) has been enabled - STS-3/STM-1 Receive Telecom Bus - Parity Output Pin:</p> <p>If STS-3/STM-1 Telecom Bus (associated with STS-3/STM-1 Channel 2) is disabled then the function of this output pin depends upon whether Channel 2 has been configured to operate in either the DS3/E3 or STS-1 Modes:</p>
AC17	STS3RxD_DP_3 EG_DS3E3_FP_7 TxSTS1FP_7	O	CMOS	<p>STS-3/STM-1 Receive (Drop) Telecom Bus - Parity Output Pin - STS-3/STM-1 Channel 3; Egress Direction DS3/E3 Frame Generator Block Framing Pulse Output pin - Channel 7; Transmit STS-1 Framing Pulse Output pin - Channel 7:</p> <p>See description for Pin # C22 above using the appropriate channel numbers.</p> <p>If STS-3/STM-1 Telecom Bus ((associated with STS-3/STM-1 Channel 3) has been enabled - STS-3/STM-1 Receive Telecom Bus - Parity Output Pin:</p> <p>If STS-3/STM-1 Telecom Bus (associated with STS-3/STM-1 Channel 3) is disabled then the function of this output pin depends upon whether Channel 7 has been configured to operate in either the DS3/E3 or STS-1 Modes:</p>

STS-3/STM-1 TELECOM BUS INTERFACE - RECEIVE DIRECTION

PIN #	SIGNAL NAME	I/O	SIGNAL TYPE	DESCRIPTION
C20	STS3RxD_Alarm_0 EG_DS3E3_FP_0 TxSTS1FP_0	O	CMOS	<p>STS-3/STM-1 Receive (Drop) Telecom Bus - Alarm Indicator Output signal - Channel 0; Egress Direction DS3/E3 Frame Generator Block Framing Pulse Output pin - Channel 0; Transmit STS-1 Framing Pulse Output pin - Channel 0:</p> <p>This output pin pulses "high", coincident with any STS-1 signal (that is being output via the "STS3RXD_D_0[7:0]" output pins) that is carrying an AIS-P indicator.</p> <p>This output pin is "low" for all other conditions.</p> <p>If STS-3/STM-1 Telecom Bus (Channel 0) has been enabled - STS-3/STM-1 Receive Telecom Bus - Alarm Indicator Output signal:</p> <p>This output pin pulses "high", coincident with any STS-1 signal (that is being output via the "STS3RXD_D_0[7:0]" output pins) that is carrying an AIS-P indicator.</p> <p>This output pin is "low" for all other conditions.</p> <p>If STS-3/STM-1 Telecom Bus (Channel 0) is disabled then the function of this output pin depends upon whether Channel 0 has been configured to operate in either the DS3/E3 or STS-1 Modes</p> <p>If Channel 0 is configured to operate in the DS3/E3 Modes - EG_DS3E3_FP_0 (Egress Direction - DS3/E3 Framing Pulse Output pin - Channel 0):</p> <p>If the STS-3/STM-1 Telecom Bus (Channel 0) is disabled and if Channel 0 is configured to operate in either the DS3 or E3 Modes then this pin will function as the "Egress Direction DS3/E3 Framing Pulse" output pin.</p> <p>In this mode, the Frame Generator block (associated with Channel 0) will pulse this output pin "HIGH" for one DS3/E3 bit-period, coincident with the first bit (within a given DS3 or E3 frame) being output via the "DS3/E3/STS1_Data_OUT_0" output pin.</p> <p>If Channel 3 is configured to operate in the STS-1 Mode - TxSTS1_FP_3 (Transmit Direction - STS-1 Framing Pulse Output pin - Channel 3):</p> <p>If the STS-3/STM-1 Telecom Bus (Channel 0) is disabled and if Channel 0 is configured to operate in the STS-1/STM-0 Mode, then this pin will function as the "Transmit Direction STS-1 Framing Pulse" output pin.</p> <p>In this mode, the Transmit STS-1 TOH Processor block (associated with Channel 0) will pulse this output pin "HIGH" for one STS-1 bit-period, coincident to whenever the very first bit (within a given STS-1 frame) being output via the "DS3/E3/STS1_DATA_OUT_0" output pin.</p> <p>NOTE: For those applications in which the XRT94L43 is being interfaced to DS3/E3/STS-1 LIU devices, we recommend that the user NOT connect this output pin to any LIU input pin.</p>
E25	STS3RxD_Alarm_1 RxDS3FP_1 TxSTS1FP_1	O	CMOS	<p>STS-3/STM-1 Receive (Drop) Telecom Bus - Alarm Indicator Output signal - Channel 1; DS3/E3 Frame Synchronizer Framing Pulse Output Pin - Channel 1:</p> <p>See description for Pin # C20 above using the appropriate channel numbers.</p> <p>If STS-3/STM-1 Telecom Bus (Channel 1) has been enabled - STS-3/STM-1 Receive Telecom Bus - Alarm Indicator Output signal:</p> <p>If STS-3/STM-1 Telecom Bus (Channel 1) is disabled then the function of this output pin depends upon whether Channel 1 has been configured to operate in either the DS3/E3 or STS-1 Modes</p>

STS-3/STM-1 TELECOM BUS INTERFACE - RECEIVE DIRECTION

PIN #	SIGNAL NAME	I/O	SIGNAL TYPE	DESCRIPTION
V21	STS3RxD_Alarm_2 RxDS3FP_2 TxSTS1FP_2	O	CMOS	<p>STS-3/STM-1 Receive (Drop) Telecom Bus - Alarm Indicator Output signal - Channel 2; DS3/E3 Frame Synchronizer Framing Pulse Output Pin - Channel 2:</p> <p>See description for Pin # C20 above using the appropriate channel numbers.</p> <p>If STS-3/STM-1 Telecom Bus (Channel 2) has been enabled - STS-3/STM-1 Receive Telecom Bus - Alarm Indicator Output signal:</p> <p>If STS-3/STM-1 Telecom Bus (Channel 2) is disabled then the function of this output pin depends upon whether Channel 1 has been configured to operate in either the DS3/E3 or STS-1 Modes</p>
AD21	STS3RxD_Alarm_3 RxDS3FP_3 TxSTS1FP_3	O	CMOS	<p>STS-3/STM-1 Receive (Drop) Telecom Bus - Alarm Indicator Output signal - Channel 3; DS3/E3 Frame Synchronizer Framing Pulse Output Pin - Channel 1:</p> <p>See description for Pin # C20 above using the appropriate channel numbers.</p> <p>If STS-3/STM-1 Telecom Bus (Channel 3) has been enabled - STS-3/STM-1 Receive Telecom Bus - Alarm Indicator Output signal:</p> <p>If STS-3/STM-1 Telecom Bus (Channel 3) is disabled then the function of this output pin depends upon whether Channel 1 has been configured to operate in either the DS3/E3 or STS-1 Modes</p>
B21	STS3RxD_D_0_0 TxLEV_0 RxSBData_0	O	CMOS	<p>Receive STS-3/STM-1 Telecom Bus - Channel 0 - Output Data Bus Pin Number 0/TxLEV_0 (General Purpose) Output pin:</p> <p>The function of this output pin depends upon whether or not the STS-3/STM-1 Telecom Bus Interface, associated with Channel 0 is enabled.</p> <p>If STS-3/STM-1 Telecom Bus (Channel 0) has been enabled - STS-3/STM-1 Receive Telecom Bus - Output Data bus Pin Number 0: STSRxD_D_0_0:</p> <p>This output pin along with STS3RxD_D_0[7:1] function as the STS-3/STM-1 Receive (Drop) Telecom Bus - Output Data Bus for Channel 0. The STS-3/STM-1 Telecom Bus Interface will update the data via this output upon the rising edge of STS3RxD_CLK_0.</p> <p>NOTE: This input pin functions as the LSB (Least Significant Bit) of the Receive (Drop) Telecom Bus for Channel 0.</p> <p>If STS-3/STM-1 Telecom Bus (Channel 0) is disabled - TXLEV_0 (General Purpose) output Pin.</p> <p>This output pin can be used as a general purpose output pin.</p> <p>The state of this output pin can be controlled by writing the appropriate value into Bit 2 (TxLEV) within the Line Interface Drive Register associated with Channel 0 (Indirect Address = 0x1E, 0x80), (Direct Address = 0x1F80).</p> <p>NOTE: For Product Legacy purposes, this pin is called TxLEV_0 because one possible application is to tie this output pin to a TxLEV (Transmit Line Build-Out Disable) input pin from one of Exar's XRT73L0X/XRT75L0X DS3/E3/STS-1 LIU devices. However, this output pin, and the corresponding register bit can be used for any purpose.</p>

STS-3/STM-1 TELECOM BUS INTERFACE - RECEIVE DIRECTION

PIN #	SIGNAL NAME	I/O	SIGNAL TYPE	DESCRIPTION
B20	STS3RxD_D_0_1 ENCODIS_0 RxSBDData_1	O	CMOS	<p>Receive STS-3/STM-1 Telecom Bus - Channel 0 - Output Data Bus Pin Number 1/ENCODIS_0 (General Purpose) Output Pin:</p> <p>The function of this output pin depends upon whether or not the STS-3/STM-1 Telecom Bus Interface, associated with Channel 0 is enabled.</p> <p>If STS-3/STM-1 Telecom Bus (Channel 0) has been enabled - STS-3/STM-1 Receive Telecom Bus - Output Data bus Pin Number 1: STSRxD_D_0_1:</p> <p>This output pin along with STS3RxD_D_0[7:2] and STS3RxD_D_0_0 function as the STS-3/STM-1 Receive (Drop) Telecom Bus - Output Data Bus for Channel 0. The STS-3/STM-1 Telecom Bus Interface will update the data via this output upon the rising edge of STS3RxD_CLK_0.</p> <p>If STS-3/STM-1 Telecom Bus (Channel 0) is disabled - ENCODIS_0 (General Purpose) output Pin.</p> <p>This output pin can be used as a general purpose output pin.</p> <p>The state of this output pin can be controlled by writing the appropriate value into Bit 3 (ENCODIS) within the Line Interface Drive Register associated with Channel 0 (Indirect Address = 0x1E, 0x80), (Direct Address = 0x1F80).</p> <p>NOTE: For Product Legacy purposes, this pin is called ENCODIS_0 because one possible application is to tie this output pin to an ENCODIS (B3ZS/HDB3 Encoder Disable) input pin from one of Exar's XRT73L0X/XRT75L0X DS3/E3/STS-1 LIU devices. However, this output pin, and the corresponding register bit can be used for any purpose.</p>

STS-3/STM-1 TELECOM BUS INTERFACE - RECEIVE DIRECTION

PIN #	SIGNAL NAME	I/O	SIGNAL TYPE	DESCRIPTION
E20	STS3RxD_D_0_2 DS3/E3/ STS1_Data_OUT_0 RxSBData_2	O	CMOS	<p>Receive STS-3/STM-1 Telecom Bus - Channel 0 - Output Data Bus Pin Number 2/DS3/E3 Framer or Transmit STS-1 TOH Processor block line interface output Pin - Channel 0 (DS3/E3/STS1_DATA_OUT_0):</p> <p>The function of this output pin depends upon whether or not the STS-3/STM-1 Telecom Bus Interface, associated with Channel 0 is enabled.</p> <p>If STS-3/STM-1 Telecom Bus (Channel 0) has been enabled - STS-3/STM-1 Receive Telecom Bus - Output Data bus Pin Number 2: STSRxD_D_0_2:</p> <p>This output pin along with STS3RxD_D_0[7:3] and STS3RxD_D_0[1:0] function as the STS-3/STM-1 Receive (Drop) Telecom Bus - Output Data Bus for Channel 0. The STS-3/STM-1 Telecom Bus Interface will update the data via this output upon the rising edge of STS3RxD_CLK_0.</p> <p>If STS-3/STM-1 Telecom Bus (Channel 0) is disabled - DS3/E3/STS1_DATA_OUT Line Interface Data output Pin - Channel 0:</p> <p>This pin outputs single-rail DS3, E3 or STS-1 data to a DS3/E3/STS-1 LIU IC. This output pin should be connected to the TPOS/TDATA input of the DS3/E3/STS-1 LIU IC (corresponding to Channel 0). By default, the data that is output via this output pin will be updated upon the rising edge of DS3/E3/STS1_CLK_OUT_0 signal pin number C21.</p> <p>For DS3/E3 Applications</p> <p>The XRT94L43 can be configured to update this output signal upon the falling edge of the DS3/E3/STS1_CLK_0 signal by setting Bit 2 (DS3/E3/STS1_CLK_OUT Invert), within the I/O Control Register - Channel 0 (Indirect Address = 0x1E, 0x01), (Direct Address = 0x1F01) to a "1".</p> <p>For STS-1 Applications</p> <p>The XRT94L43 can not be configured to update the DS3/E3/STS1_DATA_OUT_0 signal upon the falling edge of DS3/E3/STS1_CLK_OUT_0.</p>

STS-3/STM-1 TELECOM BUS INTERFACE - RECEIVE DIRECTION

PIN #	SIGNAL NAME	I/O	SIGNAL TYPE	DESCRIPTION
D20	STS3RxD_D_0_3 DS3/E3/ STS1_Data_OUT_4 RxSBData_3	O	CMOS	<p>Receive STS-3/STM-1 Telecom Bus - Channel 0 - Output Data Bus Pin Number 3/DS3/E3 Framers or Transmit STS-1 TOH Processor block line interface output Pin - Channel 4 (DS3/E3/STS1_DATA_OUT_4):</p> <p>The function of this output pin depends upon whether or not the STS-3/STM-1 Telecom Bus Interface, associated with Channel 0 is enabled.</p> <p>If STS-3/STM-1 Telecom Bus (Channel 0) has been enabled - STS-3/STM-1 Receive Telecom Bus - Output Data bus Pin Number 3: STSRxD_D_0_3:</p> <p>This output pin along with STS3RxD_D_0[7:4] and STS3RxD_D_0[2:0] function as the STS-3/STM-1 Receive (Drop) Telecom Bus - Output Data Bus for Channel 0. The STS-3/STM-1 Telecom Bus Interface will update the data via this output upon the rising edge of STS3RxD_CLK_0.</p> <p>If STS-3/STM-1 Telecom Bus (Channel 0) is disabled - DS3/E3/STS1_DATA_OUT Line Interface Data output Pin - Channel 4:</p> <p>This pin outputs single-rail DS3, E3 or STS-1 data to a DS3/E3/STS-1 LIU IC. This output pin should be connected to the TPOS/TDATA input of the DS3/E3/STS-1 LIU IC (corresponding to Channel 4). By default, the data that is output via this output pin will be updated upon the rising edge of the DS3/E3/STS1_CLK_OUT_4 signal pin number E21.</p> <p>For DS3/E3 Applications</p> <p>The XRT94L43 can be configured to update this output signal upon the falling edge of the DS3/E3/STS1_CLK_4 signal by setting Bit 2 (DS3/E3/STS1_CLK_OUT Invert), within the I/O Control Register - Channel 4 (Indirect Address = 0x5E, 0x01), (Direct Address = 0x5F01) to a "1".</p> <p>For STS-1 Applications</p> <p>The XRT94L43 can not be configured to update the DS3/E3/STS1_DATA_OUT_4 signal upon the falling edge of DS3/E3/STS1_CLK_OUT_4.</p>

STS-3/STM-1 TELECOM BUS INTERFACE - RECEIVE DIRECTION

PIN #	SIGNAL NAME	I/O	SIGNAL TYPE	DESCRIPTION
D21	STS3RxD_D_0_4 DS3/E3/ STS1_Data_OUT_8 RxSBData_4	O	CMOS	<p>Receive STS-3/STM-1 Telecom Bus - Channel 0 - Output Data Bus Pin Number 4/DS3/E3 Framer or Transmit STS-1 TOH Processor block line interface output Pin - Channel 8 (DS3/E3/STS1_DATA_OUT_8):</p> <p>The function of this output pin depends upon whether or not the STS-3/STM-1 Telecom Bus Interface, associated with Channel 0 is enabled.</p> <p>If STS-3/STM-1 Telecom Bus (Channel 0) has been enabled - STS-3/STM-1 Receive Telecom Bus - Output Data bus Pin Number 4: STSRxD_D_0_4:</p> <p>This output pin along with STS3RxD_D_0[7:5] and STS3RxD_D_0[3:0] function as the STS-3/STM-1 Receive (Drop) Telecom Bus - Output Data Bus for Channel 0. The STS-3/STM-1 Telecom Bus Interface will update the data via this output upon the rising edge of STS3RxD_CLK_0.</p> <p>If STS-3/STM-1 Telecom Bus (Channel 0) is disabled - DS3/E3/STS1_DATA_OUT Line Interface Data output Pin - Channel 8:</p> <p>This pin outputs single-rail DS3, E3 or STS-1 data to a DS3/E3/STS-1 LIU IC. This output pin should be connected to the TPOS/TDATA input of the DS3/E3/STS-1 LIU IC (corresponding to Channel 8). By default, the data that is being output via this output pin will be updated upon the rising edge of the DS3/E3/STS-1_CLK_OUT_8 signal pin number C24.</p> <p>For DS3/E3 Applications</p> <p>The XRT94L43 can be configured to update the DS3/E3/STS1_DATA_8 output signal upon the falling edge of the DS3/E3/STS1_CLK_8 signal by setting Bit 2 (DS3/E3/STS1_CLK_OUT Invert), within the I/O Control Register - Channel 8 (Indirect Address = 0x9E, 0x01), (Direct Address = 0x9F01) to a "1".</p> <p>For STS-1 Applications</p> <p>The XRT94L43 can not be configured to update the DS3/E3/STS1_DATA_OUT_8 signal upon the falling edge of DS3/E3/STS1_CLK_OUT_8.</p>

STS-3/STM-1 TELECOM BUS INTERFACE - RECEIVE DIRECTION

PIN #	SIGNAL NAME	I/O	SIGNAL TYPE	DESCRIPTION
C21	STS3RxD_D_0_5 DS3/E3/ STS1_Clk_OUT_0 RxSBDData_5	O	CMOS	<p>Receive STS-3/STM-1 Telecom Bus - Channel 0 - Output Data Bus Pin Number 5/DS3/E3 Framer or Transmit STS-1 TOH Processor block line interface clock output Pin - Channel 0: (DS3/E3/STS1_CLK_OUT_0):</p> <p>The function of this output pin depends upon whether or not the STS-3/STM-1 Telecom Bus Interface, associated with Channel 0 is enabled.</p> <p>If STS-3/STM-1 Telecom Bus (Channel 0) has been enabled - STS-3/STM-1 Receive Telecom Bus - Output Data bus Pin Number 5: STSRxD_D_0_5:</p> <p>This output pin along with STS3RxD_D_0[7:6] and STS3RxD_D_0[4:0] function as the STS-3/STM-1 Receive (Drop) Telecom Bus - Output Data Bus for Channel 0. The STS-3/STM-1 Telecom Bus Interface will update the data via this output upon the rising edge of STS3RxD_CLK_0.</p> <p>If STS-3/STM-1 Telecom Bus (Channel 0) is disabled - DS3/E3/STS1_CLK_OUT Line Interface Clock output Pin - Channel 0:</p> <p>This pin outputs a DS3, E3 or STS-1 rate clock signal to a DS3/E3/STS-1 LIU IC. This output pin should be connected to the TxCLK input of the DS3/E3/STS-1 LIU IC (corresponding to Channel 0).</p> <p>By default, the data, which is being output via the DS3/E3/STS1_DATA_OUT_0 output pin will be updated upon the rising edge of this clock output signal.</p> <p>For DS3/E3 Applications</p> <p>The XRT94L43 can be configured to update the DS3/E3/STS1_DATA_0 output signal upon the falling edge of the DS3/E3/STS1_CLK_0 signal by setting Bit 0 (DS3/E3/STS1_CLK_OUT Invert), within the I/O Control Register - Channel 0 (Indirect Address = 0x1E, 0x01), (Direct Address = 0x1F01) to a "1".</p> <p>For STS-1 Applications</p> <p>The XRT94L43 can not be configured to update the DS3/E3/STS1_DATA_OUT_0 signal upon the falling edge of DS3/E3/STS1_CLK_0.</p>

STS-3/STM-1 TELECOM BUS INTERFACE - RECEIVE DIRECTION

PIN #	SIGNAL NAME	I/O	SIGNAL TYPE	DESCRIPTION
E21	STS3RxD_D_0_6 DS3/E3/ STS1_Clk_OUT_4 RxSBData_6	O	CMOS	<p>Receive STS-3/STM-1 Telecom Bus - Channel 0 - Output Data Bus Pin Number 6/DS3/E3 Framer or Transmit STS-1 TOH Processor block line interface clock output Pin - Channel 4: (DS3/E3/STS1_CLK_OUT_4):</p> <p>The function of this output pin depends upon whether or not the STS-3/STM-1 Telecom Bus Interface, associated with Channel 0 is enabled.</p> <p>If STS-3/STM-1 Telecom Bus (Channel 0) has been enabled - STS-3/STM-1 Receive Telecom Bus - Output Data bus Pin Number 6: STSRxD_D_0_6:</p> <p>This output pin along with STS3RxD_D_0_7 and STS3RxD_D_0[5:0] function as the STS-3/STM-1 Receive (Drop) Telecom Bus - Output Data Bus for Channel 0. The STS-3/STM-1 Telecom Bus Interface will update the data via this output upon the rising edge of STS3RxD_CLK_0.</p> <p>If STS-3/STM-1 Telecom Bus (Channel 0) is disabled - DS3/E3/STS1_CLK_OUT Line Interface Clock output Pin - Channel 4:</p> <p>This pin outputs a DS3, E3 or STS-1 rate clock signal to a DS3/E3/STS-1 LIU IC. This output pin should be connected to the TxCLK input of the DS3/E3/STS-1 LIU IC (corresponding to Channel 4).</p> <p>By default, the data, which is being output via the DS3/E3/STS1_DATA_OUT_4 output pin will be updated upon the rising edge of this clock output signal.</p> <p>For DS3/E3 Applications</p> <p>The XRT94L43 can be configured to update the DS3/E3/STS1_DATA_4 output signal upon the falling edge of the DS3/E3/STS1_CLK_4 signal by setting Bit 0 (DS3/E3/STS1_CLK_OUT Invert), within the I/O Control Register - Channel 4 (Indirect Address = 0x5E, 0x01), (Direct Address = 0x5F01) to a "1".</p> <p>For STS-1 Applications</p> <p>The XRT94L43 can not be configured to update the DS3/E3/STS1_DATA_OUT_4 signal upon the falling edge of DS3/E3/STS1_CLK_4.</p>

STS-3/STM-1 TELECOM BUS INTERFACE - RECEIVE DIRECTION

PIN #	SIGNAL NAME	I/O	SIGNAL TYPE	DESCRIPTION
C24	STS3RxD_D_0_7 DS3/E3/ STS1_Clk_OUT_8 RxSBDData_7	O	CMOS	<p>Receive STS-3/STM-1 Telecom Bus - Channel 0 - Output Data Bus Pin Number 7/DS3/E3 Framer or Transmit STS-1 TOH Processor block line interface clock output Pin - Channel 8: (DS3/E3/STS1_CLK_OUT_8):</p> <p>The function of this output pin depends upon whether or not the STS-3/STM-1 Telecom Bus Interface, associated with Channel 0 is enabled.</p> <p>If STS-3/STM-1 Telecom Bus (Channel 0) has been enabled - STS-3/STM-1 Receive Telecom Bus - Output Data bus Pin Number 7: STSRxD_D_0_7:</p> <p>This output pin along with STS3RxD_D_0[6:0] function as the STS-3/STM-1 Receive (Drop) Telecom Bus - Output Data Bus for Channel 0. The STS-3/STM-1 Telecom Bus Interface will update the data via this output upon the rising edge of STS3RxD_CLK_0.</p> <p><i>NOTE: This output pin functions as the MSB (Most Significant Bit) for the STS-3/STM-1 Receive (Drop) Telecom Bus Interface - Output Data Bus (Channel 0).</i></p> <p>If STS-3/STM-1 Telecom Bus (Channel 0) is disabled - DS3/E3/STS1_CLK_OUT Line Interface Clock output Pin - Channel 8:</p> <p>This pin outputs a DS3, E3 or STS-1 rate clock signal to a DS3/E3/STS-1 LIU IC. This output pin should be connected to the TxCLK input of the DS3/E3/STS-1 LIU IC (corresponding to Channel 8).</p> <p>By default, the data, which is being output via the DS3/E3/STS1_DATA_OUT_8 output pin will be updated upon the rising edge of this clock output signal.</p> <p>For DS3/E3 Applications</p> <p>The XRT94L43 can be configured to update the DS3/E3/STS1_DATA_8 output signal upon the falling edge of the DS3/E3/STS1_CLK_8 signal by setting Bit 0 (DS3/E3/STS1_CLK_OUT Invert), within the I/O Control Register - Channel 8 (Indirect Address = 0x9E, 0x01), (Direct Address = 0x9F01) to a "1".</p> <p>For STS-1 Applications</p> <p>The XRT94L43 can not be configured to update the DS3/E3/STS1_DATA_OUT_8 signal upon the falling edge of DS3/E3/STS1_CLK_8.</p>

STS-3/STM-1 TELECOM BUS INTERFACE - RECEIVE DIRECTION

PIN #	SIGNAL NAME	I/O	SIGNAL TYPE	DESCRIPTION
E24	STS3RxD_D_1_0 TxLEV_1 RxSBData_0	O	CMOS	<p>Receive STS-3/STM-1 Telecom Bus - Channel 1 - Output Data Bus Pin Number 0/TxLEV_1 (General Purpose) Output Pin:</p> <p>The function of this output pin depends upon whether or not the STS-3/STM-1 Telecom Bus Interface, associated with Channel 1 is enabled.</p> <p>If STS-3/STM-1 Telecom Bus (Channel 1) has been enabled - STS-3/STM-1 Receive Telecom Bus - Output Data bus Pin Number 0: STSRxD_D_1_0:</p> <p>This output pin along with STS3RxD_D_1[7:1] function as the STS-3/STM-1 Receive (Drop) Telecom Bus - Output Data Bus for Channel 1. The STS-3/STM-1 Telecom Bus Interface will update the data via this output upon the rising edge of STS3RxD_CLK_1.</p> <p><i>NOTE: This input pin functions as the LSB (Least Significant Bit) of the Receive (Drop) Telecom Bus for Channel 1.</i></p> <p>If STS-3/STM-1 Telecom Bus (Channel 1) is disabled - TXLEV_1 (General Purpose) output Pin:</p> <p>This output pin can be used as a general purpose output pin.</p> <p>The state of this output pin can be controlled by writing the appropriate value into Bit 2 (TxLEV) within the Line Interface Drive Register associated with Channel 1 (Indirect Address = 0x2E, 0x80), (Direct Address = 0x2F80).</p> <p><i>NOTE: For Product Legacy purposes, this pin is called TxLEV_1 because one possible application is to tie this output pin to a TxLEV (Transmit Line Build-Out Disable) input pin from one of Exar's XRT73L0X/XRT75L0X DS3/E3/STS-1 LIU devices. However, this output pin, and the corresponding register bit can be used for any purpose.</i></p>
E23	STS3RxD_D_1_1 ENCODIS_1 RxSBData_1	O	CMOS	<p>Receive STS-3/STM-1 Telecom Bus - Channel 1 - Output Data Bus Pin Number 1/ENCODIS_1 (General Purpose) Output Pin:</p> <p>The function of this output pin depends upon whether or not the STS-3/STM-1 Telecom Bus Interface, associated with Channel 1 is enabled.</p> <p>If STS-3/STM-1 Telecom Bus (Channel 1) has been enabled - STS-3/STM-1 Receive Telecom Bus - Output Data bus Pin Number 1: STSRxD_D_1_1:</p> <p>This output pin along with STS3RxD_D_1[7:2] and STS3RxD_D_1_0 function as the STS-3/STM-1 Receive (Drop) Telecom Bus - Output Data Bus for Channel 1. The STS-3/STM-1 Telecom Bus Interface will update the data via this output upon the rising edge of STS3RxD_CLK_1.</p> <p>If STS-3/STM-1 Telecom Bus (Channel 1) is disabled - ENCODIS_1 (General Purpose) output Pin:</p> <p>This output pin can be used as a general purpose output pin.</p> <p>The state of this output pin can be controlled by writing the appropriate value into Bit 3 (ENCODIS) within the Line Interface Drive Register associated with Channel 1 (Indirect Address = 0x2E, 0x80), (Direct Address = 0x2F80).</p> <p><i>NOTE: For Product Legacy purposes, this pin is called ENCODIS_1 because one possible application is to tie this output pin to an ENCODIS (B3ZS/HDB3 Encoder Disable) input pin from one of Exar's XRT73L0X/XRT75L0X DS3/E3/STS-1 LIU devices. However, this output pin, and the corresponding register bit can be used for any purpose.</i></p>

STS-3/STM-1 TELECOM BUS INTERFACE - RECEIVE DIRECTION

PIN #	SIGNAL NAME	I/O	SIGNAL TYPE	DESCRIPTION
F26	STS3RxD_D_1_2 DS3/E3/ STS1_Data_OUT_1 RxSBData_2	O	CMOS	<p>Receive STS-3/STM-1 Telecom Bus - Channel 1 - Output Data Bus Pin Number 2/DS3/E3 Framers or Transmit STS-1 TOH Processor block line interface output Pin - Channel 1 (DS3/E3/STS1_DATA_OUT_1):</p> <p>The function of this output pin depends upon whether or not the STS-3/STM-1 Telecom Bus Interface, associated with Channel 1 is enabled.</p> <p>If STS-3/STM-1 Telecom Bus (Channel 1) has been enabled - STS-3/STM-1 Receive Telecom Bus - Output Data bus Pin Number 2: STSRxD_D_1_2:</p> <p>This output pin along with STS3RxD_D_1[7:3] and STS3RxD_D_1[1:0] function as the STS-3/STM-1 Receive (Drop) Telecom Bus - Output Data Bus for Channel 1. The STS-3/STM-1 Telecom Bus Interface will update the data via this output upon the rising edge of STS3RxD_CLK_1.</p> <p>If STS-3/STM-1 Telecom Bus (Channel 1) is disabled - DS3/E3/STS1_DATA_OUT Line Interface Data output Pin - Channel 1:</p> <p>This pin outputs single-rail DS3, E3 or STS-1 data to a DS3/E3/STS-1 LIU IC. This output pin should be connected to the TPOS/TDATA input of the DS3/E3/STS-1 LIU IC (corresponding to Channel 1). By default, the data that is output via this output pin will be updated upon the rising edge of the DS3/E3/STS1_CLK_OUT_1 signal pin number G26.</p> <p>For DS3/E3 Applications</p> <p>The XRT94L43 can be configured to update this output signal upon the falling edge of the DS3/E3/STS1_CLK_1 signal by setting Bit 2 (DS3/E3/STS1_CLK_OUT Invert), within the I/O Control Register - Channel 1 (Indirect Address = 0x2E, 0x01), (Direct Address = 0x2F01) to a "1".</p> <p>For STS-1 Applications</p> <p>The XRT94L43 can not be configured to update the DS3/E3/STS1_DATA_OUT_1 signal upon the falling edge of DS3/E3/STS1_CLK_OUT_1.</p>

STS-3/STM-1 TELECOM BUS INTERFACE - RECEIVE DIRECTION

PIN #	SIGNAL NAME	I/O	SIGNAL TYPE	DESCRIPTION
H26	STS3RxD_D_1_3 DS3/E3/ STS1_Data_OUT_5 RxSBData_3	O	CMOS	<p>Receive STS-3/STM-1 Telecom Bus - Channel 1 - Output Data Bus Pin Number 3/DS3/E3 Framer or Transmit STS-1 TOH Processor block line interface output Pin - Channel 5 (DS3/E3/STS1_DATA_OUT_5):</p> <p>The function of this output pin depends upon whether or not the STS-3/STM-1 Telecom Bus Interface, associated with Channel 1 is enabled.</p> <p>If STS-3/STM-1 Telecom Bus (Channel 1) has been enabled - STS-3/STM-1 Receive Telecom Bus - Output Data bus Pin Number 3: STSRxD_D_1_3:</p> <p>This output pin along with STS3RxD_D_1[7:4] and STS3RxD_D_1[2:0] function as the STS-3/STM-1 Receive (Drop) Telecom Bus - Output Data Bus for Channel 1. The STS-3/STM-1 Telecom Bus Interface will update the data via this output upon the rising edge of STS3RxD_CLK_1.</p> <p>If STS-3/STM-1 Telecom Bus (Channel 1) is disabled - DS3/E3/STS1_DATA_OUT Line Interface Data output Pin - Channel 5.</p> <p>This pin outputs single-rail DS3, E3 or STS-1 data to a DS3/E3/STS-1 LIU IC. This output pin should be connected to the TPOS/TDATA input of the DS3/E3/STS-1 LIU IC (corresponding to Channel 5). By default, the data that is output via this output pin will be updated upon the rising edge of the DS3/E3/STS1_CLK_OUT_5 signal pin number F25.</p> <p>For DS3/E3 Applications</p> <p>The XRT94L43 can be configured to update this output signal upon the falling edge of the DS3/E3/STS1_CLK_5 signal by setting Bit 2 (DS3/E3/STS1_CLK_OUT Invert), within the I/O Control Register - Channel 5 (Indirect Address = 0x6E, 0x01), (Direct Address = 0x6F01) to a "1".</p> <p>For STS-1 Applications</p> <p>The XRT94L43 can not be configured to update the DS3/E3/STS1_DATA_OUT_5 signal upon the falling edge of DS3/E3/STS1_CLK_OUT_5.</p>

STS-3/STM-1 TELECOM BUS INTERFACE - RECEIVE DIRECTION

PIN #	SIGNAL NAME	I/O	SIGNAL TYPE	DESCRIPTION
J26	STS3RxD_D_1_4 DS3/E3/ STS1_Data_OUT_9 RxSBData_4	O	CMOS	<p>Receive STS-3/STM-1 Telecom Bus - Channel 1 - Output Data Bus Pin Number 4/DS3/E3 Framer or Transmit STS-1 TOH Processor block line interface output Pin - Channel 9 (DS3/E3/STS1_DATA_OUT_9):</p> <p>The function of this output pin depends upon whether or not the STS-3/STM-1 Telecom Bus Interface, associated with Channel 1 is enabled.</p> <p>If STS-3/STM-1 Telecom Bus (Channel 1) has been enabled - STS-3/STM-1 Receive Telecom Bus - Output Data bus Pin Number 4: STSRxD_D_1_4:</p> <p>This output pin along with STS3RxD_D_1[7:5] and STS3RxD_D_1[3:0] function as the STS-3/STM-1 Receive (Drop) Telecom Bus - Output Data Bus for Channel 1. The STS-3/STM-1 Telecom Bus Interface will update the data via this output upon the rising edge of STS3RxD_CLK_1.</p> <p>If STS-3/STM-1 Telecom Bus (Channel 1) is disabled - DS3/E3/STS1_DATA_OUT Line Interface Data output Pin - Channel 9.</p> <p>This pin outputs single-rail DS3, E3 or STS-1 data to a DS3/E3/STS-1 LIU IC. This output pin should be connected to the TPOS/TDATA input of the DS3/E3/STS-1 LIU IC (corresponding to Channel 9). By default, the data that is being output via this output pin will be updated upon the rising edge of the DS3/E3/STS-1_CLK_OUT_9 signal pin number H25.</p> <p>For DS3/E3 Applications</p> <p>The XRT94L43 can be configured to update the DS3/E3/STS1_DATA_9 output signal upon the falling edge of the DS3/E3/STS1_CLK_9 signal by setting Bit 2 (DS3/E3/STS1_CLK_OUT Invert), within the I/O Control Register - Channel 9 (Indirect Address = 0xAE, 0x01), (Direct Address = 0xAF01) to a "1".</p> <p>For STS-1 Applications</p> <p>The XRT94L43 can not be configured to update the DS3/E3/STS1_DATA_OUT_9 signal upon the falling edge of DS3/E3/STS1_CLK_OUT_9.</p>

STS-3/STM-1 TELECOM BUS INTERFACE - RECEIVE DIRECTION

PIN #	SIGNAL NAME	I/O	SIGNAL TYPE	DESCRIPTION
G26	STS3RxD_D_1_5 DS3/E3/ STS1_Clk_OUT_1 RxSBData_5	O	CMOS	<p>Receive STS-3/STM-1 Telecom Bus - Channel 1 - Output Data Bus Pin Number 5/DS3/E3 Framer or Transmit STS-1 TOH Processor block line interface clock output Pin - Channel 1: (DS3/E3/STS1_CLK_OUT_1):</p> <p>The function of this output pin depends upon whether or not the STS-3/STM-1 Telecom Bus Interface, associated with Channel 1 is enabled.</p> <p>If STS-3/STM-1 Telecom Bus (Channel 1) has been enabled - STS-3/STM-1 Receive Telecom Bus - Output Data bus Pin Number 5: STSRxD_D_1_5:</p> <p>This output pin along with STS3RxD_D_1[7:6] and STS3RxD_D_1[4:0] function as the STS-3/STM-1 Receive (Drop) Telecom Bus - Output Data Bus for Channel 1. The STS-3/STM-1 Telecom Bus Interface will update the data via this output upon the rising edge of STS3RxD_CLK_1.</p> <p>If STS-3/STM-1 Telecom Bus (Channel 1) is disabled - DS3/E3/STS1_CLK_OUT Line Interface Clock output Pin - Channel 1:</p> <p>This pin outputs a DS3, E3 or STS-1 rate clock signal to a DS3/E3/STS-1 LIU IC. This output pin should be connected to the TxCLK input of the DS3/E3/STS-1 LIU IC (corresponding to Channel 1).</p> <p>By default, the data, which is being output via the DS3/E3/STS1_DATA_OUT_1 output pin will be updated upon the rising edge of this clock output signal.</p> <p>For DS3/E3 Applications</p> <p>The XRT94L43 can be configured to update the DS3/E3/STS1_DATA_1 output signal upon the falling edge of the DS3/E3/STS1_CLK_1 signal by setting Bit 0 (DS3/E3/STS1_CLK_OUT Invert), within the I/O Control Register - Channel 1 (Indirect Address = 0x2E, 0x01), (Direct Address = 0x2F01) to a "1".</p> <p>For STS-1 Applications</p> <p>The XRT94L43 can not be configured to update the DS3/E3/STS1_DATA_OUT_1 signal upon the falling edge of DS3/E3/STS1_CLK_1.</p>

STS-3/STM-1 TELECOM BUS INTERFACE - RECEIVE DIRECTION

PIN #	SIGNAL NAME	I/O	SIGNAL TYPE	DESCRIPTION
F25	STS3RxD_D_1_6 DS3/E3/ STS1_Clk_OUT_5 RxSBDData_6	O	CMOS	<p>Receive STS-3/STM-1 Telecom Bus - Channel 1 - Output Data Bus Pin Number 6/DS3/E3 Framer or Transmit STS-1 TOH Processor block line interface clock output Pin - Channel 5: (DS3/E3/STS1_CLK_OUT_5):</p> <p>The function of this output pin depends upon whether or not the STS-3/STM-1 Telecom Bus Interface, associated with Channel 1 is enabled.</p> <p>If STS-3/STM-1 Telecom Bus (Channel 1) has been enabled - STS-3/STM-1 Receive Telecom Bus - Output Data bus Pin Number 6: STSRxD_D_1_6:</p> <p>This output pin along with STS3RxD_D_1_7 and STS3RxD_D_1[5:0] function as the STS-3/STM-1 Receive (Drop) Telecom Bus - Output Data Bus for Channel 1. The STS-3/STM-1 Telecom Bus Interface will update the data via this output upon the rising edge of STS3RxD_CLK_1.</p> <p>If STS-3/STM-1 Telecom Bus (Channel 1) is disabled - DS3/E3/STS1_CLK_OUT Line Interface Clock output Pin - Channel 5:</p> <p>This pin outputs a DS3, E3 or STS-1 rate clock signal to a DS3/E3/STS-1 LIU IC. This output pin should be connected to the TxCLK input of the DS3/E3/STS-1 LIU IC (corresponding to Channel 5).</p> <p>By default, the data, which is being output via the DS3/E3/STS1_DATA_OUT_5 output pin will be updated upon the rising edge of this clock output signal.</p> <p>For DS3/E3 Applications</p> <p>The XRT94L43 can be configured to update the DS3/E3/STS1_DATA_5 output signal upon the falling edge of the DS3/E3/STS1_CLK_5 signal by setting Bit 0 (DS3/E3/STS1_CLK_OUT Invert), within the I/O Control Register - Channel 5 (Indirect Address = 0x6E, 0x01), (Direct Address = 0x6F01) to a "1".</p> <p>For STS-1 Applications</p> <p>The XRT94L43 can not be configured to update the DS3/E3/STS1_DATA_OUT_5 signal upon the falling edge of DS3/E3/STS1_CLK_5.</p>

STS-3/STM-1 TELECOM BUS INTERFACE - RECEIVE DIRECTION

PIN #	SIGNAL NAME	I/O	SIGNAL TYPE	DESCRIPTION
H25	STS3RxD_D_1_7 DS3/E3/ STS1_Clk_OUT_9 RxSBData_7	O	CMOS	<p>Receive STS-3/STM-1 Telecom Bus - Channel 1 - Output Data Bus Pin Number 7/DS3/E3 Framer or Transmit STS-1 TOH Processor block line interface clock output Pin - Channel 9: (DS3/E3/STS1_CLK_OUT_9):</p> <p>The function of this output pin depends upon whether or not the STS-3/STM-1 Telecom Bus Interface, associated with Channel 1 is enabled.</p> <p>If STS-3/STM-1 Telecom Bus (Channel 1) has been enabled - STS-3/STM-1 Receive Telecom Bus - Output Data bus Pin Number 7: STSRxD_D_1_7:</p> <p>This output pin along with STS3RxD_D_1[6:0] function as the STS-3/STM-1 Receive (Drop) Telecom Bus - Output Data Bus for Channel 1. The STS-3/STM-1 Telecom Bus Interface will update the data via this output upon the rising edge of STS3RxD_CLK_1.</p> <p><i>NOTE: This output pin functions as the MSB (Most Significant Bit) for the STS-3/STM-1 Receive (Drop) Telecom Bus Interface - Output Data Bus (Channel 1).</i></p> <p>If STS-3/STM-1 Telecom Bus (Channel 1) is disabled - DS3/E3/STS1_CLK_OUT Line Interface Clock output Pin - Channel 9:</p> <p>This pin outputs a DS3, E3 or STS-1 rate clock signal to a DS3/E3/STS-1 LIU IC. This output pin should be connected to the TxCLK input of the DS3/E3/STS-1 LIU IC (corresponding to Channel 9).</p> <p>By default, the data, which is being output via the DS3/E3/STS1_DATA_OUT_9 output pin will be updated upon the rising edge of this clock output pin.</p> <p>For DS3/E3 Applications</p> <p>The XRT94L43 can be configured to update the DS3/E3/STS1_DATA_9 output signal upon the falling edge of the DS3/E3/STS1_CLK_9 signal by setting Bit 0 (DS3/E3/STS1_CLK_OUT Invert), within the I/O Control Register - Channel 9 (Indirect Address = 0xAE, 0x01), (Direct Address = 0xAF01) to a "1".</p> <p>For STS-1 Applications</p> <p>The XRT94L43 can not be configured to update the DS3/E3/STS1_DATA_OUT_9 signal upon the falling edge of DS3/E3/STS1_CLK_9.</p>

STS-3/STM-1 TELECOM BUS INTERFACE - RECEIVE DIRECTION

PIN #	SIGNAL NAME	I/O	SIGNAL TYPE	DESCRIPTION
Y24	STS3RxD_D_2_0 TxLEV_2 RxSBData_0	O	CMOS	<p>Receive STS-3/STM-1 Telecom Bus - Channel 2 - Output Data Bus Pin Number 0/TxLEV_2 (General Purpose) Output Pin:</p> <p>The function of this output pin depends upon whether or not the STS-3/STM-1 Telecom Bus Interface, associated with Channel 2 is enabled.</p> <p>If STS-3/STM-1 Telecom Bus (Channel 2) has been enabled - STS-3/STM-1 Receive Telecom Bus - Output Data bus Pin Number 0: STSRxD_D_2_0:</p> <p>This output pin along with STS3RxD_D_2[7:1] function as the STS-3/STM-1 Receive (Drop) Telecom Bus - Output Data Bus for Channel 2. The STS-3/STM-1 Telecom Bus Interface will update the data via this output upon the rising edge of STS3RxD_CLK_2.</p> <p>NOTE: <i>This input pin functions as the LSB (Least Significant Bit) of the Receive (Drop) Telecom Bus for Channel 2.</i></p> <p>If STS-3/STM-1 Telecom Bus (Channel 2) is disabled - TXLEV_2 (General Purpose) output Pin:</p> <p>This output pin can be used as a general purpose output pin.</p> <p>The state of this output pin can be controlled by writing the appropriate value into Bit 2 (TxLEV) within the Line Interface Drive Register associated with Channel 2 (Indirect Address = 0x3E, 0x80), (Direct Address = 0x3F80).</p> <p>NOTE: <i>For Product Legacy purposes, this pin is called TxLEV_2 because one possible application is to tie this output pin to a TxLEV (Transmit Line Build-Out Disable) input pin from one of Exar's XRT73L0X/XRT75L0X DS3/E3/STS-1 LIU devices. However, this output pin, and the corresponding register bit can be used for any purpose.</i></p>
Y23	STS3RxD_D_2_1 ENCODIS_2 RxSBData_1	O	CMOS	<p>Receive STS-3/STM-1 Telecom Bus - Channel 2 - Output Data Bus Pin Number 1/ENCODIS_2 (General Purpose) Output Pin:</p> <p>The function of this output pin depends upon whether or not the STS-3/STM-1 Telecom Bus Interface, associated with Channel 2 is enabled.</p> <p>If STS-3/STM-1 Telecom Bus (Channel 2) has been enabled - STS-3/STM-1 Receive Telecom Bus - Output Data bus Pin Number 1: STSRxD_D_2_1:</p> <p>This output pin along with STS3RxD_D_2[7:2] and STS3RxD_D_2_0 function as the STS-3/STM-1 Receive (Drop) Telecom Bus - Output Data Bus for Channel 2. The STS-3/STM-1 Telecom Bus Interface will update the data via this output upon the rising edge of STS3RxD_CLK_2.</p> <p>If STS-3/STM-1 Telecom Bus (Channel 2) is disabled - ENCODIS_2 (General Purpose) output Pin:</p> <p>This output pin can be used as a general purpose output pin.</p> <p>The state of this output pin can be controlled by writing the appropriate value into Bit 3 (ENCODIS) within the Line Interface Drive Register associated with Channel 2 (Indirect Address = 0x3E, 0x80), (Direct Address = 0x3F80).</p> <p>NOTE: <i>For Product Legacy purposes, this pin is called ENCODIS_2 because one possible application is to tie this output pin to an ENCODIS (B3ZS/HDB3 Encoder Disable) input pin from one of Exar's XRT73L0X/XRT75L0X DS3/E3/STS-1 LIU devices. However, this output pin, and the corresponding register bit can be used for any purpose.</i></p>

STS-3/STM-1 TELECOM BUS INTERFACE - RECEIVE DIRECTION

PIN #	SIGNAL NAME	I/O	SIGNAL TYPE	DESCRIPTION
W24	STS3RxD_D_2_2 DS3/E3/ STS1_Data_OUT_2 RxSBData_2	O	CMOS	<p>Receive STS-3/STM-1 Telecom Bus - Channel 2 - Output Data Bus Pin Number 2/DS3/E3 Framer or Transmit STS-1 TOH Processor block line interface output Pin - Channel 1 (DS3/E3/STS1_DATA_OUT_2):</p> <p>The function of this output pin depends upon whether or not the STS-3/STM-1 Telecom Bus Interface, associated with Channel 2 is enabled.</p> <p>If STS-3/STM-1 Telecom Bus (Channel 2) has been enabled - STS-3/STM-1 Receive Telecom Bus - Output Data bus Pin Number 2: STSRxD_D_2_2:</p> <p>This output pin along with STS3RxD_D_2[7:3] and STS3RxD_D_2[1:0] function as the STS-3/STM-1 Receive (Drop) Telecom Bus - Output Data Bus for Channel 2. The STS-3/STM-1 Telecom Bus Interface will update the data via this output upon the rising edge of STS3RxD_CLK_2.</p> <p>If STS-3/STM-1 Telecom Bus (Channel 2) is disabled - DS3/E3/STS1_DATA_OUT Line Interface Data output Pin - Channel 2.</p> <p>This pin outputs single-rail DS3, E3 or STS-1 data to a DS3/E3/STS-1 LIU IC. This output pin should be connected to the TPOS/TDATA input of the DS3/E3/STS-1 LIU IC (corresponding to Channel 2). By default, the data that is output via this output pin will be updated upon the rising edge of the DS3/E3/STS1_CLK_OUT_2 signal pin number AC25.</p> <p>For DS3/E3 Applications</p> <p>For DS3/E3 Applications the XRT94L43 can be configured to update this output signal upon the falling edge of the DS3/E3/STS1_CLK_2 signal by setting Bit 2 (DS3/E3/STS1_CLK_OUT Invert), within the I/O Control Register - Channel 2 (Indirect Address = 0x3E, 0x01), (Direct Address = 0x3F01) to a "1".</p> <p>For STS-1 Applications</p> <p>The XRT94L43 can not be configured to update the DS3/E3/STS1_DATA_OUT_2 signal upon the falling edge of DS3/E3/STS1_CLK_OUT_2.</p>

STS-3/STM-1 TELECOM BUS INTERFACE - RECEIVE DIRECTION

PIN #	SIGNAL NAME	I/O	SIGNAL TYPE	DESCRIPTION
AC24	STS3RxD_D_2_3 DS3/E3/ STS1_Data_OUT_6 RxSBData_3	O	CMOS	<p>Receive STS-3/STM-1 Telecom Bus - Channel 2 - Output Data Bus Pin Number 3/DS3/E3 Framer or Transmit STS-1 TOH Processor block line interface output Pin - Channel 6 (DS3/E3/ STS1_DATA_OUT_6):</p> <p>The function of this output pin depends upon whether or not the STS-3/ STM-1 Telecom Bus Interface, associated with Channel 2 is enabled.</p> <p>If STS-3/STM-1 Telecom Bus (Channel 2) has been enabled - STS-3/ STM-1 Receive Telecom Bus - Output Data bus Pin Number 3: STSRxD_D_2_3:</p> <p>This output pin along with STS3RxD_D_2[7:4] and STS3RxD_D_2[2:0] function as the STS-3/STM-1 Receive (Drop) Telecom Bus - Output Data Bus for Channel 2. The STS-3/STM-1 Telecom Bus Interface will update the data via this output upon the rising edge of STS3RxD_CLK_2.</p> <p>If STS-3/STM-1 Telecom Bus (Channel 2) is disabled - DS3/E3/ STS1_DATA_OUT Line Interface Data output Pin - Channel 6.</p> <p>This pin outputs single-rail DS3, E3 or STS-1 data to a DS3/E3/STS-1 LIU IC. This output pin should be connected to the TPOS/TDATA input of the DS3/E3/STS-1 LIU IC (corresponding to Channel 6). By default, the data that is output via this pin will be updated upon the rising edge of the DS3/E3/STS1_CLK_OUT_6 signal pin number AA22.</p> <p>For DS3/E3 Applications</p> <p>The XRT94L43 can be configured to update this output signal upon the falling edge of the DS3/E3/STS1_CLK_6 signal by setting Bit 2 (DS3/E3/ STS1_CLK_OUT Invert), within the I/O Control Register - Channel 6 (Indirect Address = 0x7E, 0x01), (Direct Address = 0x7F01) to a "1".</p> <p>For STS-1 Applications</p> <p>The XRT94L43 can not be configured to update the DS3/E3/ STS1_DATA_OUT_6 signal upon the falling edge of DS3/E3/ STS1_CLK_OUT_6.</p>

STS-3/STM-1 TELECOM BUS INTERFACE - RECEIVE DIRECTION

PIN #	SIGNAL NAME	I/O	SIGNAL TYPE	DESCRIPTION
AC21	STS3RxD_D_2_4 DS3/E3/ STS1_Clk_OUT_10 RxSBData_4	O	CMOS	<p>Receive STS-3/STM-1 Telecom Bus - Channel 2 - Output Data Bus Pin Number 4/DS3/E3 Framer or Transmit STS-1 TOH Processor block line interface output Pin - Channel 10 (DS3/E3/STS1_DATA_OUT_10):</p> <p>The function of this output pin depends upon whether or not the STS-3/STM-1 Telecom Bus Interface, associated with Channel 2 is enabled.</p> <p>If STS-3/STM-1 Telecom Bus (Channel 2) has been enabled - STS-3/STM-1 Receive Telecom Bus - Output Data bus Pin Number 4: STSRxD_D_2_4:</p> <p>This output pin along with STS3RxD_D_2[7:5] and STS3RxD_D_2[3:0] function as the STS-3/STM-1 Receive (Drop) Telecom Bus - Output Data Bus for Channel 2. The STS-3/STM-1 Telecom Bus Interface will update the data via this output upon the rising edge of STS3RxD_CLK_2.</p> <p>If STS-3/STM-1 Telecom Bus (Channel 2) is disabled - DS3/E3/STS1_DATA_OUT Line Interface Data output Pin - Channel 10.</p> <p>This pin outputs single-rail DS3, E3 or STS-1 data to a DS3/E3/STS-1 LIU IC. This output pin should be connected to the TPOS/TDATA input of the DS3/E3/STS-1 LIU IC (corresponding to Channel 10). By default, the data that is being output via the DS3/E3/STS1_DATA_OUT_10 output pin will be updated upon the rising edge of this output clock signal.</p> <p>For DS3/E3 Applications</p> <p>The XRT94L43 can be configured to update the DS3/E3/STS1_DATA_10 output signal upon the falling edge of the DS3/E3/STS1_CLK_10 signal by setting Bit 2 (DS3/E3/STS1_CLK_OUT Invert), within the I/O Control Register - Channel 10 (Indirect Address = 0xBE, 0x01), (Direct Address = 0xBF01) to a "1".</p> <p>For STS-1 Applications</p> <p>The XRT94L43 can not be configured to update the DS3/E3/STS1_DATA_OUT_10 signal upon the falling edge of DS3/E3/STS1_CLK_OUT_10.</p>

STS-3/STM-1 TELECOM BUS INTERFACE - RECEIVE DIRECTION

PIN #	SIGNAL NAME	I/O	SIGNAL TYPE	DESCRIPTION
AC25	STS3RxD_D_2_5 DS3/E3/ STS1_Clk_OUT_2 RxSBDData_5	O	CMOS	<p>Receive STS-3/STM-1 Telecom Bus - Channel 2 - Output Data Bus Pin Number 5/DS3/E3 Framer or Transmit STS-1 TOH Processor block line interface clock output Pin - Channel 2: (DS3/E3/STS1_CLK_OUT_2):</p> <p>The function of this output pin depends upon whether or not the STS-3/STM-1 Telecom Bus Interface, associated with Channel 2 is enabled.</p> <p>If STS-3/STM-1 Telecom Bus (Channel 2) has been enabled - STS-3/STM-1 Receive Telecom Bus - Output Data bus Pin Number 5: STSRxD_D_2_5:</p> <p>This output pin along with STS3RxD_D_2[7:6] and STS3RxD_D_2[4:0] function as the STS-3/STM-1 Receive (Drop) Telecom Bus - Output Data Bus for Channel 2. The STS-3/STM-1 Telecom Bus Interface will update the data via this output upon the rising edge of STS3RxD_CLK_2.</p> <p>If STS-3/STM-1 Telecom Bus (Channel 2) is disabled - DS3/E3/STS1_CLK_OUT Line Interface Clock output Pin - Channel 2:</p> <p>This pin outputs a DS3, E3 or STS-1 rate clock signal to a DS3/E3/STS-1 LIU IC. This output pin should be connected to the TxCLK input of the DS3/E3/STS-1 LIU IC (corresponding to Channel 2).</p> <p>By default, the data, which is being output via the DS3/E3/STS1_DATA_OUT_2 output pin will be updated upon the rising edge of this output clock signal.</p> <p>For DS3/E3 Applications</p> <p>The XRT94L43 can be configured to update the DS3/E3/STS1_DATA_2 output signal upon the falling edge of the DS3/E3/STS1_CLK_2 signal by setting Bit 0 (DS3/E3/STS1_CLK_OUT Invert), within the I/O Control Register - Channel 2 (Indirect Address = 0x3E, 0x01), (Direct Address = 0x3F01) to a "1".</p> <p>For STS-1 Applications</p> <p>The XRT94L43 can not be configured to update the DS3/E3/STS1_DATA_OUT_2 signal upon the falling edge of DS3/E3/STS1_CLK_2.</p>

STS-3/STM-1 TELECOM BUS INTERFACE - RECEIVE DIRECTION

PIN #	SIGNAL NAME	I/O	SIGNAL TYPE	DESCRIPTION
AA22	STS3RxD_D_2_6 DS3/E3/ STS1_Clk_OUT_6 RxSBData_6	O	CMOS	<p>Receive STS-3/STM-1 Telecom Bus - Channel 2 - Output Data Bus Pin Number 6/DS3/E3 Framer or Transmit STS-1 TOH Processor block line interface clock output Pin - Channel 6: (DS3/E3/ STS1_CLK_OUT_6):</p> <p>The function of this output pin depends upon whether or not the STS-3/ STM-1 Telecom Bus Interface, associated with Channel 2 is enabled.</p> <p>If STS-3/STM-1 Telecom Bus (Channel 2) has been enabled - STS-3/ STM-1 Receive Telecom Bus - Output Data bus Pin Number 6: STSRxD_D_2_6:</p> <p>This output pin along with STS3RxD_D_2_7 and STS3RxD_D_2[5:0] function as the STS-3/STM-1 Receive (Drop) Telecom Bus - Output Data Bus for Channel 2. The STS-3/STM-1 Telecom Bus Interface will update the data via this output upon the rising edge of STS3RxD_CLK_2.</p> <p>If STS-3/STM-1 Telecom Bus (Channel 2) is disabled - DS3/E3/ STS1_CLK_OUT Line Interface Clock output Pin - Channel 6:</p> <p>This pin outputs a DS3, E3 or STS-1 rate clock signal to a DS3/E3/STS-1 LIU IC. This output pin should be connected to the TxCLK input of the DS3/E3/STS-1 LIU IC (corresponding to Channel 6).</p> <p>By default, the data, which is being output via the DS3/E3/ STS1_DATA_OUT_6 output pin will be updated upon the rising edge of this output clock signal.</p> <p>For DS3/E3 Applications</p> <p>The XRT94L43 can be configured to update the DS3/E3/STS1_DATA_6 output signal upon the falling edge of the DS3/E3/STS1_CLK_6 signal by setting Bit 0 (DS3/E3/STS1_CLK_OUT Invert), within the I/O Control Register - Channel 6 (Indirect Address = 0x7E, 0x01), (Direct Address = 0x7F01) to a "1".</p> <p>For STS-1 Applications</p> <p>The XRT94L43 can not be configured to update the DS3/E3/ STS1_DATA_OUT_6 signal upon the falling edge of DS3/E3/ STS1_CLK_6.</p>

STS-3/STM-1 TELECOM BUS INTERFACE - RECEIVE DIRECTION

PIN #	SIGNAL NAME	I/O	SIGNAL TYPE	DESCRIPTION
AE23	STS3RxD_D_2_7 DS3/E3/ STS1_Clk_OUT_10 RxSBDData_7	O	CMOS	<p>Receive STS-3/STM-1 Telecom Bus - Channel 2 - Output Data Bus Pin Number 7/DS3/E3 Framer or Transmit STS-1 TOH Processor block line interface clock output Pin - Channel 10: (DS3/E3/ STS1_CLK_OUT_10):</p> <p>The function of this output pin depends upon whether or not the STS-3/ STM-1 Telecom Bus Interface, associated with Channel 2 is enabled.</p> <p>If STS-3/STM-1 Telecom Bus (Channel 2) has been enabled - STS-3/ STM-1 Receive Telecom Bus - Output Data bus Pin Number 7: STSRxD_D_2_7:</p> <p>This output pin along with STS3RxD_D_2[6:0] function as the STS-3/ STM-1 Receive (Drop) Telecom Bus - Output Data Bus for Channel 2. The STS-3/STM-1 Telecom Bus Interface will update the data via this output upon the rising edge of STS3RxD_CLK_2.</p> <p><i>NOTE: This output pin functions as the MSB (Most Significant Bit) for the STS-3/STM-1 Receive (Drop) Telecom Bus Interface - Output Data Bus (Channel 2).</i></p> <p>If STS-3/STM-1 Telecom Bus (Channel 2) is disabled - DS3/E3/ STS1_CLK_OUT Line Interface Clock output Pin - Channel 10:</p> <p>This pin outputs a DS3, E3 or STS-1 rate clock signal to a DS3/E3/STS-1 LIU IC. This output pin should be connected to the TxCLK input of the DS3/E3/STS-1 LIU IC (corresponding to Channel 10).</p> <p>By default, the data, which is being output via the DS3/E3/ STS1_DATA_OUT_10 output pin will be updated upon the rising edge of this output clock signal.</p> <p>For DS3/E3 Applications</p> <p>The XRT94L43 can be configured to update the DS3/E3/STS1_DATA_10 output signal upon the falling edge of the DS3/E3/STS1_CLK_10 signal by setting Bit 0 (DS3/E3/STS1_CLK_OUT Invert), within the I/O Control Register - Channel 10 (Indirect Address = 0xBE, 0x01), (Direct Address = 0xBF01) to a "1".</p> <p>For STS-1 Applications</p> <p>The XRT94L43 can not be configured to update the DS3/E3/ STS1_DATA_OUT_10 signal upon the falling edge of DS3/E3/ STS1_CLK_10.</p>

STS-3/STM-1 TELECOM BUS INTERFACE - RECEIVE DIRECTION

PIN #	SIGNAL NAME	I/O	SIGNAL TYPE	DESCRIPTION
AE21	STS3RxD_D_3_0 TxLEV_3 RxSBData_0	O	CMOS	<p>Receive STS-3/STM-1 Telecom Bus - Channel 3 - Output Data Bus Pin Number 0/TxLEV_3 (General Purpose) Output Pin:</p> <p>The function of this output pin depends upon whether or not the STS-3/STM-1 Telecom Bus Interface, associated with Channel 3 is enabled.</p> <p>If STS-3/STM-1 Telecom Bus (Channel 3) has been enabled - STS-3/STM-1 Receive Telecom Bus - Output Data bus Pin Number 0: STSRxD_D_3_0:</p> <p>This output pin along with STS3RxD_D_3[7:1] function as the STS-3/STM-1 Receive (Drop) Telecom Bus - Output Data Bus for Channel 3. The STS-3/STM-1 Telecom Bus Interface will update the data via this output upon the rising edge of STS3RxD_CLK_3.</p> <p><i>NOTE: This input pin functions as the LSB (Least Significant Bit) of the Receive (Drop) Telecom Bus for Channel 3.</i></p> <p>If STS-3/STM-1 Telecom Bus (Channel 3) is disabled - TXLEV_3 (General Purpose) output Pin:</p> <p>This output pin can be used as a general purpose output pin. The state of this output pin can be controlled by writing the appropriate value into Bit 2 (TxLEV) within the Line Interface Drive Register associated with Channel 3 (Indirect Address = 0x4E, 0x80), (Direct Address = 0x4F80).</p> <p><i>NOTE: For Product Legacy purposes, this pin is called TxLEV_3 because one possible application is to tie this output pin to a TxLEV (Transmit Line Build-Out Disable) input pin from one of Exar's XRT73L0X/XRT75L0X DS3/E3/STS-1 LIU devices. However, this output pin, and the corresponding register bit can be used for any purpose.</i></p>
AC19	STS3RxD_D_3_1 ENCODIS_3 RxSBData_1	O	CMOS	<p>Receive STS-3/STM-1 Telecom Bus - Channel 3 - Output Data Bus Pin Number 1/ENCODIS_3 (General Purpose) Output Pin:</p> <p>The function of this output pin depends upon whether or not the STS-3/STM-1 Telecom Bus Interface, associated with Channel 3 is enabled.</p> <p>If STS-3/STM-1 Telecom Bus (Channel 3) has been enabled - STS-3/STM-1 Receive Telecom Bus - Output Data bus Pin Number 1: STSRxD_D_3_1:</p> <p>This output pin along with STS3RxD_D_3[7:2] and STS3RxD_D_3_0 function as the STS-3/STM-1 Receive (Drop) Telecom Bus - Output Data Bus for Channel 3. The STS-3/STM-1 Telecom Bus Interface will update the data via this output upon the rising edge of STS3RxD_CLK_3.</p> <p>If STS-3/STM-1 Telecom Bus (Channel 3) is disabled - ENCODIS_3 (General Purpose) output Pin:</p> <p>This output pin can be used as a general purpose output pin. The state of this output pin can be controlled by writing the appropriate value into Bit 3 (ENCODIS) within the Line Interface Drive Register associated with Channel 3 (Indirect Address = 0x4E, 0x80), (Direct Address = 0x4F80).</p> <p><i>NOTE: For Product Legacy purposes, this pin is called ENCODIS_3 because one possible application is to tie this output pin to an ENCODIS (B3ZS/HDB3 Encoder Disable) input pin from one of Exar's XRT73L0X/XRT75L0X DS3/E3/STS-1 LIU devices. However, this output pin, and the corresponding register bit can be used for any purpose.</i></p>

STS-3/STM-1 TELECOM BUS INTERFACE - RECEIVE DIRECTION

PIN #	SIGNAL NAME	I/O	SIGNAL TYPE	DESCRIPTION
AB21	STS3RxD_D_3_2 DS3/E3/ STS1_Data_OUT_3 RxSBData_2	O	CMOS	<p>Receive STS-3/STM-1 Telecom Bus - Channel 3 - Output Data Bus Pin Number 2/DS3/E3 Framers or Transmit STS-1 TOH Processor block line interface output Pin - Channel 3 (DS3/E3/STS1_DATA_OUT_3):</p> <p>The function of this output pin depends upon whether or not the STS-3/STM-1 Telecom Bus Interface, associated with Channel 3 is enabled.</p> <p>If STS-3/STM-1 Telecom Bus (Channel 3) has been enabled - STS-3/STM-1 Receive Telecom Bus - Output Data bus Pin Number 2: STSRxD_D_3_2:</p> <p>This output pin along with STS3RxD_D_3[7:3] and STS3RxD_D_3[1:0] function as the STS-3/STM-1 Receive (Drop) Telecom Bus - Output Data Bus for Channel 3. The STS-3/STM-1 Telecom Bus Interface will update the data via this output upon the rising edge of STS3RxD_CLK_3.</p> <p>If STS-3/STM-1 Telecom Bus (Channel 3) is disabled - DS3/E3/STS1_DATA_OUT Line Interface Data output Pin - Channel 3.</p> <p>This pin outputs single-rail DS3, E3 or STS-1 data to a DS3/E3/STS-1 LIU IC. This output pin should be connected to the TPOS/TDATA input of the DS3/E3/STS-1 LIU IC (corresponding to Channel 3). By default, the data that is output via this pin will be updated upon the rising edge of the DS3/E3/STS1_CLK_OUT_3 signal pin number AB20.</p> <p>For DS3/E3 Applications</p> <p>The XRT94L43 can be configured to update this output signal upon the falling edge of the DS3/E3/STS1_CLK_3 signal by setting Bit 2 (DS3/E3/STS1_CLK_OUT Invert), within the I/O Control Register - Channel 3 (Indirect Address = 0x4E, 0x01), (Direct Address = 0x4F01) to a "1".</p> <p>For STS-1 Applications</p> <p>The XRT94L43 can not be configured to update the DS3/E3/STS1_DATA_OUT_3 signal upon the falling edge of DS3/E3/STS1_CLK_OUT_3.</p>

STS-3/STM-1 TELECOM BUS INTERFACE - RECEIVE DIRECTION

PIN #	SIGNAL NAME	I/O	SIGNAL TYPE	DESCRIPTION
AE18	STS3RxD_D_3_3 DS3/E3/ STS1_Data_OUT_7 RxSBData_3	O	CMOS	<p>Receive STS-3/STM-1 Telecom Bus - Channel 3 - Output Data Bus Pin Number 3/DS3/E3 Framer or Transmit STS-1 TOH Processor block line interface output Pin - Channel 7 (DS3/E3/STS1_DATA_OUT_7):</p> <p>The function of this output pin depends upon whether or not the STS-3/STM-1 Telecom Bus Interface, associated with Channel 3 is enabled.</p> <p>If STS-3/STM-1 Telecom Bus (Channel 3) has been enabled - STS-3/STM-1 Receive Telecom Bus - Output Data bus Pin Number 3: STSRxD_D_3_3:</p> <p>This output pin along with STS3RxD_D_3[7:4] and STS3RxD_D_3[2:0] function as the STS-3/STM-1 Receive (Drop) Telecom Bus - Output Data Bus for Channel 3. The STS-3/STM-1 Telecom Bus Interface will update the data via this output upon the rising edge of STS3RxD_CLK_3.</p> <p>If STS-3/STM-1 Telecom Bus (Channel 3) is disabled - DS3/E3/STS1_DATA_OUT Line Interface Data output Pin - Channel 6.</p> <p>This pin outputs single-rail DS3, E3 or STS-1 data to a DS3/E3/STS-1 LIU IC. This output pin should be connected to the TPOS/TDATA input of the DS3/E3/STS-1 LIU IC (corresponding to Channel 7). By default, the data that is output via this pin will be updated upon the rising edge of the DS3/E3/STS1_CLK_OUT_7 signal pin number AD19.</p> <p>For DS3/E3 Applications</p> <p>The XRT94L43 can be configured to update this output signal upon the falling edge of the DS3/E3/STS1_CLK_7 signal by setting Bit 2 (DS3/E3/STS1_CLK_OUT Invert), within the I/O Control Register - Channel 7 (Indirect Address = 0x8E, 0x01), (Direct Address = 0x8F01) to a "1".</p> <p>For STS-1 Applications</p> <p>The XRT94L43 can not be configured to update the DS3/E3/STS1_DATA_OUT_7 signal upon the falling edge of DS3/E3/STS1_CLK_OUT_7.</p>

STS-3/STM-1 TELECOM BUS INTERFACE - RECEIVE DIRECTION

PIN #	SIGNAL NAME	I/O	SIGNAL TYPE	DESCRIPTION
AE15	STS3RxD_D_3_4 DS3/E3/ STS1_Data_OUT_11 RxSBData_4	O	CMOS	<p>Receive STS-3/STM-1 Telecom Bus - Channel 3 - Output Data Bus Pin Number 4/DS3/E3 Framer or Transmit STS-1 TOH Processor block line interface output Pin - Channel 11 (DS3/E3/STS1_DATA_OUT_11):</p> <p>The function of this output pin depends upon whether or not the STS-3/STM-1 Telecom Bus Interface, associated with Channel 3 is enabled.</p> <p>If STS-3/STM-1 Telecom Bus (Channel 3) has been enabled - STS-3/STM-1 Receive Telecom Bus - Output Data bus Pin Number 4: STSRxD_D_3_4:</p> <p>This output pin along with STS3RxD_D_3[7:5] and STS3RxD_D_3[3:0] function as the STS-3/STM-1 Receive (Drop) Telecom Bus - Output Data Bus for Channel 3. The STS-3/STM-1 Telecom Bus Interface will update the data via this output upon the rising edge of STS3RxD_CLK_3.</p> <p>If STS-3/STM-1 Telecom Bus (Channel 3) is disabled - DS3/E3/STS1_DATA_OUT Line Interface Data output Pin - Channel 1.</p> <p>This pin outputs single-rail DS3, E3 or STS-1 data to a DS3/E3/STS-1 LIU IC. This output pin should be connected to the TPOS/TDATA input of the DS3/E3/STS-1 LIU IC (corresponding to Channel 11). By default, the data that is being output via this output pin will be updated upon the rising edge of the DS3/E3/STS-1_CLK_OUT_11 signal pin number AB15.</p> <p>For DS3/E3 Applications</p> <p>The XRT94L43 can be configured to update the DS3/E3/STS1_DATA_11 output signal upon the falling edge of the DS3/E3/STS1_CLK_11 signal by setting Bit 2 (DS3/E3/STS1_CLK_OUT Invert), within the I/O Control Register - Channel 11 (Indirect Address = 0xCE, 0x01), (Direct Address = 0xCF01) to a "1".</p> <p>For STS-1 Applications</p> <p>The XRT94L43 can not be configured to update the DS3/E3/STS1_DATA_OUT_11 signal upon the falling edge of DS3/E3/STS1_CLK_OUT_11.</p>

STS-3/STM-1 TELECOM BUS INTERFACE - RECEIVE DIRECTION

PIN #	SIGNAL NAME	I/O	SIGNAL TYPE	DESCRIPTION
AB20	STS3RxD_D_3_5 DS3/E3/ STS1_Clk_OUT_3 RxSBData_5	O	CMOS	<p>Receive STS-3/STM-1 Telecom Bus - Channel 3 - Output Data Bus Pin Number 5/DS3/E3 Framer or Transmit STS-1 TOH Processor block line interface clock output Pin - Channel 3: (DS3/E3/ STS1_CLK_OUT_3):</p> <p>The function of this output pin depends upon whether or not the STS-3/ STM-1 Telecom Bus Interface, associated with Channel 3 is enabled.</p> <p>If STS-3/STM-1 Telecom Bus (Channel 3) has been enabled - STS-3/ STM-1 Receive Telecom Bus - Output Data bus Pin Number 5: STSRxD_D_3_5:</p> <p>This output pin along with STS3RxD_D_3[7:6] and STS3RxD_D_3[4:0] function as the STS-3/STM-1 Receive (Drop) Telecom Bus - Output Data Bus for Channel 3. The STS-3/STM-1 Telecom Bus Interface will update the data via this output upon the rising edge of STS3RxD_CLK_3.</p> <p>If STS-3/STM-1 Telecom Bus (Channel 3) is disabled - DS3/E3/ STS1_CLK_OUT Line Interface Clock output Pin - Channel 3:</p> <p>This pin outputs a DS3, E3 or STS-1 rate clock signal to a DS3/E3/STS-1 LIU IC. This output pin should be connected to the TxCLK input of the DS3/E3/STS-1 LIU IC (corresponding to Channel 3).</p> <p>By default, the data, which is being output via the DS3/E3/ STS1_DATA_OUT_3 output pin will be updated upon the rising edge of this output pin.</p> <p>For DS3/E3 Applications</p> <p>The XRT94L43 can be configured to update the DS3/E3/STS1_DATA_3 output signal upon the falling edge of the DS3/E3/STS1_CLK_3 signal by setting Bit 0 (DS3/E3/STS1_CLK_OUT Invert), within the I/O Control Register - Channel 3 (Indirect Address = 0x4E, 0x01), (Direct Address = 0x4F01) to a "1".</p> <p>For STS-1 Applications</p> <p>The XRT94L43 can not be configured to update the DS3/E3/ STS1_DATA_OUT_3 signal upon the falling edge of DS3/E3/ STS1_CLK_3.</p>

STS-3/STM-1 TELECOM BUS INTERFACE - RECEIVE DIRECTION

PIN #	SIGNAL NAME	I/O	SIGNAL TYPE	DESCRIPTION
AD19	STS3RxD_D_3_6 DS3/E3/ STS1_Clk_OUT_7 RxSBDData_6	O	CMOS	<p>Receive STS-3/STM-1 Telecom Bus - Channel 3 - Output Data Bus Pin Number 6/DS3/E3 Framer or Transmit STS-1 TOH Processor block line interface clock output Pin - Channel 7: (DS3/E3/STS1_CLK_OUT_7):</p> <p>The function of this output pin depends upon whether or not the STS-3/STM-1 Telecom Bus Interface, associated with Channel 3 is enabled.</p> <p>If STS-3/STM-1 Telecom Bus (Channel 3) has been enabled - STS-3/STM-1 Receive Telecom Bus - Output Data bus Pin Number 6: STSRxD_D_3_6:</p> <p>This output pin along with STS3RxD_D_3_7 and STS3RxD_D_3[5:0] function as the STS-3/STM-1 Receive (Drop) Telecom Bus - Output Data Bus for Channel 3. The STS-3/STM-1 Telecom Bus Interface will update the data via this output upon the rising edge of STS3RxD_CLK_3.</p> <p>If STS-3/STM-1 Telecom Bus (Channel 3) is disabled - DS3/E3/STS1_CLK_OUT Line Interface Clock output Pin - Channel 7:</p> <p>This pin outputs a DS3, E3 or STS-1 rate clock signal to a DS3/E3/STS-1 LIU IC. This output pin should be connected to the TxCLK input of the DS3/E3/STS-1 LIU IC (corresponding to Channel 7).</p> <p>By default, the data, which is being output via the DS3/E3/STS1_DATA_OUT_7 output pin will be updated upon the rising edge of this output pin.</p> <p>For DS3/E3 Applications</p> <p>The XRT94L43 can be configured to update the DS3/E3/STS1_DATA_6 output signal upon the falling edge of the DS3/E3/STS1_CLK_7 signal by setting Bit 0 (DS3/E3/STS1_CLK_OUT Invert), within the I/O Control Register - Channel 7 (Indirect Address = 0x8E, 0x01), (Direct Address = 0x8F01) to a "1".</p> <p>For STS-1 Applications</p> <p>The XRT94L43 can not be configured to update the DS3/E3/STS1_DATA_OUT_7 signal upon the falling edge of DS3/E3/STS1_CLK_7.</p>

STS-3/STM-1 TELECOM BUS INTERFACE - RECEIVE DIRECTION

PIN #	SIGNAL NAME	I/O	SIGNAL TYPE	DESCRIPTION
AB15	STS3RxD_D_3_7 DS3/E3/ STS1_Clk_OUT_11 RxSBData_7	O	CMOS	<p>Receive STS-3/STM-1 Telecom Bus - Channel 3 - Output Data Bus Pin Number 7/DS3/E3 Framer or Transmit STS-1 TOH Processor block line interface clock output Pin - Channel 11: (DS3/E3/STS1_CLK_OUT_11):</p> <p>The function of this output pin depends upon whether or not the STS-3/STM-1 Telecom Bus Interface, associated with Channel 3 is enabled.</p> <p>If STS-3/STM-1 Telecom Bus (Channel 3) has been enabled - STS-3/STM-1 Receive Telecom Bus - Output Data bus Pin Number 7: STSRxD_D_3_7:</p> <p>This output pin along with STS3RxD_D_3[6:0] function as the STS-3/STM-1 Receive (Drop) Telecom Bus - Output Data Bus for Channel 3. The STS-3/STM-1 Telecom Bus Interface will update the data via this output upon the rising edge of STS3RxD_CLK_3.</p> <p><i>NOTE: This output pin functions as the MSB (Most Significant Bit) for the STS-3/STM-1 Receive (Drop) Telecom Bus Interface - Output Data Bus (Channel 3).</i></p> <p>If STS-3/STM-1 Telecom Bus (Channel 3) is disabled - DS3/E3/STS1_CLK_OUT Line Interface Clock output Pin - Channel 11:</p> <p>This pin outputs a DS3, E3 or STS-1 rate clock signal to a DS3/E3/STS-1 LIU IC. This output pin should be connected to the TxCLK input of the DS3/E3/STS-1 LIU IC (corresponding to Channel 11).</p> <p>By default, the data, which is being output via the DS3/E3/STS1_DATA_OUT_11 output pin will be updated upon the rising edge of this clock output signal.</p> <p>For DS3/E3 Applications</p> <p>The XRT94L43 can be configured to update the DS3/E3/STS1_DATA_11 output signal upon the falling edge of the DS3/E3/STS1_CLK_11 signal by setting Bit 0 (DS3/E3/STS1_CLK_OUT Invert), within the I/O Control Register - Channel 11 (Indirect Address = 0xCE, 0x01), (Direct Address = 0xCF01) to a "1".</p> <p>For STS-1 Applications</p> <p>The XRT94L43 can not be configured to update the DS3/E3/STS1_DATA_OUT_11 signal upon the falling edge of DS3/E3/STS1_CLK_11.</p>

RECEIVE TRANSPORT OVERHEAD INTERFACE

PIN #	SIGNAL NAME	I/O	SIGNAL TYPE	DESCRIPTION
Y5	RxTOHClk	O	CMOS	<p>Receive TOH Output Port - Clock Output:</p> <p>This output pin, along with RxTOH, RxTOHValid and RxTOHFrame function as the Receive TOH Output Port:</p> <p>The Receive TOH Output Port is used to obtain the value of the TOH Bytes, within the incoming STS-12/STM-4 signal.</p> <p>This output pin provides a clock signal.</p> <p>If the RxTOHValid output pin is "High", then the contents of the TOH bytes within the incoming STS-12 data-stream, will be serially output via the RxTOH output. This data will be updated upon the falling edge of this clock signal. Therefore, it is advisable to sample the data (at the RxTOH output pin) upon the rising edge of this clock output signal.</p>
W5	RxTOHValid	O	CMOS	<p>Receive TOH Output Port - TOH Valid (or READY) indicator:</p> <p>This output pin, along with RxTOH and RxTOHFrame function as the Receive TOH Output Port.</p> <p>This output pin will toggle "High" whenever valid TOH data is being output via the RxTOH output pin.</p>
V6	RxTOH	O	CMOS	<p>Receive TOH Output port - Output Pin:</p> <p>This output pin, along with RxTOHClk, RxTOHValid and RxTOHFrame function as the Receive TOH Output port.</p> <p>All TOH data, that resides within the incoming STS-12 data-stream will be output via this output pin.</p> <p>The RxTOHValid output pin will toggle "High", coincident with anytime a bit (from the Receive STS-12 TOH data) is being output via this output pin.</p> <p>The RxTOHFrame output pin will pulse "High" (for eight periods of RxTOHClk) coincident to when the A1 byte is being output via this output pin.</p> <p>Data, on this output pin, is updated upon the falling edge of RxTOHClk.</p>
W6	RxTOHFrame	O	CMOS	<p>Receive TOH Output Port - STS-12/STM-4 Frame Indicator:</p> <p>This output pin, along with the RxTOHClk, RxTOHValid and RxTOH output pins function as the Receive TOH Output port.</p> <p>This output pin will pulse "High", for one period of RxTOHClk, one RxTOHClk period prior to the very first TOH bit (of a given STS-12 frame) being output via the RxTOH output pin.</p>
W2	RxLDCCVAL	O	CMOS	<p>Receive - Line DCC Output Port - DCC Value Indicator Output Pin:</p> <p>This output pin, along with the RxTOHClk and the RxLDCC output pins function as the Receive Line DCC output port of the XRT94L43.</p> <p>This output pin pulses "High" coincident to when the Receive Line DCC output port outputs a DCC bit via the RxLDCC output pin.</p> <p>This output pin is updated upon the falling edge of RxTOHClk.</p> <p>The Line DCC HDLC Controller circuitry that is interfaced to this output pin, the RxLDCC and the RxTOHClk pins is suppose to do the following.</p> <ol style="list-style-type: none"> 1. It should continuously sample and monitor the state of this output pin upon the rising edge of RxTOHClk. 2. Anytime the Line DCC HDLC circuitry samples this output pin being "High", it should sample and latch the data on the RxLDCC output pin (as a valid Line DCC bit) into the Line DCC HDLC circuitry.

RECEIVE TRANSPORT OVERHEAD INTERFACE

PIN #	SIGNAL NAME	I/O	SIGNAL TYPE	DESCRIPTION
W3	RxLDCC	O	CMOS	<p>Receive - Line DCC Output Port - Output Pin:</p> <p>This output pin, along with RxLDCCVAL and the RxTOHCik output pins function as the Receive Line DCC output port of the XRT94L43.</p> <p>This pin outputs the contents of the Line DCC (e.g., the D4, D5, D6, D7, D8, D9, D10, D11 and D12 bytes), within the incoming STS-12 data-stream. The Receive Line DCC Output port will assert the RxLDCCVAL output pin, in order to indicate that the data, residing on the RxLDCC output pin is a valid Line DCC byte. The Receive Line DCC output port will update the RxLDCCVAL and the RxLDCC output pins upon the falling edge of the RxTOHCik output pin. The Line DCC HDLC circuitry that is interfaced to this output pin, the RxLDCCVAL and the RxTOHCik pins is suppose to do the following.</p> <ol style="list-style-type: none"> 1. It should continuously sample and monitor the state of the RxLDCCVAL output pin upon the rising edge of RxTOHCik. 2. Anytime the Line DCC HDLC circuitry samples the RxLDCCVAL output pin "High", it should sample and latch the contents of this output pin (as a valid Line DCC bit) into the Line DCC HDLC circuitry.
Y1	RxE1F1E2FP	O	CMOS	<p>Receive - Order-Wire Output Port - Frame Boundary Indicator:</p> <p>This output pin, along with RxE1F1E2, RxE1F1E2Val and the RxTOHCik output pins function as the Receive Order-Wire Output port of the XRT94L43.</p> <p>This output pin pulses "High" (for one period of RxTOHCik) coincident to when the very first bit (of the E1 byte) is being output via the RxE1F1E2 output pin.</p>
Y2	RxE1F1E2	O	CMOS	<p>Receive - Order-Wire Output Port - Output Pin:</p> <p>This output pin, along with RxE1F1E2Val, RxE1F1E2FP, and the RxTOHCik output pins function as the Receive Order-Wire Output Port of the XRT94L43.</p> <p>This pin outputs the contents of the Order-Wire bytes (e.g., the E1, F1 and E2 bytes) within the incoming STS-12 data-stream.</p> <p>The Receive Order-Wire Output port will pulse the RxE1F1E2FP output pin "High" (for one period of RxTOHCik) coincident to when the very first bit (of the E1 byte) is being output via the RxE1F1E2 output pin. Additionally, the Receive Order-Wire Output port will also assert the RxE1F1E2Val output pin, in order to indicate that the data, residing on the RxE1F1E2 output pin is a valid Order-Wire byte.</p> <p>The Receive Order-Wire output port will update the RxE1F1E2Val, the RxE1F1E2FP and the RxE1F1E2 output pins upon the falling edge of the RxTOHCik output pin.</p> <p>The Receive Order-Wire circuitry that is interfaced to this output pin, and the RxE1F1E2Val, the RxE1F1E2 and the RxTOHCik pins is suppose to do the following;</p> <ol style="list-style-type: none"> 1. It should continuously sample and monitor the state of the RxE1F1E2Val and RxE1F1E2FP output pins upon the rising edge of RxTOHCik. 2. Anytime the Order-wire circuitry samples the RxE1F1E2Val and RxE1F1E2FP output pins "High", it should begin to sample and latch the contents of this output pin (as a valid Order-Wire bit) into the Order-Wire circuitry. 3. The Order-Wire circuitry should continue to sample and latch the contents of the output pin until the RxE1F2E2Val output pin is sampled "Low".

RECEIVE TRANSPORT OVERHEAD INTERFACE

PIN #	SIGNAL NAME	I/O	SIGNAL TYPE	DESCRIPTION
AB5	RxSDCC	O	CMOS	<p>Receive - Section DCC Output Port - Output Pin:</p> <p>This output pin, along with RxSDCCVAL and the RxTOHCik output pins function as the Receive Section DCC output port of the XRT94L43.</p> <p>This pin outputs the contents of the Section DCC (e.g., the D1, D2 and D3 bytes), within the incoming STS-12 data-stream. The Receive Section DCC Output port will assert the RxSDCCVAL output pin, in order to indicate that the data, residing on the RxSDCC output pin is a valid Section DCC byte. The Receive Section DCC output port will update the RxSDCCVAL and the RxSDCC output pins upon the falling edge of the RxTOHCik output pin. The Section DCC HDLC circuitry that is interfaced to this output pin, the RxSDCCVAL and the RxTOHCik pins is suppose to do the following.</p> <ol style="list-style-type: none"> 1. It should continuously sample and monitor the state of the RxSDCCVAL output pin upon the rising edge of RxTOHCik. 2. Anytime the Section DCC HDLC circuitry samples the RxSDCCVAL output pin "High", it should sample and latch the contents of this output pin (as a valid Section DCC bit) into the Section DCC HDLC circuitry.
AA5	RxSDCCVAL	O	CMOS	<p>Receive - Section DCC Output Port - DCC Value Indicator Output Pin:</p> <p>This output pin, along with the RxTOHCik and the RxSDCC output pins function as the Receive Section DCC output port of the XRT94L43.</p> <p>This output pin pulses "High" coincident to when the Receive Section DCC output port outputs a DCC bit via the RxSDCC output pin.</p> <p>This output pin is updated upon the falling edge of RxTOHCik.</p> <p>The Section DCC HDLC Controller circuitry that is interfaced to this output pin, the RxSDCC and the RxTOHCik pins is suppose to do the following.</p> <ol style="list-style-type: none"> 1. It should continuously sample and monitor the state of this output pin upon the rising edge of RxTOHCik. 2. Anytime the Section DCC HDLC circuitry samples this output pin being "High", it should sample and latch the data on the RxSDCC output pin (as a valid Section DCC bit) into the Section DCC HDLC circuitry.
W4	RxE1F1E2VAL	O	CMOS	<p>Receive - Order Wire Output Port - E1F1E2 Value Indicator Output Pin:</p> <p>This output pin, along with the RxTOHCik, RxE1F1E2FP, RxE1F1E2 and RxTOHCik output pins function as the Receive - Order Wire Output Port of the XRT94L43.</p> <p>This output pin pulses "High" coincident to when the Receive - Order Wire output port outputs the contents of an E1, F1 or E2 byte, via the RxE1F1E2 output pin.</p> <p>This output pin is updated upon the falling edge of RxTOHCik.</p> <p>The Receive Order-Wire circuitry, that is interfaced to this output pin, the RxE1F1E2 and the RxTOHCik pins is suppose to do the following.</p> <ol style="list-style-type: none"> 1. It should continuously sample and monitor the state of this output pin upon the rising edge of RxTOHCik. 2. Anytime the Receive Order-Wire circuitry samples this output pin being "High", it should sample and latch the data on the RxE1F1E2 output pin (as a valid Order-wire bit) into the Receive Order-Wire circuitry.

RECEIVE TRANSPORT OVERHEAD INTERFACE

PIN #	SIGNAL NAME	I/O	SIGNAL TYPE	DESCRIPTION
B8 B4 AA3 AE3 C6 A1 AB3 AE4 C5 B7 AC3 AF3 A8 A3 Y3 AD3	RxPOH_0 RxPOH_1 RxPOH_2 RxPOH_3 RxPOH_4 RxPOH_5 RxPOH_6 RxPOH_7 RxPOH_8 RxPOH_9 RxPOH_10 RxPOH_11 RxPOH_12 RxPOH_13 RxPOH_14 RxPOH_15	O	CMOS	<p>Receive SONET POH Processor Block - Path Overhead Output Port - Output Pin:</p> <p>These output pins, along with the RxPOHCik_n, RxPOHFrame_n and RxPOHValid_n function as the Receive SONET POH Processor block - POH Output port.</p> <p>These pins serially output the POH data that have been received by each of the Receive SONET POH Processor blocks (via the incoming STS-12 data-stream). Each bit, within the POH bytes is updated (via these output pins) upon the falling edge of RxPOHCik_n. As a consequence, external circuitry receiving this data, should sample this data upon the rising edge of RxPOHCik_n.</p>
B9 B5 AA4 AA8 B6 C4 AB4 AE5 E7 A5 AC4 AB8 A9 D6 Y4 AD4	RxPOHCik_0 RxPOHCik_1 RxPOHCik_2 RxPOHCik_3 RxPOHCik_4 RxPOHCik_5 RxPOHCik_6 RxPOHCik_7 RxPOHCik_8 RxPOHCik_9 RxPOHCik_10 RxPOHCik_11 RxPOHCik_12 RxPOHCik_13 RxPOHCik_14 RxPOHCik_15	O	CMOS	<p>Receive SONET POH Processor Block - Path Overhead Output Port - Clock Output Signal:</p> <p>These output pins, along with RxPOH_n, RxPOHFrame_n and RxPOHValid_n function as the Receive SONET POH Processor block - POH Output Port.</p> <p>These output pins function as the Clock Output signals for the Receive SONET POH Processor block - POH Output Port. The RxPOH_n, RxPOHFrame_n and RxPOHValid_n output pins are updated upon the falling edge of this clock signal. As a consequence, the external circuitry should sample these signals upon the rising edge of this clock signal.</p>

RECEIVE TRANSPORT OVERHEAD INTERFACE

PIN #	SIGNAL NAME	I/O	SIGNAL TYPE	DESCRIPTION
B3	RxPOHFrame_0	O	CMOS	<p>Receive SONET POH Processor Block - Path Overhead Output Port - Frame Boundary Indicator:</p> <p>These output pins, along with the RxPOH_n, RxPOHClk_n and RxPOHValid_n output pins function as the Receive SONET POH Processor Block - Path Overhead Output Port.</p> <p>These output pins will pulse "High" coincident with the very first POH byte (J1), of a given STS-1 frame, is being output via the corresponding RxPOH_n output pin.</p>
C3	RxPOHFrame_1			
AB1	RxPOHFrame_2			
AF1	RxPOHFrame_3			
D4	RxPOHFrame_4			
F7	RxPOHFrame_5			
AC1	RxPOHFrame_6			
AC5	RxPOHFrame_7			
F5	RxPOHFrame_8			
C7	RxPOHFrame_9			
AD1	RxPOHFrame_10			
AD5	RxPOHFrame_11			
F8	RxPOHFrame_12			
E4	RxPOHFrame_13			
AA1	RxPOHFrame_14			
AE1	RxPOHFrame_15			

RECEIVE TRANSPORT OVERHEAD INTERFACE

PIN #	SIGNAL NAME	I/O	SIGNAL TYPE	DESCRIPTION
E6 D3 AB2 AF2 D5 A4 AC2 AC6 A2 C9 AD2 AC7 C8 E5 AA2 AE2	RxPOHValid_0 RxPOHValid_1 RxPOHValid_2 RxPOHValid_3 RxPOHValid_4 RxPOHValid_5 RxPOHValid_6 RxPOHValid_7 RxPOHValid_8 RxPOHValid_9 RxPOHValid_10 RxPOHValid_11 RxPOHValid_12 RxPOHValid_13 RxPOHValid_14 RxPOHValid_15	O	CMOS	<p>Receive SONET POH Processor Block - Path Overhead Output Port - Valid POH Data Indicator:</p> <p>These output pins, along with RxPOH_n, RxPOHClk_n and RxPOHFrame_n function as the Receive SONET POH Processor block - Path Overhead Output port.</p> <p>These output pins will toggle "High" coincident with when valid POH data is being output via the RxPOH_n output pins. This output is updated upon the falling edge of RxPOHClk_n. Hence, external circuitry should sample these signals upon rising edge of RxPOHClk_n.</p>
AA7	LOF 8kHz_OUT	O	CMOS	<p>Receive STS-12 LOF (Loss of Frame) Indicator/8kHz Clock Output:</p> <p>The function of this output pin depends upon whether or not the 8kHz Clock Generation feature has been enabled.</p> <p>8kHz Clock Generation Feature - not enabled (Normal Mode) - The STS-12 Loss of Frame Indicator Output:</p> <p>This output pin indicates whether or not the Receive STS-12 TOH Processor block (within the device) is declaring the LOF condition.</p> <p>"Low" - Indicates that the Receive STS-12 TOH Processor block is NOT currently declaring the LOF condition.</p> <p>"High" - Indicates that the Receive STS-12 TOH Processor block is currently declaring the LOF condition.</p> <p>8kHz Clock Generation Feature - Enabled - 8kHz Clock Output:</p> <p>If this feature is enabled, the XRT94L43 will be configured to derive and generate 8kHz clock output signals, from a particular STS-1 signal that is being received via one of the 12 Receive STS-1 TOH/POH Processor blocks.</p>

GENERAL PURPOSE INPUT/OUTPUT

PIN #	SIGNAL NAME	I/O	SIGNAL TYPE	DESCRIPTION
A19	GPIO_0 ExtLOS_0 SSE_CLK	I/O	TTL/ CMOS	<p>General Purpose Input/Output Pin or External LOS Input Pin/Slow-Speed Interface - Egress - Clock I/O: The function of this input pin depends on whether or not Channel 0 of the DS3/E3 Framer Block is enabled or whether or not the Slow-Speed Interface is enabled.</p> <p>GPIO_0 (DS3/E3 Framer Block - Channel 0 is disabled). If the DS3/E3 Framer Block is disabled, then this pin will function as a General Purpose Input/Output pin. This input pin can be configured to function as either an input or output pin by writing the appropriate value into Bit 0 (GPIO_DIR_0), within the Operation General Purpose Input/Output Direction Register - 0 (Indirect Address = 0x00, 0x4B), (Direct Address = 0x014B). When configured as an input pin, the state of this pin can be monitored by reading the state of Bit 0 (GPIO_0) within the Operation General Purpose Input/Output Register - Byte 0 (Indirect Address = 0x00, 047), (Direct Address = 0x0147). When configured as an output pin, the state of this pin can be controlled by writing the appropriate value into Bit 0 (GPIO_0) within the Operation General Purpose Input/Output Register - Byte 0 (Indirect Address = 0x00, 0x47), (Direct Address = 0x047).</p> <p>ExtLOS_0 (DS3/E3 Framer Block - Channel 0 is enabled). If the DS3/E3 Framer Block is enabled, then this pin will function as the External LOS Input pin for Channel 0. This input pin is intended to be connected to a LOS output pin of a DS3/E3 LIU IC. If this input pin is pulled "High", then the corresponding DS3/E3 Framer block will automatically declare an LOS condition.</p> <p>SSE_CLK (Slow-Speed Interface - Egress Port is enabled): If the Slow-Speed Interface - Egress (SSE) Port is enabled, then this pin will function as either the SSE_CLK output pin or the SSE_CLK input pin. If the user configures the SSE port to operate in the "Insert" Mode, then the SSE port will be configured to replace any "user-selected" Egress DS3/E3 or STS-1 data-stream (within the XRT94L43) with the data that is applied to the SSE_POS and SSE_NEG input pins. More specifically, in the Insert Mode, this pin will function as the SSE_CLK input pin. In this case, the SSE port will sample and latch the contents of the SSE_POS and SSE_NEG input pins upon the falling edge of this input clock signal. If the user configures the SSE port to operate in the "Extract" Mode, then the SSE port will output any "user-selected" Egress DS3/E3 or STS-1 signal (within the XRT94L43) via this output port. More specifically, in the "Extract Mode", this pin will function as the SSE_CLK output pin. In this case, the SSE port will output the data (via the SSE_POS and SSE_NEG output pins) upon the rising edge of this output clock signal.</p>

GENERAL PURPOSE INPUT/OUTPUT

PIN #	SIGNAL NAME	I/O	SIGNAL TYPE	DESCRIPTION
D22	GPIO_1 ExtLOS_1 SSI_CLK	I/O	TTL/ CMOS	<p>General Purpose Input/Output Pin or External LOS Input Pin/Slow-Speed Interface - Ingress - Clock I/O: The function of this input pin depends on whether or not Channel 1 of the DS3/E3 Framer Block is enabled, or whether or not the Slow Speed Interface is enabled.</p> <p>GPIO_1 (DS3/E3 Framer Block - Channel 1 is disabled). If the DS3/E3 Framer Block is disabled, then this pin will function as a General Purpose Input/Output pin. This input pin can be configured to function as either an input or output pin by writing the appropriate value into Bit 1 (GPIO_DIR_1), within the Operation General Purpose Input/Output Direction Register - 0 (Indirect Address = 0x00, 0x4B), (Direct Address = 0x014B). When configured as an input pin, the state of this pin can be monitored by reading the state of Bit 1 (GPIO_1) within the Operation General Purpose Input/Output Register - Byte 0 (Indirect Address = 0x00, 047). When configured as an output pin, the state of this pin can be controlled by writing the appropriate value into Bit 1 (GPIO_1) within the Operation General Purpose Input/Output Register - Byte 0 (Indirect Address = 0x00, 0x47), (Direct Address = 0x0147).</p> <p>ExtLOS_1 (DS3/E3 Framer Block - Channel 1 is enabled), Slow-Speed Interface is Disabled). If the DS3/E3 Framer Block is enabled, then this pin will function as the External LOS Input pin for Channel 1. This input pin is intended to be connected to an LOS output pin of a DS3/E3 LIU IC. If this input pin is pulled "High", then the corresponding DS3/E3 Framer block will automatically declare an LOS condition.</p> <p>SSI_CLK (Slow-Speed Interface - Ingress Port is enabled): If the Slow-Speed Interface -Ingress (SSI) Port is enabled, then this pin will function as either the SSI_CLK output pin or the SSI_CLK input pin. If the user configures the SSI port to operate in the "Insert" Mode, then the SSI port will be configured to replace any "user-selected" Ingress DS3/E3 or STS-1 data-stream (within the XRT94L43) with the data that is applied to the SSI_POS and SSI_NEG input pins. More specifically, in the "Insert" Mode, this pin will function as the "SSI_CLK" input pin. In this case, the SSI port will sample and latch the contents of the SSI_POS and SSI_NEG input pins upon the falling edge of this input clock signal. If the user configures the SSI port to operate in the "Extract" Mode, then the SSI port will output any "user-selected" Ingress DS3/E3 or STS-1 signal (within the XRT94L43) via this output port. More specifically, in the "Extract Mode", this pin will function as the SSI_CLK output pin. In this case, the SSI port will output the data (via the SSI_POS and SSI_NEG output pins) upon the rising edge of this output clock signal.</p>

GENERAL PURPOSE INPUT/OUTPUT

PIN #	SIGNAL NAME	I/O	SIGNAL TYPE	DESCRIPTION
W25	GPIO_2 ExtLOS_2 SSI_POS	I/O	TTL/ CMOS	<p>General Purpose Input/Output Pin or External LOS Input Pin/Slow-Speed Interface -Ingress - Positive Data I/O: The function of this input pin depends on whether or not Channel 2 of the DS3/E3 Framer Block is enabled..</p> <p>GPIO_2 (DS3/E3 Framer Block - Channel 2 is disabled). If the DS3/E3 Framer Block is disabled, then this pin will function as a General Purpose Input/Output pin. This input pin can be configured to function as either an input or output pin by writing the appropriate value into Bit 2 (GPIO_DIR_2), within the Operation General Purpose Input/Output Direction Register - 0 (Indirect Address = 0x00, 0x4B), (Direct Address = 0x014B).</p> <p>When configured as an input pin, the state of this pin can be monitored by reading the state of Bit 2 (GPIO_2) within the Operation General Purpose Input/Output Register - Byte 0 (Indirect Address = 0x00, 047), (Direct Address = 0x0147).</p> <p>When configured as an output pin, the state of this pin can be controlled by writing the appropriate value into Bit 2 (GPIO_2) within the Operation General Purpose Input/Output Register - Byte 0 (Indirect Address = 0x00, 0x47), (Direct Address = 0x0147).</p> <p>ExtLOS_2 (DS3/E3 Framer Block - Channel 2 is enabled, Slow-Speed Interface is Disabled). If the DS3/E3 Framer Block is enabled, then this pin will function as the External LOS Input pin for Channel 2. This input pin is intended to be connected to an LOS output pin of a DS3/E3 LIU IC.</p> <p>If this input pin is pulled "High", then the corresponding DS3/E3 Framer block will automatically declare an LOS condition.</p> <p>SSI_POS (Slow-Speed Interface - Ingress Port is enabled): If the Slow-Speed Interface - Ingress (SSI) Port is enabled, then this pin will function as either the SSI_POS output pin or the SSI_POS input pin. If the user configures the SSI port to operate in the "Insert" Mode, then the SSI port will be configured to replace any "user-selected" Ingress DS3/E3 or STS-1 data-stream (within the XRT94L43) with the data that is applied to the SSI_POS and SSI_NEG input pins. More specifically, in the "Insert" Mode, this pin will function as the SSI_POS input pin. In this case, the SSI port will sample and latch the contents of this input pin (along with SSI_NEG, in a Dual-Rail Manner) upon the falling edge of the SSI_CLK input clock signal.</p> <p>If the user configures the SSI port to operate in the "Extract" Mode, then the SSI port will output any "user-selected" Ingress DS3/E3 or STS-1 signal (within the XRT94L43) via this output port. More specifically, in the "Extract Mode", this pin will function as the SSI_POS output pin. In this case, the SSI port will output data via this pin, along with the SSI_NEG output pin (in a Dual-Rail Manner) upon the rising edge of the SSI_CLK output signal.</p>

GENERAL PURPOSE INPUT/OUTPUT

PIN #	SIGNAL NAME	I/O	SIGNAL TYPE	DESCRIPTION
AC22	GPIO_3 ExtLOS_3 SSE_NEG	I/O	TTL/ CMOS	<p>General Purpose Input/Output Pin or External LOS Input Pin/Slow-Speed Interface - Egress - Negative Data I/O: The function of this input pin depends on whether or not Channel 3 of the DS3/E3 Framer Block is enabled, or whether or not the Slow Speed Interface is enabled.</p> <p>GPIO_3 (DS3/E3 Framer Block - Channel 3 is disabled). If the DS3/E3 Framer Block is disabled, then this pin will function as a General Purpose Input/Output pin. This input pin can be configured to function as either an input or output pin by writing the appropriate value into Bit 3 (GPIO_DIR_3), within the Operation General Purpose Input/Output Direction Register - 0 (Indirect Address = 0x00, 0x4B), (Direct Address = 0x014B). When configured as an input pin, the state of this pin can be monitored by reading the state of Bit 3 (GPIO_3) within the Operation General Purpose Input/Output Register - Byte 0 (Indirect Address = 0x00, 047), (Direct Address = 0x0147). When configured as an output pin, the state of this pin can be controlled by writing the appropriate value into Bit 3 (GPIO_3) within the Operation General Purpose Input/Output Register - Byte 0 (Indirect Address = 0x00, 0x47), (Direct Address = 0x0147).</p> <p>ExtLOS_3 (DS3/E3 Framer Block - Channel 3 is enabled, Slow-Speed Interface is Disabled). If the DS3/E3 Framer Block is enabled, then this pin will function as the External LOS Input pin for Channel 3. This input pin is intended to be connected to an LOS output pin of a DS3/E3 LIU IC. If this input pin is pulled "High", then the corresponding DS3/E3 Framer block will automatically declare an LOS condition.</p> <p>SSE_NEG (Slow-Speed Interface - Egress Port is enabled): If the Slow-Speed Interface - Egress (SSE) Port is enabled, then this pin will function as either the SSE_NEG output pin or the SSE_NEG input pin. If the user configures the SSE port to operate in the "Insert" Mode, then the SSE port will be configured to replace any "user-selected" Egress DS3/E3 or STS-1 data-stream (within the XRT94L43) with the data that is applied to the SSE_POS and SSE_NEG input pins. More specifically, in the "Insert" Mode, this pin will function as the SSE_NEG input pin. In this case, the SSE port will sample and latch the contents of this input pin (along with SSE_POS, in a Dual-Rail Manner) upon the falling edge of the SSE_CLK input clock signal. If the user configures the SSE port to operate in the "Extract" Mode, then the SSE port will output any "user-selected" Egress DS3/E3 or STS-1 signal (within the XRT94L43) via this output port. More specifically, in the "Extract Mode" this pin will function as the SSE_NEG output pin. In this case, the SSE port will output data via this pin, along with the SSE_POS output pin (in a Dual-Rail Manner) upon the rising edge of the SSE_CLK output signal.</p>

CLOCK INPUTS

PIN #	SIGNAL NAME	I/O	SIGNAL TYPE	DESCRIPTION
P23	REFCLK34	I	TTL	E3 Reference Clock Input for the Jitter Attenuator within the DS3/E3 Mapper Block: Apply a signal with a frequency of 34.368±20ppm to this input pin. This input pin functions as the timing reference for the DS3/E3/STS-1 Jitter Attenuator (within the DS3/E3 Mapper block) for E3 applications.
P24	REFCLK51	I	TTL	STS-1 Reference Clock Input for the Jitter Attenuator within the DS3/E3 Mapper Block: The user is expected to apply a signal with a frequency of 51.84MHz±20ppm to this input pin. This input pin functions as the timing reference for the DS3/E3/STS-1 Jitter Attenuator (within the DS3/E3 Mapper block) for STS-1 applications.
P25	REFCLK45	I	TTL	DS3 Reference Clock Input for the Jitter Attenuator within the DS3/E3 Mapper Block: Apply a signal with a frequency of 44.736±20ppm to this input pin. This input pin functions as the timing reference for the DS3/E3/STS-1 Jitter Attenuator (within the DS3/E3 Mapper block) for DS3 applications.

BOUNDARY SCAN

PIN #	SIGNAL NAME	I/O	SIGNAL TYPE	DESCRIPTION
B2	TDO	O		
C2	TDI	I		
B1	TRST	I		
G5	TCK	I		
H6	TMS	I		

MISCELLANEOUS PINS

PIN #	SIGNAL NAME	I/O	SIGNAL TYPE	DESCRIPTION
L21	Test Mode	I		Test Mode Input Pin: Tie this input pin "Low" for normal operation.

POWER SUPPLY PINS

PIN #	SIGNAL NAME	I/O	SIGNAL TYPE	DESCRIPTION
VDD = 3.3V				
N6 N5 P3 R3	Analog VDD Pins (Transmitter)	–		Transmitter Analog Power Supply Voltage = 3.3V Nominal
P4	Analog VDD Pins (PLL)			PLL Analog Power Supply Voltage = 3.3V Nominal
L1	Analog VDD Pins (Receiver)			Receiver Analog Power Supply Voltage = 3.3V Nominal
U6 R15 R16 P15 P16 N15 N16 M15 M16 L15 L16 AA10 AA11 AA9 F10 F11 F9 K21	Digital VDD			Digital Power Supply Voltage = 3.3V Nominal
VDD (2.5V)				
P6 M4 N21 N26 P22	Analog VDD Pins (PLL)			PLL Analog Power Supply Voltage = 2.5 V Nominal
R6	Analog VDD Pins (Transmitter)			Transmitter Analog Power Supply Voltage = 2.5 V Nominal

POWER SUPPLY PINS

PIN #	SIGNAL NAME	I/O	SIGNAL TYPE	DESCRIPTION
L6	Analog VDD Pins (Receiver)			Receiver Analog Power Supply Voltage = 2.5 V Nominal
U21 R11 R12 P11 P12 N11 N12 M11 M12 L11 L12 K6 F16 F17 F18 AA16 AA17 AA18	Digital VDD			Digital Power Supply Voltage = 2.5 V Nominal

GROUND

PIN #	SIGNAL NAME	I/O	SIGNAL TYPE	DESCRIPTION
Y6 Y21 T11 T12 T13 T14 T15 T16 R13 R14 P13 P14 N13 N14 M13 M14 L13 L14 G6 G21 F6 F21 F13 F14 AA6 AA21 AA13 AA14	GND	-		Ground
N3 N4 M3 R5 P5 T6 L2 M6 M21 N24 N25 N22 N23 P21	Analog Ground			
NO CONNECTS				
M23	NC			

GROUND

PIN #	SIGNAL NAME	I/O	SIGNAL TYPE	DESCRIPTION
M26	NC			
T5	NC			

PIN DESCRIPTIONS - INDIRECT ADDRESSING

MICROPROCESSOR INTERFACE

PIN #	SIGNAL NAME	I/O	SIGNAL TYPE	DESCRIPTION
U22	PCLK	I	TTL	Microprocessor Interface Clock Input: This clock input signal is used for synchronous/burst/DMA data transfer operations. This clock can be running up to 66MHz.
L25 L23 L22	PTYPE_0 PTYPE_1 PTYPE_2	I	TTL	Microprocessor Type Select input: These three input pins are used to configure the Microprocessor Interface block to readily support a wide variety of Microprocessor Interfaces. The relationship between the settings of these input pins and the corresponding Microprocessor Interface configuration is presented below. PTYPE[2:0] Microprocessor Interface Mode 000 Asynchronous Intel 1001 Asynchronous Motorola 010 Intel X86 011 Intel I960, Motorola MPC860 100 IDT3051/52 (MIPS) 101 IBM Power PC
V26 R24 P26 M24 T26 M22 M25 L26	PADDR_0 PADDR_1 PADDR_2 PADDR_3 PADDR_4 PADDR_5 PADDR_6 PADDR_7	I	TTL	Address Bus Input pins (Microprocessor Interface): These pins are used to select the on-chip Mapper/Framer registers and RAM space for READ and WRITE Operations with the Microprocessor.
T22 R22 U24 R21 W26 T25 R25 R26	PDATA_0 PDATA_1 PDATA_2 PDATA_3 PDATA_4 PDATA_5 PDATA_6 PDATA_7	I/O	TTL	Bi-Directional Data Bus Pins (Microprocessor Interface): These pins are used to drive and receive data over the bi-directional data bus.
Y26	PWR_L	I	TTL	Write Strobe (Intel Mode): If the Microprocessor Interface is configured to operate in the Intel Mode, then this active-low input pin functions as the WR (WRITE Strobe) input signal from the Microprocessor. Once this active-low signal is asserted, the Mapper/Framer will latch the contents of the bi-directional data (D[7:0]) into the addressed registers (or Buffer location) within the Mapper/Framer. R/W Input Pin (Motorola Mode): When the Microprocessor Interface Section is operating in the Motorola Mode, then this pin is functionally equivalent to the R/W pin. In the Motorola Mode, a READ operation occurs if this pin is at a logic 1. Similarly a WRITE operation occurs if this pin is at a logic 0.

MICROPROCESSOR INTERFACE

PIN #	SIGNAL NAME	I/O	SIGNAL TYPE	DESCRIPTION
T23	PRD_L	I	TTL	<p>READ Strobe (Intel Mode): If the Microprocessor Interface is operating in the Intel Mode, then this input pin will function as the RD* (READ Strobe) input signal from the Microprocessor. Once this active-low signal is asserted, then the Mapper/Framer will place the contents of the addressed register (within the Mapper/Framer IC) on the Microprocessor Bi-directional Data Bus (D[7:0]). When this signal is negated, the Data Bus will be tri-stated.</p> <p>Data Strobe (Motorola Mode): If the Microprocessor Interface is operating in the Motorola Mode, then this input will function as the DS* (Data Strobe) signal.</p>
R23	PAS_L	I	TTL	<p>Address Latch Enable/Address Strobe: This input pin is used to latch the address (present at the Microprocessor Interface Address Bus pins (A[6:0]) into the Mapper/Framer Microprocessor Interface block and to indicate the start of a READ or WRITE cycle. This input pin is active-High, in the Intel Mode and active-Low in the Motorola Mode.</p>
V22	PCS_L	I	TTL	<p>Chip Select Input: This active "Low" signal must be asserted in order to select the Microprocessor Interface for READ and WRITE operations between the Microprocessor and the Mapper/Framer on-chip registers and RAM locations.</p>
Y25	PRDY_L	O	CMOS	<p>READY or DTACK: This active-low output pin will function as the READY output when the Microprocessor Interface is configured to operate in the Intel Mode; and will function as the DTACK output, when the Microprocessor Interface is running in the Motorola Mode.</p> <p>Intel Mode - READY output: When the Mapper/Framer negates this output pin (e.g., toggles it "Low") it indicates (to the Microprocessor) that the current READ or WRITE operation is to be extended until this signal is asserted (e.g., toggled "High").</p> <p>Motorola Mode - DTACK (Data Transfer Acknowledge) Output: The Mapper/Framer will assert this pin in order to inform the Microprocessor that the present READ or WRITE cycle is nearly complete. If the Mapper/Framer requires that the current READ or WRITE cycle be extended, then the Mapper/Framer will delay its assertion of this signal. The 68000 family of Microprocessors require this signal from its peripheral devices, in order to quickly and properly complete a READ or WRITE cycle.</p>
T21	PDBEN_L	I	TTL	<p>Bi-directional Data Bus Enable Input Pin: If the Microprocessor Interface is operating in the Intel-I960 Mode, then this input pin is used to enable the Bi-directional Data Bus. Setting this input pin "Low" enables the Bi-directional Data bus. Setting this input "High" tri-states the Bi-directional Data Bus.</p>

MICROPROCESSOR INTERFACE

PIN #	SIGNAL NAME	I/O	SIGNAL TYPE	DESCRIPTION
U25	PBLAST_L	I	TTL	<p>Last Burst Transfer Indicator input Pin:</p> <p>If the Microprocessor Interface is operating in the Intel-I960 Mode, then this input pin is used to indicate (to the Microprocessor Interface block) that the current data transfer is the last data transfer within the current burst operation.</p> <p>The Microprocessor should assert this input pin (by toggling it "Low") in order to denote that the current READ or WRITE operation (within a BURST operation) is the last operation of this BURST operation.</p>
AC26	PINT_L	O	CMOS	<p>Interrupt Request Output:</p> <p>This open-drain, active-low output signal will be asserted when the Mapper/Framer device is requesting interrupt service from the Microprocessor. This output pin should typically be connected to the Interrupt Request input of the Microprocessor.</p>
L24	RESET_L	I	TTL	<p>Reset Input:</p> <p>When this active-Low signal is asserted, the XRT94L43 will be asynchronously reset. When this occurs, all outputs will be tri-stated and all on-chip registers will be reset to their default values.</p>

SONET/SDH SERIAL LINE INTERFACE PINS

PIN #	SIGNAL NAME	I/O	SIGNAL TYPE	DESCRIPTION
M5	RXL_CLKL_P	I	LVPECL	<p>Receive STS-12/STM-4 Clock - Positive Polarity PECL Input:</p> <p>This input pin, along with RXL_CLKL_N functions as the Recovered Clock Input, from a System back-plane or an Optical Transceiver. The Receive STS-12/STM-4 Interface Block will sample the data, applied at the RXLDATA_P/RXLDATA_N input pins, upon the rising edge of this signal.</p> <p>NOTE: For APS (Automatic Protection Switching) purposes, this input pin, along with RXL_CLKL_N functions as the Primary Receive Clock Input port.</p>
L5	RXL_CLKL_N	I	LVPECL	<p>Receive STS-12/STM-4 Clock - Negative Polarity PECL Input:</p> <p>This input pin, along with RXL_CLKL_P functions as the Recovered Clock Input, from a System back-plane or an Optical Transceiver. The Receiver STS-12/STM-4 Interface Block will sample the data applied at the RXLDATA_P/RXLDATA_N input pins, upon the falling edge of this signal.</p> <p>NOTE: For APS (Automatic Protection Switching) purposes, this input pin, along with RXL_CLKL_P functions as the Primary Receive Clock Input Port.</p>

SONET/SDH OC-12 TO 12XDS3/E3 MAPPER

SONET/SDH SERIAL LINE INTERFACE PINS

PIN #	SIGNAL NAME	I/O	SIGNAL TYPE	DESCRIPTION
K2	RXL_CLKL_R_P	I	LVPECL	<p>Receive STS-12/STM-4 Clock - Positive Polarity PECL Input - Redundant Port:</p> <p>This input pin, along with RXL_CLKL_R_N functions as the Recovered Clock Input, from a System back-plane or an Optical Transceiver. The Receive STS-12/STM-4 Interface Block will sample the data, applied at the RXLDATA_P/RXLDATA_N input pins, upon the rising edge of this signal.</p> <p>NOTE: For APS (Automatic Protection Switching) purposes, this input pin, along with RXL_CLKL_R_N functions as the Redundant Receive Clock Input Port.</p>
K1	RXL_CLKL_R_N	I	LVPECL	<p>Receive STS-12/STM-4 Clock - Negative Polarity PECL Input - Redundant Port:</p> <p>This input pin, along with RXL_CLKL_P functions as the Recovered Clock Input, from a System back-plane or an Optical Transceiver. The Receiver STS-12/STM-4 Interface Block will sample the data applied at the RXLDATA_P/RXLDATA_N input pins, upon the falling edge of this signal.</p> <p>NOTE: For APS (Automatic Protection Switching) purposes, this input pin, along with RXL_CLKL_R_P functions as the Redundant Receive Clock Input Port.</p>
K4	RXL_DATA_P	I	LVPECL	<p>Receive STS-12/STM-4 Data - Positive Polarity PECL Input:</p> <p>This input pin, along with RXL_DATA_N functions as the Recovered Data Input, from a System back-plane or an Optical Transceiver. The Receive STS-12/STM-4 Interface block will sample the data applied to these input pins, upon the rising edge of the RXL_CLKL_P (and the falling edge of the RXL_CLKL_N) signals.</p> <p>NOTE: For APS (Automatic Protection Switching) purposes, this input pin, along with RXL_DATA_N functions as the Primary Receive Data Input Port.</p>
L4	RXL_DATA_N	I	LVPECL	<p>Receive STS-12/STM-4 Data - Negative Polarity PECL Input:</p> <p>This input pin, along with RXL_DATA_P functions as the Recovered Data Input, from a System back-plane or an Optical Transceiver. The Receive STS-12/STM-4 Interface block will sample the data applied to these input pins, upon the rising edge of the RXL_CLKL_P (and the falling edge of the RXL_CLKL_N) signals.</p> <p>NOTE: For APS (Automatic Protection Switching) purposes, this input pin, along with RXL_DATA_P functions as the Primary Receive Data Input Port.</p>
K3	RXL_DATA_R_P	I	LVPECL	<p>Receive STS-12/STM-4 Data - Positive Polarity PECL Input - Redundant Port:</p> <p>This input pin, along with RXL_DATA_R_N functions as the Recovered Data Input, from a System back-plane or an Optical Transceiver. The Receive STS-12/STM-4 Interface block will sample the data applied to these input pins, upon the rising edge of the RXL_CLKL_R_P (and the falling edge of the RXL_CLKL_R_N) signals.</p> <p>NOTE: For APS (Automatic Protection Switching) purposes, this input pin, along with RXL_DATA_R_N functions as the Redundant Receive Data Input Port.</p>

SONET/SDH SERIAL LINE INTERFACE PINS

PIN #	SIGNAL NAME	I/O	SIGNAL TYPE	DESCRIPTION
L3	RXL_DATA_R_N	I	LVPECL	<p>Receive STS-12/STM-4 Data - Negative Polarity PECL Input - Redundant Port:</p> <p>This input pin, along with RXL_DATA_R_P functions as the Recovered Data Input, from a System back-plane or an Optical Transceiver. The Receive STS-12/STM-4 Interface block will sample the data applied to these input pins, upon the rising edge of the RXL_CLKL_R_P (and the falling edge of the RXL_CLKL_R_N) signals.</p> <p>NOTE: For APS (Automatic Protection Switching) purposes, this input pin, along with RXL_DATA_R_N functions as the Redundant Receive Data Input Port.</p>
T3	TXL_CLKI_P	I	LVPECL	<p>Transmit Reference Clock - Positive Polarity PECL Input:</p> <p>This input pin, along with TxL_CLKI_N can be configured to function as the timing source for the STS-12/STM-4 Transmit Interface Block.</p> <p>If these two input pins are configured to function as the timing source, then a 622.08MHz clock signal must be applied to these input pins in the form of a PECL signal. These two inputs can be configured to function as the timing source by writing the appropriate data into the Interface Control Register - Byte 2 (Indirect Address = 0x00, 0x31), (Direct Address = 0x0131).</p>
T4	TXL_CLKI_N	I	LVPECL	<p>Transmit Reference Clock - Negative Polarity PECL Input:</p> <p>This input pin, along with TxL_CLKI_P can be configured to function as the timing source for the STS-12/STM-4 Transmit Interface Block.</p> <p>If these two input pins are configured to function as the timing source, then a 622.08MHz clock signal must be applied to these input pins in the form of a PECL signal. These two inputs can be configured to function as the timing source by writing the appropriate data into the Interface Control Register - Byte 2 (Indirect Address = 0x00, 0x31), (Direct Address = 0x0131).</p>
N1	TXL_DATA_P	O	LVPECL	<p>Transmit STS-12/STM-4 Data - Positive Polarity PECL Output:</p> <p>This output pin, along with TXL_DATA_N functions as the Transmit Data Output, to the System back-plane (for transmission to some other System board) or an Optical Transceiver (for transmission to remote terminal equipment).</p> <p>For High-Speed Back-Plane Applications, it should noted that data is output from these output pins upon the rising/falling edge of TXL_CLKO_P/TXL_CLKO_N).</p> <p>NOTE: For APS (Automatic Protection Switching) purposes, this output pin, along with TXL_DATA_N functions as the Primary Transmit Data Output Port.</p>

SONET/SDH OC-12 TO 12XDS3/E3 MAPPER

SONET/SDH SERIAL LINE INTERFACE PINS

PIN #	SIGNAL NAME	I/O	SIGNAL TYPE	DESCRIPTION
N2	TXL_DATA_N	O	LVPECL	<p>Transmit STS-12/STM-4 Data - Negative Polarity PECL Output:</p> <p>This output pin, along with TXL_DATA_P functions as the Transmit Data Output, to the System back-plane (for transmission to some other System board) or an Optical Transceiver (for transmission to remote terminal equipment).</p> <p>For High-Speed Back-Plane Applications, it should noted that data is output from these output pins upon the rising/falling edge of TXL_CLKO_P/TXL_CLKO_N).</p> <p>NOTE: For APS (Automatic Protection Switching) purposes, this output pin, along with TXL_DATA_P functions as the Primary Transmit Data Output Port.</p>
P1	TXL_DATA_R_P	O	LVPECL	<p>Transmit STS-12/STM-4 Data - Positive Polarity PECL Output - Redundant Port:</p> <p>This output pin, along with TXL_DATA_R_N functions as the Transmit Data Output, to the Optical Transceiver.</p> <p>For High-Speed Back-Plane Applications, it should noted that data is output from these output pins upon the rising/falling edge of TXL_CLKO_R_P/TXL_CLKO_R_N).</p> <p>NOTE: For APS (Automatic Protection Switching) purposes, this output pin, along with TXL_DATA_N functions as the Redundant Receive Data Input Port.</p>
P2	TXL_DATA_R_N	O	LVPECL	<p>Transmit STS-12/STM-4 Data - Negative Polarity PECL Output - Redundant Port:</p> <p>This output pin, along with TXL_DATA_R_P functions as the Transmit Data Output, to the System back-plane (for transmission to some other System board) or an Optical Transceiver (for transmission to remote terminal equipment).</p> <p>For High-Speed Back-Plane Applications, it should noted that data is output from these output pins upon the rising/falling edge of TXL_CLKO_R_P/TXL_CLKO_R_N).</p> <p>NOTE: For APS (Automatic Protection Switching) purposes, this output pin, along with TXL_DATA_R_P functions as the Redundant Transmit Data Output Port.</p>
M1	TXL_CLKO_P	O	LVPECL	<p>Transmit STS-12/STM-4 Clock - Positive Polarity PECL Output:</p> <p>This output pin, along with TXL_CLKO_N functions as the Transmit Clock Output signal. These output pins are typically used in High-Speed Back-Plane Applications. In this case, outbound STS-12/STM-4 data is output via the TXL_DATA_P/TXL_DATA_N output pins upon the rising edge of this clock signal.</p> <p>NOTE: For APS (Automatic Protection Switching) purposes, this output pin, along with TXL_CLKO_N functions as the Primary Transmit Output Clock signal.</p>

SONET/SDH SERIAL LINE INTERFACE PINS

PIN #	SIGNAL NAME	I/O	SIGNAL TYPE	DESCRIPTION
M2	TXL_CLKO_N	O	LVPECL	<p>Transmit STS-12/STM-4 Clock - Negative Polarity PECL Output:</p> <p>This output pin, along with TXLCLKO_P functions as the Transmit Clock Output signal. These output pins are typically used in High-Speed Back-Plane Applications. In this case, outbound STS-12/STM-4 data is output via the TXL_DATA_P/TXL_DATA_N output pins upon the falling edge of this clock signal.</p> <p>NOTE: For APS (Automatic Protection Switching) purposes, this output pin, along with TXL_CLKO_N functions as the Primary Transmit Output Clock signal.</p>
R1	TXL_CLKO_R_P	O	LVPECL	<p>Transmit STS-12/STM-4 Clock - Positive Polarity PECL Output - Redundant Port:</p> <p>This output pin, along with TXL_CLKO_R_N functions as the Transmit Clock Output signal. These output pins are typically used in High-Speed Back-Plane Applications. In this case, outbound STS-12/STM-4 data is output via the TXL_DATA_R_P/TXL_DATA_R_N output pins upon the rising edge of this clock signal.</p> <p>NOTE: For APS (Automatic Protection Switching) purposes, this output pin, along with TXL_CLKO_R_N functions as the Redundant Transmit Output Clock signal.</p>
R2	TXL_CLKO_R_N	O	LVPECL	<p>Transmit STS-12/STM-4 Clock - Negative Polarity PECL Output - Redundant Port:</p> <p>This output pin, along with TXL_CLKO_R_P functions as the Transmit Clock Output signal. These output pins are typically used in High-Speed Back-Plane Applications. In this case, outbound STS-12/STM-4 data is output via the TXL_DATA_R_P/TXL_DATA_R_N output pins upon the rising edge of this clock signal.</p> <p>For APS (Automatic Protection Switching) purposes, this output pin, along with TXL_CLKO_R_P functions as the Redundant Transmit Output Clock signal.</p>

SONET/SDH SERIAL LINE INTERFACE PINS

PIN #	SIGNAL NAME	I/O	SIGNAL TYPE	DESCRIPTION
R4	REFCLK	I	TTL	<p>77.76MHz or 622.08MHz Clock Synthesizer Reference Clock Input Pin:</p> <p>The function of this input pin depends upon whether or not the Transmit STS-12/STM-4 Clock Synthesizer block is enabled.</p> <p>If Clock Synthesizer is Enabled.</p> <p>If the Transmit STS-12/STSM-4 Clock Synthesizer block is to be used to generate the 77.76MHz and/or 622.08MHz clock signal for the STS-12/STM-4 block, then a clock signal of either of the following frequencies, must be applied to this input pin.</p> <ul style="list-style-type: none"> • 12.96MHz • 19.44MHz • 51.84 MHz • 77.76 MHz <p>Afterwards, the appropriate data needs to be written into the Interface Control Register - Byte 2 (Indirect Address = 0x00, 0x31), (Direct Address = 0x0131) in order to;</p> <p>(1) configure the Clock Synthesizer Block to accept any of the above-mentioned signals and generate a 77.76MHz or 622.08MHz clock signal,</p> <p>(2) to configure the Clock Synthesizer to function as the Clock Source for the STS-12/STM-4 block.</p> <p>If Clock Synthesizer is NOT Enabled:</p> <p>If the Transmit STS-12/STSM-4 Clock Synthesizer block is NOT to be used to generate the 77.76MHz and/or 622.08MHz clock signal for the STS-12/STM-4 block, then a 77.76MHz clock signal must be applied to this input pin.</p>
AF6	LOS	I	TTL	<p>Loss of Optical Carrier Input - Primary:</p> <p>The Loss of Carrier output (from the Optical Transceiver) should be connected to this input pin.</p> <p>If this input pin is pulled "High", then the Receive STS-12 TOH Processor block will declare a Loss of Optical Carrier condition.</p> <p>NOTE: <i>This input pin is only active if the Primary Port is active. This input pin is inactive if the Redundant Port is active.</i></p>
AE6	LOS-R	I	TTL	<p>Loss of Optical Carrier Input - Redundant:</p> <p>The Loss of Carrier output (from the Optical Transceiver) should be connected to this input pin.</p> <p>If this input pin is pulled "High", then the Receive STS-12 TOH Processor block will declare a Loss of Optical Carrier condition.</p> <p>NOTE: <i>This input pin is only active if the Redundant Port is active. This input pin is inactive if the Primary Port is active.</i></p>

SONET/SDH SERIAL LINE INTERFACE PINS

PIN #	SIGNAL NAME	I/O	SIGNAL TYPE	DESCRIPTION
AB7	EXSWITCH	O	CMOS	<p>External (APS) Switch Output Pin:</p> <p>This output pin can be used to permit the XRT94L43 to perform APS externally. Specifically, this output pin can be connected to some circuitry that permits the re-direction of STS-12/STM-4 traffic, should an APS event be needed.</p> <p>NOTE: This output pin is disabled if the EXSWITCHDIS input pin number AB6 is pulled "High".</p>
AB6	EXSWITCHDIS	I	TTL	<p>External (APS) Switch Disable:</p> <p>This input pin permits the user to configure the XRT94L43 to perform Line APS Switching internally or externally.</p> <p>0 - Configures the XRT94L43 to perform APS externally. In this mode, the XRT94L43 will execute an APS by toggling the state of the "EXSWITCH" output pin.</p> <p>1 - Configures the XRT94L43 to perform APS internally. In this mode, each of the 12 Receive SONET POH Processor blocks (within the XRT94L43) will internally switch from processing the incoming STS-1 SPE data from the Primary Receive STS-12 TOH Processor block, to now processing the incoming STS-1 SPE data from the Redundant Receive STS-12 TOH Processor block (or vice-versa).</p>

STS-12/STM-4 TELECOM BUS INTERFACE - TRANSMIT DIRECTION

PIN #	SIGNAL NAME	I/O	SIGNAL TYPE	DESCRIPTION
G2	TXA_CLK	O	CMOS	<p>Transmit STS-12/STM-4 Telecom Bus Interface - Clock Signal:</p> <p>This output clock signal functions as the clock source for the STS-12/STM-4 Transmit Telecom Bus. All output signals (on the Transmit STS-12/STM-4 Telecom Bus) are updated upon the rising edge of this clock signal.</p> <p>This clock signal operates at 77.76MHz and is derived from the Transmit Clock Synthesizer block.</p>
J1	TXA_C1J1	O	CMOS	<p>STS-12/STM-4 Transmit Telecom Bus - C1/J1 Byte Phase Indicator Output Signal:</p> <p>This output pin pulses "High" under the following two conditions.</p> <ol style="list-style-type: none"> Whenever the C1 byte is being output via the TxA_D[7:0] output, and Whenever the J1 byte is being output via the TxA_D[7:0] output. <p>NOTES:</p> <ol style="list-style-type: none"> The STS-12/STM-4 Transmit Telecom Bus will indicate that it is transmitting the C1 byte (via the TxA_D[7:0] output pins), by pulsing this output pin "High" (for one period of TXA_CLK) and keeping the TXA_PL output pin pulled "Low". The STS-12/STM-4 Transmit Telecom Bus will indicate that it is transmitting the J1 byte (via the TxA_D[7:0] output pins), by pulsing this output pin "High" (for one period of TXA_CLK) while the TXA_PL output pin is pulled "High". This output pin is only active if the STS-12/STM-4 Telecom Bus is enabled.
J3	TXA_ALARM	O	CMOS	<p>Transmit STS-12/STM-4 Telecom Bus - Alarm Indicator Output signal:</p> <p>This output pin pulses "High", corresponding to any STS-1 signal (that is being output via the TxA_D[7:0] output pins) is carrying the AIS-P indicator.</p> <p>This output pin is "Low" for all other conditions.</p>
H1	TXA_DP	O	CMOS	<p>STS-12/STM-4 Transmit Telecom Bus - Parity Output Pin:</p> <p>This output pin can be configured to function as one of the following.</p> <ol style="list-style-type: none"> The EVEN or ODD parity value of the bits which are output via the TxA_D[7:0] output pins. The EVEN or ODD parity value of the bits which are being output via the TxA_D[7:0] output pins and the states of the TXA_PL and TXA_C1J1 output pins. <p>NOTE: Any one of these configuration selections can be made by writing the appropriate value into the Telecom Bus Control Register (Indirect Address = 0x00, 0x37), (Direct Address = 0x0137)..</p>

STS-12/STM-4 TELECOM BUS INTERFACE - TRANSMIT DIRECTION

PIN #	SIGNAL NAME	I/O	SIGNAL TYPE	DESCRIPTION
K5	TxSBFP	I	TTL	<p>Telecom Bus Sync Reference Input: If either the STS-12/STM-4 or any of the STS-3/STM-1 Telecom Bus Interfaces are enabled, then an 8kHz pulse must be applied to this input pin.</p> <p>If the STS-12/STM-4 Telecom Bus Interface is enabled: The Transmit STS-12/STM-4 Telecom Bus Interface will begin transmitting the very first byte of given STS-12 or STM-4 frame, upon sensing a rising edge (of the 8kHz signal) at this input pin.</p> <p>If any of the STS-3/STM-1 Telecom Bus Interfaces are enabled: The Receive STS-3/STM-1 Telecom Bus Interfaces will begin transmitting the very first byte of a given STS-3 or STM-1 frame, upon sensing a rising edge (of the 8kHz signal) at this input pin.</p> <p>NOTE: <i>If none of the Telecom Bus Interfaces are used, then this pin should be tied to GND.</i></p> <p>NOTES:</p> <ol style="list-style-type: none"> 1. <i>If this input pin is tied to GND, then the Transmit STS-12 TOH Processor block will generate its outbound STS-12/STM-4 frames asynchronously with respect to any input signal.</i> 2. <i>This input signal must be synchronized with the signal that is supplied to the REFCLK input pin. Failure to insure this will result in bit errors being generated within the outbound STS-12/STM-4 signal.</i> 3. <i>An 8kHz pulse must be applied to this input pin, that has a width of approximately 12.8ns (one 77.76MHz clock period). Do not apply a 50% duty cycle 8kHz signal to this input pin.</i>

STS-12/STM-4 TELECOM BUS INTERFACE - TRANSMIT DIRECTION

PIN #	SIGNAL NAME	I/O	SIGNAL TYPE	DESCRIPTION
F3	TxA_PL	O	CMOS	<p>STS-12/STM-4 Transmit Telecom Bus - Payload Data Indicator Signal:</p> <p>This output pin indicates whether or not TOH Transport Overhead bytes are being output via the TXA_D[7:0] output pins.</p> <p>This output pin is pulled "Low" for the duration that the STS-12/STM-4 Transmit Telecom Bus is transmitting a Transport Overhead byte via the TXA_D[7:0] output pins.</p> <p>Conversely, this output pin is pulled "High" for the duration that the STS-12/STM-4 Transmit Telecom Bus is transmitting something other than a Transport Overhead byte (e.g., the POH or STS-1/STS-3c SPE bytes) via the TXA_D[7:0] output pins.</p>
G1 J5 J2 H5 E1 F2 F1 E3	TxA_D0 TxA_D1 TxA_D2 TxA_D3 TxA_D4 TxA_D5 TxA_D6 TxA_D7	O	CMOS	<p>STS-12/STM-4 Transmit Telecom Bus - Transmit Output Data Bus pins:</p> <p>These 8 output pins function as the "STS-12/STM-4 Transmit Telecom Bus" Transmit Output data bus. If the STS-12/STM-4 Telecom Bus Interface is enabled, then all STS-12/STM-4 data is output via these pins (in a byte-wide manner), upon the rising edge of the "TXA_CLK" output pin.</p> <p>NOTES:</p> <ol style="list-style-type: none"> 1. The pin TXA_D7 will output the MSB (Most Significant Bit) of each byte that is output via the Transmit STS-12/STM-4 Telecom Bus Interface. 2. The pin TXA_D0 will output the LSB (Least Significant Bit) of each byte that is output via the Transmit STS-12/STM-4 Telecom Bus Interface.

STS-12/STM-4 TELECOM BUS INTERFACE - RECEIVE DIRECTION

PIN #	SIGNAL NAME	I/O	SIGNAL TYPE	DESCRIPTION
V4	RxD_CLK	I	TTL	<p>Receive STS-12/STM-4 Telecom Bus Interface - Clock Signal:</p> <p>This input clock signal functions as the clock source for the Receive STS-12/STM-4 Telecom Bus Interface. All Receive STS-12/STM-4 Telecom Bus Interface signals are sampled upon the rising edge of this input clock signal.</p> <p>This clock signal should operate at 77.76MHz.</p> <p>NOTE: This input pin is only used if the STS-12/STM-4 Telecom Bus has been enabled. It should be tied to GND otherwise.</p>
U5	RxD_PL	I	TTL	<p>Receive STS-12/STM-4 Telecom Bus Interface - Payload Indicator Signal:</p> <p>This input pin indicates whether or not STS-1/STS-3c SPE bytes are being input via the RXD_D[7:0] input pins.</p> <p>This input pin should be pulled "High" coincident to whenever the Receive STS-12/STM-4 Telecom Bus Interface block is receiving STS-1/STS-3c SPE data bytes via the RXD_D[7:0] input pins.</p> <p>Conversely, this input pin should be pulled "low" coincident to whenever the Receive STS-12/STM-4 Telecom Bus Interface block is receiving something other than an STS-1/STS-3c SPE byte (e.g., a TOH byte) via the RXD_D[7:0] input pins.</p> <p>NOTE: The user should tie this pin to GND if the STS-12/STM-4 Telecom Bus Interface is configured to operate in the Re-Phase ON Mode or is disabled. Tie this pin to GND if the STS-12/STM-4 Telecom Bus is NOT enabled.</p>
V2	RxD_C1J1	I	TTL	<p>STS-12/STM-4 Receive Telecom Bus C1/J1 Byte Phase Indicator Input Signal:</p> <p>This input pin should be pulsed "High" during both of the following conditions.</p> <ol style="list-style-type: none"> 1. Whenever the C1 byte is being input to the Receive STS-12/STM-4 Telecom Bus Interface - Data Bus Input pins (RXD_D[7:0]). 2. Whenever the J1 byte is being input to the Receive STS-12/STM-4 Telecom Bus Interface - DataBus Input pins (RXD_D[7:0]). <p>This input pin should be pulled "low" for all other times.</p> <p>NOTE: Tie this pin to GND if the STS-12/STM-4 Telecom Bus is NOT enabled.</p>

STS-12/STM-4 TELECOM BUS INTERFACE - RECEIVE DIRECTION

PIN #	SIGNAL NAME	I/O	SIGNAL TYPE	DESCRIPTION
U4	RxD_DP	I	TTL	<p>STS-12/STM-4 Receive Telecom Bus - Parity Input Pin:</p> <p>This input pin can be configured to function as one of the following.</p> <ol style="list-style-type: none"> The EVEN or ODD parity value of the bits which are input via the RxD_D[7:0] input pins. The EVEN or ODD parity value of the bits which are being input via the RxD_D[7:0] input and the states of the RxD_PL and RxD_C1J1 input pins. <p>The Receive STS-12/STM-4 Telecom Bus Interface will use this pin to compute and verify the parity within the incoming STS-12/STM-4 data-stream.</p> <p>NOTES:</p> <ol style="list-style-type: none"> Any one of these configuration selections can be made by writing the appropriate value into the Telecom Bus Control register (Indirect Address = 0x00, 0x37, direct Address = 0x0137). Tie this pin to GND if the STS-12/STM-4 Telecom Bus Interface is configured to operate in the Re-Phase ON Mode or is disabled.
T2	RxD_ALARM	I	TTL	<p>Receive STS-12/STM-4 Telecom Bus - Alarm Indicator Input:</p> <p>This input pin pulses "High" corresponding to any STS-1 signal that is carrying the AIS-P indicator.</p> <p>More specifically, this input pin will be pulsed "High" coincident to whenever a byte, corresponding to given STS-1 signal (that is carrying the AIS-P indicator) is being placed on the Receive STS-12/STM-4 Telecom Bus - Data Bus Input pins (RxD_D[7:0]). This input pin should be pulled "Low" at all other times.</p> <p>NOTES:</p> <ol style="list-style-type: none"> If the RxD_ALARM input signal pulses "High" for any given STS-1 signal (within the incoming STS-12), then the XRT94L43 will automatically declare the AIS-P defect for that particular STS-1 channel. Tie this pin to GND if the STS-12/STM-4 Telecom Bus Interface has been configured to operate in the Re-Phase ON Mode or is disabled.
U3 V3 U2 T1 V5 U1 W1 V1	RxD_D0 RxD_D1 RxD_D2 RxD_D3 RxD_D4 RxD_D5 RxD_D6 RxD_D7	I	TTL	<p>Receive STS-12/STM-4 Receive Telecom Bus - Receive Input Data Bus pins:</p> <p>These 8 input pins function as the "Receive STS-12/STM4 Receive Telecom Bus" Receive Input data bus. All Incoming STS-12/STM-4 data is sampled and latched (into the XRT94L43 via these input pins) upon the rising edge of the RxA_CLK input pin.</p> <p>NOTES:</p> <ol style="list-style-type: none"> The user must insure that the MSB (Most Significant bit) of each incoming byte is input to the RxD_D7 input pin. The user must also insure that the LSB (Least Significant bit) of each incoming byte is input to the RxD_D0 input pin. The user should tie these pins to GND if the STS-12/STM-4 Telecom Bus is not enabled.

SONET/SDH OVERHEAD INTERFACE - TRANSMIT DIRECTION

PIN #	SIGNAL NAME	I/O	SIGNAL TYPE	DESCRIPTION
H2	TxTOHClk	O	CMOS	<p>Transmit TOH Input Port - Clock Output:</p> <p>This output pin, along with the TxTOHEnable, TxTOHFrame output pins and the TxTOH and TxTOHIns input pins function as the Transmit TOH Input Port.</p> <p>The Transmit TOH Input Port allows the user to insert their own value for the TOH bytes (in the outbound STS-12/STM-4 signal).</p> <p>This output pin provides a clock signal. If the TxTOHEnable output pin is "High" and if the TxTOHIns input pin is pulled "High", then the user is expected to provide a given bit (within the TOH) to the TxTOH input pin, upon the falling edge of this clock signal. The data, residing on the TxTOH input pin will be latched into the XRT94L43 upon the rising edge of this clock signal.</p> <p>NOTE: <i>The Transmit TOH Input Port only support the insertion of the TOH within the first STS-1, within the outbound STS-12 signal.</i></p>
H4	TxTOHEnable	O	CMOS	<p>Transmit TOH Input Port - TOH Enable (or READY) indicator:</p> <p>This output pin, along with the TxTOHClk, TxTOHFrame output pins and the TxTOH and TxTOHIns input pins function as the Transmit TOH Input Port.</p> <p>This output pin will toggle and remain "High" anytime the Transmit TOH Input Port is ready to externally accept TOH data.</p> <p>If it is desired to externally insert a value of TOH into the outbound STS-12 data stream via the Transmit TOH Input Port, then do the following:</p> <ul style="list-style-type: none"> • Continuously sample the state of TxTOHFrame and this output pin upon the rising edge of TxTOHClk. • Whenever this output pin pulses "High", then the user's external circuitry should drive the TxTOHIns input pin "High". • Next, the user should output the next TOH bit, onto the TxTOH input pin, upon the falling edge of TxTOHClk.
D1	TxTOH	I	TTL	<p>Transmit TOH Input Port - Input Pin:</p> <p>This input pin, along with the TxTOHIns input pin, the TxTOHEnable and TxTOHFrame and TxTOHClk output pins function as the Transmit TOH Input Port.</p> <p>If it is desired to externally insert a value of TOH into the outbound STS-12 data stream via the Transmit TOH Input Port, then do the following:</p> <ul style="list-style-type: none"> • Continuously sample the state of TxTOHFrame and TxTOHEnable upon the rising edge of TxTOHClk. • Whenever TxTOHEnable pulses "High", then the user's external circuitry should drive the TxTOHIns input pin "High". • Next, the user should output the next TOH bit, onto this input pin, upon the falling edge of TxTOHClk. The Transmit TOH Input Port will sample the data (on this input pin) upon the rising edge of TxTOHClk. <p>NOTE: <i>Data at this input pin will be ignored (e.g., not sampled) unless the TxTOHEnable output pin is "High" and the TxTOHIns input pin is pulled "High".</i></p>

SONET/SDH OVERHEAD INTERFACE - TRANSMIT DIRECTION

PIN #	SIGNAL NAME	I/O	SIGNAL TYPE	DESCRIPTION
G4	TxTOHFrame	O	CMOS	<p>Transmit TOH Input Port - STS-12/STM-4 Frame Indicator:</p> <p>This output pin, along with TxTOHClk, TxTOHEnable output pins, and the TxTOH and TxTOHIns input pins function as the Transmit TOH Input Port.</p> <p>This output pin will pulse "High" (for one period of TxTOHClk), one TxTOHClk clock period prior to the first TOH bit of a given STS-12 frame, being expected via the TxTOH input pin.</p> <p>If it is desired to externally insert a value of TOH into the outbound STS-12 data stream via the Transmit TOH Input Port, then do the following:</p> <ul style="list-style-type: none"> • Continuously sample the state of TxTOHEnable and this output pin upon the rising edge of TxTOHClk. • Whenever the TxTOHEnable output pin pulse "High", then the user's external circuitry should drive the TxTOHIns input pin "High". • Next, the user should output the next TOH bit, onto the TxTOH input pin, upon the falling edge of TxTOHClk. <p>NOTE: The external circuitry (which is being interfaced to the Transmit TOH Input Port can use this output pin to denote the boundary of STS-12 frames.</p>
C1	TxTOHIns	I	TTL	<p>Transmit TOH Input Port - Insert Enable Input Pin:</p> <p>This input pin, along with the TxTOH input pin, and the TxTOHEnable, TxTOHFrame and TxTOHClk output pins function as the Transmit TOH Input Port.</p> <p>This input pin is used to either enable or disable the Transmit TOH Input Port.</p> <p>If this input pin is "Low", then the Transmit TOH Input Port will be disabled and will not sample and insert (into the outbound STS-12 data stream) any data residing on the TxTOH input, upon the rising edge of TxTOHClk.</p> <p>If this input pin is "High", then the Transmit TOH Input Port will be enabled. In this mode, whenever the TxTOHEnable output pin is also "High", the Transmit TOH Input Port will sample and latch any data that is presented on the TxTOH input pin, upon the rising edge of TxTOHClk.</p> <p>If it is desired to externally insert a value of TOH into the outbound STS-12 data stream via the Transmit TOH Input Port, then do the following:</p> <ul style="list-style-type: none"> • Continuously sample the state of TxTOHFrame and TxTOHEnable upon the rising edge of TxTOHClk. • Whenever the TxTOHEnable output pin is sampled "High" then the user's external circuitry should drive this input pin "High". • Next, the user should output the next TOH bit, onto the TxTOH input pin, upon the falling edge of TxTOHClk. The Transmit TOH Input Port will sample the data (on this input pin) upon the rising edge of TxTOHClk. <p>NOTE: Data applied to the TxTOH input pin will be ignored (e.g., not sampled) unless then the TxTOHEnable and this input pin are each "High".</p>

SONET/SDH OVERHEAD INTERFACE - TRANSMIT DIRECTION

PIN #	SIGNAL NAME	I/O	SIGNAL TYPE	DESCRIPTION
G3	TxDCCEnable	O	CMOS	<p>Transmit - Line DCC Input Port - Enable Output Pin:</p> <p>This output pin, along with the TxTOHClk output pin and the TxLDCC input pin are used to insert the value for the D4, D5, D6, D7, D8, D9, D10, D11 and D12 bytes into the Transmit STS-12 TOH Processor Block. The Transmit STS-12 TOH Processor block will accept this data and will insert into the D4, D5, D6, D7, D8, D9, D10, D11 and D12 byte-fields, within the outbound STS-12 data-stream.</p> <p>The Line DCC HDLC Controller circuitry (which is connected to the TxTOHClk, the TxLDCC and this output pin, is suppose to do the following.</p> <ol style="list-style-type: none"> 1. It should continuously monitor the state of this output pin. 2. Whenever this output pin pulses "High", then the Line DCC HDLC Controller circuitry should place the next Line DCC bit (to be inserted into the Transmit STS-12 TOH Processor block) onto the TxLDCC input pin, upon the falling edge of TxTOHClk. 3. Any data that is placed on the TxLDCC input pin, will be sampled upon the rising edge of TxOHClk.
J4	TxDCCEnable	O	CMOS	<p>Transmit - Section DCC Input Port - Enable Output Pin:</p> <p>This output pin, along with the TxTOHClk output pin and the TxSDCC input pin are used to insert the value for the D1, D2 and D3 bytes, into the Transmit STS-12 TOH Processor Block. The Transmit STS-12 TOH Processor block will accept this data and will insert into the D1, D2 and D3 byte-fields, within the outbound STS-12 data-stream.</p> <p>The Section DCC HDLC Controller circuitry (which is connected to the TxTOHClk, the TxSDCC and this output pin, is suppose to do the following.</p> <ol style="list-style-type: none"> 1. It should continuously monitor the state of this output pin. 2. Whenever this output pin pulses "High", then the Section DCC HDLC Controller circuitry should place the next Section DCC bit (to be inserted into the Transmit STS-12 TOH Processor block) onto the TxSDCC input pin, upon the falling edge of TxTOHClk. 3. Any data that is placed on the TxSDCC input pin, will be sampled upon the rising edge of TxOHClk.
E2	TxDCC	I	TTL	<p>Transmit - Section DCC Input Port - Input Pin:</p> <p>This input pin, along with the TxSDCCEnable and the TxTOHClk output pins are used to insert a value for the D1, D2 and D3 bytes, into the Transmit STS-12 TOH Processor Block. The Transmit STS-12 TOH Processor block will accept this data and insert it into the D1, D2 and D3 byte fields, within the outbound STS-12 data-stream.</p> <p>The Section DCC HDLC Circuitry that is interfaced to this input pin, the TxSDCCEnable and the TxTOHClk pins is suppose to do the following.</p> <ol style="list-style-type: none"> 1. It should continuously monitor the state of the TxSDCCEnable input pin. 2. Whenever the TxSDCCEnable input pin pulses "High", then the Section DCC HDLC Controller circuitry should place the next Section DCC bit (to be inserted into the Transmit STS-12 TOH Processor block) onto this input pin upon the falling edge of TxTOHClk. 3. Any data that is placed on the TxSDCC input pin, will be sampled upon the rising edge of TxTOHClk. <p>NOTE: Tie this pin to GND if it is not going to be used.</p>

SONET/SDH OVERHEAD INTERFACE - TRANSMIT DIRECTION

PIN #	SIGNAL NAME	I/O	SIGNAL TYPE	DESCRIPTION
H3	TxDCC	I	TTL	<p>Transmit - Line DCC Input Port:</p> <p>This input pin, along with the TxLDCCEnable and the TxTOHClk pins are used to insert a value for the D4, D5, D6, D7, D8, D9, D10, D11 and D12 bytes, into the Transmit STS-12 TOH Processor Block. The Transmit STS-12 TOH Processor block will accept this data and insert it into the D4, D5, D6, D7, D8, D9, D10, D11 and D12 byte-fields, within the outbound STS-12 data-stream.</p> <p>Whatever Line DCC HDLC Controller Circuitry is interface to the this input pin, the TxLDCCEnable and the TxTOHClk is suppose to do the following.</p> <ol style="list-style-type: none"> 1. It should continuously monitor the state of the TxLDCCEnable input pin. 2. Whenever the TxLDCCEnable input pin pulses "High", then the Section DCC Interface circuitry should place the next Line DCC bit (to be inserted into the Transmit STS-12 TOH Processor block) onto the TxLDCC input pin, upon the falling edge of TxTOHClk. 3. Any data that is placed on the TxLDCC input pin, will be sampled upon the rising edge of TxTOHClk. <p>NOTE: Tie this pin to GND, if it is not going to be used.</p>
F4	TxE1F1E2Enable	O	CMOS	<p>Transmit E1-F1-E2 Byte Input Port - Enable (or Ready) Indicator Output Pin:</p> <p>This output pin, along with the TxTOHClk output pin and the TxE1F1E2 input pin are used to insert a value for the E1, F1 and E2 bytes, into the Transmit STS-12 TOH Processor Block. The Transmit STS-12 TOH Processor block will accept this data and will insert into the E1, F1 and E2 byte-fields, within the outbound STS-12 data-stream.</p> <p>Whatever external circuitry (which is connected to the TxTOHClk, the TxE1F1E2 and this output pin, is suppose to do the following.</p> <ol style="list-style-type: none"> 1. It should continuously monitor the state of this output pin. 2. Whenever this output pin pulses "High", then the external circuitry should place the next orderwire bit (to be inserted into the Transmit STS-12 TOH Processor block) onto the TxE1F1E2 input pin, upon the falling edge of TxTOHClk. <p>Any data that is placed on the TxE1F1E2 input pin, will be sampled upon the rising edge of TxOHClk.</p>
D2	TxE1F2E2Frame	O	CMOS	<p>Transmit E1-F1-E2 Byte Input Port - Framing Output Pin:</p> <p>This output pin pulses "High" for one period of TxTOHClk, one TxTOHClk bit-period prior to the Transmit E1-F1-E2 Byte Input Port expecting the very first byte of the E1 byte, within a given outbound STS-12 frame.</p>

SONET/SDH OVERHEAD INTERFACE - TRANSMIT DIRECTION

PIN #	SIGNAL NAME	I/O	SIGNAL TYPE	DESCRIPTION
J6	TxE1F1E2	I	TTL	<p>Transmit E1-F1-E2 Byte Input Port - Input Pin:</p> <p>This input pin, along with the TxE1F1E2Enable and the TxTOHClk output pins are used to insert a value for the E1, F1 and E2 bytes, into the Transmit STS-12 TOH Processor Block. The Transmit STS-12 TOH Processor block will accept this data and insert it into the E1, F1 and E2 byte fields, within the outbound STS-12 data-stream.</p> <p>Whatever external circuitry that is interfaced to this input pin, the TxE1F1E2Enable and the TxTOHClk pins is suppose to do the following.</p> <ol style="list-style-type: none"> 1. It should continuously monitor the state of the TxE1F1E2Enable input pin. 2. Whenever the TxE1F1E2Enable input pin pulses "High", then the external circuitry should place the next orderwire bit (to be inserted into the Transmit STS-12 TOH Processor block) onto this input pin upon the falling edge of TxTOHClk. 3. Any data that is placed on the TxE1F1E2 input pin, will be sampled upon the rising edge of TxTOHClk. <p>NOTE: Tie this pin to GND if it is not going to be used.</p>

SONET/SDH OVERHEAD INTERFACE - TRANSMIT DIRECTION

PIN #	SIGNAL NAME	I/O	SIGNAL TYPE	DESCRIPTION
C10 B13 AD12 AD8 A16 D18 AD13 AE8 D13 C18 AE17 AB12 D9 C13 AE11 AF4	TxPOH_0 TxPOH_1 TxPOH_2 TxPOH_3 TxPOH_4 TxPOH_5 TxPOH_6 TxPOH_7 TxPOH_8 TxPOH_9 TxPOH_10 TxPOH_11 TxPOH_12 TxPOH_13 TxPOH_14 TxPOH_15	I	TTL	<p>Transmit Path Overhead Input Port - Input Pin.</p> <p>These input pins allow the following actions.</p> <ol style="list-style-type: none"> 1. Insertion of the POH data into each of the 12 Transmit SONET POH Processor blocks (for insertion and transmission via the outbound STS-12 signal). 2. Insertion of the POH data into each of the 12 Transmit STS-1 POH Processor blocks (for insertion and transmission via each of the outbound STS-1 signals). 3. Insertion of the TOH data into each of the 12 Transmit STS-1 TOH Processor blocks (for insertion and transmission via each of the outbound STS-1 signals). <p>The function of these input pins, depends upon whether or not the TOH data is inserted into the 12 Transmit STS-1 TOH Processor blocks.</p> <p>If the user is only inserting POH data via these input pins:</p> <p>In this mode, the external circuitry (which is being interfaced to the Transmit Path Overhead Input Port is suppose to monitor the following output pins.</p> <ul style="list-style-type: none"> • TxPOHFrame_n • TxPOHEnable_n • TxPOHClk_n <p>The TxPOHFrame_n output pin will toggle "High" upon the falling edge of TxPOHClk_n approximately one TxPOHClk_n period prior to the TxPOH port being ready to accept and process the first bit within the J1 byte (e.g., the first POH byte). The TxPOHFrame_n output pin will remain "High" for eight consecutive TxPOHClk_n periods. The external circuitry should use this pin to note STS-1 SPE frame boundaries.</p> <p>The TxPOHEnable_n output pin will toggle "High" upon the falling edge of TxPOHClk_n approximately one TxPOHClk_n period prior to the TxPOH port being ready to accept and process the first bit within a given POH byte.</p> <p>To externally insert a given POH byte, (1) assert the TxPOHIns_n input pin by toggling it "High" and (2) place the value of the first bit (within this particular POH byte) on this input pin upon the very next falling edge of TxPOHClk_n. This data bit will be sampled upon the very next rising edge of TxPOHClk_n. The external circuitry should continue to keep the TxPOHIns_n input pin "High" and advancing the next bits (within the POH bytes) upon each falling edge of TxPOHClk_n.</p> <p>If the user is inserting both POH and TOH data via these input pins:</p> <p>In this mode, the external circuitry (which is being interfaced to the Transmit Path Overhead Input Port is suppose to monitor the following output pins.</p> <ul style="list-style-type: none"> • TxPOHFrame_n • TxPOHEnable_n • TxPOHClk_n <p>(continued below)</p>

SONET/SDH OVERHEAD INTERFACE - TRANSMIT DIRECTION

PIN #	SIGNAL NAME	I/O	SIGNAL TYPE	DESCRIPTION
C10 B13 AD12 AD8 A16 D18 AD13 AE8 D13 C18 AE17 AB12 D9 C13 AE11 AF4	TxPOH_0 TxPOH_1 TxPOH_2 TxPOH_3 TxPOH_4 TxPOH_5 TxPOH_6 TxPOH_7 TxPOH_8 TxPOH_9 TxPOH_10 TxPOH_11 TxPOH_12 TxPOH_13 TxPOH_14 TxPOH_15	I	TTL	<p>If the user is inserting both POH and TOH data via these input pins:</p> <p>(Continued)</p> <p>The TxPOHFrame_n output pin will toggle "High" twice during a given STS-1 frame period. First, this output pin will toggle "High" coincident with the TxPOH port being ready to accept and process the A1 byte (e.g., the very first TOH byte). Second, this output pin will toggle "High" coincident with the TxPOH port being ready to accept and process the J1 byte (e.g., the very first POH byte).</p> <p>If the externally circuitry samples the TxPOHFrame_n output pin "High", and the TxPOHEnable_n output pin "Low", then the TxPOH port is now ready to accept and process the very first TOH byte.</p> <p>If the externally circuitry samples the TxPOHFrame_n output pin "High" and the TxPOHEnable_n output pin "High", then the TxPOH port is now ready to accept and process the very first POH byte.</p> <p>To externally insert a given POH or TOH byte, do the following;</p> <ol style="list-style-type: none"> (1) Assert the TxPOHIns_n input pin by toggling it "High" and, (2) place the value of the first bit (within this particular POH or TOH byte) on this input upon the very next falling edge of TxPOHClk_n. <p>This data bit will be sampled upon the very next rising edge of TxPOHClk_n. The external circuitry should continue to keep the TxPOHIns_n input pin "High" and advancing the next bits (within the POH bytes) upon each falling edge of TxPOHClk_n.</p> <p>NOTES:</p> <ol style="list-style-type: none"> 1. If POH data is externally inserted into each of the 12 Transmit SONET POH Processor blocks, then these input pins cannot be used to externally insert POH data into each of the 12 Transmit STS-1 POH Processor blocks. 2. TOH data can be externally inserted into each of the 12 Transmit STS-1 TOH Processor blocks, only if POH data is NOT externally inserted into each of the 12 Transmit SONET POH Processor blocks.
B10 A15 AC13 AD9 B16 D19 AE13 AE9 D14 C19 AF19 AB13 E10 C14 AF11 AF5	TxPOHClk_0 TxPOHClk_1 TxPOHClk_2 TxPOHClk_3 TxPOHClk_4 TxPOHClk_5 TxPOHClk_6 TxPOHClk_7 TxPOHClk_8 TxPOHClk_9 TxPOHClk_10 TxPOHClk_11 TxPOHClk_12 TxPOHClk_13 TxPOHClk_14 TxPOHClk_15	O	CMOS	<p>Transmit Path Overhead Input Port - Clock Output pin:</p> <p>These output pins, along with TxPOH_n, TxPOHEnable_n, TxPOHIns_n and TxPOHFrame_n function as the Transmit Path Overhead (TxPOH) Input Port.</p> <p>The TxPOHFrame_n and TxPOHEnable_n output pins are updated upon the falling edge this clock output signal. The TxPOHIns_n input pins and the data residing on the TxPOH_n input pins are sampled on the rising edge of this clock signal.</p>

SONET/SDH OVERHEAD INTERFACE - TRANSMIT DIRECTION

PIN #	SIGNAL NAME	I/O	SIGNAL TYPE	DESCRIPTION
A6	TxPOHFrame_0	O	CMOS	<p>Transmit Path Overhead Input Port - Frame Output pin:</p> <p>These output pins, along with the TxPOH_n, TxPOHEnable_n, TxPOHIns_n and TxPOHCik_n function as the Transmit Path Overhead Input Port.</p> <p>The function of these output pins depends upon whether POH or TOH data is inserted via the TxPOH_n input pins.</p> <p>If the user is only inserting POH data via these input pins:</p> <p>In this mode, the TxPOH port will pulse these output pins "High" whenever it is ready to accept and process the J1 byte (e.g., the very first POH byte) via this port.</p> <p>If the user is inserting both POH and TOH data via these input pins:</p> <p>In this mode, the TxPOH port will pulse these output pins "High" coincident with the following.</p> <ol style="list-style-type: none"> Whenever the TxPOH port is ready to accept and process the A1 byte (e.g., the very first TOH byte) via this port. Whenever the TxPOH port is ready to accept and process the J1 byte (e.g., the very first POH byte) via this port. <p>NOTE: The external circuitry can determine whether the TxPOH port is expecting the A1 byte or the J1 byte, by checking the state of the corresponding TxPOHEnable output pin. If the TxPOHEnable_n output pin is "Low" while the TxPOHFrame_n output pin is "High", then the TxPOH port is ready to process the A1 (TOH) bytes.</p> <p>If the TxPOHEnable_n output pin is "High" while the TxPOHFrame_n output pin is "High", then the TxPOH port is ready to process the J1 (POH) bytes.</p>
A11	TxPOHFrame_1			
AC12	TxPOHFrame_2			
AD7	TxPOHFrame_3			
D8	TxPOHFrame_4			
B12	TxPOHFrame_5			
AF14	TxPOHFrame_6			
AB10	TxPOHFrame_7			
A12	TxPOHFrame_8			
C17	TxPOHFrame_9			
AA15	TxPOHFrame_10			
AC10	TxPOHFrame_11			
D7	TxPOHFrame_12			
E11	TxPOHFrame_13			
AC11	TxPOHFrame_14			
AD6	TxPOHFrame_15			

SONET/SDH OVERHEAD INTERFACE - TRANSMIT DIRECTION

PIN #	SIGNAL NAME	I/O	SIGNAL TYPE	DESCRIPTION
A7 C12 AE12 AC9 E9 A13 AF16 AB11 E13 D17 AC16 AF8 E8 E12 AF9 AC8	TxPOHIns_0 TxPOHIns_1 TxPOHIns_2 TxPOHIns_3 TxPOHIns_4 TxPOHIns_5 TxPOHIns_6 TxPOHIns_7 TxPOHIns_8 TxPOHIns_9 TxPOHIns_10 TxPOHIns_11 TxPOHIns_12 TxPOHIns_13 TxPOHIns_14 TxPOHIns_15	I	TTL	<p>Transmit Path Overhead Input Port - Insert Enable Input pin:</p> <p>These input pins, along with TxPOH_n, TxPOHEnable_n, TxPOHFrame_n and TxPOHClk_n function as the Transmit Path Overhead (TxPOH) Input Port.</p> <p>These input pins are used to enable or disable the TxPOH input port. If these input pins are pulled "High", then the TxPOH port will sample and latch data via the corresponding TxPOH input pins, upon the rising edge of TxPOHClk_n.</p> <p>Conversely, if these input pins are pulled "Low", then the TxPOH port will NOT sample and latch data via the corresponding TxPOH input pins.</p> <p>NOTE: If the TxPOHIns_n input pin is pulled "Low", this setting will be overridden if, the Transmit SONET/STS-1 POH Processor or Transmit STS-1 TOH Processor blocks are configured to accept certain POH or TOH overhead bytes via the external port.</p>
D10 D15 AB14 AE7 A10 A17 AC14 AF7 C11 B14 AD14 AE10 B11 D16 AF13 AB9	TxPOHEnable_0 TxPOHEnable_1 TxPOHEnable_2 TxPOHEnable_3 TxPOHEnable_4 TxPOHEnable_5 TxPOHEnable_6 TxPOHEnable_7 TxPOHEnable_8 TxPOHEnable_9 TxPOHEnable_10 TxPOHEnable_11 TxPOHEnable_12 TxPOHEnable_13 TxPOHEnable_14 TxPOHEnable_15	O	CMOS	<p>Transmit Path Overhead Input Port - POH Indicator Output pin:</p> <p>These output pins, along with TxPOH_n, TxPOHIns_n, TxPOHFrame_n and TxPOHClk_n function as the Transmit Path Overhead (TxPOH) Input Port.</p> <p>These output pins will pulse "High" anytime the TxPOH port is ready to accept and process POH bytes. These output pins will be "Low" at all other times.</p>

STS-3/STM-1 TELECOM BUS INTERFACE - TRANSMIT DIRECTION

PIN #	SIGNAL NAME	I/O	SIGNAL TYPE	DESCRIPTION
E15	STS3TxA_CLK_0 TxSBCLK_0 DMO_0	I	TTL	<p>STS-3 Transmit Telecom Bus Clock Input/STM-1 Sub-Rate Clock/DMO_0 (General Purpose) input Pin:</p> <p>The function of this input pin depends upon whether or not the STS-3/STM-1 Telecom Bus Interface for Channel 0 has been enabled.</p> <p>If STS-3/STM-1 Telecom Bus (Channel 0) has been enabled - STS-3 Transmit Telecom Bus Transmit Clock Input - Channel 0:</p> <p>This input clock signal functions as the clock source for the STS-3/STM-1 Transmit Telecom Bus, associated with Channel 0. All input signals (e.g., STS3TxA_ALARM_0, STS3TxA_D_0[7:0], STS3TxA_DP_0, STS3TxA_PL_0, STS3TxA_C1J1_0) are sampled upon the falling edge of this input clock signal.</p> <p>This clock signal should operate at 19.44MHz.</p> <p>If STS-3/STM-1 Telecom Bus (Channel 0) is disabled - DMO_0 (General Purpose) Input Pin:</p> <p>This input pin can be used as a general purpose input pin.</p> <p>The state of this input pin can be determined by reading the state of Bit 2 (DMO) within the Line Interface Scan Register associated with Channel 0 (Address = 0x1E, 0x81), (Direct Address = 0x1F81).</p> <p>NOTE: For Product Legacy purposes, this pin is called DMO_0, because one possible application is to tie this input pin to a DMO (Drive Monitor Output) output pin, from one of Exar's XRT73L0X/XRT75L0X DS3/E3/STS-1 LIU devices. However, this input pin, and the corresponding register bit can be used for any purpose.</p>
C26	STS3TxA_CLK_1 TxSBCLK_1 DMO_1	I	TTL	<p>STS-3 Transmit Telecom Bus Clock Input/STM-1 Sub-Rate Clock/DMO_1 (General Purpose) input Pin:</p> <p>The function of this input pin depends upon whether or not the STS-3/STM-1 Telecom Bus Interface for Channel 1 has been enabled.</p> <p>If STS-3/STM-1 Telecom Bus (Channel 1) has been enabled - STS-3 Transmit Telecom Bus Clock Input - Channel 1:</p> <p>This input clock signal functions as the clock source for the STS-3/STM-1 Transmit Telecom Bus, associated with Channel 1. All input signals, (e.g., STS3TxA_ALARM_1, STS3TxA_D_1[7:0], STS3TxA_DP_1, STS3TxA_PL_1, STS3TxA_C1J1_1) are sampled upon the falling edge of this input clock signal.</p> <p>This clock signal should operate at 19.44MHz.</p> <p>If STS-3/STM-1 Telecom Bus (Channel 1) is disabled - DMO_1 (General Purpose) Input Pin:</p> <p>This input pin can be used as a general purpose input pin.</p> <p>The state of this input pin can be determined by reading the state of Bit 2 (DMO) within the Line Interface Scan Register associated with Channel 1 (Address = 0x2E, 0x81), (Direct Address = 0x2F81).</p> <p>NOTE: For Product Legacy purposes, this pin is called DMO_1 because one possible application is to tie this input pin to a DMO (Drive Monitor Output) output pin, from one of Exar's XRT73L0X/XRT75L0X DS3/E3/STS-1 LIU devices. However, this input pin, and the corresponding register bit can be used for any purpose.</p>

STS-3/STM-1 TELECOM BUS INTERFACE - TRANSMIT DIRECTION

PIN #	SIGNAL NAME	I/O	SIGNAL TYPE	DESCRIPTION
AE25	STS3TxA_CLK_2 TxSBCLK_2 DMO_2	I	TTL	<p>STS-3 Transmit Telecom Bus Clock Input/STM-1 Sub-Rate Clock/DMO_2 (General Purpose) input Pin: The function of this input pin depends upon whether or not the STS-3/STM-1 Telecom Bus Interface for Channel 2 has been enabled.</p> <p>If STS-3/STM-1 Telecom Bus (Channel 2) has been enabled - STS-3 Transmit Telecom Bus Transmit Clock Input - Channel 2: This input clock signal functions as the clock source for the STS-3/STM-1 Transmit Telecom Bus, associated with Channel 2. All input signals, (e.g., STS3TxA_ALARM_2, STS3TxA_D_2[7:0], STS3TxA_DP_2, STS3TxA_PL_2, STS3TxA_C1J1_2) are sampled upon the falling edge of this input clock signal. This clock signal should operate at 19.44MHz.</p> <p>If STS-3/STM-1 Telecom Bus (Channel 2) is disabled - DMO_2 - Drive Monitor Output Input (from XRT73L0X LIU IC) - Channel 2: This input pin can be used as a general purpose input pin. The state of this input pin can be determined by reading the state of Bit 2 (DMO) within the Line Interface Scan Register associated with Channel 2 (Indirect Address = 0x3E, 0x81), (Direct Address = 0x3F81).</p> <p><i>NOTE: For Product Legacy purposes, this pin is called DMO_2 because one possible Application is to tie this input pin to a DMO (Drive Monitor Output) output pin, from one of Exar's XRT73L0X/XRT75L0X DS3/E3/STS-1 LIU devices. However, this input pin, and the corresponding register bit can be used for any purpose.</i></p>
AD17	STS3TxA_CLK_3 TxSBCLK_3 DMO_3	I	TTL	<p>STS-3 Transmit Telecom Bus Clock Input/STM-1 Sub-Rate Clock/DMO_3 (General Purpose) input Pin: The function of this input pin depends upon whether or not the STS-3/STM-1 Telecom Bus Interface for Channel 3 has been enabled.</p> <p>If STS-3/STM-1 Telecom Bus (Channel 3) has been enabled - STS-3 Transmit Telecom Bus Clock Input - Channel 3: This input clock signal functions as the clock source for the STS-3/STM-1 Transmit Telecom Bus, associated with Channel 3. All input signals (e.g., STS3TxA_ALARM_3, STS3TxA_D_3[7:0], STS3TxA_DP_3, STS3TxA_PL_3, STS3TxA_C1J1_3) are sampled upon the falling edge of this input clock signal. This clock signal should operate at 19.44MHz.</p> <p>If STS-3/STM-1 Telecom Bus (Channel 3) is disabled - DMO_3 (General Purpose) Input Pin: This input pin can be used as a general purpose input pin. The state of this input pin can be determined by reading the state of Bit 3 (DMO) within the Line Interface Scan Register associated with Channel 3 (Address = 0x4E, 0x81), (Direct Address = 0x4F81).</p> <p><i>NOTE: For Product Legacy purposes, this pin is called DMO_3, because one possible application is to tie this input pin to a DMO (Drive Monitor Output) output pin, from one of Exar's XRT73L0X/XRT75L0X DS3/E3/STS-1 LIU devices. However, this input pin, and the corresponding register bit can be used for any purpose.</i></p>

STS-3/STM-1 TELECOM BUS INTERFACE - TRANSMIT DIRECTION

PIN #	SIGNAL NAME	I/O	SIGNAL TYPE	DESCRIPTION
E14	STS3TxA_PL_0 TxSBFrame_0 RLOL_0	I	TTL	<p>STS-3/STM-1 Transmit Telecom Bus - Payload Indicator Signal - Channel 0/RLOL_0 (General Purpose) input Pin:</p> <p>The function of this input depends upon whether or not the STS-3/STM-1 Telecom Bus Interface for Channel 0 has been enabled.</p> <p>If STS-3/STM-1 Telecom Bus (Channel 0) has been enabled - STS-3/STM-1 Transmit Telecom Bus - Payload Indicator Signal - Channel 0:</p> <p>This input pin indicates whether or not Transport Overhead (TOH) bytes are being input via the TXA_D_0[7:0] input pins.</p> <p>This input pin should be pulled "Low" for the duration that the STS-3/STM-1 Transmit Telecom Bus is receiving a TOH byte, via the TXA_D_0[7:0] input pins.</p> <p><i>NOTE: This input signal is sampled upon the falling edge of STS3TxA_CLK_0.</i></p> <p>If STS-3/STM-1 Telecom Bus (Channel 0) is disabled - RLOL_0 (General Purpose) Input Pin.</p> <p>This input pin can be used as a general purpose input pin.</p> <p>The state of this input pin can be determined by reading the state of Bit 1 (RLOL) within the Line Interface Scan Register associated with Channel 0 (Address = 0x1E, 0x81), (Direct Address = 0x1F81).</p> <p><i>NOTE: For Product Legacy purposes, this pin is called RLOL_0 because one possible application is to tie this input pin to a RLOL (Receive Loss of Lock) output pin, from one of Exar's XRT73L0X/XRT75L0X DS3/E3/STS-1 LIU devices. However, this input pin and the corresponding register bit can be used for any purpose.</i></p>

STS-3/STM-1 TELECOM BUS INTERFACE - TRANSMIT DIRECTION

PIN #	SIGNAL NAME	I/O	SIGNAL TYPE	DESCRIPTION
A26	STS3TxA_PL_1 TxSBFrame_1 RLOL_1	I	TTL	<p>STS-3/STM-1 Transmit Telecom Bus - Payload Indicator Signal - Channel 1/RLOL_1 (General Purpose) input Pin:</p> <p>The function of this input pin depends upon whether or not the STS-3/STM-1 Telecom Bus Interface for Channel 1 has been enabled.</p> <p>If STS-3/STM-1 Telecom Bus (Channel 1) has been enabled - STS-3/STM-1 Transmit Telecom Bus - Payload Indicator Signal - Channel 1:</p> <p>This input pin indicates whether or not Transport Overhead (TOH) bytes are being input via the TXA_D_1[7:0] input pins.</p> <p>This input pin should be pulled "Low" for the duration that the STS-3/STM-1 Transmit Telecom Bus is receiving a TOH byte, via the TXA_D_1[7:0] input pins.</p> <p>NOTE: This input signal is sampled upon the falling edge of STS3TxA_CLK_1.</p> <p>If STS-3/STM-1 Telecom Bus (Channel 1) is disabled - RLOL_1 (General Purpose) Input Pin:</p> <p>This input pin can be used as a general purpose input pin.</p> <p>The state of this input pin can be determined by reading the state of Bit 1 (RLOL) within the Line Interface Scan Register associated with Channel 1 (Indirect Address = 0x2E, 0x81), (Direct Address = 0x2F81).</p> <p>NOTE: For Product Legacy purposes, this pin is called RLOL_1 because one possible application is to tie this input pin to a RLOL (Receive Loss of Lock) output pin, from one of Exar's XRT73L0X/XRT75L0X DS3/E3/STS-1 LIU devices. However, this input pin and the corresponding register bit can be used for any purpose.</p>

STS-3/STM-1 TELECOM BUS INTERFACE - TRANSMIT DIRECTION

PIN #	SIGNAL NAME	I/O	SIGNAL TYPE	DESCRIPTION
AD25	STS3TxA_PL_2 TxSBFrame_2 RLOL_2	I	TTL	<p>STS-3/STM-1 Transmit Telecom Bus - Payload Indicator Signal - Channel 2/RLOL_2 (General Purpose) input Pin:</p> <p>The function of this input pin depends upon whether or not the STS-3/STM-1 Telecom Bus Interface for Channel 2 has been enabled.</p> <p>If STS-3/STM-1 Telecom Bus (Channel 2) has been enabled - STS-3/STM-1 Transmit Telecom Bus - Payload Indicator Signal - Channel 2:</p> <p>This input pin indicates whether or not Transport Overhead (TOH) bytes are being input via the TXA_D_2[7:0] input pins.</p> <p>This input pin should be pulled "Low" for the duration that the STS-3/STM-1 Transmit Telecom Bus is receiving a TOH byte, via the TXA_D_2[7:0] input pins.</p> <p>NOTE: <i>This input signal is sampled upon the falling edge of STS3TxA_CLK_2.</i></p> <p>If STS-3/STM-1 Telecom Bus (Channel 2) is disabled - RLOL_2 (General Purpose) Input Pin:</p> <p>This input pin can be used as a general purpose input pin.</p> <p>The state of this input pin can be determined by reading the state of Bit 1 (RLOL) within the Line Interface Scan Register associated with Channel 2 (Indirect Address = 0x3E, 0x81), (Direct Address = 0x3F81).</p> <p>NOTE: <i>For Product Legacy purposes, this pin is called RLOL_2 because one possible application is to tie this input pin to a RLOL (Receive Loss of Lock) output pin, from one of Exar's XRT73L0X/XRT75L0X DS3/E3/STS-1 LIU devices. However, this input pin and the corresponding register bit can be used for any purpose.</i></p>

STS-3/STM-1 TELECOM BUS INTERFACE - TRANSMIT DIRECTION

PIN #	SIGNAL NAME	I/O	SIGNAL TYPE	DESCRIPTION
AB17	STS3TxA_PL_3 TxSBFrame_3 RLOL_3	I	TTL	<p>STS-3/STM-1 Transmit Telecom Bus - Payload Indicator Signal - Channel 3/RLOL_3 (General Purpose) input Pin: The function of this input pin depends upon whether or not the STS-3/STM-1 Telecom Bus Interface for Channel 3 has been enabled.</p> <p>If STS-3/STM-1 Telecom Bus (Channel 3) has been enabled - STS-3/STM-1 Transmit Telecom Bus - Payload Indicator Signal - Channel 3: This input pin indicates whether or not Transmit Overhead (TOH) bytes are being input via the TXA_D_3[7:0] input pins. This input pin should be pulled "Low" for the duration that the STS-3/STM-1 Transmit Telecom Bus is receiving a TOH byte, via the TXA_D_3[7:0] input pins.</p> <p><i>NOTE: This input signal is sampled upon the falling edge of STS3TxA_CLK_3.</i></p> <p>If STS-3/STM-1 Telecom Bus (Channel 3) is disabled - RLOL_3 (General Purpose) Input Pin: This input pin can be used as a general purpose input pin. The state of this input pin can be determined by reading the state of Bit 1 (RLOL) within the Line Interface Scan Register associated with Channel 3 (Indirect Address = 0x4E, 0x81), (Direct Address = 0x4F81).</p> <p><i>NOTE: For Product Legacy purposes, this pin is called RLOL_3 because one possible application is to tie this input pin to a RLOL (Receive Loss of Lock) output pin, from one of Exar's XRT73L0X/XRT75L0X DS3/E3/STS-1 LIU devices. However, this input pin and the corresponding register bit can be used for any purpose.</i></p>

STS-3/STM-1 TELECOM BUS INTERFACE - TRANSMIT DIRECTION

PIN #	SIGNAL NAME	I/O	SIGNAL TYPE	DESCRIPTION
B24	STS3TxA_C1J1_0 TxDS3FP_8 TxSTS1PL_8 TxSBFrame_0	I/O	TTL/ CMOS	<p>STS-3/STM-1 Transmit Telecom Bus C1/J1 Byte Phase Indicator Input Signal (Channel 0); DS3/E3 Frame Generator Framing Pulse Input/Output Pin - Channel 8:</p> <p>The function of this pin depends upon whether or not the STS-3/STM-1 Telecom Bus Interface for Channel 0 has been enabled.</p> <p>If STS-3/STM-1 Telecom Bus (Channel 0) has been enabled - STS-3/STM-1 Transmit Telecom Bus C1/J1 Byte Phase Indicator Input Signal (Channel 0):</p> <p>This input pin should be pulsed "High" during both of the following conditions.</p> <ol style="list-style-type: none"> 1. Whenever the C1 byte is being input to the STS-3/STM-1 Transmit Telecom Bus (TXA_D_0[7:0]) input pins. 2. Whenever the J1 byte is being input to the STS-3/STM-1 Transmit Telecom Bus (TXA_D_0[7:0]) input pins. <p>If STS-3/STM-1 Telecom Bus (Channel 0) is disabled - TxDS3FP_8 (Transmit DS3 Frame Pulse Input/Output - Channel 8):</p> <p>If the STS-3/STM-1 Telecom Bus (Channel 0) is disabled and if the DS3/E3 Framer block is enabled then this pin will function as either a Transmit Framing Reference input pin or as a Transmit Framing Reference output pin.</p> <p>If the Frame Generator (within the DS3/E3 Framer block) is configured to operate in the Loop-Timing or in the Local-Timing/Asynchronous Framing Mode:</p> <p>This pin will function as a Framing Reference Output pin. The Frame Generator block (associated with Channel 8) will pulse this output pin "High" for one DS3/E3 bit-period, one period prior to the first bit of a given DS3 or E3 frame being applied to the DS3/E3/STS1_DATA_IN_8 input pin.</p> <p>If the Frame Generator (within the DS3/E3 Framer block) is configured to operate in the Local-Timing/TxDS3FP Mode:</p> <p>This pin will function as a Framing Reference Input pin. In this mode, the user is expected to pulse this input pin "High" for one DS3 or E3 bit-period, coincident with the first bit of a given DS3 or E3 frame, being placed on the DS3/E3/STS1_DATA_IN_8 input pin. The Frame Generator block (associated with Channel 8) will synchronize its generation of DS3 or E3 frames to these framing pulses applied to this input pin.</p> <p>NOTE: This pin is inactive if the Frame Generator block, associated with Channel 8 is by-passed.</p>

STS-3/STM-1 TELECOM BUS INTERFACE - TRANSMIT DIRECTION

PIN #	SIGNAL NAME	I/O	SIGNAL TYPE	DESCRIPTION
J23	STS3TxA_C1J1_1 TxDS3FP_9 TxSBFrame_1	I/O	TTL/ CMOS	<p>STS-3/STM-1 Transmit Telecom Bus C1/J1 Byte Phase Indicator Input Signal (Channel 1); DS3/E3 Frame Generator Framing Pulse Input/Output Pin - Channel 9:</p> <p>The function of this pin depends upon whether or not the STS-3/STM-1 Telecom Bus Interface for Channel 1 has been enabled.</p> <p>If STS-3/STM-1 Telecom Bus (Channel 1) has been enabled - STS-3/STM-1 Transmit Telecom Bus C1/J1 Byte Phase Indicator Input Signal (Channel 1):</p> <p>This input pin should be pulsed "High" during both of the following conditions.</p> <ol style="list-style-type: none"> 1. Whenever the C1 byte is being input to the STS-3/STM-1 Transmit Telecom Bus (TXA_D_1[7:0]) input pins. 2. Whenever the J1 byte is being input to the STS-3/STM-1 Transmit Telecom Bus (TXA_D_1[7:0]) input pins. <p>If STS-3/STM-1 Telecom Bus (Channel 1) is disabled - TxDS3FP_9 (Transmit DS3 Frame Pulse Input/Output - Channel 9):</p> <p>If the STS-3/STM-1 Telecom Bus (Channel 1) is disabled and if the DS3/E3 Framer block is enabled then this pin will function as either a Transmit Framing Reference input pin or as a Transmit Framing Reference output pin.</p> <p>If the Frame Generator (within the DS3/E3 Framer block) is configured to operate in the Loop-Timing or in the Local-Timing/Asynchronous Framing Mode:</p> <p>This pin will function as a Framing Reference Output pin. The Frame Generator block (associated with Channel 9) will pulse this output pin "High" for one DS3/E3 bit-period, one period prior to the first bit of a given DS3 or E3 frame being applied to the DS3/E3/STS1_DATA_IN_9 input pin.</p> <p>If the Frame Generator (within the DS3/E3 Framer block) is configured to operate in the Local-Timing/TxDS3FP Mode:</p> <p>This pin will function as a Framing Reference Input pin. In this mode, the user is expected to pulse this input pin "High" for one DS3 or E3 bit-period, coincident with the first bit of a given DS3 or E3 frame, being placed on the DS3/E3/STS1_DATA_IN_9 input pin. The Frame Generator block (associated with Channel 9) will synchronize its generation of DS3 or E3 frames to these framing pulses applied to this input pin.</p> <p>NOTE: This pin is inactive if the Frame Generator block, associated with Channel 9 is by-passed.</p>

STS-3/STM-1 TELECOM BUS INTERFACE - TRANSMIT DIRECTION

PIN #	SIGNAL NAME	I/O	SIGNAL TYPE	DESCRIPTION
AF24	STS3TxA_C1J1_2 TxDS3FP_10 TxSTS1PL_10 TxSBFrame_2	I/O	TTL/ CMOS	<p>STS-3/STM-1 Transmit Telecom Bus C1/J1 Byte Phase Indicator Input Signal (Channel 2); DS3/E3 Frame Generator Framing Pulse Input/Output Pin - Channel 10:</p> <p>The function of this pin depends upon whether or not the STS-3/STM-1 Telecom Bus Interface for Channel 2 has been enabled.</p> <p>If STS-3/STM-1 Telecom Bus (Channel 2) has been enabled - STS-3/STM-1 Transmit Telecom Bus C1/J1 Byte Phase Indicator Input Signal (Channel 2):</p> <p>This input pin should be pulsed "High" during both of the following conditions.</p> <ol style="list-style-type: none"> 1. Whenever the C1 byte is being input to the STS-3/STM-1 Transmit Telecom Bus (TXA_D_2[7:0]) input pins. 2. Whenever the J1 byte is being input to the STS-3/STM-1 Transmit Telecom Bus (TXA_D_2[7:0]) input pins. <p>If STS-3/STM-1 Telecom Bus (Channel 2) is disabled - TxDS3FP_10 (Transmit DS3 Frame Pulse Input/Output - Channel 10):</p> <p>If the STS-3/STM-1 Telecom Bus (Channel 2) is disabled and if the DS3/E3 Framer block is enabled then this pin will function as either a Transmit Framing Reference input pin or as a Transmit Framing Reference output pin.</p> <p>If the Frame Generator (within the DS3/E3 Framer block) is configured to operate in the Loop-Timing or in the Local-Timing/Asynchronous Framing Mode:</p> <p>This pin will function as a Framing Reference Output pin. The Frame Generator block (associated with Channel 10) will pulse this output pin "High" for one DS3/E3 bit-period, one period prior to the first bit of a given DS3 or E3 frame being applied to the DS3/E3/STS1_DATA_IN_10 input pin.</p> <p>If the Frame Generator (within the DS3/E3 Framer block) is configured to operate in the Local-Timing/TxDS3FP Mode:</p> <p>This pin will function as a Framing Reference Input pin. In this mode, the user is expected to pulse this input pin "High" for one DS3 or E3 bit-period, coincident with the first bit of a given DS3 or E3 frame, being placed on the DS3/E3/STS1_DATA_IN_10 input pin. The Frame Generator block (associated with Channel 10) will synchronize its generation of DS3 or E3 frames to these framing pulses applied to this input pin.</p> <p>NOTE: This pin is inactive if the Frame Generator block, associated with Channel 10 is by-passed.</p>

STS-3/STM-1 TELECOM BUS INTERFACE - TRANSMIT DIRECTION

PIN #	SIGNAL NAME	I/O	SIGNAL TYPE	DESCRIPTION
AF17	STS3TxA_C1J1_3 TxDS3FP_11 TxSTS1PL_11 TxSBFrame_3	I/O	TTL/ CMOS	<p>STS-3/STM-1 Transmit Telecom Bus C1/J1 Byte Phase Indicator Input Signal (Channel 3); DS3/E3 Frame Generator Framing Pulse Input/Output Pin - Channel 11:</p> <p>The function of this pin depends upon whether or not the STS-3/STM-1 Telecom Bus Interface for Channel 11 has been enabled.</p> <p>If STS-3/STM-1 Telecom Bus (Channel 3) has been enabled - STS-3/STM-1 Transmit Telecom Bus C1/J1 Byte Phase Indicator Input Signal (Channel 3):</p> <p>This input pin should be pulsed "High" during both of the following conditions.</p> <ol style="list-style-type: none"> 1. Whenever the C1 byte is being input to the STS-3/STM-1 Transmit Telecom Bus (TXA_D_3[7:0]) input pins. 2. Whenever the J1 byte is being input to the STS-3/STM-1 Transmit Telecom Bus (TXA_D_3[7:0]) input pins. <p>If STS-3/STM-1 Telecom Bus (Channel 3) is disabled - TxDS3FP_11 (Transmit DS3 Frame Pulse Input/Output - Channel 11):</p> <p>If the STS-3/STM-1 Telecom Bus (Channel 3) is disabled and if the DS3/E3 Framer block is enabled then this pin will function as either a Transmit Framing Reference input pin or as a Transmit Framing Reference output pin.</p> <p>If the Frame Generator (within the DS3/E3 Framer block) is configured to operate in the Loop-Timing or in the Local-Timing/Asynchronous Framing Mode:</p> <p>This pin will function as a Framing Reference Output pin. The Frame Generator block (associated with Channel 11) will pulse this output pin "High" for one DS3/E3 bit-period, one period prior to the first bit of a given DS3 or E3 frame being applied to the DS3/E3/STS1_DATA_IN_11 input pin.</p> <p>If the Frame Generator (within the DS3/E3 Framer block) is configured to operate in the Local-Timing/TxDS3FP Mode:</p> <p>This pin will function as a Framing Reference Input pin. In this mode, the user is expected to pulse this input pin "High" for one DS3 or E3 bit-period, coincident with the first bit of a given DS3 or E3 frame, being placed on the DS3/E3/STS1_DATA_IN_11 input pin. The Frame Generator block (associated with Channel 11) will synchronize its generation of DS3 or E3 frames to these framing pulses applied to this input pin.</p> <p>NOTE: This pin is inactive if the Frame Generator block, associated with Channel 11 is by-passed.</p>

STS-3/STM-1 TELECOM BUS INTERFACE - TRANSMIT DIRECTION

PIN #	SIGNAL NAME	I/O	SIGNAL TYPE	DESCRIPTION
B22	STS3TxA_DP_0 TxDS3FP_4 TxSTS1PL_4	I/O	TTL/ CMOS	<p>STS-3/STM-1 Transmit Telecom Bus - Parity Input Pin - Channel 0; DS3/E3 Frame Generator Framing Pulse Input/Output Pin - Channel 4:</p> <p>The function of this pin depends upon whether or not the STS-3/STM-1 Telecom Bus Interface for Channel 0 has been enabled.</p> <p>If STS-3/STM-1 Telecom Bus (Channel 0) has been enabled - STS-3/STM-1 Transmit Telecom Bus - Parity Input Pin:</p> <p>This input pin can be configured to function as one of the following.</p> <ol style="list-style-type: none"> 1. The EVEN or ODD parity value of the bits which are input via the ST3TXA_D_0[7:0] input pins. 2. The EVEN or ODD parity value of the bits which are being input via the STS3TXA_D_0[7:0] input and the states of the STS3TXA_PL_0 and STS3TXA_C1J1_0 input pins. <p>NOTE: Any one of these configuration selections can be made by writing the appropriate value into the Interface Control Register - Byte 0 register (Indirect Address = 0x00, 0x3B), (Direct Address = 0x013B).</p> <p>If STS-3/STM-1 Telecom Bus (Channel 0) is disabled - TxDS3FP_4 (Transmit DS3 Frame Pulse Input/Output - Channel 4):</p> <p>If the STS-3/STM-1 Telecom Bus (Channel 0) is disabled and if the DS3/E3 Framer block is enabled then this pin will function as either a Transmit Framing Reference input pin or as a Transmit Framing Reference output pin.</p> <p>If the Frame Generator (within the DS3/E3 Framer block) is configured to operate in the Loop-Timing or in the Local-Timing/Asynchronous Framing Mode:</p> <p>This pin will function as a Framing Reference Output pin. The Frame Generator block (associated with Channel 4) will pulse this output pin "High" for one DS3/E3 bit-period, one period prior to the first bit of a given DS3 or E3 frame being applied to the DS3/E3/STS1_DATA_IN_4 input pin.</p> <p>If the Frame Generator (within the DS3/E3 Framer block) is configured to operate in the Local-Timing/TxDS3FP Mode:</p> <p>This pin will function as a Framing Reference Input pin. In this mode, the user is expected to pulse this input pin "High" for one DS3 or E3 bit-period, coincident with the first bit of a given DS3 or E3 frame, being placed on the DS3/E3/STS1_DATA_IN_4 input pin. The Frame Generator block (associated with Channel 4) will synchronize its generation of DS3 or E3 frames to these framing pulses applied to this input pin.</p> <p>NOTE: This pin is inactive if the Frame Generator block, associated with Channel 4 is by-passed.</p>

STS-3/STM-1 TELECOM BUS INTERFACE - TRANSMIT DIRECTION

PIN #	SIGNAL NAME	I/O	SIGNAL TYPE	DESCRIPTION
G23	STS3TxA_DP_1 TxDS3FP_5 TxSTS1PL_5	I/O	TTL/ CMOS	<p>STS-3/STM-1 Transmit Telecom Bus - Parity Input Pin - Channel 1, DS3/E3 Frame Generator Framing Pulse Input/Output Pin - Channel 5:</p> <p>If STS-3/STM-1 Telecom Bus (Channel 1) has been enabled - STS-3/STM-1 Transmit Telecom Bus - Parity Input Pin:</p> <p>This input pin can be configured to function as one of the following.</p> <ol style="list-style-type: none"> 1. The EVEN or ODD parity value of the bits which are input via the ST3TXA_D_1[7:0] input pins. 2. The EVEN or ODD parity value of the bits which are being input via the STS3TXA_D_1[7:0] input and the states of the STS3TXA_PL_1 and STS3TXA_C1J1_1 input pins. <p>NOTE: Any one of these configuration selections can be made by writing the appropriate value into the Interface Control Register - Byte 1 register (Indirect Address = 0x00, 0x3A), (Direct Address = 0x013A).</p> <p>If STS-3/STM-1 Telecom Bus (Channel 1) is disabled - TxDS3FP_5 (Transmit DS3 Frame Pulse Input/Output - Channel 5):</p> <p>If the STS-3/STM-1 Telecom Bus (Channel 1) is disabled and if the DS3/E3 Framer block is enabled then this pin will function as either a Transmit Framing Reference input pin or as a Transmit Framing Reference output pin.</p> <p>If the Frame Generator (within the DS3/E3 Framer block) is configured to operate in the Loop-Timing or in the Local-Timing/Asynchronous Framing Mode:</p> <p>This pin will function as a Framing Reference Output pin. The Frame Generator block (associated with Channel 5) will pulse this output pin "High" for one DS3/E3 bit-period, one period prior to the first bit of a given DS3 or E3 frame being applied to the DS3/E3/STS1_DATA_IN_5 input pin.</p> <p>If the Frame Generator (within the DS3/E3 Framer block) is configured to operate in the Local-Timing/TxDS3FP Mode:</p> <p>This pin will function as a Framing Reference Input pin. In this mode, the user is expected to pulse this input pin "High" for one DS3 or E3 bit-period, coincident with the first bit of a given DS3 or E3 frame, being placed on the DS3/E3/STS1_DATA_IN_5 input pin. The Frame Generator block (associated with Channel 5) will synchronize its generation of DS3 or E3 frames to these framing pulses applied to this input pin.</p> <p>NOTE: This pin is inactive if the Frame Generator block, associated with Channel 5 is by-passed.</p>

STS-3/STM-1 TELECOM BUS INTERFACE - TRANSMIT DIRECTION

PIN #	SIGNAL NAME	I/O	SIGNAL TYPE	DESCRIPTION
AE24	STS3TxA_DP_2 TxDS3FP_6 TxSTS1PL_6	I/O	TTL/ CMOS	<p>STS-3/STM-1 Transmit Telecom Bus - Parity Input Pin - Channel 2, DS3/E3 Frame Generator Framing Pulse Input/Output Pin - Channel 6:</p> <p>The function of this pin depends upon whether or not the STS-3/STM-1 Telecom Bus Interface for Channel 2 has been enabled.</p> <p>If STS-3/STM-1 Telecom Bus (Channel 2) has been enabled - STS-3/STM-1 Transmit Telecom Bus - Parity Input Pin:</p> <p>This input pin can be configured to function as one of the following.</p> <ol style="list-style-type: none"> 1. The EVEN or ODD parity value of the bits which are input via the ST3TXA_D_2[7:0] input pins. 2. The EVEN or ODD parity value of the bits which are being input via the STS3TXA_D_2[7:0] input and the states of the STS3TXA_PL_2 and STS3TXA_C1J1_2 input pins. <p>NOTE: Any one of these configuration selections can be made by writing the appropriate value into the Interface Control Register - Byte 2 register (Indirect Address = 0x00, 0x39), (Direct Address = 0x0139).</p> <p>If STS-3/STM-1 Telecom Bus (Channel 2) is disabled - TxDS3FP_6 (Transmit DS3 Frame Pulse Input/Output - Channel 6):</p> <p>If the STS-3/STM-1 Telecom Bus (Channel 2) is disabled and if the DS3/E3 Framer block is enabled then this pin will function as either a Transmit Framing Reference input pin or as a Transmit Framing Reference output pin.</p> <p>If the Frame Generator (within the DS3/E3 Framer block) is configured to operate in the Loop-Timing or in the Local-Timing/Asynchronous Framing Mode:</p> <p>This pin will function as a Framing Reference Output pin. The Frame Generator block (associated with Channel 6) will pulse this output pin "High" for one DS3/E3 bit-period, one period prior to the first bit of a given DS3 or E3 frame being applied to the DS3/E3/STS1_DATA_IN_6 input pin.</p> <p>If the Frame Generator (within the DS3/E3 Framer block) is configured to operate in the Local-Timing/TxDS3FP Mode:</p> <p>This pin will function as a Framing Reference Input pin. In this mode, the user is expected to pulse this input pin "High" for one DS3 or E3 bit-period, coincident with the first bit of a given DS3 or E3 frame, being placed on the DS3/E3/STS1_DATA_IN_6 input pin. The Frame Generator block (associated with Channel 6) will synchronize its generation of DS3 or E3 frames to these framing pulses applied to this input pin.</p> <p>NOTE: This pin is inactive if the Frame Generator block, associated with Channel 6 is by-passed.</p>

STS-3/STM-1 TELECOM BUS INTERFACE - TRANSMIT DIRECTION

PIN #	SIGNAL NAME	I/O	SIGNAL TYPE	DESCRIPTION
AE19	STS3TxA_DP_3 TxDS3FP_7 TxSTS1PL_7	I/O	TTL/ CMOS	<p>STS-3/STM-1 Transmit Telecom Bus - Parity Input Pin - Channel 3; DS3/E3 Frame Generator Framing Pulse Input/Output Pin - Channel 7:</p> <p>The function of this pin depends upon whether or not the STS-3/STM-1 Telecom Bus Interface for Channel 3 has been enabled.</p> <p>If STS-3/STM-1 Telecom Bus (Channel 3) has been enabled - STS-3/STM-1 Transmit Telecom Bus - Parity Input Pin:</p> <p>This input pin can be configured to function as one of the following.</p> <ol style="list-style-type: none"> 1. The EVEN or ODD parity value of the bits which are input via the ST3TXA_D_3[7:0] input pins. 2. The EVEN or ODD parity value of the bits which are being input via the STS3TXA_D_3[7:0] input and the states of the STS3TXA_PL_3 and STS3TXA_C1J1_3 input pins. <p>NOTE: Any one of these configuration selections can be made by writing the appropriate value into the Interface Control Register - Byte 3 register (Indirect Address = 0x00, 0x38), (Direct Address = 0x0138).</p> <p>If STS-3/STM-1 Telecom Bus (Channel 0) is disabled - TxDS3FP_7 (Transmit DS3 Frame Pulse Input/Output - Channel 7):</p> <p>If the STS-3/STM-1 Telecom Bus (Channel 3) is disabled and if the DS3/E3 Framer block is enabled then this pin will function as either a Transmit Framing Reference input pin or as a Transmit Framing Reference output pin.</p> <p>If the Frame Generator (within the DS3/E3 Framer block) is configured to operate in the Loop-Timing or in the Local-Timing/Asynchronous Framing Mode:</p> <p>This pin will function as a Framing Reference Output pin. The Frame Generator block (associated with Channel 7) will pulse this output pin "High" for one DS3/E3 bit-period, one period prior to the first bit of a given DS3 or E3 frame being applied to the DS3/E3/STS1_DATA_IN_7 input pin.</p> <p>If the Frame Generator (within the DS3/E3 Framer block) is configured to operate in the Local-Timing/TxDS3FP Mode:</p> <p>This pin will function as a Framing Reference Input pin. In this mode, the user is expected to pulse this input pin "High" for one DS3 or E3 bit-period, coincident with the first bit of a given DS3 or E3 frame, being placed on the DS3/E3/STS1_DATA_IN_7 input pin. The Frame Generator block (associated with Channel 7) will synchronize its generation of DS3 or E3 frames to these framing pulses applied to this input pin.</p> <p>NOTE: This pin is inactive if the Frame Generator block, associated with Channel 7 is by-passed.</p>

STS-3/STM-1 TELECOM BUS INTERFACE - TRANSMIT DIRECTION

PIN #	SIGNAL NAME	I/O	SIGNAL TYPE	DESCRIPTION
B18	STS3TxA_ALARM_0 TxDS3FP_0 TxSTS1PL_0	I/O	TTL/ CMOS	<p>Transmit STS-3/STM-1 Telecom Bus - Alarm Indicator Input - Channel 0; DS3/E3 Frame Generator Framing Pulse Input/Output Pin - Channel 0:</p> <p>The function of this pin depends upon whether or not the STS-3/STM-1 Telecom Bus Interface for Channel 0 has been enabled.</p> <p>If STS-3/STM-1 Telecom Bus (Channel 0) has been enabled - STS-3/STM-1 Transmit Telecom Bus - Alarm Indicator Input:</p> <p>This input pin pulses "High" coincident to any STS-1 signal (which is carrying the AIS-P indicator) being applied to the STS3TxA_D_0[7:0] input data bus.</p> <p><i>NOTE: If the STS3TXA_ALARM_0 input signal pulses "High" for any given STS-1 signal (within the incoming STS-3), then the XRT94L43 will automatically declare an AIS-P for that STS-1 channel.</i></p> <p>If STS-3/STM-1 Telecom Bus (Channel 0) is disabled - TxDS3FP_0 (Transmit DS3 Frame Pulse Input/Output - Channel 0):</p> <p>If the STS-3/STM-1 Telecom Bus (Channel 0) is disabled and if the DS3/E3 Framer block is enabled then this pin will function as either a Transmit Framing Reference input pin or as a Transmit Framing Reference output pin.</p> <p>If the Frame Generator (within the DS3/E3 Framer block) is configured to operate in the Loop-Timing or in the Local-Timing/Asynchronous Framing Mode:</p> <p>This pin will function as a Framing Reference Output pin. The Frame Generator block (associated with Channel 0) will pulse this output pin "High" for one DS3/E3 bit-period, one period prior to the first bit of a given DS3 or E3 frame being applied to the DS3/E3/STS1_DATA_IN_0 input pin.</p> <p>If the Frame Generator (within the DS3/E3 Framer block) is configured to operate in the Local-Timing/TxDS3FP Mode:</p> <p>This pin will function as a Framing Reference Input pin. In this mode, the user is expected to pulse this input pin "High" for one DS3 or E3 bit-period, coincident with the first bit of a given DS3 or E3 frame, being placed on the DS3/E3/STS1_DATA_IN_0 input pin. The Frame Generator block (associated with Channel 0) will synchronize its generation of DS3 or E3 frames to these framing pulses applied to this input pin.</p> <p><i>NOTE: This pin is inactive if the Frame Generator block, associated with Channel 0 is by-passed.</i></p>

STS-3/STM-1 TELECOM BUS INTERFACE - TRANSMIT DIRECTION

PIN #	SIGNAL NAME	I/O	SIGNAL TYPE	DESCRIPTION
D25	STS3TxA_ALARM_1 TxDS3FP_1 TxSTS1PL_1	I/O	TTL/ CMOS	<p>Transmit STS-3/STM-1 Telecom Bus - Alarm Indicator Input - Channel 1; DS3/E3 Frame Generator Framing Pulse Input/Output Pin - Channel 1:</p> <p>The function of this pin depends upon whether or not the STS-3/STM-1 Telecom Bus Interface for Channel 1 has been enabled.</p> <p>If STS-3/STM-1 Telecom Bus (Channel 1) has been enabled - STS-3/STM-1 Transmit Telecom Bus - Alarm Indicator Input:</p> <p>This input pin pulses "High" coincident to any STS-1 signal (which is carrying the AIS-P indicator) being applied to the STS3TxA_D_1[7:0] input data bus.</p> <p>NOTE: <i>If the STS3TxA_ALARM_1 input signal pulses "High" for any given STS-1 signal (within the incoming STS-3), then the XRT94L43 will automatically declare an AIS-P for that STS-1 channel.</i></p> <p>If STS-3/STM-1 Telecom Bus (Channel 1) is disabled - TxDS3FP_1 (Transmit DS3 Frame Pulse Input/Output - Channel 1):</p> <p>If the STS-3/STM-1 Telecom Bus (Channel 1) is disabled and if the DS3/E3 Framer block is enabled then this pin will function as either a Transmit Framing Reference input pin or as a Transmit Framing Reference output pin.</p> <p>If the Frame Generator (within the DS3/E3 Framer block) is configured to operate in the Loop-Timing or in the Local-Timing/Asynchronous Framing Mode:</p> <p>This pin will function as a Framing Reference Output pin. The Frame Generator block (associated with Channel 1) will pulse this output pin "High" for one DS3/E3 bit-period, one period prior to the first bit of a given DS3 or E3 frame being applied to the DS3/E3/STS1_DATA_IN_1 input pin.</p> <p>If the Frame Generator (within the DS3/E3 Framer block) is configured to operate in the Local-Timing/TxDS3FP Mode:</p> <p>This pin will function as a Framing Reference Input pin. In this mode, the user is expected to pulse this input pin "High" for one DS3 or E3 bit-period, coincident with the first bit of a given DS3 or E3 frame, being placed on the DS3/E3/STS1_DATA_IN_1 input pin. The Frame Generator block (associated with Channel 1) will synchronize its generation of DS3 or E3 frames to these framing pulses applied to this input pin.</p> <p>NOTE: <i>This pin is inactive if the Frame Generator block, associated with Channel 1 is by-passed.</i></p>

STS-3/STM-1 TELECOM BUS INTERFACE - TRANSMIT DIRECTION

PIN #	SIGNAL NAME	I/O	SIGNAL TYPE	DESCRIPTION
AB26	STS3TxA_ALARM_2 TxDS3FP_2 TxSTS1PL_2	I/O	TTL/ CMOS	<p>Transmit STS-3/STM-1 Telecom Bus - Alarm Indicator Input - Channel 2; DS3/E3 Frame Generator Framing Pulse Input/Output Pin - Channel 2:</p> <p>The function of this pin depends upon whether or not the STS-3/STM-1 Telecom Bus Interface for Channel 2 has been enabled.</p> <p>If STS-3/STM-1 Telecom Bus (Channel 2) has been enabled - STS-3/STM-1 Transmit Telecom Bus - Alarm Indicator Input:</p> <p>This input pin pulses "High" coincident to any STS-1 signal (which is carrying the AIS-P indicator) being applied to the STS3TxA_D_2[7:0] input data bus.</p> <p><i>NOTE: If the STS3TxA_ALARM_2 input signal pulses "High" for any given STS-1 signal (within the incoming STS-3), then the XRT94L43 will automatically declare an AIS-P for that STS-1 channel.</i></p> <p>If STS-3/STM-1 Telecom Bus (Channel 2) is disabled - TxDS3FP_2 (Transmit DS3 Frame Pulse Input/Output - Channel 2):</p> <p>If the STS-3/STM-1 Telecom Bus (Channel 2) is disabled and if the DS3/E3 Framer block is enabled then this pin will function as either a Transmit Framing Reference input pin or as a Transmit Framing Reference output pin.</p> <p>If the Frame Generator (within the DS3/E3 Framer block) is configured to operate in the Loop-Timing or in the Local-Timing/Asynchronous Framing Mode:</p> <p>This pin will function as a Framing Reference Output pin. The Frame Generator block (associated with Channel 2) will pulse this output pin "High" for one DS3/E3 bit-period, one period prior to the first bit of a given DS3 or E3 frame being applied to the DS3/E3/STS1_DATA_IN_2 input pin.</p> <p>If the Frame Generator (within the DS3/E3 Framer block) is configured to operate in the Local-Timing/TxDS3FP Mode:</p> <p>This pin will function as a Framing Reference Input pin. In this mode, the user is expected to pulse this input pin "High" for one DS3 or E3 bit-period, coincident with the first bit of a given DS3 or E3 frame, being placed on the DS3/E3/STS1_DATA_IN_2 input pin. The Frame Generator block (associated with Channel 2) will synchronize its generation of DS3 or E3 frames to these framing pulses applied to this input pin.</p> <p><i>NOTE: This pin is inactive if the Frame Generator block, associated with Channel 2 is by-passed.</i></p>

STS-3/STM-1 TELECOM BUS INTERFACE - TRANSMIT DIRECTION

PIN #	SIGNAL NAME	I/O	SIGNAL TYPE	DESCRIPTION
AF22	STS3TxA_ALARM_3 TxDS3FP_3 TxSTS1PL_3	I/O	TTL/ CMOS	<p>Transmit STS-3/STM-1 Telecom Bus - Alarm Indicator Input - Channel 3; DS3/E3 Frame Generator Framing Pulse Input/Output Pin - Channel 3:</p> <p>The function of this pin depends upon whether or not the STS-3/STM-1 Telecom Bus Interface for Channel 3 has been enabled.</p> <p>If STS-3/STM-1 Telecom Bus (Channel 3) has been enabled - STS-3/STM-1 Transmit Telecom Bus - Alarm Indicator Input:</p> <p>This input pin pulses "High" coincident to any STS-1 signal (which is carrying the AIS-P indicator) being applied to the STS3TxA_D_3[7:0] input data bus.</p> <p><i>NOTE: If the STS3TxA_ALARM_3 input signal pulses "High" for any given STS-1 signal (within the incoming STS-3), then the XRT94L43 will automatically declare an AIS-P for that STS-1 channel.</i></p> <p>If STS-3/STM-1 Telecom Bus (Channel 3) is disabled - TxDS3FP_3 (Transmit DS3 Frame Pulse Input/Output - Channel 3):</p> <p>If the STS-3/STM-1 Telecom Bus (Channel 3) is disabled and if the DS3/E3 Framer block is enabled then this pin will function as either a Transmit Framing Reference input pin or as a Transmit Framing Reference output pin.</p> <p>If the Frame Generator (within the DS3/E3 Framer block) is configured to operate in the Loop-Timing or in the Local-Timing/Asynchronous Framing Mode:</p> <p>This pin will function as a Framing Reference Output pin. The Frame Generator block (associated with Channel 3) will pulse this output pin "High" for one DS3/E3 bit-period, one period prior to the first bit of a given DS3 or E3 frame being applied to the DS3/E3/STS1_DATA_IN_3 input pin.</p> <p>If the Frame Generator (within the DS3/E3 Framer block) is configured to operate in the Local-Timing/TxDS3FP Mode:</p> <p>This pin will function as a Framing Reference Input pin. In this mode, the user is expected to pulse this input pin "High" for one DS3 or E3 bit-period, coincident with the first bit of a given DS3 or E3 frame, being placed on the DS3/E3/STS1_DATA_IN_3 input pin. The Frame Generator block (associated with Channel 3) will synchronize its generation of DS3 or E3 frames to these framing pulses applied to this input pin.</p> <p><i>NOTE: This pin is inactive if the Frame Generator block, associated with Channel 3 is by-passed.</i></p>

STS-3/STM-1 TELECOM BUS INTERFACE - TRANSMIT DIRECTION

PIN #	SIGNAL NAME	I/O	SIGNAL TYPE	DESCRIPTION
C15	STS3TxA_D_0_0 TxSBDATA_0 RLOOP_0	I/O	TTL/ CMOS	<p>Transmit STS-3/STM-1 Telecom Bus - Channel 0 - Input Data Bus Pin Number 0/RLOOP_0 (General Purpose) output pin:</p> <p>The function of this pin depends upon whether or not the STS-3/STM-1 Telecom Bus Interface, associated with Channel 0 is enabled.</p> <p>If STS-3/STM-1 Telecom Bus (Channel 0) has been enabled - STS-3/STM-1 Transmit Telecom Bus - Input Data Bus Pin Number 0:</p> <p>This input pin along with STS3TxA_D_0[7:1] function as the STS-3/STM-1 Transmit (Add) Telecom Bus - Input Data Bus for Channel 0. This input pin functions as the LSB (Least Significant Bit) input pin on the Transmit (Add) Telecom Bus - Input Data Bus. The STS-3/STM-1 Telecom Bus interface will sample and latch this pin upon the falling edge of STS3TxA_CLK_0. The LSB of any byte, which is being input into the STS-3/STM-1 Transmit Telecom Bus - Data Bus (for Channel 0) should be input via this pin.</p> <p>If STS-3/STM-1 Telecom Bus (Channel 0) is disabled - RLOOP_0 (General Purpose) output Pin:</p> <p>This output pin can be used as a general purpose output pin. The state of this output pin can be controlled by writing the appropriate value into Bit 1 (RLOOP) within the Line Interface Drive Register associated with Channel 0 (Indirect Address = 0x1E, 0x80), (Direct Address = 0x1F80).</p> <p>NOTE: For Product Legacy purposes, this pin is called RLOOP_0 because one possible application is to tie this output pin to an RLOOP (Remote Loop-back) input pin from one of Exar's XRT73L0X/XRT75L0X DS3/E3/STS-1 LIU devices. However, this output pin, and the corresponding register bit can be used for any purpose.</p>

STS-3/STM-1 TELECOM BUS INTERFACE - TRANSMIT DIRECTION

PIN #	SIGNAL NAME	I/O	SIGNAL TYPE	DESCRIPTION
C16	STS3TxA_D_0_1 TxSBDATA_1 REQ_0	I/O	TTL/ CMOS	<p>Transmit STS-3/STM-1 Telecom Bus - Channel 0 - Input Data Bus Pin Number 0/REQ_0 (General Purpose) output Pin:</p> <p>The function of this pin depends upon whether or not the STS-3/STM-1 Telecom Bus Interface, associated with Channel 0 is enabled.</p> <p>If STS-3/STM-1 Telecom Bus (Channel 0) has been enabled - STS-3/STM-1 Transmit Telecom Bus - Input Data Bus Pin Number 1:</p> <p>This input pin along with STS3TxA_D_0[7:2] and STS3TxA_D_0_0 function as the STS-3/STM-1 Transmit (Add) Telecom Bus - Input Data Bus for Channel 0. The STS-3/STM-1 Telecom Bus interface will sample and latch this pin upon the falling edge of STS3TxA_CLK_0.</p> <p>If STS-3/STM-1 Telecom Bus (Channel 0) is disabled - REQ_0 (General Purpose) output pin.</p> <p>This output pin can be used as a general purpose output pin. The state of this output pin can be controlled by writing the appropriate value into Bit 5 (REQB) within the Line Interface Drive Register associated with Channel 0 (Indirect Address = 0x1E, 0x80), (Direct Address = 0x1F01).</p> <p>NOTE: For Product Legacy purposes, this pin is called REQ_0 because one possible application is to tie this output pin to an REQB (Receive Equalizer By-Pass) or REQEN (Receive Equalizer Enable) input pin from one of Exar's XRT73L0X/ XRT75L0X DS3/E3/STS-1 LIU devices. However, this output pin, and the corresponding register bit can be used for any purpose.</p>

STS-3/STM-1 TELECOM BUS INTERFACE - TRANSMIT DIRECTION

PIN #	SIGNAL NAME	I/O	SIGNAL TYPE	DESCRIPTION
B19	STS3TxA_D_0_2 TxSBDATA_2 DS3/E3/ STS1_DATA_IN_0	I	TTL	<p>Transmit STS-3/STM-1 Telecom Bus - Channel 0 - Input Data Bus Pin Number 2/DS3/E3 Framer or Receive STS-1 TOH Processor block line interface input Pin - Channel 0:</p> <p>The function of this pin depends upon whether or not the STS-3/STM-1 Telecom Bus Interface, associated with Channel 0 is enabled.</p> <p>If STS-3/STM-1 Telecom Bus (Channel 0) has been enabled - STS-3/STM-1 Transmit Telecom Bus - Input Data Bus Pin Number 2:</p> <p>STS3TxA_D_0_2 This input pin along with STS3TxA_D_0[7:3] and STS3TxA_D_0[1:0] function as the STS-3/STM-1 Transmit (Add) Telecom Bus - Input Data Bus for Channel 0. The STS-3/STM-1 Telecom Bus interface will sample and latch this pin upon the falling edge of STS3TxA_CLK_0.</p> <p>If STS-3/STM-1 Telecom Bus (Channel 0) is disabled - DS3/E3/STS1_DATA_IN - DS3/E3/STS-1 Line Interface Data Input - Channel 0:</p> <p>This input accepts single-rail, recovered DS3, E3 or STS-1 data (from a DS3/E3/STS-1 LIU IC). This input pin should be connected to the RPOS output of the DS3/E3/STS-1 LIU IC (corresponding to channel 0).</p> <p>By default, the data that is applied to this input pin will be latched into the XRT94L43 upon the falling edge of the DS3/E3/STS1_CLK_IN_0 signal pin number F15.</p> <p>For DS3/E3 Applications</p> <p>The XRT94L43 can be configured to latch this input signal upon the rising edge of the DS3/E3/STS1_CLK_IN_0 signal by setting Bit 1 (DS3/E3/STS1_CLK_IN Invert), within the I/O Control Register - Channel 0 (Indirect Address = 0x1E, 0x01), (Direct Address = 0x1F01) to a "1".</p> <p>For STS-1 Applications</p> <p>The XRT94L43 can not be configured to sample the DS3/E3/STS1_DATA_IN_0 signal upon the rising edge of DS3/E3/STS1_CLK_IN_0.</p>

STS-3/STM-1 TELECOM BUS INTERFACE - TRANSMIT DIRECTION

PIN #	SIGNAL NAME	I/O	SIGNAL TYPE	DESCRIPTION
B23	STS3TxA_D_0_3 TxSBDATA_3 DS3/E3/ STS1_DATA_IN_4	I	TTL	<p>Transmit STS-3/STM-1 Telecom Bus - Channel 0 - Input Data Bus Pin Number 3/DS3/E3 Framer or Receive STS-1 TOH Processor block line interface input Pin - Channel 4:</p> <p>The function of this pin depends upon whether or not the STS-3/STM-1 Telecom Bus Interface, associated with Channel 0 is enabled.</p> <p>If STS-3/STM-1 Telecom Bus (Channel 0) has been enabled - STS-3/STM-1 Transmit Telecom Bus - Input Data Bus Pin Number 2: STS3TxA_D_0_3:</p> <p>This input pin along with STS3TxA_D_0[7:4] and STS3TxA_D_0[2:0] function as the STS-3/STM-1 Transmit (Add) Telecom Bus - Input Data Bus for Channel 0. The STS-3/STM-1 Telecom Bus interface will sample and latch this pin upon the falling edge of STS3TxA_CLK_0.</p> <p>If STS-3/STM-1 Telecom Bus (Channel 0) is disabled - DS3/E3/STS1_DATA_IN - DS3/E3/STS-1 Line Interface Data Input - Channel 4:</p> <p>This input accepts single-rail, recovered DS3, E3 or STS-1 data (from a DS3/E3/STS-1 LIU IC). This input pin should be connected to the RPOS output of the DS3/E3/STS-1 LIU IC (corresponding to channel 4).</p> <p>By default, the data that is applied to this input pin will be latched into the XRT94L43 upon the falling edge of the DS3/E3/STS1_CLK_IN_4 signal pin number A22.</p> <p>For DS3/E3 Applications</p> <p>The XRT94L43 can be configured to latch this input signal upon the rising edge of the DS3/E3/STS1_CLK_IN_4 signal by setting Bit 1 (DS3/E3/STS1_CLK_IN Invert), within the I/O Control Register - Channel 4 (Indirect Address = 0x5E, 0x01), (Direct Address = 0x5F01) to a "1".</p> <p>For STS-1 Applications</p> <p>The XRT94L43 can not be configured to sample the DS3/E3/STS1_DATA_IN_4 signal upon the rising edge of DS3/E3/STS1_CLK_IN_4.</p>

STS-3/STM-1 TELECOM BUS INTERFACE - TRANSMIT DIRECTION

PIN #	SIGNAL NAME	I/O	SIGNAL TYPE	DESCRIPTION
B25	STS3TxA_D_0_4 TxSBDATA_4 DS3/E3/ STS1_DATA_IN_8	I	TTL	<p>Transmit STS-3/STM-1 Telecom Bus - Channel 0 - Input Data Bus Pin Number 3/DS3/E3 Framer or Receive STS-1 TOH Processor block line interface input Pin - Channel 4:</p> <p>The function of this pin depends upon whether or not the STS-3/STM-1 Telecom Bus Interface, associated with Channel 0 is enabled.</p> <p>If STS-3/STM-1 Telecom Bus (Channel 0) has been enabled - STS-3/STM-1 Transmit Telecom Bus - Input Data Bus Pin Number 4: STS3TxA_D_0_4:</p> <p>This input pin along with STS3TxA_D_0[7:5] and STS3TxA_D_0[3:0] function as the STS-3/STM-1 Transmit (Add) Telecom Bus - Input Data Bus for Channel 0. The STS-3/STM-1 Telecom Bus interface will sample and latch this pin upon the falling edge of STS3TxA_CLK_0.</p> <p>If STS-3/STM-1 Telecom Bus (Channel 0) is disabled - DS3/E3/STS1_DATA_IN - DS3/E3/STS-1 Line Interface Data Input - Channel 8:</p> <p>This input accepts single-rail, recovered DS3, E3 or STS-1 data (from a DS3/E3/STS-1 LIU IC). This input pin should be connected to the RPOS output of the DS3/E3/STS-1 LIU IC (corresponding to channel 8).</p> <p>By default, the data that is applied to this input pin will be latched into the XRT94L43 upon the falling edge of the DS3/E3/STS1_CLK_IN_8 signal pin number A24.</p> <p>For DS3/E3 Applications</p> <p>The XRT94L43 can be configured to latch this input signal upon the rising edge of the DS3/E3/STS1_CLK_IN_8 signal by setting Bit 1 (DS3/E3/STS1_CLK_IN Invert), within the I/O Control Register - Channel 8 (Indirect Address = 0x9E, 0x01), (Direct Address = 0x9F01) to a "1".</p> <p>For STS-1 Applications:</p> <p>The XRT94L43 can not be configured to sample the DS3/E3/STS1_DATA_IN_8 signal upon the rising edge of Ds3/E3/STS1_CLK_IN_8.</p>

STS-3/STM-1 TELECOM BUS INTERFACE - TRANSMIT DIRECTION

PIN #	SIGNAL NAME	I/O	SIGNAL TYPE	DESCRIPTION
F15	STS3TxA_D_0_5 TxSBDATA_5 DS3/E3/ STS1_CLK_IN_0	I	TTL	<p>Transmit STS-3/STM-1 Telecom Bus - Channel 0 - Input Data Bus Pin Number 5/DS3/E3 Framer or Receive STS-1 TOH Processor block line interface clock input Pin - Channel 0:</p> <p>The function of this pin depends upon whether or not the STS-3/STM-1 Telecom Bus Interface, associated with Channel 0 is enabled.</p> <p>If STS-3/STM-1 Telecom Bus (Channel 0) has been enabled - STS-3/STM-1 Transmit Telecom Bus - Input Data Bus Pin Number 5: STS3TxA_D_0_5:</p> <p>This input pin along with STS3TxA_D_0[7:6] and STS3TxA_D_0[4:0] function as the STS-3/STM-1 Transmit (Add) Telecom Bus - Input Data Bus for Channel 0. The STS-3/STM-1 Telecom Bus interface will sample and latch this pin upon the falling edge of STS3TxA_CLK_0.</p> <p>If STS-3/STM-1 Telecom Bus (Channel 0) is disabled - DS3/E3/STS1_CLK_IN - DS3/E3/STS-1 Line Interface Clock Input - Channel 0:</p> <p>This input accepts a recovered DS3, E3 or STS-1 clock signal (from a DS3/E3/STS-1 LIU IC). This input pin should be connected to the RCLK output of the DS3/E3/STS-1 LIU IC (corresponding to channel 0).</p> <p>The XRT94L43 uses this clock signal to sample and latch the data that is applied to the DS3/E3/STS1_DATA_IN_0 input pin number B19.</p> <p>By default, the data that is applied to the DS3/E3/STS1_DATA_IN_0 input pin will be latched into the XRT94L43 upon the falling edge of this clock signal.</p> <p>For DS3/E3 Applications</p> <p>The XRT94L43 can be configured to latch the DS3/E3/STS1_DATA_IN_0 signal upon the rising edge of this clock signal by setting Bit 1 (DS3/E3/STS1_CLK_IN Invert), within the I/O Control Register - Channel 0 (Indirect Address = 0x1E, 0x01), (Direct Address = 0x1F01) to a "1".</p> <p>For STS-1 Applications</p> <p>The XRT94L43 can not be configured to sample the DS3/E3/STS1_DATA_IN_0 signal upon the rising edge of this clock signal.</p>

STS-3/STM-1 TELECOM BUS INTERFACE - TRANSMIT DIRECTION

PIN #	SIGNAL NAME	I/O	SIGNAL TYPE	DESCRIPTION
A22	STS3TxA_D_0_6 TxSBDATA_6 DS3/E3/ STS1_CLK_IN_4	I	TTL	<p>Transmit STS-3/STM-1 Telecom Bus - Channel 0 - Input Data Bus Pin Number 6/DS3/E3 Framer or Receive STS-1 TOH Processor block line interface clock input Pin - Channel 4:</p> <p>The function of this pin depends upon whether or not the STS-3/STM-1 Telecom Bus Interface, associated with Channel 0 is enabled.</p> <p>If STS-3/STM-1 Telecom Bus (Channel 0) has been enabled - STS-3/STM-1 Transmit Telecom Bus - Input Data Bus Pin Number 6: STS3TxA_D_0_6:</p> <p>This input pin along with STS3TxA_D_0_7 and STS3TxA_D_0[5:0] function as the STS-3/STM-1 Transmit (Add) Telecom Bus - Input Data Bus for Channel 0. The STS-3/STM-1 Telecom Bus interface will sample and latch this pin upon the falling edge of STS3TxA_CLK_0.</p> <p>If STS-3/STM-1 Telecom Bus (Channel 0) is disabled - DS3/E3/STS1_CLK_IN - DS3/E3/STS-1 Line Interface Clock Input - Channel 4:</p> <p>This input accepts a recovered DS3, E3 or STS-1 clock signal (from a DS3/E3/STS-1 LIU IC). This input pin should be connected to the RCLK output of the DS3/E3/STS-1 LIU IC (corresponding to channel 4).</p> <p>The XRT94L43 uses this clock signal to sample and latch the data that is applied to the DS3/E3/STS1_DATA_IN_4 input pin number B23.</p> <p>By default, the data that is applied to the DS3/E3/STS1_DATA_IN_4 input pin will be latched into the XRT94L43 upon the falling edge of this clock signal.</p> <p>For DS3/E3 Applications</p> <p>The XRT94L43 can be configured to latch the DS3/E3/STS1_DATA_IN_4 signal upon the rising edge of this clock signal by setting Bit 1 (DS3/E3/STS1_CLK_IN Invert), within the I/O Control Register - Channel 4 (Indirect Address = 0x5E, 0x01), (Direct Address = 0x5F01) to a "1".</p> <p>For STS-1 Applications</p> <p>The XRT94L43 can not be configured to sample the DS3/E3/STS1_DATA_IN_4 signal upon the rising edge of this clock signal.</p>

STS-3/STM-1 TELECOM BUS INTERFACE - TRANSMIT DIRECTION

PIN #	SIGNAL NAME	I/O	SIGNAL TYPE	DESCRIPTION
A24	STS3TxA_D_0_7 TxSB_DATA_7 DS3/E3/ STS1_CLK_IN_8	I	TTL	<p>Transmit STS-3/STM-1 Telecom Bus - Channel 0 - Input Data Bus Pin Number 7/DS3/E3 Framer or Receive STS-1 TOH Processor block line interface clock input Pin - Channel 8:</p> <p>The function of this pin depends upon whether or not the STS-3/STM-1 Telecom Bus Interface, associated with Channel 0 is enabled.</p> <p>If STS-3/STM-1 Telecom Bus (Channel 0) has been enabled - STS-3/STM-1 Transmit Telecom Bus - Input Data Bus Pin Number 7: STS3TxA_D_0_7:</p> <p>This input pin along with STS3TxA_D_0[6:0] function as the STS-3/STM-1 Transmit (Add) Telecom Bus - Input Data Bus for Channel 0. The STS-3/STM-1 Telecom Bus interface will sample and latch this pin upon the falling edge of STS3TxA_CLK_0.</p> <p><i>NOTE: This input pin functions as the MSB (Most Significant Bit) of the Transmit (Add) Telecom Bus, for Channel 0.</i></p> <p>If STS-3/STM-1 Telecom Bus (Channel 0) is disabled - DS3/E3/STS1_CLK_IN - DS3/E3/STS-1 Line Interface Clock Input - Channel 8:</p> <p>This input accepts a recovered DS3, E3 or STS-1 clock signal (from a DS3/E3/STS-1 LIU IC). This input pin should be connected to the RCLK output of the DS3/E3/STS-1 LIU IC (corresponding to channel 8).</p> <p>The XRT94L43 uses this clock signal to sample and latch the data that is applied to the DS3/E3/STS1_DATA_IN_8 input pin number B25.</p> <p>By default, the data that is applied to the DS3/E3/STS1_DATA_IN_8 input pin will be latched into the XRT94L43 upon the falling edge of this clock signal.</p> <p>For DS3/E3 Applications</p> <p>The XRT94L43 can be configured to latch the DS3/E3/STS1_DATA_IN_8 signal upon the rising edge of this clock signal by setting Bit 1 (DS3/E3/STS1_CLK_IN Invert), within the I/O Control Register - Channel 8 (Indirect Address = 0x9E, 0x01), " (Direct Address = 0x9F01) to a "1".</p> <p>For STS-1 Applications</p> <p>The XRT94L43 can not be configured to sample the DS3/E3/STS1_DATA_IN_8 signal upon the rising edge of this clock signal.</p>

STS-3/STM-1 TELECOM BUS INTERFACE - TRANSMIT DIRECTION

PIN #	SIGNAL NAME	I/O	SIGNAL TYPE	DESCRIPTION
C25	STS3TxA_D_1_0 TxSBDATA_0 RLOOP_1	I/O	TTL	<p>Transmit STS-3/STM-1 Telecom Bus - Channel 1 - Input Data Bus Pin Number 0/RLOOP_1 (General Purpose) output Pin:</p> <p>The function of this pin depends upon whether or not the STS-3/STM-1 Telecom Bus Interface, associated with Channel 1 is enabled.</p> <p>If STS-3/STM-1 Telecom Bus (Channel 1) has been enabled - STS-3/STM-1 Transmit Telecom Bus - Input Data Bus Pin Number 0:</p> <p>This input pin along with STS3TxA_D_1[7:1] function as the STS-3/STM-1 Transmit (Add) Telecom Bus - Input Data Bus for Channel 1. This input pin functions as the LSB (Least Significant Bit) input pin on the Transmit (Add) Telecom Bus - Input Data Bus. The STS-3/STM-1 Telecom Bus interface will sample and latch this pin upon the falling edge of STS3TxA_CLK_1.</p> <p>The LSB of any byte, which is being input into the STS-3/STM-1 Transmit Telecom Bus - Data Bus (for Channel 1) should be input via this pin.</p> <p>If STS-3/STM-1 Telecom Bus (Channel 1) is disabled - RLOOP_1 (General Purpose) output Pin:</p> <p>This output pin can be used as a general purpose output pin.</p> <p>The state of this output pin can be controlled by writing the appropriate value into Bit 1 (RLOOP) within the Line Interface Drive Register associated with Channel 1 (Indirect Address = 0x2E, 0x80), (Direct Address = 0x2F80).</p> <p>NOTE: For Product Legacy purposes, this pin is called RLOOP_1 because one possible application is to tie this output pin to an RLOOP (Remote Loop-back) input pin from one of Exar's XRT73L0X/XRT75L0X DS3/E3/STS-1 LIU devices. However, this output pin, and the corresponding register bit can be used for any purpose.</p>

STS-3/STM-1 TELECOM BUS INTERFACE - TRANSMIT DIRECTION

PIN #	SIGNAL NAME	I/O	SIGNAL TYPE	DESCRIPTION
B26	STS3TxA_D_1_1 TxSBDATA_1 REQ_1	I/O	TTL	<p>Transmit STS-3/STM-1 Telecom Bus - Channel 1 - Input Data Bus Pin Number 1/REQ_1 (General Purpose) output Pin:</p> <p>The function of this pin depends upon whether or not the STS-3/STM-1 Telecom Bus Interface, associated with Channel 1 is enabled.</p> <p>If STS-3/STM-1 Telecom Bus (Channel 1) has been enabled - STS-3/STM-1 Transmit Telecom Bus - Input Data Bus Pin Number 1:</p> <p>This input pin along with STS3TxA_D_1[7:2] and STS3TxA_D_1_0 function as the STS-3/STM-1 Transmit (Add) Telecom Bus - Input Data Bus for Channel 1. The STS-3/STM-1 Telecom Bus interface will sample and latch this pin upon the falling edge of STS3TxA_CLK_1.</p> <p>If STS-3/STM-1 Telecom Bus (Channel 1) is disabled - REQ_1 (General Purpose) output Pin:</p> <p>This output pin can be used as a general purpose output pin. The state of this output pin can be controlled by writing the appropriate value into Bit 5 (REQB) within the Line Interface Drive Register associated with Channel 1 (Indirect Address = 0x2E, 0x80), (Direct Address = 0x2F80).</p> <p>NOTE: For Product Legacy purposes, this pin is called REQ_1 because one possible application is to tie this output pin to an REQB (Receive Equalizer By-Pass) or REQEN (Receive Equalizer Enable) input pin from one of Exar's XRT73L0X/ XRT75L0X DS3/E3/STS-1 LIU devices. However, this output pin, and the corresponding register bit can be used for any purpose.</p>

STS-3/STM-1 TELECOM BUS INTERFACE - TRANSMIT DIRECTION

PIN #	SIGNAL NAME	I/O	SIGNAL TYPE	DESCRIPTION
E26	STS3TxA_D_1_2 TxSBDATA_2 DS3/E3/ STS1_DATA_IN_1	I	TTL	<p>Transmit STS-3/STM-1 Telecom Bus - Channel 1 - Input Data Bus Pin Number 2/DS3/E3 Framer or Receive STS-1 TOH Processor block line interface input Pin - Channel 1:</p> <p>The function of this pin depends upon whether or not the STS-3/STM-1 Telecom Bus Interface, associated with Channel 1 is enabled.</p> <p>If STS-3/STM-1 Telecom Bus (Channel 1) has been enabled - STS-3/STM-1 Transmit Telecom Bus - Input Data Bus Pin Number 2: STS3TxA_D_1_2:</p> <p>This input pin along with STS3TxA_D_1[7:3] and STS3TxA_D_1[1:0] function as the STS-3/STM-1 Transmit (Add) Telecom Bus - Input Data Bus for Channel 1. The STS-3/STM-1 Telecom Bus interface will sample and latch this pin upon the falling edge of STS3TxA_CLK_1.</p> <p>If STS-3/STM-1 Telecom Bus (Channel 1) is disabled - DS3/E3/STS1_DATA_IN - DS3/E3/STS-1 Line Interface Data Input - Channel 1:</p> <p>This input accepts single-rail, recovered DS3, E3 or STS-1 data (from a DS3/E3/STS-1 LIU IC). This input pin should be connected to the RPOS output of the DS3/E3/STS-1 LIU IC (corresponding to channel 1).</p> <p>By default, the data that is applied to this input pin will be latched into the XRT94L43 upon the falling edge of the DS3/E3/STS1_CLK_IN_1 signal pin number D26.</p> <p>For DS3/E3 Applications</p> <p>The XRT94L43 can be configured to latch this input signal upon the rising edge of the DS3/E3/STS1_CLK_IN_1 signal by setting Bit 1 (DS3/E3/STS1_CLK_IN Invert), within the I/O Control Register - Channel 1 (Indirect Address = 0x2E, 0x01), (Direct Address = 0x2F01) to a "1".</p> <p>For STS-1 Applications</p> <p>The XRT94L43 can not be configured to sample the DS3/E3/STS1_DATA_IN_1 signal upon the rising edge of DS3/E3/STS1_CLK_IN_1.</p>

STS-3/STM-1 TELECOM BUS INTERFACE - TRANSMIT DIRECTION

PIN #	SIGNAL NAME	I/O	SIGNAL TYPE	DESCRIPTION
G24	STS3TxA_D_1_3 TxSBDATA_3 DS3/E3/ STS1DATA_IN_5	I	TTL	<p>Transmit STS-3/STM-1 Telecom Bus - Channel 1 - Input Data Bus Pin Number 3/DS3/E3 Framer or Receive STS-1 TOH Processor block line interface input Pin - Channel 5:</p> <p>The function of this pin depends upon whether or not the STS-3/STM-1 Telecom Bus Interface, associated with Channel 1 is enabled.</p> <p>If STS-3/STM-1 Telecom Bus (Channel 1) has been enabled - STS-3/STM-1 Transmit Telecom Bus - Input Data Bus Pin Number 3: STS3TxA_D_1_3:</p> <p>This input pin along with STS3TxA_D_1[7:4] and STS3TxA_D_1[2:0] function as the STS-3/STM-1 Transmit (Add) Telecom Bus - Input Data Bus for Channel 1. The STS-3/STM-1 Telecom Bus interface will sample and latch this pin upon the falling edge of STS3TxA_CLK_1.</p> <p>If STS-3/STM-1 Telecom Bus (Channel 1) is disabled - DS3/E3/STS1_DATA_IN - DS3/E3/STS-1 Line Interface Data Input - Channel 5:</p> <p>This input accepts single-rail, recovered DS3, E3 or STS-1 data (from a DS3/E3/STS-1 LIU IC). This input pin should be connected to the RPOS output of the DS3/E3/STS-1 LIU IC (corresponding to channel 5).</p> <p>By default, the data that is applied to this input pin will be latched into the XRT94L43 upon the falling edge of the DS3/E3/STS1_CLK_IN_5 signal pin number F23.</p> <p>For DS3/E3 Applications</p> <p>The XRT94L43 can be configured to latch this input signal upon the rising edge of the DS3/E3/STS1_CLK_IN_5 signal by setting Bit 1 (DS3/E3/STS1_CLK_IN Invert), within the I/O Control Register - Channel 5 (Indirect Address = 0x6E, 0x01), (Direct Address = 0x6F01) to a "1".</p> <p>For STS-1 Applications</p> <p>The XRT94L43 can not be configured to sample the DS3/E3/STS1_DATA_IN_5 signal upon the rising edge of DS3/E3/STS1_CLK_IN_5.</p>

STS-3/STM-1 TELECOM BUS INTERFACE - TRANSMIT DIRECTION

PIN #	SIGNAL NAME	I/O	SIGNAL TYPE	DESCRIPTION
J24	STS3TxA_D_1_4 TxSBDATA_4 DS3/E3/ STS1_DATA_IN_9	I	TTL	<p>Transmit STS-3/STM-1 Telecom Bus - Channel 1 - Input Data Bus Pin Number 4/DS3/E3 Framer or Receive STS-1 TOH Processor block line interface input Pin - Channel 9:</p> <p>The function of this pin depends upon whether or not the STS-3/STM-1 Telecom Bus Interface, associated with Channel 1 is enabled.</p> <p>If STS-3/STM-1 Telecom Bus (Channel 1) has been enabled - STS-3/STM-1 Transmit Telecom Bus - Input Data Bus Pin Number 4: STS3TxA_D_1_4:</p> <p>This input pin along with STS3TxA_D_1[7:5] and STS3TxA_D_1[3:0] function as the STS-3/STM-1 Transmit (Add) Telecom Bus - Input Data Bus for Channel 1. The STS-3/STM-1 Telecom Bus interface will sample and latch this pin upon the falling edge of STS3TxA_CLK_1.</p> <p>If STS-3/STM-1 Telecom Bus (Channel 1) is disabled - DS3/E3/STS1_DATA_IN - DS3/E3/STS-1 Line Interface Data Input - Channel 9:</p> <p>This input accepts single-rail, recovered DS3, E3 or STS-1 data (from a DS3/E3/STS-1 LIU IC). This input pin should be connected to the RPOS output of the DS3/E3/STS-1 LIU IC (corresponding to channel 9).</p> <p>By default, the data that is applied to this input pin will be latched into the XRT94L43 upon the falling edge of the DS3/E3/STS1_CLK_IN_9 signal pin number H23.</p> <p>For DS3/E3 Applications</p> <p>The XRT94L43 can be configured to latch this input signal upon the rising edge of the DS3/E3/STS1_CLK_IN_9 signal by setting Bit 1 (DS3/E3/STS1_CLK_IN Invert), within the I/O Control Register - Channel 9 (Indirect Address = 0xAE, 0x01), (Direct Address = 0xAF01) to a "1".</p> <p>For STS-1 Applications</p> <p>The XRT94L43 can not be configured to sample the DS3/E3/STS1_DATA_IN_9 signal upon the rising edge of DS3/E3/STS1_CLK_IN_9.</p>

STS-3/STM-1 TELECOM BUS INTERFACE - TRANSMIT DIRECTION

PIN #	SIGNAL NAME	I/O	SIGNAL TYPE	DESCRIPTION
D26	STS3TxA_D_1_5 DS3/E3/ STS1_CLK_IN_1 TxSBDData_5	I	TTL	<p>Transmit STS-3/STM-1 Telecom Bus - Channel 1 - Input Data Bus Pin Number 5/DS3/E3 Framer or Receive STS-1 TOH Processor block line interface clock input Pin - Channel 1:</p> <p>The function of this pin depends upon whether or not the STS-3/STM-1 Telecom Bus Interface, associated with Channel 1 is enabled.</p> <p>If STS-3/STM-1 Telecom Bus (Channel 1) has been enabled - STS-3/STM-1 Transmit Telecom Bus - Input Data Bus Pin Number 5: STS3TxA_D_1_5:</p> <p>This input pin along with STS3TxA_D_1[7:6] and STS3TxA_D_1[4:0] function as the STS-3/STM-1 Transmit (Add) Telecom Bus - Input Data Bus for Channel 1. The STS-3/STM-1 Telecom Bus interface will sample and latch this pin upon the falling edge of STS3TxA_CLK_1.</p> <p>If STS-3/STM-1 Telecom Bus (Channel 1) is disabled - DS3/E3/STS1_CLK_IN - DS3/E3/STS-1 Line Interface Clock Input - Channel 1:</p> <p>This input accepts a recovered DS3, E3 or STS-1 clock signal (from a DS3/E3/STS-1 LIU IC). This input pin should be connected to the RCLK output of the DS3/E3/STS-1 LIU IC (corresponding to channel 1). The XRT94L43 uses this clock signal to sample and latch the data that is applied to the DS3/E3/STS1_DATA_IN_1 input pin number E26.</p> <p>By default, the data that is applied to the DS3/E3/STS1_DATA_IN_1 input pin will be latched into the XRT94L43 upon the falling edge of this clock signal.</p> <p>For DS3/E3 Applications</p> <p>The XRT94L43 can be configured to latch the DS3/E3/STS1_DATA_IN_1 signal upon the rising edge of this clock signal by setting Bit 1 (DS3/E3/STS1_CLK_IN Invert), within the I/O Control Register - Channel 1 (Indirect Address = 0x2E, 0x01), (Direct Address = 0x2F01) to a "1".</p> <p>For STS-1 Applications</p> <p>The XRT94L43 can not be configured to sample the DS3/E3/STS1_DATA_IN_1 signal upon the rising edge of this clock signal.</p>

STS-3/STM-1 TELECOM BUS INTERFACE - TRANSMIT DIRECTION

PIN #	SIGNAL NAME	I/O	SIGNAL TYPE	DESCRIPTION
F23	STS3TxA_D_1_6 DS3/E3/ STS1_CLK_IN_5 TxSBData_6	I	TTL	<p>Transmit STS-3/STM-1 Telecom Bus - Channel 1 - Input Data Bus Pin Number 6/DS3/E3 Framer or Receive STS-1 TOH Processor block line interface clock input Pin - Channel 5:</p> <p>The function of this pin depends upon whether or not the STS-3/STM-1 Telecom Bus Interface, associated with Channel 1 is enabled.</p> <p>If STS-3/STM-1 Telecom Bus (Channel 1) has been enabled - STS-3/STM-1 Transmit Telecom Bus - Input Data Bus Pin Number 6: STS3TxA_D_1_6:</p> <p>This input pin along with STS3TxA_D_1_7 and STS3TxA_D_1[5:0] function as the STS-3/STM-1 Transmit (Add) Telecom Bus - Input Data Bus for Channel 1. The STS-3/STM-1 Telecom Bus interface will sample and latch this pin upon the falling edge of STS3TxA_CLK_1.</p> <p>If STS-3/STM-1 Telecom Bus (Channel 1) is disabled - DS3/E3/STS1_CLK_IN - DS3/E3/STS-1 Line Interface Clock Input - Channel 5:</p> <p>This input accepts a recovered DS3, E3 or STS-1 clock signal (from a DS3/E3/STS-1 LIU IC). This input pin should be connected to the RCLK output of the DS3/E3/STS-1 LIU IC (corresponding to channel 5). The XRT94L43 uses this clock signal to sample and latch the data that is applied to the DS3/E3/STS1_DATA_IN_5 input pin number G24.</p> <p>By default, the data that is applied to the DS3/E3/STS1_DATA_IN_5 input pin will be latched into the XRT94L43 upon the falling edge of this clock signal.</p> <p>For DS3/E3 Applications</p> <p>The XRT94L43 can be configured to latch the DS3/E3/STS1_DATA_IN_5 signal upon the rising edge of this clock signal by setting Bit 1 (DS3/E3/STS1_CLK_IN Invert), within the I/O Control Register - Channel 5 (Indirect Address = 0x6E, 0x01), (Direct Address = 0x6F01) to a "1".</p> <p>For STS-1 Applications</p> <p>The XRT94L43 can not be configured to sample the DS3/E3/STS1_DATA_IN_5 signal upon the rising edge of this clock signal.</p>

STS-3/STM-1 TELECOM BUS INTERFACE - TRANSMIT DIRECTION

PIN #	SIGNAL NAME	I/O	SIGNAL TYPE	DESCRIPTION
H23	STS3TxA_D_1_7 DS3/E3/ STS1_CLK_IN_9 TxSBData_7	I	TTL	<p>Transmit STS-3/STM-1 Telecom Bus - Channel 1 - Input Data Bus Pin Number 7/DS3/E3 Framer or Receive STS-1 TOH Processor block line interface clock input Pin - Channel 9:</p> <p>The function of this pin depends upon whether or not the STS-3/STM-1 Telecom Bus Interface, associated with Channel 1 is enabled.</p> <p>If STS-3/STM-1 Telecom Bus (Channel 1) has been enabled - STS-3/STM-1 Transmit Telecom Bus - Input Data Bus Pin Number 7: STS3TxA_D_1_7:</p> <p>This input pin along with STS3TxA_D_1[6:0] function as the STS-3/STM-1 Transmit (Add) Telecom Bus - Input Data Bus for Channel 1. The STS-3/STM-1 Telecom Bus interface will sample and latch this pin upon the falling edge of STS3TxA_CLK_1.</p> <p><i>NOTE: This input pin functions as the MSB (Most Significant Bit) of the Transmit (Add) Telecom Bus, for Channel 1.</i></p> <p>If STS-3/STM-1 Telecom Bus (Channel 1) is disabled - DS3/E3/STS1_CLK_IN - DS3/E3/STS-1 Line Interface Clock Input - Channel 9:</p> <p>This input accepts a recovered DS3, E3 or STS-1 clock signal (from a DS3/E3/STS-1 LIU IC). This input pin should be connected to the RCLK output of the DS3/E3/STS-1 LIU IC (corresponding to channel 9). The XRT94L43 uses this clock signal to sample and latch the data that is applied to the DS3/E3/STS1_DATA_IN_9 input pin number J24.</p> <p>By default, the data that is applied to the DS3/E3/STS1_DATA_IN_9 input pin will be latched into the XRT94L43 upon the falling edge of this clock signal.</p> <p>For DS3/E3 Applications</p> <p>The XRT94L43 can be configured to latch the DS3/E3/STS1_DATA_IN_9 signal upon the rising edge of this clock signal by setting Bit 1 (DS3/E3/STS1_CLK_IN Invert), within the I/O Control Register - Channel 9 (Indirect Address = 0xAE, 0x01), " (Direct Address = 0xAF01) to a "1".</p> <p>For STS-1 Applications</p> <p>The XRT94L43 can not be configured to sample the DS3/E3/STS1_DATA_IN_9 signal upon the rising edge of this clock signal.</p>

STS-3/STM-1 TELECOM BUS INTERFACE - TRANSMIT DIRECTION

PIN #	SIGNAL NAME	I/O	SIGNAL TYPE	DESCRIPTION
AD26	STS3TxA_D_2_0 RLOOP_2 TxSBData_0	I/O	TTL	<p>Transmit STS-3/STM-1 Telecom Bus - Channel 2 - Input Data Bus Pin Number 0/RLOOP_2 (General Purpose) output Pin:</p> <p>The function of this pin depends upon whether or not the STS-3/STM-1 Telecom Bus Interface, associated with Channel 2 is enabled.</p> <p>If STS-3/STM-1 Telecom Bus (Channel 2) has been enabled - STS-3/STM-1 Transmit Telecom Bus - Input Data Bus Pin Number 0:</p> <p>This input pin along with STS3TxA_D_2[7:1] function as the STS-3/STM-1 Transmit (Add) Telecom Bus - Input Data Bus for Channel 2. This input pin functions as the LSB (Least Significant Bit) input pin on the Transmit (Add) Telecom Bus - Input Data Bus. The STS-3/STM-1 Telecom Bus interface will sample and latch this pin upon the falling edge of STS3TxA_CLK_2.</p> <p>The LSB of any byte, which is being input into the STS-3/STM-1 Transmit Telecom Bus - Data Bus (for Channel 2) should be input via this pin.</p> <p>If STS-3/STM-1 Telecom Bus (Channel 2) is disabled - RLOOP_2 (General Purpose) output Pin:</p> <p>This output pin can be used as a general purpose output pin.</p> <p>The state of this output pin can be controlled by writing the appropriate value into Bit 1 (RLOOP) within the Line Interface Drive Register associated with Channel 2 (Indirect Address = 0x3E, 0x80), (Direct Address = 0x3F80).</p> <p>NOTE: For Product Legacy purposes, this pin is called RLOOP_2 because one possible application is to tie this output pin to an RLOOP (Remote Loop-back) input pin from one of Exar's XRT73L0X/XRT75L0X DS3/E3/STS-1 LIU devices. However, this output pin, and the corresponding register bit can be used for any purpose.</p>

STS-3/STM-1 TELECOM BUS INTERFACE - TRANSMIT DIRECTION

PIN #	SIGNAL NAME	I/O	SIGNAL TYPE	DESCRIPTION
AE26	STS3TxA_D_2_1 REQ_2 TxSBData_1	I/O	TTL	<p>Transmit STS-3/STM-1 Telecom Bus - Channel 2 - Input Data Bus Pin Number 1/REQ_2 (General Purpose) output Pin:</p> <p>The function of this pin depends upon whether or not the STS-3/STM-1 Telecom Bus Interface, associated with Channel 1 is enabled.</p> <p>If STS-3/STM-1 Telecom Bus (Channel 2) has been enabled - STS-3/STM-1 Transmit Telecom Bus - Input Data Bus Pin Number 1:</p> <p>This input pin along with STS3TxA_D_2[7:2] and STS3TxA_D_2_0 function as the STS-3/STM-1 Transmit (Add) Telecom Bus - Input Data Bus for Channel 2. The STS-3/STM-1 Telecom Bus interface will sample and latch this pin upon the falling edge of STS3TxA_CLK_2.</p> <p>If STS-3/STM-1 Telecom Bus (Channel 2) is disabled - REQ_2 (General Purpose) output Pin:</p> <p>This output pin can be used as a general purpose output pin. The state of this output pin can be controlled by writing the appropriate value into Bit 5 (REQB) within the Line Interface Drive Register associated with Channel 2 (Indirect Address = 0x3E, 0x80), (Direct Address = 0x3F80).</p> <p>NOTE: For Product Legacy purposes, this pin is called REQ_2 because one possible application is to tie this output pin to an REQB (Receive Equalizer By-Pass) or REQEN (Receive Equalizer Enable) input pin from one of Exar's XRT73L0X/ XRT75L0X DS3/E3/STS-1 LIU devices. However, this output pin, and the corresponding register bit can be used for any purpose.</p>

STS-3/STM-1 TELECOM BUS INTERFACE - TRANSMIT DIRECTION

PIN #	SIGNAL NAME	I/O	SIGNAL TYPE	DESCRIPTION
V24	STS3TxA_D_2_2 DS3/E3/ STS1_Data_IN_2 TxSBData_2	I	TTL	<p>Transmit STS-3/STM-1 Telecom Bus - Channel 2 - Input Data Bus Pin Number 2/DS3/E3 Framer or Receive STS-1 TOH Processor block line interface input Pin - Channel 2:</p> <p>The function of this pin depends upon whether or not the STS-3/STM-1 Telecom Bus Interface, associated with Channel 2 is enabled.</p> <p>If STS-3/STM-1 Telecom Bus (Channel 2) has been enabled - STS-3/STM-1 Transmit Telecom Bus - Input Data Bus Pin Number 2: STS3TxA_D_2_2:</p> <p>This input pin along with STS3TxA_D_2[7:3] and STS3TxA_D_2[1:0] function as the STS-3/STM-1 Transmit (Add) Telecom Bus - Input Data Bus for Channel 2. The STS-3/STM-1 Telecom Bus interface will sample and latch this pin upon the falling edge of STS3TxA_CLK_2.</p> <p>If STS-3/STM-1 Telecom Bus (Channel 2) is disabled - DS3/E3/STS1_DATA_IN - DS3/E3/STS-1 Line Interface Data Input - Channel 2:</p> <p>This input accepts single-rail, recovered DS3, E3 or STS-1 data (from a DS3/E3/STS-1 LIU IC). This input pin should be connected to the RPOS output of the DS3/E3/STS-1 LIU IC (corresponding to channel 2).</p> <p>By default, the data that is applied to this input pin will be latched into the XRT94L43 upon the falling edge of the DS3/E3/STS1_CLK_IN_2 signal pin number V25.</p> <p>For DS3/E3 Applications</p> <p>The XRT94L43 can be configured to latch this input signal upon the rising edge of the DS3/E3/STS1_CLK_IN_2 signal by setting Bit 1 (DS3/E3/STS1_CLK_IN Invert), within the I/O Control Register - Channel 2 (Indirect Address = 0x3E, 0x01), (Direct Address = 0x3F01) to a "1".</p> <p>For STS-1 Applications</p> <p>The XRT94L43 can not be configured to sample the DS3/E3/STS1_DATA_IN_2 signal upon the rising edge of DS3/E3/STS1_CLK_IN_2.</p>

STS-3/STM-1 TELECOM BUS INTERFACE - TRANSMIT DIRECTION

PIN #	SIGNAL NAME	I/O	SIGNAL TYPE	DESCRIPTION
AD24	STS3TxA_D_2_3 DS3/E3/ STS1_Data_IN_6 TxSBData_3	I	TTL	<p>Transmit STS-3/STM-1 Telecom Bus - Channel 2 - Input Data Bus Pin Number 3/DS3/E3 Framer or Receive STS-1 TOH Processor block line interface input Pin - Channel 6:</p> <p>The function of this pin depends upon whether or not the STS-3/STM-1 Telecom Bus Interface, associated with Channel 2 is enabled.</p> <p>If STS-3/STM-1 Telecom Bus (Channel 2) has been enabled - STS-3/STM-1 Transmit Telecom Bus - Input Data Bus Pin Number 3: STS3TxA_D_2_3:</p> <p>This input pin along with STS3TxA_D_2[7:4] and STS3TxA_D_2[2:0] function as the STS-3/STM-1 Transmit (Add) Telecom Bus - Input Data Bus for Channel 2. The STS-3/STM-1 Telecom Bus interface will sample and latch this pin upon the falling edge of STS3TxA_CLK_2.</p> <p>If STS-3/STM-1 Telecom Bus (Channel 2) is disabled - DS3/E3/STS1_DATA_IN - DS3/E3/STS-1 Line Interface Data Input - Channel 6:</p> <p>This input accepts single-rail, recovered DS3, E3 or STS-1 data (from a DS3/E3/STS-1 LIU IC). This input pin should be connected to the RPOS output of the DS3/E3/STS-1 LIU IC (corresponding to channel 6).</p> <p>By default, the data that is applied to this input pin will be latched into the XRT94L43 upon the falling edge of the DS3/E3/STS1_CLK_IN_6 signal pin number Y22.</p> <p>For DS3/E3 Applications</p> <p>The XRT94L43 can be configured to latch this input signal upon the rising edge of the DS3/E3/STS1_CLK_IN_6 signal by setting Bit 1 (DS3/E3/STS1_CLK_IN Invert), within the I/O Control Register - Channel 6 (Indirect Address = 0x7E, 0x01), (Direct Address = 0x7F01) to a "1".</p> <p>For STS-1 Applications</p> <p>The XRT94L43 can not be configured to sample the DS3/E3/STS1_DATA_IN_6 signal upon the rising edge of DS3/E3/STS1_CLK_IN_6.</p>

STS-3/STM-1 TELECOM BUS INTERFACE - TRANSMIT DIRECTION

PIN #	SIGNAL NAME	I/O	SIGNAL TYPE	DESCRIPTION
AF25	STS3TxA_D_2_4 DS3/E3/ STS1_Data_IN_10 TxSBData_4	I	TTL	<p>Transmit STS-3/STM-1 Telecom Bus - Channel 2 - Input Data Bus Pin Number 4/DS3/E3 Framer or Receive STS-1 TOH Processor block line interface input Pin - Channel 10:</p> <p>The function of this pin depends upon whether or not the STS-3/STM-1 Telecom Bus Interface, associated with Channel 2 is enabled.</p> <p>If STS-3/STM-1 Telecom Bus (Channel 2) has been enabled - STS-3/STM-1 Transmit Telecom Bus - Input Data Bus Pin Number 4: STS3TxA_D_2_4:</p> <p>This input pin along with STS3TxA_D_2[7:5] and STS3TxA_D_2[3:0] function as the STS-3/STM-1 Transmit (Add) Telecom Bus - Input Data Bus for Channel 2. The STS-3/STM-1 Telecom Bus interface will sample and latch this pin upon the falling edge of STS3TxA_CLK_2.</p> <p>If STS-3/STM-1 Telecom Bus (Channel 2) is disabled - DS3/E3/STS1_DATA_IN - DS3/E3/STS-1 Line Interface Data Input - Channel 10:</p> <p>This input accepts single-rail, recovered DS3, E3 or STS-1 data (from a DS3/E3/STS-1 LIU IC). This input pin should be connected to the RPOS output of the DS3/E3/STS-1 LIU IC (corresponding to channel 10).</p> <p>By default, the data that is applied to this input pin will be latched into the XRT94L43 upon the falling edge of the DS3/E3/STS1_CLK_IN_10 signal pin number AB22.</p> <p>For DS3/E3 Applications</p> <p>The XRT94L43 can be configured to latch this input signal upon the rising edge of the DS3/E3/STS1_CLK_IN_10 signal by setting Bit 1 (DS3/E3/STS1_CLK_IN Invert), within the I/O Control Register - Channel 10 (Indirect Address = 0xBE, 0x01), (Direct Address = 0xBF01) to a "1".</p> <p>For STS-1 Applications</p> <p>The XRT94L43 can not be configured to sample the DS3/E3/STS1_DATA_IN_10 signal upon the rising edge of DS3/E3/STS1_CLK_IN_10.</p>

STS-3/STM-1 TELECOM BUS INTERFACE - TRANSMIT DIRECTION

PIN #	SIGNAL NAME	I/O	SIGNAL TYPE	DESCRIPTION
V25	STS3TxA_D_2_5 DS3/E3/ STS1_CLK_IN_2 TxSBDData_5	I	TTL	<p>Transmit STS-3/STM-1 Telecom Bus - Channel 2 - Input Data Bus Pin Number 5/DS3/E3 Framer or Receive STS-1 TOH Processor block line interface clock input Pin - Channel 2:</p> <p>The function of this pin depends upon whether or not the STS-3/STM-1 Telecom Bus Interface, associated with Channel 2 is enabled.</p> <p>If STS-3/STM-1 Telecom Bus (Channel 2) has been enabled - STS-3/STM-1 Transmit Telecom Bus - Input Data Bus Pin Number 5: STS3TxA_D_2_5:</p> <p>This input pin along with STS3TxA_D_2[7:6] and STS3TxA_D_2[4:0] function as the STS-3/STM-1 Transmit (Add) Telecom Bus - Input Data Bus for Channel 2. The STS-3/STM-1 Telecom Bus interface will sample and latch this pin upon the falling edge of STS3TxA_CLK_2.</p> <p>If STS-3/STM-1 Telecom Bus (Channel 2) is disabled - DS3/E3/STS1_CLK_IN - DS3/E3/STS-1 Line Interface Clock Input - Channel 2:</p> <p>This input accepts a recovered DS3, E3 or STS-1 clock signal (from a DS3/E3/STS-1 LIU IC). This input pin should be connected to the RCLK output of the DS3/E3/STS-1 LIU IC (corresponding to channel 2). The XRT94L43 uses this clock signal to sample and latch the data that is applied to the DS3/E3/STS1_DATA_IN_2 input pin number V24.</p> <p>By default, the data that is applied to the DS3/E3/STS1_DATA_IN_2 input pin will be latched into the XRT94L43 upon the falling edge of this clock signal.</p> <p>For DS3/E3 Applications</p> <p>The XRT94L43 can be configured to latch the DS3/E3/STS1_DATA_IN_2 signal upon the rising edge of this clock signal by setting Bit 1 (DS3/E3/STS1_CLK_IN Invert), within the I/O Control Register - Channel 2 (Indirect Address = 0x3E, 0x01), (Direct Address = 0x3F01) to a "1".</p> <p>For STS-1 Applications</p> <p>The XRT94L43 can not be configured to sample the DS3/E3/STS1_DATA_IN_2 signal upon the rising edge of this clock signal.</p>

STS-3/STM-1 TELECOM BUS INTERFACE - TRANSMIT DIRECTION

PIN #	SIGNAL NAME	I/O	SIGNAL TYPE	DESCRIPTION
Y22	STS3TxA_D_2_6 DS3/E3/ STS1_CLK_IN_6 TxSBData_6	I	TTL	<p>Transmit STS-3/STM-1 Telecom Bus - Channel 2 - Input Data Bus Pin Number 6/DS3/E3 Framer or Receive STS-1 TOH Processor block line interface clock input Pin - Channel 6:</p> <p>The function of this pin depends upon whether or not the STS-3/STM-1 Telecom Bus Interface, associated with Channel 2 is enabled.</p> <p>If STS-3/STM-1 Telecom Bus (Channel 2) has been enabled - STS-3/STM-1 Transmit Telecom Bus - Input Data Bus Pin Number 6: STS3TxA_D_2_6:</p> <p>This input pin along with STS3TxA_D_2_7 and STS3TxA_D_2[5:0] function as the STS-3/STM-1 Transmit (Add) Telecom Bus - Input Data Bus for Channel 2. The STS-3/STM-1 Telecom Bus interface will sample and latch this pin upon the falling edge of STS3TxA_CLK_2.</p> <p>If STS-3/STM-1 Telecom Bus (Channel 2) is disabled - DS3/E3/STS1_CLK_IN - DS3/E3/STS-1 Line Interface Clock Input - Channel 6:</p> <p>This input accepts a recovered DS3, E3 or STS-1 clock signal (from a DS3/E3/STS-1 LIU IC). This input pin should be connected to the RCLK output of the DS3/E3/STS-1 LIU IC (corresponding to channel 6). The XRT94L43 uses this clock signal to sample and latch the data that is applied to the DS3/E3/STS1_DATA_IN_6 input pin number AD24.</p> <p>By default, the data that is applied to the DS3/E3/STS1_DATA_IN_6 input pin will be latched into the XRT94L43 upon the falling edge of this clock signal.</p> <p>For DS3/E3 Applications</p> <p>The XRT94L43 can be configured to latch the DS3/E3/STS1_DATA_IN_6 signal upon the rising edge of this clock signal by setting Bit 1 (DS3/E3/STS1_CLK_IN Invert), within the I/O Control Register - Channel 6 (Indirect Address = 0x7E, 0x01), (Direct Address = 0x7F01) to a "1".</p> <p>For STS-1 Applications</p> <p>The XRT94L43 can not be configured to sample the DS3/E3/STS1_DATA_IN_6 signal upon the rising edge of this clock signal.</p>

STS-3/STM-1 TELECOM BUS INTERFACE - TRANSMIT DIRECTION

PIN #	SIGNAL NAME	I/O	SIGNAL TYPE	DESCRIPTION
AB22	STS3TxA_D_2_7 DS3/E3/ STS1_Clk_IN_10 TxSBDData_7	I	TTL	<p>Transmit STS-3/STM-1 Telecom Bus - Channel 2 - Input Data Bus Pin Number 7/DS3/E3 Framer or Receive STS-1 TOH Processor block line interface clock input Pin - Channel 10:</p> <p>The function of this pin depends upon whether or not the STS-3/STM-1 Telecom Bus Interface, associated with Channel 2 is enabled.</p> <p>If STS-3/STM-1 Telecom Bus (Channel 2) has been enabled - STS-3/STM-1 Transmit Telecom Bus - Input Data Bus Pin Number 7: STS3TxA_D_2_7:</p> <p>This input pin along with STS3TxA_D_2[6:0] function as the STS-3/STM-1 Transmit (Add) Telecom Bus - Input Data Bus for Channel 2. The STS-3/STM-1 Telecom Bus interface will sample and latch this pin upon the falling edge of STS3TxA_CLK_2.</p> <p><i>NOTE: This input pin functions as the MSB (Most Significant Bit) of the Transmit (Add) Telecom Bus, for Channel 2.</i></p> <p>If STS-3/STM-1 Telecom Bus (Channel 2) is disabled - DS3/E3/STS1_CLK_IN - DS3/E3/STS-1 Line Interface Clock Input - Channel 10:</p> <p>This input accepts a recovered DS3, E3 or STS-1 clock signal (from a DS3/E3/STS-1 LIU IC). This input pin should be connected to the RCLK output of the DS3/E3/STS-1 LIU IC (corresponding to channel 10). The XRT94L43 uses this clock signal to sample and latch the data that is applied to the DS3/E3/STS1_DATA_IN_10 input pin number AF25.</p> <p>By default, the data that is applied to the DS3/E3/STS1_DATA_IN_10 input pin will be latched into the XRT94L43 upon the falling edge of this clock signal.</p> <p>For DS3/E3 Applications</p> <p>The XRT94L43 can be configured to latch the DS3/E3/STS1_DATA_IN_10 signal upon the rising edge of this clock signal by setting Bit 1 (DS3/E3/STS1_CLK_IN Invert), within the I/O Control Register - Channel 10 (Indirect Address = 0xBE, 0x01), (Direct Address = 0xBF01) to a "1".</p> <p>For STS-1 Applications</p> <p>The XRT94L43 can not be configured to sample the DS3/E3/STS1_DATA_IN_10 signal upon the rising edge of this clock signal.</p>

STS-3/STM-1 TELECOM BUS INTERFACE - TRANSMIT DIRECTION

PIN #	SIGNAL NAME	I/O	SIGNAL TYPE	DESCRIPTION
AC18	STS3TxA_D_3_0 RLOOP_3 TxSBData_0	I/O	TTL/ CMOS	<p>Transmit STS-3/STM-1 Telecom Bus - Channel 3 - Input Data Bus Pin Number 0/RLOOP_3 General Purpose) output Pin:</p> <p>The function of this pin depends upon whether or not the STS-3/STM-1 Telecom Bus Interface, associated with Channel 2 is enabled.</p> <p>If STS-3/STM-1 Telecom Bus (Channel 3) has been enabled - STS-3/STM-1 Transmit Telecom Bus - Input Data Bus Pin Number 0:</p> <p>This input pin along with STS3TxA_D_3[7:1] function as the STS-3/STM-1 Transmit (Add) Telecom Bus - Input Data Bus for Channel 3. This input pin functions as the LSB (Least Significant Bit) input pin on the Transmit (Add) Telecom Bus - Input Data Bus. The STS-3/STM-1 Telecom Bus interface will sample and latch this pin upon the falling edge of STS3TxA_CLK_3. The LSB of any byte, which is being input into the STS-3/STM-1 Transmit Telecom Bus - Data Bus (for Channel 3) should be input via this pin.</p> <p>If STS-3/STM-1 Telecom Bus (Channel 3) is disabled - RLOOP_3 (General Purpose) output Pin.</p> <p>This output pin can be used as a general purpose output pin. The state of this output pin can be controlled by writing the appropriate value into Bit 1 (RLOOP) within the Line Interface Drive Register associated with Channel 3 (Indirect Address = 0x4E, 0x80), (Direct Address = 0x4F80).</p> <p>NOTE: For Product Legacy purposes, this pin is called RLOOP_3 because one possible application is to tie this output pin to an RLOOP (Remote Loop-back) input pin from one of Exar's XRT73L0X/XRT75L0X DS3/E3/STS-1 LIU devices. However, this output pin, and the corresponding register bit can be used for any purpose.</p>

STS-3/STM-1 TELECOM BUS INTERFACE - TRANSMIT DIRECTION

PIN #	SIGNAL NAME	I/O	SIGNAL TYPE	DESCRIPTION
AB18	STS3TxA_D_3_1 REQ_3 TxSBData_1	I/O	TTL/ CMOS	<p>Transmit STS-3/STM-1 Telecom Bus - Channel 3 - Input Data Bus Pin Number 1/REQ_3 (General Purpose) output Pin:</p> <p>The function of this pin depends upon whether or not the STS-3/STM-1 Telecom Bus Interface, associated with Channel 3 is enabled.</p> <p>If STS-3/STM-1 Telecom Bus (Channel 3) has been enabled - STS-3/STM-1 Transmit Telecom Bus - Input Data Bus Pin Number 1:</p> <p>This input pin along with STS3TxA_D_3[7:2] and STS3TxA_D_3_0 function as the STS-3/STM-1 Transmit (Add) Telecom Bus - Input Data Bus for Channel 3. The STS-3/STM-1 Telecom Bus interface will sample and latch this pin upon the falling edge of STS3TxA_CLK_3.</p> <p>If STS-3/STM-1 Telecom Bus (Channel 3) is disabled - REQ_3 (General Purpose) output Pin.</p> <p>This output pin can be used as a general purpose output pin. The state of this output pin can be controlled by writing the appropriate value into Bit 5 (REQB) within the Line Interface Drive Register associated with Channel 3 (Indirect Address = 0x4E, 0x80), (Direct Address = 0x4F80).</p> <p>NOTE: For Product Legacy purposes, this pin is called REQ_3 because one possible application is to tie this output pin to an REQB (Receive Equalizer By-Pass) or REQEN (Receive Equalizer Enable) input pin from one of Exar's XRT73L0X/ XRT75L0X DS3/E3/STS-1 LIU devices. However, this output pin, and the corresponding register bit can be used for any purpose.</p>

STS-3/STM-1 TELECOM BUS INTERFACE - TRANSMIT DIRECTION

PIN #	SIGNAL NAME	I/O	SIGNAL TYPE	DESCRIPTION
AA20	STS3TxA_D_3_2 DS3/E3/ STS1_Data_IN_3 TxSBData_2	I	TTL	<p>Transmit STS-3/STM-1 Telecom Bus - Channel 3 - Input Data Bus Pin Number 2/DS3/E3 Framer or Receive STS-1 TOH Processor block line interface input Pin - Channel 3:</p> <p>The function of this pin depends upon whether or not the STS-3/STM-1 Telecom Bus Interface, associated with Channel 3 is enabled.</p> <p>If STS-3/STM-1 Telecom Bus (Channel 3) has been enabled - STS-3/STM-1 Transmit Telecom Bus - Input Data Bus Pin Number 2: STS3TxA_D_3_2:</p> <p>This input pin along with STS3TxA_D_3[7:3] and STS3TxA_D_3[1:0] function as the STS-3/STM-1 Transmit (Add) Telecom Bus - Input Data Bus for Channel 3. The STS-3/STM-1 Telecom Bus interface will sample and latch this pin upon the falling edge of STS3TxA_CLK_3.</p> <p>If STS-3/STM-1 Telecom Bus (Channel 3) is disabled - DS3/E3/STS1_DATA_IN - DS3/E3/STS-1 Line Interface Data Input - Channel 3:</p> <p>This input accepts single-rail, recovered DS3, E3 or STS-1 data (from a DS3/E3/STS-1 LIU IC). This input pin should be connected to the RPOS output of the DS3/E3/STS-1 LIU IC (corresponding to channel 3).</p> <p>By default, the data that is applied to this input pin will be latched into the XRT94L43 upon the falling edge of the DS3/E3/STS1_CLK_IN_3 signal pin number AD22.</p> <p>For DS3/E3 Applications</p> <p>The XRT94L43 can be configured to latch this input signal upon the rising edge of the DS3/E3/STS1_CLK_IN_3 signal by setting Bit 1 (DS3/E3/STS1_CLK_IN Invert), within the I/O Control Register - Channel 3 (Indirect Address = 0x4E, 0x01), (Direct Address = 0x4F01) to a "1".</p> <p>For STS-1 Applications</p> <p>The XRT94L43 can not be configured to sample the DS3/E3/STS1_DATA_IN_3 signal upon the rising edge of DS3/E3/STS1_CLK_IN_3.</p>

STS-3/STM-1 TELECOM BUS INTERFACE - TRANSMIT DIRECTION

PIN #	SIGNAL NAME	I/O	SIGNAL TYPE	DESCRIPTION
AB19	STS3TxA_D_3_3 DS3/E3/ STS1_Data_IN_7 TxSBDData_3	I	TTL	<p>Transmit STS-3/STM-1 Telecom Bus - Channel 3 - Input Data Bus Pin Number 3/DS3/E3 Framer or Receive STS-1 TOH Processor block line interface input Pin - Channel 7:</p> <p>The function of this pin depends upon whether or not the STS-3/STM-1 Telecom Bus Interface, associated with Channel 3 is enabled.</p> <p>If STS-3/STM-1 Telecom Bus (Channel 3) has been enabled - STS-3/STM-1 Transmit Telecom Bus - Input Data Bus Pin Number 3: STS3TxA_D_3_3:</p> <p>This input pin along with STS3TxA_D_3[7:4] and STS3TxA_D_3[2:0] function as the STS-3/STM-1 Transmit (Add) Telecom Bus - Input Data Bus for Channel 3. The STS-3/STM-1 Telecom Bus interface will sample and latch this pin upon the falling edge of STS3TxA_CLK_3.</p> <p>If STS-3/STM-1 Telecom Bus (Channel 3) is disabled - DS3/E3/STS1_DATA_IN - DS3/E3/STS-1 Line Interface Data Input - Channel 7:</p> <p>This input accepts single-rail, recovered DS3, E3 or STS-1 data (from a DS3/E3/STS-1 LIU IC). This input pin should be connected to the RPOS output of the DS3/E3/STS-1 LIU IC (corresponding to channel 7).</p> <p>By default, the data that is applied to this input pin will be latched into the XRT94L43 upon the falling edge of the DS3/E3/STS1_CLK_IN_7 signal pin number AA19.</p> <p>For DS3/E3 Applications</p> <p>The XRT94L43 can be configured to latch this input signal upon the rising edge of the DS3/E3/STS1_CLK_IN_7 signal by setting Bit 1 (DS3/E3/STS1_CLK_IN Invert), within the I/O Control Register - Channel 7 (Indirect Address = 0x8E, 0x01), (Direct Address = 0x8F01) to a "1".</p> <p>For STS-1 Applications</p> <p>The XRT94L43 can not be configured to sample the DS3/E3/STS1_DATA_IN_7 signal upon the rising edge of DS3/E3/STS1_CLK_IN_7.</p>

STS-3/STM-1 TELECOM BUS INTERFACE - TRANSMIT DIRECTION

PIN #	SIGNAL NAME	I/O	SIGNAL TYPE	DESCRIPTION
AD16	STS3TxA_D_3_4 DS3/E3/ STS1_Data_IN_11 TxSBData_4	I	TTL	<p>Transmit STS-3/STM-1 Telecom Bus - Channel 3 - Input Data Bus Pin Number 4/DS3/E3 Framer or Receive STS-1 TOH Processor block line interface input Pin - Channel 11 (DS3/E3/STS1_DATA_IN_11):</p> <p>The function of this pin depends upon whether or not the STS-3/STM-1 Telecom Bus Interface, associated with Channel 3 is enabled.</p> <p>If STS-3/STM-1 Telecom Bus (Channel 3) has been enabled - STS-3/STM-1 Transmit Telecom Bus - Input Data Bus Pin Number 4: STS3TxA_D_3_4:</p> <p>This input pin along with STS3TxA_D_3[7:5] and STS3TxA_D_3[3:0] function as the STS-3/STM-1 Transmit (Add) Telecom Bus - Input Data Bus for Channel 3. The STS-3/STM-1 Telecom Bus interface will sample and latch this pin upon the falling edge of STS3TxA_CLK_3.</p> <p>If STS-3/STM-1 Telecom Bus (Channel 3) is disabled - DS3/E3/STS1_DATA_IN - DS3/E3/STS-1 Line Interface Data Input - Channel 11:</p> <p>This input accepts single-rail, recovered DS3, E3 or STS-1 data (from a DS3/E3/STS-1 LIU IC). This input pin should be connected to the RPOS output of the DS3/E3/STS-1 LIU IC (corresponding to channel 11).</p> <p>By default, the data that is applied to this input pin will be latched into the XRT94L43 upon the falling edge of the DS3/E3/STS1_CLK_IN_11 signal pin number AB16.</p> <p>For DS3/E3 Applications</p> <p>The XRT94L43 can be configured to latch this input signal upon the rising edge of the DS3/E3/STS1_CLK_IN_11 signal by setting Bit 1 (DS3/E3/STS1_CLK_IN Invert), within the I/O Control Register - Channel 11 (Indirect Address = 0xCE, 0x01), (Direct Address = 0xCF01) to a "1".</p> <p>For STS-1 Applications</p> <p>The XRT94L43 can not be configured to sample the DS3/E3/STS1_DATA_IN_11 signal upon the rising edge of DS3/E3/STS1_CLK_IN_11.</p>

STS-3/STM-1 TELECOM BUS INTERFACE - TRANSMIT DIRECTION

PIN #	SIGNAL NAME	I/O	SIGNAL TYPE	DESCRIPTION
AD22	STS3TxA_D_3_5 DS3/E3/ STS1_CLK_IN_3 TxSBData_5	I	TTL	<p>Transmit STS-3/STM-1 Telecom Bus - Channel 3 - Input Data Bus Pin Number 5/DS3/E3 Framer or Receive STS-1 TOH Processor block line interface clock input Pin - Channel 3:</p> <p>The function of this pin depends upon whether or not the STS-3/STM-1 Telecom Bus Interface, associated with Channel 3 is enabled.</p> <p>If STS-3/STM-1 Telecom Bus (Channel 3) has been enabled - STS-3/STM-1 Transmit Telecom Bus - Input Data Bus Pin Number 5: STS3TxA_D_3_5:</p> <p>This input pin along with STS3TxA_D_3[7:6] and STS3TxA_D_3[4:0] function as the STS-3/STM-1 Transmit (Add) Telecom Bus - Input Data Bus for Channel 3. The STS-3/STM-1 Telecom Bus interface will sample and latch this pin upon the falling edge of STS3TxA_CLK_3.</p> <p>If STS-3/STM-1 Telecom Bus (Channel 3) is disabled - DS3/E3/STS1_CLK_IN - DS3/E3/STS-1 Line Interface Clock Input - Channel 3:</p> <p>This input accepts a recovered DS3, E3 or STS-1 clock signal (from a DS3/E3/STS-1 LIU IC). This input pin should be connected to the RCLK output of the DS3/E3/STS-1 LIU IC (corresponding to channel 3). The XRT94L43 uses this clock signal to sample and latch the data that is applied to the DS3/E3/STS1_DATA_IN_3 input pin number AA20.</p> <p>By default, the data that is applied to the DS3/E3/STS1_DATA_IN_3 input pin will be latched into the XRT94L43 upon the falling edge of this clock signal.</p> <p>For DS3/E3 Applications</p> <p>The XRT94L43 can be configured to latch the DS3/E3/STS1_DATA_IN_3 signal upon the rising edge of this clock signal by setting Bit 1 (DS3/E3/STS1_CLK_IN Invert), within the I/O Control Register - Channel 3 (Indirect Address = 0x4E, 0x01), (Direct Address = 0x4F01) to a "1".</p> <p>For STS-1 Applications</p> <p>The XRT94L43 can not be configured to sample the DS3/E3/STS1_DATA_IN_3 signal upon the rising edge of this clock signal.</p>

STS-3/STM-1 TELECOM BUS INTERFACE - TRANSMIT DIRECTION

PIN #	SIGNAL NAME	I/O	SIGNAL TYPE	DESCRIPTION
AA19	STS3TxA_D_3_6 DS3/E3/ STS1_Clk_IN_7 TxSBData_6	I	TTL	<p>Transmit STS-3/STM-1 Telecom Bus - Channel 3 - Input Data Bus Pin Number 6/DS3/E3 Framer or Receive STS-1 TOH Processor block line interface clock input Pin - Channel 7:</p> <p>The function of this pin depends upon whether or not the STS-3/STM-1 Telecom Bus Interface, associated with Channel 3 is enabled.</p> <p>If STS-3/STM-1 Telecom Bus (Channel 3) has been enabled - STS-3/STM-1 Transmit Telecom Bus - Input Data Bus Pin Number 6: STS3TxA_D_3_6:</p> <p>This input pin along with STS3TxA_D_3_7 and STS3TxA_D_3[5:0] function as the STS-3/STM-1 Transmit (Add) Telecom Bus - Input Data Bus for Channel 3. The STS-3/STM-1 Telecom Bus interface will sample and latch this pin upon the falling edge of STS3TxA_CLK_3.</p> <p>If STS-3/STM-1 Telecom Bus (Channel 3) is disabled - DS3/E3/STS1_CLK_IN - DS3/E3/STS-1 Line Interface Clock Input - Channel 7:</p> <p>This input accepts a recovered DS3, E3 or STS-1 clock signal (from a DS3/E3/STS-1 LIU IC). This input pin should be connected to the RCLK output of the DS3/E3/STS-1 LIU IC (corresponding to channel 7). The XRT94L43 uses this clock signal to sample and latch the data that is applied to the DS3/E3/STS1_DATA_IN_7 input pin number AB19.</p> <p>By default, the data that is applied to the DS3/E3/STS1_DATA_IN_7 input pin will be latched into the XRT94L43 upon the falling edge of this clock signal.</p> <p>For DS3/E3 Applications</p> <p>The XRT94L43 can be configured to latch the DS3/E3/STS1_DATA_IN_7 signal upon the rising edge of this clock signal by setting Bit 1 (DS3/E3/STS1_CLK_IN Invert), within the I/O Control Register - Channel 7 (Indirect Address = 0x8E, 0x01), (Direct Address = 0x8F01) to a "1".</p> <p>For STS-1 Applications</p> <p>The XRT94L43 can not be configured to sample the DS3/E3/STS1_DATA_IN_7 signal upon the rising edge of this clock signal.</p>

STS-3/STM-1 TELECOM BUS INTERFACE - TRANSMIT DIRECTION

PIN #	SIGNAL NAME	I/O	SIGNAL TYPE	DESCRIPTION
AB16	STS3TxA_D_3_7 DS3/E3/ STS1_CLK_IN_11 TxSBData_7	I	TTL	<p>Transmit STS-3/STM-1 Telecom Bus - Channel 3 - Input Data Bus Pin Number 7/DS3/E3 Framer or Receive STS-1 TOH Processor block line interface clock input Pin - Channel 11:</p> <p>The function of this pin depends upon whether or not the STS-3/STM-1 Telecom Bus Interface, associated with Channel 3 is enabled.</p> <p>If STS-3/STM-1 Telecom Bus (Channel 3) has been enabled - STS-3/STM-1 Transmit Telecom Bus - Input Data Bus Pin Number 7: STS3TxA_D_3_7:</p> <p>This input pin along with STS3TxA_D_3[6:0] function as the STS-3/STM-1 Transmit (Add) Telecom Bus - Input Data Bus for Channel 3. The STS-3/STM-1 Telecom Bus interface will sample and latch this pin upon the falling edge of STS3TxA_CLK_3.</p> <p><i>NOTE: This input pin functions as the MSB (Most Significant Bit) of the Transmit (Add) Telecom Bus, for Channel 3.</i></p> <p>If STS-3/STM-1 Telecom Bus (Channel 3) is disabled - DS3/E3/STS1_CLK_IN - DS3/E3/STS-1 Line Interface Clock Input - Channel 11:</p> <p>This input accepts a recovered DS3, E3 or STS-1 clock signal (from a DS3/E3/STS-1 LIU IC). This input pin should be connected to the RCLK output of the DS3/E3/STS-1 LIU IC (corresponding to channel 11). The XRT94L43 uses this clock signal to sample and latch the data that is applied to the DS3/E3/STS1_DATA_IN_11 input pin number AD16.</p> <p>By default, the data that is applied to the DS3/E3/STS1_DATA_IN_11 input pin will be latched into the XRT94L43 upon the falling edge of this clock signal.</p> <p>For DS3/E3 Applications</p> <p>The XRT94L43 can be configured to latch the DS3/E3/STS1_DATA_IN_11 signal upon the rising edge of this clock signal by setting Bit 1 (DS3/E3/STS1_CLK_IN Invert), within the I/O Control Register - Channel 11 (Indirect Address = 0xCE, 0x01), (Direct Address = 0xCF01) to a "1".</p> <p>For STS-1 Applications</p> <p>The XRT94L43 can not be configured to sample the DS3/E3/STS1_DATA_IN_11 signal upon the rising edge of this clock signal.</p>

STS-3/STM-1 TELECOM BUS INTERFACE - TRANSMIT DIRECTION

PIN #	SIGNAL NAME	I/O	SIGNAL TYPE	DESCRIPTION
AB25	TxREFCLK SSE_POS	O	CMOS	<p>Transmit STS-3/STM-1 Telecom Bus Reference Clock Output Pin/Slow-Speed Interface - Egress - Positive Data I/O:</p> <p>The exact function of this pin depends upon whether or not the STS-3/STM-1 Telecom Bus is enabled, and whether the Slow-Speed Interface is enabled.</p> <p>Transmit STS-3/STM-1 Telecom Bus Reference Clock Output Pin:</p> <p>This pin generates a 19.44MHz clock signal that is ultimately derived from the Clock Synthesizer block (within the XRT94L43 device).</p> <p>If the user configures the STS-3/STM-1 Telecom Bus Interface to operate in the "Re-Phase OFF" mode, then the device (or entity) that is transmitting STS-3/STM-1 data (to the Transmit STS-3/STM-1 Telecom Bus Interface) must synchronizes its data transmission to this output signal.</p> <p>The user is not required to use this signal if the STS-3/STM-1 Telecom Bus Interface has been configured to operate in the "Re-Phase ON" Mode.</p> <p>SSE_POS (Slow-Speed Interface - Egress - Port is enabled):</p> <p>If the Slow-Speed Interface - Egress (SSE) Port is enabled, then this pin will function as either the SSE_POS output pin or the SSE_POS input pin. If the user configures the SSE port to operate in the "Insert" Mode, then the SSE port will be configured to replace any "user-selected" Egress DS3/E3 or STS-1 data-stream (within the XRT94L43 device) with the data that is applied to the SSE_POS and SSE_NEG input pins. More specifically, in the "Insert" Mode, this pin will function as the "SSE_POS" input pin. In this case, the SSE port will sample and latch the contents of the input pin (along with the SSE_NEG, in a Dual-Rail manner) upon the falling edge of the SSE_CLK input clock signal.</p> <p>If the user configures the SSE port to operate in the "Extract" Mode, then the SSE port will output any "user-selected" Egress DS3/E3 or STS-1 signal (within the XRT94L43 device) via this output port. More specifically, in the "Extract Mode" this pin will function as the "SSE_POS" output pin. In this case, the SSE port will output data via this pin, along with the SSE_POS output pin (in a Dual-Rail Manner) upon the rising edge of the SSE_CLK output signal.</p>

STS-3/STM-1 TELECOM BUS INTERFACE - TRANSMIT DIRECTION

PIN #	SIGNAL NAME	I/O	SIGNAL TYPE	DESCRIPTION
AA24	TxSBFP_OUT SSI_NEG	O	CMOS	<p>Transmit STS-3/STM-1 Telecom Bus Framing Pulse Output Pin: This pin generates a pulse at an 8kHz rate. This signal is ultimately derived from the Clock Synthesizer block (within the XRT94L43). If the STS-3/STM-1 Telecom Bus Interface is configured to operate in the "Re-Phase OFF" Mode, then the devices (or entities) that are transmitting STS-3/STM-1 data (to the Transmit STS-3/STM-1 Telecom Bus Interface) must synchronize their STS-3/STM-1 frame transmission to this output signal. In the Re-Phase OFF Mode, each device or entity must align their STS-3/STM-1 Frame transmission to this signal, in order to insure that all four Transmit STS-3/STM-1 Telecom Bus Interfaces are presented with TOH data simultaneously.</p> <p>Transmit STS-3/STM-1 Telecom Bus Framing Pulse Output Pin/ Slow-Speed Interface - Ingress - Negative Data I/O: The exact function of this pin depends upon whether or not the STS-3/STM-1 Telecom Bus is enabled and whether the Slow-Speed Interface is enabled.</p> <p>Transmit STS-3/STM-1 Telecom Bus Framing Pulse Output Pin: This pin generates a pulse at an 8kHz rate. This signal is ultimately derived from the Clock Synthesizer block (within the XRT94L43). If the user configures the STS-3/STM-1 Telecom Bus Interface to operate in the "Re-Phase OFF" Mode, then the devices (or entities) that is transmitting STS-3/STM-1 data (to the Transmit STS-3/STM-1 Telecom Bus Interface) must synchronize its STS-3/STM-1 frame transmission to this output signal. In the Re-Phase OFF Mode, each device or entity must align their STS-3/STM-1 Frame transmission to this signal, in order to insure that all four Transmit STS-3/STM-1 Telecom Bus Interfaces are presented with TOH data simultaneously.</p> <p>SSI_NEG (Slow-Speed Interface - Ingress Port is enabled): If the Slow-Speed Interface - Ingress (SSI) Port is enabled, then this pin will function as either the SSI_NEG output pin or the SSI_NEG input pin. If the user configures the SSI port to operate in the "Insert" Mode, then the SSI port will be configured to replace any "user-selected" Ingress DS3/E3 or STS-1 data-stream (within the XRT94L43 device) with the data that is applied to the SSI_POS and SSI_NEG input pins. More specifically, in the "Insert" Mode, this pin will function as the SSI_NEG input pin. In this case, the SSI port will sample and latch the contents of this input pin (along with the SSI_POS input pin, in a Dual-Rail Manner) upon the falling edge of the SSI_CLK input clock signal. If the user configures the SSI port to operate in the "Extract" Mode, then the SSI port will output any "user-selected" Ingress DS3/E3 or STS-1 signal (within the XRT94L43 device) via this output port. More specifically, in the "Extract Mode" this pin will function as the "SSI_NEG" output pin. In this case, the SSI port will output data via this pin, along with the SSI_POS output pin (in a Dual-Rail Manner) upon the rising edge of the SSI_CLK output signal.</p>

RXSTS-1 TOH/POH INTERFACE

PIN #	SIGNAL NAME	I/O	SIGNAL TYPE	DESCRIPTION
A14 F20 K25 AD18 E16 H22 AA25 AC15 E19 K22 AD23 AA12	RxSTS1OHSel_0 RxSTS1OHSel_1 RxSTS1OHSel_2 RxSTS1OHSel_3 RxSTS1OHSel_4 RxSTS1OHSel_5 RxSTS1OHSel_6 RxSTS1OHSel_7 RxSTS1OHSel_8 RxSTS1OHSel_9 RxSTS1OHSel_10 RxSTS1OHSel_11	O	CMOS	<p>Receive STS-1 TOH and POH Output Port - POH Data Indicator:</p> <p>These output pins, along with RxSTS1OHClk_n, RxSTS1OHFrame_n and RxSTS1OH_n function as the Receive STS-1 TOH and POH Output Port.</p> <p>These output pins indicate whether POH or TOH data is being output via the RxSTS1OH_n output pins.</p> <p>These output pins will toggle "High" coincident with the POH data as it is being output via the RxSTS1OH_n output pins. Conversely, these output pins will toggle "Low" coincident with the TOH data as it is being output via the RxSTS1OH_n output pins.</p> <p>NOTE: <i>These output pins are updated upon the falling edge of RxSTS1OHClk_n. As a consequence, external circuitry, receiving this data, should sample this data upon the rising edge of RxSTS1OHClk_n.</i></p>
D11 G22 U23 AD20 B15 J21 AA26 AF15 E17 K23 AF26 AD11	RxSTS1OH_0 RxSTS1OH_1 RxSTS1OH_2 RxSTS1OH_3 RxSTS1OH_4 RxSTS1OH_5 RxSTS1OH_6 RxSTS1OH_7 RxSTS1OH_8 RxSTS1OH_9 RxSTS1OH_10 RxSTS1OH_11	O	CMOS	<p>Receive STS-1 TOH and POH Output Port - Output pin:</p> <p>These output pins, along with RxSTS1OHSel_n, RxSTS1OHClk_n and RxSTS1OHFrame_n function as the Receive STS-1 TOH and POH Output Port.</p> <p>Each bit, within the TOH and POH bytes (within the incoming STS-1 data stream) is updated upon the falling edge of RxSTS1OHClk_n. As a consequence, external circuitry receiving this data, should sample this data upon the rising edge of RxSTS1OHClk_n.</p> <p>NOTES:</p> <ol style="list-style-type: none"> <i>The external circuitry can determine whether or not it is receiving POH or TOH data via this output pin. The RxSTS1OHSel_n output pin will be "High" anytime POH data is being output via these output pins. Conversely, the RxSTS1OHSel_n output pin will be "Low" anytime TOH data is being output via these output pins.</i> <i>TOH and POH data, associated with Receive STS-1 TOH and POH Processor Block - Channel 0 will be output via the RxSTS1OH_0, and so on.</i>

RXSTS-1 TOH/POH INTERFACE

PIN #	SIGNAL NAME	I/O	SIGNAL TYPE	DESCRIPTION
F12 F22 T24 AE20 A18 H21 AB24 AE16 E18 K26 AA23 AF10	RxSTS1OHClk_0 RxSTS1OHClk_1 RxSTS1OHClk_2 RxSTS1OHClk_3 RxSTS1OHClk_4 RxSTS1OHClk_5 RxSTS1OHClk_6 RxSTS1OHClk_7 RxSTS1OHClk_8 RxSTS1OHClk_9 RxSTS1OHClk_10 RxSTS1OHClk_11	O	CMOS	<p>Receive STS-1 TOH and POH Output Port - Clock Output signal:</p> <p>These output pins, along with RxSTS1OH_n, RxSTS1OHFrame_n, and RxSTS1OHSel_n function as the Receive STS-1 TOH and POH Output Port.</p> <p>These output pins function as the Clock Output signals for the Receive STS-1 TOH and POH Output Port. The RxSTS1OH_n, RxSTS1Frame_n and RxSTS1OHSel_n output pins are updated upon the falling edge of this clock signal.</p>
D12 E22 U26 AF18 B17 J22 W22 AF12 F19 K24 AF23 AD10	RxSTS1OHFrame_0 RxSTS1OHFrame_1 RxSTS1OHFrame_2 RxSTS1OHFrame_3 RxSTS1OHFrame_4 RxSTS1OHFrame_5 RxSTS1OHFrame_6 RxSTS1OHFrame_7 RxSTS1OHFrame_8 RxSTS1OHFrame_9 0 RxSTS1OHFrame_11	O	CMOS	<p>Receive STS-1 TOH and POH Output Port - Frame Boundary Indicator:</p> <p>These output pins, along with RxSTS1OH_n, RxSTS1OHSel_n and RxSTS1OHClk_n function as the Receive STS-1 TOH and POH Output Port.</p> <p>These output pins will pulse "High" coincident with either of the following events.</p> <ol style="list-style-type: none"> 1. When the very first TOH byte (A1), of a given STS-1 frame, is being output via the corresponding RxSTS1OH_n output pin. 2. When the very first POH byte (J1), of a given STS-1 frame, is being output via the corresponding RxSTS1OH_n output pin. <p>NOTE: The external circuitry can determine whether these output pins are pulsing "High" for the first TOH or POH byte by checking the state of the corresponding RxSTS1OHSel_n output pin.</p>

STS-3/STM-1 TELECOM BUS INTERFACE - RECEIVE DIRECTION

PIN #	SIGNAL NAME	I/O	SIGNAL TYPE	DESCRIPTION
A20	STS3RxD_CLK_0 RxSBCIkLLOOP_0	O	CMOS	<p>Receive STS-3/STM-1 Telecom Bus Clock Output - Channel 0; LLOOP_0 (General Purpose) Output Pin:</p> <p>The function of this input pin depends upon whether or not the STS-3/STM-1 Telecom Bus Interface associated with Channel 0 is enabled.</p> <p>If STS-3/STM-1 Telecom Bus (Channel 0) has been enabled - STS-3/STM-1 Receive Telecom Bus Clock Output - Channel 0; STS3RxD_CLK_0:</p> <p>All signals, which is output via the Receive Telecom Bus - Channel 0 is clocked out upon the rising edge of this clock signal. This includes the following signals.</p> <ul style="list-style-type: none"> • STS3RxD_D_0[7:0] • STS3RxD_ALARM_0 • STS3RxD_DP_0 • STS3RxD_PL_0 • STS3RxD_C1J1_0 <p>This clock signal will operate at 19.44MHz.</p> <p>If STS-3/STM-1 Telecom Bus (Channel 0) is disabled - LLOOP_0 (General Purpose) Output Pin:</p> <p>This output pin can be used as a general purpose output pin. The state of this output pin can be controlled by writing the appropriate value into Bit 0 (LLOOP) within the Line Interface Drive Register associated with Channel 0 (Indirect Address = 0x1E, 0x80), (Direct Address = 0x1F80).</p> <p>NOTE: For Product Legacy purposes, this pin is called LLOOP_0 because one possible application is to tie this output pin to an LLOOP (Local Loop-back) input pin from one of Exar's XRT73L0X/XRT75L0X DS3/E3/STS-1 LIU devices. However, this output pin, and the corresponding register bit can be used for any purpose.</p>

STS-3/STM-1 TELECOM BUS INTERFACE - RECEIVE DIRECTION

PIN #	SIGNAL NAME	I/O	SIGNAL TYPE	DESCRIPTION
D23	STS3RxD_CLK_1 RxSBCikLLOOP_1	O	CMOS	<p>Receive STS-3/STM-1 Telecom Bus Clock Output - Channel 1; LLOOP_1 (General Purpose) Output Pin:</p> <p>The function of this input pin depends upon whether or not the STS-3/STM-1 Telecom Bus Interface associated with Channel 1 is enabled.</p> <p>If STS-3/STM-1 Telecom Bus (Channel 1) has been enabled - STS-3/STM-1 Receive Telecom Bus Clock Output - Channel 1; STS3RxD_CLK_1:</p> <p>All signals, which is output via the Receive Telecom Bus - Channel 1 is clocked out upon the rising edge of this clock signal. This includes the following signals.</p> <ul style="list-style-type: none"> • STS3RxD_D_1[7:0] • STS3RxD_ALARM_1 • STS3RxD_DP_1 • STS3RxD_PL_1 • STS3RxD_C1J1_1 <p>This clock signal will operate at 19.44MHz.</p> <p>If STS-3/STM-1 Telecom Bus (Channel 1) is disabled - LLOOP_1 (General Purpose) Output Pin:</p> <p>This output pin can be used as a general purpose output pin. The state of this output pin can be controlled by writing the appropriate value into Bit 0 (LLOOP) within the Line Interface Drive Register associated with Channel 1 (Indirect Address = 0x2E, 0x80), (Direct Address = 0x2F80).</p> <p>NOTE: For Product Legacy purposes, this pin is called LLOOP_1 because one possible application is to tie this output pin to an LLOOP (Local Loop-back) input pin from one of Exar's XRT73L0X/XRT75L0X DS3/E3/STS-1 LIU devices. However, this output pin, and the corresponding register bit can be used for any purpose.</p>

STS-3/STM-1 TELECOM BUS INTERFACE - RECEIVE DIRECTION

PIN #	SIGNAL NAME	I/O	SIGNAL TYPE	DESCRIPTION
W23	STS3RxD_CLK_2 RxSBCIkLLOOP_2	O	CMOS	<p>Receive STS-3/STM-1 Telecom Bus Clock Output - Channel 2; LLOOP_2 (General Purpose) Output Pin:</p> <p>The function of this input pin depends upon whether or not the STS-3/STM-1 Telecom Bus Interface associated with Channel 2 is enabled.</p> <p>If STS-3/STM-1 Telecom Bus (Channel 2) has been enabled - STS-3/STM-1 Receive Telecom Bus Clock Output - Channel 2; STS3RxD_CLK_2:</p> <p>All signals, which is output via the Receive Telecom Bus - Channel 2 is clocked out upon the rising edge of this clock signal. This includes the following signals.</p> <ul style="list-style-type: none"> • STS3RxD_D_2[7:0] • STS3RxD_ALARM_2 • STS3RxD_DP_2 • STS3RxD_PL_2 • STS3RxD_C1J1_2 <p>This clock signal will operate at 19.44MHz.</p> <p>If STS-3/STM-1 Telecom Bus (Channel 2) is disabled - LLOOP_2 (General Purpose) Output Pin:</p> <p>This output pin can be used as a general purpose output pin. The state of this output pin can be controlled by writing the appropriate value into Bit 0 (LLOOP) within the Line Interface Drive Register associated with Channel 2 (Indirect Address = 0x3E, 0x80), (Direct Address = 0x3F80).</p> <p>NOTE: For Product Legacy purposes, this pin is called LLOOP_2 because one possible application is to tie this output pin to an LLOOP (Local Loop-back) input pin from one of Exar's XRT73L0X/XRT75L0X DS3/E3/STS-1 LIU devices. However, this output pin, and the corresponding register bit can be used for any purpose.</p>

STS-3/STM-1 TELECOM BUS INTERFACE - RECEIVE DIRECTION

PIN #	SIGNAL NAME	I/O	SIGNAL TYPE	DESCRIPTION
AF20	STS3RxD_CLK_3 RxSBCikLLOOP_3	O	CMOS	<p>Receive STS-3/STM-1 Telecom Bus Clock Output - Channel 3; LLOOP_3 (General Purpose) Output Pin:</p> <p>The function of this input pin depends upon whether or not the STS-3/STM-1 Telecom Bus Interface associated with Channel 3 is enabled.</p> <p>If STS-3/STM-1 Telecom Bus (Channel 3) has been enabled - STS-3/STM-1 Receive Telecom Bus Clock Output - Channel 3; STS3RxD_CLK_3:</p> <p>All signals, which is output via the Receive Telecom Bus - Channel 3 is clocked out upon the rising edge of this clock signal. This includes the following signals.</p> <ul style="list-style-type: none"> • STS3RxD_D_3[7:0] • STS3RxD_ALARM_3 • STS3RxD_DP_3 • STS3RxD_PL_3 • STS3RxD_C1J1_3 <p>This clock signal will operate at 19.44MHz.</p> <p>If STS-3/STM-1 Telecom Bus (Channel 3) is disabled - LLOOP_3 (General Purpose) Output Pin:</p> <p>This output pin can be used as a general purpose output pin. The state of this output pin can be controlled by writing the appropriate value into Bit 0 (LLOOP) within the Line Interface Drive Register associated with Channel 3 (Indirect Address = 0x4E, 0x80), (Direct Address = 0x4F80).</p> <p>NOTE: For Product Legacy purposes, this pin is called LLOOP_3 because one possible application is to tie this output pin to an LLOOP (Local Loop-back) input pin from one of Exar's XRT73L0X/XRT75L0X DS3/E3/STS-1 LIU devices. However, this output pin, and the corresponding register bit can be used for any purpose.</p>

STS-3/STM-1 TELECOM BUS INTERFACE - RECEIVE DIRECTION

PIN #	SIGNAL NAME	I/O	SIGNAL TYPE	DESCRIPTION
A21	STS3RXD_PL_0 TAOS_0	O	CMOS	<p>STS-3/STM-1 Receive (Drop) Telecom Bus - Payload Indicator Output Signal - Channel 0/TAOS_0 (General Purpose) output Pin - Channel 0:</p> <p>The function of this output pin depends upon whether or not the STS-3/STM-1 Telecom Bus Interface block associated with Channel 0 has been enabled or disabled.</p> <p>If the STS-3/STM-1 Telecom Bus Interface (associated with Channel 0) is enabled - STS-3/STS-1 Receive (Drop) Telecom Bus - Payload Indicator Output - STS3RXD_PL_0:</p> <p>This output pin indicates whether or not Transport Overhead bytes are being output via the STS3RXD_D_0[7:0] output pins. This output pin is pulled "Low" for the duration that the STS-3/STM-1 Receive Telecom Bus is transmitting a Transport Overhead byte via the STS3RXD_D_0[7:0] output pins.</p> <p>Conversely, this output pin is pulled "High" for the duration that the STS-3/STM-1 Receive Telecom Bus is transmitting something other than a Transport Overhead byte via the STS3RXD_D_0[7:0] output pins.</p> <p>If the STS-3/STM-1 Telecom Bus Interface (associated with Channel 0) is disabled - TAOS_0 (General Purpose) output Pin - Channel 0:</p> <p>This output pin can be used as a general purpose output pin. The state of this output pin can be controlled by writing the appropriate value into Bit 4 (TAOS) within the Line Interface Drive Register associated with Channel 0 (Indirect Address = 0x1E, 0x80), (Direct Address = 0x1F80).</p> <p>NOTE: For Product Legacy purposes, this pin is called TAOS_0 because one possible application is to tie this output pin to an TAOS (Transmit All Ones) input pin from one of Exar's XRT73L0X/XRT75L0X DS3/E3/STS-1 LIU devices. However, this output pin, and the corresponding register bit can be used for any purpose.</p>

STS-3/STM-1 TELECOM BUS INTERFACE - RECEIVE DIRECTION

PIN #	SIGNAL NAME	I/O	SIGNAL TYPE	DESCRIPTION
D24	STS3RxD_PL_1 TAOS_1	O	CMOS	<p>STS-3/STM-1 Receive (Drop) Telecom Bus - Payload Indicator Output Signal - Channel 1/TAOS_1 (General Purpose) output Pin - Channel 1:</p> <p>The function of this output pin depends upon whether or not the STS-3/STM-1 Telecom Bus Interface block associated with Channel 1 has been enabled or disabled.</p> <p>If the STS-3/STM-1 Telecom Bus Interface (associated with Channel 1) is enabled - STS-3/STS-1 Receive (Drop) Telecom Bus - Payload Indicator Output - STS3RxD_PL_1:</p> <p>This output pin indicates whether or not Transport Overhead bytes are being output via the STS3RXD_D_1[7:0] output pins. This output pin is pulled "Low" for the duration that the STS-3/STM-1 Receive Telecom Bus is transmitting a Transport Overhead byte via the STS3RXD_D_1[7:0] output pins.</p> <p>Conversely, this output pin is pulled "High" for the duration that the STS-3/STM-1 Receive Telecom Bus is transmitting something other than a Transport Overhead byte via the STS3RXD_D_1[7:0] output pins.</p> <p>If the STS-3/STM-1 Telecom Bus Interface (associated with Channel 1) is disabled - TAOS_1 (General Purpose) output Pin - Channel 1:</p> <p>This output pin can be used as a general purpose output pin. The state of this output pin can be controlled by writing the appropriate value into Bit 4 (TAOS) within the Line Interface Drive Register associated with Channel 1 (Indirect Address = 0x2E, 0x80), (Direct Address = 0x2F80).</p> <p><i>NOTE: For Product Legacy purposes, this pin is called TAOS_1 because one possible application is to tie this output pin to an TAOS (Transmit All Ones) input pin from one of Exar's XRT73L0X/XRT75L0X DS3/E3/STS-1 LIU devices. However, this output pin, and the corresponding register bit can be used for any purpose.</i></p>

STS-3/STM-1 TELECOM BUS INTERFACE - RECEIVE DIRECTION

PIN #	SIGNAL NAME	I/O	SIGNAL TYPE	DESCRIPTION
V23	STS3RXD_PL_2 TAOS_2	O	CMOS	<p>STS-3/STM-1 Receive (Drop) Telecom Bus - Payload Indicator Output Signal - Channel 2/TAOS_2 (General Purpose) output Pin - Channel 2:</p> <p>The function of this output pin depends upon whether or not the STS-3/STM-1 Telecom Bus Interface block associated with Channel 2 has been enabled or disabled.</p> <p>If the STS-3/STM-1 Telecom Bus Interface (associated with Channel 2) is enabled - STS-3/STS-1 Receive (Drop) Telecom Bus - Payload Indicator Output - STS3RXD_PL_2:</p> <p>This output pin indicates whether or not Transport Overhead bytes are being output via the STS3RXD_D_2[7:0] output pins. This output pin is pulled "Low" for the duration that the STS-3/STM-1 Receive Telecom Bus is transmitting a Transport Overhead byte via the STS3RXD_D_2[7:0] output pins.</p> <p>Conversely, this output pin is pulled "High" for the duration that the STS-3/STM-1 Receive Telecom Bus is transmitting something other than a Transport Overhead byte via the STS3RXD_D_2[7:0] output pins.</p> <p>If the STS-3/STM-1 Telecom Bus Interface (associated with Channel 2) is disabled - TAOS_2 (General Purpose) output Pin - Channel 2:</p> <p>This output pin can be used as a general purpose output pin. The state of this output pin can be controlled by writing the appropriate value into Bit 4 (TAOS) within the Line Interface Drive Register associated with Channel 2 (Indirect Address = 0x3E, 0x80), (Direct Address = 0x3F80).</p> <p>NOTE: For Product Legacy purposes, this pin is called TAOS_2 because one possible application is to tie this output pin to an TAOS (Transmit All Ones) input pin from one of Exar's XRT73L0X/XRT75L0X DS3/E3/STS-1 LIU devices. However, this output pin, and the corresponding register bit can be used for any purpose.</p>

STS-3/STM-1 TELECOM BUS INTERFACE - RECEIVE DIRECTION

PIN #	SIGNAL NAME	I/O	SIGNAL TYPE	DESCRIPTION
AF21	STS3RxD_PL_3 TAOS_3	O	CMOS	<p>STS-3/STM-1 Receive (Drop) Telecom Bus - Payload Indicator Output Signal - Channel 3/TAOS_3 (General Purpose) output Pin - Channel 3:</p> <p>The function of this output pin depends upon whether or not the STS-3/STM-1 Telecom Bus Interface block associated with Channel 3 has been enabled or disabled.</p> <p>If the STS-3/STM-1 Telecom Bus Interface (associated with Channel 3) is enabled - STS-3/STS-1 Receive (Drop) Telecom Bus - Payload Indicator Output - STS3RxD_PL_3:</p> <p>This output pin indicates whether or not Transport Overhead bytes are being output via the STS3RXD_D_3[7:0] output pins. This output pin is pulled "Low" for the duration that the STS-3/STM-1 Receive Telecom Bus is transmitting a Transport Overhead byte via the STS3RXD_D_3[7:0] output pins.</p> <p>Conversely, this output pin is pulled "High" for the duration that the STS-3/STM-1 Receive Telecom Bus is transmitting something other than a Transport Overhead byte via the STS3RXD_D_3[7:0] output pins.</p> <p>If the STS-3/STM-1 Telecom Bus Interface (associated with Channel 3) is disabled - TAOS_3 (General Purpose) output Pin - Channel 3:</p> <p>This output pin can be used as a general purpose output pin. The state of this output pin can be controlled by writing the appropriate value into Bit 4 (TAOS) within the Line Interface Drive Register associated with Channel 3 (Indirect Address = 0x4E, 0x80), (Direct Address = 0x4F80) .</p> <p><i>NOTE: For Product Legacy purposes, this pin is called TAOS_3 because one possible application is to tie this output pin to an TAOS (Transmit All Ones) input pin from one of Exar's XRT73L0X/XRT75L0X DS3/E3/STS-1 LIU devices. However, this output pin, and the corresponding register bit can be used for any purpose.</i></p>

STS-3/STM-1 TELECOM BUS INTERFACE - RECEIVE DIRECTION

PIN #	SIGNAL NAME	I/O	SIGNAL TYPE	DESCRIPTION
C23	STS3RxD_C1J1_0 RxDS3FP_8 TxSTS1FP_8 RxSBFrame_0	O	CMOS	<p>STS-3/STM-1 Receive Telecom Bus - C1/J1 Byte Phase Indicator Output Signal - Channel 0; DS3/E3 Frame Synchronizer Framing Pulse Output Pin - Channel 8:</p> <p>The function of this output pin depends upon whether or not the STS-3/STM-1 Telecom Bus Interface for Channel 0 has been enabled.</p> <p>If STS-3/STM-1 Telecom Bus (Channel 0) has been enabled - STS-3/STM-1 Receive Telecom Bus - C1/J1 Byte Phase Indicator Output Signal:</p> <p>This output pin pulses "High" under the following two conditions.</p> <ol style="list-style-type: none"> 1. Whenever the C1 byte is being output via the STS3RxD_D_0[7:0] output, and 2. Whenever the J1 byte is being output via the STS3RxD_D_0[7:0] output. <p>NOTES:</p> <ol style="list-style-type: none"> 1. The STS-3/STM-1 Receive (Drop) Telecom Bus (associated with Channel 0) will indicate that it is transmitting the C1 byte (via the STS3RxD_D_0[7:0] output pins), by pulsing this output pin "High" (for one period of STS3RXD_CLK_0) and keeping the STS3RXD_PL_0 output pin pulled "Low". 2. The STS-3/STM-1 Receive (Drop) Telecom Bus (associated with Channel 0) will indicate that it is transmitting the J1 byte (via the STS3RxD_D_0[7:0] output pins), by pulsing this output pin "High" (for one period of STS3RXD_CLK_0) while the STS3TXD_PL_0 output pin is pulled "High". <p>If STS-3/STM-1 Telecom Bus (Channel 0) is disabled - RxDS3FP_8 (Receive DS3 Frame Pulse Input/Output - Channel 8):</p> <p>If the STS-3/STM-1 Telecom Bus (Channel 0) is disabled and if the DS3/E3 Framer block is enabled then this pin will function as the Receiving Framing Reference output pin. In this mode, the Frame Synchronizer block (associated with Channel 8) will pulse this output pin "High" for one DS3/E3 bit-period, coincident with the first bit (within a given DS3 or E3 frame) being output via the DS3/E3/STS1_Data_OUT_8 output pin.</p> <p>NOTE: This pin is inactive if the Frame Synchronizer block, associated with Channel 8 is by-passed.</p>

STS-3/STM-1 TELECOM BUS INTERFACE - RECEIVE DIRECTION

PIN #	SIGNAL NAME	I/O	SIGNAL TYPE	DESCRIPTION
J25	STS3RxD_C1J1_1 RxDS3FP_9 TxSTS1FP_9 RxSBFrame_1	O	CMOS	<p>STS-3/STM-1 Receive Telecom Bus - C1/J1 Byte Phase Indicator Output Signal - Channel 1; DS3/E3 Frame Synchronizer Framing Pulse Output Pin - Channel 9:</p> <p>The function of this output pin depends upon whether or not the STS-3/STM-1 Telecom Bus Interface for Channel 1 has been enabled.</p> <p>If STS-3/STM-1 Telecom Bus (Channel 1) has been enabled - STS-3/STM-1 Receive Telecom Bus - C1/J1 Byte Phase Indicator Output Signal:</p> <p>This output pin pulses "High" under the following two conditions.</p> <ol style="list-style-type: none"> 1. Whenever the C1 byte is being output via the STS3RxD_D_1[7:0] output. 2. Whenever the J1 byte is being output via the STS3RxD_D_1[7:0] output. <p>NOTES:</p> <ol style="list-style-type: none"> 1. The STS-3/STM-1 Receive (Drop) Telecom Bus (associated with Channel 1) will indicate that it is transmitting the C1 byte (via the STS3RxD_D_1[7:0] output pins), by pulsing this output pin "High" (for one period of STS3RXD_CLK_1) and keeping the STS3RXD_PL_1 output pin pulled "Low". 2. The STS-3/STM-1 Receive (Drop) Telecom Bus (associated with Channel 1) will indicate that it is transmitting the J1 byte (via the STS3RxD_D_1[7:0] output pins), by pulsing this output pin "High" (for one period of STS3RXD_CLK_1) while the STS3TXD_PL_1 output pin is pulled "High". <p>If STS-3/STM-1 Telecom Bus (Channel 1) is disabled - RxDS3FP_9 (Receive DS3 Frame Pulse Input/Output - Channel 9):</p> <p>If the STS-3/STM-1 Telecom Bus (Channel 1) is disabled and if the DS3/E3 Framer block is enabled then this pin will function as the Receiving Framing Reference output pin. In this mode, the Frame Synchronizer block (associated with Channel 9) will pulse this output pin "High" for one DS3/E3 bit-period, coincident with the first bit (within a given DS3 or E3 frame) being output via the DS3/E3/STS1_Data_OUT_9 output pin.</p> <p>NOTE: This pin is inactive if the Frame Synchronizer block, associated with Channel 9 is by-passed.</p>

STS-3/STM-1 TELECOM BUS INTERFACE - RECEIVE DIRECTION

PIN #	SIGNAL NAME	I/O	SIGNAL TYPE	DESCRIPTION
AC20	STS3RxD_C1J1_2 RxDS3FP_10 TxSTS1FP_10 RxSBFrame_2	O	CMOS	<p>STS-3/STM-1 Receive Telecom Bus - C1/J1 Byte Phase Indicator Output Signal - Channel 2; DS3/E3 Frame Synchronizer Framing Pulse Output Pin - Channel 10:</p> <p>The function of this output pin depends upon whether or not the STS-3/STM-1 Telecom Bus Interface for Channel 2 has been enabled.</p> <p>If STS-3/STM-1 Telecom Bus (Channel 2) has been enabled - STS-3/STM-1 Receive Telecom Bus - C1/J1 Byte Phase Indicator Output Signal:</p> <p>This output pin pulses "High" under the following two conditions.</p> <ol style="list-style-type: none"> 1. Whenever the C1 byte is being output via the STS3RxD_D_2[7:0] output, and 2. Whenever the J1 byte is being output via the STS3RxD_D_2[7:0] output. <p>NOTES:</p> <ol style="list-style-type: none"> 1. The STS-3/STM-1 Receive (Drop) Telecom Bus (associated with Channel 2) will indicate that it is transmitting the C1 byte (via the STS3RxD_D_2[7:0] output pins), by pulsing this output pin "High" (for one period of STS3RXD_CLK_2) and keeping the STS3RXD_PL_2 output pin pulled "Low". 2. The STS-3/STM-1 Receive (Drop) Telecom Bus (associated with Channel 2) will indicate that it is transmitting the J1 byte (via the STS3RxD_D_2[7:0] output pins), by pulsing this output pin "High" (for one period of STS3RXD_CLK_2) while the STS3TXD_PL_2 output pin is pulled "High". <p>If STS-3/STM-1 Telecom Bus (Channel 2) is disabled - RxDS3FP_10 (Receive DS3 Frame Pulse Input/Output - Channel 10):</p> <p>If the STS-3/STM-1 Telecom Bus (Channel 2) is disabled and if the DS3/E3 Framer block is enabled then this pin will function as the Receiving Framing Reference output pin. In this mode, the Frame Synchronizer block (associated with Channel 10) will pulse this output pin "High" for one DS3/E3 bit-period, coincident with the first bit (within a given DS3 or E3 frame) being output via the DS3/E3/STS1_Data_OUT_10 output pin.</p> <p>NOTE: This pin is inactive if the Frame Synchronizer block, associated with Channel 10 is by-passed.</p>

STS-3/STM-1 TELECOM BUS INTERFACE - RECEIVE DIRECTION

PIN #	SIGNAL NAME	I/O	SIGNAL TYPE	DESCRIPTION
AE14	STS3RxD_C1J1_3 RxDS3FP_11 TxSTS1FP_11 RxSBFrame_3	O	CMOS	<p>STS-3/STM-1 Receive Telecom Bus - C1/J1 Byte Phase Indicator Output Signal - Channel 3; DS3/E3 Frame Synchronizer Framing Pulse Output Pin - Channel 11:</p> <p>The function of this output pin depends upon whether or not the STS-3/STM-1 Telecom Bus Interface for Channel 3 has been enabled.</p> <p>If STS-3/STM-1 Telecom Bus (Channel 3) has been enabled - STS-3/STM-1 Receive Telecom Bus - C1/J1 Byte Phase Indicator Output Signal:</p> <p>This output pin pulses "High" under the following two conditions.</p> <ol style="list-style-type: none"> 1. Whenever the C1 byte is being output via the STS3RxD_D_3[7:0] output, and 2. Whenever the J1 byte is being output via the STS3RxD_D_3[7:0] output. <p>NOTES:</p> <ol style="list-style-type: none"> 1. The STS-3/STM-1 Receive (Drop) Telecom Bus (associated with Channel 3) will indicate that it is transmitting the C1 byte (via the STS3RxD_D_3[7:0] output pins), by pulsing this output pin "High" (for one period of STS3RXD_CLK_3) and keeping the STS3RXD_PL_3 output pin pulled "Low". 2. The STS-3/STM-1 Receive (Drop) Telecom Bus (associated with Channel 3) will indicate that it is transmitting the J1 byte (via the STS3RXD_D_3[7:0] output pins), by pulsing this output pin "High" (for one period of STS3RXD_CLK_3) while the STS3TXD_PL_3 output pin is pulled "High". <p>If STS-3/STM-1 Telecom Bus (Channel 3) is disabled - RxDS3FP_11 (Receive DS3 Frame Pulse Input/Output - Channel 11):</p> <p>If the STS-3/STM-1 Telecom Bus (Channel 3) is disabled and if the DS3/E3 Framer block is enabled then this pin will function as the Receiving Framing Reference output pin. In this mode, the Frame Synchronizer block (associated with Channel 11) will pulse this output pin "High" for one DS3/E3 bit-period, coincident with the first bit (within a given DS3 or E3 frame) being output via the DS3/E3/STS1_Data_OUT_11 output pin.</p> <p>NOTE: This pin is inactive if the Frame Synchronizer block, associated with Channel 11 is by-passed.</p>

STS-3/STM-1 TELECOM BUS INTERFACE - RECEIVE DIRECTION

PIN #	SIGNAL NAME	I/O	SIGNAL TYPE	DESCRIPTION
C22	STS3RXD_DP_0 RxDS3FP_4 TxSTS1FP_4	O	CMOS	<p>STS-3/STM-1 Receive (Drop) Telecom Bus - Parity Output Pin - Channel 0; DS3/E3 Frame Synchronizer Framing Pulse Output Pin - Channel 4:</p> <p>The function of this output pin depends upon whether or not the STS-3/STM-1 Telecom Bus Interface for Channel 0 has been enabled.</p> <p>If STS-3/STM-1 Telecom Bus (Channel 0) has been enabled - STS-3/STM-1 Receive Telecom Bus - Parity Output Pin:</p> <p>This output pin can be configured to function as one of the following.</p> <ol style="list-style-type: none"> 1. The EVEN or ODD parity value of the bits which are output via the STS3RXD_DP_0[7:0] output pins. 2. The EVEN or ODD parity value of the bits which are being output via the STS3RXD_DP_0[7:0] output pins and the states of the STS3RXD_PL_0 and STS3RXD_C1J1_0 output pins. <p>This output pin will ultimately be used (by drop-side circuitry) to verify the verify of the data which is output via the STS-3/STM-1 Telecom Bus Interface associated with Channel 0.</p> <p><i>NOTE: Any one of these configuration selections can be made by writing the appropriate value into the Telecom Bus Control Register (Indirect Address = 0x00, 0x3B), (Direct Address = 0x013B).</i></p> <p>If STS-3/STM-1 Telecom Bus (Channel 0) is disabled - RxDS3FP_4 (Receive DS3 Frame Pulse Input/Output - Channel 4):</p> <p>If the STS-3/STM-1 Telecom Bus (Channel 0) is disabled and if the DS3/E3 Framer block is enabled then this pin will function as the Receiving Framing Reference output pin. In this mode, the Frame Synchronizer block (associated with Channel 4) will pulse this output pin "High" for one DS3/E3 bit-period, coincident with the first bit (within a given DS3 or E3 frame) being output via the DS3/E3/STS1_Data_OUT_4 output pin.</p> <p><i>NOTE: This pin is inactive if the Frame Synchronizer block, associated with Channel 4 is by-passed.</i></p>

STS-3/STM-1 TELECOM BUS INTERFACE - RECEIVE DIRECTION

PIN #	SIGNAL NAME	I/O	SIGNAL TYPE	DESCRIPTION
G25	STS3RxD_DP_1 RxDS3FP_5 TxSTS1FP_5	O	CMOS	<p>STS-3/STM-1 Receive (Drop) Telecom Bus - Parity Output Pin - Channel 1; DS3/E3 Frame Synchronizer Framing Pulse Output Pin - Channel 5:</p> <p>The function of this output pin depends upon whether or not the STS-3/STM-1 Telecom Bus Interface for Channel 1 has been enabled.</p> <p>If STS-3/STM-1 Telecom Bus (Channel 1) has been enabled - STS-3/STM-1 Receive Telecom Bus - Parity Output Pin:</p> <p>This output pin can be configured to function as one of the following.</p> <ol style="list-style-type: none"> 1. The EVEN or ODD parity value of the bits which are output via the STS3RXD_D_1[7:0] output pins. 2. The EVEN or ODD parity value of the bits which are being output via the STS3RXD_D_1[7:0] output pins and the states of the STS3RXD_PL_1 and STS3RXD_C1J1_1 output pins. <p>This output pin will ultimately be used (by drop-side circuitry) to verify the verify of the data which is output via the STS-3/STM-1 Telecom Bus Interface associated with Channel 1.</p> <p><i>NOTE: Any one of these configuration selections can be made by writing the appropriate value into the Telecom Bus Control Register (Indirect Address = 0x00, 0x3A), (Direct Address = 0x013A).</i></p> <p>If STS-3/STM-1 Telecom Bus (Channel 1) is disabled - RxDS3FP_5 (Receive DS3 Frame Pulse Input/Output - Channel 5):</p> <p>If the STS-3/STM-1 Telecom Bus (Channel 1) is disabled and if the DS3/E3 Framer block is enabled then this pin will function as the Receiving Framing Reference output pin. In this mode, the Frame Synchronizer block (associated with Channel 5) will pulse this output pin "High" for one DS3/E3 bit-period, coincident with the first bit (within a given DS3 or E3 frame) being output via the DS3/E3/STS1_Data_OUT_5 output pin.</p> <p><i>NOTE: This pin is inactive if the Frame Synchronizer block, associated with Channel 5 is by-passed.</i></p>

STS-3/STM-1 TELECOM BUS INTERFACE - RECEIVE DIRECTION

PIN #	SIGNAL NAME	I/O	SIGNAL TYPE	DESCRIPTION
AC23	STS3RXD_DP_2 RxDS3FP_6 TxSTS1FP_6	O	CMOS	<p>STS-3/STM-1 Receive (Drop) Telecom Bus - Parity Output Pin - Channel 2; DS3/E3 Frame Synchronizer Framing Pulse Output Pin - Channel 6:</p> <p>The function of this output pin depends upon whether or not the STS-3/STM-1 Telecom Bus Interface for Channel 2 has been enabled.</p> <p>If STS-3/STM-1 Telecom Bus (Channel 2) has been enabled - STS-3/STM-1 Receive Telecom Bus - Parity Output Pin:</p> <p>This output pin can be configured to function as one of the following.</p> <ol style="list-style-type: none"> 1. The EVEN or ODD parity value of the bits which are output via the STS3RXD_D_2[7:0] output pins 2. The EVEN or ODD parity value of the bits which are being output via the STS3RXD_D_2[7:0] output pins and the states of the STS3RXD_PL_2 and STS3RXD_C1J1_2 output pins. <p>This output pin will ultimately be used (by drop-side circuitry) to verify the verify of the data which is output via the STS-3/STM-1 Telecom Bus Interface associated with Channel 2.</p> <p><i>NOTE: Any one of these configuration selections can be made by writing the appropriate value into the Telecom Bus Control Register (Indirect Address = 0x00, 0x39), (Direct Address = 0x0139).</i></p> <p>If STS-3/STM-1 Telecom Bus (Channel 2) is disabled - RxDS3FP_6 (Receive DS3 Frame Pulse Input/Output - Channel 6):</p> <p>If the STS-3/STM-1 Telecom Bus (Channel 2) is disabled and if the DS3/E3 Framer block is enabled then this pin will function as the Receiving Framing Reference output pin. In this mode, the Frame Synchronizer block (associated with Channel 6) will pulse this output pin "High" for one DS3/E3 bit-period, coincident with the first bit (within a given DS3 or E3 frame) being output via the DS3/E3/STS1_Data_OUT_6 output pin.</p> <p><i>NOTE: This pin is inactive if the Frame Synchronizer block, associated with Channel 6 is by-passed.</i></p>

STS-3/STM-1 TELECOM BUS INTERFACE - RECEIVE DIRECTION

PIN #	SIGNAL NAME	I/O	SIGNAL TYPE	DESCRIPTION
AC17	STS3RxD_DP_3 RxDS3FP_7 TxSTS1FP_7	O	CMOS	<p>STS-3/STM-1 Receive (Drop) Telecom Bus - Parity Output Pin - Channel 3; DS3/E3 Frame Synchronizer Framing Pulse Output Pin - Channel 7:</p> <p>The function of this output pin depends upon whether or not the STS-3/STM-1 Telecom Bus Interface for Channel 3 has been enabled.</p> <p>If STS-3/STM-1 Telecom Bus (Channel 3) has been enabled - STS-3/STM-1 Receive Telecom Bus - Parity Output Pin:</p> <p>This output pin can be configured to function as one of the following.</p> <ol style="list-style-type: none"> 1. The EVEN or ODD parity value of the bits which are output via the STS3RXD_D_3[7:0] output pins. 2. The EVEN or ODD parity value of the bits which are being output via the STS3RXD_D_3[7:0] output pins and the states of the STS3RXD_PL_3 and STS3RXD_C1J1_3 output pins. <p>This output pin will ultimately be used (by drop-side circuitry) to verify the verify of the data which is output via the STS-3/STM-1 Telecom Bus Interface associated with Channel 3.</p> <p><i>NOTE: Any one of these configuration selections can be made by writing the appropriate value into the Telecom Bus Control Register (Indirect Address = 0x00, 0x38), (Direct Address = 0x0138).</i></p> <p>If STS-3/STM-1 Telecom Bus (Channel 3) is disabled - RxDS3FP_7 (Receive DS3 Frame Pulse Input/Output - Channel 7):</p> <p>If the STS-3/STM-1 Telecom Bus (Channel 3) is disabled and if the DS3/E3 Framer block is enabled then this pin will function as the Receiving Framing Reference output pin. In this mode, the Frame Synchronizer block (associated with Channel 7) will pulse this output pin "High" for one DS3/E3 bit-period, coincident with the first bit (within a given DS3 or E3 frame) being output via the DS3/E3/STS1_Data_OUT_7 output pin.</p> <p><i>NOTE: This pin is inactive if the Frame Synchronizer block, associated with Channel 7 is by-passed.</i></p>

STS-3/STM-1 TELECOM BUS INTERFACE - RECEIVE DIRECTION

PIN #	SIGNAL NAME	I/O	SIGNAL TYPE	DESCRIPTION
C20	STS3RxD_Alarm_0 RxDS3FP_0 TxSTS1FP_0	O	CMOS	<p>STS-3/STM-1 Receive (Drop) Telecom Bus - Alarm Indicator Output signal - Channel 0; DS3/E3 Frame Synchronizer Framing Pulse Output Pin - Channel 0:</p> <p>The function of this output pin depends upon whether or not the STS-3/STM-1 Telecom Bus Interface for Channel 0 has been enabled.</p> <p>If STS-3/STM-1 Telecom Bus (Channel 0) has been enabled - STS-3/STM-1 Receive Telecom Bus - Alarm Indicator Output signal:</p> <p>This output pin pulses "High", coincident with any STS-1 signal (that is being output via the STS3RXD_D_0[7:0] output pins) that is carrying an AIS-P indicator.</p> <p>This output pin is "Low" for all other conditions.</p> <p>If STS-3/STM-1 Telecom Bus (Channel 0) is disabled - RxDS3FP_0 (Receive DS3 Frame Pulse Input/Output - Channel 0):</p> <p>If the STS-3/STM-1 Telecom Bus (Channel 0) is disabled and if the DS3/E3 Framer block is enabled then this pin will function as the Receiving Framing Reference output pin. In this mode, the Frame Synchronizer block (associated with Channel 0) will pulse this output pin "High" for one DS3/E3 bit-period, coincident with the first bit (within a given DS3 or E3 frame) being output via the DS3/E3/STS1_Data_OUT_0 output pin.</p> <p><i>NOTE: This pin is inactive if the Frame Synchronizer block, associated with Channel 0 is by-passed.</i></p>
E25	STS3RxD_Alarm_1 RxDS3FP_1 TxSTS1FP_1	O	CMOS	<p>STS-3/STM-1 Receive (Drop) Telecom Bus - Alarm Indicator Output signal - Channel 1; DS3/E3 Frame Synchronizer Framing Pulse Output Pin - Channel 1:</p> <p>The function of this output pin depends upon whether or not the STS-3/STM-1 Telecom Bus Interface for Channel 1 has been enabled.</p> <p>If STS-3/STM-1 Telecom Bus (Channel 1) has been enabled - STS-3/STM-1 Receive Telecom Bus - Alarm Indicator Output signal:</p> <p>This output pin pulses "High", coincident with any STS-1 signal (that is being output via the STS3RXD_D_1[7:0] output pins) that is carrying an AIS-P indicator.</p> <p>This output pin is "Low" for all other conditions.</p> <p>If STS-3/STM-1 Telecom Bus (Channel 1) is disabled - RxDS3FP_1 (Receive DS3 Frame Pulse Input/Output - Channel 1):</p> <p>If the STS-3/STM-1 Telecom Bus (Channel 1) is disabled and if the DS3/E3 Framer block is enabled then this pin will function as the Receiving Framing Reference output pin. In this mode, the Frame Synchronizer block (associated with Channel 1) will pulse this output pin "High" for one DS3/E3 bit-period, coincident with the first bit (within a given DS3 or E3 frame) being output via the DS3/E3/STS1_Data_OUT_1 output pin.</p> <p><i>NOTE: This pin is inactive if the Frame Synchronizer block, associated with Channel 1 is by-passed.</i></p>

STS-3/STM-1 TELECOM BUS INTERFACE - RECEIVE DIRECTION

PIN #	SIGNAL NAME	I/O	SIGNAL TYPE	DESCRIPTION
V21	STS3RxD_Alarm_2 RxDS3FP_2 TxSTS1FP_2	O	CMOS	<p>STS-3/STM-1 Receive (Drop) Telecom Bus - Alarm Indicator Output signal - Channel 2; DS3/E3 Frame Synchronizer Framing Pulse Output Pin - Channel 2:</p> <p>The function of this output pin depends upon whether or not the STS-3/STM-1 Telecom Bus Interface for Channel 2 has been enabled.</p> <p>If STS-3/STM-1 Telecom Bus (Channel 2) has been enabled - STS-3/STM-1 Receive Telecom Bus - Alarm Indicator Output signal:</p> <p>This output pin pulses "High", coincident with any STS-1 signal (that is being output via the STS3RXD_D_2[7:0] output pins) that is carrying an AIS-P indicator.</p> <p>This output pin is "Low" for all other conditions.</p> <p>If STS-3/STM-1 Telecom Bus (Channel 2) is disabled - RxDS3FP_2 (Receive DS3 Frame Pulse Input/Output - Channel 2):</p> <p>If the STS-3/STM-1 Telecom Bus (Channel 2) is disabled and if the DS3/E3 Framer block is enabled then this pin will function as the Receiving Framing Reference output pin. In this mode, the Frame Synchronizer block (associated with Channel 2) will pulse this output pin "High" for one DS3/E3 bit-period, coincident with the first bit (within a given DS3 or E3 frame) being output via the DS3/E3/STS1_Data_OUT_2 output pin.</p> <p><i>NOTE: This pin is inactive if the Frame Synchronizer block, associated with Channel 2 is by-passed.</i></p>
AD21	STS3RxD_Alarm_3 RxDS3FP_3 TxSTS1FP_3	O	CMOS	<p>STS-3/STM-1 Receive (Drop) Telecom Bus - Alarm Indicator Output signal - Channel 3; DS3/E3 Frame Synchronizer Framing Pulse Output Pin - Channel 3:</p> <p>The function of this output pin depends upon whether or not the STS-3/STM-1 Telecom Bus Interface for Channel 3 has been enabled.</p> <p>If STS-3/STM-1 Telecom Bus (Channel 3) has been enabled - STS-3/STM-1 Receive Telecom Bus - Alarm Indicator Output signal:</p> <p>This output pin pulses "High", coincident with any STS-1 signal (that is being output via the STS3RXD_D_3[7:0] output pins) that is carrying an AIS-P indicator.</p> <p>This output pin is "Low" for all other conditions.</p> <p>If STS-3/STM-1 Telecom Bus (Channel 3) is disabled - RxDS3FP_3 (Receive DS3 Frame Pulse Input/Output - Channel 3):</p> <p>If the STS-3/STM-1 Telecom Bus (Channel 3) is disabled and if the DS3/E3 Framer block is enabled then this pin will function as the Receiving Framing Reference output pin. In this mode, the Frame Synchronizer block (associated with Channel 3) will pulse this output pin "High" for one DS3/E3 bit-period, coincident with the first bit (within a given DS3 or E3 frame) being output via the DS3/E3/STS1_Data_OUT_3 output pin.</p> <p><i>NOTE: This pin is inactive if the Frame Synchronizer block, associated with Channel 3 is by-passed.</i></p>

STS-3/STM-1 TELECOM BUS INTERFACE - RECEIVE DIRECTION

PIN #	SIGNAL NAME	I/O	SIGNAL TYPE	DESCRIPTION
B21	STS3RxD_D_0_0 TxLEV_0 RxSBDData_0	O	CMOS	<p>Receive STS-3/STM-1 Telecom Bus - Channel 0 - Output Data Bus Pin Number 0/TxLEV_0 (General Purpose) Output pin:</p> <p>The function of this output pin depends upon whether or not the STS-3/STM-1 Telecom Bus Interface, associated with Channel 0 is enabled.</p> <p>If STS-3/STM-1 Telecom Bus (Channel 0) has been enabled - STS-3/STM-1 Receive Telecom Bus - Output Data bus Pin Number 0: STSRxD_D_0_0:</p> <p>This output pin along with STS3RxD_D_0[7:1] function as the STS-3/STM-1 Receive (Drop) Telecom Bus - Output Data Bus for Channel 0. The STS-3/STM-1 Telecom Bus Interface will update the data via this output upon the rising edge of STS3RxD_CLK_0.</p> <p><i>NOTE: This input pin functions as the LSB (Least Significant Bit) of the Receive (Drop) Telecom Bus for Channel 0.</i></p> <p>If STS-3/STM-1 Telecom Bus (Channel 0) is disabled - TXLEV_0 (General Purpose) output Pin.</p> <p>This output pin can be used as a general purpose output pin. The state of this output pin can be controlled by writing the appropriate value into Bit 2 (TxLEV) within the Line Interface Drive Register associated with Channel 0 (Indirect Address = 0x1E, 0x80), (Direct Address = 0x1F80).</p> <p><i>NOTE: For Product Legacy purposes, this pin is called TxLEV_0 because one possible application is to tie this output pin to a TxLEV (Transmit Line Build-Out Disable) input pin from one of Exar's XRT73L0X/ XRT75L0X DS3/E3/STS-1 LIU devices. However, this output pin, and the corresponding register bit can be used for any purpose.</i></p>

STS-3/STM-1 TELECOM BUS INTERFACE - RECEIVE DIRECTION

PIN #	SIGNAL NAME	I/O	SIGNAL TYPE	DESCRIPTION
B20	STS3RxD_D_0_1 ENCODIS_0 RxSBData_1	O	CMOS	<p>Receive STS-3/STM-1 Telecom Bus - Channel 0 - Output Data Bus Pin Number 1/ENCODIS_0 (General Purpose) Output Pin:</p> <p>The function of this output pin depends upon whether or not the STS-3/STM-1 Telecom Bus Interface, associated with Channel 0 is enabled.</p> <p>If STS-3/STM-1 Telecom Bus (Channel 0) has been enabled - STS-3/STM-1 Receive Telecom Bus - Output Data bus Pin Number 1: STSRxD_D_0_1:</p> <p>This output pin along with STS3RxD_D_0[7:2] and STS3RxD_D_0_0 function as the STS-3/STM-1 Receive (Drop) Telecom Bus - Output Data Bus for Channel 0. The STS-3/STM-1 Telecom Bus Interface will update the data via this output upon the rising edge of STS3RxD_CLK_0.</p> <p>If STS-3/STM-1 Telecom Bus (Channel 0) is disabled - ENCODIS_0 (General Purpose) output Pin.</p> <p>This output pin can be used as a general purpose output pin. The state of this output pin can be controlled by writing the appropriate value into Bit 3 (ENCODIS) within the Line Interface Drive Register associated with Channel 0 (Indirect Address = 0x1E, 0x80), (Direct Address = 0x1F80).</p> <p>NOTE: For Product Legacy purposes, this pin is called ENCODIS_0 because one possible application is to tie this output pin to an ENCODIS (B3ZS/HDB3 Encoder Disable) input pin from one of Exar's XRT73L0X/ XRT75L0X DS3/E3/STS-1 LIU devices. However, this output pin, and the corresponding register bit can be used for any purpose.</p>

STS-3/STM-1 TELECOM BUS INTERFACE - RECEIVE DIRECTION

PIN #	SIGNAL NAME	I/O	SIGNAL TYPE	DESCRIPTION
E20	STS3RxD_D_0_2 DS3/E3/ STS1_Data_OUT_0 RxSBDData_2	O	CMOS	<p>Receive STS-3/STM-1 Telecom Bus - Channel 0 - Output Data Bus Pin Number 2/DS3/E3 Framer or Transmit STS-1 TOH Processor block line interface output Pin - Channel 0 (DS3/E3/STS1_DATA_OUT_0):</p> <p>The function of this output pin depends upon whether or not the STS-3/STM-1 Telecom Bus Interface, associated with Channel 0 is enabled.</p> <p>If STS-3/STM-1 Telecom Bus (Channel 0) has been enabled - STS-3/STM-1 Receive Telecom Bus - Output Data bus Pin Number 2: STSRxD_D_0_2:</p> <p>This output pin along with STS3RxD_D_0[7:3] and STS3RxD_D_0[1:0] function as the STS-3/STM-1 Receive (Drop) Telecom Bus - Output Data Bus for Channel 0. The STS-3/STM-1 Telecom Bus Interface will update the data via this output upon the rising edge of STS3RxD_CLK_0.</p> <p>If STS-3/STM-1 Telecom Bus (Channel 0) is disabled - DS3/E3/STS1_DATA_OUT Line Interface Data output Pin - Channel 0:</p> <p>This pin outputs single-rail DS3, E3 or STS-1 data to a DS3/E3/STS-1 LIU IC. This output pin should be connected to the TPOS/TDATA input of the DS3/E3/STS-1 LIU IC (corresponding to Channel 0). By default, the data that is output via this output pin will be updated upon the rising edge of DS3/E3/STS1_CLK_OUT_0 signal pin number C21.</p> <p>For DS3/E3 Applications</p> <p>The XRT94L43 can be configured to update this output signal upon the falling edge of the DS3/E3/STS1_CLK_0 signal by setting Bit 2 (DS3/E3/STS1_CLK_OUT Invert), within the I/O Control Register - Channel 0 (Indirect Address = 0x1E, 0x01), (Direct Address = 0x1F01) to a "1".</p> <p>For STS-1 Applications</p> <p>The XRT94L43 can not be configured to update the DS3/E3/STS1_DATA_OUT_0 signal upon the falling edge of DS3/E3/STS1_CLK_OUT_0.</p>

STS-3/STM-1 TELECOM BUS INTERFACE - RECEIVE DIRECTION

PIN #	SIGNAL NAME	I/O	SIGNAL TYPE	DESCRIPTION
D20	STS3RxD_D_0_3 DS3/E3/ STS1_Data_OUT_4 RxSBData_3	O	CMOS	<p>Receive STS-3/STM-1 Telecom Bus - Channel 0 - Output Data Bus Pin Number 3/DS3/E3 Framer or Transmit STS-1 TOH Processor block line interface output Pin - Channel 4 (DS3/E3/STS1_DATA_OUT_4):</p> <p>The function of this output pin depends upon whether or not the STS-3/STM-1 Telecom Bus Interface, associated with Channel 0 is enabled.</p> <p>If STS-3/STM-1 Telecom Bus (Channel 0) has been enabled - STS-3/STM-1 Receive Telecom Bus - Output Data bus Pin Number 3: STSRxD_D_0_3:</p> <p>This output pin along with STS3RxD_D_0[7:4] and STS3RxD_D_0[2:0] function as the STS-3/STM-1 Receive (Drop) Telecom Bus - Output Data Bus for Channel 0. The STS-3/STM-1 Telecom Bus Interface will update the data via this output upon the rising edge of STS3RxD_CLK_0.</p> <p>If STS-3/STM-1 Telecom Bus (Channel 0) is disabled - DS3/E3/STS1_DATA_OUT Line Interface Data output Pin - Channel 4:</p> <p>This pin outputs single-rail DS3, E3 or STS-1 data to a DS3/E3/STS-1 LIU IC. This output pin should be connected to the TPOS/TDATA input of the DS3/E3/STS-1 LIU IC (corresponding to Channel 4). By default, the data that is output via this output pin will be updated upon the rising edge of the DS3/E3/STS1_CLK_OUT_4 signal pin number E21.</p> <p>For DS3/E3 Applications</p> <p>The XRT94L43 can be configured to update this output signal upon the falling edge of the DS3/E3/STS1_CLK_4 signal by setting Bit 2 (DS3/E3/STS1_CLK_OUT Invert), within the I/O Control Register - Channel 4 (Indirect Address = 0x5E, 0x01), (Direct Address = 0x5F01) to a "1".</p> <p>For STS-1 Applications</p> <p>The XRT94L43 can not be configured to update the DS3/E3/STS1_DATA_OUT_4 signal upon the falling edge of DS3/E3/STS1_CLK_OUT_4.</p>

STS-3/STM-1 TELECOM BUS INTERFACE - RECEIVE DIRECTION

PIN #	SIGNAL NAME	I/O	SIGNAL TYPE	DESCRIPTION
D21	STS3RxD_D_0_4 DS3/E3/ STS1_Data_OUT_8 RxSBDData_4	O	CMOS	<p>Receive STS-3/STM-1 Telecom Bus - Channel 0 - Output Data Bus Pin Number 4/DS3/E3 Framer or Transmit STS-1 TOH Processor block line interface output Pin - Channel 8 (DS3/E3/STS1_DATA_OUT_8):</p> <p>The function of this output pin depends upon whether or not the STS-3/STM-1 Telecom Bus Interface, associated with Channel 0 is enabled.</p> <p>If STS-3/STM-1 Telecom Bus (Channel 0) has been enabled - STS-3/STM-1 Receive Telecom Bus - Output Data bus Pin Number 4: STSRxD_D_0_4:</p> <p>This output pin along with STS3RxD_D_0[7:5] and STS3RxD_D_0[3:0] function as the STS-3/STM-1 Receive (Drop) Telecom Bus - Output Data Bus for Channel 0. The STS-3/STM-1 Telecom Bus Interface will update the data via this output upon the rising edge of STS3RxD_CLK_0.</p> <p>If STS-3/STM-1 Telecom Bus (Channel 0) is disabled - DS3/E3/STS1_DATA_OUT Line Interface Data output Pin - Channel 8:</p> <p>This pin outputs single-rail DS3, E3 or STS-1 data to a DS3/E3/STS-1 LIU IC. This output pin should be connected to the TPOS/TDATA input of the DS3/E3/STS-1 LIU IC (corresponding to Channel 8). By default, the data that is being output via this output pin will be updated upon the rising edge of the DS3/E3/STS-1_CLK_OUT_8 signal pin number C24.</p> <p>For DS3/E3 Applications</p> <p>The XRT94L43 can be configured to update the DS3/E3/STS1_DATA_8 output signal upon the falling edge of the DS3/E3/STS1_CLK_8 signal by setting Bit 2 (DS3/E3/STS1_CLK_OUT Invert), within the I/O Control Register - Channel 8 (Indirect Address = 0x9E, 0x01), (Direct Address = 0x9F01) to a "1".</p> <p>For STS-1 Applications</p> <p>The XRT94L43 can not be configured to update the DS3/E3/STS1_DATA_OUT_8 signal upon the falling edge of DS3/E3/STS1_CLK_OUT_8.</p>

STS-3/STM-1 TELECOM BUS INTERFACE - RECEIVE DIRECTION

PIN #	SIGNAL NAME	I/O	SIGNAL TYPE	DESCRIPTION
C21	STS3RxD_D_0_5 DS3/E3/STS1_CLK_OUT_0 RxSBDData_5	O	CMOS	<p>Receive STS-3/STM-1 Telecom Bus - Channel 0 - Output Data Bus Pin Number 5/DS3/E3 Framer or Transmit STS-1 TOH Processor block line interface clock output Pin - Channel 0: (DS3/E3/STS1_CLK_OUT_0):</p> <p>The function of this output pin depends upon whether or not the STS-3/STM-1 Telecom Bus Interface, associated with Channel 0 is enabled.</p> <p>If STS-3/STM-1 Telecom Bus (Channel 0) has been enabled - STS-3/STM-1 Receive Telecom Bus - Output Data bus Pin Number 5: STSRxD_D_0_5:</p> <p>This output pin along with STS3RxD_D_0[7:6] and STS3RxD_D_0[4:0] function as the STS-3/STM-1 Receive (Drop) Telecom Bus - Output Data Bus for Channel 0. The STS-3/STM-1 Telecom Bus Interface will update the data via this output upon the rising edge of STS3RxD_CLK_0.</p> <p>If STS-3/STM-1 Telecom Bus (Channel 0) is disabled - DS3/E3/STS1_CLK_OUT Line Interface Clock output Pin - Channel 0:</p> <p>This pin outputs a DS3, E3 or STS-1 rate clock signal to a DS3/E3/STS-1 LIU IC. This output pin should be connected to the TxCLK input of the DS3/E3/STS-1 LIU IC (corresponding to Channel 0).</p> <p>By default, the data, which is being output via the DS3/E3/STS1_DATA_OUT_0 output pin will be updated upon the rising edge of this clock output signal.</p> <p>For DS3/E3 Applications</p> <p>The XRT94L43 can be configured to update the DS3/E3/STS1_DATA_0 output signal upon the falling edge of the DS3/E3/STS1_CLK_0 signal by setting Bit 0 (DS3/E3/STS1_CLK_OUT Invert), within the I/O Control Register - Channel 0 (Indirect Address = 0x1E, 0x01), (Direct Address = 0x1F01) to a "1".</p> <p>For STS-1 Applications</p> <p>The XRT94L43 can not be configured to update the DS3/E3/STS1_DATA_OUT_0 signal upon the falling edge of DS3/E3/STS1_CLK_0.</p>

STS-3/STM-1 TELECOM BUS INTERFACE - RECEIVE DIRECTION

PIN #	SIGNAL NAME	I/O	SIGNAL TYPE	DESCRIPTION
E21	STS3RxD_D_0_6 DS3/E3/STS1_Clk_OUT_4 RxSBDData_6	O	CMOS	<p>Receive STS-3/STM-1 Telecom Bus - Channel 0 - Output Data Bus Pin Number 6/DS3/E3 Framer or Transmit STS-1 TOH Processor block line interface clock output Pin - Channel 4: (DS3/E3/STS1_CLK_OUT_4):</p> <p>The function of this output pin depends upon whether or not the STS-3/STM-1 Telecom Bus Interface, associated with Channel 0 is enabled.</p> <p>If STS-3/STM-1 Telecom Bus (Channel 0) has been enabled - STS-3/STM-1 Receive Telecom Bus - Output Data bus Pin Number 6: STSRxD_D_0_6:</p> <p>This output pin along with STS3RxD_D_0_7 and STS3RxD_D_0[5:0] function as the STS-3/STM-1 Receive (Drop) Telecom Bus - Output Data Bus for Channel 0. The STS-3/STM-1 Telecom Bus Interface will update the data via this output upon the rising edge of STS3RxD_CLK_0.</p> <p>If STS-3/STM-1 Telecom Bus (Channel 0) is disabled - DS3/E3/STS1_CLK_OUT Line Interface Clock output Pin - Channel 4:</p> <p>This pin outputs a DS3, E3 or STS-1 rate clock signal to a DS3/E3/STS-1 LIU IC. This output pin should be connected to the TxCLK input of the DS3/E3/STS-1 LIU IC (corresponding to Channel 4).</p> <p>By default, the data, which is being output via the DS3/E3/STS1_DATA_OUT_4 output pin will be updated upon the rising edge of this clock output signal.</p> <p>For DS3/E3 Applications</p> <p>The XRT94L43 can be configured to update the DS3/E3/STS1_DATA_4 output signal upon the falling edge of the DS3/E3/STS1_CLK_4 signal by setting Bit 0 (DS3/E3/STS1_CLK_OUT Invert), within the I/O Control Register - Channel 4 (Indirect Address = 0x5E, 0x01), (Direct Address = 0x5F01) to a "1".</p> <p>For STS-1 Applications</p> <p>The XRT94L43 can not be configured to update the DS3/E3/STS1_DATA_OUT_4 signal upon the falling edge of DS3/E3/STS1_CLK_4.</p>

STS-3/STM-1 TELECOM BUS INTERFACE - RECEIVE DIRECTION

PIN #	SIGNAL NAME	I/O	SIGNAL TYPE	DESCRIPTION
C24	STS3RxD_D_0_7 DS3/E3/STS1_Clk_OUT_8 RxSBDData_7	O	CMOS	<p>Receive STS-3/STM-1 Telecom Bus - Channel 0 - Output Data Bus Pin Number 7/DS3/E3 Framer or Transmit STS-1 TOH Processor block line interface clock output Pin - Channel 8: (DS3/E3/STS1_CLK_OUT_8):</p> <p>The function of this output pin depends upon whether or not the STS-3/STM-1 Telecom Bus Interface, associated with Channel 0 is enabled.</p> <p>If STS-3/STM-1 Telecom Bus (Channel 0) has been enabled - STS-3/STM-1 Receive Telecom Bus - Output Data bus Pin Number 7: STSRxD_D_0_7:</p> <p>This output pin along with STS3RxD_D_0[6:0] function as the STS-3/STM-1 Receive (Drop) Telecom Bus - Output Data Bus for Channel 0. The STS-3/STM-1 Telecom Bus Interface will update the data via this output upon the rising edge of STS3RxD_CLK_0.</p> <p><i>NOTE: This output pin functions as the MSB (Most Significant Bit) for the STS-3/STM-1 Receive (Drop) Telecom Bus Interface - Output Data Bus (Channel 0).</i></p> <p>If STS-3/STM-1 Telecom Bus (Channel 0) is disabled - DS3/E3/STS1_CLK_OUT Line Interface Clock output Pin - Channel 8:</p> <p>This pin outputs a DS3, E3 or STS-1 rate clock signal to a DS3/E3/STS-1 LIU IC. This output pin should be connected to the TxCLK input of the DS3/E3/STS-1 LIU IC (corresponding to Channel 8).</p> <p>By default, the data, which is being output via the DS3/E3/STS1_DATA_OUT_8 output pin will be updated upon the rising edge of this clock output signal.</p> <p>For DS3/E3 Applications</p> <p>The XRT94L43 can be configured to update the DS3/E3/STS1_DATA_8 output signal upon the falling edge of the DS3/E3/STS1_CLK_8 signal by setting Bit 0 (DS3/E3/STS1_CLK_OUT Invert), within the I/O Control Register - Channel 8 (Indirect Address = 0x9E, 0x01), (Direct Address = 0x9F01) to a "1".</p> <p>For STS-1 Applications</p> <p>The XRT94L43 can not be configured to update the DS3/E3/STS1_DATA_OUT_8 signal upon the falling edge of DS3/E3/STS1_CLK_8.</p>

STS-3/STM-1 TELECOM BUS INTERFACE - RECEIVE DIRECTION

PIN #	SIGNAL NAME	I/O	SIGNAL TYPE	DESCRIPTION
E24	STS3RxD_D_1_0 TxLEV_1 RxSBDData_0	O	CMOS	<p>Receive STS-3/STM-1 Telecom Bus - Channel 1 - Output Data Bus Pin Number 0/TxLEV_1 (General Purpose) Output Pin:</p> <p>The function of this output pin depends upon whether or not the STS-3/STM-1 Telecom Bus Interface, associated with Channel 1 is enabled.</p> <p>If STS-3/STM-1 Telecom Bus (Channel 1) has been enabled - STS-3/STM-1 Receive Telecom Bus - Output Data bus Pin Number 0: STSRxD_D_1_0:</p> <p>This output pin along with STS3RxD_D_1[7:1] function as the STS-3/STM-1 Receive (Drop) Telecom Bus - Output Data Bus for Channel 1. The STS-3/STM-1 Telecom Bus Interface will update the data via this output upon the rising edge of STS3RxD_CLK_1.</p> <p><i>NOTE: This input pin functions as the LSB (Least Significant Bit) of the Receive (Drop) Telecom Bus for Channel 1.</i></p> <p>If STS-3/STM-1 Telecom Bus (Channel 1) is disabled - TXLEV_1 (General Purpose) output Pin:</p> <p>This output pin can be used as a general purpose output pin. The state of this output pin can be controlled by writing the appropriate value into Bit 2 (TxLEV) within the Line Interface Drive Register associated with Channel 1 (Indirect Address = 0x2E, 0x80), (Direct Address = 0x2F80).</p> <p><i>NOTE: For Product Legacy purposes, this pin is called TxLEV_1 because one possible application is to tie this output pin to a TxLEV (Transmit Line Build-Out Disable) input pin from one of Exar's XRT73L0X/ XRT75L0X DS3/E3/STS-1 LIU devices. However, this output pin, and the corresponding register bit can be used for any purpose.</i></p>

STS-3/STM-1 TELECOM BUS INTERFACE - RECEIVE DIRECTION

PIN #	SIGNAL NAME	I/O	SIGNAL TYPE	DESCRIPTION
E23	STS3RxD_D_1_1 ENCODIS_1 RxSBData_1	O	CMOS	<p>Receive STS-3/STM-1 Telecom Bus - Channel 1 - Output Data Bus Pin Number 1/ENCODIS_1 (General Purpose) Output Pin:</p> <p>The function of this output pin depends upon whether or not the STS-3/STM-1 Telecom Bus Interface, associated with Channel 1 is enabled.</p> <p>If STS-3/STM-1 Telecom Bus (Channel 1) has been enabled - STS-3/STM-1 Receive Telecom Bus - Output Data bus Pin Number 1: STSRxD_D_1_1:</p> <p>This output pin along with STS3RxD_D_1[7:2] and STS3RxD_D_1_0 function as the STS-3/STM-1 Receive (Drop) Telecom Bus - Output Data Bus for Channel 1. The STS-3/STM-1 Telecom Bus Interface will update the data via this output upon the rising edge of STS3RxD_CLK_1.</p> <p>If STS-3/STM-1 Telecom Bus (Channel 1) is disabled - ENCODIS_1 (General Purpose) output Pin:</p> <p>This output pin can be used as a general purpose output pin. The state of this output pin can be controlled by writing the appropriate value into Bit 3 (ENCODIS) within the Line Interface Drive Register associated with Channel 1 (Indirect Address = 0x2E, 0x80), (Direct Address = 0x2F80).</p> <p>NOTE: For Product Legacy purposes, this pin is called ENCODIS_1 because one possible application is to tie this output pin to an ENCODIS (B3ZS/HDB3 Encoder Disable) input pin from one of Exar's XRT73L0X/ XRT75L0X DS3/E3/STS-1 LIU devices. However, this output pin, and the corresponding register bit can be used for any purpose.</p>

STS-3/STM-1 TELECOM BUS INTERFACE - RECEIVE DIRECTION

PIN #	SIGNAL NAME	I/O	SIGNAL TYPE	DESCRIPTION
F26	STS3RxD_D_1_2 DS3/E3/ STS1_Data_OUT_1 RxSBDData_2	O	CMOS	<p>Receive STS-3/STM-1 Telecom Bus - Channel 1 - Output Data Bus Pin Number 2/DS3/E3 Framer or Transmit STS-1 TOH Processor block line interface output Pin - Channel 1 (DS3/E3/STS1_DATA_OUT_1):</p> <p>The function of this output pin depends upon whether or not the STS-3/STM-1 Telecom Bus Interface, associated with Channel 1 is enabled.</p> <p>If STS-3/STM-1 Telecom Bus (Channel 1) has been enabled - STS-3/STM-1 Receive Telecom Bus - Output Data bus Pin Number 2: STSRxD_D_1_2:</p> <p>This output pin along with STS3RxD_D_1[7:3] and STS3RxD_D_1[1:0] function as the STS-3/STM-1 Receive (Drop) Telecom Bus - Output Data Bus for Channel 1. The STS-3/STM-1 Telecom Bus Interface will update the data via this output upon the rising edge of STS3RxD_CLK_1.</p> <p>If STS-3/STM-1 Telecom Bus (Channel 1) is disabled - DS3/E3/STS1_DATA_OUT Line Interface Data output Pin - Channel 1:</p> <p>This pin outputs single-rail DS3, E3 or STS-1 data to a DS3/E3/STS-1 LIU IC. This output pin should be connected to the TPOS/TDATA input of the DS3/E3/STS-1 LIU IC (corresponding to Channel 1). By default, the data that is output via this output pin will be updated upon the rising edge of the DS3/E3/STS1_CLK_OUT_1 signal pin number G26.</p> <p>For DS3/E3 Applications</p> <p>The XRT94L43 can be configured to update this output signal upon the falling edge of the DS3/E3/STS1_CLK_1 signal by setting Bit 2 (DS3/E3/STS1_CLK_OUT Invert), within the I/O Control Register - Channel 1 (Indirect Address = 0x2E, 0x01), (Direct Address = 0x2F01) to a "1".</p> <p>For STS-1 Applications</p> <p>The XRT94L43 can not be configured to update the DS3/E3/STS1_DATA_OUT_1 signal upon the falling edge of DS3/E3/STS1_CLK_OUT_1.</p>

STS-3/STM-1 TELECOM BUS INTERFACE - RECEIVE DIRECTION

PIN #	SIGNAL NAME	I/O	SIGNAL TYPE	DESCRIPTION
H26	STS3RxD_D_1_3 DS3/E3/ STS1_Data_OUT_5 RxSBData_3	O	CMOS	<p>Receive STS-3/STM-1 Telecom Bus - Channel 1 - Output Data Bus Pin Number 3/DS3/E3 Framer or Transmit STS-1 TOH Processor block line interface output Pin - Channel 5 (DS3/E3/STS1_DATA_OUT_5):</p> <p>The function of this output pin depends upon whether or not the STS-3/STM-1 Telecom Bus Interface, associated with Channel 1 is enabled.</p> <p>If STS-3/STM-1 Telecom Bus (Channel 1) has been enabled - STS-3/STM-1 Receive Telecom Bus - Output Data bus Pin Number 3: STSRxD_D_1_3:</p> <p>This output pin along with STS3RxD_D_1[7:4] and STS3RxD_D_1[2:0] function as the STS-3/STM-1 Receive (Drop) Telecom Bus - Output Data Bus for Channel 1. The STS-3/STM-1 Telecom Bus Interface will update the data via this output upon the rising edge of STS3RxD_CLK_1.</p> <p>If STS-3/STM-1 Telecom Bus (Channel 1) is disabled - DS3/E3/STS1_DATA_OUT Line Interface Data output Pin - Channel 5.</p> <p>This pin outputs single-rail DS3, E3 or STS-1 data to a DS3/E3/STS-1 LIU IC. This output pin should be connected to the TPOS/TDATA input of the DS3/E3/STS-1 LIU IC (corresponding to Channel 5). By default, the data that is output via this output pin will be updated upon the rising edge of the DS3/E3/STS1_CLK_OUT_5 signal pin number F25.</p> <p>For DS3/E3 Applications</p> <p>The XRT94L43 can be configured to update this output signal upon the falling edge of the DS3/E3/STS1_CLK_5 signal by setting Bit 2 (DS3/E3/STS1_CLK_OUT Invert), within the I/O Control Register - Channel 5 (Indirect Address = 0x6E, 0x01), (Direct Address = 0x6F01) to a "1".</p> <p>For STS-1 Applications</p> <p>The XRT94L43 can not be configured to update the DS3/E3/STS1_DATA_OUT_5 signal upon the falling edge of DS3/E3/STS1_CLK_OUT_5.</p>

STS-3/STM-1 TELECOM BUS INTERFACE - RECEIVE DIRECTION

PIN #	SIGNAL NAME	I/O	SIGNAL TYPE	DESCRIPTION
J26	STS3RxD_D_1_4 DS3/E3/ STS1_Data_OUT_9 RxSBDData_4	O	CMOS	<p>Receive STS-3/STM-1 Telecom Bus - Channel 1 - Output Data Bus Pin Number 4/DS3/E3 Framer or Transmit STS-1 TOH Processor block line interface output Pin - Channel 9 (DS3/E3/STS1_DATA_OUT_9):</p> <p>The function of this output pin depends upon whether or not the STS-3/STM-1 Telecom Bus Interface, associated with Channel 1 is enabled.</p> <p>If STS-3/STM-1 Telecom Bus (Channel 1) has been enabled - STS-3/STM-1 Receive Telecom Bus - Output Data bus Pin Number 4: STSRxD_D_1_4:</p> <p>This output pin along with STS3RxD_D_1[7:5] and STS3RxD_D_1[3:0] function as the STS-3/STM-1 Receive (Drop) Telecom Bus - Output Data Bus for Channel 1. The STS-3/STM-1 Telecom Bus Interface will update the data via this output upon the rising edge of STS3RxD_CLK_1.</p> <p>If STS-3/STM-1 Telecom Bus (Channel 1) is disabled - DS3/E3/STS1_DATA_OUT Line Interface Data output Pin - Channel 9.</p> <p>This pin outputs single-rail DS3, E3 or STS-1 data to a DS3/E3/STS-1 LIU IC. This output pin should be connected to the TPOS/TDATA input of the DS3/E3/STS-1 LIU IC (corresponding to Channel 9). By default, the data that is being output via this output pin will be updated upon the rising edge of the DS3/E3/STS-1_CLK_OUT_9 signal pin number H25.</p> <p>For DS3/E3 Applications</p> <p>The XRT94L43 can be configured to update the DS3/E3/STS1_DATA_9 output signal upon the falling edge of the DS3/E3/STS1_CLK_9 signal by setting Bit 2 (DS3/E3/STS1_CLK_OUT Invert), within the I/O Control Register - Channel 9 (Indirect Address = 0xAE, 0x01), (Direct Address = 0xAF01) to a "1".</p> <p>For STS-1 Applications</p> <p>The XRT94L43 can not be configured to update the DS3/E3/STS1_DATA_OUT_9 signal upon the falling edge of DS3/E3/STS1_CLK_OUT_9.</p>

STS-3/STM-1 TELECOM BUS INTERFACE - RECEIVE DIRECTION

PIN #	SIGNAL NAME	I/O	SIGNAL TYPE	DESCRIPTION
G26	STS3RxD_D_1_5 DS3/E3/STS1_CLK_OUT_1 RxSBDData_5	O	CMOS	<p>Receive STS-3/STM-1 Telecom Bus - Channel 1 - Output Data Bus Pin Number 5/DS3/E3 Framer or Transmit STS-1 TOH Processor block line interface clock output Pin - Channel 1: (DS3/E3/STS1_CLK_OUT_1):</p> <p>The function of this output pin depends upon whether or not the STS-3/STM-1 Telecom Bus Interface, associated with Channel 1 is enabled.</p> <p>If STS-3/STM-1 Telecom Bus (Channel 1) has been enabled - STS-3/STM-1 Receive Telecom Bus - Output Data bus Pin Number 5: STSRxD_D_1_5:</p> <p>This output pin along with STS3RxD_D_1[7:6] and STS3RxD_D_1[4:0] function as the STS-3/STM-1 Receive (Drop) Telecom Bus - Output Data Bus for Channel 1. The STS-3/STM-1 Telecom Bus Interface will update the data via this output upon the rising edge of STS3RxD_CLK_1.</p> <p>If STS-3/STM-1 Telecom Bus (Channel 1) is disabled - DS3/E3/STS1_CLK_OUT Line Interface Clock output Pin - Channel 1:</p> <p>This pin outputs a DS3, E3 or STS-1 rate clock signal to a DS3/E3/STS-1 LIU IC. This output pin should be connected to the TxCLK input of the DS3/E3/STS-1 LIU IC (corresponding to Channel 1).</p> <p>By default, the data, which is being output via the DS3/E3/STS1_DATA_OUT_1 output pin will be updated upon the rising edge of this clock output signal.</p> <p>For DS3/E3 Applications</p> <p>The XRT94L43 can be configured to update the DS3/E3/STS1_DATA_1 output signal upon the falling edge of the DS3/E3/STS1_CLK_1 signal by setting Bit 0 (DS3/E3/STS1_CLK_OUT Invert), within the I/O Control Register - Channel 1 (Indirect Address = 0x2E, 0x01), (Direct Address = 0x2F01) to a "1".</p> <p>For STS-1 Applications</p> <p>The XRT94L43 can not be configured to update the DS3/E3/STS1_DATA_OUT_1 signal upon the falling edge of DS3/E3/STS1_CLK_1.</p>

STS-3/STM-1 TELECOM BUS INTERFACE - RECEIVE DIRECTION

PIN #	SIGNAL NAME	I/O	SIGNAL TYPE	DESCRIPTION
F25	STS3RxD_D_1_6 DS3/E3/STS1_Clk_OUT_5 RxSBDData_6	O	CMOS	<p>Receive STS-3/STM-1 Telecom Bus - Channel 1 - Output Data Bus Pin Number 6/DS3/E3 Framer or Transmit STS-1 TOH Processor block line interface clock output Pin - Channel 5: (DS3/E3/STS1_CLK_OUT_5):</p> <p>The function of this output pin depends upon whether or not the STS-3/STM-1 Telecom Bus Interface, associated with Channel 1 is enabled.</p> <p>If STS-3/STM-1 Telecom Bus (Channel 1) has been enabled - STS-3/STM-1 Receive Telecom Bus - Output Data bus Pin Number 6: STSRxD_D_1_6:</p> <p>This output pin along with STS3RxD_D_1_7 and STS3RxD_D_1[5:0] function as the STS-3/STM-1 Receive (Drop) Telecom Bus - Output Data Bus for Channel 1. The STS-3/STM-1 Telecom Bus Interface will update the data via this output upon the rising edge of STS3RxD_CLK_1.</p> <p>If STS-3/STM-1 Telecom Bus (Channel 1) is disabled - DS3/E3/STS1_CLK_OUT Line Interface Clock output Pin - Channel 5:</p> <p>This pin outputs a DS3, E3 or STS-1 rate clock signal to a DS3/E3/STS-1 LIU IC. This output pin should be connected to the TxCLK input of the DS3/E3/STS-1 LIU IC (corresponding to Channel 5).</p> <p>By default, the data, which is being output via the DS3/E3/STS1_DATA_OUT_5 output pin will be updated upon the rising edge of this clock output signal.</p> <p>For DS3/E3 Applications</p> <p>The XRT94L43 can be configured to update the DS3/E3/STS1_DATA_5 output signal upon the falling edge of the DS3/E3/STS1_CLK_5 signal by setting Bit 0 (DS3/E3/STS1_CLK_OUT Invert), within the I/O Control Register - Channel 5 (Indirect Address = 0x6E, 0x01), (Direct Address = 0x6F01) to a "1".</p> <p>For STS-1 Applications</p> <p>The XRT94L43 can not be configured to update the DS3/E3/STS1_DATA_OUT_5 signal upon the falling edge of DS3/E3/STS1_CLK_5.</p>

STS-3/STM-1 TELECOM BUS INTERFACE - RECEIVE DIRECTION

PIN #	SIGNAL NAME	I/O	SIGNAL TYPE	DESCRIPTION
H25	STS3RxD_D_1_7 DS3/E3/STS1_Clk_OUT_9 RxSBDData_7	O	CMOS	<p>Receive STS-3/STM-1 Telecom Bus - Channel 1 - Output Data Bus Pin Number 7/DS3/E3 Framer or Transmit STS-1 TOH Processor block line interface clock output Pin - Channel 9: (DS3/E3/STS1_CLK_OUT_9):</p> <p>The function of this output pin depends upon whether or not the STS-3/STM-1 Telecom Bus Interface, associated with Channel 1 is enabled.</p> <p>If STS-3/STM-1 Telecom Bus (Channel 1) has been enabled - STS-3/STM-1 Receive Telecom Bus - Output Data bus Pin Number 7: STSRxD_D_1_7:</p> <p>This output pin along with STS3RxD_D_1[6:0] function as the STS-3/STM-1 Receive (Drop) Telecom Bus - Output Data Bus for Channel 1. The STS-3/STM-1 Telecom Bus Interface will update the data via this output upon the rising edge of STS3RxD_CLK_1.</p> <p><i>NOTE: This output pin functions as the MSB (Most Significant Bit) for the STS-3/STM-1 Receive (Drop) Telecom Bus Interface - Output Data Bus (Channel 1).</i></p> <p>If STS-3/STM-1 Telecom Bus (Channel 1) is disabled - DS3/E3/STS1_CLK_OUT Line Interface Clock output Pin - Channel 9:</p> <p>This pin outputs a DS3, E3 or STS-1 rate clock signal to a DS3/E3/STS-1 LIU IC. This output pin should be connected to the TxCLK input of the DS3/E3/STS-1 LIU IC (corresponding to Channel 9).</p> <p>By default, the data, which is being output via the DS3/E3/STS1_DATA_OUT_9 output pin will be updated upon the rising edge of this clock output pin.</p> <p>For DS3/E3 Applications</p> <p>The XRT94L43 can be configured to update the DS3/E3/STS1_DATA_9 output signal upon the falling edge of the DS3/E3/STS1_CLK_9 signal by setting Bit 0 (DS3/E3/STS1_CLK_OUT Invert), within the I/O Control Register - Channel 9 (Indirect Address = 0xAE, 0x01), (Direct Address = 0xAF01) to a "1".</p> <p>For STS-1 Applications</p> <p>The XRT94L43 can not be configured to update the DS3/E3/STS1_DATA_OUT_9 signal upon the falling edge of DS3/E3/STS1_CLK_9.</p>

STS-3/STM-1 TELECOM BUS INTERFACE - RECEIVE DIRECTION

PIN #	SIGNAL NAME	I/O	SIGNAL TYPE	DESCRIPTION
Y24	STS3RxD_D_2_0 TxLEV_2 RxSBDData_0	O	CMOS	<p>Receive STS-3/STM-1 Telecom Bus - Channel 2 - Output Data Bus Pin Number 0/TxLEV_2 (General Purpose) Output Pin:</p> <p>The function of this output pin depends upon whether or not the STS-3/STM-1 Telecom Bus Interface, associated with Channel 2 is enabled.</p> <p>If STS-3/STM-1 Telecom Bus (Channel 2) has been enabled - STS-3/STM-1 Receive Telecom Bus - Output Data bus Pin Number 0: STSRxD_D_2_0:</p> <p>This output pin along with STS3RxD_D_2[7:1] function as the STS-3/STM-1 Receive (Drop) Telecom Bus - Output Data Bus for Channel 2. The STS-3/STM-1 Telecom Bus Interface will update the data via this output upon the rising edge of STS3RxD_CLK_2.</p> <p><i>NOTE: This input pin functions as the LSB (Least Significant Bit) of the Receive (Drop) Telecom Bus for Channel 2.</i></p> <p>If STS-3/STM-1 Telecom Bus (Channel 2) is disabled - TXLEV_2 (General Purpose) output Pin:</p> <p>This output pin can be used as a general purpose output pin. The state of this output pin can be controlled by writing the appropriate value into Bit 2 (TxLEV) within the Line Interface Drive Register associated with Channel 2 (Indirect Address = 0x3E, 0x80), (Direct Address = 0x3F80).</p> <p><i>NOTE: For Product Legacy purposes, this pin is called TxLEV_2 because one possible application is to tie this output pin to a TxLEV (Transmit Line Build-Out Disable) input pin from one of Exar's XRT73L0X/ XRT75L0X DS3/E3/STS-1 LIU devices. However, this output pin, and the corresponding register bit can be used for any purpose.</i></p>

STS-3/STM-1 TELECOM BUS INTERFACE - RECEIVE DIRECTION

PIN #	SIGNAL NAME	I/O	SIGNAL TYPE	DESCRIPTION
Y23	STS3RxD_D_2_1 ENCODIS_2 RxSBData_1	O	CMOS	<p>Receive STS-3/STM-1 Telecom Bus - Channel 2 - Output Data Bus Pin Number 1/ENCODIS_2 (General Purpose) Output Pin:</p> <p>The function of this output pin depends upon whether or not the STS-3/STM-1 Telecom Bus Interface, associated with Channel 2 is enabled.</p> <p>If STS-3/STM-1 Telecom Bus (Channel 2) has been enabled - STS-3/STM-1 Receive Telecom Bus - Output Data bus Pin Number 1: STSRxD_D_2_1:</p> <p>This output pin along with STS3RxD_D_2[7:2] and STS3RxD_D_2_0 function as the STS-3/STM-1 Receive (Drop) Telecom Bus - Output Data Bus for Channel 2. The STS-3/STM-1 Telecom Bus Interface will update the data via this output upon the rising edge of STS3RxD_CLK_2.</p> <p>If STS-3/STM-1 Telecom Bus (Channel 2) is disabled - ENCODIS_2 (General Purpose) output Pin:</p> <p>This output pin can be used as a general purpose output pin. The state of this output pin can be controlled by writing the appropriate value into Bit 3 (ENCODIS) within the Line Interface Drive Register associated with Channel 2 (Indirect Address = 0x3E, 0x80), (Direct Address = 0x3F80).</p> <p>NOTE: For Product Legacy purposes, this pin is called ENCODIS_2 because one possible application is to tie this output pin to an ENCODIS (B3ZS/HDB3 Encoder Disable) input pin from one of Exar's XRT73L0X/ XRT75L0X DS3/E3/STS-1 LIU devices. However, this output pin, and the corresponding register bit can be used for any purpose.</p>

STS-3/STM-1 TELECOM BUS INTERFACE - RECEIVE DIRECTION

PIN #	SIGNAL NAME	I/O	SIGNAL TYPE	DESCRIPTION
W24	STS3RxD_D_2_2 DS3/E3/ STS1_Data_OUT_2 RxSBDData_2	O	CMOS	<p>Receive STS-3/STM-1 Telecom Bus - Channel 2 - Output Data Bus Pin Number 2/DS3/E3 Framer or Transmit STS-1 TOH Processor block line interface output Pin - Channel 1 (DS3/E3/STS1_DATA_OUT_2):</p> <p>The function of this output pin depends upon whether or not the STS-3/STM-1 Telecom Bus Interface, associated with Channel 2 is enabled.</p> <p>If STS-3/STM-1 Telecom Bus (Channel 2) has been enabled - STS-3/STM-1 Receive Telecom Bus - Output Data bus Pin Number 2: STSRxD_D_2_2:</p> <p>This output pin along with STS3RxD_D_2[7:3] and STS3RxD_D_2[1:0] function as the STS-3/STM-1 Receive (Drop) Telecom Bus - Output Data Bus for Channel 2. The STS-3/STM-1 Telecom Bus Interface will update the data via this output upon the rising edge of STS3RxD_CLK_2.</p> <p>If STS-3/STM-1 Telecom Bus (Channel 2) is disabled - DS3/E3/STS1_DATA_OUT Line Interface Data output Pin - Channel 2.</p> <p>This pin outputs single-rail DS3, E3 or STS-1 data to a DS3/E3/STS-1 LIU IC. This output pin should be connected to the TPOS/TDATA input of the DS3/E3/STS-1 LIU IC (corresponding to Channel 2). By default, the data that is output via this output pin will be updated upon the rising edge of the DS3/E3/STS1_CLK_OUT_2 signal pin number AC25.</p> <p>For DS3/E3 Applications</p> <p>For DS3/E3 Applications the XRT94L43 can be configured to update this output signal upon the falling edge of the DS3/E3/STS1_CLK_2 signal by setting Bit 2 (DS3/E3/STS1_CLK_OUT Invert), within the I/O Control Register - Channel 2 (Indirect Address = 0x3E, 0x01), (Direct Address = 0x3F01) to a "1".</p> <p>For STS-1 Applications</p> <p>The XRT94L43 can not be configured to update the DS3/E3/STS1_DATA_OUT_2 signal upon the falling edge of DS3/E3/STS1_CLK_OUT_2.</p>

STS-3/STM-1 TELECOM BUS INTERFACE - RECEIVE DIRECTION

PIN #	SIGNAL NAME	I/O	SIGNAL TYPE	DESCRIPTION
AC24	STS3RxD_D_2_3 DS3/E3/ STS1_Data_OUT_6 RxSBDData_3	O	CMOS	<p>Receive STS-3/STM-1 Telecom Bus - Channel 2 - Output Data Bus Pin Number 3/DS3/E3 Framer or Transmit STS-1 TOH Processor block line interface output Pin - Channel 6 (DS3/E3/STS1_DATA_OUT_6):</p> <p>The function of this output pin depends upon whether or not the STS-3/STM-1 Telecom Bus Interface, associated with Channel 2 is enabled.</p> <p>If STS-3/STM-1 Telecom Bus (Channel 2) has been enabled - STS-3/STM-1 Receive Telecom Bus - Output Data bus Pin Number 3: STSRxD_D_2_3:</p> <p>This output pin along with STS3RxD_D_2[7:4] and STS3RxD_D_2[2:0] function as the STS-3/STM-1 Receive (Drop) Telecom Bus - Output Data Bus for Channel 2. The STS-3/STM-1 Telecom Bus Interface will update the data via this output upon the rising edge of STS3RxD_CLK_2.</p> <p>If STS-3/STM-1 Telecom Bus (Channel 2) is disabled - DS3/E3/STS1_DATA_OUT Line Interface Data output Pin - Channel 6.</p> <p>This pin outputs single-rail DS3, E3 or STS-1 data to a DS3/E3/STS-1 LIU IC. This output pin should be connected to the TPOS/TDATA input of the DS3/E3/STS-1 LIU IC (corresponding to Channel 6). By default, the data that is output via this pin will be updated upon the rising edge of the DS3/E3/STS1_CLK_OUT_6 signal pin number AA22.</p> <p>For DS3/E3 Applications</p> <p>The XRT94L43 can be configured to update this output signal upon the falling edge of the DS3/E3/STS1_CLK_6 signal by setting Bit 2 (DS3/E3/STS1_CLK_OUT Invert), within the I/O Control Register - Channel 6 (Indirect Address = 0x7E, 0x01), (Direct Address = 0x7F01) to a "1".</p> <p>For STS-1 Applications</p> <p>The XRT94L43 can not be configured to update the DS3/E3/STS1_DATA_OUT_6 signal upon the falling edge of DS3/E3/STS1_CLK_OUT_6.</p>

STS-3/STM-1 TELECOM BUS INTERFACE - RECEIVE DIRECTION

PIN #	SIGNAL NAME	I/O	SIGNAL TYPE	DESCRIPTION
AC21	STS3RxD_D_2_4 DS3/E3/ STS1_Clk_OUT_10 RxSBDData_4	O	CMOS	<p>Receive STS-3/STM-1 Telecom Bus - Channel 2 - Output Data Bus Pin Number 4/DS3/E3 Framer or Transmit STS-1 TOH Processor block line interface output Pin - Channel 10 (DS3/E3/STS1_DATA_OUT_10):</p> <p>The function of this output pin depends upon whether or not the STS-3/STM-1 Telecom Bus Interface, associated with Channel 2 is enabled.</p> <p>If STS-3/STM-1 Telecom Bus (Channel 2) has been enabled - STS-3/STM-1 Receive Telecom Bus - Output Data bus Pin Number 4: STSRxD_D_2_4:</p> <p>This output pin along with STS3RxD_D_2[7:5] and STS3RxD_D_2[3:0] function as the STS-3/STM-1 Receive (Drop) Telecom Bus - Output Data Bus for Channel 2. The STS-3/STM-1 Telecom Bus Interface will update the data via this output upon the rising edge of STS3RxD_CLK_2.</p> <p>If STS-3/STM-1 Telecom Bus (Channel 2) is disabled - DS3/E3/STS1_DATA_OUT Line Interface Data output Pin - Channel 10.</p> <p>This pin outputs single-rail DS3, E3 or STS-1 data to a DS3/E3/STS-1 LIU IC. This output pin should be connected to the TPOS/TDATA input of the DS3/E3/STS-1 LIU IC (corresponding to Channel 10). By default, the data that is being output via the DS3/E3/STS1_DATA_OUT_10 output pin will be updated upon the rising edge of this output clock signal.</p> <p>For DS3/E3 Applications</p> <p>The XRT94L43 can be configured to update the DS3/E3/STS1_DATA_10 output signal upon the falling edge of the DS3/E3/STS1_CLK_10 signal by setting Bit 2 (DS3/E3/STS1_CLK_OUT Invert), within the I/O Control Register - Channel 10 (Indirect Address = 0xBE, 0x01), (Direct Address = 0xBF01) to a "1".</p> <p>For STS-1 Applications</p> <p>The XRT94L43 can not be configured to update the DS3/E3/STS1_DATA_OUT_10 signal upon the falling edge of DS3/E3/STS1_CLK_OUT_10.</p>

STS-3/STM-1 TELECOM BUS INTERFACE - RECEIVE DIRECTION

PIN #	SIGNAL NAME	I/O	SIGNAL TYPE	DESCRIPTION
AC25	STS3RxD_D_2_5 DS3/E3/STS1_Clk_OUT_2 RxSBDData_5	O	CMOS	<p>Receive STS-3/STM-1 Telecom Bus - Channel 2 - Output Data Bus Pin Number 5/DS3/E3 Framer or Transmit STS-1 TOH Processor block line interface clock output Pin - Channel 2: (DS3/E3/STS1_CLK_OUT_2):</p> <p>The function of this output pin depends upon whether or not the STS-3/STM-1 Telecom Bus Interface, associated with Channel 2 is enabled.</p> <p>If STS-3/STM-1 Telecom Bus (Channel 2) has been enabled - STS-3/STM-1 Receive Telecom Bus - Output Data bus Pin Number 5: STSRxD_D_2_5:</p> <p>This output pin along with STS3RxD_D_2[7:6] and STS3RxD_D_2[4:0] function as the STS-3/STM-1 Receive (Drop) Telecom Bus - Output Data Bus for Channel 2. The STS-3/STM-1 Telecom Bus Interface will update the data via this output upon the rising edge of STS3RxD_CLK_2.</p> <p>If STS-3/STM-1 Telecom Bus (Channel 2) is disabled - DS3/E3/STS1_CLK_OUT Line Interface Clock output Pin - Channel 2:</p> <p>This pin outputs a DS3, E3 or STS-1 rate clock signal to a DS3/E3/STS-1 LIU IC. This output pin should be connected to the TxCLK input of the DS3/E3/STS-1 LIU IC (corresponding to Channel 2).</p> <p>By default, the data, which is being output via the DS3/E3/STS1_DATA_OUT_2 output pin will be updated upon the rising edge of this output clock signal.</p> <p>For DS3/E3 Applications</p> <p>The XRT94L43 can be configured to update the DS3/E3/STS1_DATA_2 output signal upon the falling edge of the DS3/E3/STS1_CLK_2 signal by setting Bit 0 (DS3/E3/STS1_CLK_OUT Invert), within the I/O Control Register - Channel 2 (Indirect Address = 0x3E, 0x01), (Direct Address = 0x3F01) to a "1".</p> <p>For STS-1 Applications</p> <p>The XRT94L43 can not be configured to update the DS3/E3/STS1_DATA_OUT_2 signal upon the falling edge of DS3/E3/STS1_CLK_2.</p>

STS-3/STM-1 TELECOM BUS INTERFACE - RECEIVE DIRECTION

PIN #	SIGNAL NAME	I/O	SIGNAL TYPE	DESCRIPTION
AA22	STS3RxD_D_2_6 DS3/E3/STS1_Clk_OUT_6 RxSBDData_6	O	CMOS	<p>Receive STS-3/STM-1 Telecom Bus - Channel 2 - Output Data Bus Pin Number 6/DS3/E3 Framer or Transmit STS-1 TOH Processor block line interface clock output Pin - Channel 6: (DS3/E3/STS1_CLK_OUT_6):</p> <p>The function of this output pin depends upon whether or not the STS-3/STM-1 Telecom Bus Interface, associated with Channel 2 is enabled.</p> <p>If STS-3/STM-1 Telecom Bus (Channel 2) has been enabled - STS-3/STM-1 Receive Telecom Bus - Output Data bus Pin Number 6: STSRxD_D_2_6:</p> <p>This output pin along with STS3RxD_D_2_7 and STS3RxD_D_2[5:0] function as the STS-3/STM-1 Receive (Drop) Telecom Bus - Output Data Bus for Channel 2. The STS-3/STM-1 Telecom Bus Interface will update the data via this output upon the rising edge of STS3RxD_CLK_2.</p> <p>If STS-3/STM-1 Telecom Bus (Channel 2) is disabled - DS3/E3/STS1_CLK_OUT Line Interface Clock output Pin - Channel 6:</p> <p>This pin outputs a DS3, E3 or STS-1 rate clock signal to a DS3/E3/STS-1 LIU IC. This output pin should be connected to the TxCLK input of the DS3/E3/STS-1 LIU IC (corresponding to Channel 6).</p> <p>By default, the data, which is being output via the DS3/E3/STS1_DATA_OUT_6 output pin will be updated upon the rising edge of this output clock signal.</p> <p>For DS3/E3 Applications</p> <p>The XRT94L43 can be configured to update the DS3/E3/STS1_DATA_6 output signal upon the falling edge of the DS3/E3/STS1_CLK_6 signal by setting Bit 0 (DS3/E3/STS1_CLK_OUT Invert), within the I/O Control Register - Channel 6 (Indirect Address = 0x7E, 0x01), (Direct Address = 0x7F01) to a "1".</p> <p>For STS-1 Applications</p> <p>The XRT94L43 can not be configured to update the DS3/E3/STS1_DATA_OUT_6 signal upon the falling edge of DS3/E3/STS1_CLK_6.</p>

STS-3/STM-1 TELECOM BUS INTERFACE - RECEIVE DIRECTION

PIN #	SIGNAL NAME	I/O	SIGNAL TYPE	DESCRIPTION
AE23	STS3RxD_D_2_7 DS3/E3/ STS1_Clk_OUT_10 RxSBDData_7	O	CMOS	<p>Receive STS-3/STM-1 Telecom Bus - Channel 2 - Output Data Bus Pin Number 7/DS3/E3 Framer or Transmit STS-1 TOH Processor block line interface clock output Pin - Channel 10: (DS3/E3/STS1_CLK_OUT_10):</p> <p>The function of this output pin depends upon whether or not the STS-3/STM-1 Telecom Bus Interface, associated with Channel 2 is enabled.</p> <p>If STS-3/STM-1 Telecom Bus (Channel 2) has been enabled - STS-3/STM-1 Receive Telecom Bus - Output Data bus Pin Number 7: STSRxD_D_2_7:</p> <p>This output pin along with STS3RxD_D_2[6:0] function as the STS-3/STM-1 Receive (Drop) Telecom Bus - Output Data Bus for Channel 2. The STS-3/STM-1 Telecom Bus Interface will update the data via this output upon the rising edge of STS3RxD_CLK_2.</p> <p><i>NOTE: This output pin functions as the MSB (Most Significant Bit) for the STS-3/STM-1 Receive (Drop) Telecom Bus Interface - Output Data Bus (Channel 2).</i></p> <p>If STS-3/STM-1 Telecom Bus (Channel 2) is disabled - DS3/E3/STS1_CLK_OUT Line Interface Clock output Pin - Channel 10:</p> <p>This pin outputs a DS3, E3 or STS-1 rate clock signal to a DS3/E3/STS-1 LIU IC. This output pin should be connected to the TxCLK input of the DS3/E3/STS-1 LIU IC (corresponding to Channel 10).</p> <p>By default, the data, which is being output via the DS3/E3/STS1_DATA_OUT_10 output pin will be updated upon the rising edge of this output clock signal.</p> <p>For DS3/E3 Applications</p> <p>The XRT94L43 can be configured to update the DS3/E3/STS1_DATA_10 output signal upon the falling edge of the DS3/E3/STS1_CLK_10 signal by setting Bit 0 (DS3/E3/STS1_CLK_OUT Invert), within the I/O Control Register - Channel 10 (Indirect Address = 0xBE, 0x01), (Direct Address = 0xBF01) to a "1".</p> <p>For STS-1 Applications</p> <p>The XRT94L43 can not be configured to update the DS3/E3/STS1_DATA_OUT_10 signal upon the falling edge of DS3/E3/STS1_CLK_10.</p>

STS-3/STM-1 TELECOM BUS INTERFACE - RECEIVE DIRECTION

PIN #	SIGNAL NAME	I/O	SIGNAL TYPE	DESCRIPTION
AE21	STS3RxD_D_3_0 TxLEV_3 RxSBDData_0	O	CMOS	<p>Receive STS-3/STM-1 Telecom Bus - Channel 3 - Output Data Bus Pin Number 0/TxLEV_3 (General Purpose) Output Pin:</p> <p>The function of this output pin depends upon whether or not the STS-3/STM-1 Telecom Bus Interface, associated with Channel 3 is enabled.</p> <p>If STS-3/STM-1 Telecom Bus (Channel 3) has been enabled - STS-3/STM-1 Receive Telecom Bus - Output Data bus Pin Number 0: STSRxD_D_3_0:</p> <p>This output pin along with STS3RxD_D_3[7:1] function as the STS-3/STM-1 Receive (Drop) Telecom Bus - Output Data Bus for Channel 3. The STS-3/STM-1 Telecom Bus Interface will update the data via this output upon the rising edge of STS3RxD_CLK_3.</p> <p><i>NOTE: This input pin functions as the LSB (Least Significant Bit) of the Receive (Drop) Telecom Bus for Channel 3.</i></p> <p>If STS-3/STM-1 Telecom Bus (Channel 3) is disabled - TXLEV_3 (General Purpose) output Pin:</p> <p>This output pin can be used as a general purpose output pin. The state of this output pin can be controlled by writing the appropriate value into Bit 2 (TxLEV) within the Line Interface Drive Register associated with Channel 3 (Indirect Address = 0x4E, 0x80), (Direct Address = 0x4F80).</p> <p><i>NOTE: For Product Legacy purposes, this pin is called TxLEV_3 because one possible application is to tie this output pin to a TxLEV (Transmit Line Build-Out Disable) input pin from one of Exar's XRT73L0X/ XRT75L0X DS3/E3/STS-1 LIU devices. However, this output pin, and the corresponding register bit can be used for any purpose.</i></p>

STS-3/STM-1 TELECOM BUS INTERFACE - RECEIVE DIRECTION

PIN #	SIGNAL NAME	I/O	SIGNAL TYPE	DESCRIPTION
AC19	STS3RxD_D_3_1 ENCODIS_3 RxSBData_1	O	CMOS	<p>Receive STS-3/STM-1 Telecom Bus - Channel 3 - Output Data Bus Pin Number 1/ENCODIS_3 (General Purpose) Output Pin:</p> <p>The function of this output pin depends upon whether or not the STS-3/STM-1 Telecom Bus Interface, associated with Channel 3 is enabled.</p> <p>If STS-3/STM-1 Telecom Bus (Channel 3) has been enabled - STS-3/STM-1 Receive Telecom Bus - Output Data bus Pin Number 1: STSRxD_D_3_1:</p> <p>This output pin along with STS3RxD_D_3[7:2] and STS3RxD_D_3_0 function as the STS-3/STM-1 Receive (Drop) Telecom Bus - Output Data Bus for Channel 3. The STS-3/STM-1 Telecom Bus Interface will update the data via this output upon the rising edge of STS3RxD_CLK_3.</p> <p>If STS-3/STM-1 Telecom Bus (Channel 3) is disabled - ENCODIS_3 (General Purpose) output Pin:</p> <p>This output pin can be used as a general purpose output pin. The state of this output pin can be controlled by writing the appropriate value into Bit 3 (ENCODIS) within the Line Interface Drive Register associated with Channel 3 (Indirect Address = 0x4E, 0x80), (Direct Address = 0x4F80).</p> <p>NOTE: For Product Legacy purposes, this pin is called ENCODIS_3 because one possible application is to tie this output pin to an ENCODIS (B3ZS/HDB3 Encoder Disable) input pin from one of Exar's XRT73L0X/ XRT75L0X DS3/E3/STS-1 LIU devices. However, this output pin, and the corresponding register bit can be used for any purpose.</p>

STS-3/STM-1 TELECOM BUS INTERFACE - RECEIVE DIRECTION

PIN #	SIGNAL NAME	I/O	SIGNAL TYPE	DESCRIPTION
AB21	STS3RxD_D_3_2 DS3/E3/ STS1_Data_OUT_3 RxSBDData_2	O	CMOS	<p>Receive STS-3/STM-1 Telecom Bus - Channel 3 - Output Data Bus Pin Number 2/DS3/E3 Framer or Transmit STS-1 TOH Processor block line interface output Pin - Channel 3 (DS3/E3/STS1_DATA_OUT_3):</p> <p>The function of this output pin depends upon whether or not the STS-3/STM-1 Telecom Bus Interface, associated with Channel 3 is enabled.</p> <p>If STS-3/STM-1 Telecom Bus (Channel 3) has been enabled - STS-3/STM-1 Receive Telecom Bus - Output Data bus Pin Number 2: STSRxD_D_3_2:</p> <p>This output pin along with STS3RxD_D_3[7:3] and STS3RxD_D_3[1:0] function as the STS-3/STM-1 Receive (Drop) Telecom Bus - Output Data Bus for Channel 3. The STS-3/STM-1 Telecom Bus Interface will update the data via this output upon the rising edge of STS3RxD_CLK_3.</p> <p>If STS-3/STM-1 Telecom Bus (Channel 3) is disabled - DS3/E3/STS1_DATA_OUT Line Interface Data output Pin - Channel 3.</p> <p>This pin outputs single-rail DS3, E3 or STS-1 data to a DS3/E3/STS-1 LIU IC. This output pin should be connected to the TPOS/TDATA input of the DS3/E3/STS-1 LIU IC (corresponding to Channel 3). By default, the data that is output via this pin will be updated upon the rising edge of the DS3/E3/STS1_CLK_OUT_3 signal pin number AB20.</p> <p>For DS3/E3 Applications</p> <p>The XRT94L43 can be configured to update this output signal upon the falling edge of the DS3/E3/STS1_CLK_3 signal by setting Bit 2 (DS3/E3/STS1_CLK_OUT Invert), within the I/O Control Register - Channel 3 (Indirect Address = 0x4E, 0x01), (Direct Address = 0x4F01) to a "1".</p> <p>For STS-1 Applications</p> <p>The XRT94L43 can not be configured to update the DS3/E3/STS1_DATA_OUT_3 signal upon the falling edge of DS3/E3/STS1_CLK_OUT_3.</p>

STS-3/STM-1 TELECOM BUS INTERFACE - RECEIVE DIRECTION

PIN #	SIGNAL NAME	I/O	SIGNAL TYPE	DESCRIPTION
AE18	STS3RxD_D_3_3 DS3/E3/ STS1_Data_OUT_7 RxSBDData_3	O	CMOS	<p>Receive STS-3/STM-1 Telecom Bus - Channel 3 - Output Data Bus Pin Number 3/DS3/E3 Framer or Transmit STS-1 TOH Processor block line interface output Pin - Channel 7 (DS3/E3/STS1_DATA_OUT_7):</p> <p>The function of this output pin depends upon whether or not the STS-3/STM-1 Telecom Bus Interface, associated with Channel 3 is enabled.</p> <p>If STS-3/STM-1 Telecom Bus (Channel 3) has been enabled - STS-3/STM-1 Receive Telecom Bus - Output Data bus Pin Number 3: STSRxD_D_3_3:</p> <p>This output pin along with STS3RxD_D_3[7:4] and STS3RxD_D_3[2:0] function as the STS-3/STM-1 Receive (Drop) Telecom Bus - Output Data Bus for Channel 3. The STS-3/STM-1 Telecom Bus Interface will update the data via this output upon the rising edge of STS3RxD_CLK_3.</p> <p>If STS-3/STM-1 Telecom Bus (Channel 3) is disabled - DS3/E3/STS1_DATA_OUT Line Interface Data output Pin - Channel 6.</p> <p>This pin outputs single-rail DS3, E3 or STS-1 data to a DS3/E3/STS-1 LIU IC. This output pin should be connected to the TPOS/TDATA input of the DS3/E3/STS-1 LIU IC (corresponding to Channel 7). By default, the data that is output via this pin will be updated upon the rising edge of the DS3/E3/STS1_CLK_OUT_7 signal pin number AD19.</p> <p>For DS3/E3 Applications</p> <p>The XRT94L43 can be configured to update this output signal upon the falling edge of the DS3/E3/STS1_CLK_7 signal by setting Bit 2 (DS3/E3/STS1_CLK_OUT Invert), within the I/O Control Register - Channel 7 (Indirect Address = 0x8E, 0x01), (Direct Address = 0x8F01) to a "1".</p> <p>For STS-1 Applications</p> <p>The XRT94L43 can not be configured to update the DS3/E3/STS1_DATA_OUT_7 signal upon the falling edge of DS3/E3/STS1_CLK_OUT_7.</p>

STS-3/STM-1 TELECOM BUS INTERFACE - RECEIVE DIRECTION

PIN #	SIGNAL NAME	I/O	SIGNAL TYPE	DESCRIPTION
AE15	STS3RxD_D_3_4 DS3/E3/ STS1_Data_OUT_11 RxSBDData_4	O	CMOS	<p>Receive STS-3/STM-1 Telecom Bus - Channel 3 - Output Data Bus Pin Number 4/DS3/E3 Framer or Transmit STS-1 TOH Processor block line interface output Pin - Channel 11 (DS3/E3/STS1_DATA_OUT_11):</p> <p>The function of this output pin depends upon whether or not the STS-3/STM-1 Telecom Bus Interface, associated with Channel 3 is enabled.</p> <p>If STS-3/STM-1 Telecom Bus (Channel 3) has been enabled - STS-3/STM-1 Receive Telecom Bus - Output Data bus Pin Number 4: STSRxD_D_3_4:</p> <p>This output pin along with STS3RxD_D_3[7:5] and STS3RxD_D_3[3:0] function as the STS-3/STM-1 Receive (Drop) Telecom Bus - Output Data Bus for Channel 3. The STS-3/STM-1 Telecom Bus Interface will update the data via this output upon the rising edge of STS3RxD_CLK_3.</p> <p>If STS-3/STM-1 Telecom Bus (Channel 3) is disabled - DS3/E3/STS1_DATA_OUT Line Interface Data output Pin - Channel 1.</p> <p>This pin outputs single-rail DS3, E3 or STS-1 data to a DS3/E3/STS-1 LIU IC. This output pin should be connected to the TPOS/TDATA input of the DS3/E3/STS-1 LIU IC (corresponding to Channel 11). By default, the data that is being output via this output pin will be updated upon the rising edge of the DS3/E3/STS-1_CLK_OUT_11 signal pin number AB15.</p> <p>For DS3/E3 Applications</p> <p>The XRT94L43 can be configured to update the DS3/E3/STS1_DATA_11 output signal upon the falling edge of the DS3/E3/STS1_CLK_11 signal by setting Bit 2 (DS3/E3/STS1_CLK_OUT Invert), within the I/O Control Register - Channel 11 (Indirect Address = 0xCE, 0x01), (Direct Address = 0xCF01) to a "1".</p> <p>For STS-1 Applications</p> <p>The XRT94L43 can not be configured to update the DS3/E3/STS1_DATA_OUT_11 signal upon the falling edge of DS3/E3/STS1_CLK_OUT_11.</p>

STS-3/STM-1 TELECOM BUS INTERFACE - RECEIVE DIRECTION

PIN #	SIGNAL NAME	I/O	SIGNAL TYPE	DESCRIPTION
AB20	STS3RxD_D_3_5 DS3/E3/STS1_Clk_OUT_3 RxSBDData_5	O	CMOS	<p>Receive STS-3/STM-1 Telecom Bus - Channel 3 - Output Data Bus Pin Number 5/DS3/E3 Framer or Transmit STS-1 TOH Processor block line interface clock output Pin - Channel 3: (DS3/E3/STS1_CLK_OUT_3):</p> <p>The function of this output pin depends upon whether or not the STS-3/STM-1 Telecom Bus Interface, associated with Channel 3 is enabled.</p> <p>If STS-3/STM-1 Telecom Bus (Channel 3) has been enabled - STS-3/STM-1 Receive Telecom Bus - Output Data bus Pin Number 5: STSRxD_D_3_5:</p> <p>This output pin along with STS3RxD_D_3[7:6] and STS3RxD_D_3[4:0] function as the STS-3/STM-1 Receive (Drop) Telecom Bus - Output Data Bus for Channel 3. The STS-3/STM-1 Telecom Bus Interface will update the data via this output upon the rising edge of STS3RxD_CLK_3.</p> <p>If STS-3/STM-1 Telecom Bus (Channel 3) is disabled - DS3/E3/STS1_CLK_OUT Line Interface Clock output Pin - Channel 3:</p> <p>This pin outputs a DS3, E3 or STS-1 rate clock signal to a DS3/E3/STS-1 LIU IC. This output pin should be connected to the TxCLK input of the DS3/E3/STS-1 LIU IC (corresponding to Channel 3).</p> <p>By default, the data, which is being output via the DS3/E3/STS1_DATA_OUT_3 output pin will be updated upon the rising edge of this output pin.</p> <p>For DS3/E3 Applications</p> <p>The XRT94L43 can be configured to update the DS3/E3/STS1_DATA_3 output signal upon the falling edge of the DS3/E3/STS1_CLK_3 signal by setting Bit 0 (DS3/E3/STS1_CLK_OUT Invert), within the I/O Control Register - Channel 3 (Indirect Address = 0x4E, 0x01), (Direct Address = 0x4F01) to a "1".</p> <p>For STS-1 Applications</p> <p>The XRT94L43 can not be configured to update the DS3/E3/STS1_DATA_OUT_3 signal upon the falling edge of DS3/E3/STS1_CLK_3.</p>

STS-3/STM-1 TELECOM BUS INTERFACE - RECEIVE DIRECTION

PIN #	SIGNAL NAME	I/O	SIGNAL TYPE	DESCRIPTION
AD19	STS3RxD_D_3_6 DS3/E3/STS1_Clk_OUT_7 RxSBDData_6	O	CMOS	<p>Receive STS-3/STM-1 Telecom Bus - Channel 3 - Output Data Bus Pin Number 6/DS3/E3 Framer or Transmit STS-1 TOH Processor block line interface clock output Pin - Channel 7: (DS3/E3/STS1_CLK_OUT_7):</p> <p>The function of this output pin depends upon whether or not the STS-3/STM-1 Telecom Bus Interface, associated with Channel 3 is enabled.</p> <p>If STS-3/STM-1 Telecom Bus (Channel 3) has been enabled - STS-3/STM-1 Receive Telecom Bus - Output Data bus Pin Number 6: STSRxD_D_3_6:</p> <p>This output pin along with STS3RxD_D_3_7 and STS3RxD_D_3[5:0] function as the STS-3/STM-1 Receive (Drop) Telecom Bus - Output Data Bus for Channel 3. The STS-3/STM-1 Telecom Bus Interface will update the data via this output upon the rising edge of STS3RxD_CLK_3.</p> <p>If STS-3/STM-1 Telecom Bus (Channel 3) is disabled - DS3/E3/STS1_CLK_OUT Line Interface Clock output Pin - Channel 7:</p> <p>This pin outputs a DS3, E3 or STS-1 rate clock signal to a DS3/E3/STS-1 LIU IC. This output pin should be connected to the TxCLK input of the DS3/E3/STS-1 LIU IC (corresponding to Channel 7).</p> <p>By default, the data, which is being output via the DS3/E3/STS1_DATA_OUT_7 output pin will be updated upon the rising edge of this output pin.</p> <p>For DS3/E3 Applications</p> <p>The XRT94L43 can be configured to update the DS3/E3/STS1_DATA_6 output signal upon the falling edge of the DS3/E3/STS1_CLK_7 signal by setting Bit 0 (DS3/E3/STS1_CLK_OUT Invert), within the I/O Control Register - Channel 7 (Indirect Address = 0x8E, 0x01), (Direct Address = 0x8F01) to a "1".</p> <p>For STS-1 Applications</p> <p>The XRT94L43 can not be configured to update the DS3/E3/STS1_DATA_OUT_7 signal upon the falling edge of DS3/E3/STS1_CLK_7.</p>

STS-3/STM-1 TELECOM BUS INTERFACE - RECEIVE DIRECTION

PIN #	SIGNAL NAME	I/O	SIGNAL TYPE	DESCRIPTION
AB15	STS3RxD_D_3_7 DS3/E3/STS1_CLK_OUT_11 RxSBDData_7	O	CMOS	<p>Receive STS-3/STM-1 Telecom Bus - Channel 3 - Output Data Bus Pin Number 7/DS3/E3 Framer or Transmit STS-1 TOH Processor block line interface clock output Pin - Channel 11: (DS3/E3/STS1_CLK_OUT_11):</p> <p>The function of this output pin depends upon whether or not the STS-3/STM-1 Telecom Bus Interface, associated with Channel 3 is enabled.</p> <p>If STS-3/STM-1 Telecom Bus (Channel 3) has been enabled - STS-3/STM-1 Receive Telecom Bus - Output Data bus Pin Number 7: STSRxD_D_3_7:</p> <p>This output pin along with STS3RxD_D_3[6:0] function as the STS-3/STM-1 Receive (Drop) Telecom Bus - Output Data Bus for Channel 3. The STS-3/STM-1 Telecom Bus Interface will update the data via this output upon the rising edge of STS3RxD_CLK_3.</p> <p><i>NOTE: This output pin functions as the MSB (Most Significant Bit) for the STS-3/STM-1 Receive (Drop) Telecom Bus Interface - Output Data Bus (Channel 3).</i></p> <p>If STS-3/STM-1 Telecom Bus (Channel 3) is disabled - DS3/E3/STS1_CLK_OUT Line Interface Clock output Pin - Channel 11:</p> <p>This pin outputs a DS3, E3 or STS-1 rate clock signal to a DS3/E3/STS-1 LIU IC. This output pin should be connected to the TxCLK input of the DS3/E3/STS-1 LIU IC (corresponding to Channel 11).</p> <p>By default, the data, which is being output via the DS3/E3/STS1_DATA_OUT_11 output pin will be updated upon the rising edge of this clock output signal.</p> <p>For DS3/E3 Applications</p> <p>The XRT94L43 can be configured to update the DS3/E3/STS1_DATA_11 output signal upon the falling edge of the DS3/E3/STS1_CLK_11 signal by setting Bit 0 (DS3/E3/STS1_CLK_OUT Invert), within the I/O Control Register - Channel 11 (Indirect Address = 0xCE, 0x01), (Direct Address = 0xCF01) to a "1".</p> <p>For STS-1 Applications</p> <p>The XRT94L43 can not be configured to update the DS3/E3/STS1_DATA_OUT_11 signal upon the falling edge of DS3/E3/STS1_CLK_11.</p>

RECEIVE TRANSPORT OVERHEAD INTERFACE

PIN #	SIGNAL NAME	I/O	SIGNAL TYPE	DESCRIPTION
Y5	RxTOHClk	O	CMOS	<p>Receive TOH Output Port - Clock Output:</p> <p>This output pin, along with RxTOH, RxTOHValid and RxTOHFrame function as the Receive TOH Output Port:</p> <p>The Receive TOH Output Port is used to obtain the value of the TOH Bytes, within the incoming STS-12/STM-4 signal.</p> <p>This output pin provides a clock signal.</p> <p>If the RxTOHValid output pin is "High", then the contents of the TOH bytes within the incoming STS-12 data-stream, will be serially output via the RxTOH output. This data will be updated upon the falling edge of this clock signal. Therefore, it is advisable to sample the data (at the RxTOH output pin) upon the rising edge of this clock output signal.</p>
W5	RxTOHValid	O	CMOS	<p>Receive TOH Output Port - TOH Valid (or READY) indicator:</p> <p>This output pin, along with RxTOH and RxTOHFrame function as the Receive TOH Output Port.</p> <p>This output pin will toggle "High" whenever valid TOH data is being output via the RxTOH output pin.</p>
V6	RxTOH	O	CMOS	<p>Receive TOH Output port - Output Pin:</p> <p>This output pin, along with RxTOHClk, RxTOHValid and RxTOHFrame function as the Receive TOH Output port.</p> <p>All TOH data, that resides within the incoming STS-12 data-stream will be output via this output pin.</p> <p>The RxTOHValid output pin will toggle "High", coincident with anytime a bit (from the Receive STS-12 TOH data) is being output via this output pin.</p> <p>The RxTOHFrame output pin will pulse "High" (for eight periods of RxTOHClk) coincident to when the A1 byte is being output via this output pin.</p> <p>Data, on this output pin, is updated upon the falling edge of RxTOHClk.</p>
W6	RxTOHFrame	O	CMOS	<p>Receive TOH Output Port - STS-12/STM-4 Frame Indicator:</p> <p>This output pin, along with the RxTOHClk, RxTOHValid and RxTOH output pins function as the Receive TOH Output port.</p> <p>This output pin will pulse "High", for one period of RxTOHClk, one RxTOHClk period prior to the very first TOH bit (of a given STS-12 frame) being output via the RxTOH output pin.</p>
W2	RxLDCCVAL	O	CMOS	<p>Receive - Line DCC Output Port - DCC Value Indicator Output Pin:</p> <p>This output pin, along with the RxTOHClk and the RxLDCC output pins function as the Receive Line DCC output port of the XRT94L43.</p> <p>This output pin pulses "High" coincident to when the Receive Line DCC output port outputs a DCC bit via the RxLDCC output pin.</p> <p>This output pin is updated upon the falling edge of RxTOHClk.</p> <p>The Line DCC HDLC Controller circuitry that is interfaced to this output pin, the RxLDCC and the RxTOHClk pins is suppose to do the following.</p> <ol style="list-style-type: none"> 1. It should continuously sample and monitor the state of this output pin upon the rising edge of RxTOHClk. 2. Anytime the Line DCC HDLC circuitry samples this output pin being "High", it should sample and latch the data on the RxLDCC output pin (as a valid Line DCC bit) into the Line DCC HDLC circuitry.

RECEIVE TRANSPORT OVERHEAD INTERFACE

PIN #	SIGNAL NAME	I/O	SIGNAL TYPE	DESCRIPTION
W3	RxLDCC	O	CMOS	<p>Receive - Line DCC Output Port - Output Pin:</p> <p>This output pin, along with RxLDCCVAL and the RxTOHCik output pins function as the Receive Line DCC output port of the XRT94L43.</p> <p>This pin outputs the contents of the Line DCC (e.g., the D4, D5, D6, D7, D8, D9, D10, D11 and D12 bytes), within the incoming STS-12 data-stream. The Receive Line DCC Output port will assert the RxLDCCVAL output pin, in order to indicate that the data, residing on the RxLDCC output pin is a valid Line DCC byte. The Receive Line DCC output port will update the RxLDCCVAL and the RxLDCC output pins upon the falling edge of the RxTOHCik output pin. The Line DCC HDLC circuitry that is interfaced to this output pin, the RxLDCCVAL and the RxTOHCik pins is suppose to do the following.</p> <ol style="list-style-type: none"> 1. It should continuously sample and monitor the state of the RxLDCCVAL output pin upon the rising edge of RxTOHCik. 2. Anytime the Line DCC HDLC circuitry samples the RxLDCCVAL output pin "High", it should sample and latch the contents of this output pin (as a valid Line DCC bit) into the Line DCC HDLC circuitry.
Y1	RxE1F1E2FP	O	CMOS	<p>Receive - Order-Wire Output Port - Frame Boundary Indicator:</p> <p>This output pin, along with RxE1F1E2, RxE1F1E2Val and the RxTOHCik output pins function as the Receive Order-Wire Output port of the XRT94L43.</p> <p>This output pin pulses "High" (for one period of RxTOHCik) coincident to when the very first bit (of the E1 byte) is being output via the RxE1F1E2 output pin.</p>
Y2	RxE1F1E2	O	CMOS	<p>Receive - Order-Wire Output Port - Output Pin:</p> <p>This output pin, along with RxE1F1E2Val, RxE1F1E2FP, and the RxTOHCik output pins function as the Receive Order-Wire Output Port of the XRT94L43.</p> <p>This pin outputs the contents of the Order-Wire bytes (e.g., the E1, F1 and E2 bytes) within the incoming STS-12 data-stream.</p> <p>The Receive Order-Wire Output port will pulse the RxE1F1E2FP output pin "High" (for one period of RxTOHCik) coincident to when the very first bit (of the E1 byte) is being output via the RxE1F1E2 output pin. Additionally, the Receive Order-Wire Output port will also assert the RxE1F1E2Val output pin, in order to indicate that the data, residing on the RxE1F1E2 output pin is a valid Order-Wire byte.</p> <p>The Receive Order-Wire output port will update the RxE1F1E2Val, the RxE1F1E2FP and the RxE1F1E2 output pins upon the falling edge of the RxTOHCik output pin.</p> <p>The Receive Order-Wire circuitry that is interfaced to this output pin, and the RxE1F1E2Val, the RxE1F1E2 and the RxTOHCik pins is suppose to do the following;</p> <ol style="list-style-type: none"> 1. It should continuously sample and monitor the state of the RxE1F1E2Val and RxE1F1E2FP output pins upon the rising edge of RxTOHCik. 2. Anytime the Order-wire circuitry samples the RxE1F1E2Val and RxE1F1E2FP output pins "High", it should begin to sample and latch the contents of this output pin (as a valid Order-Wire bit) into the Order-Wire circuitry. 3. The Order-Wire circuitry should continue to sample and latch the contents of the output pin until the RxE1F2E2Val output pin is sampled "Low".

RECEIVE TRANSPORT OVERHEAD INTERFACE

PIN #	SIGNAL NAME	I/O	SIGNAL TYPE	DESCRIPTION
AB5	RxSDCC	O	CMOS	<p>Receive - Section DCC Output Port - Output Pin:</p> <p>This output pin, along with RxSDCCVAL and the RxTOHCik output pins function as the Receive Section DCC output port of the XRT94L43.</p> <p>This pin outputs the contents of the Section DCC (e.g., the D1, D2 and D3 bytes), within the incoming STS-12 data-stream. The Receive Section DCC Output port will assert the RxSDCCVAL output pin, in order to indicate that the data, residing on the RxSDCC output pin is a valid Section DCC byte. The Receive Section DCC output port will update the RxSDCCVAL and the RxSDCC output pins upon the falling edge of the RxTOHCik output pin. The Section DCC HDLC circuitry that is interfaced to this output pin, the RxSDCCVAL and the RxTOHCik pins is suppose to do the following.</p> <ol style="list-style-type: none"> 1. It should continuously sample and monitor the state of the RxSDCCVAL output pin upon the rising edge of RxTOHCik. 2. Anytime the Section DCC HDLC circuitry samples the RxSDCCVAL output pin "High", it should sample and latch the contents of this output pin (as a valid Section DCC bit) into the Section DCC HDLC circuitry.
AA5	RxSDCCVAL	O	CMOS	<p>Receive - Section DCC Output Port - DCC Value Indicator Output Pin:</p> <p>This output pin, along with the RxTOHCik and the RxSDCC output pins function as the Receive Section DCC output port of the XRT94L43.</p> <p>This output pin pulses "High" coincident to when the Receive Section DCC output port outputs a DCC bit via the RxSDCC output pin.</p> <p>This output pin is updated upon the falling edge of RxTOHCik.</p> <p>The Section DCC HDLC Controller circuitry that is interfaced to this output pin, the RxSDCC and the RxTOHCik pins is suppose to do the following.</p> <ol style="list-style-type: none"> 1. It should continuously sample and monitor the state of this output pin upon the rising edge of RxTOHCik. 2. Anytime the Section DCC HDLC circuitry samples this output pin being "High", it should sample and latch the data on the RxSDCC output pin (as a valid Section DCC bit) into the Section DCC HDLC circuitry.
W4	RxE1F1E2VAL	O	CMOS	<p>Receive - Order Wire Output Port - E1F1E2 Value Indicator Output Pin:</p> <p>This output pin, along with the RxTOHCik, RxE1F1E2FP, RxE1F1E2 and RxTOHCik output pins function as the Receive - Order Wire Output Port of the XRT94L43.</p> <p>This output pin pulses "High" coincident to when the Receive - Order Wire output port outputs the contents of an E1, F1 or E2 byte, via the RxE1F1E2 output pin.</p> <p>This output pin is updated upon the falling edge of RxTOHCik.</p> <p>The Receive Order-Wire circuitry, that is interfaced to this output pin, the RxE1F1E2 and the RxTOHCik pins is suppose to do the following.</p> <ol style="list-style-type: none"> 1. It should continuously sample and monitor the state of this output pin upon the rising edge of RxTOHCik. 2. Anytime the Receive Order-Wire circuitry samples this output pin being "High", it should sample and latch the data on the RxE1F1E2 output pin (as a valid Order-wire bit) into the Receive Order-Wire circuitry.

RECEIVE TRANSPORT OVERHEAD INTERFACE

PIN #	SIGNAL NAME	I/O	SIGNAL TYPE	DESCRIPTION
B8 B4 AA3 AE3 C6 A1 AB3 AE4 C5 B7 AC3 AF3 A8 A3 Y3 AD3	RxPOH_0 RxPOH_1 RxPOH_2 RxPOH_3 RxPOH_4 RxPOH_5 RxPOH_6 RxPOH_7 RxPOH_8 RxPOH_9 RxPOH_10 RxPOH_11 RxPOH_12 RxPOH_13 RxPOH_14 RxPOH_15	O	CMOS	<p>Receive SONET POH Processor Block - Path Overhead Output Port - Output Pin:</p> <p>These output pins, along with the RxPOHCik_n, RxPOHFrame_n and RxPOHValid_n function as the Receive SONET POH Processor block - POH Output port.</p> <p>These pins serially output the POH data that have been received by each of the Receive SONET POH Processor blocks (via the incoming STS-12 data-stream). Each bit, within the POH bytes is updated (via these output pins) upon the falling edge of RxPOHCik_n. As a consequence, external circuitry receiving this data, should sample this data upon the rising edge of RxPOHCik_n.</p>
B9 B5 AA4 AA8 B6 C4 AB4 AE5 E7 A5 AC4 AB8 A9 D6 Y4 AD4	RxPOHCik_0 RxPOHCik_1 RxPOHCik_2 RxPOHCik_3 RxPOHCik_4 RxPOHCik_5 RxPOHCik_6 RxPOHCik_7 RxPOHCik_8 RxPOHCik_9 RxPOHCik_10 RxPOHCik_11 RxPOHCik_12 RxPOHCik_13 RxPOHCik_14 RxPOHCik_15	O	CMOS	<p>Receive SONET POH Processor Block - Path Overhead Output Port - Clock Output Signal:</p> <p>These output pins, along with RxPOH_n, RxPOHFrame_n and RxPOHValid_n function as the Receive SONET POH Processor block - POH Output Port.</p> <p>These output pins function as the Clock Output signals for the Receive SONET POH Processor block - POH Output Port. The RxPOH_n, RxPOHFrame_n and RxPOHValid_n output pins are updated upon the falling edge of this clock signal. As a consequence, the external circuitry should sample these signals upon the rising edge of this clock signal.</p>

RECEIVE TRANSPORT OVERHEAD INTERFACE

PIN #	SIGNAL NAME	I/O	SIGNAL TYPE	DESCRIPTION
B3	RxPOHFrame_0	O	CMOS	<p>Receive SONET POH Processor Block - Path Overhead Output Port - Frame Boundary Indicator:</p> <p>These output pins, along with the RxPOH_n, RxPOHClk_n and RxPOHValid_n output pins function as the Receive SONET POH Processor Block - Path Overhead Output Port.</p> <p>These output pins will pulse "High" coincident with the very first POH byte (J1), of a given STS-1 frame, is being output via the corresponding RxPOH_n output pin.</p>
C3	RxPOHFrame_1			
AB1	RxPOHFrame_2			
AF1	RxPOHFrame_3			
D4	RxPOHFrame_4			
F7	RxPOHFrame_5			
AC1	RxPOHFrame_6			
AC5	RxPOHFrame_7			
F5	RxPOHFrame_8			
C7	RxPOHFrame_9			
AD1	RxPOHFrame_10			
AD5	RxPOHFrame_11			
F8	RxPOHFrame_12			
E4	RxPOHFrame_13			
AA1	RxPOHFrame_14			
AE1	RxPOHFrame_15			

RECEIVE TRANSPORT OVERHEAD INTERFACE

PIN #	SIGNAL NAME	I/O	SIGNAL TYPE	DESCRIPTION
E6 D3 AB2 AF2 D5 A4 AC2 AC6 A2 C9 AD2 AC7 C8 E5 AA2 AE2	RxPOHValid_0 RxPOHValid_1 RxPOHValid_2 RxPOHValid_3 RxPOHValid_4 RxPOHValid_5 RxPOHValid_6 RxPOHValid_7 RxPOHValid_8 RxPOHValid_9 RxPOHValid_10 RxPOHValid_11 RxPOHValid_12 RxPOHValid_13 RxPOHValid_14 RxPOHValid_15	O	CMOS	<p>Receive SONET POH Processor Block - Path Overhead Output Port - Valid POH Data Indicator:</p> <p>These output pins, along with RxPOH_n, RxPOHClk_n and RxPOHFrame_n function as the Receive SONET POH Processor block - Path Overhead Output port.</p> <p>These output pins will toggle "High" coincident with when valid POH data is being output via the RxPOH_n output pins. This output is updated upon the falling edge of RxPOHClk_n. Hence, external circuitry should sample these signals upon rising edge of RxPOHClk_n.</p>
AA7	LOF 8kHz_OUT	O	CMOS	<p>Receive STS-12 LOF (Loss of Frame) Indicator/8kHz Clock Output:</p> <p>The function of this output pin depends upon whether or not the 8kHz Clock Generation feature has been enabled.</p> <p>8kHz Clock Generation Feature - not enabled (Normal Mode) - The STS-12 Loss of Frame Indicator Output:</p> <p>This output pin indicates whether or not the Receive STS-12 TOH Processor block (within the device) is declaring the LOF condition.</p> <p>"Low" - Indicates that the Receive STS-12 TOH Processor block is NOT currently declaring the LOF condition.</p> <p>"High" - Indicates that the Receive STS-12 TOH Processor block is currently declaring the LOF condition.</p> <p>8kHz Clock Generation Feature - Enabled - 8kHz Clock Output:</p> <p>If this feature is enabled, the XRT94L43 will be configured to derive and generate 8kHz clock output signals, from a particular STS-1 signal that is being received via one of the 12 Receive STS-1 TOH/POH Processor blocks.</p>

GENERAL PURPOSE INPUT/OUTPUT

PIN #	SIGNAL NAME	I/O	SIGNAL TYPE	DESCRIPTION
A19	GPIO_0 ExtLOS_0 SSE_CLK	I/O	TTL/ CMOS	<p>General Purpose Input/Output Pin or External LOS Input Pin/Slow-Speed Interface - Egress - Clock I/O: The function of this input pin depends on whether or not Channel 0 of the DS3/E3 Framer Block is enabled or whether or not the Slow-Speed Interface is enabled.</p> <p>GPIO_0 (DS3/E3 Framer Block - Channel 0 is disabled). If the DS3/E3 Framer Block is disabled, then this pin will function as a General Purpose Input/Output pin. This input pin can be configured to function as either an input or output pin by writing the appropriate value into Bit 0 (GPIO_DIR_0), within the Operation General Purpose Input/Output Direction Register - 0 (Indirect Address = 0x00, 0x4B), (Direct Address = 0x014B). When configured as an input pin, the state of this pin can be monitored by reading the state of Bit 0 (GPIO_0) within the Operation General Purpose Input/Output Register - Byte 0 (Indirect Address = 0x00, 047), (Direct Address = 0x0147). When configured as an output pin, the state of this pin can be controlled by writing the appropriate value into Bit 0 (GPIO_0) within the Operation General Purpose Input/Output Register - Byte 0 (Indirect Address = 0x00, 0x47), (Direct Address = 0x047).</p> <p>ExtLOS_0 (DS3/E3 Framer Block - Channel 0 is enabled). If the DS3/E3 Framer Block is enabled, then this pin will function as the External LOS Input pin for Channel 0. This input pin is intended to be connected to a LOS output pin of a DS3/E3 LIU IC. If this input pin is pulled "High", then the corresponding DS3/E3 Framer block will automatically declare an LOS condition.</p> <p>SSE_CLK (Slow-Speed Interface - Egress Port is enabled): If the Slow-Speed Interface - Egress (SSE) Port is enabled, then this pin will function as either the SSE_CLK output pin or the SSE_CLK input pin. If the user configures the SSE port to operate in the "Insert" Mode, then the SSE port will be configured to replace any "user-selected" Egress DS3/E3 or STS-1 data-stream (within the XRT94L43 device) with the data that is applied to the SSE_POS and SSE_NEG input pins. More specifically, in the Insert Mode, this pin will function as the SSE_CLK input pin. In this case, the SSE port will sample and latch the contents of the SSE_POS and SSE_NEG input pins upon the falling edge of this input clock signal. If the user configures the SSE port to operate in the "Extract" Mode, then the SSE port will output any "user-selected" Egress DS3/E3 or STS-1 signal (within the XRT94L43 device) via this output port. More specifically, in the "Extract Mode", this pin will function as the SSE_CLK output pin. In this case, the SSE port will output the data (via the SSE_POS and SSE_NEG output pins) upon the rising edge of this output clock signal.</p>

GENERAL PURPOSE INPUT/OUTPUT

PIN #	SIGNAL NAME	I/O	SIGNAL TYPE	DESCRIPTION
D22	GPIO_1 ExtLOS_1 SSI_CLK	I/O	TTL/ CMOS	<p>General Purpose Input/Output Pin or External LOS Input Pin/Slow-Speed Interface - Ingress - Clock I/O: The function of this input pin depends on whether or not Channel 1 of the DS3/E3 Framer Block is enabled, or whether or not the Slow Speed Interface is enabled.</p> <p>GPIO_1 (DS3/E3 Framer Block - Channel 1 is disabled). If the DS3/E3 Framer Block is disabled, then this pin will function as a General Purpose Input/Output pin. This input pin can be configured to function as either an input or output pin by writing the appropriate value into Bit 1 (GPIO_DIR_1), within the Operation General Purpose Input/Output Direction Register - 0 (Indirect Address = 0x00, 0x4B), (Direct Address = 0x014B). When configured as an input pin, the state of this pin can be monitored by reading the state of Bit 1 (GPIO_1) within the Operation General Purpose Input/Output Register - Byte 0 (Indirect Address = 0x00, 047). When configured as an output pin, the state of this pin can be controlled by writing the appropriate value into Bit 1 (GPIO_1) within the Operation General Purpose Input/Output Register - Byte 0 (Indirect Address = 0x00, 0x47), (Direct Address = 0x0147).</p> <p>ExtLOS_1 (DS3/E3 Framer Block - Channel 1 is enabled), Slow-Speed Interface is Disabled). If the DS3/E3 Framer Block is enabled, then this pin will function as the External LOS Input pin for Channel 1. This input pin is intended to be connected to an LOS output pin of a DS3/E3 LIU IC. If this input pin is pulled "High", then the corresponding DS3/E3 Framer block will automatically declare an LOS condition.</p> <p>SSI_CLK (Slow-Speed Interface - Ingress Port is enabled): If the Slow-Speed Interface -Ingress (SSI) Port is enabled, then this pin will function as either the SSI_CLK output pin or the SSI_CLK input pin. If the user configures the SSI port to operate in the "Insert" Mode, then the SSI port will be configured to replace any "user-selected" Ingress DS3/E3 or STS-1 data-stream (within the XRT94L43 device) with the data that is applied to the SSI_POS and SSI_NEG input pins. More specifically, in the "Insert" Mode, this pin will function as the "SSI_CLK" input pin. In this case, the SSI port will sample and latch the contents of the SSI_POS and SSI_NEG input pins upon the falling edge of this input clock signal. If the user configures the SSI port to operate in the "Extract" Mode, then the SSI port will output any "user-selected" Ingress DS3/E3 or STS-1 signal (within the XRT94L43 device) via this output port. More specifically, in the "Extract Mode", this pin will function as the SSI_CLK output pin. In this case, the SSI port will output the data (via the SSI_POS and SSI_NEG output pins) upon the rising edge of this output clock signal.</p>

GENERAL PURPOSE INPUT/OUTPUT

PIN #	SIGNAL NAME	I/O	SIGNAL TYPE	DESCRIPTION
W25	GPIO_2 ExtLOS_2 SSI_POS	I/O	TTL/ CMOS	<p>General Purpose Input/Output Pin or External LOS Input Pin/Slow-Speed Interface -Ingress - Positive Data I/O: The function of this input pin depends on whether or not Channel 2 of the DS3/E3 Framer Block is enabled..</p> <p>GPIO_2 (DS3/E3 Framer Block - Channel 2 is disabled). If the DS3/E3 Framer Block is disabled, then this pin will function as a General Purpose Input/Output pin. This input pin can be configured to function as either an input or output pin by writing the appropriate value into Bit 2 (GPIO_DIR_2), within the Operation General Purpose Input/Output Direction Register - 0 (Indirect Address = 0x00, 0x4B), (Direct Address = 0x014B).</p> <p>When configured as an input pin, the state of this pin can be monitored by reading the state of Bit 2 (GPIO_2) within the Operation General Purpose Input/Output Register - Byte 0 (Indirect Address = 0x00, 047), (Direct Address = 0x0147).</p> <p>When configured as an output pin, the state of this pin can be controlled by writing the appropriate value into Bit 2 (GPIO_2) within the Operation General Purpose Input/Output Register - Byte 0 (Indirect Address = 0x00, 0x47), (Direct Address = 0x0147).</p> <p>ExtLOS_2 (DS3/E3 Framer Block - Channel 2 is enabled, Slow-Speed Interface is Disabled). If the DS3/E3 Framer Block is enabled, then this pin will function as the External LOS Input pin for Channel 2. This input pin is intended to be connected to an LOS output pin of a DS3/E3 LIU IC. If this input pin is pulled "High", then the corresponding DS3/E3 Framer block will automatically declare an LOS condition.</p> <p>SSI_POS (Slow-Speed Interface - Ingress Port is enabled): If the Slow-Speed Interface - Ingress (SSI) Port is enabled, then this pin will function as either the SSI_POS output pin or the SSI_POS input pin. If the user configures the SSI port to operate in the "Insert" Mode, then the SSI port will be configured to replace any "user-selected" Ingress DS3/E3 or STS-1 data-stream (within the XRT94L43 device) with the data that is applied to the SSI_POS and SSI_NEG input pins. More specifically, in the "Insert" Mode, this pin will function as the SSI_POS input pin. In this case, the SSI port will sample and latch the contents of this input pin (along with SSI_NEG, in a Dual-Rail Manner) upon the falling edge of the SSI_CLK input clock signal. If the user configures the SSI port to operate in the "Extract" Mode, then the SSI port will output any "user-selected" Ingress DS3/E3 or STS-1 signal (within the XRT94L43 device) via this output port. More specifically, in the "Extract Mode", this pin will function as the SSI_POS output pin. In this case, the SSI port will output data via this pin, along with the SSI_NEG output pin (in a Dual-Rail Manner) upon the rising edge of the SSI_CLK output signal.</p>

GENERAL PURPOSE INPUT/OUTPUT

PIN #	SIGNAL NAME	I/O	SIGNAL TYPE	DESCRIPTION
AC22	GPIO_3 ExtLOS_3 SSE_NEG	I/O	TTL/ CMOS	<p>General Purpose Input/Output Pin or External LOS Input Pin/Slow-Speed Interface - Egress - Negative Data I/O: The function of this input pin depends on whether or not Channel 3 of the DS3/E3 Framer Block is enabled, or whether or not the Slow Speed Interface is enabled.</p> <p>GPIO_3 (DS3/E3 Framer Block - Channel 3 is disabled). If the DS3/E3 Framer Block is disabled, then this pin will function as a General Purpose Input/Output pin. This input pin can be configured to function as either an input or output pin by writing the appropriate value into Bit 3 (GPIO_DIR_3), within the Operation General Purpose Input/Output Direction Register - 0 (Indirect Address = 0x00, 0x4B), (Direct Address = 0x014B). When configured as an input pin, the state of this pin can be monitored by reading the state of Bit 3 (GPIO_3) within the Operation General Purpose Input/Output Register - Byte 0 (Indirect Address = 0x00, 047), (Direct Address = 0x0147). When configured as an output pin, the state of this pin can be controlled by writing the appropriate value into Bit 3 (GPIO_3) within the Operation General Purpose Input/Output Register - Byte 0 (Indirect Address = 0x00, 0x47), (Direct Address = 0x0147).</p> <p>ExtLOS_3 (DS3/E3 Framer Block - Channel 3 is enabled, Slow-Speed Interface is Disabled). If the DS3/E3 Framer Block is enabled, then this pin will function as the External LOS Input pin for Channel 3. This input pin is intended to be connected to an LOS output pin of a DS3/E3 LIU IC. If this input pin is pulled "High", then the corresponding DS3/E3 Framer block will automatically declare an LOS condition.</p> <p>SSE_NEG (Slow-Speed Interface - Egress Port is enabled): If the Slow-Speed Interface - Egress (SSE) Port is enabled, then this pin will function as either the SSE_NEG output pin or the SSE_NEG input pin. If the user configures the SSE port to operate in the "Insert" Mode, then the SSE port will be configured to replace any "user-selected" Egress DS3/E3 or STS-1 data-stream (within the XRT94L43 device) with the data that is applied to the SSE_POS and SSE_NEG input pins. More specifically, in the "Insert" Mode, this pin will function as the SSE_NEG input pin. In this case, the SSE port will sample and latch the contents of this input pin (along with SSE_POS, in a Dual-Rail Manner) upon the falling edge of the SSE_CLK input clock signal. If the user configures the SSE port to operate in the "Extract" Mode, then the SSE port will output any "user-selected" Egress DS3/E3 or STS-1 signal (within the XRT94L43 device) via this output port. More specifically, in the "Extract Mode" this pin will function as the SSE_NEG output pin. In this case, the SSE port will output data via this pin, along with the SSE_POS output pin (in a Dual-Rail Manner) upon the rising edge of the SSE_CLK output signal.</p>

GENERAL PURPOSE INPUT/OUTPUT

PIN #	SIGNAL NAME	I/O	SIGNAL TYPE	DESCRIPTION
A23	GPIO_4 ExtLOS_4	I/O	TTL/ CMOS	<p>General Purpose Input/Output Pin or External LOS Input Pin: The function of this input pin depends on whether or not Channel 4 of the DS3/E3 Framer Block is enabled.</p> <p>GPIO_4 (DS3/E3 Framer Block - Channel 4 is disabled). If the DS3/E3 Framer Block is disabled, then this pin will function as a General Purpose Input/Output pin. This input pin can be configured to function as either an input or output pin by writing the appropriate value into Bit 4 (GPIO_DIR_4), within the Operation General Purpose Input/Output Direction Register - 0 (Indirect Address = 0x00, 0x4B), (Direct Address = 0x014B).</p> <p>When configured as an input pin, the state of this pin can be monitored by reading the state of Bit 4 (GPIO_4) within the Operation General Purpose Input/Output Register - Byte 0 (Indirect Address = 0x00, 047), (Direct Address = 0x0147).</p> <p>When configured as an output pin, the state of this pin can be controlled by writing the appropriate value into Bit 4 (GPIO_4) within the Operation General Purpose Input/Output Register - Byte 0 (Indirect Address = 0x00, 0x47), (Direct Address = 0x0147).</p> <p>ExtLOS_4 (DS3/E3 Framer Block - Channel 4 is enabled). If the DS3/E3 Framer Block is enabled, then this pin will function as the External LOS Input pin for Channel 4. This input pin is intended to be connected to an LOS output pin of a DS3/E3 LIU IC. If this input pin is pulled "High", then the corresponding DS3/E3 Framer block will automatically declare an LOS condition.</p>
F24	GPIO_5 ExtLOS_5	I/O	TTL/ CMOS	<p>General Purpose Input/Output Pin or External LOS Input Pin: The function of this input pin depends on whether or not Channel 5 of the DS3/E3 Framer Block is enabled.</p> <p>GPIO_5 (DS3/E3 Framer Block - Channel 5 is disabled). If the DS3/E3 Framer Block is disabled, then this pin will function as a General Purpose Input/Output pin. This input pin can be configured to function as either an input or output pin by writing the appropriate value into Bit 5 (GPIO_DIR_5), within the Operation General Purpose Input/Output Direction Register - 0 (Indirect Address = 0x00, 0x4B), (Direct Address = 0x014B).</p> <p>When configured as an input pin, the state of this pin can be monitored by reading the state of Bit 5 (GPIO_5) within the Operation General Purpose Input/Output Register - Byte 0 (Indirect Address = 0x00, 047), (Direct Address = 0x0147).</p> <p>When configured as an output pin, the state of this pin can be controlled by writing the appropriate value into Bit 5 (GPIO_5) within the Operation General Purpose Input/Output Register - Byte 0 (Indirect Address = 0x00, 0x47), (Direct Address = 0x0147).</p> <p>ExtLOS_5 (DS3/E3 Framer Block - Channel 5 is enabled). If the DS3/E3 Framer Block is enabled, then this pin will function as the External LOS Input pin for Channel 1. This input pin is intended to be connected to an LOS output pin of a DS3/E3 LIU IC. If this input pin is pulled "High", then the corresponding DS3/E3 Framer block will automatically declare an LOS condition.</p>

GENERAL PURPOSE INPUT/OUTPUT

PIN #	SIGNAL NAME	I/O	SIGNAL TYPE	DESCRIPTION
W21	GPIO_6 ExtLOS_6	I/O	TTL/ CMOS	<p>General Purpose Input/Output Pin or External LOS Input Pin: The function of this input pin depends on whether or not Channel 6 of the DS3/E3 Framer Block is enabled.</p> <p>GPIO_6 (DS3/E3 Framer Block - Channel 6 is disabled). If the DS3/E3 Framer Block is disabled, then this pin will function as a General Purpose Input/Output pin. This input pin can be configured to function as either an input or output pin by writing the appropriate value into Bit 6 (GPIO_DIR_6), within the Operation General Purpose Input/Output Direction Register - 0 (Indirect Address = 0x00, 0x4B), (Direct Address = 0x014B).</p> <p>When configured as an input pin, the state of this pin can be monitored by reading the state of Bit 6 (GPIO_6) within the Operation General Purpose Input/Output Register - Byte 0 (Indirect Address = 0x00, 047), (Direct Address = 0x0147).</p> <p>When configured as an output pin, the state of this pin can be controlled by writing the appropriate value into Bit 6 (GPIO_6) within the Operation General Purpose Input/Output Register - Byte 0 (Indirect Address = 0x00, 0x47), (Direct Address = 0x0147).</p> <p>ExtLOS_6 (DS3/E3 Framer Block - Channel 6 is enabled). If the DS3/E3 Framer Block is enabled, then this pin will function as the External LOS Input pin for Channel 6. This input pin is intended to be connected to an LOS output pin of a DS3/E3 LIU IC. If this input pin is pulled "High", then the corresponding DS3/E3 Framer block will automatically declare an LOS condition.</p>
AE22	GPIO_7 ExtLOS_7	I/O	TTL/ CMOS	<p>General Purpose Input/Output Pin or External LOS Input Pin: The function of this input pin depends on whether or not Channel 7 of the DS3/E3 Framer Block is enabled.</p> <p>GPIO_7 (DS3/E3 Framer Block - Channel 7 is disabled). If the DS3/E3 Framer Block is disabled, then this pin will function as a General Purpose Input/Output pin. This input pin can be configured to function as either an input or output pin by writing the appropriate value into Bit 7 (GPIO_DIR_7), within the Operation General Purpose Input/Output Direction Register - 0 (Indirect Address = 0x00, 0x4B), (Direct Address = 0x014B).</p> <p>When configured as an input pin, the state of this pin can be monitored by reading the state of Bit 7 (GPIO_7) within the Operation General Purpose Input/Output Register - Byte 0 (Indirect Address = 0x00, 047), (Direct Address = 0x0147).</p> <p>When configured as an output pin, the state of this pin can be controlled by writing the appropriate value into Bit 7 (GPIO_7) within the Operation General Purpose Input/Output Register - Byte 0 (Indirect Address = 0x00, 0x47), (Direct Address = 0x0147).</p> <p>ExtLOS_7 (DS3/E3 Framer Block - Channel 7 is enabled). If the DS3/E3 Framer Block is enabled, then this pin will function as the External LOS Input pin for Channel 7. This input pin is intended to be connected to an LOS output pin of a DS3/E3 LIU IC. If this input pin is pulled "High", then the corresponding DS3/E3 Framer block will automatically declare an LOS condition.</p>

GENERAL PURPOSE INPUT/OUTPUT

PIN #	SIGNAL NAME	I/O	SIGNAL TYPE	DESCRIPTION
A25	GPIO_8 ExtLOS_8	I/O	TTL/ CMOS	<p>General Purpose Input/Output Pin or External LOS Input Pin: The function of this input pin depends on whether or not Channel 8 of the DS3/E3 Framer Block is enabled.</p> <p>GPIO_8 (DS3/E3 Framer Block - Channel 8 is disabled). If the DS3/E3 Framer Block is disabled, then this pin will function as a General Purpose Input/Output pin. This input pin can be configured to function as either an input or output pin by writing the appropriate value into Bit 0 (GPIO_DIR_8), within the Operation General Purpose Input/Output Direction Register - 1 (Indirect Address = 0x00, 0x4A), (Direct Address = 0x014A).</p> <p>When configured as an input pin, the state of this pin can be monitored by reading the state of Bit 0 (GPIO_8) within the Operation General Purpose Input/Output Register - Byte 1 (Indirect Address = 0x00, 046), (Direct Address = 0x0146).</p> <p>When configured as an output pin, the state of this pin can be controlled by writing the appropriate value into Bit 0 (GPIO_8) within the Operation General Purpose Input/Output Register - Byte 1 (Indirect Address = 0x00, 0x46), (Direct Address = 0x0146).</p> <p>ExtLOS_8 (DS3/E3 Framer Block - Channel 8 is enabled). If the DS3/E3 Framer Block is enabled, then this pin will function as the External LOS Input pin for Channel 8. This input pin is intended to be connected to an LOS output pin of a DS3/E3 LIU IC. If this input pin is pulled "High", then the corresponding DS3/E3 Framer block will automatically declare an LOS condition.</p>
H24	GPIO_9 ExtLOS_9	I/O	TTL/ CMOS	<p>General Purpose Input/Output Pin or External LOS Input Pin: The function of this input pin depends on whether or not Channel 9 of the DS3/E3 Framer Block is enabled.</p> <p>GPIO_9 (DS3/E3 Framer Block - Channel 8 is disabled). If the DS3/E3 Framer Block is disabled, then this pin will function as a General Purpose Input/Output pin. This input pin can be configured to function as either an input or output pin by writing the appropriate value into Bit 1 (GPIO_DIR_9), within the Operation General Purpose Input/Output Direction Register - 1 (Indirect Address = 0x00, 0x4A), (Direct Address = 0x014A).</p> <p>When configured as an input pin, the state of this pin can be monitored by reading the state of Bit 1 (GPIO_9) within the Operation General Purpose Input/Output Register - Byte 1 (Indirect Address = 0x00, 046), (Direct Address = 0x014A).</p> <p>When configured as an output pin, the state of this pin can be controlled by writing the appropriate value into Bit 1 (GPIO_9) within the Operation General Purpose Input/Output Register - Byte 1 (Indirect Address = 0x00, 0x46), (Direct Address = 0x0146).</p> <p>ExtLOS_9 (DS3/E3 Framer Block - Channel 9 is enabled). If the DS3/E3 Framer Block is enabled, then this pin will function as the External LOS Input pin for Channel 9. This input pin is intended to be connected to an LOS output pin of a DS3/E3 LIU IC. If this input pin is pulled "High", then the corresponding DS3/E3 Framer block will automatically declare an LOS condition.</p>

GENERAL PURPOSE INPUT/OUTPUT

PIN #	SIGNAL NAME	I/O	SIGNAL TYPE	DESCRIPTION
AB23	GPIO_10 ExtLOS_10	I/O	TTL/ CMOS	<p>General Purpose Input/Output Pin or External LOS Input Pin: The function of this input pin depends on whether or not Channel 10 of the DS3/E3 Framer Block is enabled.</p> <p>GPIO_10 (DS3/E3 Framer Block - Channel 10 is disabled). If the DS3/E3 Framer Block is disabled, then this pin will function as a General Purpose Input/Output pin. This input pin can be configured to function as either an input or output pin by writing the appropriate value into Bit 2 (GPIO_DIR_10), within the Operation General Purpose Input/Output Direction Register - 1 (Indirect Address = 0x00, 0x4A), (Direct Address = 0x014A).</p> <p>When configured as an input pin, the state of this pin can be monitored by reading the state of Bit 2 (GPIO_10) within the Operation General Purpose Input/Output Register - Byte 1 (Indirect Address = 0x00, 046), (Direct Address = 0x0146).</p> <p>When configured as an output pin, the state of this pin can be controlled by writing the appropriate value into Bit 2 (GPIO_10) within the Operation General Purpose Input/Output Register - Byte 1 (Indirect Address = 0x00, 0x46), (Direct Address = 0x0146).</p> <p>ExtLOS_10 (DS3/E3 Framer Block - Channel 10 is enabled). If the DS3/E3 Framer Block is enabled, then this pin will function as the External LOS Input pin for Channel 10. This input pin is intended to be connected to an LOS output pin of a DS3/E3 LIU IC. If this input pin is pulled "High", then the corresponding DS3/E3 Framer block will automatically declare an LOS condition.</p>
AD15	GPIO_11 ExtLOS_11	I/O	TTL/ CMOS	<p>General Purpose Input/Output Pin or External LOS Input Pin: The function of this input pin depends on whether or not Channel 11 of the DS3/E3 Framer Block is enabled.</p> <p>GPIO_11 (DS3/E3 Framer Block - Channel 11 is disabled). If the DS3/E3 Framer Block is disabled, then this pin will function as a General Purpose Input/Output pin. This input pin can be configured to function as either an input or output pin by writing the appropriate value into Bit 3 (GPIO_DIR_11), within the Operation General Purpose Input/Output Direction Register - 1 (Indirect Address = 0x00, 0x4A), (Direct Address = 0x014A).</p> <p>When configured as an input pin, the state of this pin can be monitored by reading the state of Bit 3 (GPIO_11) within the Operation General Purpose Input/Output Register - Byte 1 (Indirect Address = 0x00, 046), (Direct Address = 0x0146).</p> <p>When configured as an output pin, the state of this pin can be controlled by writing the appropriate value into Bit 3 (GPIO_11) within the Operation General Purpose Input/Output Register - Byte 1 (Indirect Address = 0x00, 0x46), (Direct Address = 0x0146).</p> <p>ExtLOS_11 (DS3/E3 Framer Block - Channel 11 is enabled). If the DS3/E3 Framer Block is enabled, then this pin will function as the External LOS Input pin for Channel 11. This input pin is intended to be connected to an LOS output pin of a DS3/E3 LIU IC. If this input pin is pulled "High", then the corresponding DS3/E3 Framer block will automatically declare an LOS condition.</p>

CLOCK INPUTS

PIN #	SIGNAL NAME	I/O	SIGNAL TYPE	DESCRIPTION
P23	REFCLK34	I	TTL	E3 Reference Clock Input for the Jitter Attenuator within the DS3/E3 Mapper Block: Apply a signal with a frequency of 34.368±20ppm to this input pin. This input pin functions as the timing reference for the DS3/E3/STS-1 Jitter Attenuator (within the DS3/E3 Mapper block) for E3 applications.
P24	REFCLK51	I	TTL	STS-1 Reference Clock Input for the Jitter Attenuator within the DS3/E3 Mapper Block: The user is expected to apply a signal with a frequency of 51.84MHz±20ppm to this input pin. This input pin functions as the timing reference for the DS3/E3/STS-1 Jitter Attenuator (within the DS3/E3 Mapper block) for STS-1 applications.
P25	REFCLK45	I	TTL	DS3 Reference Clock Input for the Jitter Attenuator within the DS3/E3 Mapper Block: Apply a signal with a frequency of 44.736±20ppm to this input pin. This input pin functions as the timing reference for the DS3/E3/STS-1 Jitter Attenuator (within the DS3/E3 Mapper block) for DS3 applications.

BOUNDARY SCAN

PIN #	SIGNAL NAME	I/O	SIGNAL TYPE	DESCRIPTION
B2	TDO	O		
C2	TDI	I		
B1	TRST	I		
G5	TCK	I		
H6	TMS	I		

MISCELLANEOUS PINS

PIN #	SIGNAL NAME	I/O	SIGNAL TYPE	DESCRIPTION
L21	Test Mode	I		Test Mode Input Pin: Tie this input pin "Low" for normal operation.

POWER SUPPLY PINS

PIN #	SIGNAL NAME	I/O	SIGNAL TYPE	DESCRIPTION
VDD = 3.3V				
N6 N5 P3 R3	Analog VDD Pins (Transmitter)	–		Transmitter Analog Power Supply Voltage = 3.3V Nominal
P4	Analog VDD Pins (PLL)			PLL Analog Power Supply Voltage = 3.3V Nominal
L1	Analog VDD Pins (Receiver)			Receiver Analog Power Supply Voltage = 3.3V Nominal
U6 R15 R16 P15 P16 N15 N16 M15 M16 L15 L16 AA10 AA11 AA9 F10 F11 F9 K21	Digital VDD			Digital Power Supply Voltage = 3.3V Nominal
VDD (2.5V)				
P6 M4 N21 N26 P22	Analog VDD Pins (PLL)			PLL Analog Power Supply Voltage = 2.5 V Nominal
R6	Analog VDD Pins (Transmitter)			Transmitter Analog Power Supply Voltage = 2.5 V Nominal

POWER SUPPLY PINS

PIN #	SIGNAL NAME	I/O	SIGNAL TYPE	DESCRIPTION
L6	Analog VDD Pins (Receiver)			Receiver Analog Power Supply Voltage = 2.5 V Nominal
U21 R11 R12 P11 P12 N11 N12 M11 M12 L11 L12 K6 F16 F17 F18 AA16 AA17 AA18	Digital VDD			Digital Power Supply Voltage = 2.5 V Nominal

GROUND

PIN #	SIGNAL NAME	I/O	SIGNAL TYPE	DESCRIPTION
Y6 Y21 T11 T12 T13 T14 T15 T16 R13 R14 P13 P14 N13 N14 M13 M14 L13 L14 G6 G21 F6 F21 F13 F14 AA6 AA21 AA13 AA14	GND	-		Ground
N3 N4 M3 R5 P5 T6 L2 M6 M21 N24 N25 N22 N23 P21	Analog Ground			
NO CONNECTS				
M23	NC			

XRT94L43

SONET/SDH OC-12 TO 12XDS3/E3 MAPPER

GROUND

PIN #	SIGNAL NAME	I/O	SIGNAL TYPE	DESCRIPTION
M26	NC			
T5	NC			

DC ELECTRICAL CHARACTERISTICS

DC CHARACTERISTICS FOR TTL INPUT/CMOS OUTPUT

Applies to all TTL-Level Input and CMOS Level Output pins - Ambient Temperature = 25°C						
SYMBOL	PARAMETER	MIN	MAX	UNITS	CONDITION	
VDDQ	I/O Supply Voltage	3.135	3.465	V		
VIH	High-Level Input Voltage	2.0	VDD+0.3	V	VOUT ≥ VOH(min)	
VIL	Low-Level Input Voltage	-0.3	0.3*VDD	V	VOUT ≤ VOL(max)	
VOH	High-Level Output Voltage	1.9		V	VDD = MIN VIN = VIH	IOH = -2mA
VOL	Low-Level Output Voltage		0.6	V	VDD = MIN VIN = VIL	IOL = 2mA
II	Input Current		±15	µA	VDD = MAX VIN = VDD or GND	

DC CHARACTERISTICS FOR LVPECL I/O

Applies to all LVPECL Input and Output pins						
SYMBOL	PARAMETER	MIN	MAX	UNITS	CONDITION	
VIH	High-Level Input Voltage		VDD+0.4	V		
VIL	Low-Level Input Voltage	-0.4		V		
VICM	Input Common Mode Voltage	1.0	VDD	V		
VINDIFF	Differential Input Voltage	0.2		V		
VOH	High-Level Output Voltage	VDD-1.08	VDD-0.88	V		
VOL	Low-Level Output Voltage	VDD-1.88	VDD-1.62	V		
VOUTDIFF	Differential Output Voltage	1.18	2.12	V		

AC ELECTRICAL CHARACTERISTICS

1.0 MICROPROCESSOR INTERFACE TIMING FOR REVISION D SILICON

1.1 MICROPROCESSOR INTERFACE TIMING - ASYNCHRONOUS INTEL MODE

FIGURE 5. ASYNCHRONOUS MODE 1 - INTEL TYPE PROGRAMMED I/O TIMING (WRITE CYCLE)

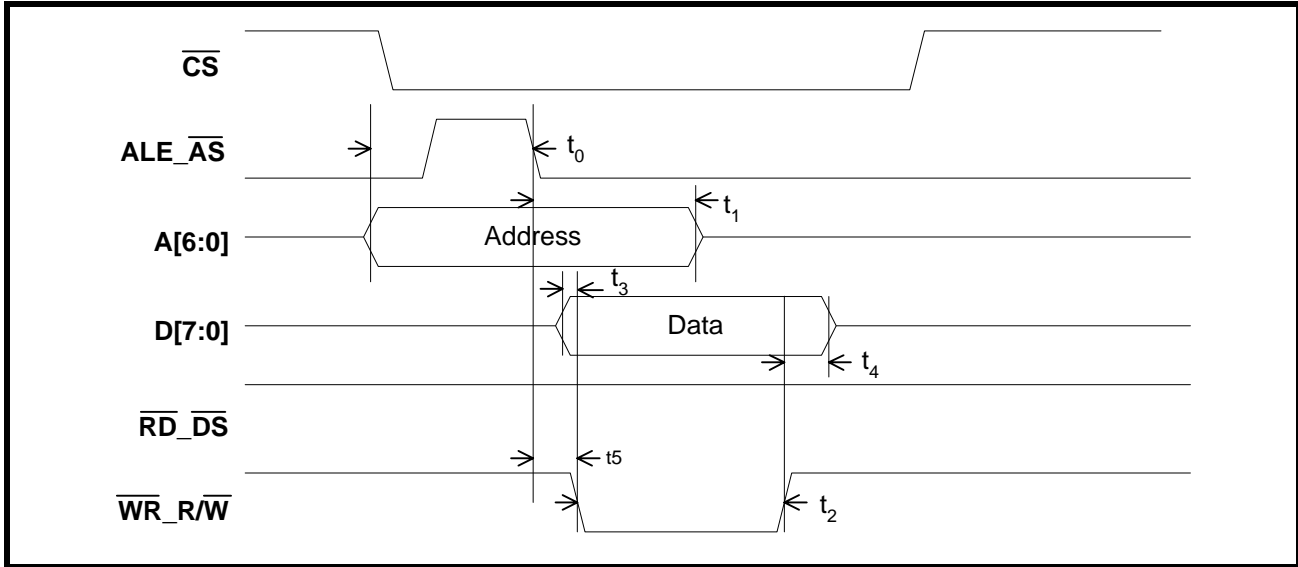

NOTE: The values for t_0 through t_7 , within this figure can be found in [Table 1](#).

FIGURE 6. ASYNCHRONOUS MODE 1 - INTEL TYPE PROGRAMMED I/O TIMING (READ CYCLE)

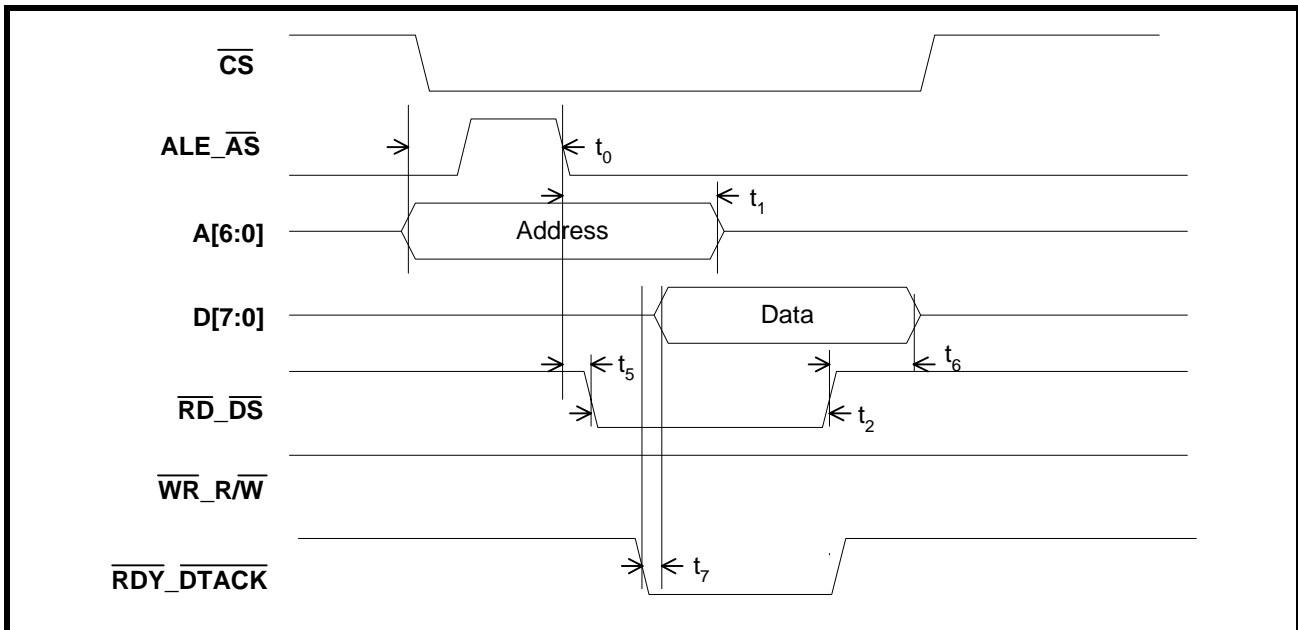

NOTE: The values for t_0 through t_7 , within this figure can be found in [Table 1](#).

TABLE 1: TIMING INFORMATION FOR THE MICROPROCESSOR INTERFACE, WHEN CONFIGURED TO OPERATE IN THE INTEL ASYNCHRONOUS MODE

TIMING	DESCRIPTION	MIN.	TYP.	MAX.
t_0	Address setup time to pALE low	6	-	-
t_1	Address hold time to pALE low	6	-	-
t_2	pRD_L, pWR_L pulse width	320	-	-
t_3	Data setup time to pWR_L low	0	-	-
t_4	Data hold time to pWR_L high	0	-	-
t_5	pALE low to pRD_L, pWR_L low	5	-	-
t_6	Data invalid from pRD_L high	7	-	-
t_7	Data valid from pRDY_L low	-	-	0

NOTE: Test Conditions: $T_A = 25^\circ\text{C}$, $V_{CC} = 3.3V \pm 5\%$ and $2.5V \pm 5\%$, unless otherwise specified.

1.2 MICROPROCESSOR INTERFACE TIMING - ASYNCHRONOUS MOTOROLA (68K) MODE

FIGURE 7. ASYNCHRONOUS MODE 2 - MOTOROLA 68K PROGRAMMED I/O TIMING (WRITE CYCLE)

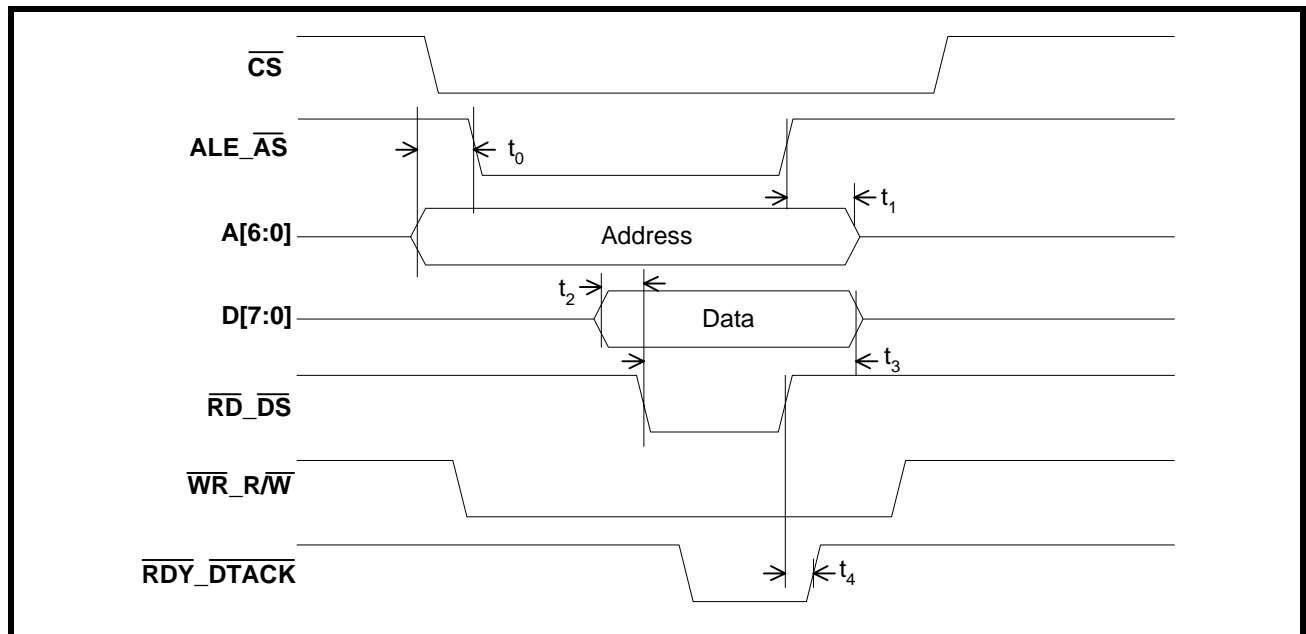

NOTE: The values for t_0 through t_7 can be found in [Table 2](#).

FIGURE 8. ASYNCHRONOUS MODE 2 - MOTOROLA 68K PROGRAMMED I/O TIMING (READ CYCLE)

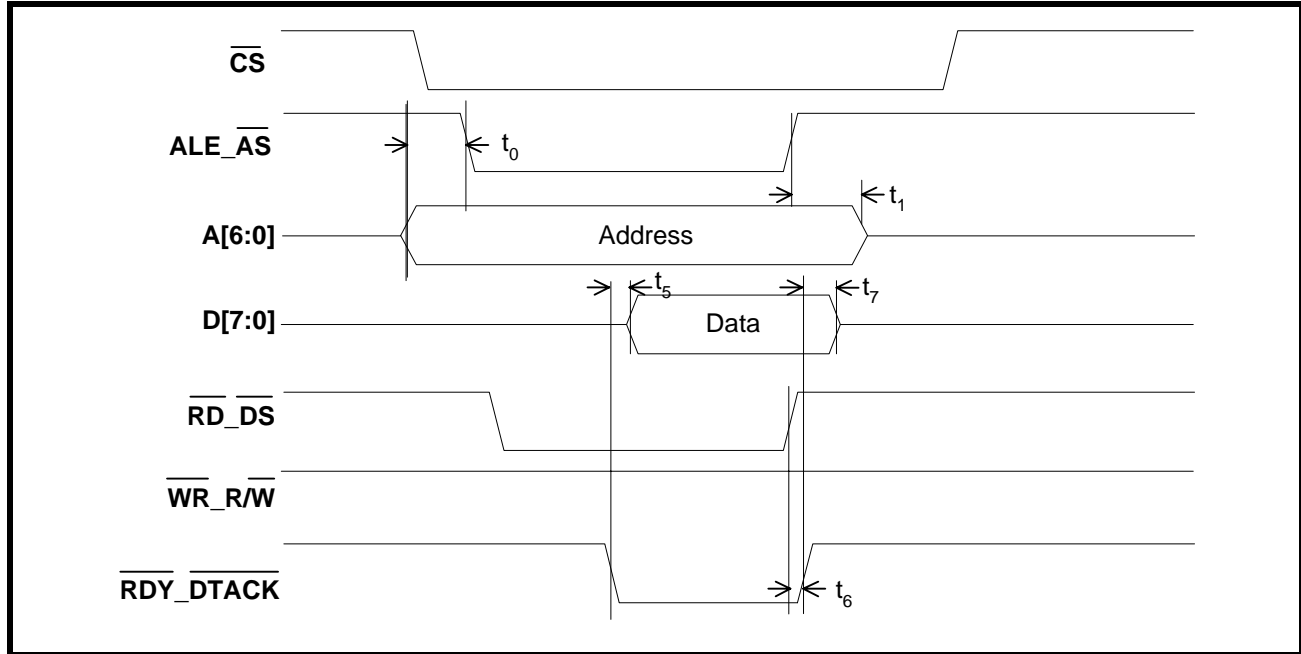

NOTE: The values for t_0 through t_7 can be found in Table 2.

TABLE 2: TIMING INFORMATION FOR THE MICROPROCESSOR INTERFACE WHEN CONFIGURED TO OPERATE IN THE MOTOROLA (68K) ASYNCHRONOUS MODE

TIMING	DESCRIPTION	MIN.	TYP.	MAX
t_0	Address setup time to pALE low	6	-	-
t_1	Address hold time to pALE high	6	-	-
t_2	Data setup time to pDS_L low	0	-	-
t_3	Data hold time to pDS_L low	160	-	-
t_4	pDS_L high to pRDY_L high (Write Cycle)	-	-	16
t_5	pRDY_L low to Data valid	-	-	15
t_6	pDS_L high to pRDY_L high (Read Cycle)	-	-	16
t_7	pRDY_L high to Data invalid	3	-	-

NOTE: Test Conditions: $T_A = 25^\circ\text{C}$, $V_{CC} = 3.3\text{V} \pm 5\%$ and $2.5\text{V} \pm 5\%$, unless otherwise specified.

1.3 MICROPROCESSOR INTERFACE TIMING - POWER PC 403 SYNCHRONOUS MODE

FIGURE 9. SYNCHRONOUS MODE 3 - IBM POWERPC 403 INTERFACE TIMING (WRITE CYCLE)

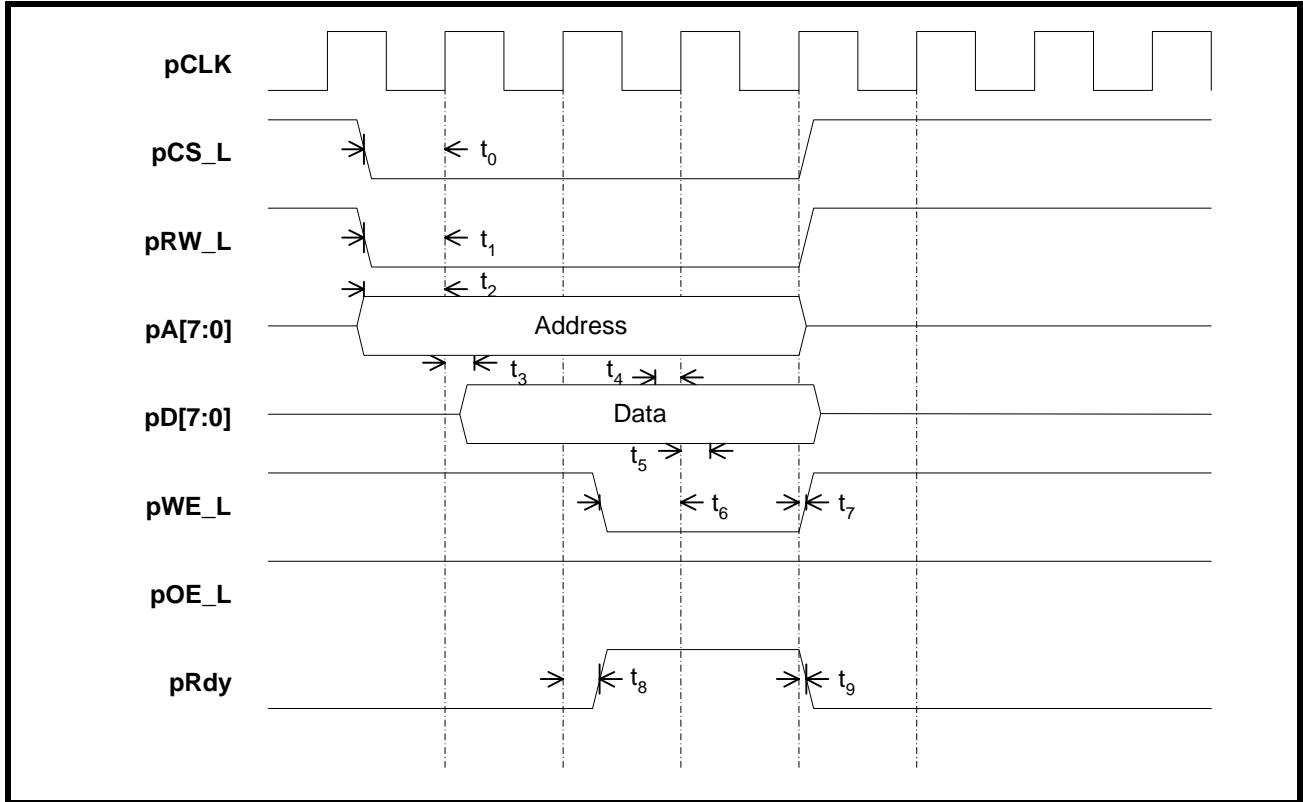

NOTE: The value for t_0 through t_{12} can be found in **Table 3**.

FIGURE 10. SYNCHRONOUS MODE 3 - IBM POWERPC 403 INTERFACE TIMING (READ CYCLE)

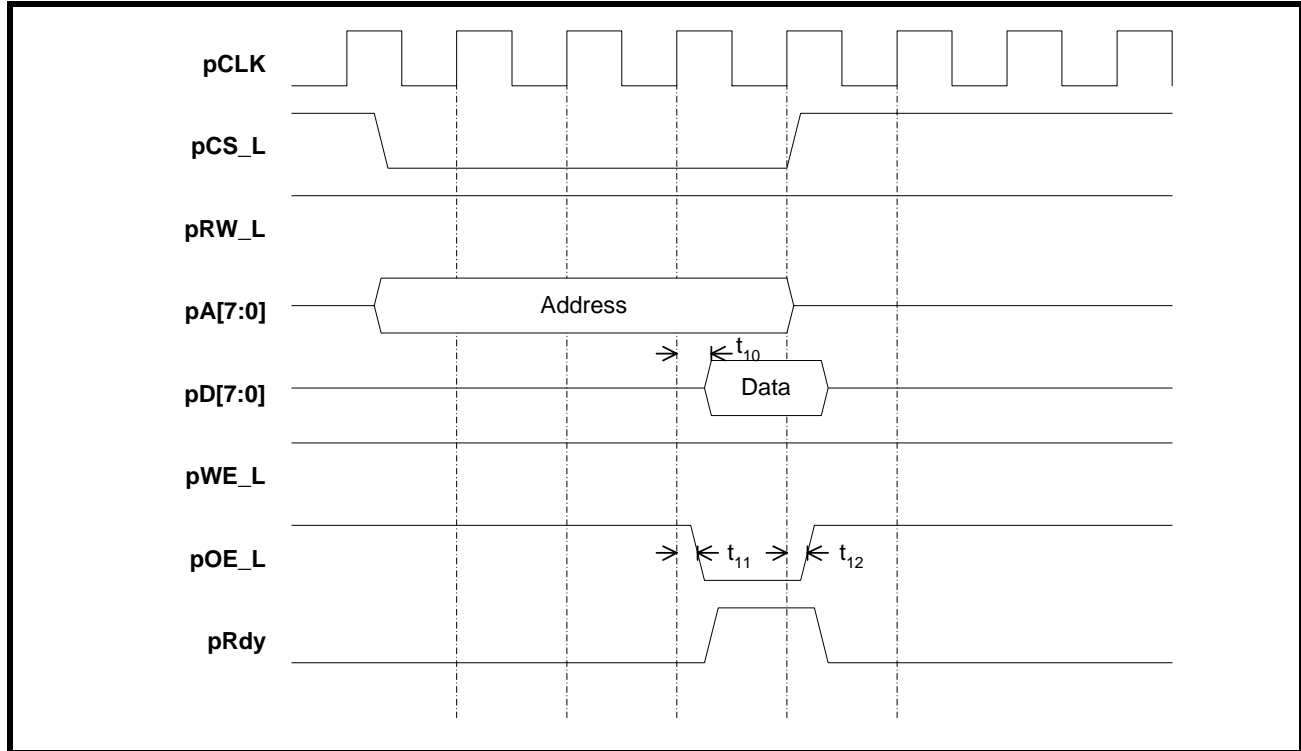

NOTE: The value for t_0 through t_{12} can be found in Table 3.

TABLE 3: TIMING INFORMATION FOR THE MICROPROCESSOR INTERFACE, WHEN CONFIGURED TO OPERATE IN THE IBM POWER PC403 MODE

TIMING	DESCRIPTION	MIN.	TYP.	MAX.
t_0	pCS_L low to Clock high	10	-	-
t_1	pRW_L low to Clock high	9	-	-
t_2	Address setup time	9	-	-
t_3	Address hold time	5	-	-
t_4	Data setup time (WRITE cycle)	9	-	-
t_5	Data hold time (WRITE cycle)	0	-	-
t_6	pWE_L low to Clock high	6	-	-
t_7	Clock high to pWE_L high	6	-	-
t_8	Clock high to pRDY high	-	-	10
t_9	Clock high to pRDY low	-	-	10
t_{10}	Clock high to Data valid (READ cycle)	-	-	11
t_{11}	Clock high to pOE_L low	11	-	-
t_{12}	Clock high to pOE_L high	11	-	-

NOTE: Test Conditions: $T_A = 25^\circ\text{C}$, $V_{CC} = 3.3\text{V} \pm 5\%$ and $2.5\text{V} \pm 5\%$, unless otherwise specified.

1.4 MICROPROCESSOR INTERFACE TIMING - IDT3051/52 MODE

FIGURE 11. SYNCHRONOUS MODE 4 - IDT3051/52 INTERFACE TIMING (WRITE CYCLE)

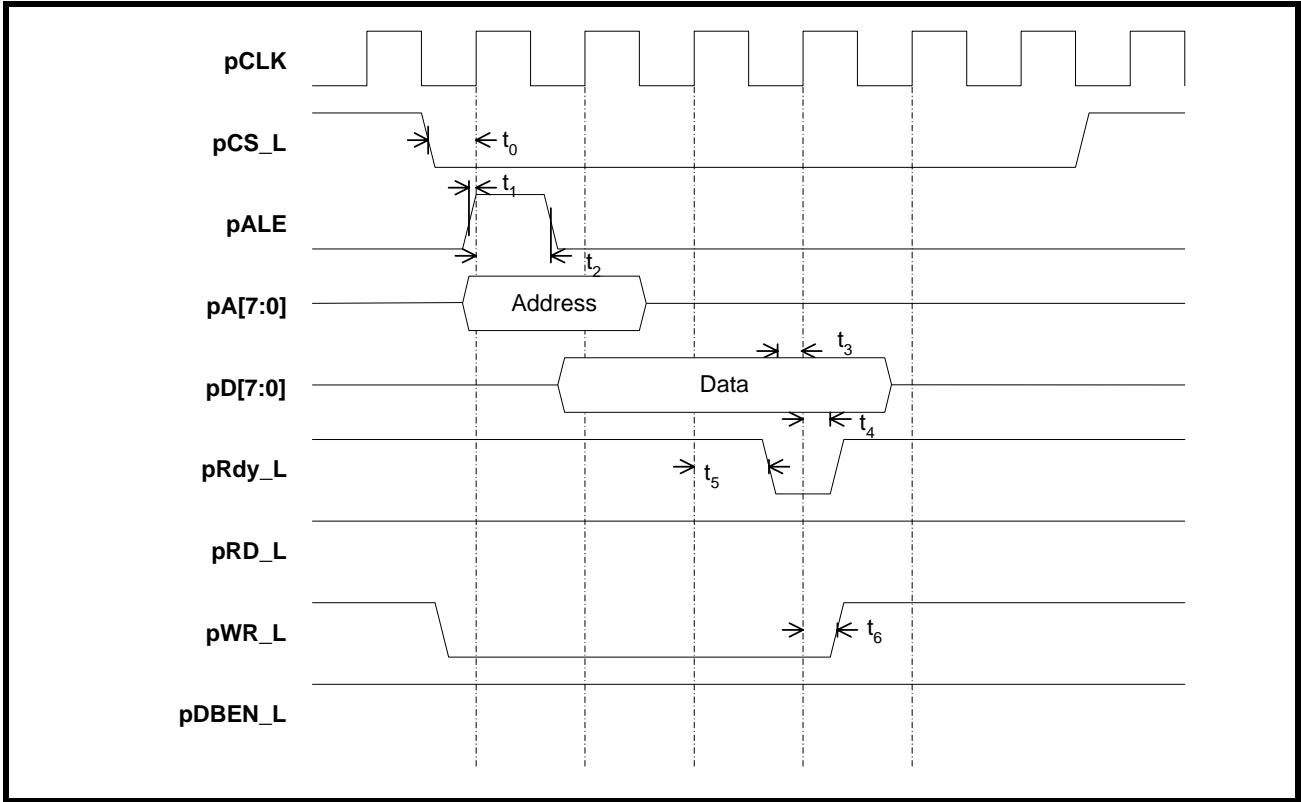

NOTE: The values for t_0 through t_{11} can be found in [Table 4](#).

FIGURE 12. SYNCHRONOUS MODE 4 - IDT3051/52 INTERFACE TIMING (READ CYCLE)

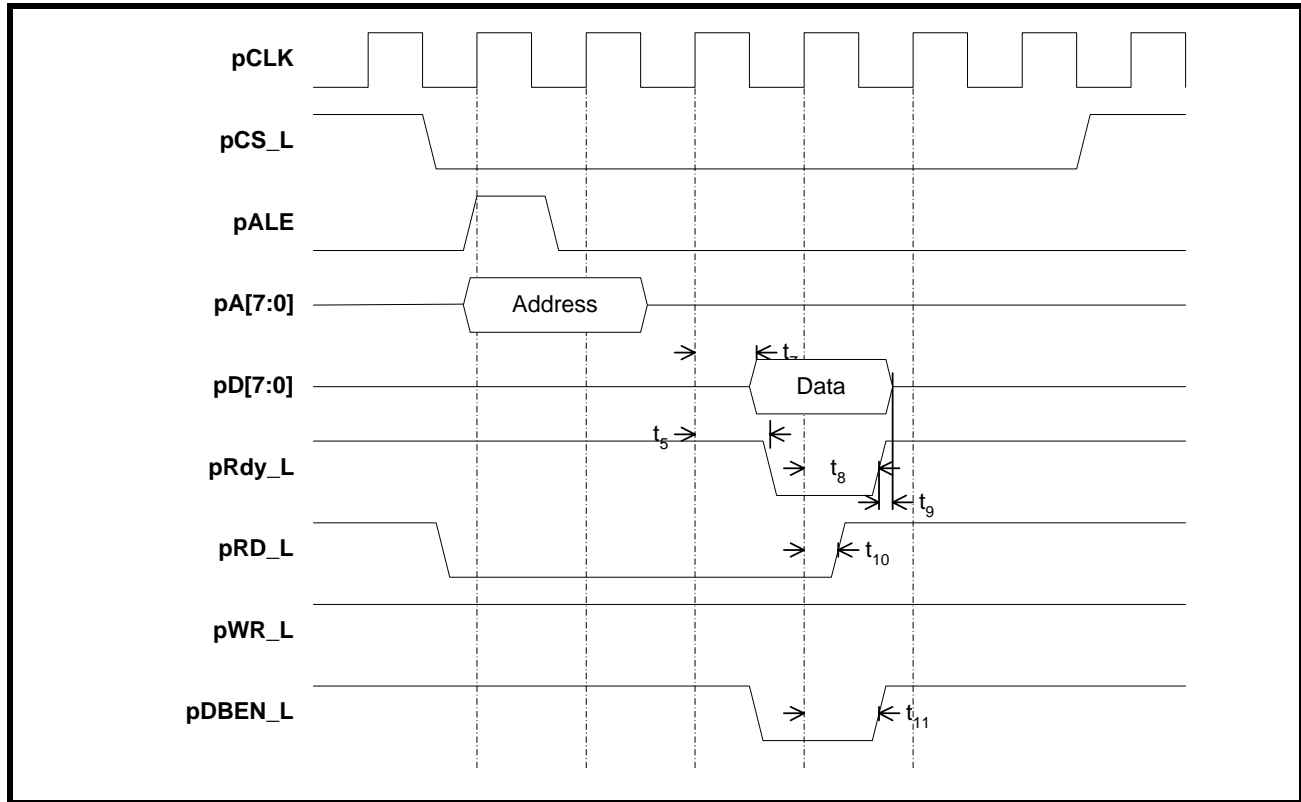

NOTE: The values for t_0 through t_{11} can be found in Table 4.

TABLE 4: TIMING INFORMATION FOR THE MICROPROCESSOR INTERFACE, WHEN CONFIGURED TO OPERATE IN THE IDT3051/52 MODE

TIMING	DESCRIPTION	MIN.	TYP.	MAX.
t_0	pCS_L low to Clock high	6	-	-
t_1	pALE high to Clock high	1	-	-
t_2	Clock high to pALE low	6	-	-
t_3	Data setup time (WRITE cycle)	-	-	N/N
t_4	Data hold time (WRITE cycle)	-	-	N/N
t_5	Clock high to pRDY_L low	-	-	11
t_6	Clock high to pWR_L high	6	-	-
t_7	Clock high to Data valid (READ cycle)	-	-	N/N
t_8	Clock high to pRDY_L high	-	-	11
t_9	pRDY_L high to Data invalid	0	-	-
t_{10}	Clock high to pRD_L high	11	-	-
t_{11}	Clock high to pDBEN_L high	10	-	-

NOTE: Test Conditions: $T_A = 25^\circ\text{C}$, $V_{CC} = 3.3\text{V} \pm 5\%$ and $2.5\text{V} \pm 5\%$, unless otherwise specified.

2.0 STS-12/STM-4 TELECOM BUS INTERFACE TIMING INFORMATION

2.1 STS-12/STM-4 Telecom Bus Interface Timing Information

This section presents the timing requirements for the STS-12/STM-4 Telecom Bus Interface. In particular this section indicates the following.

- a. Identifies which edge of TxA_CLK in which the TxA_D[7:0], TxA_PL, TxA_C1J1, TxA_ALARM and TxA_DP output pins are updated on.
- b. The clock to output delays (from the rising edge of TxA_CLK to the instant that the TxA_D[7:0], TxA_PL, TxA_C1J1, TxA_ALARM and TxA_DP output pins are updated).
- c. The set-up and hold-time requirements of TxSBFP with respect to the REFCLK input.
- d. Identifies which edge of RxD_CLK that the RxD_D[7:0], RxD_PL, RxD_C1J1, RxD_ALARM and RxD_DP input pins are sampled on.
- e. The set-up time requirements (from an update in the RxD_D[7:0], RxD_PL, RxD_C1J1, RxD_ALARM and RxD_DP input signals to the rising edge of RxD_CLK).
- f. The hold-time requirements (from the rising edge of RxD_CLK to a change in the RxD_D[7:0], RxD_PL, RxD_C1J1, RxD_ALARM and RxD_DP input signals)

2.2 The Transmit STS-12/STM-4 Telecom Bus Interface Timing

In the Transmit STS-12/STM-4 Telecom Bus Interface, all of the signals (which are output via this Bus Interface) are updated upon the rising edge of TxA_CLK (77.76MHz clock signal).

Figure 13 and Figure 14 presents an illustration of the waveforms of the signals that will be output via the Transmit STS-12/STM-4 Telecom Bus Interface, as well as the timing parameter (t_1).

FIGURE 13. WAVEFORMS OF THE SIGNALS THAT ARE OUTPUT VIA THE TRANSMIT STS-12/STM-4 TELECOM BUS INTERFACE

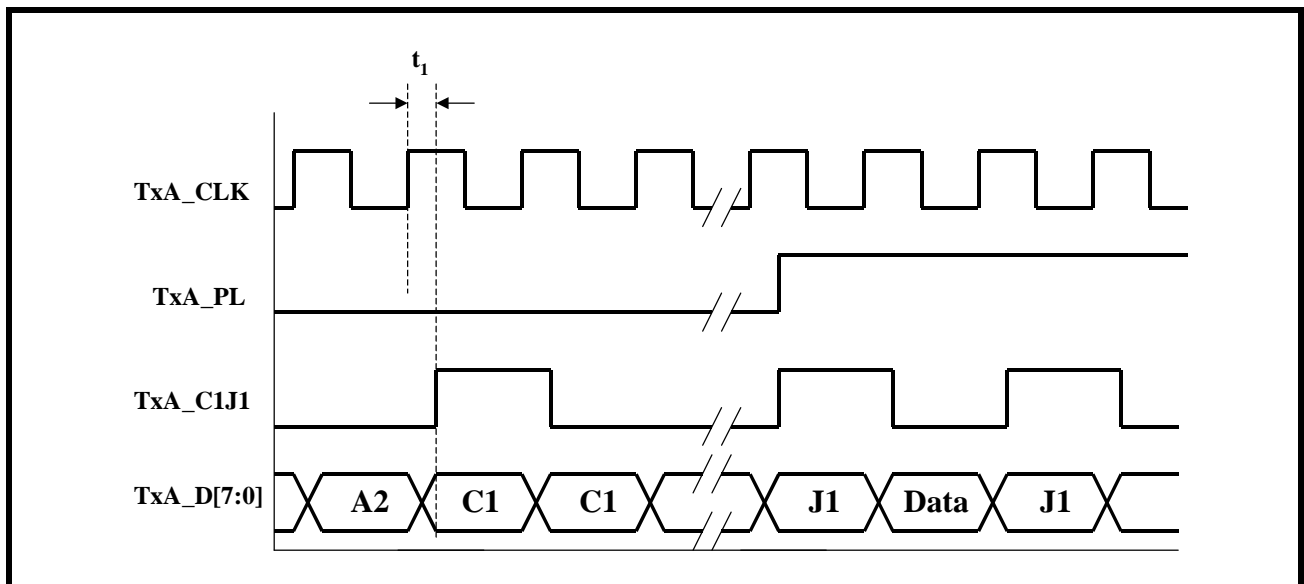

NOTE: The value for t_1 can be found in **Table 5**.

The TxSBFP input signal is sampled upon the rising edge of TxA_CLK by the Transmit STS-12/STM-4 Telecom Bus Interface circuitry, as illustrated below in Figure 14.

FIGURE 14. TIMING RELATIONSHIPS BETWEEN THE TxSBFP INPUT PIN AND THE TxA_CLK OUTPUT PIN WITHIN THE TRANSMIT STS-12/STM-4 TELECOM BUS INTERFACE

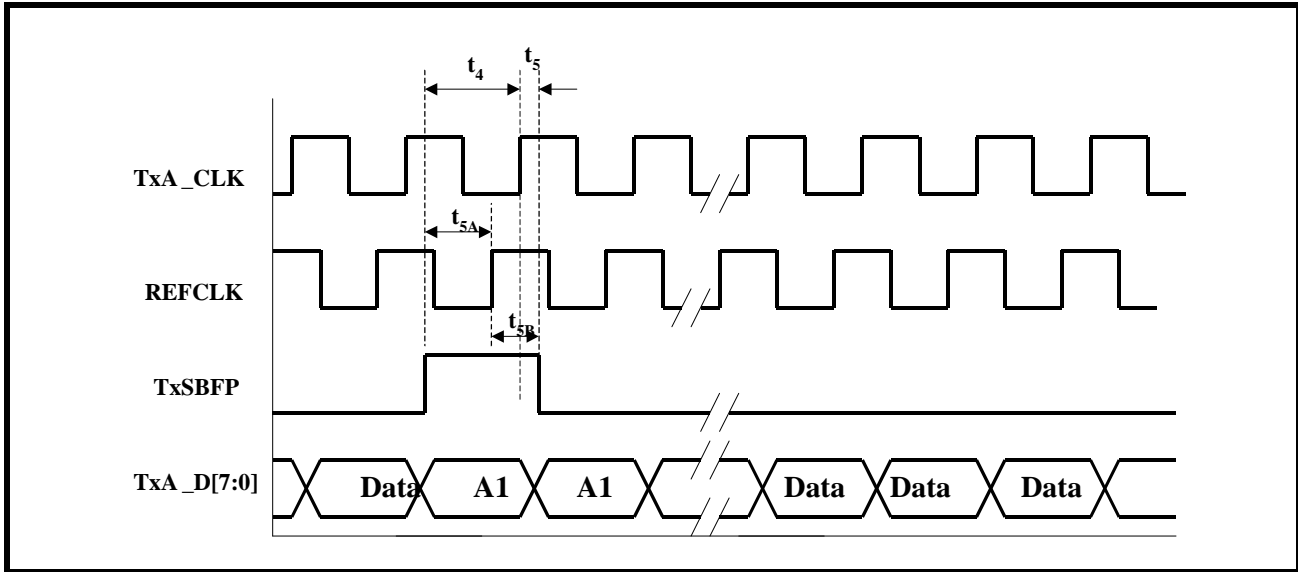

NOTE: The value for t_4 , t_5 , t_{5A} and t_{5B} can be found in Table 5.

Table 5 presents information on the Timing parameters for the Transmit STS-12/STM-4 Telecom Bus Interface.

TABLE 5: TIMING INFORMATION FOR THE TRANSMIT STS-12/STM-4 TELECOM BUS INTERFACE

SYMBOL	DESCRIPTION	MIN.	TYP.	MAX.
t_1	Rising edge of TxA_CLK to updates in TxA_D[7:0], TxA_PL, TxA_C1J1 and TxA_DP	3.7ns		9.5ns
t_4	TxSBFP Set-up time to rising edge of TxA_CLK	8.5ns		
t_5	TxA_CLK rising edge to TxSBFP Hold time	0ns		
t_{5A}	TxSBFP Set-up time to rising edge of REFCLK	5ns		
t_{5B}	Rising edge of REFCLK to TxSBFP Hold Time	0ns		

2.3 The Receive STS-12/STM-4 Telecom Bus Interface Timing

In the Receive STS-12/STM-4 Telecom Bus Interface, all of the signals (which are input via this Bus Interface) are sampled upon the rising edge of RxD_CLK (77.76MHz clock signal).

Figure 15 presents an illustration of the waveforms and the timing parameters (t_2 and t_3) of the signals that will be received by the Receive STS-12/STM-4 Telecom Bus Interface.

FIGURE 15. WAVEFORMS OF THE SIGNALS THAT ARE INPUT VIA THE RECEIVE STS-12/STM-4 TELECOM BUS INTERFACE

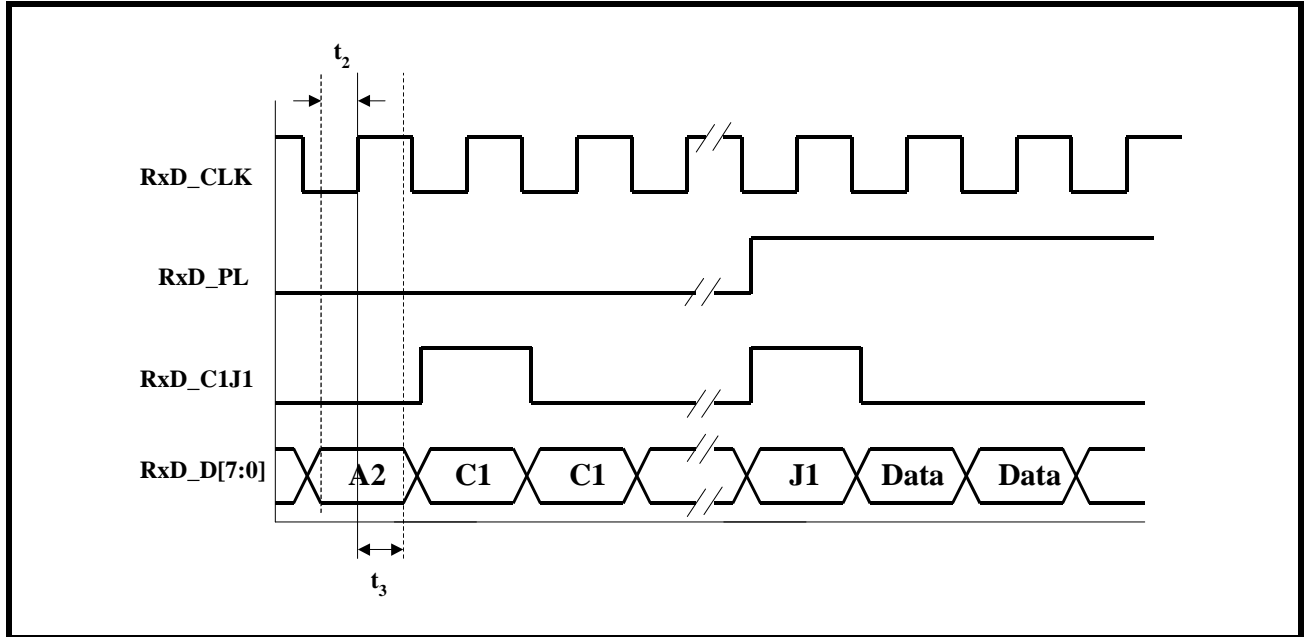

NOTE: The value for t_2 and t_3 can be found in [Table 6](#).

[Table 6](#) presents information on the Timing parameters for the Receive STS-12/STM-4 Telecom Bus Interface.

TABLE 6: TIMING INFORMATION FOR THE RECEIVE STS-12/STM-4 TELECOM BUS INTERFACE

SYMBOL	DESCRIPTION	MIN.	TYP.	MAX.
t_2	RxD_D[7:0], RxD_PL, RxD_C1J1, RxD_ALARM and RxD_DP to rising edge of RxD_CLK set-up time requirements	3 ns		
t_3	Rising edge of RxD_CLK to RxD_D[7:0], RxD_PL, RxD_C1J1, RxD_ALARM and RxD_DP hold time requirements	0 ns		

3.0 STS-12/STM-4 PECL INTERFACE TIMING INFORMATION

3.1 The Receive STS-12/STM-4 PECL Interface Timing

The Receive STS-12/STM-4 PECL Interface block samples the incoming STS-12/STM-4 signal (which is present on the RxL_Data_p/RxL_Data_n input pins) upon the rising edge of the RxL_CLKL_p/RxL_CLKL_n input clock signal.

FIGURE 16. WAVEFORMS OF THE SIGNALS THAT ARE INPUT VIA THE RECEIVE STS-12/STM-4 PECL INTERFACE

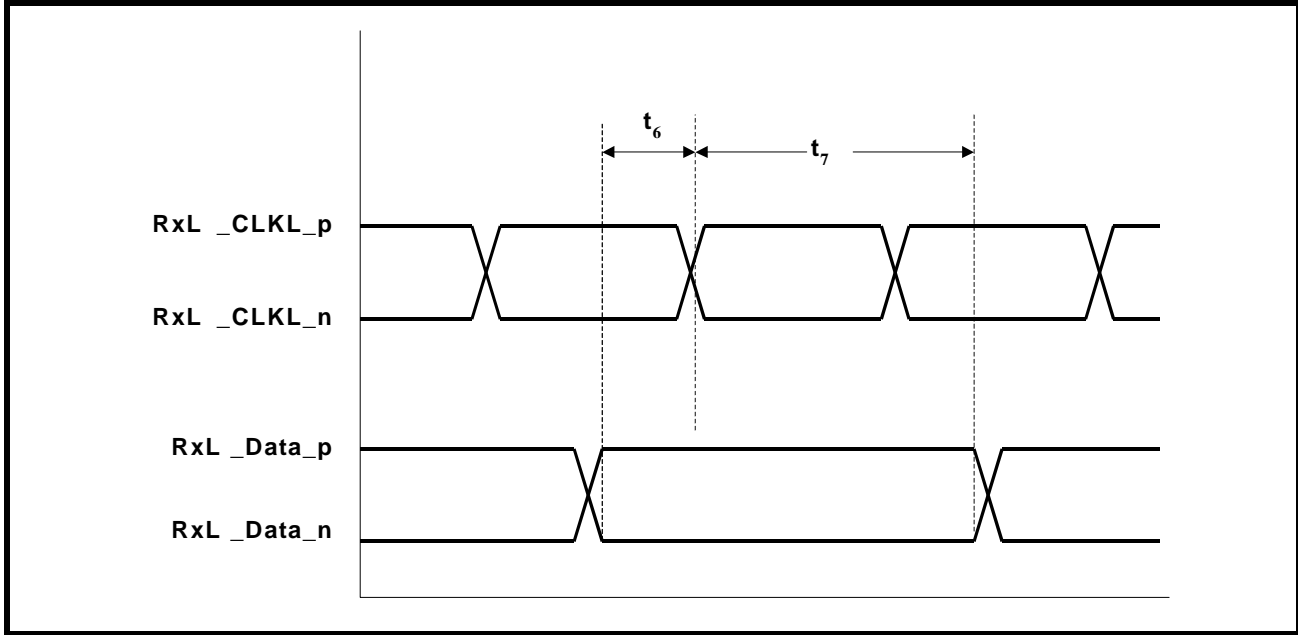

NOTE: Table 7 presents information on the Timing parameters for the Receive STS-12/STM-4 PECL Interface

TABLE 7: TIMING INFORMATION FOR THE RECEIVE STS-12/STM-4 PECL INTERFACE

SYMBOL	DESCRIPTION	MIN.	TYP.	MAX.
t_6	RxL_DATA to rising edge of RxL_CLKL set-up time requirements	200ps		
t_7	Rising edge of RxL_CLKL to RxL_DATA hold time requirements	200ps		

NOTE: These timing requirements apply to both the Primary and the Redundant Receive STS-12/STM-4 PECL Interface blocks.

3.2 The Transmit STS-12/STM-4 PECL Interface Block

The outbound STS-12/STM-4 data (from the Transmit STS-12/STM-4 PECL Interface block) is updated upon the rising edge of TxLCLKO_p/TxLCLKO_n via the TxLData_p/TxLData_n output pins.

FIGURE 17. WAVEFORMS OF THE TRANSMIT STS-12/STM-4 PECL INTERFACE SIGNALS

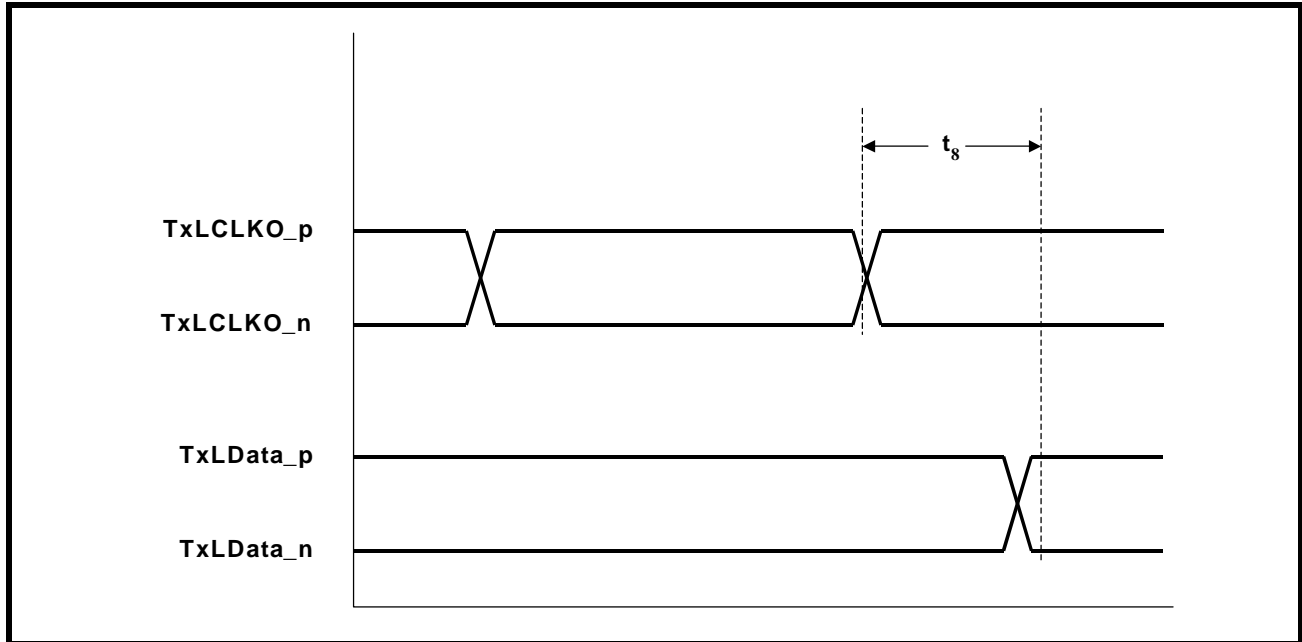

Table 8 presents information on the Timing Parameter for the Transmit STS-12/STM-4 PECL Interface

TABLE 8: TIMING INFORMATION FOR THE TRANSMIT STS-12/STM-4 PECL INTERFACE

SYMBOL	DESCRIPTION	MIN.	TYP.	MAX.
t_8	Rising edge of TxLCLKO to TxLData out delay	600ps	800ps	1ns

NOTE: These timing requirements apply to both the Primary and the Redundant Transmit STS-12/STM-4 PECL Interface block.

4.0 DS3/E3/STS-1 LIU INTERFACE TIMING INFORMATION

4.1 Ingress DS3/E3/STS-1 Interface Timing

The user should be aware of the following things about the Ingress DS3/E3/STS-1 Interface Timing.

- a. If a given channel is configured to operate in the DS3/E3 Mode, then the DS3/E3 Framer block can be configured to sample the DS3/E3/STS_1_DATA_IN and the DS3/E3/STS_1_NEG_IN input pins upon either the rising or falling edge of DS3/E3/STS_1_CLOCK.
- b. If a given channel is configured to operate in the STS-1/STM-0 Mode, then the Receive STS-1 TOH Processor block will be operating in the Single-Rail Mode (e.g., the Receive STS-1 TOH Processor block will ONLY sample the DS3/E3/STS_1_DATA_IN input signal. It will not sample the DS3/E3/STS_1_NEG_IN input signal.
- c. Further, if a given channel is configured to operate in the STS-1/STM-0 Mode, then the Receive STS-1 TOH Processor block can ONLY be configured to sample the DS3/E3/STS_1_DATA_IN input signal, upon the rising edge of DS3/E3/STS_1_CLOCK_IN. The Receive STS-1 TOH Processor block CANNOT be configured to sample the DS3/E3/STS_1_DATA_IN input signal upon the falling edge of DS3/E3/STS_1_CLOCK_IN.

The Timing Diagram for the Ingress DS3/E3/STS-1 Interface is presented below in **Figure 18**.

FIGURE 18. WAVEFORMS OF THE DS3/E3/STS-1 SIGNALS THAT ARE INPUT TO THE DS3/E3/STS-1 LIU INTERFACE IN THE INGRESS DIRECTION

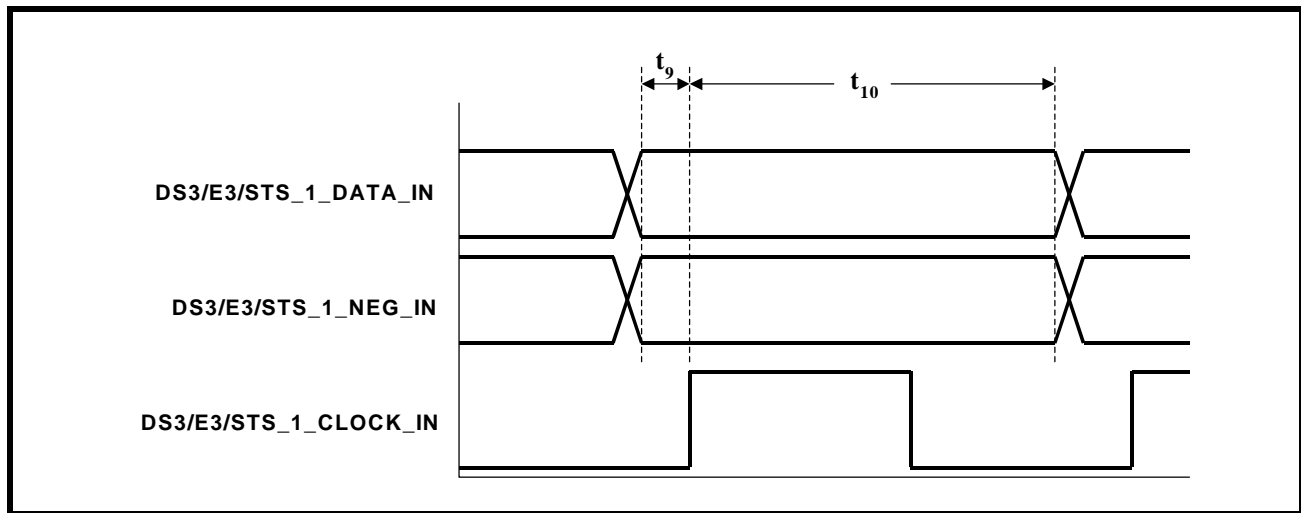

NOTE: The values for t_9 and t_{10} are presented in **Table 9**, **Table 10** and **Table 11**.

4.2 Ingress Timing for DS3/E3 Applications

Table 9 presents information on the Timing parameters for the DS3/E3/STS-1 LIU Interface Signals (in the Ingress Direction) for DS3/E3 Applications, and when the DS3/E3 Framer block has been configured to sample the DS3/E3/STS_1_DATA_IN and DS3/E3/STS_1_NEG_IN signals upon the rising edge of DS3/E3/STS_1_CLOCK_IN.

TABLE 9: TIMING INFORMATION FOR THE INGRESS DS3/E3/STS-1 LIU INTERFACE FOR DS3/E3 APPLICATIONS WHEN THE DS3/E3 FRAMER BLOCK HAS BEEN CONFIGURED TO SAMPLE THE DS3/E3/STS_1_DATA_IN AND DS3/E3/STS_1_NEG_IN INPUT PINS UPON THE RISING EDGE OF DS3/E3/STS_1_CLOCK_IN

SYMBOL	DESCRIPTION	MIN.	TYP.	MAX.
t_9	DS3/E3/STS_1_DATA_IN and DS3/E3/STS_1_NEG_IN to rising edge of DS3/E3/STS_1_CLOCK_IN set-up time requirements	7ns		
t_{10}	Rising edge of DS3/E3/STS_1_CLOCK_IN to DS3/E3/STS_1_DATA_IN and DS3/E3/STS_1_NEG_IN Hold time requirements	0ns		

Table 10 presents information on the Timing parameters for the DS3/E3/STS-1 LIU Interface Signals (in the Ingress Direction) for DS3/E3 Applications, and when the DS3/E3 Framer block has been configured to sample the DS3/E3/STS_1_DATA_IN and DS3/E3/STS_1_NEG_IN signals upon the falling edge of DS3/E3/STS_1_CLOCK_IN.

TABLE 10: TIMING INFORMATION FOR THE INGRESS DS3/E3/STS-1 LIU INTERFACE FOR DS3/E3 APPLICATIONS AND WHEN THE DS3/E3 FRAMER BLOCK HAS BEEN CONFIGURED TO SAMPLE THE DS3/E3/STS_1_DATA_IN AND DS3/E3/STS_1_NEG_IN INPUT PINS UPON THE FALLING EDGE OF DS3/E3/STS_1_CLOCK_IN

SYMBOL	DESCRIPTION	MIN.	TYP.	MAX.
t_9	DS3/E3/STS_1_DATA_IN and DS3/E3/STS_1_NEG_IN to falling edge of DS3/E3/STS_1_CLOCK_IN set-up time requirements	7ns		
t_{10}	Falling edge of DS3/E3/STS_1_CLOCK_IN to DS3/E3/STS_1_DATA_IN and DS3/E3/STS_1_NEG_IN Hold time requirements	0ns		

4.3 Ingress Timing for STS-1/STM-0 Applications

Table 11 presents information on the Timing parameters for the DS3/E3/STS-1 LIU Interface Signals (in the Ingress Direction) for STS-1/STM-0 Applications.

TABLE 11: TIMING INFORMATION FOR THE INGRESS DS3/E3/STS-1 LIU INTERFACE FOR STS-1/STM-0 APPLICATIONS

SYMBOL	DESCRIPTION	MIN.	TYP.	MAX.
t_9	DS3/E3/STS_1_DATA_IN to rising edge of DS3/E3/STS_1_CLOCK_IN set-up time requirements	4ns		
t_{10}	Rising edge of DS3/E3/STS_1_CLK_IN to DS3/E3/STS_1_DATA_IN and DS3/E3/STS_1_CLOCK_IN Hold time requirements	0ns		

4.4 The Egress DS3/E3/STS-1 Interface Timing

The user should be aware of the followings things about the Egress DS3/E3/STS-1 Interface timing.

- a. If a given channel is configured to operate in the DS3/E3 Mode, then the DS3/E3 Framer block can be configured to output the outbound DS3/E3 data (via the DS3/E3/STS_1_DATA_OUT and DS3/E3/STS_1_NEG_OUT output pins) upon either the rising or falling edge of DS3/E3/STS_1_CLOCK_OUT.
- b. If a given channel is configured to operate in the STS-1/STM-0 Mode, then the Transmit STS-1 TOH Processor block will be operating in the Single-Rail Mode (e.g., the Transmit STS-1 TOH Processor block will output all outbound STS-1/STM-0 data via the DS3/E3/STS_1_DATA_OUT output pin. No data will be output via the DS3/E3/STS_1_NEG_OUT output pin).
- c. Further, if a given channel is configured to operate in the STS-1/STM-0 Mode, then the Transmit STS-1 TOH Processor block can ONLY be configured to output the outbound STS-1/STM-0 data (via the DS3/E3/STS_1_DATA_OUT pin) upon the rising edge of DS3/E3/STS_1_CLOCK_OUT.

The Timing Diagram for the Egress DS3/E3/STS-1 Interface is presented below in **Figure 19**.

FIGURE 19. WAVEFORMS OF THE DS3/E3/STS-1 SIGNALS THAT ARE OUTPUT FROM THE DS3/E3/STS-1 LIU INTERFACE (IN THE RECEIVE/EGRESS DIRECTION)

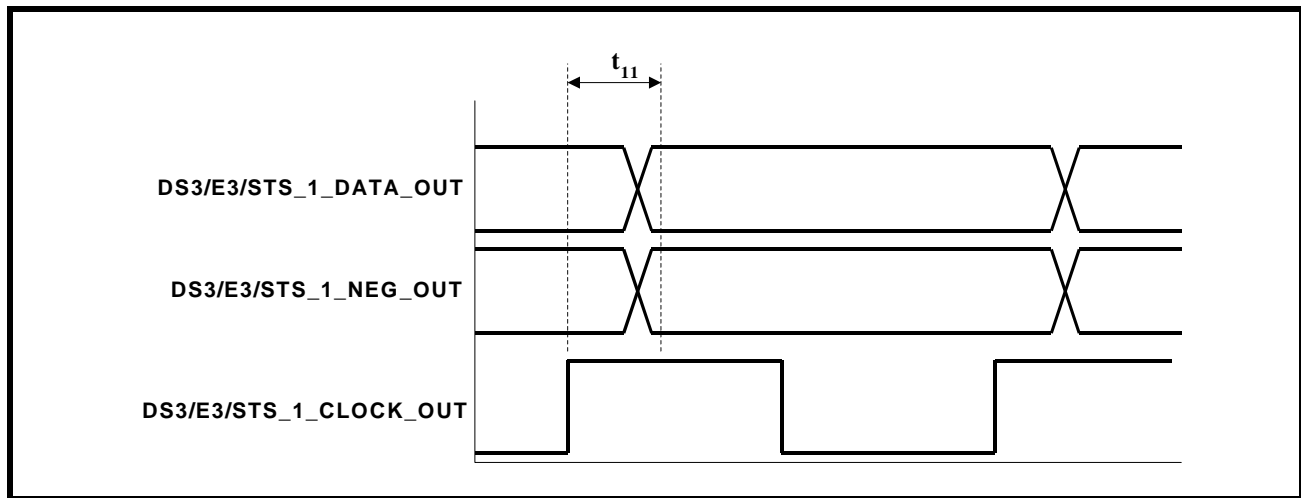

NOTE: The value for t_{11} is presented in **Table 12**, **Table 13** and **Table 14**.

4.5 Egress Timing for DS3/E3 Applications

Table 12 presents information on the Timing Parameters for the DS3/E3/STS-1 LIU Interface Signals (in the Egress Direction) for DS3/E3 Applications and when the DS3/E3 Framer block has been configured to output the outbound DS3/E3 data (via the DS3/E3/STS_1_DATA_OUT and DS3/E3/STS_1_NEG_OUT signal upon the rising edge of DS3/E3/STS_1_CLOCK_OUT.

TABLE 12: TIMING INFORMATION FOR THE EGRESS DS3/E3/STS-1 LIU INTERFACE FOR DS3/E3 APPLICATIONS AND WHEN THE DS3/E3 FRAMER BLOCK HAS BEEN CONFIGURED TO OUTPUT THE OUTBOUND DS3/E3 DATA (VIA THE DS3/E3/STS_1_DATA_OUT AND DS3/E3/STS_1_NEG_OUT OUTPUT PINS) UPON THE RISING EDGE OF DS3/E3/STS_1_CLOCK_OUT

SYMBOL	DESCRIPTION	MIN.	TYP.	MAX.
t_{11}	Rising edge of DS3/E3/STS_1_CLK_OUT to DS3/E3/STS_1_DATA_OUT & DS3/E3/STS_1_NEG_OUT output delay	0ns		4ns

Table 13 presents information on the Timing Parameters for the DS3/E3/STS-1 LIU Interface Signal (in the Egress Direction) for DS3/E3 Applications and when the DS3/E3 Framer block has been configured to output the outbound DS3/E3 data (via the DS3/E3/STS_1_DATA_OUT and DS3/E3/STS_1_NEG_OUT signals upon the falling edge of DS3/E3/STS_1_CLOCK_OUT.

TABLE 13: TIMING INFORMATION FOR THE EGRESS DS3/E3/STS-1 LIU INTERFACE FOR DS3/E3 APPLICATIONS AND WHEN THE DS3/E3 FRAMER BLOCK HAS BEEN CONFIGURED TO OUTPUT THE OUTBOUND DS3/E3 DATA (VIA THE DS3/E3/STS_1_DATA_OUT AND DS3/E3/STS_1_NEG_OUT OUTPUT PINS) UPON THE FALLING EDGE OF DS3/E3/STS_1_CLOCK_OUT

SYMBOL	DESCRIPTION	MIN.	TYP.	MAX.
t_{11}	Rising edge of DS3/E3/STS_1_CLK_OUT to DS3/E3/STS_1_DATA_OUT & DS3/E3/STS_1_NEG_OUT output delay	0ns		4ns

4.6 Egress Timing for STS-1/STM-0 Applications

Table 14 presents information on the Timing parameters for the DS3/E3/STS-1 LIU Interface Signals (in the Egress Direction) for STS-1/STM-0 Applications.

TABLE 14: TIMING INFORMATION FOR THE EGRESS DS3/E3/STS-1 LIU INTERFACE FOR STS-1/STM-0 APPLICATIONS

SYMBOL	DESCRIPTION	MIN.	TYP.	MAX.
t_{11}	Rising edge of DS3/E3/STS_1_CLK_OUT to DS3/E3/STS_1_DATA_OUT output delay	0ns		3ns

5.0 STS-3/STM-1 TELECOM BUS INTERFACE TIMING INFORMATION

5.1 STS-3/STM-1 Telecom Bus Interface Timing Information

This section presents the timing requirements for the STS-3/STM-1 Telecom Bus Interface. In particular this section indicates the following.

- a. Identifies which edge of RxD_CLK in which the RxD_D[7:0], RxD_PL, RxD_C1J1, RxD_ALARM and RxD_DP output pins are updated on.
- b. The clock to output delays (from the rising edge of RxD_CLK to the instant that the RxD_D[7:0], RxD_PL, RxD_C1J1, RxD_ALARM and RxD_DP output pins are updated).
- c. Identifies which edge of TxA_CLK that the TxA_D[7:0], TxA_PL, TxA_C1J1 and TxA_DP input pins are sampled on.
- d. The set-up time requirements (from an update in the TxA_D[7:0], TxA_PL, TxA_C1J1, TxA_ALARM and TxA_DP input signals to the rising edge of TxA_CLK).
- e. The hold-time requirements (from the rising edge of TxA_CLK to a change in the TxA_D[7:0], TxA_PL, TxA_C1J1, TxA_ALARM and TxA_DP input signals)

In contrast to the names that are given to the Transmit and Receive STS-3/STM-1 Telecom Bus Interface, the Transmit STS-3/STM-1 Telecom Bus interface will have the responsibility of receiving (in lieu of transmitting) STS-3/STM-1 data from some remote entity over a Telecom Bus Interface that is clocked at 19.44MHz. Likewise, the Receive STS-3/STM-1 Telecom Bus Interface will have the responsibility of transmitting (in lieu of receiving) STS-3/STM-1 data to some remote entity over a Telecom Bus Interface that is also clocked at 19.44MHz.

5.2 The Receive STS-3/STM-1 Telecom Bus Interface Timing

In the Receive STS-3/STM-1 Telecom Bus Interface, all of the signals (which are output via this Bus Interface) are updated upon the rising edge of RxD_CLK (19.44MHz clock signal).

Figure 20 and Figure 21 presents an illustration of the waveforms of the signals that will be output via the Receive STS-3/STM-1 Telecom Bus Interface along with the timing parameter (t_{12}).

FIGURE 20. WAVEFORMS OF THE SIGNALS THAT ARE OUTPUT VIA THE RECEIVE STS-3/STM-1 TELECOM BUS INTERFACE

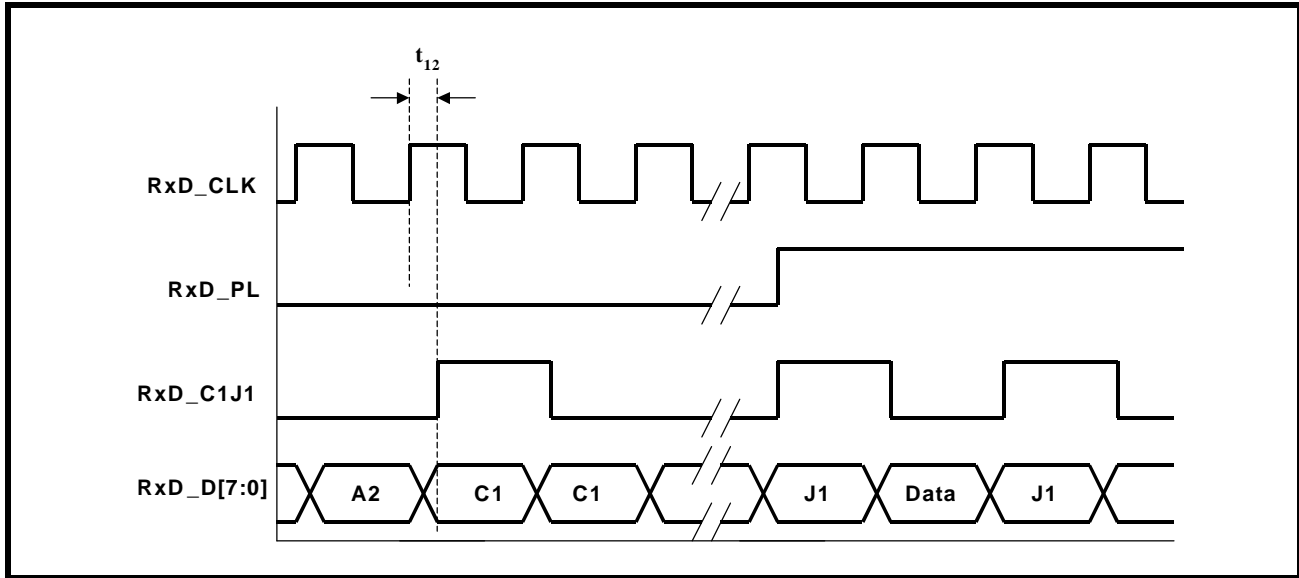

NOTE: The value for t_{12} can be found in Table 15.

Table 15 presents information on the Timing parameters for the Receive STS-3/STM-1 Telecom Bus Interface.

TABLE 15: TIMING INFORMATION FOR THE RECEIVE STS-3/STM-1 TELECOM BUS INTERFACE

SYMBOL	DESCRIPTION	MIN.	TYP.	MAX.
t_{12}	Rising edge of RxD_CLK to updates in RxD_D[7:0], RxD_PL, RxD_C1J1, RxD_ALARM and RxD_DP	0ns		3ns

5.3 The Transmit STS-3/STM-1 Telecom Bus Interface Timing

In the Transmit STS-3/STM-1 Telecom Bus Interface, all of the signals (which are input via this Bus Interface) are sampled upon the rising edge of TxA_CLK (19.44MHz clock signal).

Figure 21 presents an illustration of the waveforms and the timing parameters (t_{13} and t_{14}) of the signals that will be received by the Transmit STS-3/STM-1 Telecom Bus Interface.

FIGURE 21. WAVEFORMS OF THE SIGNALS THAT ARE INPUT VIA THE TRANSMIT STS-3/STM-1 TELECOM BUS INTERFACE

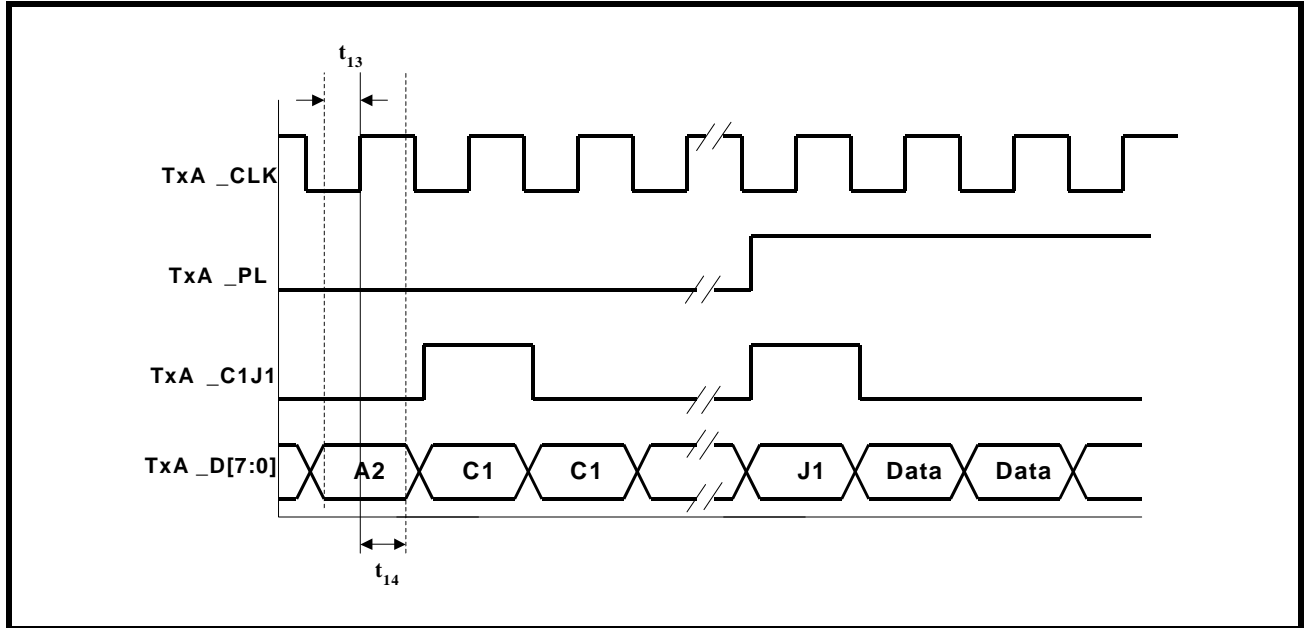

NOTE: The value for t_{13} and t_{14} can be found in **Table 16**.

Table 16 presents information on the Timing parameters for the Transmit STS-3/STM-1 Telecom Bus Interface.

TABLE 16: TIMING INFORMATION FOR THE TRANSMIT STS-3/STM-1 TELECOM BUS INTERFACE

SYMBOL	DESCRIPTION	MIN.	TYP.	MAX.
t_{13}	TxA_D[7:0], TxA_PL, TxA_C1J1, TxA_ALARM and TxA_DP to rising edge of TxA_CLK set-up time requirements	10ns		
t_{14}	Rising edge of TxA_CLK to TxA_D[7:0], TxA_PL, TxA_C1J1, TxA_ALARM and TxA_DP hold time requirements	0 ns		

6.0 TRANSMIT TOH OVERHEAD INPUT PORT

6.1 Transmit TOH Overhead Input Port

The Transmit TOH Overhead Input Port permits the user to insert his/her own value for the TOH bytes into the outbound STS-12/STM-4 data-stream. The user should note that the TxTOHIns and the TxTOH input pins are sampled (by the Transmit TOH Overhead Input Port) upon the rising edge of TxTOHClk. All of the remaining

signals (e.g., TxTOHFrame and TxTOHEnable) are updated upon the falling edge of TxTOHClk. The timing waveform and information for the Transmit TOH Overhead Input Port is presented below.

FIGURE 22. TIMING WAVEFORM OF THE TRANSMIT TOH OVERHEAD INPUT PORT

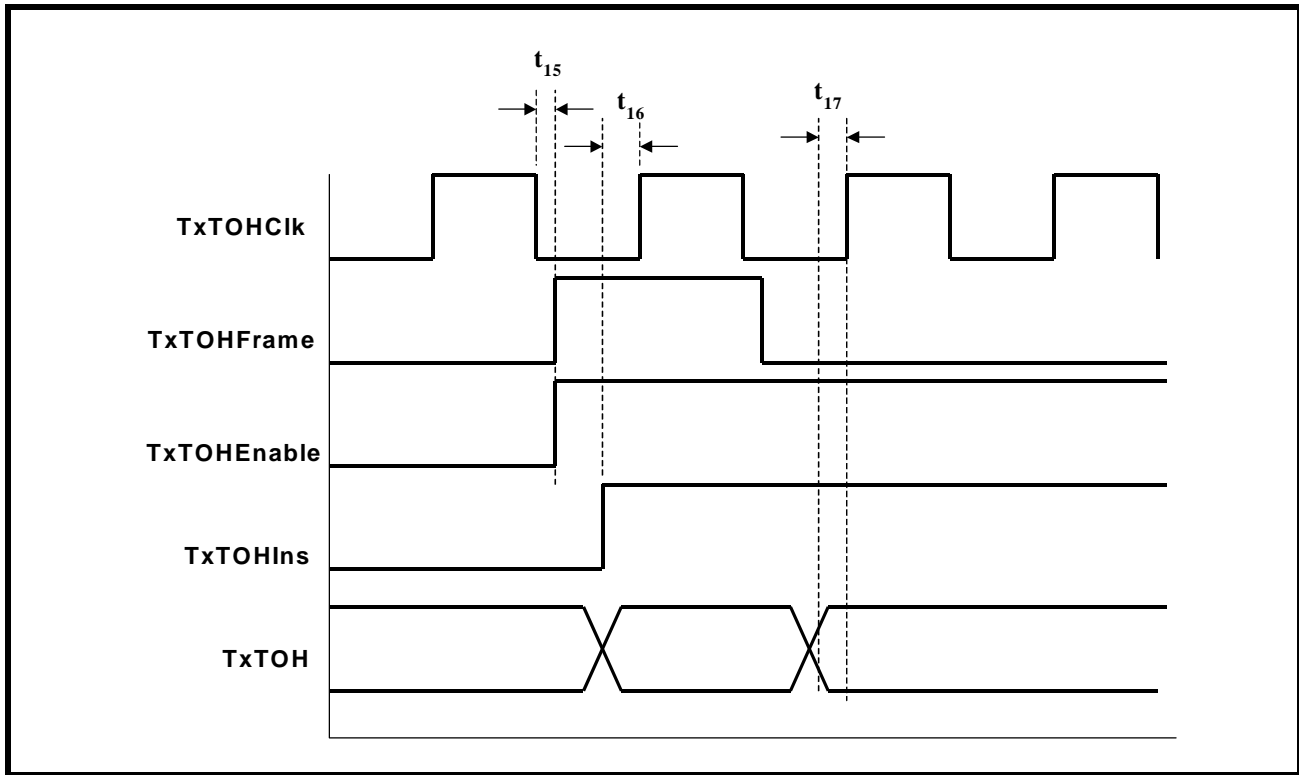

NOTE: The values for t_{15} , t_{16} and t_{17} can be found in [Table 17](#).

TABLE 17: TIMING INFORMATION FOR THE TRANSMIT TOH OVERHEAD INPUT PORT

SYMBOL	DESCRIPTION	MIN.	TYP.	MAX.
t_{15}	Falling edge of TxTOHClk to rising edge of TxTOHFrame and TxTOHEnable	-0.5ns		0.5ns
t_{16}	TxTOHIns to rising edge of TxTOHClk set-up time	12ns		
t_{17}	TxTOH Data to rising edge of TxTOHClk set-up time	11ns		

7.0 TRANSMIT POH OVERHEAD INPUT PORT

7.1 Transmit POH Overhead Input Port

The Transmit POH Overhead Input Port permits the user to insert his/her own value for the POH bytes into either the outbound STS-1 SPE data-stream (which is output via the Transmit STS-12/STM-4 data-stream or via the outbound STS-1 SPE data-stream (which is output via the Transmit STS-1 data-stream). The user should note that the TxPOHIns and the TxPOH input pins are sampled (by the Transmit POH Overhead Input Port) upon the rising edge of TxPOHClk. All of the remaining signals (e.g., TxPOHFrame and TxPOHEnable) are updated upon the falling edge of TxPOHClk. The timing waveform and information for the Transmit POH Overhead Input Port is presented below.

FIGURE 23. TIMING WAVEFORM OF THE TRANSMIT POH OVERHEAD INPUT PORT



NOTE: The values for t_{18} , t_{19} and t_{20} can be found in [Table 18](#).

TABLE 18: TIMING INFORMATION FOR THE TRANSMIT POH OVERHEAD INPUT PORT

SYMBOL	DESCRIPTION	MIN.	TYP.	MAX.
t_{18}	Falling edge of TxPOHClk to rising edge of TxPOHFrame and TxPOHEnable	-1.5ns		3ns
t_{19}	TxPOHIns to rising edge of TxPOHClk set-up time	15ns		
t_{20}	TxPOH Data to rising edge of TxPOHClk set-up time	14ns		

8.0 TRANSMIT ORDERWIRE (E1, F1, E2) BYTE OVERHEAD INPUT PORT

8.1 Transmit E1, F1, E2 (Order-wire) Byte Overhead Input Port

The Transmit Order-wire Byte Overhead Input Port provides a dedicated port for the user to insert his/her own value for the E1, F1 and E2 bytes within the outbound STS-12/STM-4 data-stream. The user should note that the TxE1F1E2 input pin is sampled (by the Transmit Order-wire Byte Overhead Input Port) upon the rising edge of TxTOHClk. All of the remaining signals (e.g., TxE1F1E2Enable, TxE1F1E2Frame) are updated upon the falling edge of TxTOHClk. The timing waveform and information for the Transmit Order-wire Byte Overhead Input Port is presented below.

FIGURE 24. TIMING WAVEFORM OF THE TRANSMIT ORDER-WIRE BYTE OVERHEAD INPUT PORT

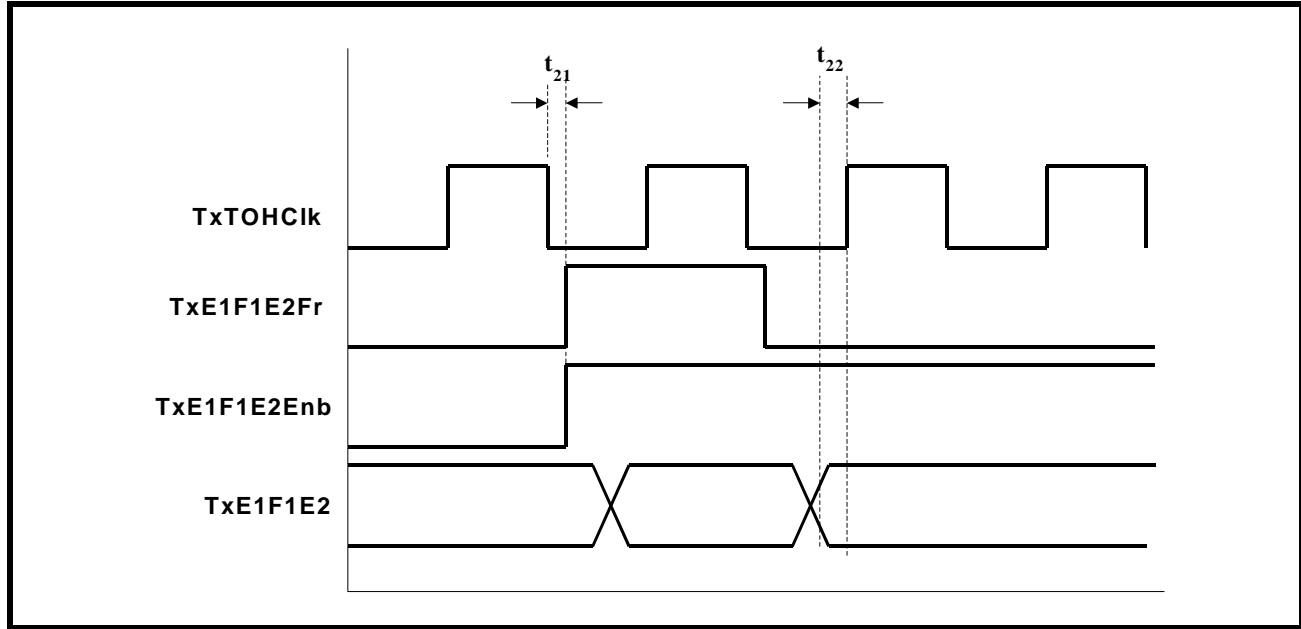

NOTE: The values for t_{21} and t_{22} can be found in [Table 19](#).

TABLE 19: TIMING INFORMATION FOR THE TRANSMIT ORDER-WIRE BYTE OVERHEAD INPUT PORT

SYMBOL	DESCRIPTION	MIN.	TYP.	MAX.
t_{21}	Falling edge of TxTOHCik to rising edge of TxE1F1F2Enable and TxE1F1F2Frame	-0.5ns		0.5ns
t_{22}	TxE1F1F2 Data to rising edge of TxTOHCik set-up time	11ns		

9.0 TRANSMIT SECTION DCC INSERTION INPUT PORT

9.1 Transmit Section DCC Insertion Input Port

The Transmit Section DCC Insertion Input Port provides a dedicated port for the user to insert his/her own value for the D1, D2 and D3 bytes within the outbound STS-12/STM-4 data-stream. The user should note that the TxSDCC input pin is sampled (by the Transmit Section DCC Insertion Input Port) upon the rising edge of

TxTOHCk. The TxSDCCEnable output signal is updated upon the falling edge of TxTOHCk. The timing waveform and information for the Transmit Section DCC Insertion Input Port is presented below.

FIGURE 25. TIMING WAVEFORM OF THE TRANSMIT SECTION DCC OVERHEAD INSERTION PORT

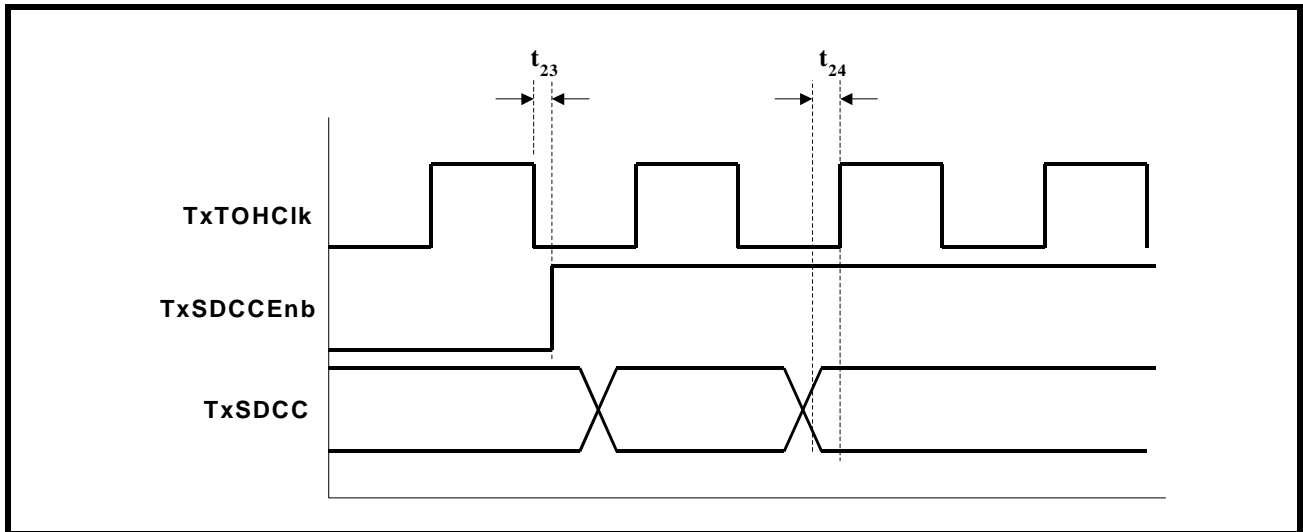

NOTE: The values for t_{23} and t_{24} can be found in [Table 20](#).

TABLE 20: TIMING INFORMATION FOR THE TRANSMIT ORDER-WIRE BYTE OVERHEAD INPUT PORT

SYMBOL	DESCRIPTION	MIN.	TYP.	MAX.
t_{23}	Falling edge of TxTOHCk to rising edge of TxSDCCEnable	-0.5ns		0.5ns
t_{24}	TxSDCC Data to rising edge of TxTOHCk set-up time	12ns		

10.0 TRANSMIT LINE DCC INSERTION INPUT PORT

10.1 Transmit Line DCC Insertion Input Port

The Transmit Section DCC Insertion Input Port provides a dedicated port for the user to insert his/her own value for the D4 through D12 bytes within the outbound STS-12/STM-4 data-stream. The user should note that the TxLDCC input pin is sampled (by the Transmit Section DCC Insertion Input Port) upon the rising edge

SONET/SDH OC-12 TO 12XDS3/E3 MAPPER

of TxTOHClk. The TxLDCCEnable output signal is updated upon the falling edge of TxTOHClk. The timing waveform and information for the Transmit Line DCC Insertion Input Port is presented below.

FIGURE 26. TIMING WAVEFORM OF THE TRANSMIT LINE DCC INSERTION INPUT PORT

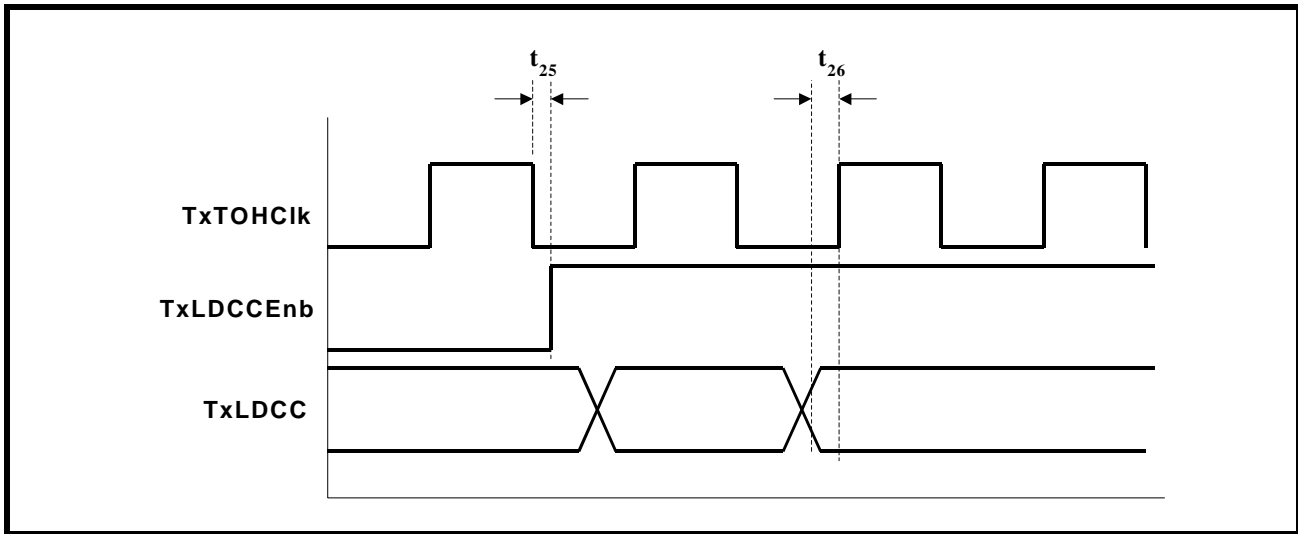

NOTE: The values for t_{25} and t_{26} can be found in [Table 21](#).

TABLE 21: TIMING INFORMATION FOR THE TRANSMIT LINE DCC INSERTION INPUT PORT

SYMBOL	DESCRIPTION	MIN.	TYP.	MAX.
t_{25}	Falling edge of TxTOHClk to rising edge of TxLDCCEnable	-0.5ns		0.5ns
t_{26}	TxLDCC Data to rising edge of TxTOHClk set-up time	11ns		

11.0 RECEIVE TOH OVERHEAD OUTPUT PORT

11.1 Receive TOH Overhead Output Port

The Receive TOH Overhead Output port permits the user to extract out the values of the TOH bytes within the incoming STS-12/STM-4 data-stream. All of the Receive TOH Overhead Output port signals are updated upon

the falling edge of RxTOHCik. The timing waveform and information for the Receive TOH Overhead Output Port is presented below.

FIGURE 27. TIMING WAVEFORM OF THE RECEIVE TOH OVERHEAD OUTPUT PORT

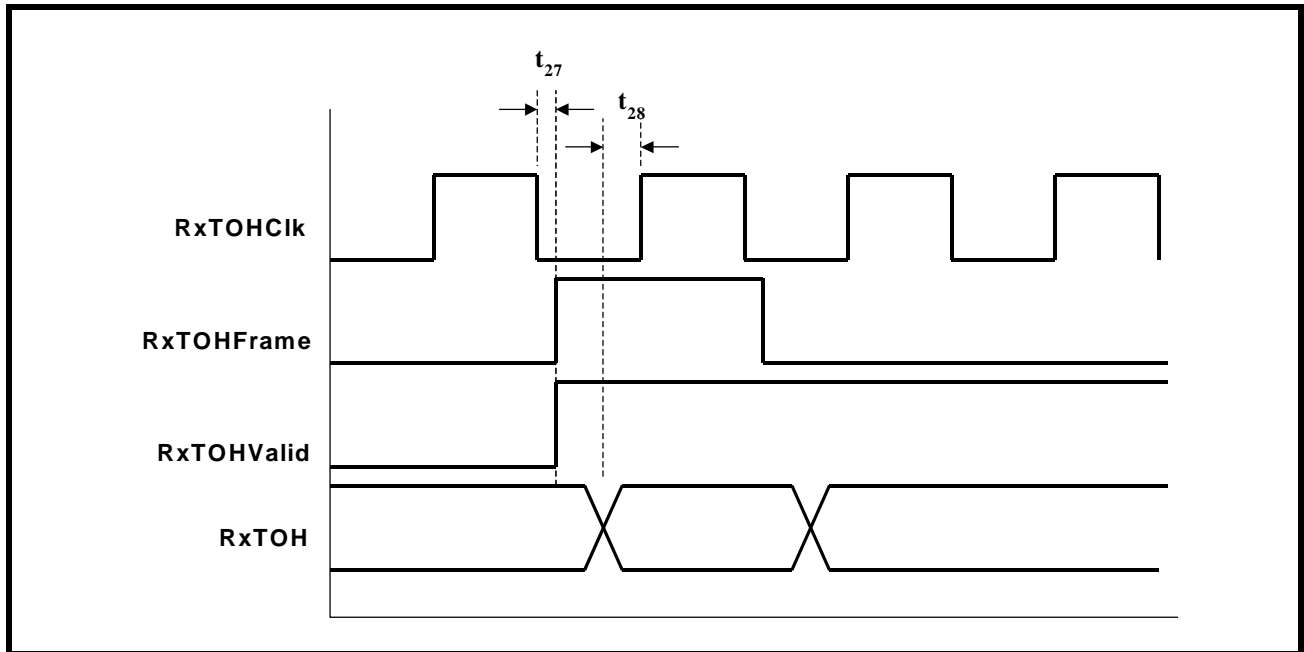

NOTE: The values for t_{27} and t_{28} can be found in [Table 22](#).

TABLE 22: TIMING INFORMATION FOR THE RECEIVE TOH OVERHEAD OUTPUT PORT

SYMBOL	DESCRIPTION	MIN.	TYP.	MAX.
t_{27}	Falling edge of RxTOHCik to rising edge of RxTOHFrame and RxTOHValid	-0.2ns		0.4ns
t_{28}	Falling edge of RxTOHCik to RxTOH output delay	0.2ns		0.1ns

12.0 RECEIVE POH OVERHEAD OUTPUT PORT

12.1 Receive POH Overhead Output Port

The Receive POH Overhead Output port permits the user to extract out the values of the POH bytes within the incoming STS-12/STM-4 data-stream. All of the Receive POH Overhead Output port signals are updated upon the falling edge of RxPOHCik. The timing waveform and information for the Receive POH Overhead Output Port is presented below.

FIGURE 28. TIMING WAVEFORM OF THE RECEIVE POH OVERHEAD OUTPUT PORT

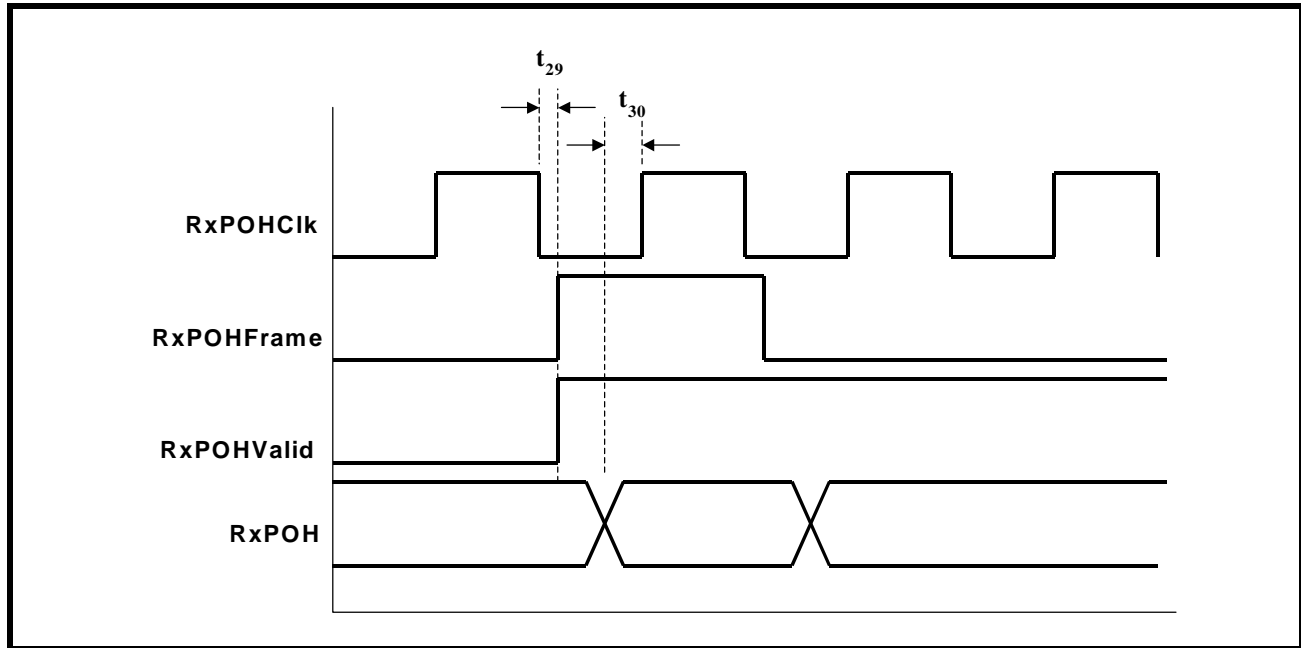

NOTE: The values for t_{29} and t_{30} can be found in [Table 23](#).

TABLE 23: TIMING INFORMATION FOR THE RECEIVE POH OVERHEAD OUTPUT PORT

SYMBOL	DESCRIPTION	MIN.	TYP.	MAX.
t_{29}	Falling edge of RxPOHClk to rising edge of RxPOHFrame and RxPOHValid	0.2ns		3ns
t_{30}	Falling edge of RxPOHClk to RxPOH output delay	0.2ns		1.5ns

13.0 RECEIVE ORDERWIRE (E1, F1, E2) BYTES OVERHEAD OUTPUT PORT

13.1 Receive E1, F1, E2 (Order-Wire) Byte Overhead Output Port

The Receive Order-wire Byte Overhead output port provides a dedicated port for the user to extract out the Order-wire (e.g., the E1, F1 and E2) bytes from that within the incoming STS-12/STM-4 data-stream. The user

should note that all of the output signals (of this port) are updated upon the falling edge of RxTOHCik. The timing waveform and information for the Receive Order-wire Byte Overhead output port is presented below.

FIGURE 29. TIMING WAVEFORM OF THE RECEIVE ORDER-WIRE BYTE OVERHEAD OUTPUT PORT

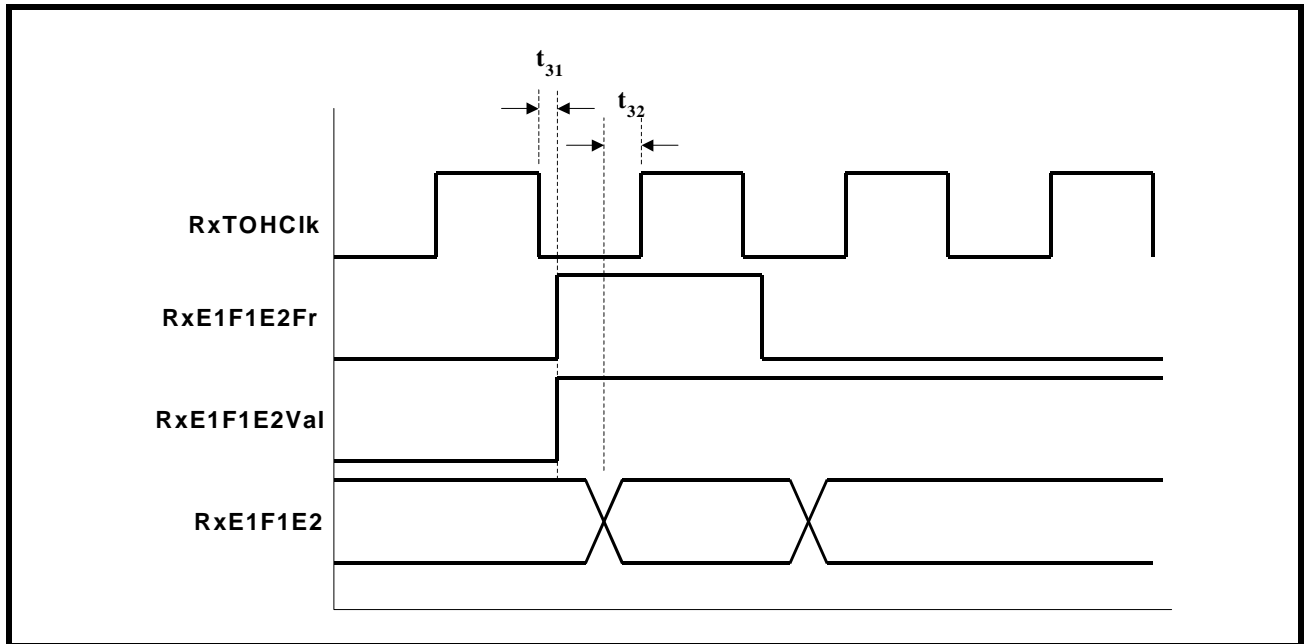

NOTE: The values for t_{31} and t_{32} can be found in [Table 24](#).

TABLE 24: TIMING INFORMATION FOR THE RECEIVE ORDER-WIRE BYTE OVERHEAD OUTPUT PORT

SYMBOL	DESCRIPTION	MIN.	TYP.	MAX.
t_{31}	Falling edge of RxTOHCik to rising edge of RxE1F1E2Frame and RxE1F1E2Valid	-0.2ns		0.4ns
t_{32}	Falling edge of RxTOHCik to RxE1F1E2 output delay	0.1ns		0.3ns

14.0 RECEIVE SECTION DCC EXTRACTION OUTPUT PORT

14.1 Receive Section DCC Output Port

The Receive Section DCC output port provides a dedicated port for the user to extract out the Section DCC (e.g., D1, D2 and D3) bytes from that within the incoming STS-12/STM-4 data-stream. The user should note that all of the output signals (of this port) are updated upon the falling edge of RxTOHCik. The timing waveform and information for the Receive Section DCC output port is presented below.

FIGURE 30. TIMING WAVEFORM OF THE RECEIVE SECTION DCC OUTPUT PORT

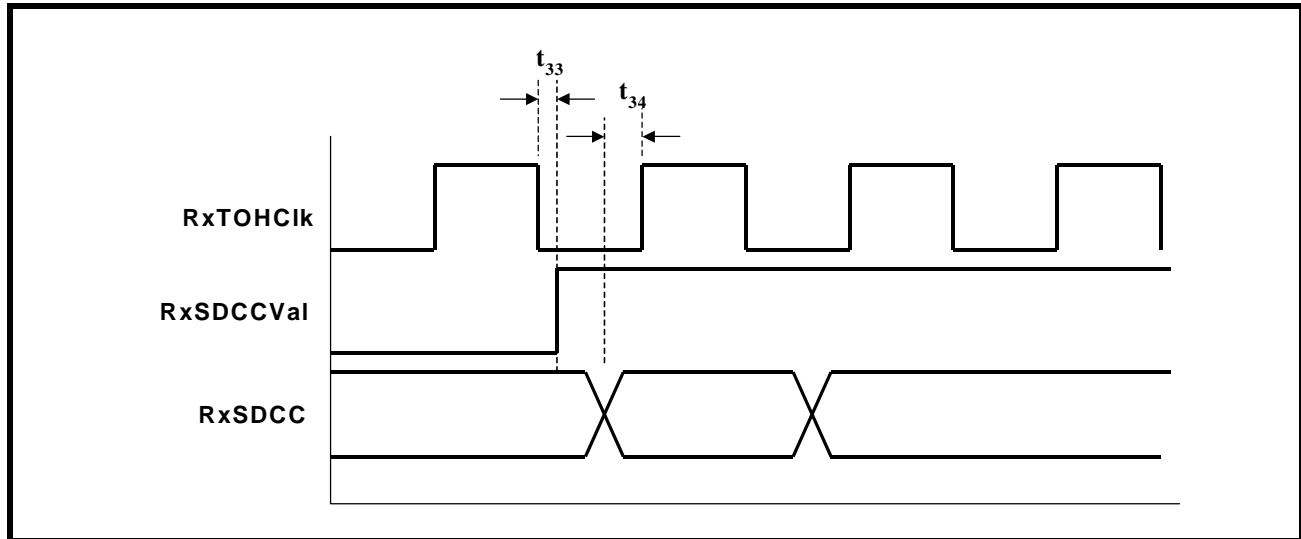

NOTE: The values for t_{33} and t_{34} can be found in [Table 25](#).

TABLE 25: TIMING INFORMATION FOR THE RECEIVE SECTION DCC OUTPUT PORT

SYMBOL	DESCRIPTION	MIN.	TYP.	MAX.
t_{33}	Falling edge of RxTOHClk to rising edge of RxSDCCVal	0ns		0.5ns
t_{34}	Falling edge of RxTOHClk to RxSDCC output delay	0.1ns		0.5ns

15.0 RECEIVE LINE DCC EXTRACTION OUTPUT PORT

15.1 Receive Line DCC Output Port

The Receive Line DCC output port provides a dedicated port for the user to extract out the Line DCC (e.g., D4 through D12) bytes from that within the incoming STS-12/STM-4 data-stream. The user should note that all of the output signals (of this port) are updated upon the falling edge of RxTOHClk. The timing waveform and information for the Receive Line DCC output port is presented below.

FIGURE 31. TIMING WAVEFORM OF THE RECEIVE LINE DCC OUTPUT PORT

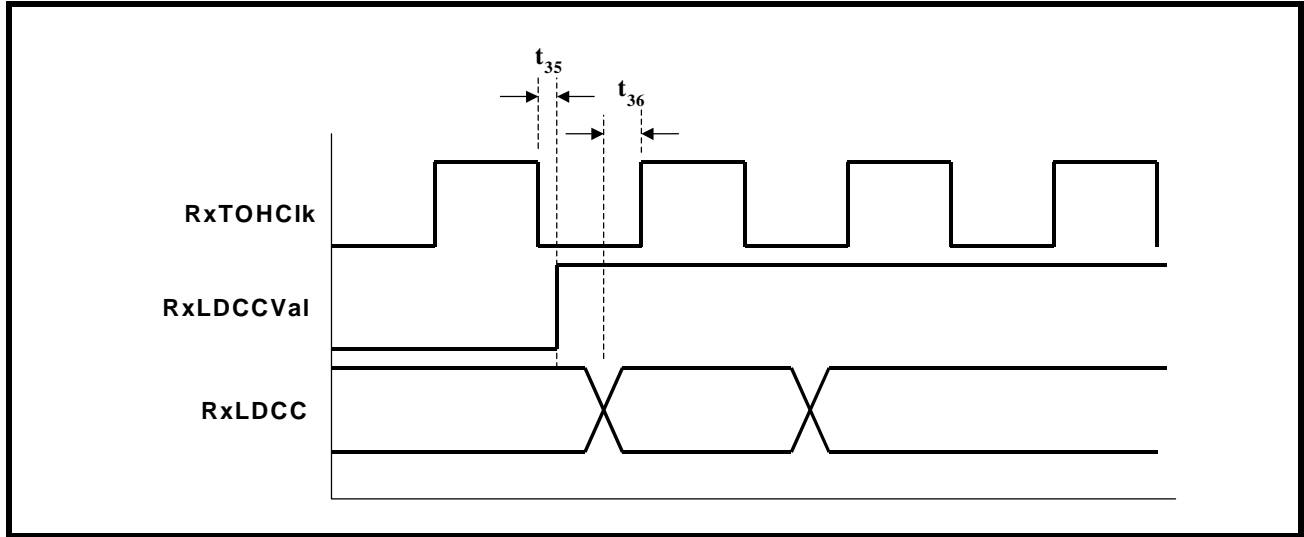

NOTE: The values for t_{35} and t_{36} can be found in [Table 26](#).

TABLE 26: TIMING INFORMATION FOR THE RECEIVE LINE DCC OUTPUT PORT

SYMBOL	DESCRIPTION	MIN.	TYP.	MAX.
t_{35}	Falling edge of RxTOHClk to rising edge of RxLDCCValid	-0.2ns		0.1ns
t_{36}	Falling edge of RxTOHClk to RxLDCC output delay	0.1ns		0.4ns

ORDERING INFORMATION

PART NUMBER	PACKAGE	OPERATING TEMPERATURE RANGE
XRT94L43IB	516 PBGA	-40°C to +85°C

PACKAGE DIMENSIONS

**516 Ball Plastic Ball Grid Array
(35 x 35 mm PBGA)
Rev. 1.0 (Bottom View)**

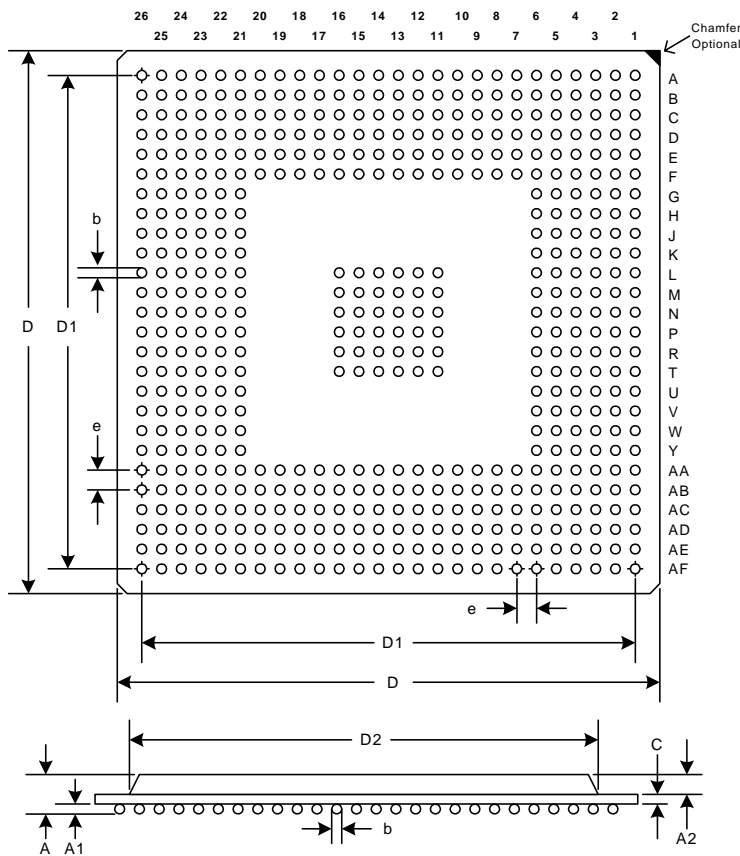

Symbol	Inches		Millimeters	
	MIN	MAX	MIN	MAX
A	0.075	0.106	1.90	2.70
A1	0.020	0.028	0.50	0.70
A2	0.039	0.051	1.00	1.30
b	0.024	0.035	0.60	0.90
C	0.016	0.028	0.40	0.70
D	1.370	1.386	34.80	35.20
D1	1.250BSC		31.75BSC	
D2	1.177	1.185	29.90	30.10
e	0.050BSC		1.27BSC	

Note: The control dimension is the millimeter column

REVISION HISTORY

REVISION #	DATE	DESCRIPTION
P1.0.0	July 2002	Short form.
P1.0.1	July 2002	Added pin out and Register tables.
P1.0.2	August 2002	Added descriptive sections.
P1.0.3	August 2002	Added more description to sections.
P1.0.4	September 2002	Corrected Direct Addresses by adding 100Hex to each.
P1.0.4	December 2002	Added SDH Register tables and Direct addressing pin out. Made minor edits to text and broke data sheet into three books, (Description and pin outs, Sonet Registers and SDH Registers.
P1.0.5	May 2002	Added electrical characteristics.
1.0.0	June 2004	Final edits, release to production
1.0.1	July 2006	Made edits to pin descriptions
1.0.2	November 2006	Added/changed block diagrams and features.

NOTICE

EXAR Corporation reserves the right to make changes to the products contained in this publication in order to improve design, performance or reliability. EXAR Corporation assumes no responsibility for the use of any circuits described herein, conveys no license under any patent or other right, and makes no representation that the circuits are free of patent infringement. Charts and schedules contained here in are only for illustration purposes and may vary depending upon a user's specific application. While the information in this publication has been carefully checked; no responsibility, however, is assumed for inaccuracies.

EXAR Corporation does not recommend the use of any of its products in life support applications where the failure or malfunction of the product can reasonably be expected to cause failure of the life support system or to significantly affect its safety or effectiveness. Products are not authorized for use in such applications unless EXAR Corporation receives, in writing, assurances to its satisfaction that: (a) the risk of injury or damage has been minimized; (b) the user assumes all such risks; (c) potential liability of EXAR Corporation is adequately protected under the circumstances.

Copyright 2006 EXAR Corporation

Datasheet November 2006.

Reproduction, in part or whole, without the prior written consent of EXAR Corporation is prohibited.

Looking for pricing, stock, or lifecycle information?

Click below to explore more details on WIN SOURCE:

 [View XRT94L43IB-F on WIN SOURCE](#)

 [MaxLinear Inc Information](#)

Optimize Your Supply Chain with WIN SOURCE Solutions

-  Global Sourcing Solution
-  Obsolete Management
-  Cost Control Management
-  Shortage Management
-  Alternative Solution
-  Excess Inventory Management