



**THE DATASHEET OF  
XCS40-3PQ208C**





# Spartan and Spartan-XL FPGA Families Data Sheet

DS060 (v2.0) March 1, 2013

## Product Specification

### Introduction

The Spartan® and the Spartan-XL FPGA families are a high-volume production FPGA solution that delivers all the key requirements for ASIC replacement up to 40,000 gates. These requirements include high performance, on-chip RAM, core solutions and prices that, in high volume, approach and in many cases are equivalent to mask programmed ASIC devices.

By streamlining the Spartan series feature set, leveraging advanced process technologies and focusing on total cost management, the Spartan series delivers the key features required by ASIC and other high-volume logic users while avoiding the initial cost, long development cycles and inherent risk of conventional ASICs. The Spartan and Spartan-XL families in the Spartan series have ten members, as shown in [Table 1](#).

### Spartan/Spartan-XL FPGA Features

Note: The Spartan series devices described in this data sheet include the 5V Spartan family and the 3.3V Spartan-XL family. See the separate data sheets for more advanced members for the Spartan Series.

- First ASIC replacement FPGA for high-volume production with on-chip RAM
- Density up to 1862 logic cells or 40,000 system gates
- Streamlined feature set based on XC4000 architecture
- System performance beyond 80 MHz
- Broad set of AllianceCORE and LogiCORE™ predefined solutions available
- Unlimited reprogrammability
- Low cost

- System level features
  - Available in both 5V and 3.3V versions
  - On-chip SelectRAM™ memory
  - Fully PCI compliant
  - Full readback capability for program verification and internal node observability
  - Dedicated high-speed carry logic
  - Internal 3-state bus capability
  - Eight global low-skew clock or signal networks
  - IEEE 1149.1-compatible Boundary Scan logic
  - Low cost plastic packages available in all densities
  - Footprint compatibility in common packages
- Fully supported by powerful Xilinx ISE® Classics development system
  - Fully automatic mapping, placement and routing

### Additional Spartan-XL Family Features

- 3.3V supply for low power with 5V tolerant I/Os
- Power down input
- Higher performance
- Faster carry logic
- More flexible high-speed clock network
- Latch capability in Configurable Logic Blocks
- Input fast capture latch
- Optional MUX or 2-input function generator on outputs
- 12 mA or 24 mA output drive
- 5V and 3.3V PCI compliant
- Enhanced Boundary Scan
- Express Mode configuration
- 

Table 1: Spartan and Spartan-XL Field Programmable Gate Arrays

Device	Logic Cells	Max System Gates	Typical Gate Range (Logic and RAM) <sup>(1)</sup>	CLB Matrix	Total CLBs	No. of Flip-flops	Max. Avail. User I/O	Total Distributed RAM Bits
XCS05 and XCS05XL	238	5,000	2,000-5,000	10 x 10	100	360	77	3,200
XCS10 and XCS10XL	466	10,000	3,000-10,000	14 x 14	196	616	112	6,272
XCS20 and XCS20XL	950	20,000	7,000-20,000	20 x 20	400	1,120	160	12,800
XCS30 and XCS30XL	1368	30,000	10,000-30,000	24 x 24	576	1,536	192	18,432
XCS40 and XCS40XL	1862	40,000	13,000-40,000	28 x 28	784	2,016	205 <sup>(2)</sup>	25,088

#### Notes:

1. Max values of Typical Gate Range include 20-30% of CLBs used as RAM.
2. XCS40XL provided 224 max I/O in CS280 package discontinued by [PDN2004-01](#).

## General Overview

Spartan series FPGAs are implemented with a regular, flexible, programmable architecture of Configurable Logic Blocks (CLBs), interconnected by a powerful hierarchy of versatile routing resources (routing channels), and surrounded by a perimeter of programmable Input/Output Blocks (IOBs), as seen in **Figure 1**. They have generous routing resources to accommodate the most complex interconnect patterns.

The devices are customized by loading configuration data into internal static memory cells. Re-programming is possible an unlimited number of times. The values stored in these

memory cells determine the logic functions and interconnections implemented in the FPGA. The FPGA can either actively read its configuration data from an external serial PROM (Master Serial mode), or the configuration data can be written into the FPGA from an external device (Slave Serial mode).

Spartan series FPGAs can be used where hardware must be adapted to different user applications. FPGAs are ideal for shortening design and development cycles, and also offer a cost-effective solution for production rates well beyond 50,000 systems per month.



DS060\_01\_081100

Figure 1: Basic FPGA Block Diagram

Spartan and Spartan-XL devices provide system clock rates exceeding 80 MHz and internal performance in excess of 150 MHz. In addition to the conventional benefit of high volume programmable logic solutions, Spartan series FPGAs also offer on-chip edge-triggered single-port and dual-port RAM, clock enables on all flip-flops, fast carry logic, and many other features.

The Spartan/XL families leverage the highly successful XC4000 architecture with many of that family's features and benefits. Technology advancements have been derived from the XC4000XLA process developments.

## Logic Functional Description

The Spartan series uses a standard FPGA structure as shown in [Figure 1, page 2](#). The FPGA consists of an array of configurable logic blocks (CLBs) placed in a matrix of routing channels. The input and output of signals is achieved through a set of input/output blocks (IOBs) forming a ring around the CLBs and routing channels.

- CLBs provide the functional elements for implementing the user's logic.
- IOBs provide the interface between the package pins and internal signal lines.
- Routing channels provide paths to interconnect the inputs and outputs of the CLBs and IOBs.

The functionality of each circuit block is customized during configuration by programming internal static memory cells. The values stored in these memory cells determine the logic functions and interconnections implemented in the FPGA.

## Configurable Logic Blocks (CLBs)

The CLBs are used to implement most of the logic in an FPGA. The principal CLB elements are shown in the simplified block diagram in [Figure 2](#). There are three look-up tables (LUT) which are used as logic function generators, two flip-flops and two groups of signal steering multiplexers. There are also some more advanced features provided by the CLB which will be covered in the [Advanced Features Description, page 13](#).

### Function Generators

Two 16 x 1 memory look-up tables (F-LUT and G-LUT) are used to implement 4-input function generators, each offering unrestricted logic implementation of any Boolean function of up to four independent input signals (F1 to F4 or G1 to G4). Using memory look-up tables the propagation delay is independent of the function implemented.

A third 3-input function generator (H-LUT) can implement any Boolean function of its three inputs. Two of these inputs are controlled by programmable multiplexers (see box "A" of [Figure 2](#)). These inputs can come from the F-LUT or G-LUT outputs or from CLB inputs. The third input always comes from a CLB input. The CLB can, therefore, implement certain functions of up to nine inputs, like parity checking. The three LUTs in the CLB can also be combined to do any arbitrarily defined Boolean function of five inputs.



Figure 2: Spartan/XL Simplified CLB Logic Diagram (some features not shown)

A CLB can implement any of the following functions:

- Any function of up to four variables, plus any second function of up to four unrelated variables, plus any third function of up to three unrelated variables
- **Note:** When three separate functions are generated, one of the function outputs must be captured in a flip-flop internal to the CLB. Only two unregistered function generator outputs are available from the CLB.
- Any single function of five variables
- Any function of four variables together with some functions of six variables
- Some functions of up to nine variables.

Implementing wide functions in a single block reduces both the number of blocks required and the delay in the signal path, achieving both increased capacity and speed.

The versatility of the CLB function generators significantly improves system speed. In addition, the design-software tools can deal with each function generator independently. This flexibility improves cell usage.

### Flip-Flops

Each CLB contains two flip-flops that can be used to register (store) the function generator outputs. The flip-flops and function generators can also be used independently (see [Figure 2](#)). The CLB input DIN can be used as a direct input to either of the two flip-flops. H1 can also drive either flip-flop via the H-LUT with a slight additional delay.

The two flip-flops have common clock (CK), clock enable (EC) and set/reset (SR) inputs. Internally both flip-flops are also controlled by a global initialization signal (GSR) which is described in detail in [Global Signals: GSR and GTS, page 20](#).

### Latches (Spartan-XL Family Only)

The Spartan-XL family CLB storage elements can also be configured as latches. The two latches have common clock (K) and clock enable (EC) inputs. Functionality of the storage element is described in [Table 2](#).

Table 2: CLB Storage Element Functionality

Mode	CK	EC	SR	D	Q
Power-Up or GSR	X	X	X	X	SR
Flip-Flop Operation	X	X	1	X	SR
		1*	0*	D	D
	0	X	0*	X	Q
Latch Operation (Spartan-XL)	1	1*	0*	X	Q
	0	1*	0*	D	D
Both	X	0	0*	X	Q

**Legend:**

- X Don't care
-  Rising edge (clock not inverted).
- SR Set or Reset value. Reset is default.
- 0\* Input is Low or unconnected (default value)
- 1\* Input is High or unconnected (default value)

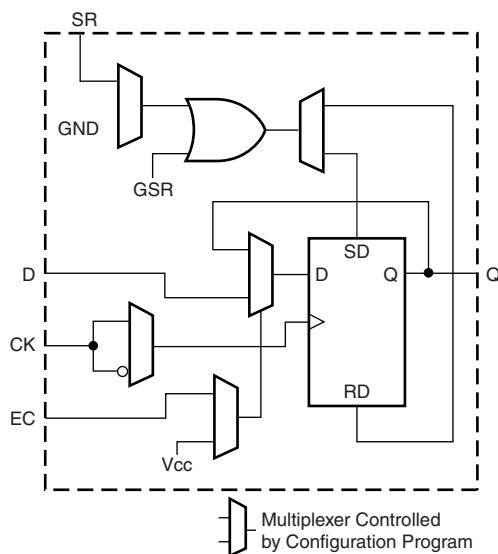

DS060\_03\_041901

Figure 3: CLB Flip-Flop Functional Block Diagram

**Clock Input**

Each flip-flop can be triggered on either the rising or falling clock edge. The CLB clock line is shared by both flip-flops. However, the clock is individually invertible for each flip-flop (see CK path in Figure 3). Any inverter placed on the clock line in the design is automatically absorbed into the CLB.

**Clock Enable**

The clock enable line (EC) is active High. The EC line is shared by both flip-flops in a CLB. If either one is left disconnected, the clock enable for that flip-flop defaults to the active state. EC is not invertible within the CLB. The clock enable is synchronous to the clock and must satisfy the setup and hold timing specified for the device.

**Set/Reset**

The set/reset line (SR) is an asynchronous active High control of the flip-flop. SR can be configured as either set or reset at each flip-flop. This configuration option determines the state in which each flip-flop becomes operational after configuration. It also determines the effect of a GSR pulse during normal operation, and the effect of a pulse on the SR line of the CLB. The SR line is shared by both flip-flops. If SR is not specified for a flip-flop the set/reset for that flip-flop defaults to the inactive state. SR is not invertible within the CLB.

**CLB Signal Flow Control**

In addition to the H-LUT input control multiplexers (shown in box "A" of Figure 2, page 4) there are signal flow control multiplexers (shown in box "B" of Figure 2) which select the signals which drive the flip-flop inputs and the combinatorial CLB outputs (X and Y).

Each flip-flop input is driven from a 4:1 multiplexer which selects among the three LUT outputs and DIN as the data source.

Each combinatorial output is driven from a 2:1 multiplexer which selects between two of the LUT outputs. The X output can be driven from the F-LUT or H-LUT, the Y output from G-LUT or H-LUT.

**Control Signals**

There are four signal control multiplexers on the input of the CLB. These multiplexers allow the internal CLB control signals (H1, DIN, SR, and EC in Figure 2 and Figure 4) to be driven from any of the four general control inputs (C1-C4 in Figure 4) into the CLB. Any of these inputs can drive any of the four internal control signals.



DS060\_04\_081100

Figure 4: CLB Control Signal Interface

The four internal control signals are:

- EC: Enable Clock
- SR: Asynchronous Set/Reset or H function generator Input 0
- DIN: Direct In or H function generator Input 2
- H1: H function generator Input 1.

### Input/Output Blocks (IOBs)

User-configurable input/output blocks (IOBs) provide the interface between external package pins and the internal logic. Each IOB controls one package pin and can be configured for input, output, or bidirectional signals. Figure 6 shows a simplified functional block diagram of the Spartan/XL FPGA IOB.



DS060\_05\_041901

Figure 5: IOB Flip-Flop/Latch Functional Block Diagram

### IOB Input Signal Path

The input signal to the IOB can be configured to either go directly to the routing channels (via I1 and I2 in Figure 6) or to the input register. The input register can be programmed as either an edge-triggered flip-flop or a level-sensitive latch. The functionality of this register is shown in Table 3, and a simplified block diagram of the register can be seen in Figure 5.

Table 3: Input Register Functionality

Mode	CK	EC	D	Q
Power-Up or GSR	X	X	X	SR
Flip-Flop		1*	D	D
	0	X	X	Q
Latch	1	1*	X	Q
	0	1*	D	D
Both	X	0	X	Q

**Legend:**

- X Don't care.
- Rising edge (clock not inverted).
- SR Set or Reset value. Reset is default.
- 0\* Input is Low or unconnected (default value)
- 1\* Input is High or unconnected (default value)

The register choice is made by placing the appropriate library symbol. For example, IFD is the basic input flip-flop (rising edge triggered), and ILD is the basic input latch (transparent-High). Variations with inverted clocks are also available. The clock signal inverter is also shown in [Figure 5](#) on the CK line.

The Spartan family IOB data input path has a one-tap delay element: either the delay is inserted (default), or it is not. The Spartan-XL family IOB data input path has a two-tap delay element, with choices of a full delay, a partial delay, or no delay. The added delay guarantees a zero hold time with respect to clocks routed through the global clock buffers. (See [Global Nets and Buffers](#), page 12 for a description of the global clock buffers in the Spartan/XL families.) For a shorter input register setup time, with positive hold-time, attach a NODELAY attribute or property to the flip-flop. The output of the input register goes to the routing channels (via I1 and I2 in [Figure 6](#)). The I1 and I2 signals that exit the IOB can each carry either the direct or registered input signal.

The 5V Spartan family input buffers can be globally configured for either TTL (1.2V) or CMOS ( $V_{CC}/2$ ) thresholds,

using an option in the bitstream generation software. The Spartan family output levels are also configurable; the two global adjustments of input threshold and output level are independent. The inputs of Spartan devices can be driven by the outputs of any 3.3V device, if the Spartan family inputs are in TTL mode. Input and output thresholds are TTL on all configuration pins until the configuration has been loaded into the device and specifies how they are to be used. Spartan-XL family inputs are TTL compatible and 3.3V CMOS compatible.

Supported sources for Spartan/XL device inputs are shown in [Table 4](#).

Spartan-XL family I/Os are fully 5V tolerant even though the  $V_{CC}$  is 3.3V. This allows 5V signals to directly connect to the Spartan-XL family inputs without damage, as shown in [Table 4](#). In addition, the 3.3V  $V_{CC}$  can be applied before or after 5V signals are applied to the I/Os. This makes the Spartan-XL devices immune to power supply sequencing problems.

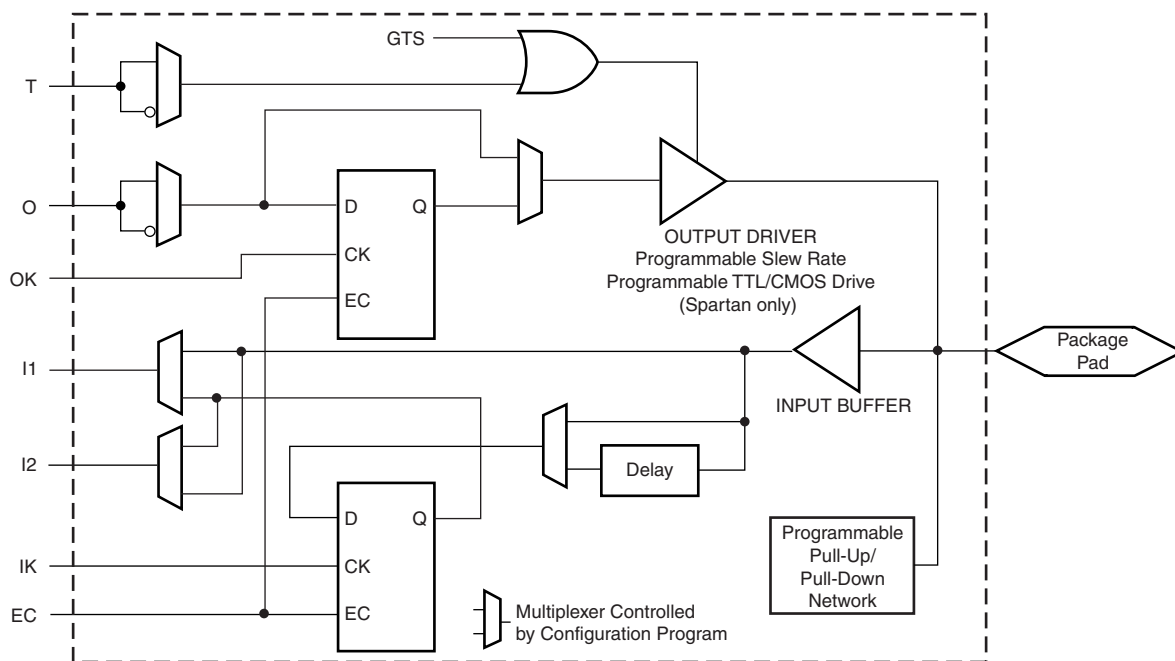

DS060\_06\_041901

Figure 6: Simplified Spartan/XL IOB Block Diagram

Table 4: Supported Sources for Spartan/XL Inputs

Source	Spartan Inputs		Spartan-XL Inputs
	5V, TTL	5V, CMOS	3.3V CMOS
Any device, $V_{CC} = 3.3V$ , CMOS outputs	√	Unreliable Data	√
Spartan family, $V_{CC} = 5V$ , TTL outputs	√		√
Any device, $V_{CC} = 5V$ , TTL outputs ( $V_{OH} \leq 3.7V$ )	√		√
Any device, $V_{CC} = 5V$ , CMOS outputs	√	√	√ (default mode)

**Spartan-XL Family  $V_{CC}$  Clamping**

Spartan-XL FPGAs have an optional clamping diode connected from each I/O to  $V_{CC}$ . When enabled they clamp ringing transients back to the 3.3V supply rail. This clamping action is required in 3.3V PCI applications.  $V_{CC}$  clamping is a global option affecting all I/O pins.

Spartan-XL devices are fully 5V TTL I/O compatible if  $V_{CC}$  clamping is not enabled. With  $V_{CC}$  clamping enabled, the Spartan-XL devices will begin to clamp input voltages to one diode voltage drop above  $V_{CC}$ . If enabled, TTL I/O compatibility is maintained but full 5V I/O tolerance is sacrificed. The user may select either 5V tolerance (default) or 3.3V PCI compatibility. In both cases negative voltage is clamped to one diode voltage drop below ground.

Spartan-XL devices are compatible with TTL, LVTTTL, PCI 3V, PCI 5V and LVCMOS signalling. The various standards are illustrated in Table 5.

Table 5: I/O Standards Supported by Spartan-XL FPGAs

Signaling Standard	VCC Clamping	Output Drive	$V_{IH\ MAX}$	$V_{IH\ MIN}$	$V_{IL\ MAX}$	$V_{OH\ MIN}$	$V_{OL\ MAX}$
TTL	Not allowed	12/24 mA	5.5	2.0	0.8	2.4	0.4
LVTTTL	OK	12/24 mA	3.6	2.0	0.8	2.4	0.4
PCI5V	Not allowed	24 mA	5.5	2.0	0.8	2.4	0.4
PCI3V	Required	12 mA	3.6	50% of $V_{CC}$	30% of $V_{CC}$	90% of $V_{CC}$	10% of $V_{CC}$
LVCMOS 3V	OK	12/24 mA	3.6	50% of $V_{CC}$	30% of $V_{CC}$	90% of $V_{CC}$	10% of $V_{CC}$

**Additional Fast Capture Input Latch (Spartan-XL Family Only)**

The Spartan-XL family OB has an additional optional latch on the input. This latch is clocked by the clock used for the output flip-flop rather than the input clock. Therefore, two different clocks can be used to clock the two input storage elements. This additional latch allows the fast capture of input data, which is then synchronized to the internal clock by the IOB flip-flop or latch.

To place the Fast Capture latch in a design, use one of the special library symbols, ILFFX or ILFLX. ILFFX is a transparent-Low Fast Capture latch followed by an active High input flip-flop. ILFLX is a transparent Low Fast Capture latch followed by a transparent High input latch. Any of the clock inputs can be inverted before driving the library element, and the inverter is absorbed into the IOB.

**IOB Output Signal Path**

Output signals can be optionally inverted within the IOB, and can pass directly to the output buffer or be stored in an edge-triggered flip-flop and then to the output buffer. The functionality of this flip-flop is shown in Table 6.

Table 6: Output Flip-Flop Functionality

Mode	Clock	Clock Enable	T	D	Q
Power-Up or GSR	X	X	0*	X	SR
Flip-Flop	X	0	0*	X	Q
		1*	0*	D	D
	X	X	1	X	Z
	0	X	0*	X	Q

**Legend:**

- X Don't care
- Rising edge (clock not inverted).
- SR Set or Reset value. Reset is default.
- 0\* Input is Low or unconnected (default value)
- 1\* Input is High or unconnected (default value)
- Z 3-state

### Output Multiplexer/2-Input Function Generator (Spartan-XL Family Only)

The output path in the Spartan-XL family IOB contains an additional multiplexer not available in the Spartan family IOB. The multiplexer can also be configured as a 2-input function generator, implementing a pass gate, AND gate, OR gate, or XOR gate, with 0, 1, or 2 inverted inputs.

When configured as a multiplexer, this feature allows two output signals to time-share the same output pad, effectively doubling the number of device outputs without requiring a larger, more expensive package. The select input is the pin used for the output flip-flop clock, OK.

When the multiplexer is configured as a 2-input function generator, logic can be implemented within the IOB itself. Combined with a Global buffer, this arrangement allows very high-speed gating of a single signal. For example, a wide decoder can be implemented in CLBs, and its output gated with a Read or Write Strobe driven by a global buffer.

The user can specify that the IOB function generator be used by placing special library symbols beginning with the letter "O." For example, a 2-input AND gate in the IOB function generator is called OAND2. Use the symbol input pin labeled "F" for the signal on the critical path. This signal is placed on the OK pin — the IOB input with the shortest delay to the function generator. Two examples are shown in [Figure 7](#).



Figure 7: AND and MUX Symbols in Spartan-XL IOB

### Output Buffer

An active High 3-state signal can be used to place the output buffer in a high-impedance state, implementing 3-state outputs or bidirectional I/O. Under configuration control, the output (O) and output 3-state (T) signals can be inverted. The polarity of these signals is independently configured for each IOB (see [Figure 6, page 7](#)). An output can be configured as open-drain (open-collector) by tying the 3-state pin (T) to the output signal, and the input pin (I) to Ground.

By default, a 5V Spartan device output buffer pull-up structure is configured as a TTL-like totem-pole. The High driver is an n-channel pull-up transistor, pulling to a voltage one transistor threshold below  $V_{CC}$ . Alternatively, the outputs can be globally configured as CMOS drivers, with additional p-channel pull-up transistors pulling to  $V_{CC}$ . This option, applied using the bitstream generation software, applies to all outputs on the device. It is not individually programmable.

All Spartan-XL device outputs are configured as CMOS drivers, therefore driving rail-to-rail. The Spartan-XL family outputs are individually programmable for 12 mA or 24 mA output drive.

Any 5V Spartan device with its outputs configured in TTL mode can drive the inputs of any typical 3.3V device. Supported destinations for Spartan/XL device outputs are shown in [Table 7](#).

### Three-State Register (Spartan-XL Family Only)

Spartan-XL devices incorporate an optional register controlling the three-state enable in the IOBs. The use of the three-state control register can significantly improve output enable and disable time.

### Output Slew Rate

The slew rate of each output buffer is, by default, reduced, to minimize power bus transients when switching non-critical signals. For critical signals, attach a FAST attribute or property to the output buffer or flip-flop.

Spartan/XL devices have a feature called "Soft Start-up," designed to reduce ground bounce when all outputs are turned on simultaneously at the end of configuration. When the configuration process is finished and the device starts up, the first activation of the outputs is automatically slew-rate limited. Immediately following the initial activation of the I/O, the slew rate of the individual outputs is determined by the individual configuration option for each IOB.

### Pull-up and Pull-down Network

Programmable pull-up and pull-down resistors are used for tying unused pins to  $V_{CC}$  or Ground to minimize power consumption and reduce noise sensitivity. The configurable pull-up resistor is a p-channel transistor that pulls to  $V_{CC}$ . The configurable pull-down resistor is an n-channel transistor that pulls to Ground. The value of these resistors is typically 20 K $\Omega$  – 100 K $\Omega$  (See "Spartan Family DC Characteristics Over Operating Conditions" on page 43.).

This high value makes them unsuitable as wired-AND pull-up resistors.

**Table 7: Supported Destinations for Spartan/XL Outputs**

Destination	Spartan-XL Outputs	Spartan Outputs	
	3.3V, CMOS	5V, TTL	5V, CMOS
Any device, $V_{CC} = 3.3V$ , CMOS-threshold inputs	√	√	Some <sup>(1)</sup>
Any device, $V_{CC} = 5V$ , TTL-threshold inputs	√	√	√
Any device, $V_{CC} = 5V$ , CMOS-threshold inputs	Unreliable Data		√

**Notes:**

1. Only if destination device has 5V tolerant inputs.

After configuration, voltage levels of unused pads, bonded or unbonded, must be valid logic levels, to reduce noise sensitivity and avoid excess current. Therefore, by default, unused pads are configured with the internal pull-up resistor active. Alternatively, they can be individually configured with the pull-down resistor, or as a driven output, or to be driven by an external source. To activate the internal pull-up, attach the PULLUP library component to the net attached to the pad. To activate the internal pull-down, attach the PULL-DOWN library component to the net attached to the pad.

**Set/Reset**

As with the CLB registers, the GSR signal can be used to set or clear the input and output registers, depending on the value of the INIT attribute or property. The two flip-flops can be individually configured to set or clear on reset and after configuration. Other than the global GSR net, no user-controlled set/reset signal is available to the I/O flip-flops (Figure 5). The choice of set or reset applies to both the initial state of the flip-flop and the response to the GSR pulse.

**Independent Clocks**

Separate clock signals are provided for the input (IK) and output (OK) flip-flops. The clock can be independently inverted for each flip-flop within the IOB, generating either

falling-edge or rising-edge triggered flip-flops. The clock inputs for each IOB are independent.

**Common Clock Enables**

The input and output flip-flops in each IOB have a common clock enable input (see EC signal in Figure 5), which through configuration, can be activated individually for the input or output flip-flop, or both. This clock enable operates exactly like the EC signal on the Spartan/XL FPGA CLB. It cannot be inverted within the IOB.

**Routing Channel Description**

All internal routing channels are composed of metal segments with programmable switching points and switching matrices to implement the desired routing. A structured, hierarchical matrix of routing channels is provided to achieve efficient automated routing.

This section describes the routing channels available in Spartan/XL devices. Figure 8 shows a general block diagram of the CLB routing channels. The implementation software automatically assigns the appropriate resources based on the density and timing requirements of the design. The following description of the routing channels is for information only and is simplified with some minor details omitted. For an exact interconnect description the designer should open a design in the FPGA Editor and review the actual connections in this tool.

The routing channels will be discussed as follows;

- CLB routing channels which run along each row and column of the CLB array.
- IOB routing channels which form a ring (called a VersaRing) around the outside of the CLB array. It connects the I/O with the CLB routing channels.
- Global routing consists of dedicated networks primarily designed to distribute clocks throughout the device with minimum delay and skew. Global routing can also be used for other high-fanout signals.

**CLB Routing Channels**

The routing channels around the CLB are derived from three types of interconnects; single-length, double-length, and longlines. At the intersection of each vertical and horizontal routing channel is a signal steering matrix called a Programmable Switch Matrix (PSM). Figure 8 shows the basic routing channel configuration showing single-length lines, double-length lines and longlines as well as the CLBs and PSMs. The CLB to routing channel interface is shown as well as how the PSMs interface at the channel intersections.

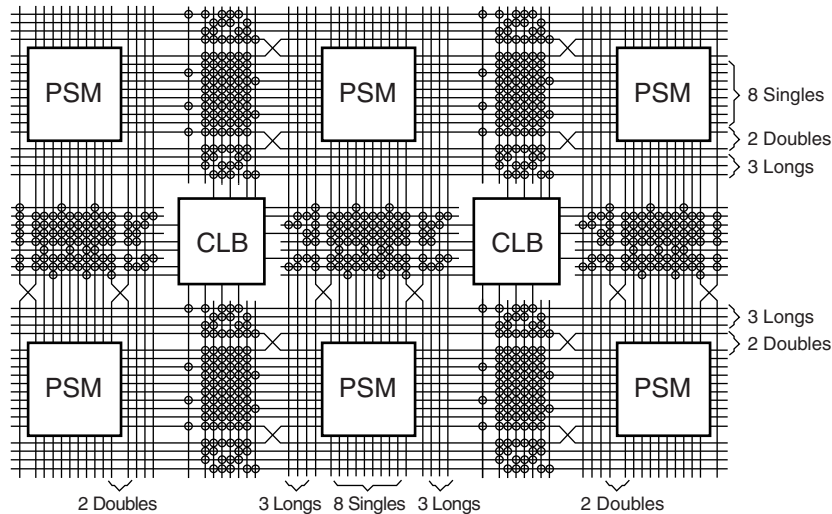

DS060\_09\_041901

Figure 8: Spartan/XL CLB Routing Channels and Interface Block Diagram

### CLB Interface

A block diagram of the CLB interface signals is shown in Figure 9. The input signals to the CLB are distributed evenly on all four sides providing maximum routing flexibility. In general, the entire architecture is symmetrical and regular. It is well suited to established placement and routing algorithms. Inputs, outputs, and function generators can freely swap positions within a CLB to avoid routing congestion during the placement and routing operation. The exceptions are the clock (K) input and CIN/COU signals. The K input is routed to dedicated global vertical lines as well as four single-length lines and is on the left side of the CLB. The CIN/COU signals are routed through dedicated interconnects which do not interfere with the general routing structure. The output signals from the CLB are available to drive both vertical and horizontal channels.

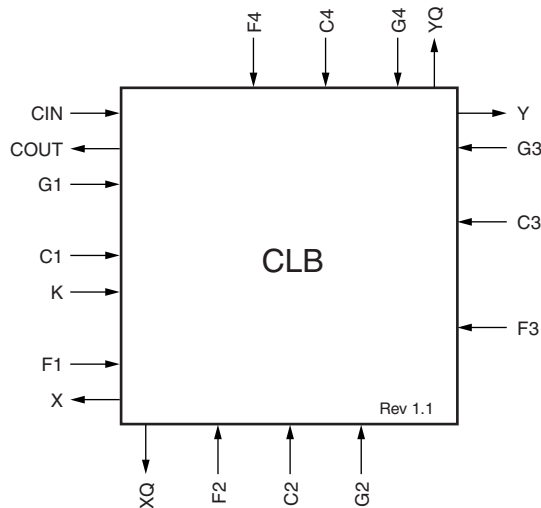

DS060\_08\_081100

Figure 9: CLB Interconnect Signals

### Programmable Switch Matrices

The horizontal and vertical single- and double-length lines intersect at a box called a programmable switch matrix (PSM). Each PSM consists of programmable pass transistors used to establish connections between the lines (see Figure 10).

For example, a single-length signal entering on the right side of the switch matrix can be routed to a single-length line on the top, left, or bottom sides, or any combination thereof, if multiple branches are required. Similarly, a double-length signal can be routed to a double-length line on any or all of the other three edges of the programmable switch matrix.

### Single-Length Lines

Single-length lines provide the greatest interconnect flexibility and offer fast routing between adjacent blocks. There are eight vertical and eight horizontal single-length lines associated with each CLB. These lines connect the switching matrices that are located in every row and column of CLBs. Single-length lines are connected by way of the programmable switch matrices, as shown in Figure 10. Routing connectivity is shown in Figure 8.

Single-length lines incur a delay whenever they go through a PSM. Therefore, they are not suitable for routing signals for long distances. They are normally used to conduct signals within a localized area and to provide the branching for nets with fanout greater than one.



Figure 10: Programmable Switch Matrix

### Double-Length Lines

The double-length lines consist of a grid of metal segments, each twice as long as the single-length lines: they run past two CLBs before entering a PSM. Double-length lines are grouped in pairs with the PSMs staggered, so that each line goes through a PSM at every other row or column of CLBs (see [Figure 8](#)).

There are four vertical and four horizontal double-length lines associated with each CLB. These lines provide faster signal routing over intermediate distances, while retaining routing flexibility.

### Longlines

Longlines form a grid of metal interconnect segments that run the entire length or width of the array. Longlines are intended for high fan-out, time-critical signal nets, or nets that are distributed over long distances.

Each Spartan/XL device longline has a programmable splitter switch at its center. This switch can separate the line into two independent routing channels, each running half the width or height of the array.

Routing connectivity of the longlines is shown in [Figure 8](#). The longlines also interface to some 3-state buffers which is described later in [3-State Long Line Drivers](#), page 19.

### I/O Routing

Spartan/XL devices have additional routing around the IOB ring. This routing is called a VersaRing. The VersaRing facilitates pin-swapping and redesign without affecting board layout. Included are eight double-length lines, and four longlines.

### Global Nets and Buffers

The Spartan/XL devices have dedicated global networks. These networks are designed to distribute clocks and other high fanout control signals throughout the devices with minimal skew.

Four vertical longlines in each CLB column are driven exclusively by special global buffers. These longlines are in addition to the vertical longlines used for standard interconnect. In the 5V Spartan devices, the four global lines can be driven by either of two types of global buffers; Primary Global buffers (BUFGP) or Secondary Global buffers (BUFGS). Each of these lines can be accessed by one particular Primary Global buffer, or by any of the Secondary Global buffers, as shown in [Figure 11](#). In the 3V Spartan-XL devices, the four global lines can be driven by any of the eight Global Low-Skew Buffers (BUFGLS). The clock pins of every CLB and IOB can also be sourced from local interconnect.



Figure 11: 5V Spartan Family Global Net Distribution

The four Primary Global buffers offer the shortest delay and negligible skew. Four Secondary Global buffers have slightly longer delay and slightly more skew due to potentially heavier loading, but offer greater flexibility when used to drive non-clock CLB inputs. The eight Global Low-Skew buffers in the Spartan-XL devices combine short delay, negligible skew, and flexibility.

The Primary Global buffers must be driven by the semi-dedicated pads (PGCK1-4). The Secondary Global buffers can be sourced by either semi-dedicated pads (SGCK1-4) or internal nets. Each corner of the device has one Primary buffer and one Secondary buffer. The Spartan-XL family has eight global low-skew buffers, two in each corner. All can be sourced by either semi-dedicated pads (GCK1-8) or internal nets.

Using the library symbol called BUFG results in the software choosing the appropriate clock buffer, based on the timing requirements of the design. A global buffer should be specified for all timing-sensitive global signal distribution. To use a global buffer, place a BUFGP (primary buffer), BUFGS (secondary buffer), BUFGLS (Spartan-XL family global low-skew buffer), or BUFG (any buffer type) element in a schematic or in HDL code.

## Advanced Features Description

### Distributed RAM

Optional modes for each CLB allow the function generators (F-LUT and G-LUT) to be used as Random Access Memory (RAM).

Read and write operations are significantly faster for this on-chip RAM than for off-chip implementations. This speed advantage is due to the relatively short signal propagation delays within the FPGA.

### Memory Configuration Overview

There are two available memory configuration modes: single-port RAM and dual-port RAM. For both these modes, write operations are synchronous (edge-triggered), while read operations are asynchronous. In the single-port mode, a single CLB can be configured as either a 16 x 1, (16 x 1) x 2, or 32 x 1 RAM array. In the dual-port mode, a single CLB can be configured only as one 16 x 1 RAM array. The different CLB memory configurations are summarized in Table 8. Any of these possibilities can be individually programmed into a Spartan/XL FPGA CLB.

Table 8: CLB Memory Configurations

Mode	16 x 1	(16 x 1) x 2	32 x 1
Single-Port	√	√	√
Dual-Port	√	—	—

- The 16 x 1 single-port configuration contains a RAM array with 16 locations, each one-bit wide. One 4-bit address decoder determines the RAM location for write and read operations. There is one input for writing data and one output for reading data, all at the selected address.
- The (16 x 1) x 2 single-port configuration combines two 16 x 1 single-port configurations (each according to the preceding description). There is one data input, one data output and one address decoder for each array. These arrays can be addressed independently.
- The 32 x 1 single-port configuration contains a RAM array with 32 locations, each one-bit wide. There is one data input, one data output, and one 5-bit address decoder.
- The dual-port mode 16 x 1 configuration contains a RAM array with 16 locations, each one-bit wide. There are two 4-bit address decoders, one for each port. One port consists of an input for writing and an output for reading, all at a selected address. The other port consists of one output for reading from an independently selected address.

The appropriate choice of RAM configuration mode for a given design should be based on timing and resource requirements, desired functionality, and the simplicity of the design process. Selection criteria include the following: Whereas the 32 x 1 single-port, the (16 x 1) x 2 single-port, and the 16 x 1 dual-port configurations each use one entire CLB, the 16 x 1 single-port configuration uses only one half of a CLB. Due to its simultaneous read/write capability, the dual-port RAM can transfer twice as much data as the single-port RAM, which permits only one data operation at any given time.

CLB memory configuration options are selected by using the appropriate library symbol in the design entry.

### Single-Port Mode

There are three CLB memory configurations for the single-port RAM: 16 x 1, (16 x 1) x 2, and 32 x 1, the functional organization of which is shown in [Figure 12](#).

The single-port RAM signals and the CLB signals ([Figure 2](#), [page 4](#)) from which they are originally derived are shown in [Table 9](#).

Table 9: Single-Port RAM Signals

RAM Signal	Function	CLB Signal
D0 or D1	Data In	DIN or H1
A[3:0]	Address	F[4:1] or G[4:1]
A4 (32 x 1 only)	Address	H1
WE	Write Enable	SR
WCLK	Clock	K
SPO	Single Port Out (Data Out)	F <sub>OUT</sub> or G <sub>OUT</sub>



### Notes:

1. The (16 x 1) x 2 configuration combines two 16 x 1 single-port RAMs, each with its own independent address bus and data input. The same WE and WCLK signals are connected to both RAMs.
2. n = 4 for the 16 x 1 and (16 x 1) x 2 configurations. n = 5 for the 32 x 1 configuration.

Figure 12: Logic Diagram for the Single-Port RAM

Writing data to the single-port RAM is essentially the same as writing to a data register. It is an edge-triggered (synchronous) operation performed by applying an address to the A inputs and data to the D input during the active edge of WCLK while WE is High.

The timing relationships are shown in [Figure 13](#). The High logic level on WE enables the input data register for writing. The active edge of WCLK latches the address, input data, and WE signals. Then, an internal write pulse is generated that loads the data into the memory cell.

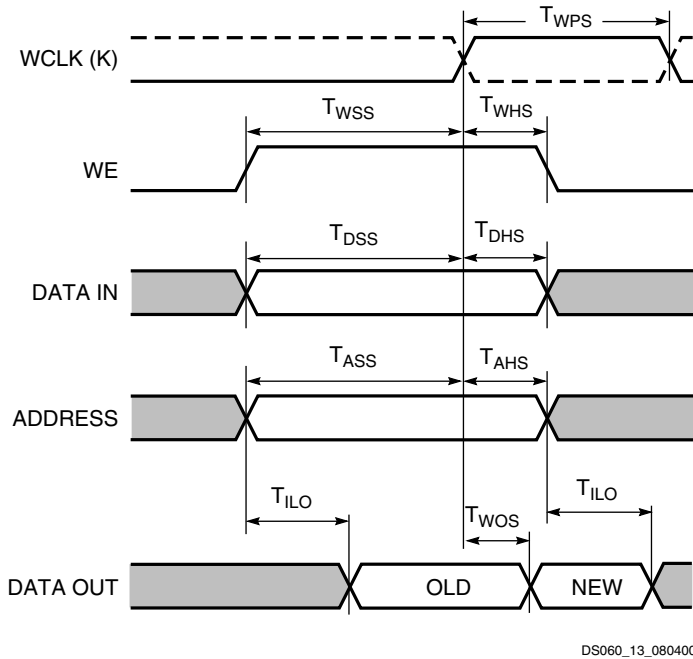

DS060\_13\_080400

Figure 13: Data Write and Access Timing for RAM

WCLK can be configured as active on either the rising edge (default) or the falling edge. While the WCLK input to the RAM accepts the same signal as the clock input to the associated CLB's flip-flops, the sense of this WCLK input can be

inverted with respect to the sense of the flip-flop clock inputs. Consequently, within the same CLB, data at the RAM SPO line can be stored in a flip-flop with either the same or the inverse clock polarity used to write data to the RAM.

The WE input is active High and cannot be inverted within the CLB.

Allowing for settling time, the data on the SPO output reflects the contents of the RAM location currently addressed. When the address changes, following the asynchronous delay  $T_{ILO}$ , the data stored at the new address location will appear on SPO. If the data at a particular RAM address is overwritten, after the delay  $T_{WOS}$ , the new data will appear on SPO.

**Dual-Port Mode**

In dual-port mode, the function generators (F-LUT and G-LUT) are used to create a 16 x 1 dual-port memory. Of the two data ports available, one permits read and write operations at the address specified by A[3:0] while the second provides only for read operations at the address specified independently by DPRA[3:0]. As a result, simultaneous read/write operations at different addresses (or even at the same address) are supported.

The functional organization of the 16 x 1 dual-port RAM is shown in Figure 14. The dual-port RAM signals and the

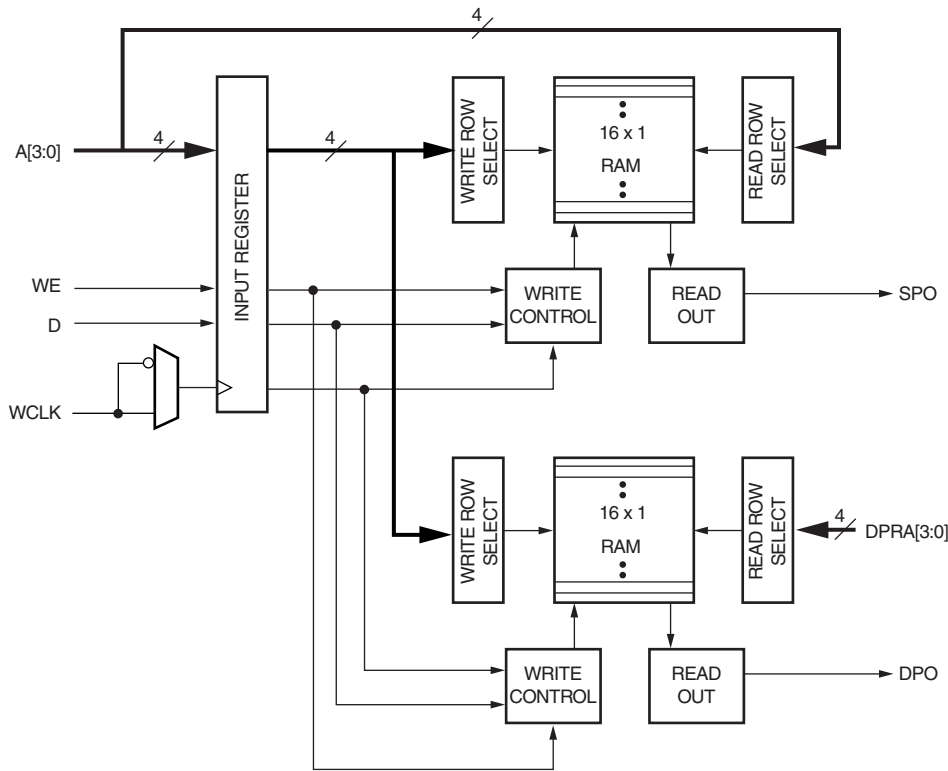

DS060\_14\_043001

Figure 14: Logic Diagram for the Dual-Port RAM

CLB signals from which they are originally derived are shown in Table 10.

Table 10: Dual-Port RAM Signals

RAM Signal	Function	CLB Signal
D	Data In	DIN
A[3:0]	Read Address for Single-Port. Write Address for Single-Port and Dual-Port.	F[4:1]
DPRA[3:0]	Read Address for Dual-Port	G[4:1]
WE	Write Enable	SR
WCLK	Clock	K
SPO	Single Port Out (addressed by A[3:0])	F <sub>OUT</sub>
DPO	Dual Port Out (addressed by DPRA[3:0])	G <sub>OUT</sub>

The RAM16X1D primitive used to instantiate the dual-port RAM consists of an upper and a lower 16 x 1 memory array. The address port labeled A[3:0] supplies both the read and write addresses for the lower memory array, which behaves the same as the 16 x 1 single-port RAM array described previously. Single Port Out (SPO) serves as the data output for the lower memory. Therefore, SPO reflects the data at address A[3:0].

The other address port, labeled DPRA[3:0] for Dual Port Read Address, supplies the read address for the upper memory. The write address for this memory, however, comes from the address A[3:0]. Dual Port Out (DPO) serves as the data output for the upper memory. Therefore, DPO reflects the data at address DPRA[3:0].

By using A[3:0] for the write address and DPRA[3:0] for the read address, and reading only the DPO output, a FIFO that can read and write simultaneously is easily generated. The simultaneous read/write capability possible with the dual-port RAM can provide twice the effective data throughput of a single-port RAM alternating read and write operations.

The timing relationships for the dual-port RAM mode are shown in Figure 13.

Note that write operations to RAM are synchronous (edge-triggered); however, data access is asynchronous.

**Initializing RAM at FPGA Configuration**

Both RAM and ROM implementations in the Spartan/XL families are initialized during device configuration. The initial contents are defined via an INIT attribute or property

attached to the RAM or ROM symbol, as described in the library guide. If not defined, all RAM contents are initialized to zeros, by default.

RAM initialization occurs only during device configuration. The RAM content is not affected by GSR.

**More Information on Using RAM Inside CLBs**

Three application notes are available from Xilinx that discuss synchronous (edge-triggered) RAM: "Xilinx Edge-Triggered and Dual-Port RAM Capability," "Implementing FIFOs in Xilinx RAM," and "Synchronous and Asynchronous FIFO Designs." All three application notes apply to both the Spartan and the Spartan-XL families.

**Fast Carry Logic**

Each CLB F-LUT and G-LUT contains dedicated arithmetic logic for the fast generation of carry and borrow signals. This extra output is passed on to the function generator in the adjacent CLB. The carry chain is independent of normal routing resources. (See Figure 15.)

Dedicated fast carry logic greatly increases the efficiency and performance of adders, subtractors, accumulators, comparators and counters. It also opens the door to many new applications involving arithmetic operation, where the previous generations of FPGAs were not fast enough or too inefficient. High-speed address offset calculations in micro-processor or graphics systems, and high-speed addition in digital signal processing are two typical applications.

The two 4-input function generators can be configured as a 2-bit adder with built-in hidden carry that can be expanded to any length. This dedicated carry circuitry is so fast and efficient that conventional speed-up methods like carry generate/propagate are meaningless even at the 16-bit level, and of marginal benefit at the 32-bit level. This fast carry logic is one of the more significant features of the Spartan

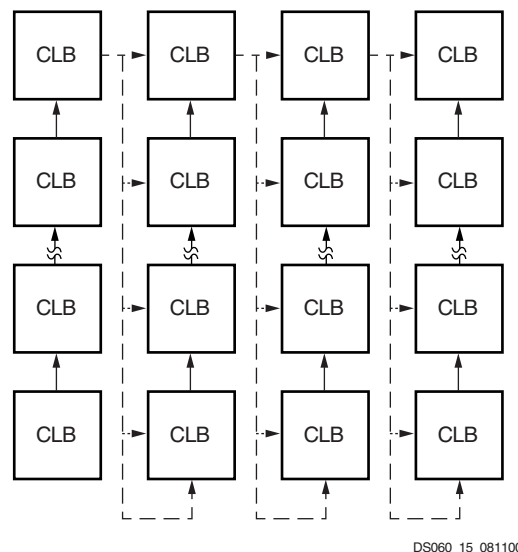

Figure 15: Available Spartan/XL Carry Propagation Paths

and Spartan-XL families, speeding up arithmetic and counting functions.

The carry chain in 5V Spartan devices can run either up or down. At the top and bottom of the columns where there are no CLBs above and below, the carry is propagated to the right. The default is always to propagate up the column, as shown in the figures. The carry chain in Spartan-XL devices can only run up the column, providing even higher speed.

**Figure 16, page 18** shows a Spartan/XL FPGA CLB with dedicated fast carry logic. The carry logic shares operand

and control inputs with the function generators. The carry outputs connect to the function generators, where they are combined with the operands to form the sums.

**Figure 17, page 19** shows the details of the Spartan/XL FPGA carry logic. This diagram shows the contents of the box labeled "CARRY LOGIC" in **Figure 16**.

The fast carry logic can be accessed by placing special library symbols, or by using Xilinx Relationally Placed Macros (RPMs) that already include these symbols.



DS060\_16\_080400

Figure 16: Fast Carry Logic in Spartan/XL CLB

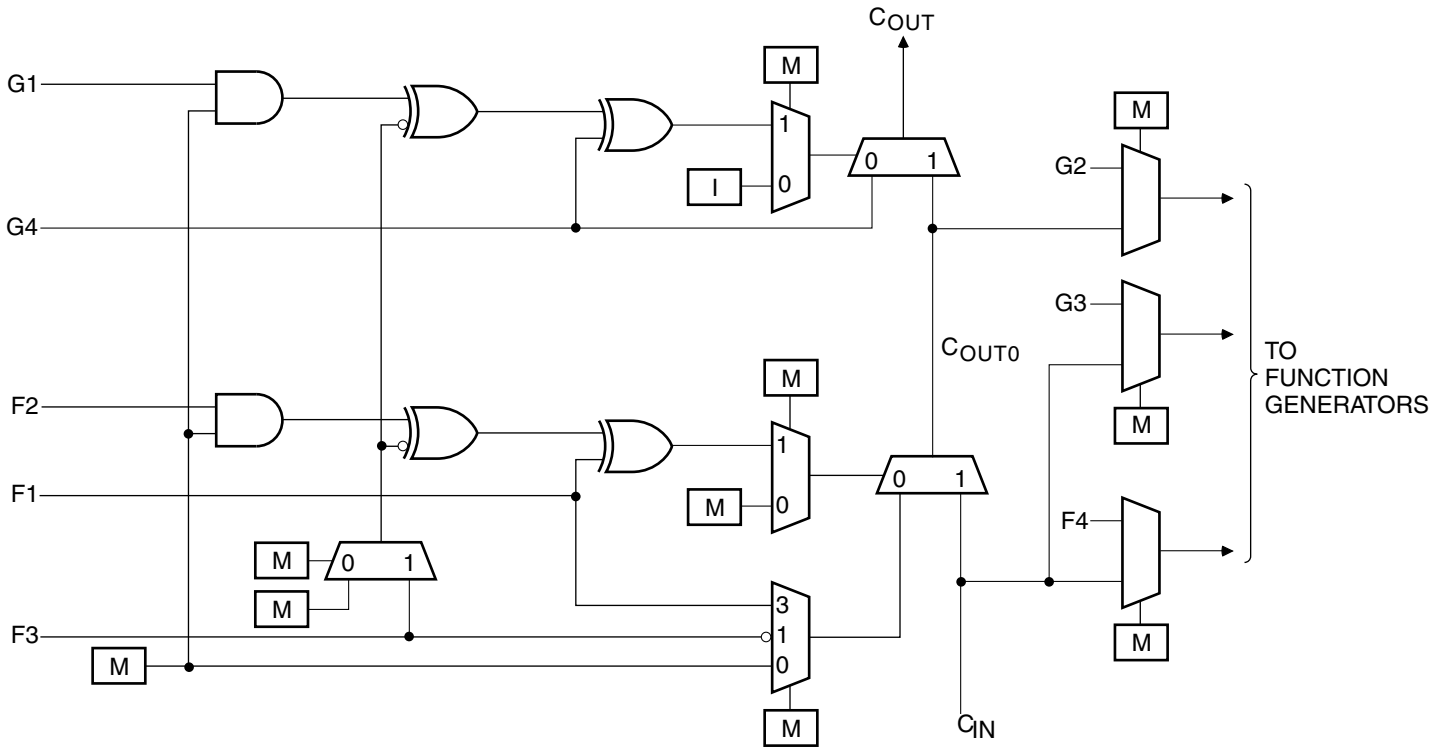

DS060\_17\_080400

Figure 17: Detail of Spartan/XL Dedicated Carry Logic

### 3-State Long Line Drivers

A pair of 3-state buffers is associated with each CLB in the array. These 3-state buffers (BUFT) can be used to drive signals onto the nearest horizontal longlines above and below the CLB. They can therefore be used to implement multiplexed or bidirectional buses on the horizontal longlines, saving logic resources.

There is a weak keeper at each end of these two horizontal longlines. This circuit prevents undefined floating levels. However, it is overridden by any driver.

The buffer enable is an active High 3-state (i.e., an active Low enable), as shown in Table 11.

### Three-State Buffer Example

Figure 18 shows how to use the 3-state buffers to implement a multiplexer. The selection is accomplished by the buffer 3-state signal.

Pay particular attention to the polarity of the T pin when using these buffers in a design. Active High 3-state (T) is identical to an active Low output enable, as shown in Table 11.

Table 11: Three-State Buffer Functionality

IN	T	OUT
X	1	Z
IN	0	IN

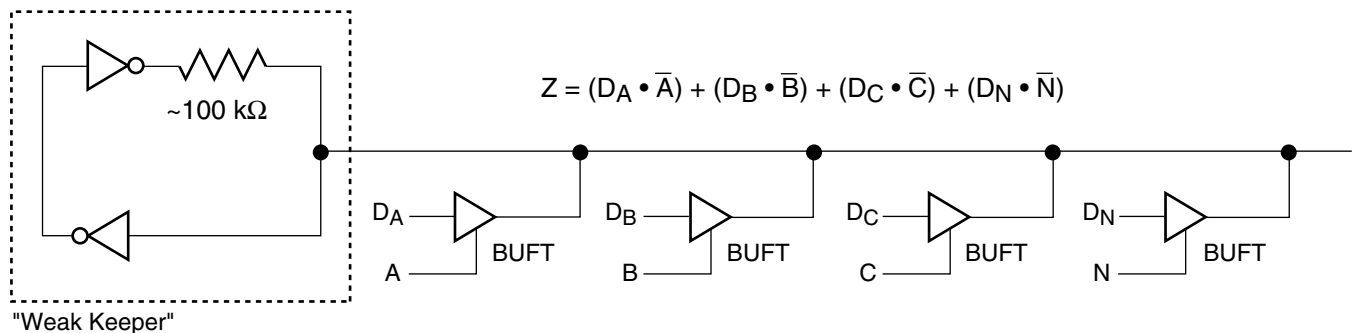

DS060\_18\_080400

Figure 18: 3-state Buffers Implement a Multiplexer

## On-Chip Oscillator

Spartan/XL devices include an internal oscillator. This oscillator is used to clock the power-on time-out, for configuration memory clearing, and as the source of CCLK in Master configuration mode. The oscillator runs at a nominal 8 MHz frequency that varies with process,  $V_{CC}$ , and temperature. The output frequency falls between 4 MHz and 10 MHz.

The oscillator output is optionally available after configuration. Any two of four resynchronized taps of a built-in divider are also available. These taps are at the fourth, ninth, fourteenth and nineteenth bits of the divider. Therefore, if the primary oscillator output is running at the nominal 8 MHz, the user has access to an 8-MHz clock, plus any two of 500 kHz, 16 kHz, 490 Hz and 15 Hz. These frequencies can vary by as much as -50% or +25%.

These signals can be accessed by placing the OSC4 library element in a schematic or in HDL code. The oscillator is automatically disabled after configuration if the OSC4 symbol is not used in the design.

## Global Signals: GSR and GTS

### Global Set/Reset

A separate Global Set/Reset line, as shown in [Figure 3, page 5](#) for the CLB and [Figure 5, page 6](#) for the IOB, sets or clears each flip-flop during power-up, reconfiguration, or when a dedicated Reset net is driven active. This global net (GSR) does not compete with other routing resources; it uses a dedicated distribution network.

Each flip-flop is configured as either globally set or reset in the same way that the local set/reset (SR) is specified. Therefore, if a flip-flop is set by SR, it is also set by GSR. Similarly, if in reset mode, it is reset by both SR and GSR.

GSR can be driven from any user-programmable pin as a global reset input. To use this global net, place an input pad and input buffer in the schematic or HDL code, driving the GSR pin of the STARTUP symbol. (See [Figure 19.](#)) A specific pin location can be assigned to this input using a LOC attribute or property, just as with any other user-programmable pad. An inverter can optionally be inserted after the input buffer to invert the sense of the GSR signal. Alternatively, GSR can be driven from any internal node.

### Global 3-State

A separate Global 3-state line (GTS) as shown in [Figure 6, page 7](#) forces all FPGA outputs to the high-impedance state, unless boundary scan is enabled and is executing an EXTEST instruction. GTS does not compete with other routing resources; it uses a dedicated distribution network.

GTS can be driven from any user-programmable pin as a global 3-state input. To use this global net, place an input pad and input buffer in the schematic or HDL code, driving the GTS pin of the STARTUP symbol. This is similar to what is shown in [Figure 19](#) for GSR except the IBUF would be

connected to GTS. A specific pin location can be assigned to this input using a LOC attribute or property, just as with any other user-programmable pad. An inverter can optionally be inserted after the input buffer to invert the sense of the Global 3-state signal. Alternatively, GTS can be driven from any internal node.

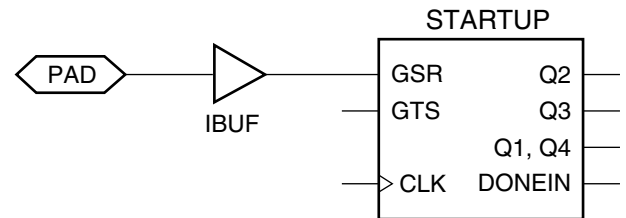

DS060\_19\_080400

Figure 19: Symbols for Global Set/Reset

## Boundary Scan

The "bed of nails" has been the traditional method of testing electronic assemblies. This approach has become less appropriate, due to closer pin spacing and more sophisticated assembly methods like surface-mount technology and multi-layer boards. The IEEE Boundary Scan Standard 1149.1 was developed to facilitate board-level testing of electronic assemblies. Design and test engineers can embed a standard test logic structure in their device to achieve high fault coverage for I/O and internal logic. This structure is easily implemented with a four-pin interface on any boundary scan compatible device. IEEE 1149.1-compatible devices may be serial daisy-chained together, connected in parallel, or a combination of the two.

The Spartan and Spartan-XL families implement IEEE 1149.1-compatible BYPASS, PRELOAD/SAMPLE and EXTEST boundary scan instructions. When the boundary scan configuration option is selected, three normal user I/O pins become dedicated inputs for these functions. Another user output pin becomes the dedicated boundary scan output. The details of how to enable this circuitry are covered later in this section.

By exercising these input signals, the user can serially load commands and data into these devices to control the driving of their outputs and to examine their inputs. This method is an improvement over bed-of-nails testing. It avoids the need to over-drive device outputs, and it reduces the user interface to four pins. An optional fifth pin, a reset for the control logic, is described in the standard but is not implemented in the Spartan/XL devices.

The dedicated on-chip logic implementing the IEEE 1149.1 functions includes a 16-state machine, an instruction register and a number of data registers. The functional details can be found in the IEEE 1149.1 specification and are also discussed in the Xilinx application note: "*Boundary Scan in FPGA Devices.*"



Figure 20 is a diagram of the Spartan/XL FPGA boundary scan logic. It includes three bits of Data Register per IOB, the IEEE 1149.1 Test Access Port controller, and the Instruction Register with decodes.

Spartan/XL devices can also be configured through the boundary scan logic. See **Configuration Through the Boundary Scan Pins**, page 37.

### **Data Registers**

The primary data register is the boundary scan register. For each IOB pin in the FPGA, bonded or not, it includes three bits for In, Out and 3-state Control. Non-IOB pins have appropriate partial bit population for In or Out only. PROGRAM, CCLK and DONE are not included in the boundary scan register. Each EXTEST CAPTURE-DR state captures all In, Out, and 3-state pins.

The data register also includes the following non-pin bits: TDO.T, and TDO.O, which are always bits 0 and 1 of the data register, respectively, and BSCANT.UPD, which is always the last bit of the data register. These three boundary scan bits are special-purpose Xilinx test signals.

The other standard data register is the single flip-flop BYPASS register. It synchronizes data being passed through the FPGA to the next downstream boundary scan device.

The FPGA provides two additional data registers that can be specified using the BSCAN macro. The FPGA provides two user pins (BSCAN.SEL1 and BSCAN.SEL2) which are the decodes of two user instructions. For these instructions, two corresponding pins (BSCAN.TDO1 and BSCAN.TDO2) allow user scan data to be shifted out on TDO. The data register clock (BSCAN.DRCK) is available for control of test logic which the user may wish to implement with CLBs. The NAND of TCK and RUN-TEST-IDLE is also provided (BSCAN.IDLE).

### **Instruction Set**

The Spartan/XL FPGA boundary scan instruction set also includes instructions to configure the device and read back the configuration data. The instruction set is coded as shown in **Table 12**.



DS060\_20\_080400

Figure 20: Spartan/XL Boundary Scan Logic

Table 12: Boundary Scan Instructions

Instruction			Test Selected	TDO Source	I/O Data Source
I2	I1	I0			
0	0	0	EXTEST	DR	DR
0	0	1	SAMPLE/ PRELOAD	DR	Pin/Logic
0	1	0	USER 1	BSCAN. TDO1	User Logic
0	1	1	USER 2	BSCAN. TDO2	User Logic
1	0	0	READBACK	Readback Data	Pin/Logic
1	0	1	CONFIGURE	DOUT	Disabled
1	1	0	IDCODE (Spartan-XL only)	IDCODE Register	-
1	1	1	BYPASS	Bypass Register	-

**Bit Sequence**

The bit sequence within each IOB is: In, Out, 3-state. The input-only pins contribute only the In bit to the boundary scan I/O data register, while the output-only pins contributes all three bits.

The first two bits in the I/O data register are TDO.T and TDO.O, which can be used for the capture of internal signals. The final bit is BSCANT.UPD, which can be used to drive an internal net. These locations are primarily used by Xilinx for internal testing.

From a cavity-up view of the chip (as shown in the FPGA Editor), starting in the upper right chip corner, the boundary scan data-register bits are ordered as shown in Figure 21. The device-specific pinout tables for the Spartan/XL devices include the boundary scan locations for each IOB pin.



DS060\_21\_080400

Figure 21: Boundary Scan Bit Sequence

BSDL (Boundary Scan Description Language) files for Spartan/XL devices are available on the Xilinx website in the File Download area. Note that the 5V Spartan devices and 3V Spartan-XL devices have different BSDL files.

**Including Boundary Scan in a Design**

If boundary scan is only to be used during configuration, no special elements need be included in the schematic or HDL code. In this case, the special boundary scan pins TDI, TMS, TCK and TDO can be used for user functions after configuration.

To indicate that boundary scan remain enabled after configuration, place the BSCAN library symbol and connect the TDI, TMS, TCK and TDO pad symbols to the appropriate pins, as shown in Figure 22.



DS060\_22\_080400

Figure 22: Boundary Scan Example

Even if the boundary scan symbol is used in a design, the input pins TMS, TCK, and TDI can still be used as inputs to be routed to internal logic. Care must be taken not to force the chip into an undesired boundary scan state by inadvertently applying boundary scan input patterns to these pins. The simplest way to prevent this is to keep TMS High, and then apply whatever signal is desired to TDI and TCK.

### Avoiding Inadvertent Boundary Scan

If TMS or TCK is used as user I/O, care must be taken to ensure that at least one of these pins is held constant during configuration. In some applications, a situation may occur where TMS or TCK is driven during configuration. This may cause the device to go into boundary scan mode and disrupt the configuration process.

To prevent activation of boundary scan during configuration, do either of the following:

- TMS: Tie High to put the Test Access Port controller in a benign RESET state.
- TCK: Tie High or Low—do not toggle this clock input.

For more information regarding boundary scan, refer to the Xilinx Application Note, "*Boundary Scan in FPGA Devices.*"

### Boundary Scan Enhancements (Spartan-XL Family Only)

Spartan-XL devices have improved boundary scan functionality and performance in the following areas:

**IDCODE:** The IDCODE register is supported. By using the IDCODE, the device connected to the JTAG port can be determined. The use of the IDCODE enables selective configuration dependent on the FPGA found.

The IDCODE register has the following binary format:

```
vvvv:ffff:fffa:aaaa:aaaa:cccc:cccc:ccc1
```

where

- c = the company code (49h for Xilinx)
- a = the array dimension in CLBs (ranges from 0Ah for XCS05XL to 1Ch for XCS40XL)
- f = the family code (02h for Spartan-XL family)
- v = the die version number

Table 13: IDCODEs Assigned to Spartan-XL FPGAs

FPGA	IDCODE
XCS05XL	0040A093h
XCS10XL	0040E093h
XCS20XL	00414093h
XCS30XL	00418093h
XCS40XL	0041C093h

**Configuration State:** The configuration state is available to JTAG controllers.

**Configuration Disable:** The JTAG port can be prevented from configuring the FPGA.

**TCK Startup:** TCK can now be used to clock the start-up block in addition to other user clocks.

**CCLK Holdoff:** Changed the requirement for Boundary Scan Configure or EXTEST to be issued prior to the release of INIT pin and CCLK cycling.

**Reissue Configure:** The Boundary Scan Configure can be reissued to recover from an unfinished attempt to configure the device.

**Bypass FF:** Bypass FF and IOB is modified to provide DRCLOCK only during BYPASS for the bypass flip-flop, and during EXTEST or SAMPLE/PRELOAD for the IOB register.

### Power-Down (Spartan-XL Family Only)

All Spartan/XL devices use a combination of efficient segmented routing and advanced process technology to provide low power consumption under all conditions. The 3.3V Spartan-XL family adds a dedicated active Low power-down pin ( $\overline{\text{PWRDWN}}$ ) to reduce supply current to 100  $\mu\text{A}$  typical. The  $\overline{\text{PWRDWN}}$  pin takes advantage of one of the unused No Connect locations on the 5V Spartan device. The user must de-select the "5V Tolerant I/Os" option in the Configuration Options to achieve the specified Power Down current. The  $\overline{\text{PWRDWN}}$  pin has a default internal pull-up resistor, allowing it to be left unconnected if unused.

$V_{\text{CC}}$  must continue to be supplied during Power-down, and configuration data is maintained. When the  $\overline{\text{PWRDWN}}$  pin is pulled Low, the input and output buffers are disabled. The inputs are internally forced to a logic Low level, including the MODE pins, DONE, CCLK, and TDO, and all internal pull-up resistors are turned off. The  $\overline{\text{PROGRAM}}$  pin is not affected by Power Down. The GSR net is asserted during Power Down, initializing all the flip-flops to their start-up state.

$\overline{\text{PWRDWN}}$  has a minimum pulse width of 50 ns (Figure 23). On entering the Power-down state, the inputs will be disabled and the flip-flops set/reset, and then the outputs are disabled about 10 ns later. The user may prefer to assert the GTS or GSR signals before  $\overline{\text{PWRDWN}}$  to affect the order of events. When the  $\overline{\text{PWRDWN}}$  signal is returned High, the inputs will be enabled first, followed immediately by the release of the GSR signal initializing the flip-flops. About 10 ns later, the outputs will be enabled. Allow 50 ns after the release of  $\overline{\text{PWRDWN}}$  before using the device.



Description	Symbol	Min
Power Down Time	$T_{PVD}$	50 ns
Power Down Pulse Width	$T_{PVDW}$	50 ns

DS060\_23\_041901

Figure 23:  $\overline{PWRDWN}$  Pulse Timing

Power-down retains the configuration, but loses all data stored in the device flip-flops. All inputs are interpreted as Low, but the internal combinatorial logic is fully functional. Make sure that the combination of all inputs Low and all flip-flops set or reset in your design will not generate internal oscillations, or create permanent bus contention by activating internal bus drivers with conflicting data onto the same long line.

During configuration, the  $\overline{PWRDWN}$  pin must be High. If the Power Down state is entered before or during configuration, the device will restart configuration once the  $\overline{PWRDWN}$  signal is removed. Note that the configuration pins are affected by Power Down and may not reflect their normal function. If there is an external pull-up resistor on the DONE pin, it will be High during Power Down even if the device is not yet configured. Similarly, if  $\overline{PWRDWN}$  is asserted before configuration is completed, the  $\overline{INIT}$  pin will not indicate status information.

Note that the  $\overline{PWRDWN}$  pin is not part of the Boundary Scan chain. Therefore, the Spartan-XL family has a separate set of BSDL files than the 5V Spartan family. Boundary scan logic is not usable during Power Down.

## Configuration and Test

Configuration is the process of loading design-specific programming data into one or more FPGAs to define the functional operation of the internal blocks and their interconnections. This is somewhat like loading the command registers of a programmable peripheral chip. Spartan/XL devices use several hundred bits of configuration data per CLB and its associated interconnects. Each configuration bit defines the state of a static memory cell

that controls either a function look-up table bit, a multiplexer input, or an interconnect pass transistor. The Xilinx development system translates the design into a netlist file. It automatically partitions, places and routes the logic and generates the configuration data in PROM format.

## Configuration Mode Control

5V Spartan devices have two configuration modes.

- MODE = 1 sets Slave Serial mode
- MODE = 0 sets Master Serial mode

3V Spartan-XL devices have three configuration modes.

- M1/M0 = 11 sets Slave Serial mode
- M1/M0 = 10 sets Master Serial mode
- M1/M0 = 0X sets Express mode

In addition to these modes, the device can be configured through the Boundary Scan logic (See "Configuration Through the Boundary Scan Pins" on page 37.).

The Mode pins are sampled prior to starting configuration to determine the configuration mode. After configuration, these pin are unused. The Mode pins have a weak pull-up resistor turned on during configuration. With the Mode pins High, Slave Serial mode is selected, which is the most popular configuration mode. Therefore, for the most common configuration mode, the Mode pins can be left unconnected. If the Master Serial mode is desired, the MODE/M0 pin should be connected directly to GND, or through a pull-down resistor of 1 KΩ or less.

During configuration, some of the I/O pins are used temporarily for the configuration process. All pins used during con-

figuration are shown in Table 14 and Table 15.

**Table 14: Pin Functions During Configuration (Spartan Family Only)**

Configuration Mode (MODE Pin)		User Operation
Slave Serial (High)	Master Serial (Low)	
MODE (I)	MODE (I)	MODE
HDC (High)	HDC (High)	I/O
$\overline{\text{LDC}}$ (Low)	$\overline{\text{LDC}}$ (Low)	I/O
$\overline{\text{INIT}}$	$\overline{\text{INIT}}$	I/O
DONE	DONE	DONE
$\overline{\text{PROGRAM}}$ (I)	$\overline{\text{PROGRAM}}$ (I)	$\overline{\text{PROGRAM}}$
CCLK (I)	CCLK (O)	CCLK (I)
DIN (I)	DIN (I)	I/O
DOUT	DOUT	SGCK4-I/O
TDI	TDI	TDI-I/O
TCK	TCK	TCK-I/O
TMS	TMS	TMS-I/O
TDO	TDO	TDO-(O)
		ALL OTHERS

- Notes:**
1. A shaded table cell represents the internal pull-up used before and during configuration.
  2. (I) represents an input; (O) represents an output.
  3.  $\overline{\text{INIT}}$  is an open-drain output during configuration.

**Table 15: Pin Functions During Configuration (Spartan-XL Family Only)**

CONFIGURATION MODE <M1:M0>			User Operation
Slave Serial [1:1]	Master Serial [1:0]	Express [0:X]	
M1 (High) (I)	M1 (High) (I)	M1(Low) (I)	M1
M0 (High) (I)	M0 (Low) (I)	M0 (I)	M0
HDC (High)	HDC (High)	HDC (High)	I/O
$\overline{\text{LDC}}$ (Low)	$\overline{\text{LDC}}$ (Low)	$\overline{\text{LDC}}$ (Low)	I/O
$\overline{\text{INIT}}$	$\overline{\text{INIT}}$	$\overline{\text{INIT}}$	I/O
DONE	DONE	DONE	DONE
$\overline{\text{PROGRAM}}$ (I)	$\overline{\text{PROGRAM}}$ (I)	$\overline{\text{PROGRAM}}$ (I)	$\overline{\text{PROGRAM}}$
CCLK (I)	CCLK (O)	CCLK (I)	CCLK (I)
		DATA 7 (I)	I/O
		DATA 6 (I)	I/O
		DATA 5 (I)	I/O
		DATA 4 (I)	I/O
		DATA 3 (I)	I/O
		DATA 2 (I)	I/O
		DATA 1 (I)	I/O
DIN (I)	DIN (I)	DATA 0 (I)	I/O
DOUT	DOUT	DOUT	GCK6-I/O
TDI	TDI	TDI	TDI-I/O
TCK	TCK	TCK	TCK-I/O
TMS	TMS	TMS	TMS-I/O
TDO	TDO	TDO	TDO-(O)
		CS1	I/O
			ALL OTHERS

- Notes:**
1. A shaded table cell represents the internal pull-up used before and during configuration.
  2. (I) represents an input; (O) represents an output.
  3.  $\overline{\text{INIT}}$  is an open-drain output during configuration.

### Master Serial Mode

The Master serial mode uses an internal oscillator to generate a Configuration Clock (CCLK) for driving potential slave devices and the Xilinx serial-configuration PROM (SPROM). The CCLK speed is selectable as either 1 MHz (default) or 8 MHz. Configuration always starts at the default slow frequency, then can switch to the higher frequency during the first frame. Frequency tolerance is -50% to +25%.

In Master Serial mode, the CCLK output of the device drives a Xilinx SPROM that feeds the FPGA DIN input. Each rising edge of the CCLK output increments the Serial PROM internal address counter. The next data bit is put on the SPROM data output, connected to the FPGA DIN pin. The FPGA accepts this data on the subsequent rising CCLK edge.

When used in a daisy-chain configuration the Master Serial FPGA is placed as the first device in the chain and is referred to as the lead FPGA. The lead FPGA presents the preamble data, and all data that overflows the lead device, on its DOUT pin. There is an internal pipeline delay of 1.5 CCLK periods, which means that DOUT changes on the

falling CCLK edge, and the next FPGA in the daisy chain accepts data on the subsequent rising CCLK edge. See the timing diagram in Figure 24.

In the bitstream generation software, the user can specify Fast Configuration Rate, which, starting several bits into the first frame, increases the CCLK frequency by a factor of eight. For actual timing values please refer to the specification section. Be sure that the serial PROM and slaves are fast enough to support this data rate. Earlier families such as the XC3000 series do not support the Fast Configuration Rate option.

The SPROM CE input can be driven from either  $\overline{LDC}$  or DONE. Using  $\overline{LDC}$  avoids potential contention on the DIN pin, if this pin is configured as user I/O, but  $\overline{LDC}$  is then restricted to be a permanently High user output after configuration. Using DONE can also avoid contention on DIN, provided the Early DONE option is invoked.

Figure 25 shows a full master/slave system. The leftmost device is in Master Serial mode, all other devices in the chain are in Slave Serial mode.

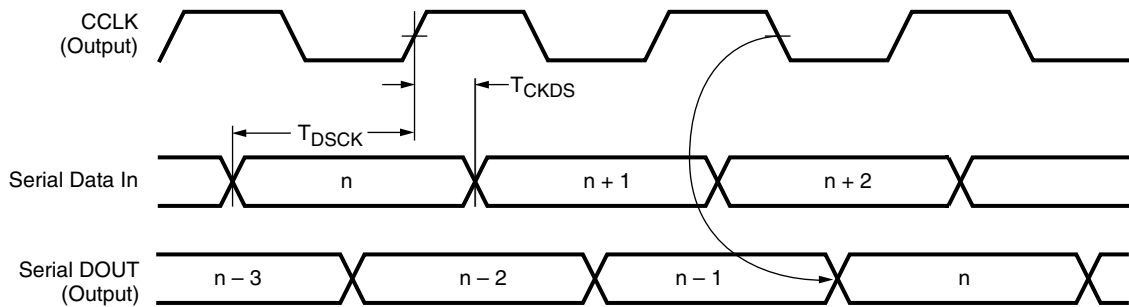

DS060\_24\_080400

	Symbol	Description	Min	Units
CCLK	T <sub>DSCK</sub>	DIN setup	20	ns
	T <sub>CKDS</sub>	DIN hold	0	ns

**Notes:**

1. At power-up, V<sub>CC</sub> must rise from 2.0V to V<sub>CC</sub> min in less than 25 ms, otherwise delay configuration by pulling PROGRAM Low until V<sub>CC</sub> is valid.
2. Master Serial mode timing is based on testing in slave mode.

Figure 24: Master Serial Mode Programming Switching Characteristics

### Slave Serial Mode

In Slave Serial mode, the FPGA receives serial configuration data on the rising edge of CCLK and, after loading its configuration, passes additional data out, resynchronized on the next falling edge of CCLK.

In this mode, an external signal drives the CCLK input of the FPGA (most often from a Master Serial device). The serial configuration bitstream must be available at the DIN input of the lead FPGA a short setup time before each rising CCLK edge.

The lead FPGA then presents the preamble data—and all data that overflows the lead device—on its DOUT pin. There is an internal delay of 0.5 CCLK periods, which means that DOUT changes on the falling CCLK edge, and the next FPGA in the daisy chain accepts data on the subsequent rising CCLK edge.

Figure 25 shows a full master/slave system. A Spartan/XL device in Slave Serial mode should be connected as shown in the third device from the left.



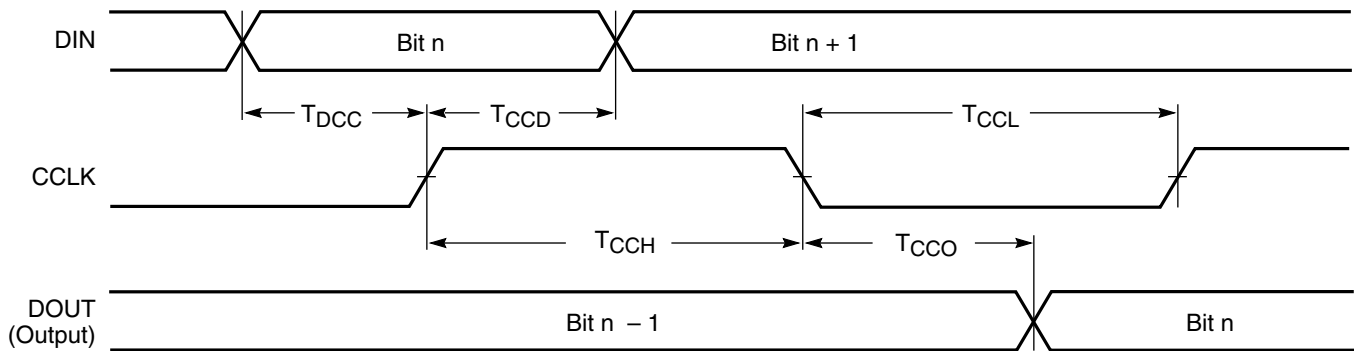

DS060\_26\_080400

Symbol		Description	Min	Max	Units
$T_{DCC}$	CCLK	DIN setup	20	-	ns
$T_{CCD}$		DIN hold	0	-	ns
$T_{CCO}$		DIN to DOUT	-	30	ns
$T_{CCH}$		High time	40	-	ns
$T_{CCL}$		Low time	40	-	ns
$F_{CC}$		Frequency	-	12.5	MHz

**Notes:**

1. Configuration must be delayed until the  $\overline{INIT}$  pins of all daisy-chained FPGAs are High.

Figure 26: Slave Serial Mode Programming Switching Characteristics

**Express Mode (Spartan-XL Family Only)**

Express mode is similar to Slave Serial mode, except that data is processed one byte per CCLK cycle instead of one bit per CCLK cycle. An external source is used to drive CCLK, while byte-wide data is loaded directly into the configuration data shift registers (Figure 27). A CCLK frequency of 1 MHz is equivalent to a 8 MHz serial rate, because eight bits of configuration data are loaded per CCLK cycle. Express mode does not support CRC error checking, but does support constant-field error checking. A length count is not used in Express mode.

Express mode must be specified as an option to the development system. The Express mode bitstream is not compatible with the other configuration modes (see Table 16, page 32.) Express mode is selected by a <0X> on the Mode pins (M1, M0).

The first byte of parallel configuration data must be available at the D inputs of the FPGA a short setup time before the second rising CCLK edge. Subsequent data bytes are clocked in on each consecutive rising CCLK edge (Figure 28).

**Pseudo Daisy Chain**

Multiple devices with different configurations can be configured in a pseudo daisy chain provided that all of the devices

are in Express mode. Concatenated bitstreams are used to configure the chain of Express mode devices so that each device receives a separate header. CCLK pins are tied together and D0-D7 pins are tied together for all devices along the chain. A status signal is passed from DOUT to CS1 of successive devices along the chain. Frame data is accepted only when CS1 is High and the device's configuration memory is not already full. The lead device in the chain has its CS1 input tied High (or floating, since there is an internal pull-up). The status pin DOUT is pulled Low after the header is received, and remains Low until the device's configuration memory is full. DOUT is then pulled High to signal the next device in the chain to accept the next header and configuration data on the D0-D7 bus.

The DONE pins of all devices in the chain should be tied together, with one or more active internal pull-ups. If a large number of devices are included in the chain, deactivate some of the internal pull-ups, since the Low-driving DONE pin of the last device in the chain must sink the current from all pull-ups in the chain. The DONE pull-up is activated by default. It can be deactivated using a development system option.

The requirement that all DONE pins in a daisy chain be wired together applies only to Express mode, and only if all devices in the chain are to become active simultaneously. All Spartan-XL devices in Express mode are synchronized

to the DONE pin. User I/Os for each device become active after the DONE pin for that device goes High. (The exact timing is determined by development system options.) Since the DONE pin is open-drain and does not drive a High value, tying the DONE pins of all devices together prevents all devices in the chain from going High until the last device

in the chain has completed its configuration cycle. If the DONE pin of a device is left unconnected, the device becomes active as soon as that device has been configured. Only devices supporting Express mode can be used to form an Express mode daisy chain.

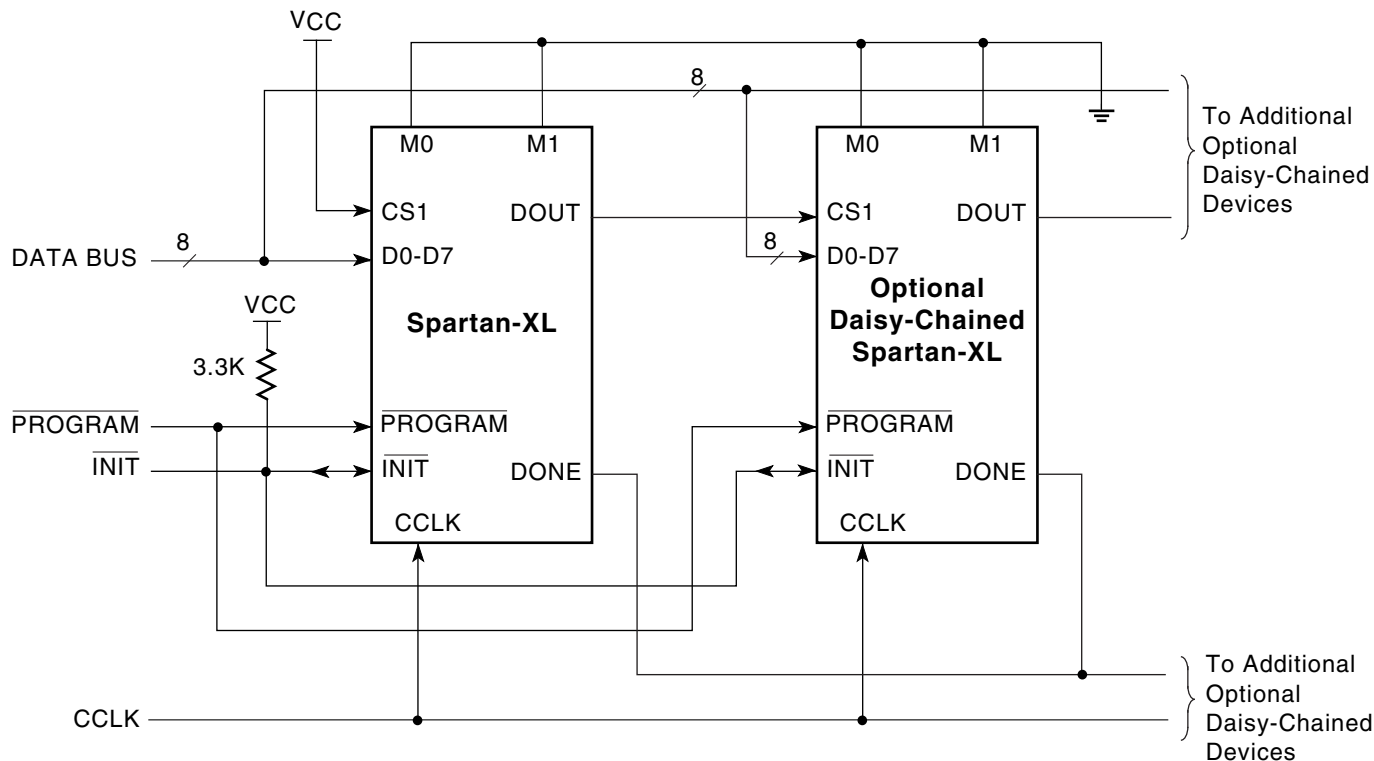

DS060\_27\_080400

Figure 27: Express Mode Circuit Diagram



DS060\_28\_080400

Symbol		Description	Min	Max	Units
$T_{IC}$	CCLK	$\overline{INIT}$ (High) setup time	5	-	$\mu s$
$T_{DC}$		D0-D7 setup time	20	-	ns
$T_{CD}$		D0-D7 hold time	0	-	ns
$T_{CCH}$		CCLK High time	45	-	ns
$T_{CCL}$		CCLK Low time	45	-	ns
$F_{CC}$		CCLK Frequency	-	10	MHz

**Notes:**

1. If not driven by the preceding DOUT, CS1 *must* remain High until the device is fully configured.

Figure 28: Express Mode Programming Switching Characteristics

### Setting CCLK Frequency

In Master mode, CCLK can be generated in either of two frequencies. In the default slow mode, the frequency ranges from 0.5 MHz to 1.25 MHz for Spartan/XL devices. In fast CCLK mode, the frequency ranges from 4 MHz to 10 MHz for Spartan/XL devices. The frequency is changed to fast by an option when running the bitstream generation software.

### Data Stream Format

The data stream ("bitstream") format is identical for both serial configuration modes, but different for the Spartan-XL family Express mode. In Express mode, the device becomes active when DONE goes High, therefore no length count is required. Additionally, CRC error checking is not supported in Express mode. The data stream format is shown in Table 16. Bit-serial data is read from left to right.

Express mode data is shown with D0 at the left and D7 at the right.

The configuration data stream begins with a string of eight ones, a preamble code, followed by a 24-bit length count and a separator field of ones (or 24 fill bits, in Spartan-XL family Express mode). This header is followed by the actual configuration data in frames. The length and number of frames depends on the device type (see Table 17). Each frame begins with a start field and ends with an error check. In serial modes, a postamble code is required to signal the end of data for a single device. In all cases, additional start-up bytes of data are required to provide four clocks for the startup sequence at the end of configuration. Long daisy chains require additional startup bytes to shift the last data through the chain. All start-up bytes are "don't cares".

Table 16: Spartan/XL Data Stream Formats

Data Type	Serial Modes (D0...)	Express Mode (D0-D7) (Spartan-XL only)
Fill Byte	11111111b	FFFFh
Preamble Code	0010b	11110010b
Length Count	COUNT[23:0]	COUNT[23:0] <sup>(1)</sup>
Fill Bits	1111b	-
Field Check Code	-	11010010b
Start Field	0b	11111110b <sup>(2)</sup>
Data Frame	DATA[n-1:0]	DATA[n-1:0]
CRC or Constant Field Check	xxxx (CRC) or 0110b	11010010b
Extend Write Cycle	-	FFD2FFFFFFh
Postamble	01111111b	-
Start-Up Bytes <sup>(3)</sup>	FFh	FFFFFFFFFFFFFFh

**Legend:**

Unshaded	Once per bitstream
Light	Once per data frame
Dark	Once per device

**Notes:**

1. Not used by configuration logic.
2. 11111111b for XCS40XL only.
3. Development system may add more start-up bytes.

A selection of CRC or non-CRC error checking is allowed by the bitstream generation software. The Spartan-XL family Express mode only supports non-CRC error checking. The non-CRC error checking tests for a designated end-of-frame field for each frame. For CRC error checking, the software calculates a running CRC and inserts a unique four-bit partial check at the end of each frame. The 11-bit CRC check of the last frame of an FPGA includes the last seven data bits.

Detection of an error results in the suspension of data loading before DONE goes High, and the pulling down of the  $\overline{\text{INIT}}$  pin. In Master serial mode, CCLK continues to operate externally. The user must detect  $\overline{\text{INIT}}$  and initialize a new configuration by pulsing the PROGRAM pin Low or cycling V<sub>CC</sub>.

**Cyclic Redundancy Check (CRC) for Configuration and Readback**

The Cyclic Redundancy Check is a method of error detection in data transmission applications. Generally, the transmitting system performs a calculation on the serial bitstream. The result of this calculation is tagged onto the data stream as additional check bits. The receiving system performs an identical calculation on the bitstream and compares the result with the received checksum.

Each data frame of the configuration bitstream has four error bits at the end, as shown in Table 16. If a frame data error is detected during the loading of the FPGA, the configuration process with a potentially corrupted bitstream is terminated. The FPGA pulls the  $\overline{\text{INIT}}$  pin Low and goes into a Wait state.

Table 17: Spartan/XL Program Data

Device	XCS05		XCS10		XCS20		XCS30		XCS40	
Max System Gates	5,000		10,000		20,000		30,000		40,000	
CLBs (Row x Col.)	100 (10 x 10)		196 (14 x 14)		400 (20 x 20)		576 (24 x 24)		784 (28 x 28)	
I/Os	80		112		160		192		205 <sup>(4)</sup>	
Part Number	XCS05	XCS05XL	XCS10	XCS10XL	XCS20	XCS20XL	XCS30	XCS30XL	XCS40	XCS40XL
Supply Voltage	5V	3.3V	5V	3.3V	5V	3.3V	5V	3.3V	5V	3.3V
Bits per Frame	126	127	166	167	226	227	266	267	306	307
Frames	428	429	572	573	788	789	932	933	1,076	1,077
Program Data	53,936	54,491	94,960	95,699	178,096	179,111	247,920	249,119	329,264	330,647
PROM Size (bits)	53,984	54,544	95,008	95,752	178,144	179,160	247,968	249,168	329,312	330,696
Express Mode PROM Size (bits)	-	79,072	-	128,488	-	221,056	-	298,696	-	387,856

**Notes:**

- Bits per Frame = (10 x number of rows) + 7 for the top + 13 for the bottom + 1 + 1 start bit + 4 error check bits (+1 for Spartan-XL device)  
 Number of Frames = (36 x number of columns) + 26 for the left edge + 41 for the right edge + 1 (+ 1 for Spartan-XL device)  
 Program Data = (Bits per Frame x Number of Frames) + 8 postamble bits  
 PROM Size = Program Data + 40 (header) + 8, rounded up to the nearest byte
- The user can add more "1" bits as leading dummy bits in the header, or, if CRC = off, as trailing dummy bits at the end of any frame, following the four error check bits. However, the Length Count value **must** be adjusted for all such extra "one" bits, even for extra leading ones at the beginning of the header.
- Express mode adds 57 (XCS05XL, XCS10XL), or 53 (XCS20XL, XCS30XL, XCS40XL) bits per frame, + additional start-up bits.
- XCS40XL provided 224 max I/O in CS280 package discontinued by [PDN2004-01](#).

During Readback, 11 bits of the 16-bit checksum are added to the end of the Readback data stream. The checksum is computed using the CRC-16 CCITT polynomial, as shown in [Figure 29](#). The checksum consists of the 11 most significant bits of the 16-bit code. A change in the checksum indicates a change in the Readback bitstream. A comparison to a previous checksum is meaningful only if the readback

data is independent of the current device state. CLB outputs should not be included (Readback Capture option not used), and if RAM is present, the RAM content must be unchanged.

Statistically, one error out of 2048 might go undetected.

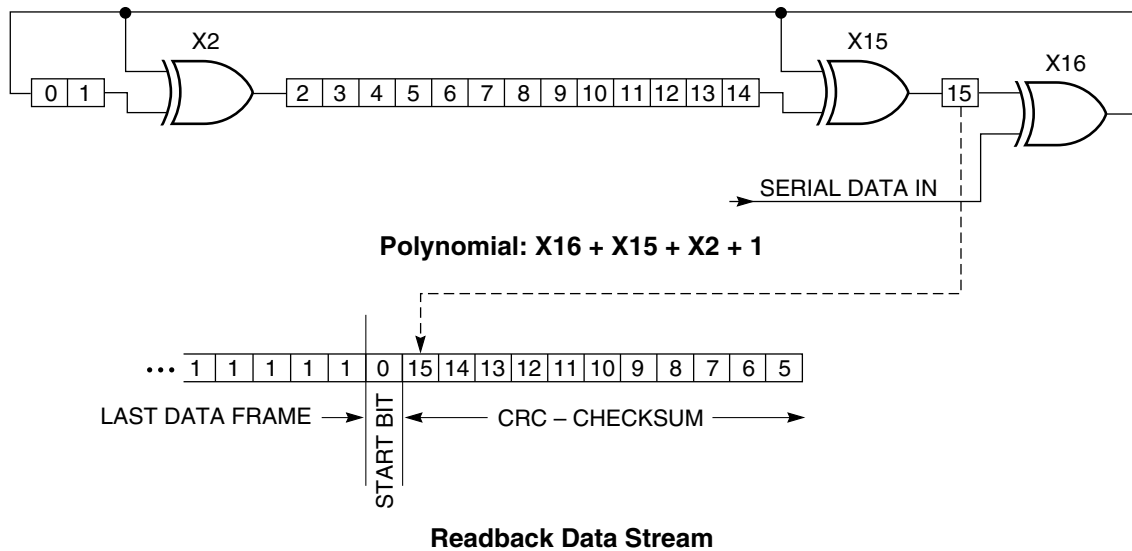

DS060\_29\_080400

Figure 29: Circuit for Generating CRC-16

## Configuration Sequence

There are four major steps in the Spartan/XL FPGA power-up configuration sequence.

- Configuration Memory Clear
- Initialization
- Configuration
- Start-up

The full process is illustrated in Figure 30.

### Configuration Memory Clear

When power is first applied or is reapplied to an FPGA, an internal circuit forces initialization of the configuration logic. When  $V_{CC}$  reaches an operational level, and the circuit passes the write and read test of a sample pair of configuration bits, a time delay is started. This time delay is nominally 16 ms. The delay is four times as long when in Master Serial Mode to allow ample time for all slaves to reach a stable  $V_{CC}$ . When all  $\overline{INIT}$  pins are tied together, as recommended, the longest delay takes precedence. Therefore, devices with different time delays can easily be mixed and matched in a daisy chain.

This delay is applied only on power-up. It is not applied when reconfiguring an FPGA by pulsing the  $\overline{PROGRAM}$  pin

Low. During this time delay, or as long as the  $\overline{PROGRAM}$  input is asserted, the configuration logic is held in a Configuration Memory Clear state. The configuration-memory frames are consecutively initialized, using the internal oscillator.

At the end of each complete pass through the frame addressing, the power-on time-out delay circuitry and the level of the  $\overline{PROGRAM}$  pin are tested. If neither is asserted, the logic initiates one additional clearing of the configuration frames and then tests the  $\overline{INIT}$  input.

### Initialization

During initialization and configuration, user pins  $\overline{HDC}$ ,  $\overline{LDC}$ ,  $\overline{INIT}$  and  $\overline{DONE}$  provide status outputs for the system interface. The outputs  $\overline{LDC}$ ,  $\overline{INIT}$  and  $\overline{DONE}$  are held Low and  $\overline{HDC}$  is held High starting at the initial application of power.

The open drain  $\overline{INIT}$  pin is released after the final initialization pass through the frame addresses. There is a deliberate delay before a Master-mode device recognizes an inactive  $\overline{INIT}$ . Two internal clocks after the  $\overline{INIT}$  pin is recognized as High, the device samples the  $\overline{MODE}$  pin to determine the configuration mode. The appropriate interface lines become active and the configuration preamble and data can be loaded.



Figure 30: Power-up Configuration Sequence

### Configuration

The 0010 preamble code indicates that the following 24 bits represent the length count for serial modes. The length count is the total number of configuration clocks needed to load the complete configuration data. (Four additional configuration clocks are required to complete the configuration process, as discussed below.) After the preamble and the length count have been passed through to any device in the daisy chain, its DOUT is held High to prevent frame start bits from reaching any daisy-chained devices. In Spartan-XL family Express mode, the length count bits are ignored, and DOUT is held Low, to disable the next device in the pseudo daisy chain.

A specific configuration bit, early in the first frame of a master device, controls the configuration-clock rate and can increase it by a factor of eight. Therefore, if a fast configuration clock is selected by the bitstream, the slower clock rate is used until this configuration bit is detected.

Each frame has a start field followed by the frame-configuration data bits and a frame error field. If a frame data error is detected, the FPGA halts loading, and signals the error by pulling the open-drain  $\overline{\text{INIT}}$  pin Low. After all configuration frames have been loaded into an FPGA using a serial mode, DOUT again follows the input data so that the remaining data is passed on to the next device. In Spartan-XL family Express mode, when the first device is fully programmed, DOUT goes High to enable the next device in the chain.

### Delaying Configuration After Power-Up

There are two methods of delaying configuration after power-up: put a logic Low on the  $\overline{\text{PROGRAM}}$  input, or pull the bidirectional  $\overline{\text{INIT}}$  pin Low, using an open-collector (open-drain) driver. (See Figure 30.)

A Low on the  $\overline{\text{PROGRAM}}$  input is the more radical approach, and is recommended when the power-supply rise time is excessive or poorly defined. As long as  $\overline{\text{PROGRAM}}$  is Low, the FPGA keeps clearing its configuration memory. When  $\overline{\text{PROGRAM}}$  goes High, the configuration memory is cleared one more time, followed by the beginning of configuration, provided the  $\overline{\text{INIT}}$  input is not externally held Low. Note that a Low on the  $\overline{\text{PROGRAM}}$  input automatically forces a Low on the  $\overline{\text{INIT}}$  output. The Spartan/XL FPGA  $\overline{\text{PROGRAM}}$  pin has a permanent weak pull-up.

Avoid holding  $\overline{\text{PROGRAM}}$  Low for more than 500  $\mu\text{s}$ . The 500  $\mu\text{s}$  maximum limit is only a recommendation, not a requirement. The only effect of holding  $\overline{\text{PROGRAM}}$  Low for more than 500  $\mu\text{s}$  is an increase in current, measured at about 40 mA in the XCS40XL. This increased current cannot damage the device. This applies only during reconfiguration, not during power-up. The  $\overline{\text{INIT}}$  pin can also be held Low to delay reconfiguration, and the same characteristics apply as for the  $\overline{\text{PROGRAM}}$  pin.

Using an open-collector or open-drain driver to hold  $\overline{\text{INIT}}$  Low before the beginning of configuration causes the FPGA

to wait after completing the configuration memory clear operation. When  $\overline{\text{INIT}}$  is no longer held Low externally, the device determines its configuration mode by capturing the state of the Mode pins, and is ready to start the configuration process. A master device waits up to an additional 300  $\mu\text{s}$  to make sure that any slaves in the optional daisy chain have seen that  $\overline{\text{INIT}}$  is High.

For more details on Configuration, refer to the Xilinx Application Note "FPGA Configuration Guidelines" (XAPP090).

### Start-Up

Start-up is the transition from the configuration process to the intended user operation. This transition involves a change from one clock source to another, and a change from interfacing parallel or serial configuration data where most outputs are 3-stated, to normal operation with I/O pins active in the user system. Start-up must make sure that the user logic 'wakes up' gracefully, that the outputs become active without causing contention with the configuration signals, and that the internal flip-flops are released from the Global Set/Reset (GSR) at the right time.

#### Start-Up Initiation

Two conditions have to be met in order for the start-up sequence to begin:

- The chip's internal memory must be full, and
- The configuration length count must be met, exactly.

In all configuration modes except Express mode, Spartan/XL devices read the expected length count from the bitstream and store it in an internal register. The length count varies according to the number of devices and the composition of CCLKs during configuration.

In Express mode, there is no length count. The start-up sequence for each device begins when the device has received its quota of configuration data. Wiring the DONE pins of several devices together delays start-up of all devices until all are fully configured.

#### Start-Up Events

The device can be programmed to control three start-up events.

- The release of the open-drain DONE output
- The termination of the Global Three-State and the change of configuration-related pins to the user function, activating all IOBs.
- The termination of the Global Set/Reset initialization of all CLB and IOB storage elements.

Figure 31 describes start-up timing in detail. The three events — DONE going High, the internal GSR being de-activated, and the user I/O going active — can all occur in any arbitrary sequence. This relative timing is selected by options in the bitstream generation software. Heavy lines in Figure 31 show the default timing. The thin lines indicate all other possible timing options. The start-up logic must be clocked until the "F" (Finished) state is reached.

The default option, and the most practical one, is for DONE to go High first, disconnecting the configuration data source and avoiding any contention when the I/Os become active one clock later. GSR is then released another clock period later to make sure that user operation starts from stable internal conditions. This is the most common sequence, shown with heavy lines in Figure 31, but the designer can modify it to meet particular requirements.

#### Start-Up Clock

Normally, the start-up sequence is controlled by the internal device oscillator (CCLK), which is asynchronous to the system clock. As a configuration option, they can be triggered by an on-chip user net called UCLK. This user net can be accessed by placing the STARTUP library symbol, and the start-up modes are known as UCLK\_NOSYNC or UCLK\_SYNC. This allows the device to wake up in synchronism with the user system.

#### DONE Pin

Note that DONE is an open-drain output and does not go High unless an internal pull-up is activated or an external pull-up is attached. The internal pull-up is activated as the default by the bitstream generation software.

The DONE pin can also be wire-ANDed with DONE pins of other FPGAs or with other external signals, and can then be used as input to the start-up control logic. This is called "Start-up Timing Synchronous to Done In" and is selected by either CCLK\_SYNC or UCLK\_SYNC. When DONE is not used as an input, the operation is called "Start-up Timing Not Synchronous to DONE In," and is selected by either CCLK\_NOSYNC or UCLK\_NOSYNC. Express mode configuration always uses either CCLK\_SYNC or UCLK\_SYNC timing, while the other configuration modes can use any of the four timing sequences.

When the UCLK\_SYNC option is enabled, the user can externally hold the open-drain DONE output Low, and thus stall all further progress in the start-up sequence until DONE is released and has gone High. This option can be used to force synchronization of several FPGAs to a common user clock, or to guarantee that all devices are successfully configured before any I/Os go active.



DS060\_39\_082801

Figure 31: Start-up Timing

### Configuration Through the Boundary Scan Pins

Spartan/XL devices can be configured through the boundary scan pins. The basic procedure is as follows:

- Power up the FPGA with  $\overline{\text{INIT}}$  held Low (or drive the PROGRAM pin Low for more than 300 ns followed by a High while holding  $\overline{\text{INIT}}$  Low). Holding  $\overline{\text{INIT}}$  Low allows enough time to issue the CONFIG command to the FPGA. The pin can be used as I/O after configuration if a resistor is used to hold  $\overline{\text{INIT}}$  Low.
- Issue the CONFIG command to the TMS input.

- Wait for  $\overline{\text{INIT}}$  to go High.
- Sequence the boundary scan Test Access Port to the SHIFT-DR state.
- Toggle TCK to clock data into TDI pin.

The user must account for all TCK clock cycles after  $\overline{\text{INIT}}$  goes High, as all of these cycles affect the Length Count compare.

For more detailed information, refer to the Xilinx application note, "Boundary Scan in FPGA Devices." This application note applies to Spartan and Spartan-XL devices.

## Readback

The user can read back the content of configuration memory and the level of certain internal nodes without interfering with the normal operation of the device.

Readback not only reports the downloaded configuration bits, but can also include the present state of the device, represented by the content of all flip-flops and latches in CLBs and IOBs, as well as the content of function generators used as RAMs.

Although readback can be performed while the device is operating, for best results and to freeze a known capture state, it is recommended that the clock inputs be stopped until readback is complete.

Readback of Spartan-XL family Express mode bitstreams results in data that does not resemble the original bitstream, because the bitstream format differs from other modes.

Spartan/XL FPGA Readback does not use any dedicated pins, but uses four internal nets (RDBK.TRIG, RDBK.DATA, RDBK.RIP and RDBK.CLK) that can be routed to any IOB. To access the internal Readback signals, instantiate the READBACK library symbol and attach the appropriate pad symbols, as shown in [Figure 32](#).

After Readback has been initiated by a Low-to-High transition on RDBK.TRIG, the RDBK.RIP (Read In Progress) output goes High on the next rising edge of RDBK.CLK. Subsequent rising edges of this clock shift out Readback data on the RDBK.DATA net.

Readback data does not include the preamble, but starts with five dummy bits (all High) followed by the Start bit (Low)

of the first frame. The first two data bits of the first frame are always High.

Each frame ends with four error check bits. They are read back as High. The last seven bits of the last frame are also read back as High. An additional Start bit (Low) and an 11-bit Cyclic Redundancy Check (CRC) signature follow, before RDBK.RIP returns Low.

### Readback Options

Readback options are: Readback Capture, Readback Abort, and Clock Select. They are set with the bitstream generation software.

### Readback Capture

When the Readback Capture option is selected, the data stream includes sampled values of CLB and IOB signals. The rising edge of RDBK.TRIG latches the inverted values of the four CLB outputs, the IOB output flip-flops and the input signals I1 and I2. Note that while the bits describing configuration (interconnect, function generators, and RAM content) are *not* inverted, the CLB and IOB output signals *are* inverted. RDBK.TRIG is located in the lower-left corner of the device.

When the Readback Capture option is not selected, the values of the capture bits reflect the configuration data originally written to those memory locations. If the RAM capability of the CLBs is used, RAM data are available in Readback, since they directly overwrite the F and G function-table configuration of the CLB.



Figure 32: Readback Example

### Readback Abort

When the Readback Abort option is selected, a High-to-Low transition on RDBK.TRIG terminates the Readback operation and prepares the logic to accept another trigger.

After an aborted Readback, additional clocks (up to one Readback clock per configuration frame) may be required to re-initialize the control logic. The status of Readback is indicated by the output control net RDBK.RIP. RDBK.RIP is High whenever a readback is in progress.

### Clock Select

CCLK is the default clock. However, the user can insert another clock on RDBK.CLK. Readback control and data are clocked on rising edges of RDBK.CLK. If Readback must be inhibited for security reasons, the Readback control nets are simply not connected. RDBK.CLK is located in the lower right chip corner.

### Violating the Maximum High and Low Time Specification for the Readback Clock

The Readback clock has a maximum High and Low time specification. In some cases, this specification cannot be

met. For example, if a processor is controlling Readback, an interrupt may force it to stop in the middle of a readback. This necessitates stopping the clock, and thus violating the specification.

The specification is mandatory only on clocking data at the end of a frame prior to the next start bit. The transfer mechanism will load the data to a shift register during the last six clock cycles of the frame, prior to the start bit of the following frame. This loading process is dynamic, and is the source of the maximum High and Low time requirements.

Therefore, the specification only applies to the six clock cycles prior to and including any start bit, including the clocks before the first start bit in the Readback data stream. At other times, the frame data is already in the register and the register is not dynamic. Thus, it can be shifted out just like a regular shift register.

The user must precisely calculate the location of the Readback data relative to the frame. The system must keep track of the position within a data frame, and disable interrupts before frame boundaries. Frame lengths and data formats are listed in [Table 16](#) and [Table 17](#).

## Readback Switching Characteristics Guidelines

The following guidelines reflect worst-case values over the recommended operating conditions.



DS060\_32\_080400

Figure 33: Spartan and Spartan-XL Readback Timing Diagram

### Spartan and Spartan-XL Readback Switching Characteristics

Symbol		Description	Min	Max	Units
$T_{RTRC}$	rdbk.TRIG	rdbk.TRIG setup to initiate and abort Readback	200	-	ns
$T_{RCRT}$		rdbk.TRIG hold to initiate and abort Readback	50	-	ns
$T_{RCRD}$	rdclk.I	rdbk.DATA delay	-	250	ns
$T_{RCRR}$		rdbk.RIP delay	-	250	ns
$T_{RCH}$		High time	250	500	ns
$T_{RCL}$		Low time	250	500	ns

**Notes:**

1. Timing parameters apply to all speed grades.
2. If rdbk.TRIG is High prior to Finished, Finished will trigger the first Readback.

## Configuration Switching Characteristics



DS060\_33\_080400

### Master Mode

Symbol	Description	Min	Max	Units
$T_{POR}$	Power-on reset	40	130	ms
$T_{PI}$	Program Latency	30	200	$\mu$ s per CLB column
$T_{ICCK}$	CCLK (output) delay	40	250	$\mu$ s
$T_{CCLK}$	CCLK (output) period, slow	640	2000	ns
$T_{CCLK}$	CCLK (output) period, fast	100	250	ns

### Slave Mode

Symbol	Description	Min	Max	Units
$T_{POR}$	Power-on reset	10	33	ms
$T_{PI}$	Program latency	30	200	$\mu$ s per CLB column
$T_{ICCK}$	CCLK (input) delay (required)	4	-	$\mu$ s
$T_{CCLK}$	CCLK (input) period (required)	80	-	ns

## Spartan Family Detailed Specifications

### Definition of Terms

In the following tables, some specifications may be designated as Advance or Preliminary. These terms are defined as follows:

**Advance:** Initial estimates based on simulation and/or extrapolation from other speed grades, devices, or families. Values are subject to change. Use as estimates, not for production.

**Preliminary:** Based on preliminary characterization. Further changes are not expected.

**Unmarked:** Specifications not identified as either Advance or Preliminary are to be considered Final.

Notwithstanding the definition of the above terms, all specifications are subject to change without notice.

Except for pin-to-pin input and output parameters, the AC parameter delay specifications included in this document are derived from measuring internal test patterns. All specifications are representative of worst-case supply voltage and junction temperature conditions. The parameters included are common to popular designs and typical applications.

### Spartan Family Absolute Maximum Ratings<sup>(1)</sup>

Symbol	Description	Value	Units
$V_{CC}$	Supply voltage relative to GND	-0.5 to +7.0	V
$V_{IN}$	Input voltage relative to GND <sup>(2,3)</sup>	-0.5 to $V_{CC} + 0.5$	V
$V_{TS}$	Voltage applied to 3-state output <sup>(2,3)</sup>	-0.5 to $V_{CC} + 0.5$	V
$T_{STG}$	Storage temperature (ambient)	-65 to +150	°C
$T_J$	Junction temperature	Plastic packages +125	°C

#### Notes:

- Stresses beyond those listed under Absolute Maximum Ratings may cause permanent damage to the device. These are stress ratings only, and functional operation of the device at these or any other conditions beyond those listed under Operating Conditions is not implied. Exposure to Absolute Maximum Ratings conditions for extended periods of time may affect device reliability.
- Maximum DC overshoot (above  $V_{CC}$ ) or undershoot (below GND) must be limited to either 0.5V or 10 mA, whichever is easier to achieve.
- Maximum AC (during transitions) conditions are as follows; the device pins may undershoot to -2.0V or overshoot to +7.0V, provided this overshoot or undershoot lasts no more than 11 ns with a forcing current no greater than 100 mA.
- For soldering guidelines, see the Package Information on the Xilinx website.

### Spartan Family Recommended Operating Conditions

Symbol	Description		Min	Max	Units
$V_{CC}$	Supply voltage relative to GND, $T_J = 0^\circ\text{C}$ to $+85^\circ\text{C}$	Commercial	4.75	5.25	V
	Supply voltage relative to GND, $T_J = -40^\circ\text{C}$ to $+100^\circ\text{C}$ <sup>(1)</sup>	Industrial	4.5	5.5	V
$V_{IH}$	High-level input voltage <sup>(2)</sup>	TTL inputs	2.0	$V_{CC}$	V
		CMOS inputs	70%	100%	$V_{CC}$
$V_{IL}$	Low-level input voltage <sup>(2)</sup>	TTL inputs	0	0.8	V
		CMOS inputs	0	20%	$V_{CC}$
$T_{IN}$	Input signal transition time		-	250	ns

#### Notes:

- At junction temperatures above those listed as Recommended Operating Conditions, all delay parameters increase by 0.35% per °C.
- Input and output measurement thresholds are: 1.5V for TTL and 2.5V for CMOS.

## Spartan Family DC Characteristics Over Operating Conditions

Symbol	Description	Min	Max	Units	
V <sub>OH</sub>	High-level output voltage @ I <sub>OH</sub> = -4.0 mA, V <sub>CC</sub> min	TTL outputs	2.4	-	V
	High-level output voltage @ I <sub>OH</sub> = -1.0 mA, V <sub>CC</sub> min	CMOS outputs	V <sub>CC</sub> - 0.5	-	V
V <sub>OL</sub>	Low-level output voltage @ I <sub>OL</sub> = 12.0 mA, V <sub>CC</sub> min <sup>(1)</sup>	TTL outputs	-	0.4	V
		CMOS outputs	-	0.4	V
V <sub>DR</sub>	Data retention supply voltage (below which configuration data may be lost)	3.0	-	V	
I <sub>CCO</sub>	Quiescent FPGA supply current <sup>(2)</sup>	Commercial	-	3.0	mA
		Industrial	-	6.0	mA
I <sub>L</sub>	Input or output leakage current	-10	+10	μA	
C <sub>IN</sub>	Input capacitance (sample tested)	-	10	pF	
I <sub>RPU</sub>	Pad pull-up (when selected) @ V <sub>IN</sub> = 0V (sample tested)	0.02	0.25	mA	
I <sub>RPD</sub>	Pad pull-down (when selected) @ V <sub>IN</sub> = 5V (sample tested)	0.02	-	mA	

## Notes:

- With 50% of the outputs simultaneously sinking 12 mA, up to a maximum of 64 pins.
- With no output current loads, no active input pull-up resistors, all package pins at V<sub>CC</sub> or GND, and the FPGA configured with a Tie option.

## Spartan Family Global Buffer Switching Characteristic Guidelines

All devices are 100% functionally tested. Internal timing parameters are derived from measuring internal test patterns. Listed below are representative values where one global clock input drives one vertical clock line in each accessible column, and where all accessible IOB and CLB flip-flops are clocked by the global clock net.

When fewer vertical clock lines are connected, the clock distribution is faster; when multiple clock lines per column are driven from the same global clock, the delay is longer. For

more specific, more precise, and worst-case guaranteed data, reflecting the actual routing structure, use the values provided by the static timing analyzer (TRCE in the Xilinx Development System) and back-annotated to the simulation netlist. These path delays, provided as a guideline, have been extracted from the static timing analyzer report. All timing parameters assume worst-case operating conditions (supply voltage and junction temperature).

Symbol	Description	Device	Speed Grade		Units
			-4	-3	
			Max	Max	
T <sub>PG</sub>	From pad through Primary buffer, to any clock K	XCS05	2.0	4.0	ns
		XCS10	2.4	4.3	ns
		XCS20	2.8	5.4	ns
		XCS30	3.2	5.8	ns
		XCS40	3.5	6.4	ns
T <sub>SG</sub>	From pad through Secondary buffer, to any clock K	XCS05	2.5	4.4	ns
		XCS10	2.9	4.7	ns
		XCS20	3.3	5.8	ns
		XCS30	3.6	6.2	ns
		XCS40	3.9	6.7	ns

## Spartan Family CLB Switching Characteristic Guidelines

All devices are 100% functionally tested. Internal timing parameters are derived from measuring internal test patterns. Listed below are representative values. For more specific, more precise, and worst-case guaranteed data, use the values reported by the static timing analyzer (TRCE

in the Xilinx Development System) and back-annotated to the simulation netlist. All timing parameters assume worst-case operating conditions (supply voltage and junction temperature). Values apply to all Spartan devices and expressed in nanoseconds unless otherwise noted.

Symbol	Description	Speed Grade				Units
		-4		-3		
		Min	Max	Min	Max	
<b>Clocks</b>						
$T_{CH}$	Clock High time	3.0	-	4.0	-	ns
$T_{CL}$	Clock Low time	3.0	-	4.0	-	ns
<b>Combinatorial Delays</b>						
$T_{ILO}$	F/G inputs to X/Y outputs	-	1.2	-	1.6	ns
$T_{IHO}$	F/G inputs via H to X/Y outputs	-	2.0	-	2.7	ns
$T_{HH1O}$	C inputs via H1 via H to X/Y outputs	-	1.7	-	2.2	ns
<b>CLB Fast Carry Logic</b>						
$T_{OPCY}$	Operand inputs (F1, F2, G1, G4) to $C_{OUT}$	-	1.7	-	2.1	ns
$T_{ASCY}$	Add/Subtract input (F3) to $C_{OUT}$	-	2.8	-	3.7	ns
$T_{INCY}$	Initialization inputs (F1, F3) to $C_{OUT}$	-	1.2	-	1.4	ns
$T_{SUM}$	$C_{IN}$ through function generators to X/Y outputs	-	2.0	-	2.6	ns
$T_{BYP}$	$C_{IN}$ to $C_{OUT}$ ; bypass function generators	-	0.5	-	0.6	ns
<b>Sequential Delays</b>						
$T_{CKO}$	Clock K to Flip-Flop outputs Q	-	2.1	-	2.8	ns
<b>Setup Time before Clock K</b>						
$T_{ICK}$	F/G inputs	1.8	-	2.4	-	ns
$T_{IHCK}$	F/G inputs via H	2.9	-	3.9	-	ns
$T_{HH1CK}$	C inputs via H1 through H	2.3	-	3.3	-	ns
$T_{DICK}$	C inputs via DIN	1.3	-	2.0	-	ns
$T_{EICK}$	C inputs via EC	2.0	-	2.6	-	ns
$T_{RCK}$	C inputs via S/R, going Low (inactive)	2.5	-	4.0	-	ns
<b>Hold Time after Clock K</b>						
	All Hold times, all devices	0.0	-	0.0	-	ns
<b>Set/Reset Direct</b>						
$T_{RPW}$	Width (High)	3.0	-	4.0	-	ns
$T_{RIO}$	Delay from C inputs via S/R, going High to Q	-	3.0	-	4.0	ns
<b>Global Set/Reset</b>						
$T_{MRW}$	Minimum GSR pulse width	11.5	-	13.5	-	ns
$T_{MRQ}$	Delay from GSR input to any Q	See <a href="#">page 50</a> for $T_{RRI}$ values per device.				
$F_{TOG}$	Toggle Frequency (MHz) (for export control purposes)	-	166	-	125	MHz

## Spartan Family CLB RAM Synchronous (Edge-Triggered) Write Operation Guidelines

All devices are 100% functionally tested. Internal timing parameters are derived from measuring internal test patterns. Listed below are representative values. For more specific, more precise, and worst-case guaranteed data, use the values reported by the static timing analyzer (TRCE

in the Xilinx Development System) and back-annotated to the simulation netlist. All timing parameters assume worst-case operating conditions (supply voltage and junction temperature). Values apply to all Spartan devices and are expressed in nanoseconds unless otherwise noted.

Symbol	Single Port RAM	Size <sup>(1)</sup>	Speed Grade				Units
			-4		-3		
			Min	Max	Min	Max	
<b>Write Operation</b>							
$T_{WCS}$	Address write cycle time (clock K period)	16x2	8.0	-	11.6	-	ns
$T_{WCTS}$		32x1	8.0	-	11.6	-	ns
$T_{WPS}$	Clock K pulse width (active edge)	16x2	4.0	-	5.8	-	ns
$T_{WPTS}$		32x1	4.0	-	5.8	-	ns
$T_{ASS}$	Address setup time before clock K	16x2	1.5	-	2.0	-	ns
$T_{ASTS}$		32x1	1.5	-	2.0	-	ns
$T_{AHS}$	Address hold time after clock K	16x2	0.0	-	0.0	-	ns
$T_{AHTS}$		32x1	0.0	-	0.0	-	ns
$T_{DSS}$	DIN setup time before clock K	16x2	1.5	-	2.7	-	ns
$T_{DSTS}$		32x1	1.5	-	1.7	-	ns
$T_{DHS}$	DIN hold time after clock K	16x2	0.0	-	0.0	-	ns
$T_{DHTS}$		32x1	0.0	-	0.0	-	ns
$T_{WSS}$	WE setup time before clock K	16x2	1.5	-	1.6	-	ns
$T_{WSTS}$		32x1	1.5	-	1.6	-	ns
$T_{WHS}$	WE hold time after clock K	16x2	0.0	-	0.0	-	ns
$T_{WHTS}$		32x1	0.0	-	0.0	-	ns
$T_{WOS}$	Data valid after clock K	16x2	-	6.5	-	7.9	ns
$T_{WOTS}$		32x1	-	7.0	-	9.3	ns
<b>Read Operation</b>							
$T_{RC}$	Address read cycle time	16x2	2.6	-	2.6	-	ns
$T_{RCT}$		32x1	3.8	-	3.8	-	ns
$T_{ILO}$	Data valid after address change (no Write Enable)	16x2	-	1.2	-	1.6	ns
$T_{IHO}$		32x1	-	2.0	-	2.7	ns
$T_{ICK}$	Address setup time before clock K	16x2	1.8	-	2.4	-	ns
$T_{IHCK}$		32x1	2.9	-	3.9	-	ns

**Notes:**

1. Timing for 16 x 1 RAM option is identical to 16 x 2 RAM timing.

## Spartan Family CLB RAM Synchronous (Edge-Triggered) Write Operation Guidelines (continued)

All devices are 100% functionally tested. Internal timing parameters are derived from measuring internal test patterns. Listed below are representative values. For more specific, more precise, and worst-case guaranteed data, use the values reported by the static timing analyzer (TRCE

in the Xilinx Development System) and back-annotated to the simulation netlist. All timing parameters assume worst-case operating conditions (supply voltage and junction temperature). Values apply to all Spartan devices and are expressed in nanoseconds unless otherwise noted.

## Dual-Port RAM Synchronous (Edge-Triggered) Write Operation Characteristics

Symbol	Dual Port RAM	Size <sup>(1)</sup>	-4		-3		Units
			Min	Max	Min	Max	
<b>Write Operation</b>							
$T_{WCDS}$	Address write cycle time (clock K period)	16x1	8.0	-	11.6	-	ns
$T_{WPDS}$	Clock K pulse width (active edge)	16x1	4.0	-	5.8	-	ns
$T_{ASDS}$	Address setup time before clock K	16x1	1.5	-	2.1	-	ns
$T_{AHDS}$	Address hold time after clock K	16x1	0	-	0	-	ns
$T_{DSDS}$	DIN setup time before clock K	16x1	1.5	-	1.6	-	ns
$T_{DHDS}$	DIN hold time after clock K	16x1	0	-	0	-	ns
$T_{WSDS}$	WE setup time before clock K	16x1	1.5	-	1.6	-	ns
$T_{WHDS}$	WE hold time after clock K	16x1	0	-	0	-	ns
$T_{WODS}$	Data valid after clock K	16x1	-	6.5	-	7.0	ns

**Notes:**

1. Read Operation timing for 16 x 1 dual-port RAM option is identical to 16 x 2 single-port RAM timing

## Spartan Family CLB RAM Synchronous (Edge-Triggered) Write Timing

### Single Port

### Dual Port

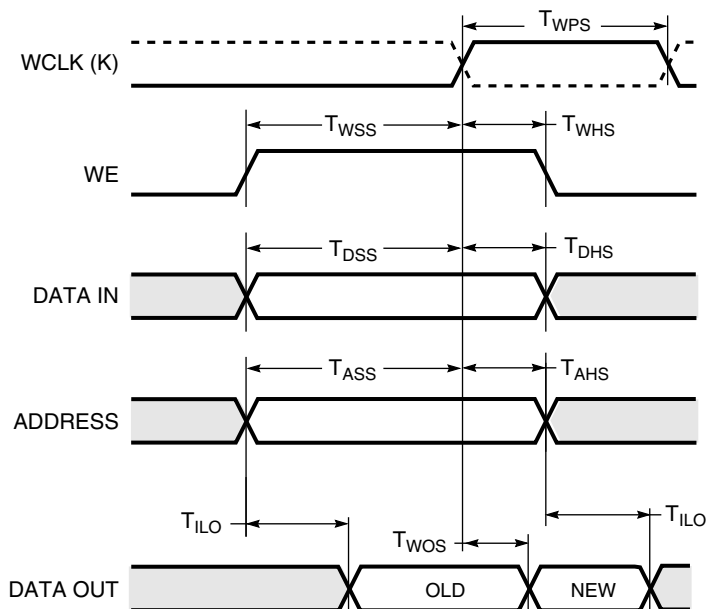

DS060\_34\_011300

## Spartan Family Pin-to-Pin Output Parameter Guidelines

All devices are 100% functionally tested. Pin-to-pin timing parameters are derived from measuring external and internal test patterns and are guaranteed over worst-case operating conditions (supply voltage and junction temperature). Listed below are representative values for typical pin locations and normal clock loading. For more specific, more pre-

cise, and worst-case guaranteed data, reflecting the actual routing structure, use the values provided by the static timing analyzer (TRCE in the Xilinx Development System) and back-annotated to the simulation netlist. These path delays, provided as a guideline, have been extracted from the static timing analyzer report.

### Spartan Family Output Flip-Flop, Clock-to-Out

Symbol	Description	Device	Speed Grade		Units
			-4	-3	
			Max	Max	
<b>Global Primary Clock to TTL Output using OFF</b>					
$T_{ICKOF}$	Fast	XCS05	5.3	8.7	ns
		XCS10	5.7	9.1	ns
		XCS20	6.1	9.3	ns
		XCS30	6.5	9.4	ns
		XCS40	6.8	10.2	ns
$T_{ICKO}$	Slew-rate limited	XCS05	9.0	11.5	ns
		XCS10	9.4	12.0	ns
		XCS20	9.8	12.2	ns
		XCS30	10.2	12.8	ns
		XCS40	10.5	12.8	ns
<b>Global Secondary Clock to TTL Output using OFF</b>					
$T_{ICKSOF}$	Fast	XCS05	5.8	9.2	ns
		XCS10	6.2	9.6	ns
		XCS20	6.6	9.8	ns
		XCS30	7.0	9.9	ns
		XCS40	7.3	10.7	ns
$T_{ICKSO}$	Slew-rate limited	XCS05	9.5	12.0	ns
		XCS10	9.9	12.5	ns
		XCS20	10.3	12.7	ns
		XCS30	10.7	13.2	ns
		XCS40	11.0	14.3	ns
<b>Delay Adder for CMOS Outputs Option</b>					
$T_{CMOSOF}$	Fast	All devices	0.8	1.0	ns
$T_{CMOSO}$	Slew-rate limited	All devices	1.5	2.0	ns

**Notes:**

1. Listed above are representative values where one global clock input drives one vertical clock line in each accessible column, and where all accessible IOB and CLB flip-flops are clocked by the global clock net.
2. Output timing is measured at ~50%  $V_{CC}$  threshold with 50 pF external capacitive load. For different loads, see [Figure 34](#).
3. OFF = Output Flip-Flop

### Capacitive Load Factor

Figure 34 shows the relationship between I/O output delay and load capacitance. It allows a user to adjust the specified output delay if the load capacitance is different than 50 pF. For example, if the actual load capacitance is 120 pF, add 2.5 ns to the specified delay. If the load capacitance is 20 pF, subtract 0.8 ns from the specified output delay. Figure 34 is usable over the specified operating conditions of voltage and temperature and is independent of the output slew rate control.



DS060\_35\_080400

Figure 34: Delay Factor at Various Capacitive Loads

## Spartan Family Pin-to-Pin Input Parameter Guidelines

All devices are 100% functionally tested. Pin-to-pin timing parameters are derived from measuring external and internal test patterns and are guaranteed over worst-case oper-

ating conditions (supply voltage and junction temperature). Listed below are representative values for typical pin locations and normal clock loading.

### Spartan Family Primary and Secondary Setup and Hold

Symbol	Description	Device	Speed Grade		Units
			-4	-3	
			Min	Min	
<b>Input Setup/Hold Times Using Primary Clock and IFF</b>					
$T_{PSUF}/T_{PHF}$	No Delay	XCS05	1.2 / 1.7	1.8 / 2.5	ns
		XCS10	1.0 / 2.3	1.5 / 3.4	ns
		XCS20	0.8 / 2.7	1.2 / 4.0	ns
		XCS30	0.6 / 3.0	0.9 / 4.5	ns
		XCS40	0.4 / 3.5	0.6 / 5.2	ns
$T_{PSU}/T_{PH}$	With Delay	XCS05	4.3 / 0.0	6.0 / 0.0	ns
		XCS10	4.3 / 0.0	6.0 / 0.0	ns
		XCS20	4.3 / 0.0	6.0 / 0.0	ns
		XCS30	4.3 / 0.0	6.0 / 0.0	ns
		XCS40	5.3 / 0.0	6.8 / 0.0	ns
<b>Input Setup/Hold Times Using Secondary Clock and IFF</b>					
$T_{SSUF}/T_{SHF}$	No Delay	XCS05	0.9 / 2.2	1.5 / 3.0	ns
		XCS10	0.7 / 2.8	1.2 / 3.9	ns
		XCS20	0.5 / 3.2	0.9 / 4.5	ns
		XCS30	0.3 / 3.5	0.6 / 5.0	ns
		XCS40	0.1 / 4.0	0.3 / 5.7	ns
$T_{SSU}/T_{SH}$	With Delay	XCS05	4.0 / 0.0	5.7 / 0.0	ns
		XCS10	4.0 / 0.0	5.7 / 0.0	ns
		XCS20	4.0 / 0.5	5.7 / 0.5	ns
		XCS30	4.0 / 0.5	5.7 / 0.5	ns
		XCS40	5.0 / 0.0	6.5 / 0.0	ns

**Notes:**

1. Setup time is measured with the fastest route and the lightest load. Hold time is measured using the furthest distance and a reference load of one clock pin per IOB/CLB.
2. IFF = Input Flip-flop or Latch

## Spartan Family IOB Input Switching Characteristic Guidelines

All devices are 100% functionally tested. Internal timing parameters are derived from measuring internal test patterns. Listed below are representative values. For more specific, more precise, and worst-case guaranteed data, use the values reported by the static timing analyzer (TRCE

in the Xilinx Development System) and back-annotated to the simulation netlist. These path delays, provided as a guideline, have been extracted from the static timing analyzer report. All timing parameters assume worst-case operating conditions (supply voltage and junction temperature).

Symbol	Description	Device	Speed Grade				Units
			-4		-3		
			Min	Max	Min	Max	
<b>Setup Times - TTL Inputs<sup>(1)</sup></b>							
T <sub>ECIK</sub>	Clock Enable (EC) to Clock (IK), no delay	All devices	1.6	-	2.1	-	ns
T <sub>PICK</sub>	Pad to Clock (IK), no delay	All devices	1.5	-	2.0	-	ns
<b>Hold Times</b>							
T <sub>IKEC</sub>	Clock Enable (EC) to Clock (IK), no delay	All devices	0.0	-	0.9	-	ns
	All Other Hold Times	All devices	0.0	-	0.0	-	ns
<b>Propagation Delays - TTL Inputs<sup>(1)</sup></b>							
T <sub>PID</sub>	Pad to I1, I2	All devices	-	1.5	-	2.0	ns
T <sub>PLI</sub>	Pad to I1, I2 via transparent input latch, no delay	All devices	-	2.8	-	3.6	ns
T <sub>IKRI</sub>	Clock (IK) to I1, I2 (flip-flop)	All devices	-	2.7	-	2.8	ns
T <sub>IKLI</sub>	Clock (IK) to I1, I2 (latch enable, active Low)	All devices	-	3.2	-	3.9	ns
<b>Delay Adder for Input with Delay Option</b>							
T <sub>Delay</sub>	$T_{ECIKD} = T_{ECIK} + T_{Delay}$ $T_{PICKD} = T_{PICK} + T_{Delay}$ $T_{PDLI} = T_{PLI} + T_{Delay}$	XCS05	3.6	-	4.0	-	ns
		XCS10	3.7	-	4.1	-	ns
		XCS20	3.8	-	4.2	-	ns
		XCS30	4.5	-	5.0	-	ns
		XCS40	5.5	-	5.5	-	ns
<b>Global Set/Reset</b>							
T <sub>MRW</sub>	Minimum GSR pulse width	All devices	11.5	-	13.5	-	ns
T <sub>RRI</sub>	Delay from GSR input to any Q	XCS05	-	9.0	-	11.3	ns
		XCS10	-	9.5	-	11.9	ns
		XCS20	-	10.0	-	12.5	ns
		XCS30	-	10.5	-	13.1	ns
		XCS40	-	11.0	-	13.8	ns

**Notes:**

1. Delay adder for CMOS Inputs option: for -3 speed grade, add 0.4 ns; for -4 speed grade, add 0.2 ns.
2. Input pad setup and hold times are specified with respect to the internal clock (IK). For setup and hold times with respect to the clock input, see the pin-to-pin parameters in the Pin-to-Pin Input Parameters table.
3. Voltage levels of unused pads, bonded or unbonded, must be valid logic levels. Each can be configured with the internal pull-up (default) or pull-down resistor, or configured as a driven output, or can be driven from an external source.

## Spartan Family IOB Output Switching Characteristic Guidelines

All devices are 100% functionally tested. Internal timing parameters are derived from measuring internal test patterns. Listed below are representative values. For more specific, more precise, and worst-case guaranteed data, use the values reported by the static timing analyzer (TRCE in the Xilinx Development System) and back-annotated to

the simulation netlist. These path delays, provided as a guideline, have been extracted from the static timing analyzer report. All timing parameters assume worst-case operating conditions (supply voltage and junction temperature). Values are expressed in nanoseconds unless otherwise noted.

Symbol	Description	Device	Speed Grade				Units
			-4		-3		
			Min	Max	Min	Max	
<b>Clocks</b>							
$T_{CH}$	Clock High	All devices	3.0	-	4.0	-	ns
$T_{CL}$	Clock Low	All devices	3.0	-	4.0	-	ns
<b>Propagation Delays - TTL Outputs<sup>(1,2)</sup></b>							
$T_{OKPOF}$	Clock (OK) to Pad, fast	All devices	-	3.3	-	4.5	ns
$T_{OKPOS}$	Clock (OK) to Pad, slew-rate limited	All devices	-	6.9	-	7.0	ns
$T_{OPF}$	Output (O) to Pad, fast	All devices	-	3.6	-	4.8	ns
$T_{OPS}$	Output (O) to Pad, slew-rate limited	All devices	-	7.2	-	7.3	ns
$T_{TSHZ}$	3-state to Pad High-Z (slew-rate independent)	All devices	-	3.0	-	3.8	ns
$T_{TSONF}$	3-state to Pad active and valid, fast	All devices	-	6.0	-	7.3	ns
$T_{TSONS}$	3-state to Pad active and valid, slew-rate limited	All devices	-	9.6	-	9.8	ns
<b>Setup and Hold Times</b>							
$T_{OOK}$	Output (O) to clock (OK) setup time	All devices	2.5	-	3.8	-	ns
$T_{OKO}$	Output (O) to clock (OK) hold time	All devices	0.0	-	0.0	-	ns
$T_{ECOK}$	Clock Enable (EC) to clock (OK) setup time	All devices	2.0	-	2.7	-	ns
$T_{OKEC}$	Clock Enable (EC) to clock (OK) hold time	All devices	0.0	-	0.5	-	ns
<b>Global Set/Reset</b>							
$T_{MRW}$	Minimum GSR pulse width	All devices	11.5		13.5		ns
$T_{RPO}$	Delay from GSR input to any Pad	XCS05	-	12.0	-	15.0	ns
		XCS10	-	12.5	-	15.7	ns
		XCS20	-	13.0	-	16.2	ns
		XCS30	-	13.5	-	16.9	ns
		XCS40	-	14.0	-	17.5	ns

**Notes:**

1. Delay adder for CMOS Outputs option (with fast slew rate option): for -3 speed grade, add 1.0 ns; for -4 speed grade, add 0.8 ns.
2. Delay adder for CMOS Outputs option (with slow slew rate option): for -3 speed grade, add 2.0 ns; for -4 speed grade, add 1.5 ns.
3. Output timing is measured at ~50%  $V_{CC}$  threshold, with 50 pF external capacitive loads including test fixture. Slew-rate limited output rise/fall times are approximately two times longer than fast output rise/fall times.
4. Voltage levels of unused pads, bonded or unbonded, must be valid logic levels. Each can be configured with the internal pull-up (default) or pull-down resistor, or configured as a driven output, or can be driven from an external source.

## Spartan-XL Family Detailed Specifications

### Definition of Terms

In the following tables, some specifications may be designated as Advance or Preliminary. These terms are defined as follows:

**Advance:** Initial estimates based on simulation and/or extrapolation from other speed grades, devices, or device families. Values are subject to change. Use as estimates, not for production.

**Preliminary:** Based on preliminary characterization. Further changes are not expected.

**Unmarked:** Specifications not identified as either Advance or Preliminary are to be considered Final.

Notwithstanding the definition of the above terms, all specifications are subject to change without notice.

Except for pin-to-pin input and output parameters, the AC parameter delay specifications included in this document are derived from measuring internal test patterns. All specifications are representative of worst-case supply voltage and junction temperature conditions. The parameters included are common to popular designs and typical applications.

### Spartan-XL Family Absolute Maximum Ratings<sup>(1)</sup>

Symbol	Description		Value	Units
$V_{CC}$	Supply voltage relative to GND		-0.5 to 4.0	V
$V_{IN}$	Input voltage relative to GND	5V Tolerant I/O Checked <sup>(2, 3)</sup>	-0.5 to 5.5	V
		Not 5V Tolerant I/Os <sup>(4, 5)</sup>	-0.5 to $V_{CC} + 0.5$	V
$V_{TS}$	Voltage applied to 3-state output	5V Tolerant I/O Checked <sup>(2, 3)</sup>	-0.5 to 5.5	V
		Not 5V Tolerant I/Os <sup>(4, 5)</sup>	-0.5 to $V_{CC} + 0.5$	V
$T_{STG}$	Storage temperature (ambient)		-65 to +150	°C
$T_J$	Junction temperature	Plastic packages	+125	°C

#### Notes:

- Stresses beyond those listed under Absolute Maximum Ratings may cause permanent damage to the device. These are stress ratings only, and functional operation of the device at these or any other conditions beyond those listed under Operating Conditions is not implied. Exposure to Absolute Maximum Ratings conditions for extended periods of time may affect device reliability.
- With 5V Tolerant I/Os selected, the Maximum DC overshoot must be limited to either +5.5V or 10 mA and undershoot (below GND) must be limited to either 0.5V or 10 mA, whichever is easier to achieve.
- With 5V Tolerant I/Os selected, the Maximum AC (during transitions) conditions are as follows; the device pins may undershoot to -2.0V or overshoot to +7.0V, provided this overshoot or undershoot lasts no more than 11 ns with a forcing current no greater than 100 mA.
- Without 5V Tolerant I/Os selected, the Maximum DC overshoot or undershoot must be limited to either 0.5V or 10 mA, whichever is easier to achieve.
- Without 5V Tolerant I/Os selected, the Maximum AC conditions are as follows; the device pins may undershoot to -2.0V or overshoot to  $V_{CC} + 2.0V$ , provided this overshoot or undershoot lasts no more than 11 ns with a forcing current no greater than 100 mA.
- For soldering guidelines, see the Package Information on the Xilinx website.

### Spartan-XL Family Recommended Operating Conditions

Symbol	Description		Min	Max	Units
$V_{CC}$	Supply voltage relative to GND, $T_J = 0^\circ\text{C}$ to $+85^\circ\text{C}$	Commercial	3.0	3.6	V
	Supply voltage relative to GND, $T_J = -40^\circ\text{C}$ to $+100^\circ\text{C}$ <sup>(1)</sup>	Industrial	3.0	3.6	V
$V_{IH}$	High-level input voltage <sup>(2)</sup>		50% of $V_{CC}$	5.5	V
$V_{IL}$	Low-level input voltage <sup>(2)</sup>		0	30% of $V_{CC}$	V
$T_{IN}$	Input signal transition time		-	250	ns

#### Notes:

- At junction temperatures above those listed as Operating Conditions, all delay parameters increase by 0.35% per °C.
- Input and output measurement threshold is ~50% of  $V_{CC}$ .

**Spartan-XL Family DC Characteristics Over Operating Conditions**

Symbol	Description	Min	Typ.	Max	Units	
V <sub>OH</sub>	High-level output voltage @ I <sub>OH</sub> = -4.0 mA, V <sub>CC</sub> min (LVTTL)	2.4	-	-	V	
	High-level output voltage @ I <sub>OH</sub> = -500 μA, (LVCMOS)	90% V <sub>CC</sub>	-	-	V	
V <sub>OL</sub>	Low-level output voltage @ I <sub>OL</sub> = 12.0 mA, V <sub>CC</sub> min (LVTTL) <sup>(1)</sup>	-	-	0.4	V	
	Low-level output voltage @ I <sub>OL</sub> = 24.0 mA, V <sub>CC</sub> min (LVTTL) <sup>(2)</sup>	-	-	0.4	V	
	Low-level output voltage @ I <sub>OL</sub> = 1500 μA, (LVCMOS)	-	-	10% V <sub>CC</sub>	V	
V <sub>DR</sub>	Data retention supply voltage (below which configuration data may be lost)	2.5	-	-	V	
I <sub>CCO</sub>	Quiescent FPGA supply current <sup>(3,4)</sup>	Commercial	-	0.1	2.5	mA
		Industrial	-	0.1	5	mA
I <sub>CCPD</sub>	Power Down FPGA supply current <sup>(3,5)</sup>	Commercial	-	0.1	2.5	mA
		Industrial	-	0.1	5	mA
I <sub>L</sub>	Input or output leakage current	-10	-	10	μA	
C <sub>IN</sub>	Input capacitance (sample tested)	-	-	10	pF	
I <sub>RPU</sub>	Pad pull-up (when selected) @ V <sub>IN</sub> = 0V (sample tested)	0.02	-	0.25	mA	
I <sub>RPD</sub>	Pad pull-down (when selected) @ V <sub>IN</sub> = 3.3V (sample tested)	0.02	-	-	mA	

**Notes:**

1. With up to 64 pins simultaneously sinking 12 mA (default mode).
2. With up to 64 pins simultaneously sinking 24 mA (with 24 mA option selected).
3. With 5V tolerance not selected, no internal oscillators, and the FPGA configured with the Tie option.
4. With no output current loads, no active input resistors, and all package pins at V<sub>CC</sub> or GND.
5. With  $\overline{\text{PWRDWN}}$  active.

**Supply Current Requirements During Power-On**

Spartan-XL FPGAs require that a minimum supply current I<sub>CCPO</sub> be provided to the V<sub>CC</sub> lines for a successful power on. If more current is available, the FPGA can consume more than I<sub>CCPO</sub> min., though this cannot adversely affect reliability.

A maximum limit for I<sub>CCPO</sub> is not specified. Be careful when using foldback/crowbar supplies and fuses. It is possible to control the magnitude of I<sub>CCPO</sub> by limiting the supply current available to the FPGA. A current limit below the trip level will avoid inadvertently activating over-current protection circuits.

Symbol	Description	Min	Max	Units
I <sub>CCPO</sub>	Total V <sub>CC</sub> supply current required during power-on	100	-	mA
T <sub>CCPO</sub>	V <sub>CC</sub> ramp time <sup>(2,3)</sup>	-	50	ms

**Notes:**

1. The I<sub>CCPO</sub> requirement applies for a brief time (commonly only a few milliseconds) when V<sub>CC</sub> ramps from 0 to 3.3V.
2. The ramp time is measured from GND to V<sub>CC</sub> max on a fully loaded board.
3. V<sub>CC</sub> must not dip in the negative direction during power on.

## Spartan-XL Family Global Buffer Switching Characteristic Guidelines

All devices are 100% functionally tested. Internal timing parameters are derived from measuring internal test patterns. Listed below are representative values where one global clock input drives one vertical clock line in each accessible column, and where all accessible IOB and CLB flip-flops are clocked by the global clock net.

When fewer vertical clock lines are connected, the clock distribution is faster; when multiple clock lines per column are driven from the same global clock, the delay is longer. For

more specific, more precise, and worst-case guaranteed data, reflecting the actual routing structure, use the values provided by the static timing analyzer (TRCE in the Xilinx Development System) and back-annotated to the simulation netlist. These path delays, provided as a guideline, have been extracted from the static timing analyzer report. All timing parameters assume worst-case operating conditions (supply voltage and junction temperature).

Symbol	Description	Device	Speed Grade		Units
			-5	-4	
			Max	Max	
$T_{GLS}$	From pad through buffer, to any clock K	XCS05XL	1.4	1.5	ns
		XCS10XL	1.7	1.8	ns
		XCS20XL	2.0	2.1	ns
		XCS30XL	2.3	2.5	ns
		XCS40XL	2.6	2.8	ns

## Spartan-XL Family CLB Switching Characteristic Guidelines

All devices are 100% functionally tested. Internal timing parameters are derived from measuring internal test patterns. Listed below are representative values. For more specific, more precise, and worst-case guaranteed data, use the values reported by the static timing analyzer (TRCE

in the Xilinx Development System) and back-annotated to the simulation netlist. All timing parameters assume worst-case operating conditions (supply voltage and junction temperature). Values apply to all Spartan-XL devices and expressed in nanoseconds unless otherwise noted.

Symbol	Description	Speed Grade				Units
		-5		-4		
		Min	Max	Min	Max	
<b>Clocks</b>						
T <sub>CH</sub>	Clock High time	2.0	-	2.3	-	ns
T <sub>CL</sub>	Clock Low time	2.0	-	2.3	-	ns
<b>Combinatorial Delays</b>						
T <sub>ILO</sub>	F/G inputs to X/Y outputs	-	1.0	-	1.1	ns
T <sub>IHO</sub>	F/G inputs via H to X/Y outputs	-	1.7	-	2.0	ns
T <sub>ITO</sub>	F/G inputs via transparent latch to Q outputs	-	1.5	-	1.8	ns
T <sub>HH1O</sub>	C inputs via H1 via H to X/Y outputs	-	1.5	-	1.8	ns
<b>Sequential Delays</b>						
T <sub>CKO</sub>	Clock K to Flip-Flop or latch outputs Q	-	1.2	-	1.4	ns
<b>Setup Time before Clock K</b>						
T <sub>ICK</sub>	F/G inputs	0.6	-	0.7	-	ns
T <sub>IHCK</sub>	F/G inputs via H	1.3	-	1.6	-	ns
<b>Hold Time after Clock K</b>						
	All Hold times, all devices	0.0	-	0.0	-	ns
<b>Set/Reset Direct</b>						
T <sub>RPW</sub>	Width (High)	2.5	-	2.8	-	ns
T <sub>RIO</sub>	Delay from C inputs via S/R, going High to Q	-	2.3	-	2.7	ns
<b>Global Set/Reset</b>						
T <sub>MRW</sub>	Minimum GSR Pulse Width	10.5	-	11.5	-	ns
T <sub>MRQ</sub>	Delay from GSR input to any Q	See <a href="#">page 60</a> for T <sub>RR1</sub> values per device.				
F <sub>TOG</sub>	Toggle Frequency (MHz) (for export control purposes)	-	250	-	217	MHz

## Spartan-XL Family CLB RAM Synchronous (Edge-Triggered) Write Operation Guidelines

All devices are 100% functionally tested. Internal timing parameters are derived from measuring internal test patterns. Listed below are representative values. For more specific, more precise, and worst-case guaranteed data, use the values reported by the static timing analyzer (TRCE

in the Xilinx Development System) and back-annotated to the simulation netlist. All timing parameters assume worst-case operating conditions (supply voltage and junction temperature). Values apply to all Spartan-XL devices and are expressed in nanoseconds unless otherwise noted.

Symbol	Single Port RAM	Size <sup>(1)</sup>	Speed Grade				Units
			-5		-4		
			Min	Max	Min	Max	
<b>Write Operation</b>							
$T_{WCS}$	Address write cycle time (clock K period)	16x2	7.7	-	8.4	-	ns
$T_{WCTS}$		32x1	7.7	-	8.4	-	ns
$T_{WPS}$	Clock K pulse width (active edge)	16x2	3.1	-	3.6	-	ns
$T_{WPTS}$		32x1	3.1	-	3.6	-	ns
$T_{ASS}$	Address setup time before clock K	16x2	1.3	-	1.5	-	ns
$T_{ASTS}$		32x1	1.5	-	1.7	-	ns
$T_{DSS}$	DIN setup time before clock K	16x2	1.5	-	1.7	-	ns
$T_{DSTS}$		32x1	1.8	-	2.1	-	ns
$T_{WSS}$	WE setup time before clock K	16x2	1.4	-	1.6	-	ns
$T_{WSTS}$		32x1	1.3	-	1.5	-	ns
	All hold times after clock K	16x2	0.0	-	0.0	-	ns
$T_{WOS}$	Data valid after clock K	32x1	-	4.5	-	5.3	ns
$T_{WOTS}$		16x2	-	5.4	-	6.3	ns
<b>Read Operation</b>							
$T_{RC}$	Address read cycle time	16x2	2.6	-	3.1	-	ns
$T_{RCT}$		32x1	3.8	-	5.5	-	ns
$T_{ILO}$	Data Valid after address change (no Write Enable)	16x2	-	1.0	-	1.1	ns
$T_{IHO}$		32x1	-	1.7	-	2.0	ns
$T_{ICK}$	Address setup time before clock K	16x2	0.6	-	0.7	-	ns
$T_{IHCK}$		32x1	1.3	-	1.6	-	ns

**Notes:**

1. Timing for 16 x 1 RAM option is identical to 16 x 2 RAM timing.

### Spartan-XL Family CLB RAM Synchronous (Edge-Triggered) Write Operation Guidelines (cont.)

All devices are 100% functionally tested. Internal timing parameters are derived from measuring internal test patterns. Listed below are representative values. For more specific, more precise, and worst-case guaranteed data, use the values reported by the static timing analyzer (TRCE

in the Xilinx Development System) and back-annotated to the simulation netlist. All timing parameters assume worst-case operating conditions (supply voltage and junction temperature). Values apply to all Spartan-XL devices and are expressed in nanoseconds unless otherwise noted.

Symbol	Dual Port RAM	Size	-5		-4		Units
			Min	Max	Min	Max	
<b>Write Operation<sup>(1)</sup></b>							
$T_{WCDS}$	Address write cycle time (clock K period)	16x1	7.7	-	8.4	-	ns
$T_{WPDS}$	Clock K pulse width (active edge)	16x1	3.1	-	3.6	-	ns
$T_{ASDS}$	Address setup time before clock K	16x1	1.3	-	1.5	-	ns
$T_{DSDS}$	DIN setup time before clock K	16x1	1.7	-	2.0	-	ns
$T_{WSDS}$	WE setup time before clock K	16x1	1.4	-	1.6	-	ns
	All hold times after clock K	16x1	0	-	0	-	ns
$T_{WODS}$	Data valid after clock K	16x1	-	5.2	-	6.1	ns

**Notes:**

1. Read Operation timing for 16 x 1 dual-port RAM option is identical to 16 x 2 single-port RAM timing

### Spartan-XL Family CLB RAM Synchronous (Edge-Triggered) Write Timing

**Single Port**

**Dual Port**

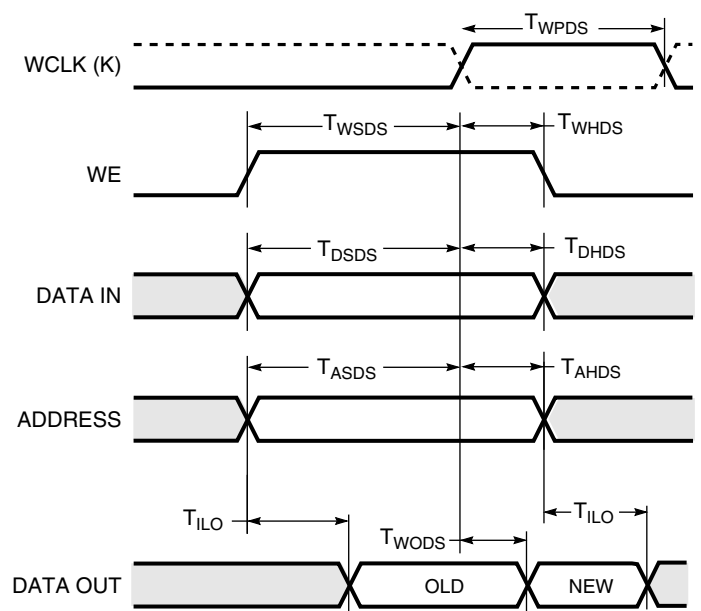

DS060\_34\_011300

## Spartan-XL Family Pin-to-Pin Output Parameter Guidelines

All devices are 100% functionally tested. Pin-to-pin timing parameters are derived from measuring external and internal test patterns and are guaranteed over worst-case oper-

ating conditions (supply voltage and junction temperature). Listed below are representative values for typical pin locations and normal clock loading.

### Spartan-XL Family Output Flip-Flop, Clock-to-Out

Symbol	Description	Device	Speed Grade		Units
			-5	-4	
			Max	Max	
<b>Global Clock to Output using OFF</b>					
T <sub>ICKOF</sub>	Fast	XCS05XL	4.6	5.2	ns
		XCS10XL	4.9	5.5	ns
		XCS20XL	5.2	5.8	ns
		XCS30XL	5.5	6.2	ns
		XCS40XL	5.8	6.5	ns
<b>Slew Rate Adjustment</b>					
T <sub>SLOW</sub>	For Output SLOW option add	All Devices	1.5	1.7	ns

#### Notes:

- Output delays are representative values where one global clock input drives one vertical clock line in each accessible column, and where all accessible IOB and CLB flip-flops are clocked by the global clock net.
- Output timing is measured at ~50% V<sub>CC</sub> threshold with 50 pF external capacitive load.
- OFF = Output Flip Flop

### Spartan-XL Family Pin-to-Pin Input Parameter Guidelines

All devices are 100% functionally tested. Pin-to-pin timing parameters are derived from measuring external and internal test patterns and are guaranteed over worst-case oper-

ating conditions (supply voltage and junction temperature). Listed below are representative values for typical pin locations and normal clock loading.

#### Spartan-XL Family Setup and Hold

Symbol	Description	Device	Speed Grade		Units
			-5	-4	
			Max	Max	
<b>Input Setup/Hold Times Using Global Clock and IFF</b>					
$T_{SUF}/T_{HF}$	No Delay	XCS05XL	1.1/2.0	1.6/2.6	ns
		XCS10XL	1.0/2.2	1.5/2.8	ns
		XCS20XL	0.9/2.4	1.4/3.0	ns
		XCS30XL	0.8/2.6	1.3/3.2	ns
		XCS40XL	0.7/2.8	1.2/3.4	ns
$T_{SU}/T_H$	Full Delay	XCS05XL	3.9/0.0	5.1/0.0	ns
		XCS10XL	4.1/0.0	5.3/0.0	ns
		XCS20XL	4.3/0.0	5.5/0.0	ns
		XCS30XL	4.5/0.0	5.7/0.0	ns
		XCS40XL	4.7/0.0	5.9/0.0	ns

**Notes:**

1. IFF = Input Flip-Flop or Latch
2. Setup time is measured with the fastest route and the lightest load. Hold time is measured using the furthest distance and a reference load of one clock pin per IOB/CLB.

#### Capacitive Load Factor

Figure 35 shows the relationship between I/O output delay and load capacitance. It allows a user to adjust the specified output delay if the load capacitance is different than 50 pF. For example, if the actual load capacitance is 120 pF, add 2.5 ns to the specified delay. If the load capacitance is 20 pF, subtract 0.8 ns from the specified output delay. Figure 35 is usable over the specified operating conditions of voltage and temperature and is independent of the output slew rate control.

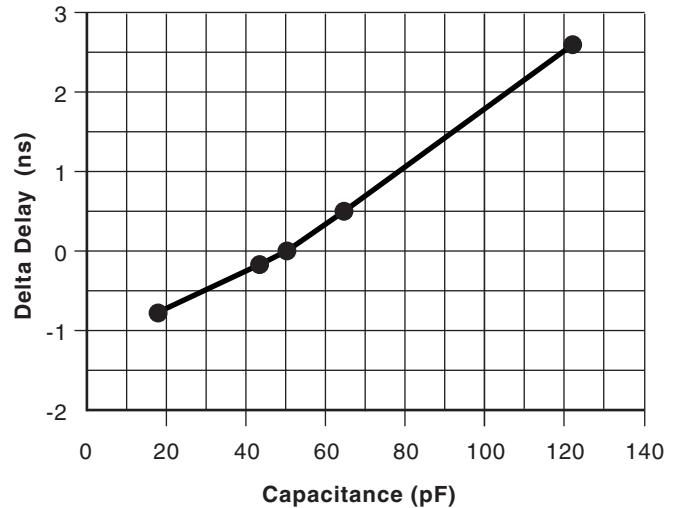

DS060\_35\_080400

Figure 35: Delay Factor at Various Capacitive Loads

## Spartan-XL Family IOB Input Switching Characteristic Guidelines

All devices are 100% functionally tested. Internal timing parameters are derived from measuring internal test patterns. Listed below are representative values. For more specific, more precise, and worst-case guaranteed data, use the values reported by the static timing analyzer (TRCE

in the Xilinx Development System) and back-annotated to the simulation netlist. These path delays, provided as a guideline, have been extracted from the static timing analyzer report. All timing parameters assume worst-case operating conditions (supply voltage and junction temperature).

Symbol	Description	Device	Speed Grade				Units
			-5		-4		
			Min	Max	Min	Max	
<b>Setup Times</b>							
$T_{EICK}$	Clock Enable (EC) to Clock (IK)	All devices	0.0	-	0.0	-	ns
$T_{PICK}$	Pad to Clock (IK), no delay	All devices	1.0	-	1.2	-	ns
$T_{POCK}$	Pad to Fast Capture Latch Enable (OK), no delay	All devices	0.7	-	0.8	-	ns
<b>Hold Times</b>							
	All Hold Times	All devices	0.0	-	0.0	-	ns
<b>Propagation Delays</b>							
$T_{PID}$	Pad to I1, I2	All devices	-	0.9	-	1.1	ns
$T_{PLI}$	Pad to I1, I2 via transparent input latch, no delay	All devices	-	2.1	-	2.5	ns
$T_{IKRI}$	Clock (IK) to I1, I2 (flip-flop)	All devices	-	1.0	-	1.1	ns
$T_{IKLI}$	Clock (IK) to I1, I2 (latch enable, active Low)	All devices	-	1.1	-	1.2	ns
<b>Delay Adder for Input with Full Delay Option</b>							
$T_{Delay}$	$T_{PICKD} = T_{PICK} + T_{Delay}$ $T_{PDLI} = T_{PLI} + T_{Delay}$	XCS05XL	4.0	-	4.7	-	ns
		XCS10XL	4.8	-	5.6	-	ns
		XCS20XL	5.0	-	5.9	-	ns
		XCS30XL	5.5	-	6.5	-	ns
		XCS40XL	6.5	-	7.6	-	ns
<b>Global Set/Reset</b>							
$T_{MRW}$	Minimum GSR pulse width	All devices	10.5	-	11.5	-	ns
$T_{RRI}$	Delay from GSR input to any Q	XCS05XL	-	9.0	-	10.5	ns
		XCS10XL	-	9.5	-	11.0	ns
		XCS20XL	-	10.0	-	11.5	ns
		XCS30XL	-	11.0	-	12.5	ns
		XCS40XL	-	12.0	-	13.5	ns

**Notes:**

- Input pad setup and hold times are specified with respect to the internal clock (IK). For setup and hold times with respect to the clock input, see the pin-to-pin parameters in the Pin-to-Pin Input Parameters table.
- Voltage levels of unused pads, bonded or unbonded, must be valid logic levels. Each can be configured with the internal pull-up (default) or pull-down resistor, or configured as a driven output, or can be driven from an external source.

## Spartan-XL Family IOB Output Switching Characteristic Guidelines

All devices are 100% functionally tested. Internal timing parameters are derived from measuring internal test patterns. Listed below are representative values. For more specific, more precise, and worst-case guaranteed data, use the values reported by the static timing analyzer (TRCE in the Xilinx Development System) and back-annotated to

the simulation netlist. These path delays, provided as a guideline, have been extracted from the static timing analyzer report. All timing parameters assume worst-case operating conditions (supply voltage and junction temperature). Values are expressed in nanoseconds unless otherwise noted.

Symbol	Description	Device	Speed Grade				Units
			-5		-4		
			Min	Max	Min	Max	
<b>Propagation Delays</b>							
T <sub>OKPOF</sub>	Clock (OK) to Pad, fast	All devices	-	3.2	-	3.7	ns
T <sub>OPF</sub>	Output (O) to Pad, fast	All devices	-	2.5	-	2.9	ns
T <sub>TSHZ</sub>	3-state to Pad High-Z (slew-rate independent)	All devices	-	2.8	-	3.3	ns
T <sub>TSONF</sub>	3-state to Pad active and valid, fast	All devices	-	2.6	-	3.0	ns
T <sub>OFFPF</sub>	Output (O) to Pad via Output MUX, fast	All devices	-	3.7	-	4.4	ns
T <sub>OKFPF</sub>	Select (OK) to Pad via Output MUX, fast	All devices	-	3.3	-	3.9	ns
T <sub>SLOW</sub>	For Output SLOW option add	All devices	-	1.5	-	1.7	ns
<b>Setup and Hold Times</b>							
T <sub>OOK</sub>	Output (O) to clock (OK) setup time	All devices	0.5	-	0.5	-	ns
T <sub>OKO</sub>	Output (O) to clock (OK) hold time	All devices	0.0	-	0.0	-	ns
T <sub>ECOK</sub>	Clock Enable (EC) to clock (OK) setup time	All devices	0.0	-	0.0	-	ns
T <sub>OKEC</sub>	Clock Enable (EC) to clock (OK) hold time	All devices	0.1	-	0.2	-	ns
<b>Global Set/Reset</b>							
T <sub>MRW</sub>	Minimum GSR pulse width	All devices	10.5	-	11.5	-	ns
T <sub>RP0</sub>	Delay from GSR input to any Pad	XCS05XL	-	11.9	-	14.0	ns
		XCS10XL	-	12.4	-	14.5	ns
		XCS20XL	-	12.9	-	15.0	ns
		XCS30XL	-	13.9	-	16.0	ns
		XCS40XL	-	14.9	-	17.0	ns

### Notes:

- Output timing is measured at ~50% V<sub>CC</sub> threshold, with 50 pF external capacitive loads including test fixture. Slew-rate limited output rise/fall times are approximately two times longer than fast output rise/fall times.
- Voltage levels of unused pads, bonded or unbonded, must be valid logic levels. Each can be configured with the internal pull-up (default) or pull-down resistor, or configured as a driven output, or can be driven from an external source.

## Pin Descriptions

There are three types of pins in the Spartan/XL devices:

- Permanently dedicated pins
- User I/O pins that can have special functions
- Unrestricted user-programmable I/O pins.

Before and during configuration, all outputs not used for the configuration process are 3-stated with the I/O pull-up resistor network activated. After configuration, if an IOB is unused it is configured as an input with the I/O pull-up resistor network remaining activated.

Any user I/O can be configured to drive the Global Set/Reset net GSR or the global three-state net GTS. See **Global Signals: GSR and GTS**, page 20 for more information.

Device pins for Spartan/XL devices are described in **Table 18**.

Some Spartan-XL devices are available in Pb-free package options. The Pb-free package options have the same pin-outs as the standard package options.

Table 18: Pin Descriptions

Pin Name	I/O During Config.	I/O After Config.	Pin Description
<b>Permanently Dedicated Pins</b>			
V <sub>CC</sub>	X	X	Eight or more (depending on package) connections to the nominal +5V supply voltage (+3.3V for Spartan-XL devices). All must be connected, and each must be decoupled with a 0.01 – 0.1 μF capacitor to Ground.
GND	X	X	Eight or more (depending on package type) connections to Ground. All must be connected.
CCLK	I or O	I	During configuration, Configuration Clock (CCLK) is an output in Master mode and is an input in Slave mode. After configuration, CCLK has a weak pull-up resistor and can be selected as the Readback Clock. There is no CCLK High or Low time restriction on Spartan/XL devices, except during Readback. See <b>Violating the Maximum High and Low Time Specification for the Readback Clock</b> , page 39 for an explanation of this exception.
DONE	I/O	O	DONE is a bidirectional signal with an optional internal pull-up resistor. As an open-drain output, it indicates the completion of the configuration process. As an input, a Low level on DONE can be configured to delay the global logic initialization and the enabling of outputs.  The optional pull-up resistor is selected as an option in the program that creates the configuration bitstream. The resistor is included by default.
$\overline{\text{PROGRAM}}$	I	I	$\overline{\text{PROGRAM}}$ is an active Low input that forces the FPGA to clear its configuration memory. It is used to initiate a configuration cycle. When $\overline{\text{PROGRAM}}$ goes High, the FPGA finishes the current clear cycle and executes another complete clear cycle, before it goes into a WAIT state and releases $\overline{\text{INIT}}$ .  The $\overline{\text{PROGRAM}}$ pin has a permanent weak pull-up, so it need not be externally pulled up to VCC.
MODE (Spartan) M0, M1 (Spartan-XL)	I	X	The Mode input(s) are sampled after $\overline{\text{INIT}}$ goes High to determine the configuration mode to be used.  During configuration, these pins have a weak pull-up resistor. For the most popular configuration mode, Slave Serial, the mode pins can be left unconnected. For Master Serial mode, connect the Mode/M0 pin directly to system ground.

Table 18: Pin Descriptions (Continued)

Pin Name	I/O During Config.	I/O After Config.	Pin Description
$\overline{\text{PWRDWN}}$	I	I	$\overline{\text{PWRDWN}}$ is an active Low input that forces the FPGA into the Power Down state and reduces power consumption. When $\overline{\text{PWRDWN}}$ is Low, the FPGA disables all I/O and initializes all flip-flops. All inputs are interpreted as Low independent of their actual level. VCC must be maintained, and the configuration data is maintained. $\overline{\text{PWRDWN}}$ halts configuration if asserted before or during configuration, and re-starts configuration when removed. When $\overline{\text{PWRDWN}}$ returns High, the FPGA becomes operational by first enabling the inputs and flip-flops and then enabling the outputs. $\overline{\text{PWRDWN}}$ has a default internal pull-up resistor.
<b>User I/O Pins That Can Have Special Functions</b>			
TDO	O	O	If boundary scan is used, this pin is the Test Data Output. If boundary scan is not used, this pin is a 3-state output without a register, after configuration is completed.  To use this pin, place the library component TDO instead of the usual pad symbol. An output buffer must still be used.
TDI, TCK, TMS	I	I/O or I (JTAG)	If boundary scan is used, these pins are Test Data In, Test Clock, and Test Mode Select inputs respectively. They come directly from the pads, bypassing the IOBs. These pins can also be used as inputs to the CLB logic after configuration is completed.  If the BSCAN symbol is not placed in the design, all boundary scan functions are inhibited once configuration is completed, and these pins become user-programmable I/O. In this case, they must be called out by special library elements. To use these pins, place the library components TDI, TCK, and TMS instead of the usual pad symbols. Input or output buffers must still be used.
HDC	O	I/O	High During Configuration (HDC) is driven High until the I/O go active. It is available as a control output indicating that configuration is not yet completed. After configuration, HDC is a user-programmable I/O pin.
$\overline{\text{LDC}}$	O	I/O	Low During Configuration ( $\overline{\text{LDC}}$ ) is driven Low until the I/O go active. It is available as a control output indicating that configuration is not yet completed. After configuration, $\overline{\text{LDC}}$ is a user-programmable I/O pin.
$\overline{\text{INIT}}$	I/O	I/O	Before and during configuration, $\overline{\text{INIT}}$ is a bidirectional signal. A 1 k $\Omega$ to 10 k $\Omega$ external pull-up resistor is recommended.  As an active Low open-drain output, $\overline{\text{INIT}}$ is held Low during the power stabilization and internal clearing of the configuration memory. As an active Low input, it can be used to hold the FPGA in the internal WAIT state before the start of configuration. Master mode devices stay in a WAIT state an additional 30 to 300 $\mu\text{s}$ after INIT has gone High.  During configuration, a Low on this output indicates that a configuration data error has occurred. After the I/O go active, $\overline{\text{INIT}}$ is a user-programmable I/O pin.
PGCK1 - PGCK4 (Spartan)	Weak Pull-up	I or I/O	Four Primary Global inputs each drive a dedicated internal global net with short delay and minimal skew. If not used to drive a global buffer, any of these pins is a user-programmable I/O.  The PGCK1-PGCK4 pins drive the four Primary Global Buffers. Any input pad symbol connected directly to the input of a BUF <sub>GP</sub> symbol is automatically placed on one of these pins.

Table 18: Pin Descriptions (Continued)

Pin Name	I/O During Config.	I/O After Config.	Pin Description
SGCK1 - SGCK4 (Spartan)	Weak Pull-up (except SGCK4 is DOUT)	I or I/O	Four Secondary Global inputs each drive a dedicated internal global net with short delay and minimal skew. These internal global nets can also be driven from internal logic. If not used to drive a global net, any of these pins is a user-programmable I/O pin.  The SGCK1-SGCK4 pins provide the shortest path to the four Secondary Global Buffers. Any input pad symbol connected directly to the input of a BUFGS symbol is automatically placed on one of these pins.
GCK1 - GCK8 (Spartan-XL)	Weak Pull-up (except GCK6 is DOUT)	I or I/O	Eight Global inputs each drive a dedicated internal global net with short delay and minimal skew. These internal global nets can also be driven from internal logic. If not used to drive a global net, any of these pins is a user-programmable I/O pin.  The GCK1-GCK8 pins provide the shortest path to the eight Global Low-Skew Buffers. Any input pad symbol connected directly to the input of a BUFGLS symbol is automatically placed on one of these pins.
CS1 (Spartan-XL)	I	I/O	During Express configuration, CS1 is used as a serial-enable signal for daisy-chaining.
D0-D7 (Spartan-XL)	I	I/O	During Express configuration, these eight input pins receive configuration data. After configuration, they are user-programmable I/O pins.
DIN	I	I/O	During Slave Serial or Master Serial configuration, DIN is the serial configuration data input receiving data on the rising edge of CCLK. After configuration, DIN is a user-programmable I/O pin.
DOUT	O	I/O	During Slave Serial or Master Serial configuration, DOUT is the serial configuration data output that can drive the DIN of daisy-chained slave FPGAs. DOUT data changes on the falling edge of CCLK, one-and-a-half CCLK periods after it was received at the DIN input.  In Spartan-XL family Express mode, DOUT is the status output that can drive the CS1 of daisy-chained FPGAs, to enable and disable downstream devices.  After configuration, DOUT is a user-programmable I/O pin.
<b>Unrestricted User-Programmable I/O Pins</b>			
I/O	Weak Pull-up	I/O	These pins can be configured to be input and/or output after configuration is completed. Before configuration is completed, these pins have an internal high-value pull-up resistor network that defines the logic level as High.

## Device-Specific Pinout Tables

Device-specific tables include all packages for each Spartan and Spartan-XL device. They follow the pad locations around the die, and include boundary scan register locations.

Some Spartan-XL devices are available in Pb-free package options. The Pb-free package options have the same pinouts as the standard package options.

### XCS05 and XCS05XL Device Pinouts

XCS05/XL Pad Name	PC84 <sup>(4)</sup>	VQ100	Bndry Scan
VCC	P2	P89	-
I/O	P3	P90	32
I/O	P4	P91	35
I/O	-	P92	38
I/O	-	P93	41
I/O	P5	P94	44
I/O	P6	P95	47
I/O	P7	P96	50
I/O	P8	P97	53
I/O	P9	P98	56
I/O, SGCK1 <sup>(1)</sup> , GCK8 <sup>(2)</sup>	P10	P99	59
VCC	P11	P100	-
GND	P12	P1	-
I/O, PGCK1 <sup>(1)</sup> , GCK1 <sup>(2)</sup>	P13	P2	62
I/O	P14	P3	65
I/O, TDI	P15	P4	68
I/O, TCK	P16	P5	71
I/O, TMS	P17	P6	74
I/O	P18	P7	77
I/O	-	P8	83
I/O	P19	P9	86
I/O	P20	P10	89
GND	P21	P11	-
VCC	P22	P12	-
I/O	P23	P13	92
I/O	P24	P14	95
I/O	-	P15	98
I/O	P25	P16	104
I/O	P26	P17	107
I/O	P27	P18	110
I/O	-	P19	113
I/O	P28	P20	116
I/O, SGCK2 <sup>(1)</sup> , GCK2 <sup>(2)</sup>	P29	P21	119
Not Connected <sup>(1)</sup> , M1 <sup>(2)</sup>	P30	P22	122
GND	P31	P23	-
MODE <sup>(1)</sup> , M0 <sup>(2)</sup>	P32	P24	125
VCC	P33	P25	-

### XCS05 and XCS05XL Device Pinouts

XCS05/XL Pad Name	PC84 <sup>(4)</sup>	VQ100	Bndry Scan
Not Connected <sup>(1)</sup> , PWRDWN <sup>(2)</sup>	P34	P26	126 <sup>(1)</sup>
I/O, PGCK2 <sup>(1)</sup> , GCK3 <sup>(2)</sup>	P35	P27	127 <sup>(3)</sup>
I/O (HDC)	P36	P28	130 <sup>(3)</sup>
I/O	-	P29	133 <sup>(3)</sup>
I/O (LDC)	P37	P30	136 <sup>(3)</sup>
I/O	P38	P31	139 <sup>(3)</sup>
I/O	P39	P32	142 <sup>(3)</sup>
I/O	-	P33	145 <sup>(3)</sup>
I/O	-	P34	148 <sup>(3)</sup>
I/O	P40	P35	151 <sup>(3)</sup>
I/O (INIT)	P41	P36	154 <sup>(3)</sup>
VCC	P42	P37	-
GND	P43	P38	-
I/O	P44	P39	157 <sup>(3)</sup>
I/O	P45	P40	160 <sup>(3)</sup>
I/O	-	P41	163 <sup>(3)</sup>
I/O	-	P42	166 <sup>(3)</sup>
I/O	P46	P43	169 <sup>(3)</sup>
I/O	P47	P44	172 <sup>(3)</sup>
I/O	P48	P45	175 <sup>(3)</sup>
I/O	P49	P46	178 <sup>(3)</sup>
I/O	P50	P47	181 <sup>(3)</sup>
I/O, SGCK3 <sup>(1)</sup> , GCK4 <sup>(2)</sup>	P51	P48	184 <sup>(3)</sup>
GND	P52	P49	-
DONE	P53	P50	-
VCC	P54	P51	-
PROGRAM	P55	P52	-
I/O (D7 <sup>(2)</sup> )	P56	P53	187 <sup>(3)</sup>
I/O, PGCK3 <sup>(1)</sup> , GCK5 <sup>(2)</sup>	P57	P54	190 <sup>(3)</sup>
I/O (D6 <sup>(2)</sup> )	P58	P55	193 <sup>(3)</sup>
I/O	-	P56	196 <sup>(3)</sup>
I/O (D5 <sup>(2)</sup> )	P59	P57	199 <sup>(3)</sup>
I/O	P60	P58	202 <sup>(3)</sup>
I/O	-	P59	205 <sup>(3)</sup>
I/O	-	P60	208 <sup>(3)</sup>
I/O (D4 <sup>(2)</sup> )	P61	P61	211 <sup>(3)</sup>
I/O	P62	P62	214 <sup>(3)</sup>
VCC	P63	P63	-
GND	P64	P64	-
I/O (D3 <sup>(2)</sup> )	P65	P65	217 <sup>(3)</sup>
I/O	P66	P66	220 <sup>(3)</sup>
I/O	-	P67	223 <sup>(3)</sup>
I/O (D2 <sup>(2)</sup> )	P67	P68	229 <sup>(3)</sup>
I/O	P68	P69	232 <sup>(3)</sup>
I/O (D1 <sup>(2)</sup> )	P69	P70	235 <sup>(3)</sup>

### XCS05 and XCS05XL Device Pinouts

XCS05/XL Pad Name	PC84 <sup>(4)</sup>	VQ100	Bndry Scan
I/O	P70	P71	238 <sup>(3)</sup>
I/O (D0 <sup>(2)</sup> , DIN)	P71	P72	241 <sup>(3)</sup>
I/O, SGCK4 <sup>(1)</sup> , GCK6 <sup>(2)</sup> (DOUT)	P72	P73	244 <sup>(3)</sup>
CCLK	P73	P74	-
VCC	P74	P75	-
O, TDO	P75	P76	0
GND	P76	P77	-
I/O	P77	P78	2
I/O, PGCK4 <sup>(1)</sup> , GCK7 <sup>(2)</sup>	P78	P79	5
I/O (CS1 <sup>(2)</sup> )	P79	P80	8
I/O	P80	P81	11
I/O	P81	P82	14
I/O	P82	P83	17
I/O	-	P84	20
I/O	-	P85	23
I/O	P83	P86	26
I/O	P84	P87	29
GND	P1	P88	-

**Notes:**

1. 5V Spartan family only
2. 3V Spartan-XL family only
3. The "PWRDWN" on the XCS05XL is not part of the Boundary Scan chain. For the XCS05XL, subtract 1 from all Boundary Scan numbers from GCK3 on (127 and higher).
4. PC84 package discontinued by [PDN2004-01](#)

### XCS10 and XCS10XL Device Pinouts

XCS10/XL Pad Name	PC84 <sup>(4)</sup>	VQ100	CS144 <sup>(2,4)</sup>	TQ144	Bndry Scan
VCC	P2	P89	D7	P128	-
I/O	P3	P90	A6	P129	44
I/O	P4	P91	B6	P130	47
I/O	-	P92	C6	P131	50
I/O	-	P93	D6	P132	53
I/O	P5	P94	A5	P133	56
I/O	P6	P95	B5	P134	59
I/O	-	-	C5	P135	62
I/O	-	-	D5	P136	65
GND	-	-	A4	P137	-
I/O	P7	P96	B4	P138	68
I/O	P8	P97	C4	P139	71
I/O	-	-	A3	P140	74
I/O	-	-	B3	P141	77
I/O	P9	P98	C3	P142	80

### XCS10 and XCS10XL Device Pinouts

XCS10/XL Pad Name	PC84 <sup>(4)</sup>	VQ100	CS144 <sup>(2,4)</sup>	TQ144	Bndry Scan
I/O, SGCK1 <sup>(1)</sup> GCK8 <sup>(2)</sup>	P10	P99	A2	P143	83
VCC	P11	P100	B2	P144	-
GND	P12	P1	A1	P1	-
I/O, PGCK1 <sup>(1)</sup> GCK1 <sup>(2)</sup>	P13	P2	B1	P2	86
I/O	P14	P3	C2	P3	89
I/O	-	-	C1	P4	92
I/O	-	-	D4	P5	95
I/O, TDI	P15	P4	D3	P6	98
I/O, TCK	P16	P5	D2	P7	101
GND	-	-	D1	P8	-
I/O	-	-	E4	P9	104
I/O	-	-	E3	P10	107
I/O, TMS	P17	P6	E2	P11	110
I/O	P18	P7	E1	P12	113
I/O	-	-	F4	P13	116
I/O	-	P8	F3	P14	119
I/O	P19	P9	F2	P15	122
I/O	P20	P10	F1	P16	125
GND	P21	P11	G2	P17	-
VCC	P22	P12	G1	P18	-
I/O	P23	P13	G3	P19	128
I/O	P24	P14	G4	P20	131
I/O	-	P15	H1	P21	134
I/O	-	-	H2	P22	137
I/O	P25	P16	H3	P23	140
I/O	P26	P17	H4	P24	143
I/O	-	-	J1	P25	146
I/O	-	-	J2	P26	149
GND	-	-	J3	P27	-
I/O	P27	P18	J4	P28	152
I/O	-	P19	K1	P29	155
I/O	-	-	K2	P30	158
I/O	-	-	K3	P31	161
I/O	P28	P20	L1	P32	164
I/O, SGCK2 <sup>(1)</sup> GCK2 <sup>(2)</sup>	P29	P21	L2	P33	167
Not Connected <sup>(1)</sup> M1 <sup>(2)</sup>	P30	P22	L3	P34	170
GND	P31	P23	M1	P35	-
MODE <sup>(1)</sup> , M0 <sup>(2)</sup>	P32	P24	M2	P36	173

## XCS10 and XCS10XL Device Pinouts

XCS10/XL Pad Name	PC84(4)	VQ100	CS144(2,4)	TQ144	Bndry Scan
VCC	P33	P25	N1	P37	-
Not Connected <sup>(1)</sup>	P34	P26	N2	P38	174 <sup>(1)</sup>
PWRDWN <sup>(2)</sup>					
I/O, PGCK2 <sup>(1)</sup> GCK3 <sup>(2)</sup>	P35	P27	M3	P39	175 <sup>(3)</sup>
I/O (HDC)	P36	P28	N3	P40	178 <sup>(3)</sup>
I/O	-	-	K4	P41	181 <sup>(3)</sup>
I/O	-	-	L4	P42	184 <sup>(3)</sup>
I/O	-	P29	M4	P43	187 <sup>(3)</sup>
I/O (LDC)	P37	P30	N4	P44	190 <sup>(3)</sup>
GND	-	-	K5	P45	-
I/O	-	-	L5	P46	193 <sup>(3)</sup>
I/O	-	-	M5	P47	196 <sup>(3)</sup>
I/O	P38	P31	N5	P48	199 <sup>(3)</sup>
I/O	P39	P32	K6	P49	202 <sup>(3)</sup>
I/O	-	P33	L6	P50	205 <sup>(3)</sup>
I/O	-	P34	M6	P51	208 <sup>(3)</sup>
I/O	P40	P35	N6	P52	211 <sup>(3)</sup>
I/O (INIT)	P41	P36	M7	P53	214 <sup>(3)</sup>
VCC	P42	P37	N7	P54	-
GND	P43	P38	L7	P55	-
I/O	P44	P39	K7	P56	217 <sup>(3)</sup>
I/O	P45	P40	N8	P57	220 <sup>(3)</sup>
I/O	-	P41	M8	P58	223 <sup>(3)</sup>
I/O	-	P42	L8	P59	226 <sup>(3)</sup>
I/O	P46	P43	K8	P60	229 <sup>(3)</sup>
I/O	P47	P44	N9	P61	232 <sup>(3)</sup>
I/O	-	-	M9	P62	235 <sup>(3)</sup>
I/O	-	-	L9	P63	238 <sup>(3)</sup>
GND	-	-	K9	P64	-
I/O	P48	P45	N10	P65	241 <sup>(3)</sup>
I/O	P49	P46	M10	P66	244 <sup>(3)</sup>
I/O	-	-	L10	P67	247 <sup>(3)</sup>
I/O	-	-	N11	P68	250 <sup>(3)</sup>
I/O	P50	P47	M11	P69	253 <sup>(3)</sup>
I/O, SGCK3 <sup>(1)</sup> GCK4 <sup>(2)</sup>	P51	P48	L11	P70	256 <sup>(3)</sup>
GND	P52	P49	N12	P71	-
DONE	P53	P50	M12	P72	-
VCC	P54	P51	N13	P73	-
PROGRAM	P55	P52	M13	P74	-
I/O (D7 <sup>(2)</sup> )	P56	P53	L12	P75	259 <sup>(3)</sup>

## XCS10 and XCS10XL Device Pinouts

XCS10/XL Pad Name	PC84(4)	VQ100	CS144(2,4)	TQ144	Bndry Scan
I/O, PGCK3 <sup>(1)</sup> GCK5 <sup>(2)</sup>	P57	P54	L13	P76	262 <sup>(3)</sup>
I/O	-	-	K10	P77	265 <sup>(3)</sup>
I/O	-	-	K11	P78	268 <sup>(3)</sup>
I/O (D6 <sup>(2)</sup> )	P58	P55	K12	P79	271 <sup>(3)</sup>
I/O	-	P56	K13	P80	274 <sup>(3)</sup>
GND	-	-	J10	P81	-
I/O	-	-	J11	P82	277 <sup>(3)</sup>
I/O	-	-	J12	P83	280 <sup>(3)</sup>
I/O (D5 <sup>(2)</sup> )	P59	P57	J13	P84	283 <sup>(3)</sup>
I/O	P60	P58	H10	P85	286 <sup>(3)</sup>
I/O	-	P59	H11	P86	289 <sup>(3)</sup>
I/O	-	P60	H12	P87	292 <sup>(3)</sup>
I/O (D4 <sup>(2)</sup> )	P61	P61	H13	P88	295 <sup>(3)</sup>
I/O	P62	P62	G12	P89	298 <sup>(3)</sup>
VCC	P63	P63	G13	P90	-
GND	P64	P64	G11	P91	-
I/O (D3 <sup>(2)</sup> )	P65	P65	G10	P92	301 <sup>(3)</sup>
I/O	P66	P66	F13	P93	304 <sup>(3)</sup>
I/O	-	P67	F12	P94	307 <sup>(3)</sup>
I/O	-	-	F11	P95	310 <sup>(3)</sup>
I/O (D2 <sup>(2)</sup> )	P67	P68	F10	P96	313 <sup>(3)</sup>
I/O	P68	P69	E13	P97	316 <sup>(3)</sup>
I/O	-	-	E12	P98	319 <sup>(3)</sup>
I/O	-	-	E11	P99	322 <sup>(3)</sup>
GND	-	-	E10	P100	-
I/O (D1 <sup>(2)</sup> )	P69	P70	D13	P101	325 <sup>(3)</sup>
I/O	P70	P71	D12	P102	328 <sup>(3)</sup>
I/O	-	-	D11	P103	331 <sup>(3)</sup>
I/O	-	-	C13	P104	334 <sup>(3)</sup>
I/O (D0 <sup>(2)</sup> , DIN)	P71	P72	C12	P105	337 <sup>(3)</sup>
I/O, SGCK4 <sup>(1)</sup> GCK6 <sup>(2)</sup> (DOUT)	P72	P73	C11	P106	340 <sup>(3)</sup>
CCLK	P73	P74	B13	P107	-
VCC	P74	P75	B12	P108	-
O, TDO	P75	P76	A13	P109	0
GND	P76	P77	A12	P110	-
I/O	P77	P78	B11	P111	2
I/O, PGCK4 <sup>(1)</sup> GCK7 <sup>(2)</sup>	P78	P79	A11	P112	5
I/O	-	-	D10	P113	8
I/O	-	-	C10	P114	11
I/O (CS1 <sup>(2)</sup> )	P79	P80	B10	P115	14

### XCS10 and XCS10XL Device Pinouts

XCS10/XL Pad Name	PC84 <sup>(4)</sup>	VQ100	CS144 <sup>(2,4)</sup>	TQ144	Bndry Scan
I/O	P80	P81	A10	P116	17
GND	-	-	C9	P118	-
I/O	-	-	B9	P119	20
I/O	-	-	A9	P120	23
I/O	P81	P82	D8	P121	26
I/O	P82	P83	C8	P122	29
I/O	-	P84	B8	P123	32
I/O	-	P85	A8	P124	35
I/O	P83	P86	B7	P125	38
I/O	P84	P87	A7	P126	41
GND	P1	P88	C7	P127	-

**Notes:**

1. 5V Spartan family only
2. 3V Spartan-XL family only
3. The "PWRDWN" on the XCS10XL is not part of the Boundary Scan chain. For the XCS10XL, subtract 1 from all Boundary Scan numbers from GCK3 on (175 and higher).
4. PC84 and CS144 packages discontinued by [PDN2004-01](#)

### Additional XCS10/XL Package Pins

TQ144					
Not Connected Pins					
P117	-	-	-	-	-
5/5/97					

CS144					
Not Connected Pins					
D9	-	-	-	-	-
4/28/99					

### XCS20 and XCS20XL Device Pinouts

XCS20/XL Pad Name	VQ100	CS144 <sup>(2,4)</sup>	TQ144	PQ208	Bndry Scan
VCC	P89	D7	P128	P183	-
I/O	P90	A6	P129	P184	62
I/O	P91	B6	P130	P185	65
I/O	P92	C6	P131	P186	68
I/O	P93	D6	P132	P187	71
I/O	-	-	-	P188	74
I/O	-	-	-	P189	77
I/O	P94	A5	P133	P190	80
I/O	P95	B5	P134	P191	83
VCC <sup>(2)</sup>	-	-	-	P192	-
I/O	-	C5	P135	P193	86
I/O	-	D5	P136	P194	89
GND	-	A4	P137	P195	-
I/O	-	-	-	P196	92
I/O	-	-	-	P197	95
I/O	-	-	-	P198	98
I/O	-	-	-	P199	101
I/O	P96	B4	P138	P200	104
I/O	P97	C4	P139	P201	107
I/O	-	A3	P140	P204	110
I/O	-	B3	P141	P205	113
I/O	P98	C3	P142	P206	116

### XCS20 and XCS20XL Device Pinouts

XCS20/XL Pad Name	VQ100	CS144 <sup>(2,4)</sup>	TQ144	PQ208	Bndry Scan
I/O, SGCK1 <sup>(1)</sup> , GCK8 <sup>(2)</sup>	P99	A2	P143	P207	119
VCC	P100	B2	P144	P208	-
GND	P1	A1	P1	P1	-
I/O, PGCK1 <sup>(1)</sup> , GCK1 <sup>(2)</sup>	P2	B1	P2	P2	122
I/O	P3	C2	P3	P3	125
I/O	-	C1	P4	P4	128
I/O	-	D4	P5	P5	131
I/O, TDI	P4	D3	P6	P6	134
I/O, TCK	P5	D2	P7	P7	137
I/O	-	-	-	P8	140
I/O	-	-	-	P9	143
I/O	-	-	-	P10	146
I/O	-	-	-	P11	149
GND	-	D1	P8	P13	-
I/O	-	E4	P9	P14	152
I/O	-	E3	P10	P15	155
I/O, TMS	P6	E2	P11	P16	158
I/O	P7	E1	P12	P17	161
VCC <sup>(2)</sup>	-	-	-	P18	-
I/O	-	-	-	P19	164
I/O	-	-	-	P20	167

**XCS20 and XCS20XL Device Pinouts**

XCS20/XL Pad Name	VQ100	CS144 <sup>(2,4)</sup>	TQ144	PQ208	Bndry Scan
I/O	-	F4	P13	P21	170
I/O	P8	F3	P14	P22	173
I/O	P9	F2	P15	P23	176
I/O	P10	F1	P16	P24	179
GND	P11	G2	P17	P25	-
VCC	P12	G1	P18	P26	-
I/O	P13	G3	P19	P27	182
I/O	P14	G4	P20	P28	185
I/O	P15	H1	P21	P29	188
I/O	-	H2	P22	P30	191
I/O	-	-	-	P31	194
I/O	-	-	-	P32	197
VCC <sup>(2)</sup>	-	-	-	P33	-
I/O	P16	H3	P23	P34	200
I/O	P17	H4	P24	P35	203
I/O	-	J1	P25	P36	206
I/O	-	J2	P26	P37	209
GND	-	J3	P27	P38	-
I/O	-	-	-	P40	212
I/O	-	-	-	P41	215
I/O	-	-	-	P42	218
I/O	-	-	-	P43	221
I/O	P18	J4	P28	P44	224
I/O	P19	K1	P29	P45	227
I/O	-	K2	P30	P46	230
I/O	-	K3	P31	P47	233
I/O	P20	L1	P32	P48	236
I/O, SGCK2 <sup>(1)</sup> , GCK2 <sup>(2)</sup>	P21	L2	P33	P49	239
Not Connected <sup>(1)</sup> M1 <sup>(2)</sup>	P22	L3	P34	P50	242
GND	P23	M1	P35	P51	-
MODE <sup>(1)</sup> , M0 <sup>(2)</sup>	P24	M2	P36	P52	245
VCC	P25	N1	P37	P53	-
Not Connected <sup>(1)</sup> PWRDWN <sup>(2)</sup>	P26	N2	P38	P54	246 <sup>(1)</sup>
I/O, PGCK2 <sup>(1)</sup> , GCK3 <sup>(2)</sup>	P27	M3	P39	P55	247 <sup>(3)</sup>
I/O (HDC)	P28	N3	P40	P56	250 <sup>(3)</sup>
I/O	-	K4	P41	P57	253 <sup>(3)</sup>
I/O	-	L4	P42	P58	256 <sup>(3)</sup>
I/O	P29	M4	P43	P59	259 <sup>(3)</sup>

**XCS20 and XCS20XL Device Pinouts**

XCS20/XL Pad Name	VQ100	CS144 <sup>(2,4)</sup>	TQ144	PQ208	Bndry Scan
I/O (LDC)	P30	N4	P44	P60	262 <sup>(3)</sup>
I/O	-	-	-	P61	265 <sup>(3)</sup>
I/O	-	-	-	P62	268 <sup>(3)</sup>
I/O	-	-	-	P63	271 <sup>(3)</sup>
I/O	-	-	-	P64	274 <sup>(3)</sup>
GND	-	K5	P45	P66	-
I/O	-	L5	P46	P67	277 <sup>(3)</sup>
I/O	-	M5	P47	P68	280 <sup>(3)</sup>
I/O	P31	N5	P48	P69	283 <sup>(3)</sup>
I/O	P32	K6	P49	P70	286 <sup>(3)</sup>
VCC <sup>(2)</sup>	-	-	-	P71	-
I/O	-	-	-	P72	289 <sup>(3)</sup>
I/O	-	-	-	P73	292 <sup>(3)</sup>
I/O	P33	L6	P50	P74	295 <sup>(3)</sup>
I/O	P34	M6	P51	P75	298 <sup>(3)</sup>
I/O	P35	N6	P52	P76	301 <sup>(3)</sup>
I/O (INIT)	P36	M7	P53	P77	304 <sup>(3)</sup>
VCC	P37	N7	P54	P78	-
GND	P38	L7	P55	P79	-
I/O	P39	K7	P56	P80	307 <sup>(3)</sup>
I/O	P40	N8	P57	P81	310 <sup>(3)</sup>
I/O	P41	M8	P58	P82	313 <sup>(3)</sup>
I/O	P42	L8	P59	P83	316 <sup>(3)</sup>
I/O	-	-	-	P84	319 <sup>(3)</sup>
I/O	-	-	-	P85	322 <sup>(3)</sup>
VCC <sup>(2)</sup>	-	-	-	P86	-
I/O	P43	K8	P60	P87	325 <sup>(3)</sup>
I/O	P44	N9	P61	P88	328 <sup>(3)</sup>
I/O	-	M9	P62	P89	331 <sup>(3)</sup>
I/O	-	L9	P63	P90	334 <sup>(3)</sup>
GND	-	K9	P64	P91	-
I/O	-	-	-	P93	337 <sup>(3)</sup>
I/O	-	-	-	P94	340 <sup>(3)</sup>
I/O	-	-	-	P95	343 <sup>(3)</sup>
I/O	-	-	-	P96	346 <sup>(3)</sup>
I/O	P45	N10	P65	P97	349 <sup>(3)</sup>
I/O	P46	M10	P66	P98	352 <sup>(3)</sup>
I/O	-	L10	P67	P99	355 <sup>(3)</sup>
I/O	-	N11	P68	P100	358 <sup>(3)</sup>
I/O	P47	M11	P69	P101	361 <sup>(3)</sup>
I/O, SGCK3 <sup>(1)</sup> , GCK4 <sup>(2)</sup>	P48	L11	P70	P102	364 <sup>(3)</sup>
GND	P49	N12	P71	P103	-
DONE	P50	M12	P72	P104	-
VCC	P51	N13	P73	P105	-

**XCS20 and XCS20XL Device Pinouts**

XCS20/XL Pad Name	VQ100	CS144 <sup>(2,4)</sup>	TQ144	PQ208	Bndry Scan
PROGRAM	P52	M13	P74	P106	-
I/O (D7 <sup>(2)</sup> )	P53	L12	P75	P107	367 <sup>(3)</sup>
I/O, PGCK3 <sup>(1)</sup> , GCK5 <sup>(2)</sup>	P54	L13	P76	P108	370 <sup>(3)</sup>
I/O	-	K10	P77	P109	373 <sup>(3)</sup>
I/O	-	K11	P78	P110	376 <sup>(3)</sup>
I/O (D6 <sup>(2)</sup> )	P55	K12	P79	P112	379 <sup>(3)</sup>
I/O	P56	K13	P80	P113	382 <sup>(3)</sup>
I/O	-	-	-	P114	385 <sup>(3)</sup>
I/O	-	-	-	P115	388 <sup>(3)</sup>
I/O	-	-	-	P116	391 <sup>(3)</sup>
I/O	-	-	-	P117	394 <sup>(3)</sup>
GND	-	J10	P81	P118	-
I/O	-	J11	P82	P119	397 <sup>(3)</sup>
I/O	-	J12	P83	P120	400 <sup>(3)</sup>
VCC <sup>(2)</sup>	-	-	-	P121	-
I/O (D5 <sup>(2)</sup> )	P57	J13	P84	P122	403 <sup>(3)</sup>
I/O	P58	H10	P85	P123	406 <sup>(3)</sup>
I/O	-	-	-	P124	409 <sup>(3)</sup>
I/O	-	-	-	P125	412 <sup>(3)</sup>
I/O	P59	H11	P86	P126	415 <sup>(3)</sup>
I/O	P60	H12	P87	P127	418 <sup>(3)</sup>
I/O (D4 <sup>(2)</sup> )	P61	H13	P88	P128	421 <sup>(3)</sup>
I/O	P62	G12	P89	P129	424 <sup>(3)</sup>
VCC	P63	G13	P90	P130	-
GND	P64	G11	P91	P131	-
I/O (D3 <sup>(2)</sup> )	P65	G10	P92	P132	427 <sup>(3)</sup>
I/O	P66	F13	P93	P133	430 <sup>(3)</sup>
I/O	P67	F12	P94	P134	433 <sup>(3)</sup>
I/O	-	F11	P95	P135	436 <sup>(3)</sup>
I/O	-	-	-	P136	439 <sup>(3)</sup>
I/O	-	-	-	P137	442 <sup>(3)</sup>
I/O (D2 <sup>(2)</sup> )	P68	F10	P96	P138	445 <sup>(3)</sup>
I/O	P69	E13	P97	P139	448 <sup>(3)</sup>
VCC <sup>(2)</sup>	-	-	-	P140	-
I/O	-	E12	P98	P141	451 <sup>(3)</sup>
I/O	-	E11	P99	P142	454 <sup>(3)</sup>
GND	-	E10	P100	P143	-
I/O	-	-	-	P145	457 <sup>(3)</sup>
I/O	-	-	-	P146	460 <sup>(3)</sup>
I/O	-	-	-	P147	463 <sup>(3)</sup>
I/O	-	-	-	P148	466 <sup>(3)</sup>
I/O (D1 <sup>(2)</sup> )	P70	D13	P101	P149	469 <sup>(3)</sup>
I/O	P71	D12	P102	P150	472 <sup>(3)</sup>
I/O	-	D11	P103	P151	475 <sup>(3)</sup>

**XCS20 and XCS20XL Device Pinouts**

XCS20/XL Pad Name	VQ100	CS144 <sup>(2,4)</sup>	TQ144	PQ208	Bndry Scan
I/O	-	C13	P104	P152	478 <sup>(3)</sup>
I/O (D0 <sup>(2)</sup> , DIN)	P72	C12	P105	P153	481 <sup>(3)</sup>
I/O, SGCK4 <sup>(1)</sup> , GCK6 <sup>(2)</sup> (DOUT)	P73	C11	P106	P154	484 <sup>(3)</sup>
CCLK	P74	B13	P107	P155	-
VCC	P75	B12	P108	P156	-
O, TDO	P76	A13	P109	P157	0
GND	P77	A12	P110	P158	-
I/O	P78	B11	P111	P159	2
I/O, PGCK4 <sup>(1)</sup> , GCK7 <sup>(2)</sup>	P79	A11	P112	P160	5
I/O	-	D10	P113	P161	8
I/O	-	C10	P114	P162	11
I/O (CS1 <sup>(2)</sup> )	P80	B10	P115	P163	14
I/O	P81	A10	P116	P164	17
I/O	-	D9	P117	P166	20
I/O	-	-	-	P167	23
I/O	-	-	-	P168	26
I/O	-	-	-	P169	29
GND	-	C9	P118	P170	-
I/O	-	B9	P119	P171	32
I/O	-	A9	P120	P172	35
VCC <sup>(2)</sup>	-	-	-	P173	-
I/O	P82	D8	P121	P174	38
I/O	P83	C8	P122	P175	41
I/O	-	-	-	P176	44
I/O	-	-	-	P177	47
I/O	P84	B8	P123	P178	50
I/O	P85	A8	P124	P179	53
I/O	P86	B7	P125	P180	56
I/O	P87	A7	P126	P181	59
GND	P88	C7	P127	P182	-

2/8/00

**Additional XCS20/XL Package Pins**

PQ208					
Not Connected Pins					
P12	P18 (1)	P33 (1)	P39	P65	P71 (1)
P86 (1)	P92	P111	P121(1)	P140(1)	P144
P165	P173(1)	P192(1)	P202	P203	-

9/16/98

**Notes:**

1. 5V Spartan family only
2. 3V Spartan-XL family only
3. The "PWRDWN" on the XCS20XL is not part of the Boundary Scan chain. For the XCS20XL, subtract 1 from all Boundary Scan numbers from GCK3 on (247 and higher).
4. CS144 package discontinued by [PDN2004-01](#)

**XCS30 and XCS30XL Device Pinouts**

XCS30/XL Pad Name	VQ100(5)	TQ144	PQ208	PQ240	BG256(5)	CS280(2,5)	Bndry Scan
VCC	P89	P128	P183	P212	VCC(4)	C10	-
I/O	P90	P129	P184	P213	C10	D10	74
I/O	P91	P130	P185	P214	D10	E10	77
I/O	P92	P131	P186	P215	A9	A9	80
I/O	P93	P132	P187	P216	B9	B9	83
I/O	-	-	P188	P217	C9	C9	86
I/O	-	-	P189	P218	D9	D9	89
I/O	P94	P133	P190	P220	A8	A8	92
I/O	P95	P134	P191	P221	B8	B8	95
VCC	-	-	P192	P222	VCC(4)	A7	-
I/O	-	-	-	P223	A6	B7	98
I/O	-	-	-	P224	C7	C7	101
I/O	-	P135	P193	P225	B6	D7	104
I/O	-	P136	P194	P226	A5	A6	107
GND	-	P137	P195	P227	GND(4)	GND(4)	-
I/O	-	-	P196	P228	C6	B6	110
I/O	-	-	P197	P229	B5	C6	113
I/O	-	-	P198	P230	A4	D6	116
I/O	-	-	P199	P231	C5	E6	119
I/O	P96	P138	P200	P232	B4	A5	122
I/O	P97	P139	P201	P233	A3	C5	125
I/O	-	-	P202	P234	D5	B4	128
I/O	-	-	P203	P235	C4	C4	131
I/O	-	P140	P204	P236	B3	A3	134
I/O	-	P141	P205	P237	B2	A2	137
I/O	P98	P142	P206	P238	A2	B3	140
I/O, SGCK1(1), GCK8(2)	P99	P143	P207	P239	C3	B2	143
VCC	P100	P144	P208	P240	VCC(4)	A1	-
GND	P1	P1	P1	P1	GND(4)	GND(4)	-
I/O, PGCK1(1), GCK1(2)	P2	P2	P2	P2	B1	C3	146
I/O	P3	P3	P3	P3	C2	C2	149
I/O	-	P4	P4	P4	D2	B1	152

## XCS30 and XCS30XL Device Pinouts (Continued)

XCS30/XL Pad Name	VQ100 <sup>(5)</sup>	TQ144	PQ208	PQ240	BG256 <sup>(5)</sup>	CS280 <sup>(2,5)</sup>	Bndry Scan
I/O	-	P5	P5	P5	D3	C1	155
I/O, TDI	P4	P6	P6	P6	E4	D4	158
I/O, TCK	P5	P7	P7	P7	C1	D3	161
I/O	-	-	P8	P8	D1	E2	164
I/O	-	-	P9	P9	E3	E4	167
I/O	-	-	P10	P10	E2	E1	170
I/O	-	-	P11	P11	E1	F5	173
I/O	-	-	P12	P12	F3	F3	176
I/O	-	-	-	P13	F2	F2	179
GND	-	P8	P13	P14	GND <sup>(4)</sup>	GND <sup>(4)</sup>	-
I/O	-	P9	P14	P15	G3	F4	182
I/O	-	P10	P15	P16	G2	F1	185
I/O, TMS	P6	P11	P16	P17	G1	G3	188
I/O	P7	P12	P17	P18	H3	G2	191
VCC	-	-	P18	P19	VCC <sup>(4)</sup>	G1	-
I/O	-	-	-	P20	H2	G4	194
I/O	-	-	-	P21	H1	H1	197
I/O	-	-	P19	P23	J2	H4	200
I/O	-	-	P20	P24	J1	J1	203
I/O	-	P13	P21	P25	K2	J2	206
I/O	P8	P14	P22	P26	K3	J3	209
I/O	P9	P15	P23	P27	K1	J4	212
I/O	P10	P16	P24	P28	L1	K1	215
GND	P11	P17	P25	P29	GND <sup>(4)</sup>	GND <sup>(4)</sup>	-
VCC	P12	P18	P26	P30	VCC <sup>(4)</sup>	K2	-
I/O	P13	P19	P27	P31	L2	K3	218
I/O	P14	P20	P28	P32	L3	K4	221
I/O	P15	P21	P29	P33	L4	K5	224
I/O	-	P22	P30	P34	M1	L1	227
I/O	-	-	P31	P35	M2	L2	230
I/O	-	-	P32	P36	M3	L3	233
I/O	-	-	-	P38	N1	M2	236
I/O	-	-	-	P39	N2	M3	239
VCC	-	-	P33	P40	VCC <sup>(4)</sup>	M4	-
I/O	P16	P23	P34	P41	P1	N1	242
I/O	P17	P24	P35	P42	P2	N2	245
I/O	-	P25	P36	P43	R1	N3	248
I/O	-	P26	P37	P44	P3	N4	251
GND	-	P27	P38	P45	GND <sup>(4)</sup>	GND <sup>(4)</sup>	-
I/O	-	-	-	P46	T1	P1	254
I/O	-	-	P39	P47	R3	P2	257
I/O	-	-	P40	P48	T2	P3	260
I/O	-	-	P41	P49	U1	P4	263
I/O	-	-	P42	P50	T3	P5	266
I/O	-	-	P43	P51	U2	R1	269

## XCS30 and XCS30XL Device Pinouts (Continued)

XCS30/XL Pad Name	VQ100 <sup>(5)</sup>	TQ144	PQ208	PQ240	BG256 <sup>(5)</sup>	CS280 <sup>(2,5)</sup>	Bndry Scan
I/O	P18	P28	P44	P52	V1	T1	272
I/O	P19	P29	P45	P53	T4	T2	275
I/O	-	P30	P46	P54	U3	T3	278
I/O	-	P31	P47	P55	V2	U1	281
I/O	P20	P32	P48	P56	W1	V1	284
I/O, SGCK2 <sup>(1)</sup> , GCK2 <sup>(2)</sup>	P21	P33	P49	P57	V3	U2	287
Not Connected <sup>(1)</sup> , M1 <sup>(2)</sup>	P22	P34	P50	P58	W2	V2	290
GND	P23	P35	P51	P59	GND <sup>(4)</sup>	GND <sup>(4)</sup>	-
MODE <sup>(1)</sup> , M0 <sup>(2)</sup>	P24	P36	P52	P60	Y1	W1	293
VCC	P25	P37	P53	P61	VCC <sup>(4)</sup>	U3	-
Not Connected <sup>(1)</sup> , PWRDWN <sup>(2)</sup>	P26	P38	P54	P62	W3	V3	294 <sup>(1)</sup>
I/O, PGCK2 <sup>(1)</sup> , GCK3 <sup>(2)</sup>	P27	P39	P55	P63	Y2	W2	295 <sup>(3)</sup>
I/O (HDC)	P28	P40	P56	P64	W4	W3	298 <sup>(3)</sup>
I/O	-	P41	P57	P65	V4	T4	301 <sup>(3)</sup>
I/O	-	P42	P58	P66	U5	U4	304 <sup>(3)</sup>
I/O	P29	P43	P59	P67	Y3	V4	307 <sup>(3)</sup>
I/O (LDC)	P30	P44	P60	P68	Y4	W4	310 <sup>(3)</sup>
I/O	-	-	P61	P69	V5	T5	313 <sup>(3)</sup>
I/O	-	-	P62	P70	W5	W5	316 <sup>(3)</sup>
I/O	-	-	P63	P71	Y5	R6	319 <sup>(3)</sup>
I/O	-	-	P64	P72	V6	U6	322 <sup>(3)</sup>
I/O	-	-	P65	P73	W6	V6	325 <sup>(3)</sup>
I/O	-	-	-	P74	Y6	T6	328 <sup>(3)</sup>
GND	-	P45	P66	P75	GND <sup>(4)</sup>	GND <sup>(4)</sup>	-
I/O	-	P46	P67	P76	W7	W6	331 <sup>(3)</sup>
I/O	-	P47	P68	P77	Y7	U7	334 <sup>(3)</sup>
I/O	P31	P48	P69	P78	V8	V7	337 <sup>(3)</sup>
I/O	P32	P49	P70	P79	W8	W7	340 <sup>(3)</sup>
VCC	-	-	P71	P80	VCC <sup>(4)</sup>	T7	-
I/O	-	-	P72	P81	Y8	W8	343 <sup>(3)</sup>
I/O	-	-	P73	P82	U9	U8	346 <sup>(3)</sup>
I/O	-	-	-	P84	Y9	W9	349 <sup>(3)</sup>
I/O	-	-	-	P85	W10	V9	352 <sup>(3)</sup>
I/O	P33	P50	P74	P86	V10	U9	355 <sup>(3)</sup>
I/O	P34	P51	P75	P87	Y10	T9	358 <sup>(3)</sup>
I/O	P35	P52	P76	P88	Y11	W10	361 <sup>(3)</sup>
I/O (INIT)	P36	P53	P77	P89	W11	V10	364 <sup>(3)</sup>
VCC	P37	P54	P78	P90	VCC <sup>(4)</sup>	U10	-
GND	P38	P55	P79	P91	GND <sup>(4)</sup>	GND <sup>(4)</sup>	-
I/O	P39	P56	P80	P92	V11	T10	367 <sup>(3)</sup>
I/O	P40	P57	P81	P93	U11	R10	370 <sup>(3)</sup>
I/O	P41	P58	P82	P94	Y12	W11	373 <sup>(3)</sup>
I/O	P42	P59	P83	P95	W12	V11	376 <sup>(3)</sup>
I/O	-	-	P84	P96	V12	U11	379 <sup>(3)</sup>

## XCS30 and XCS30XL Device Pinouts (Continued)

XCS30/XL Pad Name	VQ100 <sup>(5)</sup>	TQ144	PQ208	PQ240	BG256 <sup>(5)</sup>	CS280 <sup>(2,5)</sup>	Bndry Scan
I/O	-	-	P85	P97	U12	T11	382 <sup>(3)</sup>
I/O	-	-	-	P99	V13	U12	385 <sup>(3)</sup>
I/O	-	-	-	P100	Y14	T12	388 <sup>(3)</sup>
VCC	-	-	P86	P101	VCC <sup>(4)</sup>	W13	-
I/O	P43	P60	P87	P102	Y15	V13	391 <sup>(3)</sup>
I/O	P44	P61	P88	P103	V14	U13	394 <sup>(3)</sup>
I/O	-	P62	P89	P104	W15	T13	397 <sup>(3)</sup>
I/O	-	P63	P90	P105	Y16	W14	400 <sup>(3)</sup>
GND	-	P64	P91	P106	GND <sup>(4)</sup>	GND <sup>(4)</sup>	-
I/O	-	-	-	P107	V15	V14	403 <sup>(3)</sup>
I/O	-	-	P92	P108	W16	U14	406 <sup>(3)</sup>
I/O	-	-	P93	P109	Y17	T14	409 <sup>(3)</sup>
I/O	-	-	P94	P110	V16	R14	412 <sup>(3)</sup>
I/O	-	-	P95	P111	W17	W15	415 <sup>(3)</sup>
I/O	-	-	P96	P112	Y18	U15	418 <sup>(3)</sup>
I/O	P45	P65	P97	P113	U16	V16	421 <sup>(3)</sup>
I/O	P46	P66	P98	P114	V17	U16	424 <sup>(3)</sup>
I/O	-	P67	P99	P115	W18	W17	427 <sup>(3)</sup>
I/O	-	P68	P100	P116	Y19	W18	430 <sup>(3)</sup>
I/O	P47	P69	P101	P117	V18	V17	433 <sup>(3)</sup>
I/O, SGCK3 <sup>(1)</sup> , GCK4 <sup>(2)</sup>	P48	P70	P102	P118	W19	V18	436 <sup>(3)</sup>
GND	P49	P71	P103	P119	GND <sup>(4)</sup>	GND <sup>(4)</sup>	-
DONE	P50	P72	P104	P120	Y20	W19	-
VCC	P51	P73	P105	P121	VCC <sup>(4)</sup>	U17	-
PROGRAM	P52	P74	P106	P122	V19	U18	-
I/O (D7 <sup>(2)</sup> )	P53	P75	P107	P123	U19	V19	439 <sup>(3)</sup>
I/O, PGCK3 <sup>(1)</sup> , GCK5 <sup>(2)</sup>	P54	P76	P108	P124	U18	U19	442 <sup>(3)</sup>
I/O	-	P77	P109	P125	T17	T16	445 <sup>(3)</sup>
I/O	-	P78	P110	P126	V20	T17	448 <sup>(3)</sup>
I/O	-	-	-	P127	U20	T18	451 <sup>(3)</sup>
I/O	-	-	P111	P128	T18	T19	454 <sup>(3)</sup>
I/O (D6 <sup>(2)</sup> )	P55	P79	P112	P129	T19	R16	457 <sup>(3)</sup>
I/O	P56	P80	P113	P130	T20	R19	460 <sup>(3)</sup>
I/O	-	-	P114	P131	R18	P15	463 <sup>(3)</sup>
I/O	-	-	P115	P132	R19	P17	466 <sup>(3)</sup>
I/O	-	-	P116	P133	R20	P18	469 <sup>(3)</sup>
I/O	-	-	P117	P134	P18	P16	472 <sup>(3)</sup>
GND	-	P81	P118	P135	GND <sup>(4)</sup>	GND <sup>(4)</sup>	-
I/O	-	-	-	P136	P20	P19	475 <sup>(3)</sup>
I/O	-	-	-	P137	N18	N17	478 <sup>(3)</sup>
I/O	-	P82	P119	P138	N19	N18	481 <sup>(3)</sup>
I/O	-	P83	P120	P139	N20	N19	484 <sup>(3)</sup>
VCC	-	-	P121	P140	VCC <sup>(4)</sup>	N16	-
I/O (D5 <sup>(2)</sup> )	P57	P84	P122	P141	M17	M19	487 <sup>(3)</sup>
I/O	P58	P85	P123	P142	M18	M17	490 <sup>(3)</sup>

**XCS30 and XCS30XL Device Pinouts (Continued)**

<b>XCS30/XL Pad Name</b>	<b>VQ100<sup>(5)</sup></b>	<b>TQ144</b>	<b>PQ208</b>	<b>PQ240</b>	<b>BG256<sup>(5)</sup></b>	<b>CS280<sup>(2,5)</sup></b>	<b>Bndry Scan</b>
I/O	-	-	P124	P144	M20	L19	493 <sup>(3)</sup>
I/O	-	-	P125	P145	L19	L18	496 <sup>(3)</sup>
I/O	P59	P86	P126	P146	L18	L17	499 <sup>(3)</sup>
I/O	P60	P87	P127	P147	L20	L16	502 <sup>(3)</sup>
I/O (D4 <sup>(2)</sup> )	P61	P88	P128	P148	K20	K19	505 <sup>(3)</sup>
I/O	P62	P89	P129	P149	K19	K18	508 <sup>(3)</sup>
VCC	P63	P90	P130	P150	VCC <sup>(4)</sup>	K17	-
GND	P64	P91	P131	P151	GND <sup>(4)</sup>	GND <sup>(4)</sup>	-
I/O (D3 <sup>(2)</sup> )	P65	P92	P132	P152	K18	K16	511 <sup>(3)</sup>
I/O	P66	P93	P133	P153	K17	K15	514 <sup>(3)</sup>
I/O	P67	P94	P134	P154	J20	J19	517 <sup>(3)</sup>
I/O	-	P95	P135	P155	J19	J18	520 <sup>(3)</sup>
I/O	-	-	P136	P156	J18	J17	523 <sup>(3)</sup>
I/O	-	-	P137	P157	J17	J16	526 <sup>(3)</sup>
I/O (D2 <sup>(2)</sup> )	P68	P96	P138	P159	H19	H17	529 <sup>(3)</sup>
I/O	P69	P97	P139	P160	H18	H16	532 <sup>(3)</sup>
VCC	-	-	P140	P161	VCC <sup>(4)</sup>	G19	-
I/O	-	P98	P141	P162	G19	G18	535 <sup>(3)</sup>
I/O	-	P99	P142	P163	F20	G17	538 <sup>(3)</sup>
I/O	-	-	-	P164	G18	G16	541 <sup>(3)</sup>
I/O	-	-	-	P165	F19	F19	544 <sup>(3)</sup>
GND	-	P100	P143	P166	GND <sup>(4)</sup>	GND <sup>(4)</sup>	-
I/O	-	-	-	P167	F18	F18	547 <sup>(3)</sup>
I/O	-	-	P144	P168	E19	F17	550 <sup>(3)</sup>
I/O	-	-	P145	P169	D20	F16	553 <sup>(3)</sup>
I/O	-	-	P146	P170	E18	F15	556 <sup>(3)</sup>
I/O	-	-	P147	P171	D19	E19	559 <sup>(3)</sup>
I/O	-	-	P148	P172	C20	E17	562 <sup>(3)</sup>
I/O (D1 <sup>(2)</sup> )	P70	P101	P149	P173	E17	E16	565 <sup>(3)</sup>
I/O	P71	P102	P150	P174	D18	D19	568 <sup>(3)</sup>
I/O	-	P103	P151	P175	C19	C19	571 <sup>(3)</sup>
I/O	-	P104	P152	P176	B20	B19	574 <sup>(3)</sup>
I/O (D0 <sup>(2)</sup> , DIN)	P72	P105	P153	P177	C18	C18	577 <sup>(3)</sup>
I/O, SGCK4 <sup>(1)</sup> , GCK6 <sup>(2)</sup> (DOUT)	P73	P106	P154	P178	B19	B18	580 <sup>(3)</sup>
CCLK	P74	P107	P155	P179	A20	A19	-
VCC	P75	P108	P156	P180	VCC <sup>(4)</sup>	C17	-
O, TDO	P76	P109	P157	P181	A19	B17	0
GND	P77	P110	P158	P182	GND <sup>(4)</sup>	GND <sup>(4)</sup>	-
I/O	P78	P111	P159	P183	B18	A18	2
I/O, PGCK4 <sup>(1)</sup> , GCK7 <sup>(2)</sup>	P79	P112	P160	P184	B17	A17	5
I/O	-	P113	P161	P185	C17	D16	8
I/O	-	P114	P162	P186	D16	C16	11
I/O (CS1 <sup>(2)</sup> )	P80	P115	P163	P187	A18	B16	14
I/O	P81	P116	P164	P188	A17	A16	17
I/O	-	-	P165	P189	C16	D15	20

**XCS30 and XCS30XL Device Pinouts (Continued)**

XCS30/XL Pad Name	VQ100 <sup>(5)</sup>	TQ144	PQ208	PQ240	BG256 <sup>(5)</sup>	CS280 <sup>(2,5)</sup>	Bndry Scan
I/O	-	-	-	P190	B16	A15	23
I/O	-	P117	P166	P191	A16	E14	26
I/O	-	-	P167	P192	C15	C14	29
I/O	-	-	P168	P193	B15	B14	32
I/O	-	-	P169	P194	A15	D14	35
GND	-	P118	P170	P196	GND <sup>(4)</sup>	GND <sup>(4)</sup>	-
I/O	-	P119	P171	P197	B14	A14	38
I/O	-	P120	P172	P198	A14	C13	41
I/O	-	-	-	P199	C13	B13	44
I/O	-	-	-	P200	B13	A13	47
VCC	-	-	P173	P201	VCC <sup>(4)</sup>	D13	-
I/O	P82	P121	P174	P202	C12	B12	50
I/O	P83	P122	P175	P203	B12	D12	53
I/O	-	-	P176	P205	A12	A11	56
I/O	-	-	P177	P206	B11	B11	59
I/O	P84	P123	P178	P207	C11	C11	62
I/O	P85	P124	P179	P208	A11	D11	65
I/O	P86	P125	P180	P209	A10	A10	68
I/O	P87	P126	P181	P210	B10	B10	71
GND	P88	P127	P182	P211	GND <sup>(4)</sup>	GND <sup>(4)</sup>	-

2/8/00

**Notes:**

1. 5V Spartan family only
2. 3V Spartan-XL family only
3. The "PWRDWN" on the XCS30XL is not part of the Boundary Scan chain. For the XCS30XL, subtract 1 from all Boundary Scan numbers from GCK3 on (295 and higher).
4. Pads labeled GND<sup>(4)</sup> or V<sub>CC</sub><sup>(4)</sup> are internally bonded to Ground or V<sub>CC</sub> planes within the package.
5. CS280 package, and VQ100 and BG256 packages for XCS30 only, discontinued by [PDN2004-01](#)

**Additional XCS30/XL Package Pins**

**PQ240**

GND Pins					
P22	P37	P83	P98	P143	P158
P204	P219	-	-	-	-
Not Connected Pins					
P195	-	-	-	-	-

2/12/98

**BG256**

VCC Pins					
C14	D6	D7	D11	D14	D15
E20	F1	F4	F17	G4	G17
K4	L17	P4	P17	P19	R2
R4	R17	U6	U7	U10	U14
U15	V7	W20	-	-	-

GND Pins					
A1	B7	D4	D8	D13	D17
G20	H4	H17	N3	N4	N17
U4	U8	U13	U17	W14	-
Not Connected Pins					
A7	A13	C8	D12	H20	J3
J4	M4	M19	V9	W9	W13
Y13	-	-	-	-	-

6/4/97

**CS280**

VCC Pins					
A1	A7	C10	C17	D13	G1
G1	G19	K2	K17	M4	N16
T7	U3	U10	U17	W13	-
GND Pins					

CS280

VCC Pins					
E5	E7	E8	E9	E11	E12
E13	G5	G15	H5	H15	J5
J15	L5	L15	M5	M15	N5
N15	R7	R8	R9	R11	R12
R13	-	-	-	-	-
Not Connected Pins					
A4	A12	C8	C12	C15	D1
D2	D5	D8	D17	D18	E15
H2	H3	H18	H19	L4	M1
M16	M18	R2	R4	R5	R15
R17	T8	T15	U5	V8	V12
W12	W16	-	-	-	-
Not Connected Pins (VCC in XCS40XL)					
B5	B15	E3	E18	R3	R18
V5	V15	-	-	-	-

5/21/02

XCS40 and XCS40XL Device Pinouts

XCS40/XL Pad Name	PQ208	PQ240	BG256	CS280 <sup>(2,5)</sup>	Bndry Scan
VCC	P183	P212	VCC <sup>(4)</sup>	VCC <sup>(4)</sup>	-
I/O	P184	P213	C10	D10	86
I/O	P185	P214	D10	E10	89
I/O	P186	P215	A9	A9	92
I/O	P187	P216	B9	B9	95
I/O	P188	P217	C9	C9	98
I/O	P189	P218	D9	D9	101
I/O	P190	P220	A8	A8	104
I/O	P191	P221	B8	B8	107
I/O	-	-	C8	C8	110
I/O	-	-	A7	D8	113
VCC	P192	P222	VCC <sup>(4)</sup>	VCC <sup>(4)</sup>	-
I/O	-	P223	A6	B7	116
I/O	-	P224	C7	C7	119
I/O	P193	P225	B6	D7	122
I/O	P194	P226	A5	A6	125
GND	P195	P227	GND <sup>(4)</sup>	GND <sup>(4)</sup>	-
I/O	P196	P228	C6	B6	128
I/O	P197	P229	B5	C6	131
I/O	P198	P230	A4	D6	134
I/O	P199	P231	C5	E6	137

XCS40 and XCS40XL Device Pinouts

XCS40/XL Pad Name	PQ208	PQ240	BG256	CS280 <sup>(2,5)</sup>	Bndry Scan
I/O	P200	P232	B4	A5	140
I/O	P201	P233	A3	C5	143
I/O	-	-	-	D5	146
I/O	-	-	-	A4	149
I/O	P202	P234	D5	B4	152
I/O	P203	P235	C4	C4	155
I/O	P204	P236	B3	A3	158
I/O	P205	P237	B2	A2	161
I/O	P206	P238	A2	B3	164
I/O, SGCK1 <sup>(1)</sup> , GCK8 <sup>(2)</sup>	P207	P239	C3	B2	167
VCC	P208	P240	VCC <sup>(4)</sup>	VCC <sup>(4)</sup>	-
GND	P1	P1	GND <sup>(4)</sup>	GND <sup>(4)</sup>	-
I/O, PGCK1 <sup>(1)</sup> , GCK1 <sup>(2)</sup>	P2	P2	B1	C3	170
I/O	P3	P3	C2	C2	173
I/O	P4	P4	D2	B1	176
I/O	P5	P5	D3	C1	179
I/O, TDI	P6	P6	E4	D4	182
I/O, TCK	P7	P7	C1	D3	185
I/O	-	-	-	D2	188
I/O	-	-	-	D1	191
I/O	P8	P8	D1	E2	194
I/O	P9	P9	E3	E4	197
I/O	P10	P10	E2	E1	200
I/O	P11	P11	E1	F5	203
I/O	P12	P12	F3	F3	206
I/O	-	P13	F2	F2	209
GND	P13	P14	GND <sup>(4)</sup>	GND <sup>(4)</sup>	-
I/O	P14	P15	G3	F4	212
I/O	P15	P16	G2	F1	215
I/O, TMS	P16	P17	G1	G3	218
I/O	P17	P18	H3	G2	221
VCC	P18	P19	VCC <sup>(4)</sup>	VCC <sup>(4)</sup>	-
I/O	-	P20	H2	G4	224
I/O	-	P21	H1	H1	227
I/O	-	-	J4	H3	230
I/O	-	-	J3	H2	233
I/O	P19	P23	J2	H4	236
I/O	P20	P24	J1	J1	239
I/O	P21	P25	K2	J2	242
I/O	P22	P26	K3	J3	245
I/O	P23	P27	K1	J4	248
I/O	P24	P28	L1	K1	251

**XCS40 and XCS40XL Device Pinouts**

XCS40/XL Pad Name	PQ208	PQ240	BG256	CS280 <sup>(2,5)</sup>	Bndry Scan
GND	P25	P29	GND <sup>(4)</sup>	GND <sup>(4)</sup>	-
VCC	P26	P30	VCC <sup>(4)</sup>	VCC <sup>(4)</sup>	-
I/O	P27	P31	L2	K3	254
I/O	P28	P32	L3	K4	257
I/O	P29	P33	L4	K5	260
I/O	P30	P34	M1	L1	263
I/O	P31	P35	M2	L2	266
I/O	P32	P36	M3	L3	269
I/O	-	-	M4	L4	272
I/O	-	-	-	M1	275
I/O	-	P38	N1	M2	278
I/O	-	P39	N2	M3	281
VCC	P33	P40	VCC <sup>(4)</sup>	VCC <sup>(4)</sup>	-
I/O	P34	P41	P1	N1	284
I/O	P35	P42	P2	N2	287
I/O	P36	P43	R1	N3	290
I/O	P37	P44	P3	N4	293
GND	P38	P45	GND <sup>(4)</sup>	GND <sup>(4)</sup>	-
I/O	-	P46	T1	P1	296
I/O	P39	P47	R3	P2	299
I/O	P40	P48	T2	P3	302
I/O	P41	P49	U1	P4	305
I/O	P42	P50	T3	P5	308
I/O	P43	P51	U2	R1	311
I/O	-	-	-	R2	314
I/O	-	-	-	R4	317
I/O	P44	P52	V1	T1	320
I/O	P45	P53	T4	T2	323
I/O	P46	P54	U3	T3	326
I/O	P47	P55	V2	U1	329
I/O	P48	P56	W1	V1	332
I/O, SGCK2 <sup>(1)</sup> , GCK2 <sup>(2)</sup>	P49	P57	V3	U2	335
Not Connected <sup>(1)</sup> M1 <sup>(2)</sup>	P50	P58	W2	V2	338
GND	P51	P59	GND <sup>(4)</sup>	GND <sup>(4)</sup>	-
MODE <sup>(1)</sup> , M0 <sup>(2)</sup>	P52	P60	Y1	W1	341
VCC	P53	P61	VCC <sup>(4)</sup>	VCC <sup>(4)</sup>	-
Not Connected <sup>(1)</sup> PWRDWN <sup>(2)</sup>	P54	P62	W3	V3	342 <sup>(1)</sup>
I/O, PGCK2 <sup>(1)</sup> , GCK3 <sup>(2)</sup>	P55	P63	Y2	W2	343 <sup>(3)</sup>

**XCS40 and XCS40XL Device Pinouts**

XCS40/XL Pad Name	PQ208	PQ240	BG256	CS280 <sup>(2,5)</sup>	Bndry Scan
I/O (HDC)	P56	P64	W4	W3	346 <sup>(3)</sup>
I/O	P57	P65	V4	T4	349 <sup>(3)</sup>
I/O	P58	P66	U5	U4	352 <sup>(3)</sup>
I/O	P59	P67	Y3	V4	355 <sup>(3)</sup>
I/O (LDC)	P60	P68	Y4	W4	358 <sup>(3)</sup>
I/O	-	-	-	R5	361 <sup>(3)</sup>
I/O	-	-	-	U5	364 <sup>(3)</sup>
I/O	P61	P69	V5	T5	367 <sup>(3)</sup>
I/O	P62	P70	W5	W5	370 <sup>(3)</sup>
I/O	P63	P71	Y5	R6	373 <sup>(3)</sup>
I/O	P64	P72	V6	U6	376 <sup>(3)</sup>
I/O	P65	P73	W6	V6	379 <sup>(3)</sup>
I/O	-	P74	Y6	T6	382 <sup>(3)</sup>
GND	P66	P75	GND <sup>(4)</sup>	GND <sup>(4)</sup>	-
I/O	P67	P76	W7	W6	385 <sup>(3)</sup>
I/O	P68	P77	Y7	U7	388 <sup>(3)</sup>
I/O	P69	P78	V8	V7	391 <sup>(3)</sup>
I/O	P70	P79	W8	W7	394 <sup>(3)</sup>
VCC	P71	P80	VCC <sup>(4)</sup>	VCC <sup>(4)</sup>	-
I/O	P72	P81	Y8	W8	397 <sup>(3)</sup>
I/O	P73	P82	U9	U8	400 <sup>(3)</sup>
I/O	-	-	V9	V8	403 <sup>(3)</sup>
I/O	-	-	W9	T8	406 <sup>(3)</sup>
I/O	-	P84	Y9	W9	409 <sup>(3)</sup>
I/O	-	P85	W10	V9	412 <sup>(3)</sup>
I/O	P74	P86	V10	U9	415 <sup>(3)</sup>
I/O	P75	P87	Y10	T9	418 <sup>(3)</sup>
I/O	P76	P88	Y11	W10	421 <sup>(3)</sup>
I/O (INIT)	P77	P89	W11	V10	424 <sup>(3)</sup>
VCC	P78	P90	VCC <sup>(4)</sup>	VCC <sup>(4)</sup>	VCC <sup>(4)</sup>
GND	P79	P91	GND <sup>(4)</sup>	GND <sup>(4)</sup>	-
I/O	P80	P92	V11	T10	427 <sup>(3)</sup>
I/O	P81	P93	U11	R10	430 <sup>(3)</sup>
I/O	P82	P94	Y12	W11	433 <sup>(3)</sup>
I/O	P83	P95	W12	V11	436 <sup>(3)</sup>
I/O	P84	P96	V12	U11	439 <sup>(3)</sup>
I/O	P85	P97	U12	T11	442 <sup>(3)</sup>
I/O	-	-	Y13	W12	445 <sup>(3)</sup>
I/O	-	-	W13	V12	448 <sup>(3)</sup>
I/O	-	P99	V13	U12	451 <sup>(3)</sup>
I/O	-	P100	Y14	T12	454 <sup>(3)</sup>
VCC	P86	P101	VCC <sup>(4)</sup>	VCC <sup>(4)</sup>	-
I/O	P87	P102	Y15	V13	457 <sup>(3)</sup>
I/O	P88	P103	V14	U13	460 <sup>(3)</sup>
I/O	P89	P104	W15	T13	463 <sup>(3)</sup>

## XCS40 and XCS40XL Device Pinouts

XCS40/XL Pad Name	PQ208	PQ240	BG256	CS280 <sup>(2,5)</sup>	Bndry Scan
I/O	P90	P105	Y16	W14	466 <sup>(3)</sup>
GND	P91	P106	GND <sup>(4)</sup>	GND <sup>(4)</sup>	-
I/O	-	P107	V15	V14	469 <sup>(3)</sup>
I/O	P92	P108	W16	U14	472 <sup>(3)</sup>
I/O	P93	P109	Y17	T14	475 <sup>(3)</sup>
I/O	P94	P110	V16	R14	478 <sup>(3)</sup>
I/O	P95	P111	W17	W15	481 <sup>(3)</sup>
I/O	P96	P112	Y18	U15	484 <sup>(3)</sup>
I/O	-	-	-	T15	487 <sup>(3)</sup>
I/O	-	-	-	W16	490 <sup>(3)</sup>
I/O	P97	P113	U16	V16	493 <sup>(3)</sup>
I/O	P98	P114	V17	U16	496 <sup>(3)</sup>
I/O	P99	P115	W18	W17	499 <sup>(3)</sup>
I/O	P100	P116	Y19	W18	502 <sup>(3)</sup>
I/O	P101	P117	V18	V17	505 <sup>(3)</sup>
I/O, SGCK3 <sup>(1)</sup> , GCK4 <sup>(2)</sup>	P102	P118	W19	V18	508 <sup>(3)</sup>
GND	P103	P119	GND <sup>(4)</sup>	GND <sup>(4)</sup>	-
DONE	P104	P120	Y20	W19	-
VCC	P105	P121	VCC <sup>(4)</sup>	VCC <sup>(4)</sup>	-
PROGRAM	P106	P122	V19	U18	-
I/O (D7 <sup>(2)</sup> )	P107	P123	U19	V19	511 <sup>(3)</sup>
I/O, PGCK3 <sup>(1)</sup> , GCK5 <sup>(2)</sup>	P108	P124	U18	U19	514 <sup>(3)</sup>
I/O	P109	P125	T17	T16	517 <sup>(3)</sup>
I/O	P110	P126	V20	T17	520 <sup>(3)</sup>
I/O	-	P127	U20	T18	523 <sup>(3)</sup>
I/O	P111	P128	T18	T19	526 <sup>(3)</sup>
I/O	-	-	-	R15	529 <sup>(3)</sup>
I/O	-	-	-	R17	523 <sup>(3)</sup>
I/O (D6 <sup>(2)</sup> )	P112	P129	T19	R16	535 <sup>(3)</sup>
I/O	P113	P130	T20	R19	538 <sup>(3)</sup>
I/O	P114	P131	R18	P15	541 <sup>(3)</sup>
I/O	P115	P132	R19	P17	544 <sup>(3)</sup>
I/O	P116	P133	R20	P18	547 <sup>(3)</sup>
I/O	P117	P134	P18	P16	550 <sup>(3)</sup>
GND	P118	P135	GND <sup>(4)</sup>	GND <sup>(4)</sup>	-
I/O	-	P136	P20	P19	553 <sup>(3)</sup>
I/O	-	P137	N18	N17	556 <sup>(3)</sup>
I/O	P119	P138	N19	N18	559 <sup>(3)</sup>
I/O	P120	P139	N20	N19	562 <sup>(3)</sup>
VCC	P121	P140	VCC <sup>(4)</sup>	VCC <sup>(4)</sup>	-
I/O (D5 <sup>(2)</sup> )	P122	P141	M17	M19	565 <sup>(3)</sup>
I/O	P123	P142	M18	M17	568 <sup>(3)</sup>

## XCS40 and XCS40XL Device Pinouts

XCS40/XL Pad Name	PQ208	PQ240	BG256	CS280 <sup>(2,5)</sup>	Bndry Scan
I/O	-	-	-	M18	571 <sup>(3)</sup>
I/O	-	-	M19	M16	574 <sup>(3)</sup>
I/O	P124	P144	M20	L19	577 <sup>(3)</sup>
I/O	P125	P145	L19	L18	580 <sup>(3)</sup>
I/O	P126	P146	L18	L17	583 <sup>(3)</sup>
I/O	P127	P147	L20	L16	586 <sup>(3)</sup>
I/O (D4 <sup>(2)</sup> )	P128	P148	K20	K19	589 <sup>(3)</sup>
I/O	P129	P149	K19	K18	592 <sup>(3)</sup>
VCC	P130	P150	VCC <sup>(4)</sup>	VCC <sup>(4)</sup>	-
GND	P131	P151	GND <sup>(4)</sup>	GND <sup>(4)</sup>	-
I/O (D3 <sup>(2)</sup> )	P132	P152	K18	K16	595 <sup>(3)</sup>
I/O	P133	P153	K17	K15	598 <sup>(3)</sup>
I/O	P134	P154	J20	J19	601 <sup>(3)</sup>
I/O	P135	P155	J19	J18	604 <sup>(3)</sup>
I/O	P136	P156	J18	J17	607 <sup>(3)</sup>
I/O	P137	P157	J17	J16	610 <sup>(3)</sup>
I/O	-	-	H20	H19	613 <sup>(3)</sup>
I/O	-	-	-	H18	616 <sup>(3)</sup>
I/O (D2 <sup>(2)</sup> )	P138	P159	H19	H17	619 <sup>(3)</sup>
I/O	P139	P160	H18	H16	622 <sup>(3)</sup>
VCC	P140	P161	VCC <sup>(4)</sup>	VCC <sup>(4)</sup>	-
I/O	P141	P162	G19	G18	625 <sup>(3)</sup>
I/O	P142	P163	F20	G17	628 <sup>(3)</sup>
I/O	-	P164	G18	G16	631 <sup>(3)</sup>
I/O	-	P165	F19	F19	634 <sup>(3)</sup>
GND	P143	P166	GND <sup>(4)</sup>	GND <sup>(4)</sup>	-
I/O	-	P167	F18	F18	637 <sup>(3)</sup>
I/O	P144	P168	E19	F17	640 <sup>(3)</sup>
I/O	P145	P169	D20	F16	643 <sup>(3)</sup>
I/O	P146	P170	E18	F15	646 <sup>(3)</sup>
I/O	P147	P171	D19	E19	649 <sup>(3)</sup>
I/O	P148	P172	C20	E17	652 <sup>(3)</sup>
I/O (D1 <sup>(2)</sup> )	P149	P173	E17	E16	655 <sup>(3)</sup>
I/O	P150	P174	D18	D19	658 <sup>(3)</sup>
I/O	-	-	-	D18	661 <sup>(3)</sup>
I/O	-	-	-	D17	664 <sup>(3)</sup>
I/O	P151	P175	C19	C19	667 <sup>(3)</sup>
I/O	P152	P176	B20	B19	670 <sup>(3)</sup>
I/O (D0 <sup>(2)</sup> , DIN)	P153	P177	C18	C18	673 <sup>(3)</sup>
I/O, SGCK4 <sup>(1)</sup> , GCK6 <sup>(2)</sup> (DOUT)	P154	P178	B19	B18	676 <sup>(3)</sup>
CCLK	P155	P179	A20	A19	-
VCC	P156	P180	VCC <sup>(4)</sup>	VCC <sup>(4)</sup>	-

### XCS40 and XCS40XL Device Pinouts

XCS40/XL Pad Name	PQ208	PQ240	BG256	CS280 <sup>(2,5)</sup>	Bndry Scan
O, TDO	P157	P181	A19	B17	0
GND	P158	P182	GND <sup>(4)</sup>	GND <sup>(4)</sup>	-
I/O	P159	P183	B18	A18	2
I/O, PGCK4 <sup>(1)</sup> , GCK7 <sup>(2)</sup>	P160	P184	B17	A17	5
I/O	P161	P185	C17	D16	8
I/O	P162	P186	D16	C16	11
I/O (CS1 <sup>(2)</sup> )	P163	P187	A18	B16	14
I/O	P164	P188	A17	A16	17
I/O	-	-	-	E15	20
I/O	-	-	-	C15	23
I/O	P165	P189	C16	D15	26
I/O	-	P190	B16	A15	29
I/O	P166	P191	A16	E14	32
I/O	P167	P192	C15	C14	35
I/O	P168	P193	B15	B14	38
I/O	P169	P194	A15	D14	41
GND	P170	P196	GND <sup>(4)</sup>	GND <sup>(4)</sup>	-
I/O	P171	P197	B14	A14	44
I/O	P172	P198	A14	C13	47
I/O	-	P199	C13	B13	50
I/O	-	P200	B13	A13	53
VCC	P173	P201	VCC <sup>(4)</sup>	VCC <sup>(4)</sup>	-
I/O	-	-	A13	A12	56
I/O	-	-	D12	C12	59
I/O	P174	P202	C12	B12	62
I/O	P175	P203	B12	D12	65
I/O	P176	P205	A12	A11	68
I/O	P177	P206	B11	B11	71
I/O	P178	P207	C11	C11	74
I/O	P179	P208	A11	D11	77
I/O	P180	P209	A10	A10	80
I/O	P181	P210	B10	B10	83
GND	P182	P211	GND <sup>(4)</sup>	GND <sup>(4)</sup>	-

2/8/00

**Notes:**

1. 5V Spartan family only
2. 3V Spartan-XL family only
3. The "PWRDWN" on the XCS40XL is not part of the Boundary Scan chain. For the XCS40XL, subtract 1 from all Boundary Scan numbers from GCK3 on (343 and higher).
4. Pads labeled GND<sup>(4)</sup> or VCC<sup>(4)</sup> are internally bonded to Ground or VCC planes within the package.
5. CS280 package discontinued by [PDN2004-01](#)

### Additional XCS40/XL Package Pins

**PQ240**

GND Pins					
P22	P37	P83	P98	P143	P158
P204	P219	-	-	-	-
Not Connected Pins					
P195	-	-	-	-	-

2/12/98

**BG256**

VCC Pins					
C14	D6	D7	D11	D14	D15
E20	F1	F4	F17	G4	G17
K4	L17	P4	P17	P19	R2
R4	R17	U6	U7	U10	U14
U15	V7	W20	-	-	-
GND Pins					
A1	B7	D4	D8	D13	D17
G20	H4	H17	N3	N4	N17
U4	U8	U13	U17	W14	-

6/17/97

**CS280**

VCC Pins					
A1	A7	B5	B15	C10	C17
D13	E3	E18	G1	G19	K2
K17	M4	N16	R3	R18	T7
U3	U10	U17	V5	V15	W13
GND Pins					
E5	E7	E8	E9	E11	E12
E13	G5	G15	H5	H15	J5
J15	L5	L15	M5	M15	N5
N15	R7	R8	R9	R11	R12
R13	-	-	-	-	-

5/19/99

## Product Availability

Table 19 shows the packages and speed grades for Spartan/XL devices. Table 20 shows the number of user I/Os available for each device/package combination.

Table 19: Component Availability Chart for Spartan/XL FPGAs

Device	Pins	84	100	144	144	208	240	256	280
	Type	Plastic PLCC	Plastic VQFP	Chip Scale	Plastic TQFP	Plastic PQFP	Plastic PQFP	Plastic BGA	Chip Scale
	Code	PC84 <sup>(3)</sup>	VQ100 <sup>(3)</sup>	CS144 <sup>(3)</sup>	TQ144	PQ208	PQ240	BG256 <sup>(3)</sup>	CS280 <sup>(3)</sup>
XCS05	-3	C <sup>(3)</sup>	C, I	-	-	-	-	-	-
	-4	C <sup>(3)</sup>	C	-	-	-	-	-	-
XCS10	-3	C <sup>(3)</sup>	C, I	-	C	-	-	-	-
	-4	C <sup>(3)</sup>	C	-	C	-	-	-	-
XCS20	-3	-	C	-	C, I	C, I	-	-	-
	-4	-	C	-	C	C	-	-	-
XCS30	-3	-	C <sup>(3)</sup>	-	C, I	C, I	C	C <sup>(3)</sup>	-
	-4	-	C <sup>(3)</sup>	-	C	C	C	C <sup>(3)</sup>	-
XCS40	-3	-	-	-	-	C, I	C	C	-
	-4	-	-	-	-	C	C	C	-
XCS05XL	-4	C <sup>(3)</sup>	C, I	-	-	-	-	-	-
	-5	C <sup>(3)</sup>	C	-	-	-	-	-	-
XCS10XL	-4	C <sup>(3)</sup>	C, I	C <sup>(3)</sup>	C	-	-	-	-
	-5	C <sup>(3)</sup>	C	C <sup>(3)</sup>	C	-	-	-	-
XCS20XL	-4	-	C, I	C <sup>(3)</sup>	C, I	C, I	-	-	-
	-5	-	C	C <sup>(3)</sup>	C	C	-	-	-
XCS30XL	-4	-	C, I	-	C, I	C, I	C	C	C <sup>(3)</sup>
	-5	-	C	-	C	C	C	C	C <sup>(3)</sup>
XCS40XL	-4	-	-	-	-	C, I	C	C, I	C <sup>(3)</sup>
	-5	-	-	-	-	C	C	C	C <sup>(3)</sup>

6/25/08

### Notes:

1. C = Commercial  $T_J = 0^\circ$  to  $+85^\circ\text{C}$
2. I = Industrial  $T_J = -40^\circ\text{C}$  to  $+100^\circ\text{C}$
3. PC84, CS144, and CS280 packages, and VQ100 and BG256 packages for XCS30 only, discontinued by [PDN2004-01](#)
4. Some Spartan-XL devices are available in Pb-free package options. The Pb-free packages insert a "G" in the package code. Contact Xilinx for availability.

### Package Specifications

Package drawings and material declaration data sheets for the Spartan/XL devices can be found on the Xilinx website at:

[www.xilinx.com/support/documentation/spartan-xl.htm#19687](http://www.xilinx.com/support/documentation/spartan-xl.htm#19687)

Thermal data for the Spartan/XL packages can be found using the thermal query tool on the Xilinx website at:

[www.xilinx.com/cgi-bin/thermal/thermal.pl](http://www.xilinx.com/cgi-bin/thermal/thermal.pl)

Table 20: User I/O Chart for Spartan/XL FPGAs

Device	Max I/O	Package Type							
		PC84 <sup>(1)</sup>	VQ100 <sup>(1)</sup>	CS144 <sup>(1)</sup>	TQ144	PQ208	PQ240	BG256 <sup>(1)</sup>	CS280 <sup>(1)</sup>
XCS05	80	61 <sup>(1)</sup>	77	-	-	-	-	-	-
XCS10	112	61 <sup>(1)</sup>	77	-	112	-	-	-	-
XCS20	160	-	77	-	113	160	-	-	-
XCS30	192	-	77 <sup>(1)</sup>	-	113	169	192	192 <sup>(1)</sup>	-
XCS40	224	-	-	-	-	169	192	205	-
XCS05XL	80	61 <sup>(1)</sup>	77 <sup>(2)</sup>	-	-	-	-	-	-
XCS10XL	112	61 <sup>(1)</sup>	77 <sup>(2)</sup>	112 <sup>(1)</sup>	112 <sup>(2)</sup>	-	-	-	-
XCS20XL	160	-	77 <sup>(2)</sup>	113 <sup>(1)</sup>	113 <sup>(2)</sup>	160 <sup>(2)</sup>	-	-	-
XCS30XL	192	-	77 <sup>(2)</sup>	-	113 <sup>(2)</sup>	169 <sup>(2)</sup>	192 <sup>(2)</sup>	192 <sup>(2)</sup>	192 <sup>(1)</sup>
XCS40XL	224	-	-	-	-	169 <sup>(2)</sup>	192 <sup>(2)</sup>	205 <sup>(2)</sup>	224 <sup>(1)</sup>

6/25/08

**Notes:**

1. PC84, CS144, and CS280 packages, and VQ100 and BG256 packages for XCS30 only, discontinued by [PDN2004-01](#)
2. These Spartan-XL devices are available in Pb-free package options. The Pb-free packages insert a "G" in the package code. Contact Xilinx for availability.

## Ordering Information

**Example: XCS20XL-4 PQ208C**

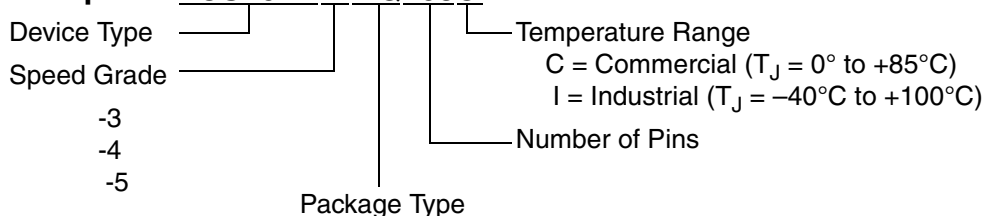

- |  |  |
|--|--|
| BG = Ball Grid Array                   | VQ = Very Thin Quad Flat Pack            |
| BGG = Ball Grid Array (Pb-free)        | VQG = Very Thin Quad Flat Pack (Pb-free) |
| PC = Plastic Lead Chip Carrier         | TQ = Thin Quad Flat Pack                 |
| PQ = Plastic Quad Flat Pack            | TQG = Thin Quad Flat Pack (Pb-free)      |
| PQG = Plastic Quad Flat Pack (Pb-free) | CS = Chip Scale                          |

### Revision History

The following table shows the revision history for this document.

Date	Version	Description
11/20/98	1.3	Added Spartan-XL specs and Power Down.
01/06/99	1.4	All Spartan-XL -4 specs designated Preliminary with no changes.
03/02/00	1.5	Added CS package, updated Spartan-XL specs to Final.
09/19/01	1.6	Reformatted, updated power specs, clarified configuration information. Removed $T_{SOL}$ soldering information from Absolute Maximum Ratings table. Changed <b>Figure 26</b> : Slave Serial Mode Characteristics: $T_{CCH}$ , $T_{CCL}$ from 45 to 40 ns. Changed Master Mode Configuration Switching Characteristics: $T_{CCLK}$ min. from 80 to 100 ns. Added Total Dist. RAM Bits to <b>Table 1</b> ; added <b>Start-Up, page 36</b> characteristics.
06/27/02	1.7	Clarified Express Mode pseudo daisy chain. Added new Industrial options. Clarified XCS30XL CS280 $V_{CC}$ pinout.
06/26/08	1.8	Noted that PC84, CS144, and CS280 packages, and VQ100 and BG256 packages for XCS30 only, are discontinued by <a href="#">PDN2004-01</a> . Extended description of recommended maximum delay of reconfiguration in <b>Delaying Configuration After Power-Up, page 35</b> . Added reference to Pb-free package options and provided link to <b>Package Specifications, page 81</b> . Updated links.
03/01/13	2.0	The products listed in this data sheet are obsolete. See <a href="#">XCN10016</a> and <a href="#">XCN11010</a> for further information.

## Looking for pricing, stock, or lifecycle information?

Click below to explore more details on WIN SOURCE:

 [View XCS40-3PQ208C on WIN SOURCE](#)

 [Xilinx Inc. Information](#)

## Optimize Your Supply Chain with WIN SOURCE Solutions

-  Global Sourcing Solution
-  Obsolete Management
-  Cost Control Management
-  Shortage Management
-  Alternative Solution
-  Excess Inventory Management