



For most current data sheet and other product information, visit www.burr-brown.com

CCD SIGNAL PROCESSOR For Digital Cameras

FEATURES

- **CCD SIGNAL PROCESSING:**
Correlated Double Sampling (CDS)
Programmable Black Level Clamping
- **PROGRAMMABLE GAIN AMPLIFIER (PGA):**
-6 to +42dB Gain Ranging
- **10-BIT DIGITAL DATA OUTPUT:**
Up to 20MHz Conversion Rate
No Missing Codes
- **79dB SIGNAL-TO-NOISE RATIO**
- **ON-CHIP GENERAL-PURPOSE 8-BIT DIGITAL-TO-ANALOG CONVERTERS**
- **PORTABLE OPERATION:**
Low Voltage: 2.7V to 3.6V
Low Power: 97mW (typ) at 3.0V
Stand-By Mode: 6mW

DESCRIPTION

The VSP2210 is a complete mixed-signal processing IC for digital cameras, providing signal conditioning and analog-to-digital conversion for the output of a CCD array. The primary CCD channel provides Correlated Double Sampling (CDS) to extract video information from the pixels, -6dB to +42dB gain ranging with digital control for varying illumination conditions, and black level clamping for an accurate black reference. Input signal clamping and offset correction of the input CDS is also performed. The stable gain control is linear in dB. Additionally, the black level is quickly recovered after gain change. The two on-chip general-purpose 8-bit digital-to-analog converters allow you to obtain analog various control voltage, such as V_{SUB} control of CCD imager. The VSP2210Y is available in an LQFP-48 package and operates from a single +3V/+3.3V supply.

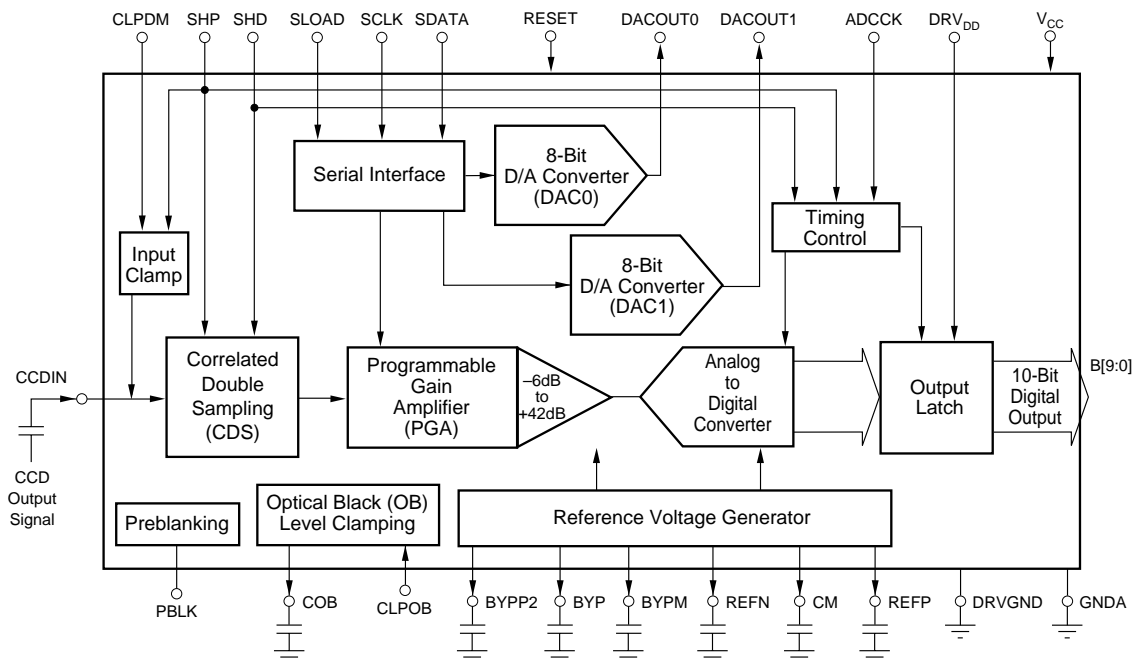

SPECIFICATIONS

At T_A = full specified temperature range, $V_{CC} = +3.0V$, $DRV_{DD} = +3.0V$, conversion rate (f_{ADDCk}) = 20MHz, unless otherwise specified.

PARAMETER	CONDITIONS	VSP2210Y			UNITS
		MIN	TYP	MAX	
RESOLUTION			10		Bits
MAXIMUM CONVERSION RATE		20			MHz
DIGITAL INPUT					
Logic Family			TTL		
Input Voltage	LOW to HIGH Threshold Voltage (VT+) HIGH to LOW Threshold Voltage (VT-)		1.7 1.0		V V
Input Current	Logic HIGH (I_{IH}), $V_{IN} = +3V$ Logic LOW (I_{IL}), $V_{IN} = 0V$			± 20 ± 20	μA μA
ADCCk Clock Duty Cycle			50		%
Input Capacitance			5		pF
Maximum Input Voltage		-0.3		5.3	V
DIGITAL OUTPUT					
Logic Family			CMOS		
Logic Coding			Straight Binary		
Output Voltage	Logic HIGH (V_{OH}), $I_{OH} = -2mA$ Logic LOW (V_{OL}), $I_{OL} = 2mA$	2.4		0.4	V V
ANALOG INPUT (CCDIN)					
Input Signal Level for Full-Scale Out	PGA Gain = 0dB	900			mV
Input Capacitance			15		pF
Input Limit		-0.3		3.3	V
TRANSFER CHARACTERISTICS					
Differential Non-Linearity (DNL)	PGA Gain = 0dB		± 0.5		LSB
Integral Non-Linearity (INL)	PGA Gain = 0dB		± 1		LSB
No Missing Codes			Guaranteed		
Step Response Settling Time	Full-Scale Step Input		1		Pixels
Overload Recovery Time	Step Input from 1.8V to 0V		2		Pixels
Data Latency			9 (fixed)		Clock Cycles
Signal-to-Noise Ratio ⁽¹⁾	Grounded Input Cap, PGA Gain = 0dB		79		dB
	Grounded Input Cap, Gain = +24dB		55		dB
CCD Offset Correction Range		-180		200	mV
CDS					
Reference Sample Settling Time	Within 1 LSB, Driver Impedance = 50 Ω			11	ns
Data Sample Settling Time	Within 1 LSB, Driver Impedance = 50 Ω			11	ns
INPUT CLAMP					
Clamp-On Resistance			400		Ω
Clamp Level			1.5		V
PROGRAMMABLE GAIN AMPLIFIER (PGA)					
Gain Control Resolution			10		Bits
Maximum Gain	Gain Code = 1111111111		42		dB
High Gain	Gain Code = 1101001000		34		dB
Medium Gain	Gain Code = 1000100000		20		dB
Low Gain	Gain Code = 0010000000		0		dB
Minimum Gain	Gain Code = 0000000000		-6		dB
Gain Control Error			± 0.5		dB
OPTICAL BLACK CLAMP LOOP					
Control DAC Resolution			10		Bits
Optical Black Clamp Level	Programmable Range of Clamp Level OBCLP Level at CODE = 1000	0	32	60	LSB LSB
Minimum Output Current for Control DAC	COB Pin		± 0.15		μA
Maximum Output Current for Control DAC	COB Pin		± 153		μA
Loop Time Constant	$C_{COB} = 0.1\mu F$		40.7		μs
Slew Rate	$C_{COB} = 0.1\mu F$, Output Current from Control DAC is Saturated		1530		V/s
GENERAL-PURPOSE 8-BIT DAC (DAC0, DAC1)					
Minimum Output Voltage	Input Code = 00000000		0.1		V
Maximum Output Voltage	Input Code = 11111111		2.9		V
Differential Non-Linearity (DNL)	At Input Code = 16 to 224		± 0.25		LSB
Integral Non-Linearity (INL)	At Input Code = 16 to 192		± 1		LSB
Offset Error			± 200		mV
Gain Error			± 5		%
Monotonicity			Guaranteed		

NOTE: (1) SNR = 20 log (full-scale voltage/rms noise).

SPECIFICATIONS (Cont.)

At T_A = full specified temperature range, $V_{CC} = +3.0V$, $DRV_{DD} = +3.0V$, conversion rate (f_{ADDCk}) = 20MHz, unless otherwise specified.

PARAMETER	CONDITIONS	VSP2210Y			UNITS
		MIN	TYP	MAX	
REFERENCE					
Positive Reference Voltage			1.75		V
Negative Reference Voltage			1.25		V
POWER SUPPLY					
Supply Voltage	V_{CC}, DRV_{DD}	2.7	3.0	3.6	V
Power Dissipation	No Load, DAC0 and DAC1 are Suspended		97		mW
Normal Operation Mode	$f_{ADDCk} = \text{NOT Apply}$		6		mW
Stand-By Mode					
TEMPERATURE RANGE					
Operating Temperature		-25		+85	°C
Storage Temperature		-55		+125	°C
Thermal Resistance, θ_{JA}	LQFP-48		100		°C/W

ABSOLUTE MAXIMUM RATINGS⁽¹⁾

Supply Voltage ⁽²⁾	+4.0V
Supply Voltage Differences ⁽³⁾	±0.1V
Ground Voltage Differences ⁽⁴⁾	±0.1V
Digital Input Voltage	-0.3V to 5.3V
Analog Input Voltage	-0.3V to $V_{CC} + 0.3V$
Input Current (any pins except supplies)	±10mA
Operating Temperature	-25°C to +85°C
Storage Temperature	-55°C to +125°C
Junction Temperature	+150°C
Lead Temperature (soldering, 5s)	+260°C
Package Temperature (IR reflow, peak, 10s)	+235°C

NOTES: (1) Stresses above those listed under Absolute Maximum Ratings may cause permanent damage to the device. Exposure to absolute maximum conditions for extended periods may affect device reliability. (2) V_{CC}, DRV_{DD} . (3) Among V_{CC} . (4) Among GNDA and DRVGND.



ELECTROSTATIC DISCHARGE SENSITIVITY

This integrated circuit can be damaged by ESD. Burr-Brown recommends that all integrated circuits be handled with appropriate precautions. Failure to observe proper handling and installation procedures can cause damage.

ESD damage can range from subtle performance degradation to complete device failure. Precision integrated circuits may be more susceptible to damage because very small parametric changes could cause the device not to meet its published specifications.

PACKAGE/ORDERING INFORMATION

PRODUCT	PACKAGE	PACKAGE DRAWING NUMBER	SPECIFIED TEMPERATURE RANGE	PACKAGE MARKING	ORDERING NUMBER ⁽¹⁾	TRANSPORT MEDIA
VSP2210Y "	LQFP-48 "	340 "	-25°C to +85°C "	VSP2210Y "	VSP2210Y VSP2210Y/2K	250-Piece Tray Tape and Reel

NOTE: (1) Models with a slash (/) are available only in Tape and Reel in the quantities indicated (e.g., /2K indicates 2000 devices per reel). Ordering 2000 pieces of "VSP2210Y/2K" will get a single 2000-piece Tape and Reel.

DEMO BOARD ORDERING INFORMATION

PRODUCT	ORDERING NUMBER
VSP2210Y	DEM-VSP2210Y

The information provided herein is believed to be reliable; however, BURR-BROWN assumes no responsibility for inaccuracies or omissions. BURR-BROWN assumes no responsibility for the use of this information, and all use of such information shall be entirely at the user's own risk. Prices and specifications are subject to change without notice. No patent rights or licenses to any of the circuits described herein are implied or granted to any third party. BURR-BROWN does not authorize or warrant any BURR-BROWN product for use in life support devices and/or systems.

PIN CONFIGURATION

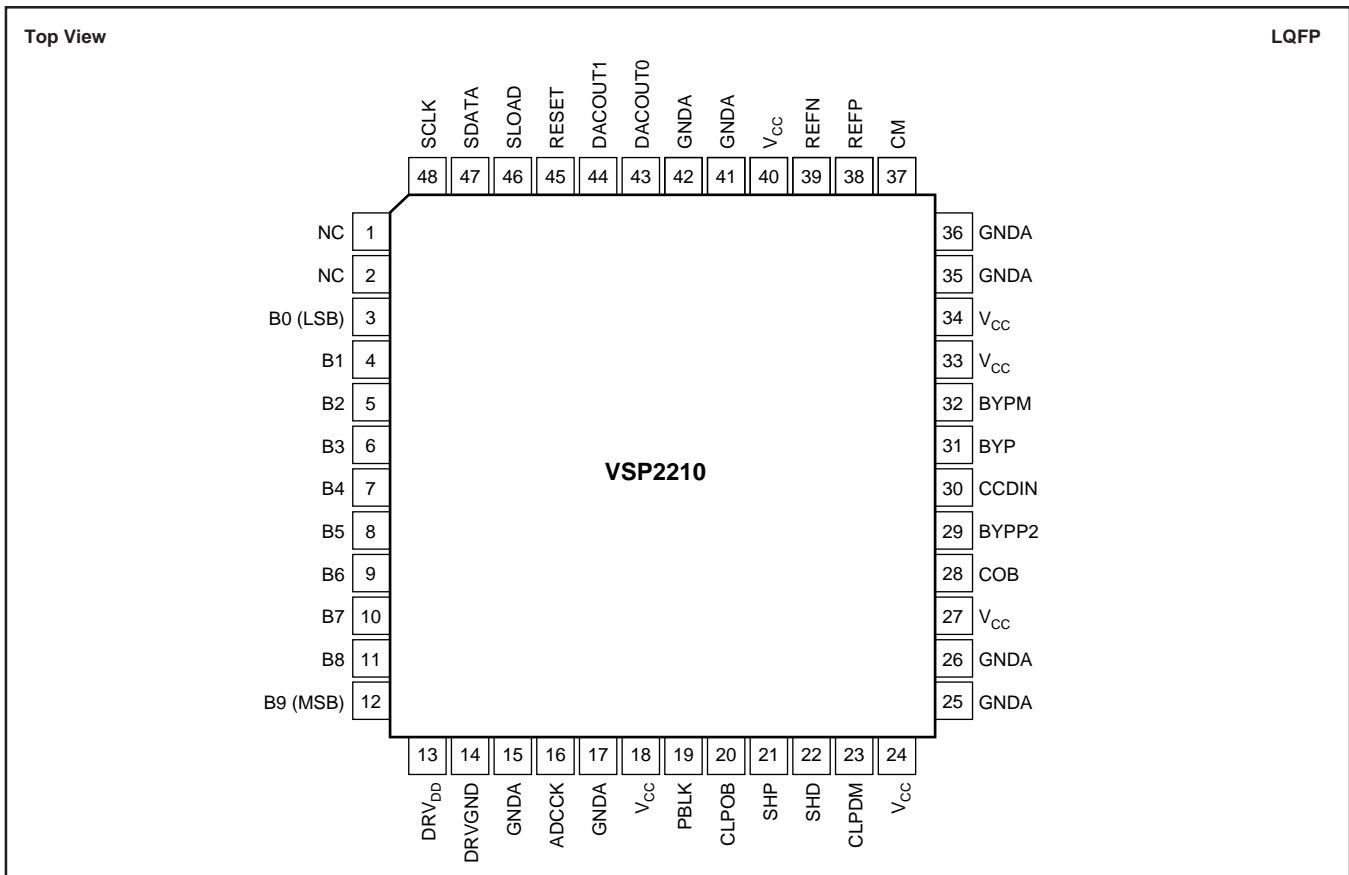

PIN DESCRIPTIONS

PIN	NAME	TYPE ⁽¹⁾	DESCRIPTION	PIN	NAME	TYPE ⁽¹⁾	DESCRIPTION
1	NC	—	No Connection	25	GNDA	P	Analog Ground
2	NC	—	No Connection	26	GNDA	P	Analog Ground
3	B0 (LSB)	DO	Bit 0, A/D Converter Output, Least Significant Bit	27	V _{CC}	P	Analog Power Supply
4	B1	DO	Bit 1, A/D Converter Output	28	COB	AO	Optical Black Clamp Loop Reference (Bypass to Ground ⁽³⁾)
5	B2	DO	Bit 2, A/D Converter Output	29	BYPP2	AO	Internal Reference P (Bypass to Ground ⁽⁴⁾)
6	B3	DO	Bit 3, A/D Converter Output	30	CCDIN	AI	CCD Signal Input
7	B4	DO	Bit 4, A/D Converter Output	31	BYP	AO	Internal Reference C (Bypass to Ground ⁽⁵⁾)
8	B5	DO	Bit 5, A/D Converter Output	32	BYPM	AO	Internal Reference N (Bypass to Ground ⁽⁴⁾)
9	B6	DO	Bit 6, A/D Converter Output	33	V _{CC}	P	Analog Power Supply
10	B7	DO	Bit 7, A/D Converter Output	34	V _{CC}	P	Analog Power Supply
11	B8	DO	Bit 8, A/D Converter Output	35	GNDA	P	Analog Ground
12	B9 (MSB)	DO	Bit 9, A/D Converter Output, Most Significant Bit	36	GNDA	P	Analog Ground
13	DRV _{DD}	P	Power Supply, Exclusively for Digital Output	37	CM	AO	A/D Converter Common-Mode Voltage (Bypass to Ground ⁽⁵⁾)
14	DRVGND	P	Digital Ground, Exclusively for Digital Output	38	REFP	AO	A/D Converter Positive Reference (Bypass to Ground ⁽⁵⁾)
15	GNDA	P	Analog Ground	39	REFN	AO	A/D Converter Negative Reference (Bypass to Ground ⁽⁵⁾)
16	ADCK	DI	Clock for Digital Output Buffer	40	V _{CC}	P	Analog Power Supply
17	GNDA	P	Analog Ground	41	GNDA	P	Analog Ground
18	V _{CC}	P	Analog Power Supply	42	GNDA	P	Analog Ground
19	PBLK	DI	Preblanking: HIGH = Normal Operation Mode LOW = Preblanking Mode: Digital Output "All Zero"	43	DACOUT0	AO	General-Purpose 8-Bit D/A Converter (DAC0) Output Voltage
20	CLPOB	DI	Optical Black Clamp Pulse (Default = Active LOW ⁽²⁾)	44	DACOUT1	AO	General-Purpose 8-Bit D/A Converter (DAC1) Output Voltage
21	SHP	DI	CDS Reference Level Sampling Pulse (Default = Active LOW ⁽²⁾)	45	RESET	DI	Asynchronous System Reset (Active LOW)
22	SHD	DI	CDS Data Level Sampling Pulse (Default = Active LOW ⁽²⁾)	46	SLOAD	DI	Serial Data Latch Signal (Triggered at the Rising Edge)
23	CLPDM	DI	Dummy Pixel Clamp Pulse (Default = Active LOW ⁽²⁾)	47	SDATA	DI	Serial Data Input
24	V _{CC}	P	Analog Power Supply	48	SCLK	DI	Clock for Serial Data Shift (Triggered at the Rising Edge)

NOTES: (1) Type designators: P = Power Supply and ground; DI = Digital Input; DO = Digital Output; AI = Analog Input; AO = Analog Output. (2) Refer to the "Serial Interface" section for more detail. (3) Should be connected to ground with a bypass capacitor. We recommend the value of 0.1µF to 0.22 µF, however, it depends on the application environment. Refer to the "Optical Black Level Clamp Loop" section for more detail. (4) Should be connected to ground with a bypass capacitor. We recommend the value of 1000pF, however, it depends on the application environment. Refer to the "Voltage Reference" section for more detail. (5) Should be connected to ground with a bypass capacitor (0.1µF). Refer to the "Voltage Reference" section for more detail.

CDS TIMING SPECIFICATIONS

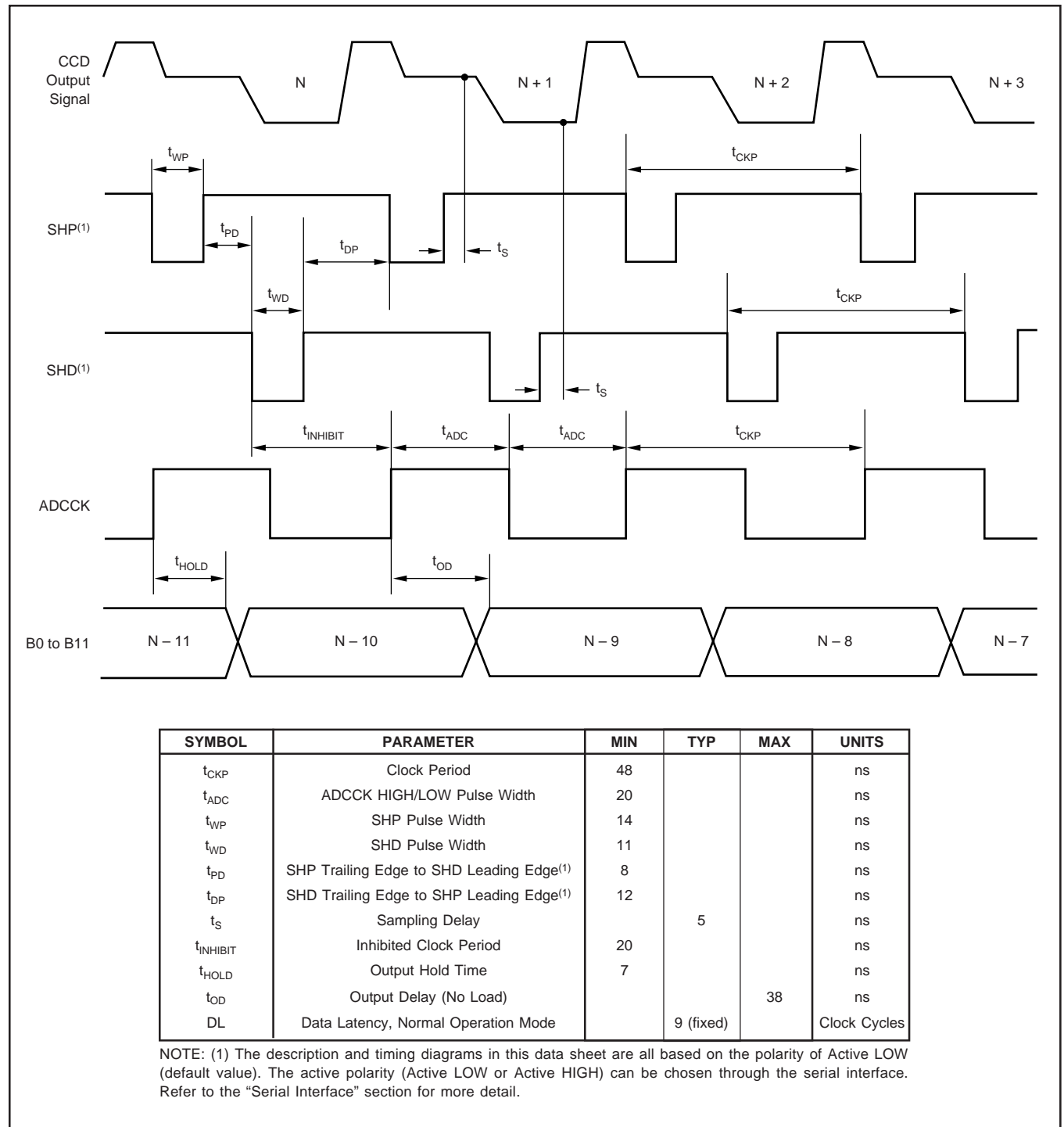

SYMBOL	PARAMETER	MIN	TYP	MAX	UNITS
t_{CKP}	Clock Period	48			ns
t_{ADC}	ADCCK HIGH/LOW Pulse Width	20			ns
t_{WP}	SHP Pulse Width	14			ns
t_{WD}	SHD Pulse Width	11			ns
t_{PD}	SHP Trailing Edge to SHD Leading Edge ⁽¹⁾	8			ns
t_{DP}	SHD Trailing Edge to SHP Leading Edge ⁽¹⁾	12			ns
t_S	Sampling Delay		5		ns
$t_{INHIBIT}$	Inhibited Clock Period	20			ns
t_{HOLD}	Output Hold Time	7			ns
t_{OD}	Output Delay (No Load)			38	ns
DL	Data Latency, Normal Operation Mode		9 (fixed)		Clock Cycles

NOTE: (1) The description and timing diagrams in this data sheet are all based on the polarity of Active LOW (default value). The active polarity (Active LOW or Active HIGH) can be chosen through the serial interface. Refer to the "Serial Interface" section for more detail.

SERIAL INTERFACE TIMING SPECIFICATIONS

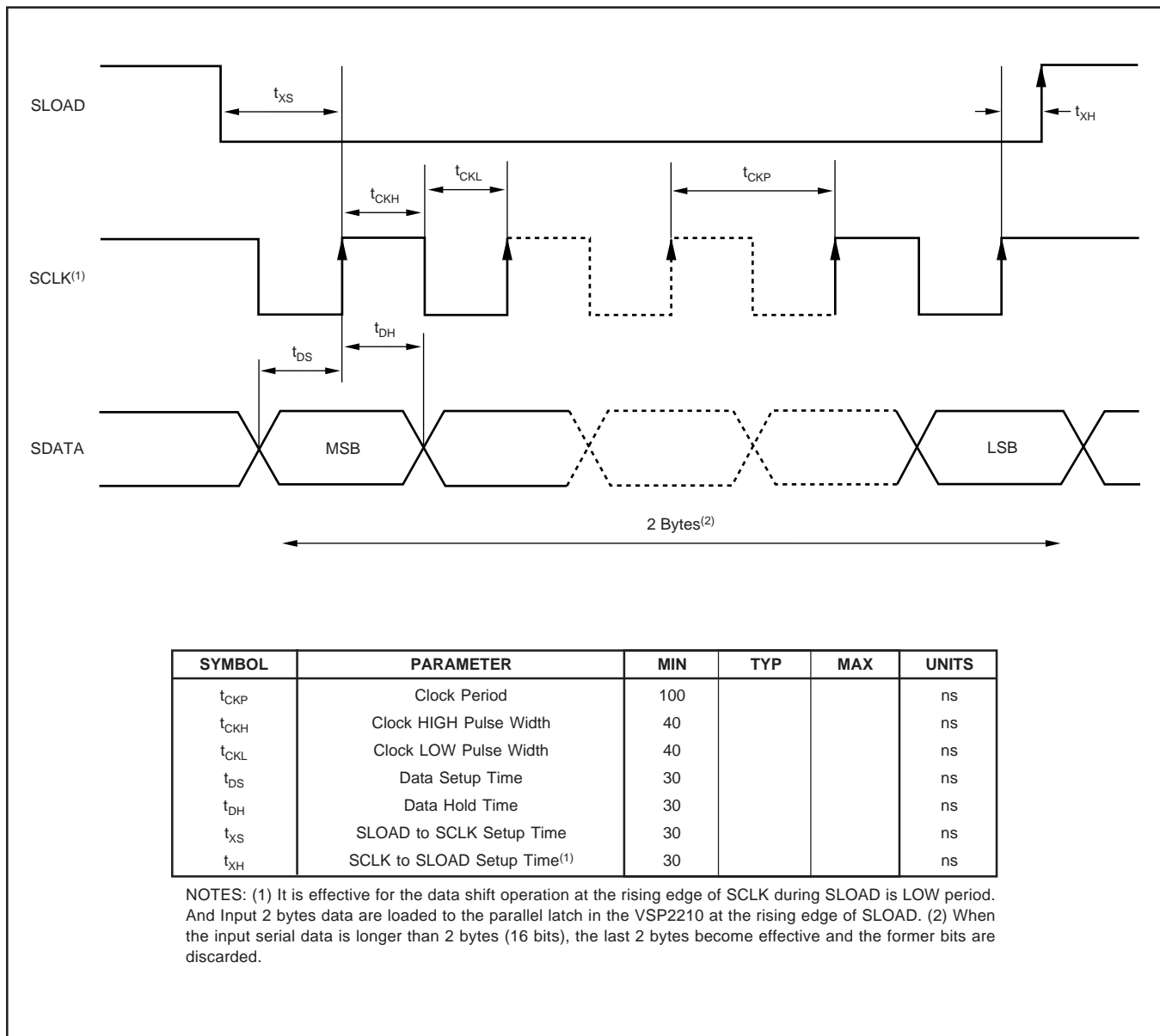

THEORY OF OPERATION

INTRODUCTION

The VSP2210 is a complete mixed-signal IC that contains all of the key features associated with the processing of the CCD imager output signal in a video camera, a digital still camera, security camera, or similar applications. A simplified block diagram is shown in the front page of this data sheet. The VSP2210 includes a correlated double sampler (CDS), programmable gain amplifier (PGA), Analog-to-Digital Converter (ADC), input clamp, optical black (OB) level clamp loop, serial interface, timing control, reference voltage generator, and general purpose 8-bit Digital-to-Analog Converters (DAC). We recommend an off-chip emitter follower buffer between the CCD output and the VSP2210 CCDIN input. The PGA gain control, clock polarity setting, and operation mode selection can be made through the serial interface. All parameters are reset to the default value when the RESET pin goes to LOW asynchronously from the clocks.

CORRELATED DOUBLE SAMPLER (CDS)

The output signal of a CCD imager is sampled twice during one pixel period: one at the reference interval and the other at the data interval. Subtracting these two samples extracts the video information of the pixel as well as removes any noise that is common, or correlated, to both the intervals. Therefore, the CDS is very important to reduce the reset noise and the low-frequency noises that are present on the CCD output signal. Figure 1 shows the simplified block diagram of the CDS and input clamp.

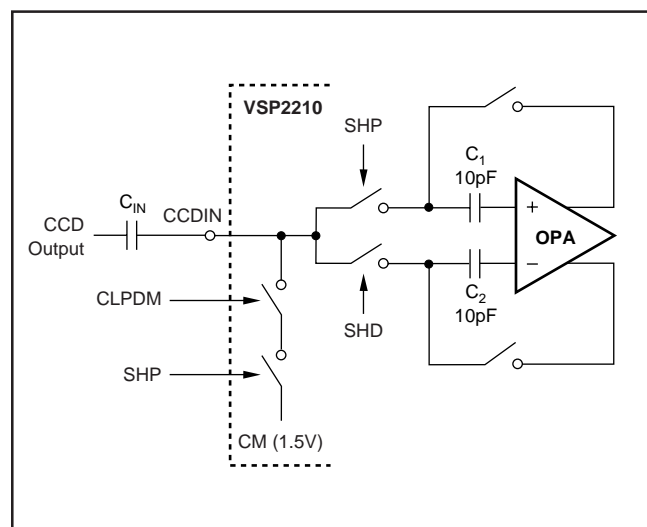

FIGURE 1. Simplified Block Diagram of CDS and Input Clamp.

The CDS is driven through an off-chip coupling capacitor (C_{IN}). AC coupling is strongly recommended because the DC level of the CCD output signal is usually several volts too high for the CDS to work properly.

A $0.1\mu\text{F}$ capacitor is recommended for C_{IN} , depending on the application environment. Additionally, we recommend an off-chip emitter follower buffer that can drive more than 10pF , because 10pF of the sampling capacitor and a few pF of stray capacitance can be seen at the input pin. The analog input signal range at the CCDIN pin is 1Vp-p , and the appropriate common mode voltage for the CDS is around 0.5V to 1.5V .

The reference level is sampled during SHP active period, and the voltage level is held on sampling capacitor C_1 at the trailing edge of SHP. The data level is sampled during SHD active period, and the voltage level is held on the sampling capacitor C_2 at the trailing edge of SHD. The switched-capacitor amplifier then performs the subtraction of these two levels.

The active polarity of SHP/SHD (Active HIGH or Active LOW) can be selected through the serial interface (refer to "Serial Interface" section for more detail). The default value of SHP/SHD is "Active LOW". However, immediately after power on, this value is "Unknown". For this reason, the appropriate value must be set by using the serial interface, or reset to the default value by the RESET pin. The description and the timing diagrams in this data sheet are all based on the polarity of Active LOW (default value).

INPUT CLAMP OR DUMMY PIXEL CLAMP

The buffered CCD output is capacitively coupled to the VSP2210. The purpose of the input clamp is to restore the DC component of the input signal that was lost with the AC coupling and establish the desired DC bias point for the CDS. Figure 1 also shows a simplified block diagram of the input clamp. The input level is clamped to internal reference voltage CM (1.5V) during the dummy pixel interval. More specifically, when both CLPDM and SHP are active, the dummy clamp function becomes active. If the dummy pixels and/or the CLPDM pulse is not available in your system, the CLPOB pulse can be used in place of CLPDM, as long as the clamping takes place during black pixels. In this case, both the CPLDM pin (actives as same timing as CLPOB) and SHP become active during the optical black pixel interval, and then the dummy clamp function becomes active.

The active polarity of CLPDM and SHP (Active HIGH or Active LOW) can be selected through the serial interface (refer to the "Serial Interface" section for more detail). The default value of CLPDM and SHP is "Active LOW". However, immediately after power on, this value is "Unknown". For this reason, the appropriate value must be set by using the serial interface, or reset to the default value by the RESET pin. The description and the timing diagrams in this data sheet are all based on the polarity of Active LOW (default value).

HIGH PERFORMANCE ANALOG-TO-DIGITAL CONVERTER (ADC)

The Analog-to-Digital Converter (ADC) utilizes a fully differential and pipelined architecture. This ADC is well suited for low-voltage operations, low-power consumption requirements, and high-speed applications. It guarantees 10-bit resolution of output data with no missing code. The VSP2210 includes a reference voltage generator for the ADC. REFP (Positive Reference, pin 38), REFN (Negative Reference, pin 39), and CM (Common-Mode Voltage, pin 37) should be bypassed to ground with a 0.1µF ceramic capacitor, and should not be used elsewhere in the system; they affect the stability of these reference levels, and cause ADC performance degradation. Note that these are analog output pins.

PROGRAMMABLE GAIN AMPLIFIER (PGA)

Figure 2 shows the characteristics of the PGA gain. The PGA provides a gain range of -6dB to +42dB, which is linear in dB. The gain is controlled by a digital code with 10-bit resolution, and can be set through the serial interface (refer to the “Serial Interface” section for more detail). The default value of the gain control code is 128 (PGA Gain = 0dB). However, immediately after power on, this value is “Unknown”. For this reason, the appropriate value must be set by using the serial interface, or reset to the default value by the RESET pin.

OPTICAL BLACK (OB) LEVEL CLAMP LOOP

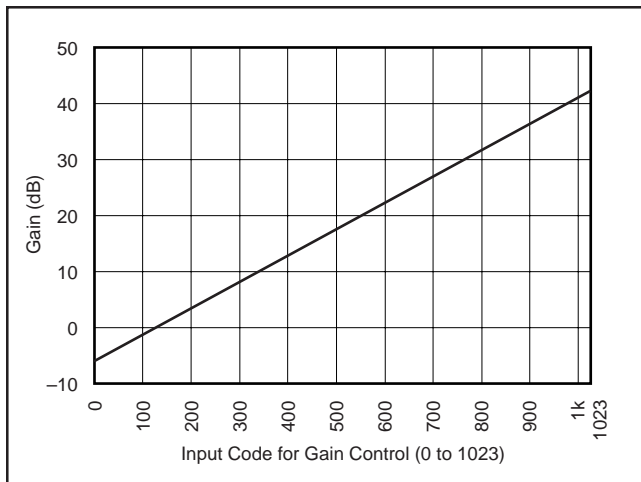

FIGURE 2. Characteristics of PGA Gain.

To extract the video information correctly, the CCD signal must be referenced to a well-established Optical Black (OB) level. The VSP2210 has an auto-calibration loop to establish the OB level using the optical black pixels output from the CCD imager. The input signal level of the OB pixels is identified as the real “OB level”, and the loop should be closed during this period while CLPOB is active.

During the effective pixel interval, the reference level of the CCD output signal is clamped to the OB level by the OB level clamp loop. To determine the loop time constant, an off-chip capacitor is required, and should be connected to COB (pin 28). Time constant T is given in the following equation:

$$T = C / (16384 \cdot I_{\min})$$

Where C is the capacitor value connected to COB, I_{\min} is the minimum current (0.15µA) of the control DAC in the OB level clamp loop, and 0.15µA is equivalent to 1LSB of the DAC output current. When C is 0.1µF, the time constant T is 40.7µs.

Additionally, the slew rate SR is given the following equation:

$$SR = I_{\max} / C$$

Where C is the capacitor value connected to COB, I_{\max} is the maximum current (153µA) of the control DAC in the OB level clamp loop, and 153µA is equivalent to 1023LSB of the DAC output current.

Generally, OB level clamping at high speed causes “Clamp Noise” (or “White Streak Noise”), however, the noise will decrease by increasing C. On the other hand, an increased C requires a much longer time to restore from Stand-By mode, or right after power on. Therefore, we consider 0.1µF to 0.22µF a reasonable value for C. However, it depends on the application environment; we recommend making careful adjustments using trial-and-error.

The “OB clamp level” (the pedestal level) is programmable through the serial interface (refer to the “Serial Interface” section for more detail). Table I shows the relationship between input code and the OB clamp level.

INPUT CODE	OB CLAMP LEVEL, LSBs OF 10 BITS
0000	0 LSB
0001	4 LSB
0010	8 LSB
0011	12 LSB
0100	16 LSB
0101	20 LSB
0110	24 LSB
0111	28 LSB
1000 (Default)	32 LSB
1001	36 LSB
1010	40 LSB
1011	44 LSB
1100	48 LSB
1101	52 LSB
1110	56 LSB
1111	60 LSB

TABLE I. Programmable OB Clamp Level.

The active polarity of CLPOB (Active HIGH or Active LOW) can be selected through the serial interface (refer to the “Serial Interface” section for more detail). The default value of CLPOB is “Active LOW”. However, immediately after power on, this value is “Unknown”. For this reason, the appropriate value must be set by using serial interface, or reset to the default value by the RESET pin. The description and the timing diagrams in this data sheet are all based on the polarity of Active LOW (default value).

PREBLANKING AND DATA LATENCY

Some CCDs have large transient output signals during blanking intervals. Such signals may exceed the VSP2210’s 1Vp-p input signal range and would overdrive the VSP2210 into saturation. Recovery time from the saturation could be substantial. To avoid this, the VSP2210 has an input blanking (or preblanking) function (PBLK). When PBLK goes to LOW, the CCDIN input is disconnected from the internal CDS stage and large transients are prevented from passing through. The VSP2210’s digital outputs will go to all ZEROs at the 11th rising edge of ADCK, from just after PBLK sets to LOW, to accommodate the clock latency of the VSP2210. In this mode, the digital output data come out at the rising edge of ADCK with a delay of 11 clock cycles (data latency is 11). Note that in the normal operation mode, the digital output data come out at the rising edge of ADCK with a delay of 9 clock cycles (data latency is 9).

It is recommended that CLPOB should not be activated during PBLK active period in order to keep a stable and accurate OB clamp level. Since the CCDIN input is disconnected from the internal circuit, even if the auto-calibration loop is closed while CLPOB is active, the OB clamp level is different from the “actual” OB level established by CCD imager output. The missed OB clamp level would affect the picture quality.

If the input voltage is higher than the supply rail by 0.3V, or lower than the ground rail by 0.3V, protection diodes will be turned on to prevent the input voltage from going further. Such a high swing signal may cause device damage to the VSP2210 and should be avoided.

STAND-BY MODE

For the purpose of power saving, the VSP2210 can be set to Stand-By mode (or Power-Down mode) through the serial interface when the VSP2210 is not in use. Refer to “Serial Interface” section for more detail. In this mode, all the function blocks are disabled and the digital outputs will go to all ZEROs. The consumption current will drop to 1mA. Since all the bypass capacitors will discharge during this mode, a substantial time (usually of the order of 200ms to 300ms) is required to power up from Stand-By mode.

VOLTAGE REFERENCE

All the reference voltages and bias currents needed in the VSP2210 are generated by its internal bandgap circuitry. The CDS and the ADC use mainly three reference voltages: REFP (Positive Reference, pin 38), REFN (Negative Reference, Pin 39) and CM (Common-Mode Voltage, pin 37). REFP, REFN and CM should be heavily decoupled with appropriate capacitors (e.g., 0.1 μ F ceramic capacitor), and should not be used elsewhere in the system; they affect the stability of the reference level, and cause ADC performance degradation. Note that these are analog output pins.

BYPP2 (pin 29), BYP(pin 31), BYPM(pin 32) are also reference voltages to be used in the analog circuit. BYP should be connected to ground with 0.1 μ F ceramic capacitor. The capacitor value for BYPP2 and BYPM affects the step response. Therefore, we consider 1000pF is the reasonable value. However, it depends on the application environment; we recommend making careful adjustments using trial-and-error.

All of BYPP2, BYP and BYPM should be heavily decoupled with appropriate capacitors, and not used elsewhere in the system. They affect the stability of these reference level, and cause performance degradation. Note that these are analog output pins.

SERIAL INTERFACE

The serial interface has a 2-byte shift register and various parallel registers to control all the digitally programmable features of the VSP2210. Writing to these registers is controlled by four signals (SLOAD, SCLK, SDATA, RESET). To enable the shift register, SLOAD must be pulled LOW. SDATA is the serial data input and the SCLK is the shift clock. The data at SDATA is taken into the shift register at the rising edge of SCLK. The data length should be 2 bytes. After the 2-byte shift operation, the data in the shift register is transferred to the parallel latch at the rising edge of SLOAD. In addition to the parallel latch, there are several registers dedicated to the specific features of the device and they are synchronized with ADCK. It takes 5 or 6 clock cycles for the data in the parallel latch to be written to those registers. Therefore, to complete the data updates, it requires 5 or 6 clock cycles after the parallel latching by the rising edge of SLOAD.

See Table II for the serial interface data format. TEST is the flag for the test mode (Burr-Brown proprietary only), A0 to A2 is the address for the various registers, and D0 to D11 is the data or the operand field.

REGISTERS	TEST	A2	A1	A0	D11	D10	D9	D8	D7	D6	D5	D4	D3	D2	D1	D0
Configuration	0	0	0	0	0	0	0	0	0	0	0	0	0	C2	C1	C0
PGA Gain	0	0	0	1	0	0	G9	G8	G7	G6	G5	G4	G3	G2	G1	G0
OB Clamp Level	0	0	1	0	0	0	0	0	0	0	0	0	O3	O2	O1	O0
Clock Polarity	0	0	1	1	0	0	0	0	0	0	0	0	0	P2	P1	P0
DAC0 Data	0	1	0	0	0	0	0	0	E7	E6	E5	E4	E3	E2	E1	E0
DAC1 Data	0	1	0	1	0	0	0	0	F7	F6	F5	F4	F3	F2	F1	F0
Reserved	0	1	1	0	x	x	x	x	x	x	x	x	x	x	x	x
Reserved	1	x	x	x	x	x	x	x	x	x	x	x	x	x	x	x

x = Don't Care.

TABLE II. Serial Interface Data Format.

REGISTER DEFINITIONS

C[2:0] Operation Mode, Normal/Stand-By

Serial Interface and Registers are always active, independently from the operation mode.

C0 = Operation Mode for the entire chip except DAC0/DAC1

(C0 = 0 “Active”; C0 = 1 “Stand-by”)

C1 = for DAC0 (C0 = 0 “Active”; C0 = 1 “Stand-by”)

C2 = for DAC1 (C0 = 0 “Active”; C0 = 1 “Stand-by”)

G[9:0] The Characteristics of PGA Gain (refer to Figure 2)

O[3:0] Programmable OB Clamp Level (refer to Table I)

P[2:0] Clock Polarity

P0 = Polarity for CLPDM (P0 = 0 “Active LOW”; P0 = 1 “Active HIGH”)

P1 = for CLPOB (P0 = 0 “Active LOW”; P0 = 1 “Active HIGH”)

P2 = for SHP/SHD (P0 = 0 “Active LOW”; P0 = 1 “Active HIGH”)

E[7:0] DAC0 Data (All ZEROs = Output Voltage Minimum; All ONES = Output Voltage Maximum)

F[7:0] DAC1 Data (All ZEROs = Output Voltage Minimum; All ONES = Output Voltage Maximum)

Immediately after power on, these values are “Unknown”. The appropriate value must be set by using the serial interface, or reset to the default value by the RESET pin.

Default values are:	
C[2:0] = 000	Normal Operation Mode
G[9:0] = 0010000000	PGA Gain = 0dB
O[3:0] = 1000	OB Clamp Level = 32LSB
P[2:0] = 000	CLPDM, CLPOB, SHP/SHD are all “Active LOW” ⁽¹⁾
E[7:0] = 00000000	DAC0 Output Voltage = Minimum
F[7:0] = 00000000	DAC1 Output Voltage = Minimum

NOTE: (1) The description and the timing diagrams in this data sheet are all based on the polarity of Active LOW (default value).

TIMINGS

The CDS and the ADC are operated by SHP/SHD and their derivative timing clocks generated by the on-chip timing generator. The digital output data is synchronized with ADCCK. The timing relationship among the CCD signal, SHP/SHD, ADCCK and the output data is shown in the VSP2210 “CDS Timing Specifications”. CLPOB is used to activate the black level clamp loop during the OB pixel interval, and CLPDM is used to activate the input clamping during the dummy pixel interval. If the CLPDM pulse is not available in your system, the CLPOB pulse can be used in place of CLPDM as long as the clamping takes place during black pixels (refer to the “Input Clamp and Dummy Pixel Clamp” section for more detail). The clock polarities of SHP/SHD, CLPOB and CLPDM can be independently set through the serial interface (refer to the “Serial Interface” section for more detail). The description and the timing diagrams in this data sheet are all based on the polarity of Active LOW (default value). In order to keep a stable and accurate OB clamp level, we recommend CLPOB should not be activated during PBLK active period. Refer to the “Preblanking and Data Latency” section for more detail. In Stand-By mode, all of ADCCK, SHP, SHD, CLPOB and CLPDM are internally masked and pulled HIGH.

GENERAL-PURPOSE 8-BIT DIGITAL-TO-ANALOG CONVERTER (DAC0,DAC1)

The VSP2210 incorporates two identical 8-bit Digital-to-Analog converters (DACs). These DACs are for user-definable options such as iris control and sub-bias voltage control of the CCD imager. The input data for these DACs is set by the written data through the serial interface (refer to the “Serial Interface” section for more detail). DAC input data that is all ZEROs corresponds to a minimum output voltage of 0.1V. In a similar manner, all ONES correspond to a maximum output voltage of 2.9V. Figure 3 shows the characteristics.

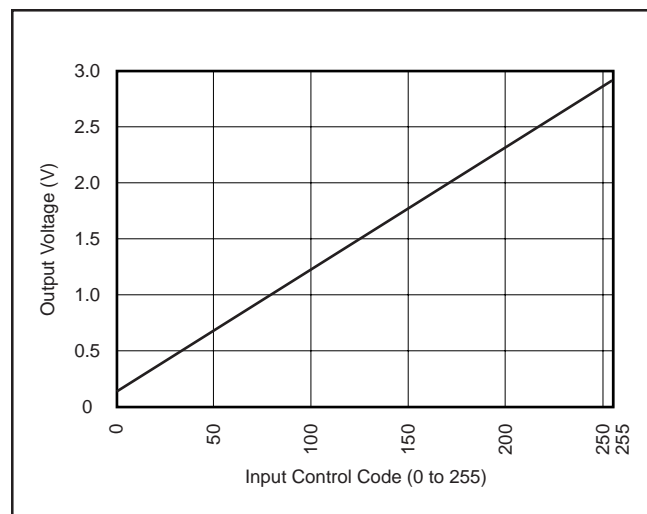

FIGURE 3. Characteristics for general-purpose 8-bit DAC (DAC0, DAC1).

POWER SUPPLY, GROUNDING AND DEVICE DECOUPLING RECOMMENDATIONS

The VSP2210 incorporates a very high-precision and high-speed Analog-to-Digital converter and analog circuitry that are vulnerable to any extraneous noise from the rails or elsewhere. For this reason, it should be treated as an analog component and all supply pins except for DRV_{DD} should be powered by the only analog supply of the system. This will ensure the most consistent results, since digital power lines often carry high level of wide band noise that would otherwise be coupled into the device and degrade the achievable performance. Proper grounding, short lead length and the use of ground planes are also very important for high-frequency designs. Multilayer PC boards are recommended for the best performance, since they offer distinct advantages like minimizing ground impedance, separation of signal layers by ground layers, etc. It is highly recommended that analog and digital ground pins of the VSP2210 be joined together at the IC and be connected only to the analog ground of the system. The driver stage of the digital outputs (B[9:0]) is supplied through a dedicated supply pin (DRV_{DD}) and it should be separated from the other supply pins completely, or at least with a ferrite bead. It is also recommended to keep the capacitive loading on the output data lines as low as possible (typically less than 15pF). Larger capacitive loads demand higher charging current surges that can feed back into the analog portion of the VSP2210 and affect the performance. If possible, external buffers or latches should be used, providing the added benefit of isolating the VSP2210 from any digital noise activities on the data lines. In addition, resistors in series with each data line may help minimizing the surge current. Values in the range of 100 Ω to 200 Ω will limit the instantaneous current the output stage has to provide for recharging the parasitic capacitances as the output levels change from LOW to HIGH, or HIGH to LOW. Due to high operation speed, the converter also generates high-frequency current transients and noises that are fed back into the supply and reference lines. This requires the supply and reference pins be sufficiently bypassed. In most cases, 0.1 μ F ceramic chip capacitors are adequate to decouple the reference pins. Supply pins should be decoupled to the ground plane with a parallel combination of tantalum (1 μ F to 22 μ F) and ceramic (0.1 μ F) capacitors. The effectiveness of the decoupling largely depends on the proximity to the individual pin. DRV_{DD} should be decoupled to the proximity of $DRVGND$. Special attention must be paid to the bypassing of COB, BYPP2 and BYPM, since these capacitor values determine important analog performances of the device.

PACKAGING INFORMATION

Orderable Device	Status ⁽¹⁾	Package Type	Package Drawing	Pins	Package Qty	Eco Plan ⁽²⁾	Lead/Ball Finish	MSL Peak Temp ⁽³⁾
VSP2210Y	ACTIVE	LQFP	PT	48	250	None	CU SNPB	Level-1-235C-UNLIM
VSP2210Y/2K	ACTIVE	LQFP	PT	48	2000	None	CU SNPB	Level-1-235C-UNLIM

⁽¹⁾ The marketing status values are defined as follows:

ACTIVE: Product device recommended for new designs.

LIFEBUY: TI has announced that the device will be discontinued, and a lifetime-buy period is in effect.

NRND: Not recommended for new designs. Device is in production to support existing customers, but TI does not recommend using this part in a new design.

PREVIEW: Device has been announced but is not in production. Samples may or may not be available.

OBSELETE: TI has discontinued the production of the device.

⁽²⁾ Eco Plan - May not be currently available - please check <http://www.ti.com/productcontent> for the latest availability information and additional product content details.

None: Not yet available Lead (Pb-Free).

Pb-Free (RoHS): TI's terms "Lead-Free" or "Pb-Free" mean semiconductor products that are compatible with the current RoHS requirements for all 6 substances, including the requirement that lead not exceed 0.1% by weight in homogeneous materials. Where designed to be soldered at high temperatures, TI Pb-Free products are suitable for use in specified lead-free processes.

Green (RoHS & no Sb/Br): TI defines "Green" to mean "Pb-Free" and in addition, uses package materials that do not contain halogens, including bromine (Br) or antimony (Sb) above 0.1% of total product weight.

⁽³⁾ MSL, Peak Temp. -- The Moisture Sensitivity Level rating according to the JEDEC industry standard classifications, and peak solder temperature.

Important Information and Disclaimer:The information provided on this page represents TI's knowledge and belief as of the date that it is provided. TI bases its knowledge and belief on information provided by third parties, and makes no representation or warranty as to the accuracy of such information. Efforts are underway to better integrate information from third parties. TI has taken and continues to take reasonable steps to provide representative and accurate information but may not have conducted destructive testing or chemical analysis on incoming materials and chemicals. TI and TI suppliers consider certain information to be proprietary, and thus CAS numbers and other limited information may not be available for release.

In no event shall TI's liability arising out of such information exceed the total purchase price of the TI part(s) at issue in this document sold by TI to Customer on an annual basis.

IMPORTANT NOTICE

Texas Instruments Incorporated and its subsidiaries (TI) reserve the right to make corrections, modifications, enhancements, improvements, and other changes to its products and services at any time and to discontinue any product or service without notice. Customers should obtain the latest relevant information before placing orders and should verify that such information is current and complete. All products are sold subject to TI's terms and conditions of sale supplied at the time of order acknowledgment.

TI warrants performance of its hardware products to the specifications applicable at the time of sale in accordance with TI's standard warranty. Testing and other quality control techniques are used to the extent TI deems necessary to support this warranty. Except where mandated by government requirements, testing of all parameters of each product is not necessarily performed.

TI assumes no liability for applications assistance or customer product design. Customers are responsible for their products and applications using TI components. To minimize the risks associated with customer products and applications, customers should provide adequate design and operating safeguards.

TI does not warrant or represent that any license, either express or implied, is granted under any TI patent right, copyright, mask work right, or other TI intellectual property right relating to any combination, machine, or process in which TI products or services are used. Information published by TI regarding third-party products or services does not constitute a license from TI to use such products or services or a warranty or endorsement thereof. Use of such information may require a license from a third party under the patents or other intellectual property of the third party, or a license from TI under the patents or other intellectual property of TI.

Reproduction of information in TI data books or data sheets is permissible only if reproduction is without alteration and is accompanied by all associated warranties, conditions, limitations, and notices. Reproduction of this information with alteration is an unfair and deceptive business practice. TI is not responsible or liable for such altered documentation.

Resale of TI products or services with statements different from or beyond the parameters stated by TI for that product or service voids all express and any implied warranties for the associated TI product or service and is an unfair and deceptive business practice. TI is not responsible or liable for any such statements.

Following are URLs where you can obtain information on other Texas Instruments products and application solutions:

Products		Applications	
Amplifiers	amplifier.ti.com	Audio	www.ti.com/audio
Data Converters	dataconverter.ti.com	Automotive	www.ti.com/automotive
DSP	dsp.ti.com	Broadband	www.ti.com/broadband
Interface	interface.ti.com	Digital Control	www.ti.com/digitalcontrol
Logic	logic.ti.com	Military	www.ti.com/military
Power Mgmt	power.ti.com	Optical Networking	www.ti.com/opticalnetwork
Microcontrollers	microcontroller.ti.com	Security	www.ti.com/security
		Telephony	www.ti.com/telephony
		Video & Imaging	www.ti.com/video
		Wireless	www.ti.com/wireless

Mailing Address: Texas Instruments
Post Office Box 655303 Dallas, Texas 75265

Looking for pricing, stock, or lifecycle information?

Click below to explore more details on WIN SOURCE:

 [View VSP2210Y/2K on WIN SOURCE](#)

 [Texas Instruments](#) Information

Optimize Your Supply Chain with WIN SOURCE Solutions

-  Global Sourcing Solution
-  Obsolete Management
-  Cost Control Management
-  Shortage Management
-  Alternative Solution
-  Excess Inventory Management