



**THE DATASHEET OF
VNQ05XSP16TR-E**





VNQ05XSP16

QUAD CHANNEL HIGH SIDE SOLID STATE RELAY

TYPE	R _{ON} (*)	I _{OUT}	V _{CC}
VNQ05XSP16	110mΩ	5A (*)	36 V

(*) Per each channel

- OUTPUT CURRENT (CONTINUOUS): 5A
- CMOS COMPATIBLE INPUTS
- MULTIPLEXED PROPORTIONAL LOAD CURRENT SENSE
- UNDERVOLTAGE & OVERVOLTAGE SHUT-DOWN
- OVERVOLTAGE CLAMP
- THERMAL SHUT DOWN
- CURRENT LIMITATION
- VERY LOW STAND-BY POWER DISSIPATION
- PROTECTION AGAINST:
 - LOSS OF GROUND & LOSS OF V_{CC}
- REVERSE BATTERY PROTECTION (**)

DESCRIPTION

The VNQ05XSP16 is a monolithic device designed in STMicroelectronics VIPower M0-3

ABSOLUTE MAXIMUM RATING

Symbol	Parameter	Value	Unit
V _{CC}	Supply voltage (continuous)	41	V
-V _{CC}	Reverse supply voltage (continuous)	-0.3	V
I _{OUT}	Output current (continuous), for each channel	Internally limited	A
I _R	Reverse output current (continuous), for each channel	-5	A
I _{IN}	Input current (IN1,IN2,IN3,IN4,SELA,SELB,SENSEENABLE)	+/- 10	mA
V _{CSENSE}	Current sense maximum voltage	-3 +15	V V
I _{GND}	Ground current at T _{case} ≤25°C (continuous)	-200	mA
V _{ESD}	Electrostatic Discharge (Human Body Model: R=1.5Ω; C=100pF)		
	- INPUT	4000	V
	- CURRENT SENSE	2000	V
	- OUTPUT	5000	V
	- V _{CC}	5000	V
P _{tot}	Power dissipation at T _{case} =25°C	78	W
E _{MAX}	Maximum Switching Energy (L=1.72mH; R _L =0Ω; V _{bat} =13.5V; T _{jstart} =150°C; I _L =7.5A)	76	mJ
T _j	Junction operating temperature	Internally limited	°C
T _c	Case Operating Temperature	- 40 to 150	°C
T _{STG}	Storage temperature	-55 to 150	°C

(**) See application schematic at page 9

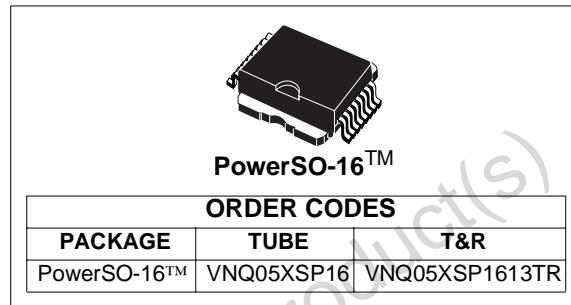

Technology. It is intended for driving any type of multiple loads with one side connected to ground. Active V_{CC} pin voltage clamp protects the device against low energy spikes (see ISO7637 transient compatibility table). This device has four independent channels and one multiplexed analog sense output which deliver a current proportional to the selected output current. SenseEnable pin allows to connect any number of VNQ05XSP16 on the same Current Sense line. Active current limitation combined with thermal shut-down and automatic restart protect the device against overload. Device automatically turns off in case of ground pin disconnection.

BLOCK DIAGRAM

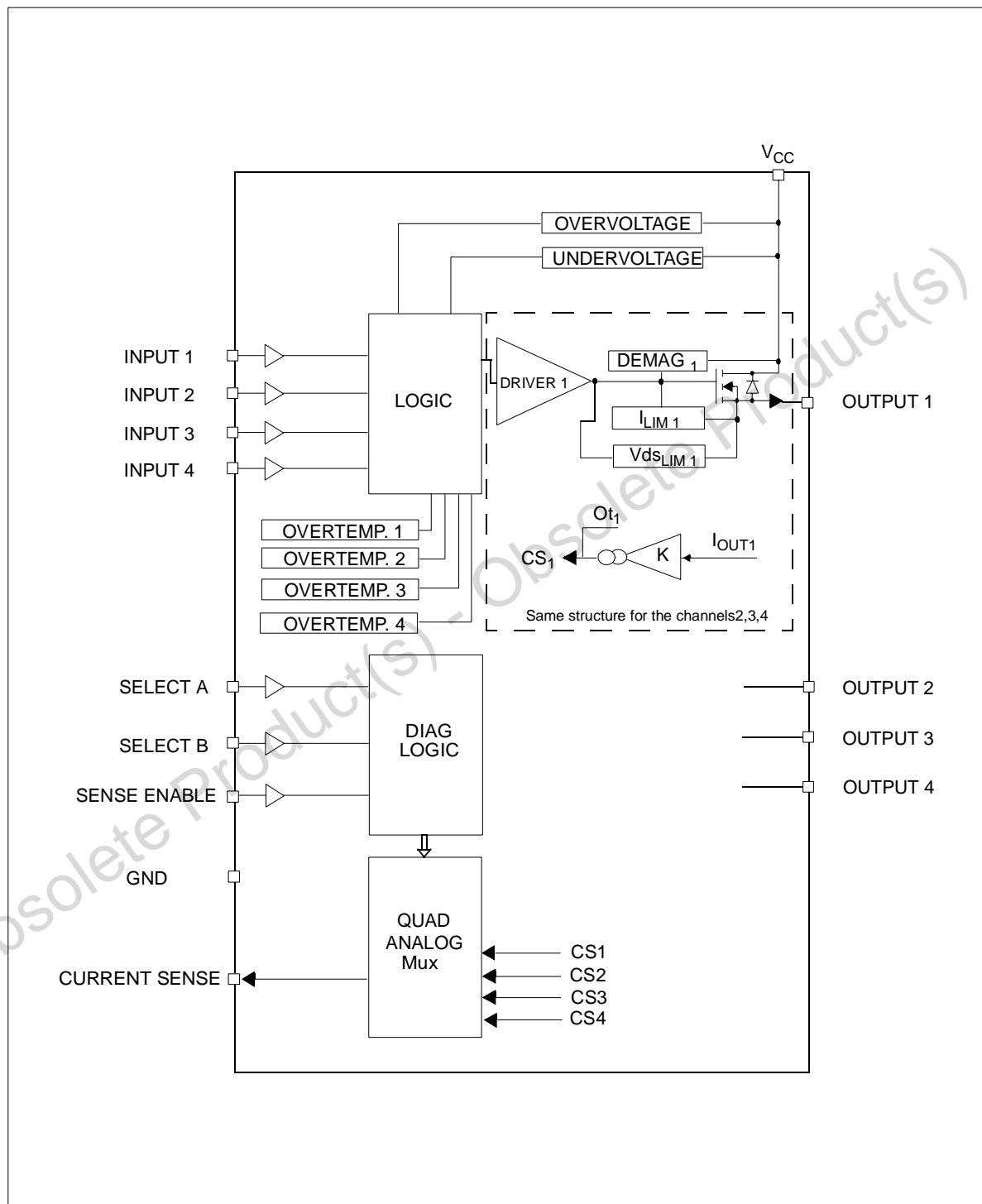

CURRENT AND VOLTAGE CONVENTIONS

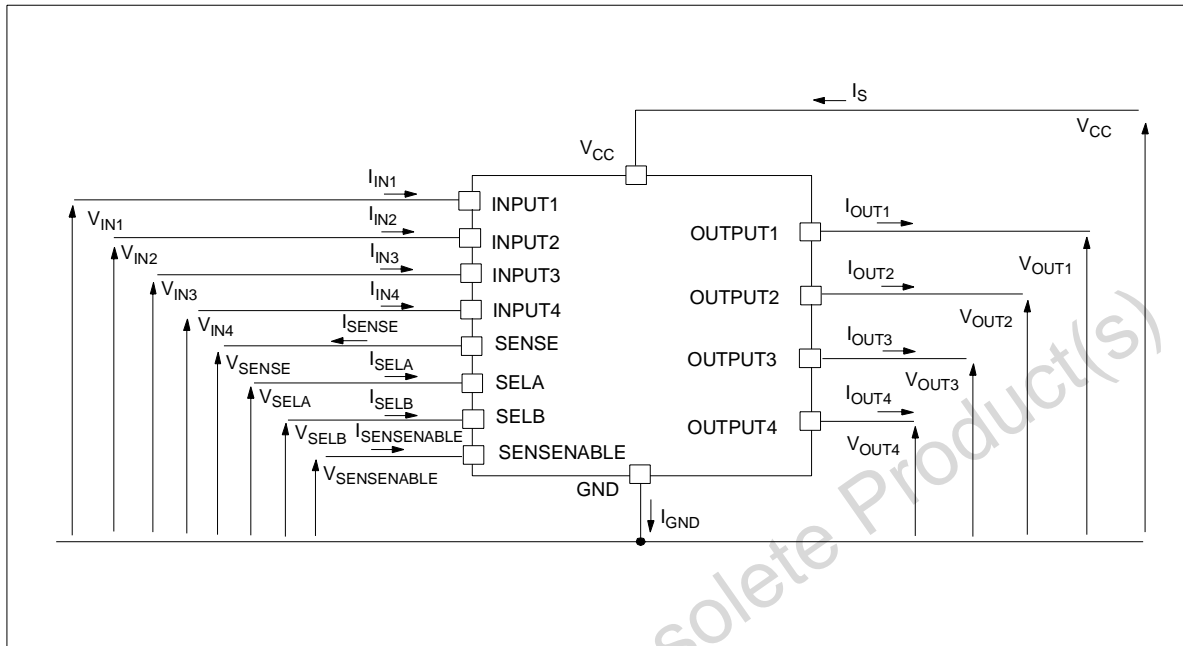

CONNECTION DIAGRAM (TOP VIEW)

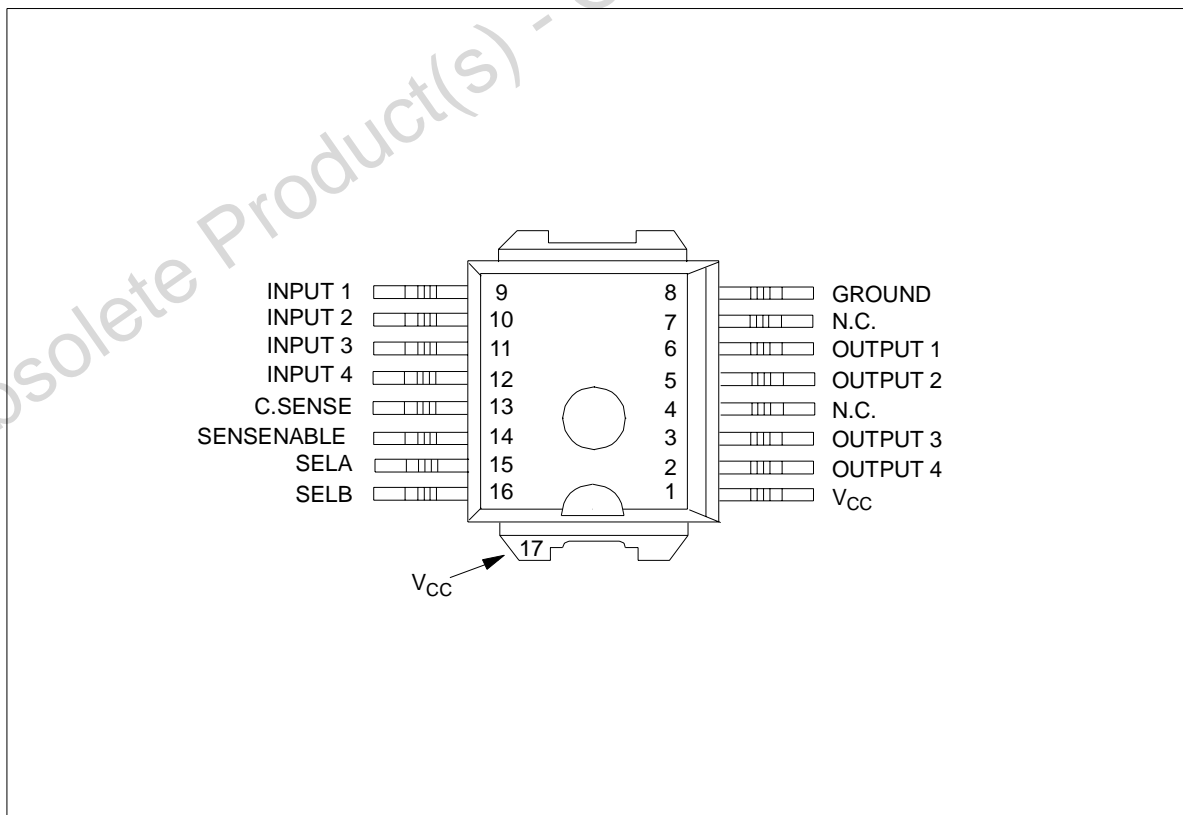

VNQ05XSP16

THERMAL DATA

Symbol	Parameter	Value	Unit
R _{thj-case}	Thermal resistance junction-case (MAX)	1.6	°C/W
R _{thj-amb}	Thermal resistance junction-ambient (MAX)	51.6 (*)	°C/W

(*) When mounted on FR4 printed circuit board with 0.5 cm² of copper area (at least 35 μm thick) connected to all V_{CC} pins

ELECTRICAL CHARACTERISTICS (8V < V_{CC} < 36V; -40°C < T_j < 150°C; unless otherwise specified) (Per each channel)

Symbol	Parameter	Test Conditions	Min	Typ	Max	Unit
V _{CC}	Operating supply voltage		5.5	13	36	V
V _{USD}	Under voltage shut down		3	4	5.5	V
V _{OV}	Overvoltage shut down		36			V
R _{ON}	On state resistance	I _{OUT1,2,3,4} =1A; T _j =25°C I _{OUT1,2,3,4} =1A; T _j =150°C I _{OUT1,2,3,4} =0.5A; V _{CC} =6V			110 220 330	mΩ
V _{clamp}	Clamp Voltage	I _{CC} =20mA (See note 1)	41	48	55	V
I _S	Supply current	Off state; Inputs=n.c.; V _{CC} =13V On state; V _{IN} =5V; V _{CC} =13V; I _{OUT} =0A; R _{SENSE} =3.9kΩ			80 10	μA mA
I _{L(off1)}	Off State Output Current	V _{IN} =V _{OUT} =0V	0		50	μA
I _{L(off2)}	Off State Output Current	V _{IN} =0V; V _{OUT} =3.5V	-75		0	μA
I _{L(off3)}	Off State Output Current	V _{IN} =V _{OUT} =0V; V _{CC} =13V; T _j =125°C			5	μA
I _{L(off4)}	Off State Output Current	V _{IN} =V _{OUT} =0V; V _{CC} =13V; T _j =25°C			3	μA

SWITCHING (V_{CC}=13V)

Symbol	Parameter	Test Conditions	Min	Typ	Max	Unit
t _{d(on)}	Turn-on delay time	R _L =2.6Ω channels 1,2,3,4 (see figure 2)		40		μs
t _{d(off)}	Turn-off delay time	R _L =2.6Ω channels 1,2,3,4 (see figure 2)		40		μs
(dV _{OUT} /dt) _{on}	Turn-on voltage slope	R _L =2.6Ω channels 1,2,3,4 (see figure 2)		See relative diagram		V/μs
(dV _{OUT} /dt) _{off}	Turn-off voltage slope	R _L =2.6Ω channels 1,2,3,4 (see figure 2)		See relative diagram		V/μs

PROTECTIONS

Symbol	Parameter	Test Conditions	Min	Typ	Max	Unit
I _{lim}	DC short circuit current	V _{CC} =13V 5.5V < V _{CC} < 36V	5	7.5	10 10	A A
T _{TSD}	Thermal shut down temperature		150	175	200	°C
T _R	Thermal reset temperature		135			°C
T _{HYST}	Thermal hysteresis		7	15		°C
V _{demag}	Turn-off output voltage clamp	I _{OUT} =2A; L=6mH	V _{CC} -41	V _{CC} -48	V _{CC} -55	V
V _{ON}	Output voltage drop limitation	I _{OUT} =0.1A T _j =-40°C...+150°C		50		mV

Note 1: V_{clamp} and V_{OV} are correlated. Typical difference is 5V.

CURRENT SENSE ($9V < V_{CC} < 16V$)

Symbol	Parameter	Test Conditions	Min	Typ	Max	Unit
K_1	I_{OUT}/I_{SENSE}	$I_{OUT}=0.1A$; $V_{SENSE}=0.5V$ $T_j=-40\dots+150^\circ C$	650	950	1200	
dK_1/K_1	Current Sense Ratio Drift	$I_{OUT}=0.1A$; $V_{SENSE}=0.5V$; $T_j=-40^\circ C\dots+150^\circ C$	-10		+10	%
K_2	I_{OUT}/I_{SENSE}	$I_{OUT}=1.0A$, $V_{SENSE}=4V$ $T_j=-40\dots+150^\circ C$	800	1000	1200	
dK_2/K_2	Current Sense Ratio Drift	$I_{OUT}=1.0A$; $V_{SENSE}=4V$; $T_j=-40^\circ C\dots+150^\circ C$	-8		+8	%
K_3	I_{OUT}/I_{SENSE}	$I_{OUT}=2.0A$, $V_{SENSE}=4V$ $T_j=-40\dots+150^\circ C$	850	1000	1150	
dK_3/K_3	Current Sense Ratio Drift	$I_{OUT}=2.0A$; $V_{SENSE}=4V$; $T_j=-40^\circ C\dots+150^\circ C$	-6		+6	%
I_{SENSE0}	Analog Sense Leakage Current	$V_{CC}=6\dots16V$; $I_{OUT}=0A$; $V_{SENSE}=0V$; $T_j=-40^\circ C\dots+150^\circ C$	0		10	μA
$V_{SENSE1,2,3,4}$	Max analog sense output voltage	$V_{CC}=5.5V$, $I_{OUT1,2,3,4}=1.0A$ $R_{SENSE}=10k\Omega$ $V_{CC}>8V$, $I_{OUT1,2,3,4}=2.0A$ $R_{SENSE}=10k\Omega$	2			V
V_{SENSEH}	Analog sense output voltage in overtemperature condition	$V_{CC}=13V$; $R_{SENSE}=3.9k\Omega$		5.5		V
$R_{VSENSEH}$	Analog sense output impedance in overtemperature condition	$V_{CC}=13V$; $T_j>T_{TSD}$; All Channels Open		400		Ω
t_{DSENSE}	Current sense delay	$V_{CC}=13V$; $R_{SENSE}=3.9k\Omega$ (see note 2)		300	500	μs

LOGIC CHARACTERISTICS (Inputs, Sela&b, Sensenable)

Symbol	Parameter	Test Conditions	Min	Typ	Max	Unit
V_{IL}	Input low level voltage				1.25	V
V_{IH}	Input high level voltage		3.25			V
$V_{I(hyst)}$	Input hysteresis voltage		0.5			V
I_{IL}	Low level input current	$V_{IN}=1.25V$	1			μA
I_{IN}	High level input current	$V_{IN}=3.25V$			10	μA
V_{ICL}	Input clamp voltage	$I_{IN}=1mA$ $I_{IN}=-1mA$	6	6.8 -0.7	8	V V

Note 2: current sense signal delay after positive input slope.

Note: Sense pin doesn't have to be left floating.

TRUTH TABLE

CONDITIONS	INPUT	OUTPUT	SENSE
Normal operation	L	L	0
	H	H	Nominal
Overtemperature	L	L	0
	H	L	V_{SENSEH}
Undervoltage	L	L	0
	H	L	0
Overvoltage	L	L	0
	H	L	0
Short circuit to GND	L	L	0
	H	L	$(T_j < T_{TSD}) 0$
	H	L	$(T_j > T_{TSD}) V_{SENSEH}$
Short circuit to V_{CC}	L	H	0
	H	H	< Nominal
Negative output voltage clamp	L	L	0

TRUTH TABLE

SENSEABLE	SELB	SELA	SENSE
L	X	X	High Impedance
H	L	L	$I_{SENSE} = I_{OUT1}/K$
H	L	H	$I_{SENSE} = I_{OUT2}/K$
H	H	L	$I_{SENSE} = I_{OUT3}/K$
H	H	H	$I_{SENSE} = I_{OUT4}/K$

Figure 1: I_{OUT}/I_{SENSE} versus I_{OUT}

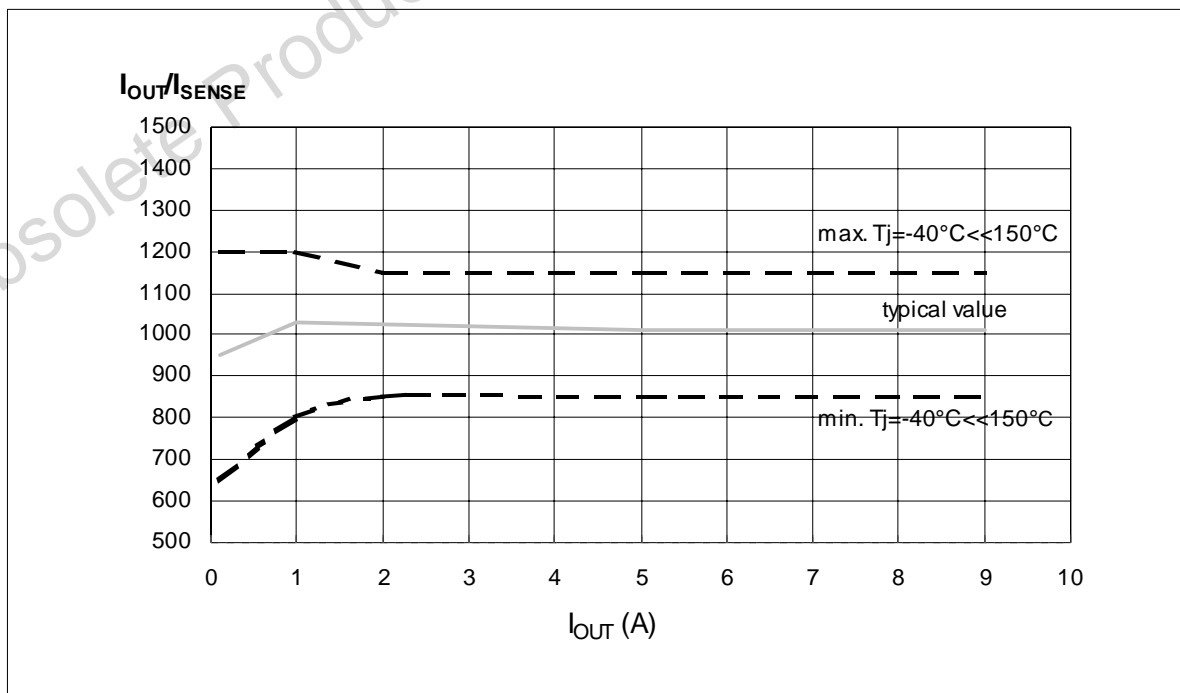

ELECTRICAL TRANSIENT REQUIREMENTS

ISO T/R 7637/1 Test Pulse	Test Levels I	Test Levels II	Test Levels III	Test Levels IV	Test Levels Delays and Impedance
1	-25V	-50V	-75V	-100V	2ms, 10 Ω
2	+25V	+50V	+75V	+100V	0.2ms, 10 Ω
3a	-25V	-50V	-100V	-150V	0.1 μ s, 50 Ω
3b	+25V	+50V	+75V	+100V	0.1 μ s, 50 Ω
4	-4V	-5V	-6V	-7V	10ms, 0.01 Ω
5	+26.5V	+46.5V	+66.5V	+86.5V	400ms, 2 Ω

ISO T/R 7637/1 Test Pulse	Test Levels Result I	Test Levels Result II	Test Levels Result III	Test Levels Result IV
1	C	C	C	C
2	C	C	C	C
3a	C	C	C	C
3b	C	C	C	C
4	C	C	C	C
5	C	E	E	E

Class	Contents
C	All functions of the device are performed as designed after exposure to disturbance.
E	One or more functions of the device is not performed as designed after exposure and cannot be returned to proper operation without replacing the device.

Figure 2: Switching Characteristics (Resistive load $R_L=1.3\Omega$)

Figure 3: Waveforms



APPLICATION SCHEMATIC

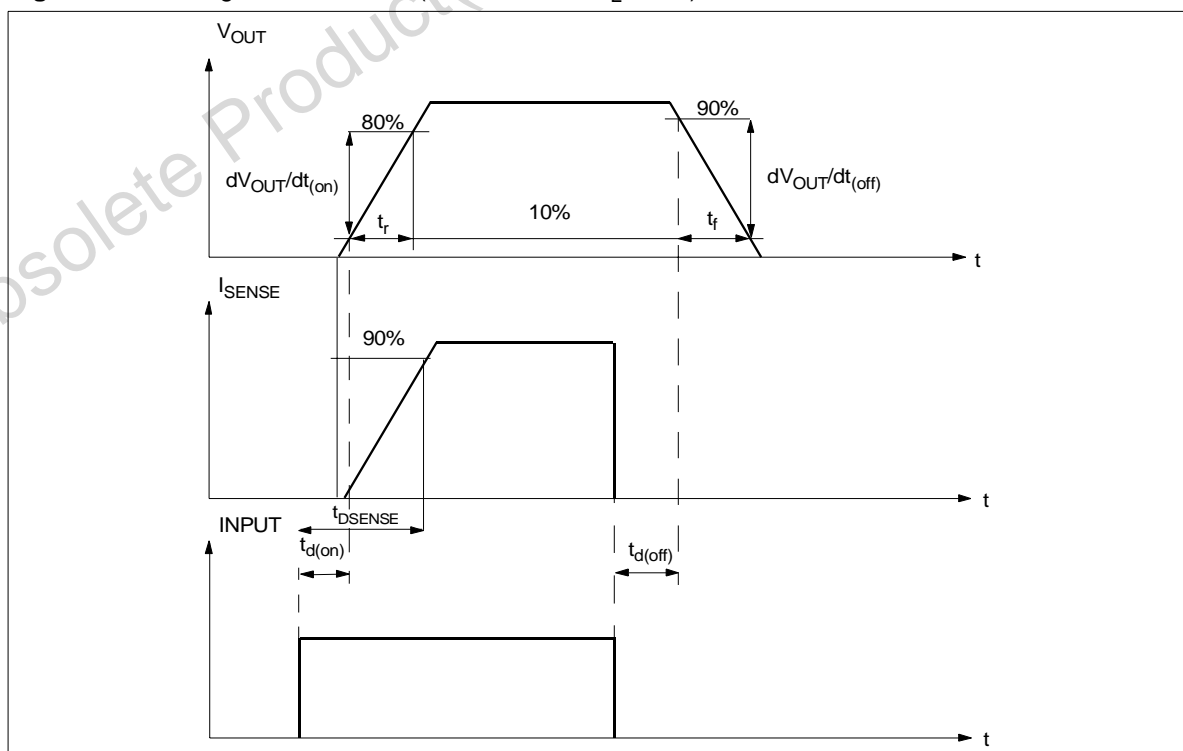
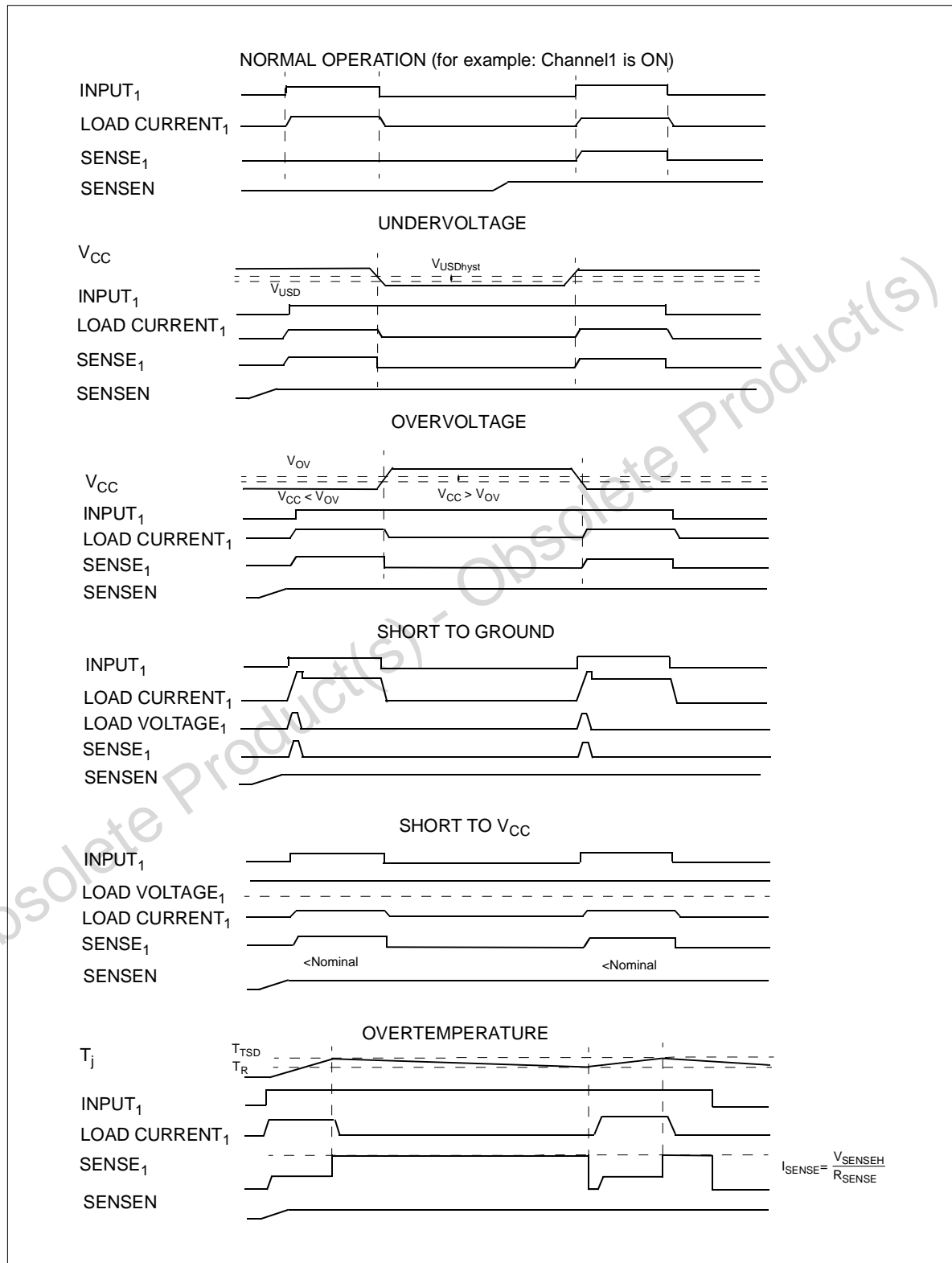
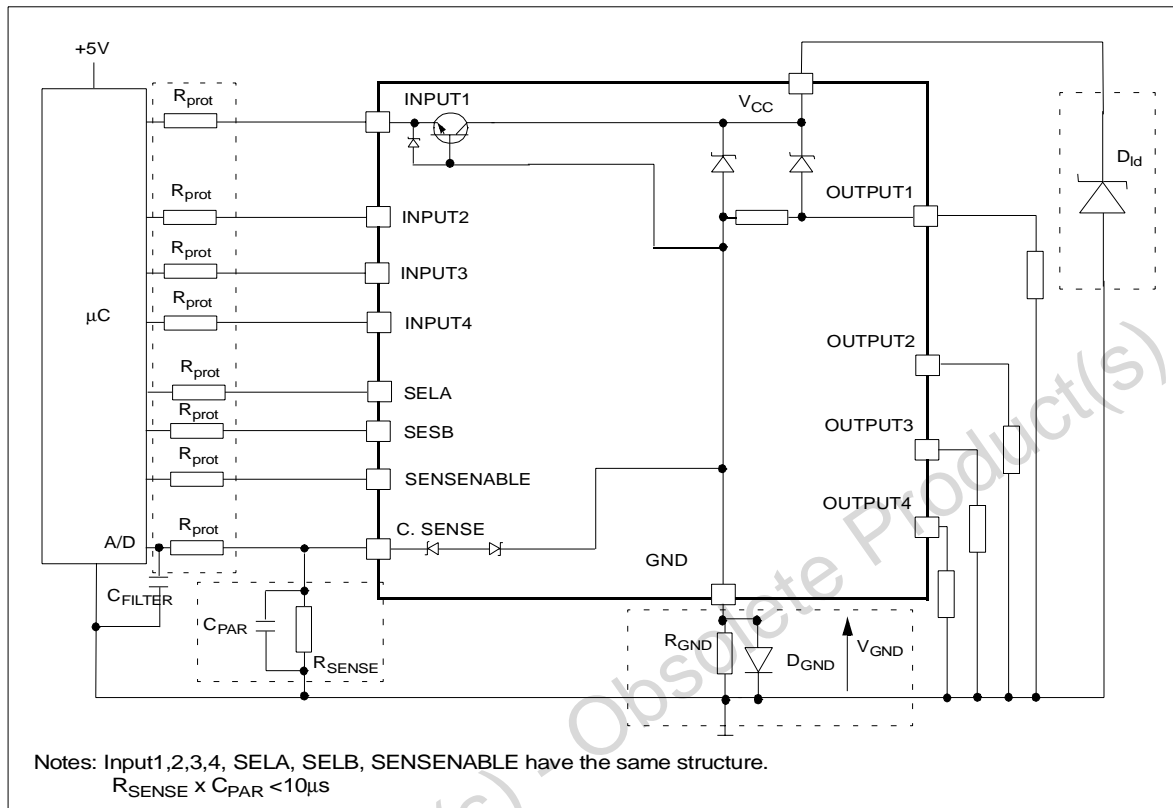

GND PROTECTION NETWORK AGAINST REVERSE BATTERY

Solution 1: Resistor in the ground line (R_{GND} only). This can be used with any type of load.

The following is an indication on how to dimension the R_{GND} resistor.

- 1) $R_{GND} \leq 600mV / (I_{S(on)max})$.
- 2) $R_{GND} \geq (-V_{CC}) / (-I_{GND})$

where $-I_{GND}$ is the DC reverse ground pin current and can be found in the absolute maximum rating section of the device's datasheet.

Power Dissipation in R_{GND} (when $V_{CC} < 0$: during reverse battery situations) is:

$$P_D = (-V_{CC})^2 / R_{GND}$$

This resistor can be shared amongst several different HSD. Please note that the value of this resistor should be calculated with formula (1) where $I_{S(on)max}$ becomes the sum of the maximum on-state currents of the different devices.

Please note that if the microprocessor ground is not common with the device ground then the R_{GND} will produce a shift ($I_{S(on)max} * R_{GND}$) in the input thresholds and the status output values. This shift will vary depending on how many devices are ON in the case of several high side drivers sharing the same R_{GND} .

If the calculated power dissipation leads to a large resistor or several devices have to share the same resistor then the ST suggests to utilize Solution 2 (see below).

Solution 2: A diode (D_{GND}) in the ground line.

A resistor ($R_{GND} = 1k\Omega$) should be inserted in parallel to D_{GND} if the device will be driving an inductive load.

This small signal diode can be safely shared amongst several different HSD. Also in this case, the presence of the ground network will produce a shift ($\approx 600mV$) in the input threshold and the status output values if the microprocessor ground is not common with the device ground. This shift will not vary if more than one HSD shares the same diode/resistor network.

LOAD DUMP PROTECTION

D_{Id} is necessary (Voltage Transient Suppressor) if the load dump peak voltage exceeds V_{CC} max DC rating. The same applies if the device will be subject to transients on the V_{CC} line that are greater than the ones shown in the ISO T/R 7637/1 table.

 μC I/Os PROTECTION:

If a ground protection network is used and negative transients are present on the V_{CC} line, the control pins will be pulled negative. ST suggests to insert a resistor (R_{prot}) in line to prevent the μC I/Os pins to latch-up.

The value of these resistors is a compromise between the leakage current of μC and the current required by the HSD I/Os (Input levels compatibility) with the latch-up limit of μC I/Os.

$$-V_{CCpeak} / I_{latchup} \leq R_{prot} \leq (V_{OH\mu C} - V_{IH} - V_{GND}) / I_{IHmax}$$

For $V_{CCpeak} = -100V$ and $I_{latchup} \geq 20mA$; $V_{OH\mu C} \geq 4.5V$
 $5k\Omega \leq R_{prot} \leq 65k\Omega$.

Recommended R_{prot} value is 10k Ω .

Off State Output Current

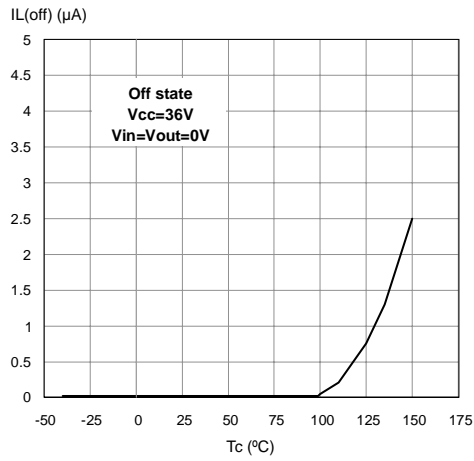

High Level Input Current

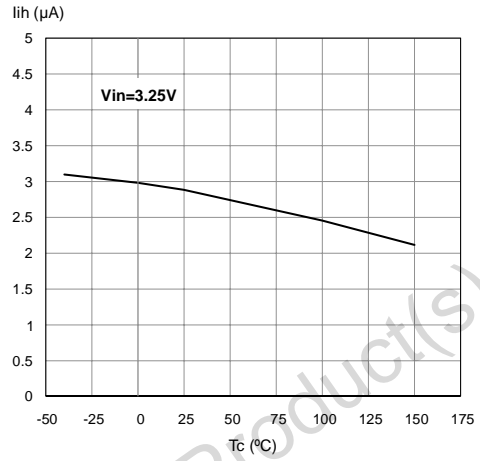

Input Clamp Voltage

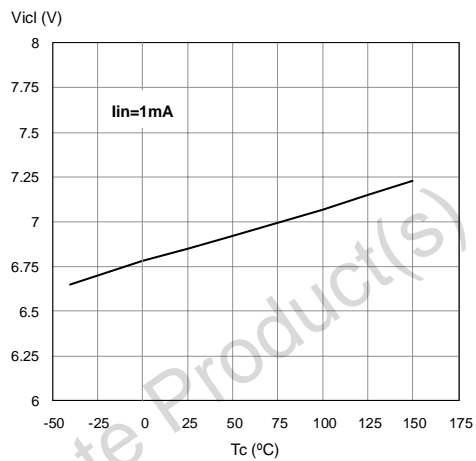

Input High Level

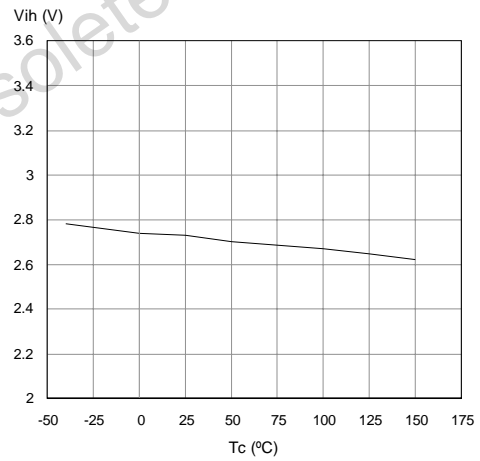

Overshoot Shutdown

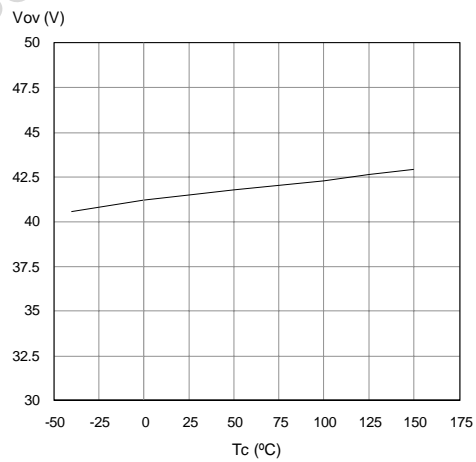

I_{LIM} Vs T_{case}

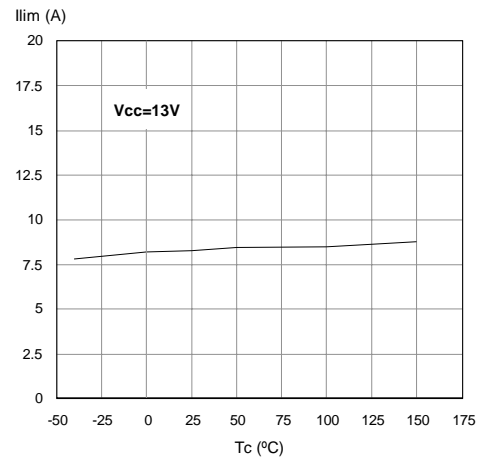

Turn-on Voltage Slope

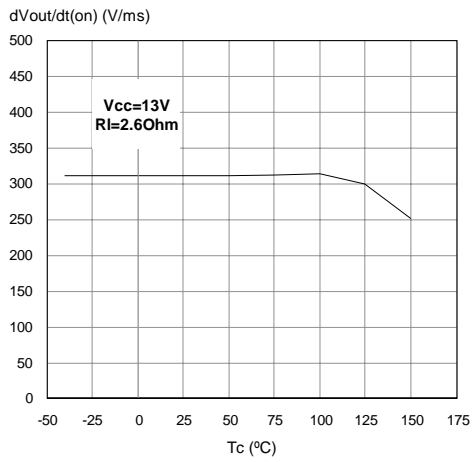

Turn-off Voltage Slope

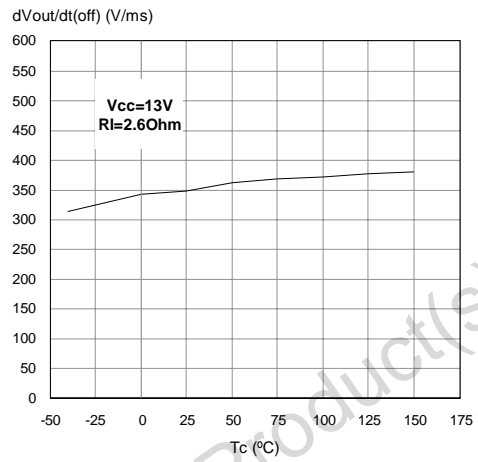

On State Resistance Vs T_{case}

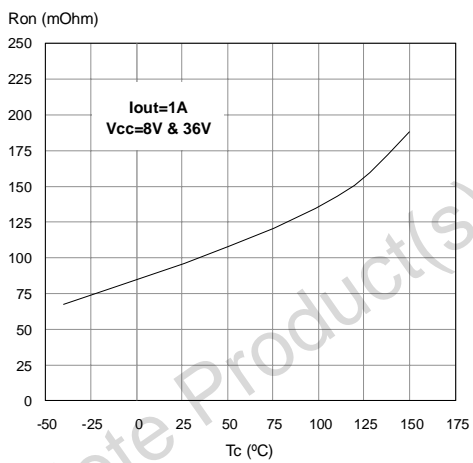

On State Resistance Vs V_{CC}

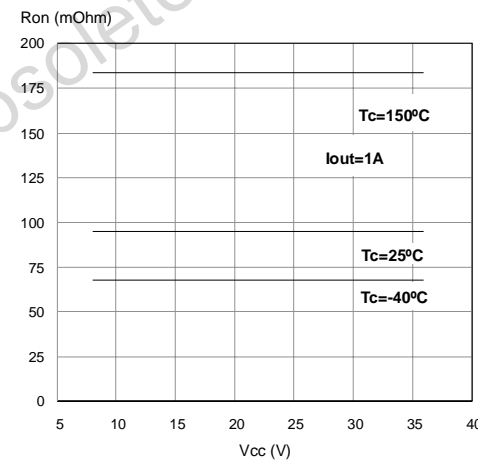

Maximum turn off current versus load inductance

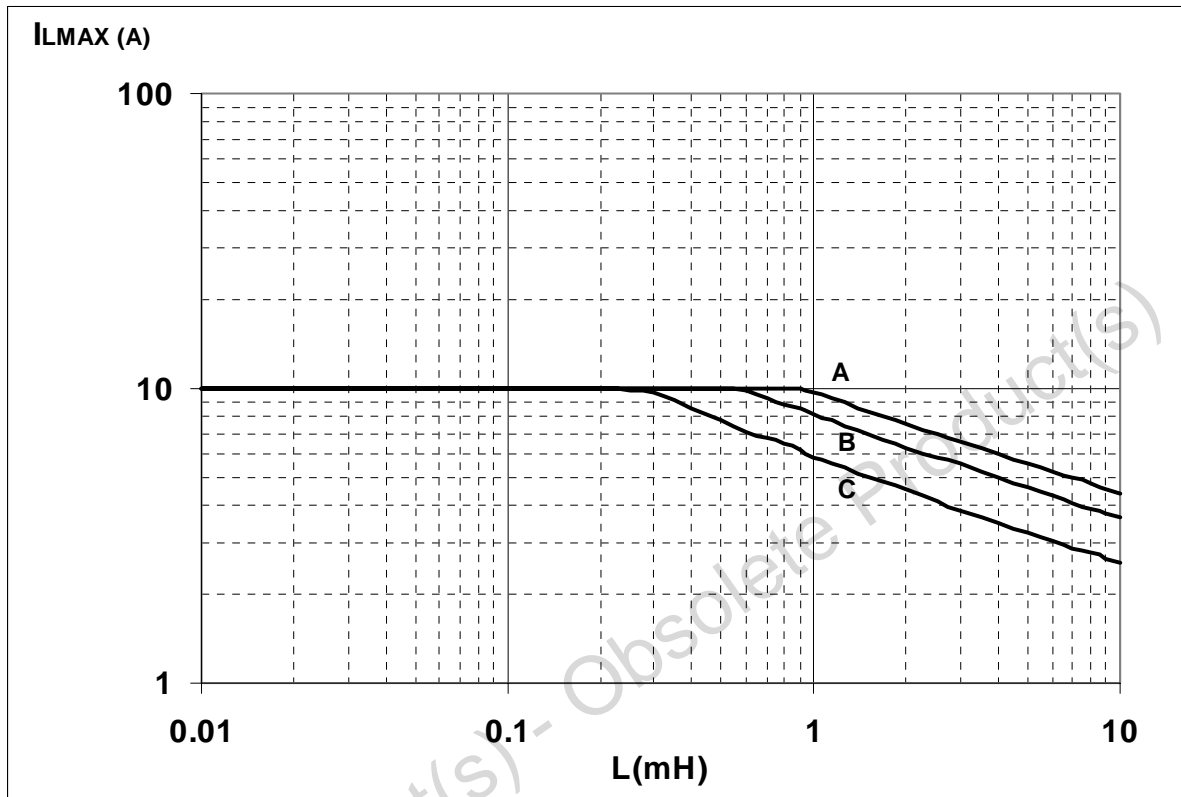

- A = Single Pulse at $T_{Jstart}=150^{\circ}C$
- B= Repetitive pulse at $T_{Jstart}=100^{\circ}C$
- C= Repetitive Pulse at $T_{Jstart}=125^{\circ}C$

Conditions:

$V_{CC}=13.5V$

Values are generated with $R_L=0\Omega$

In case of repetitive pulses, T_{jstart} (at beginning of each demagnetization) of every pulse must not exceed the temperature specified above for curves B and C.

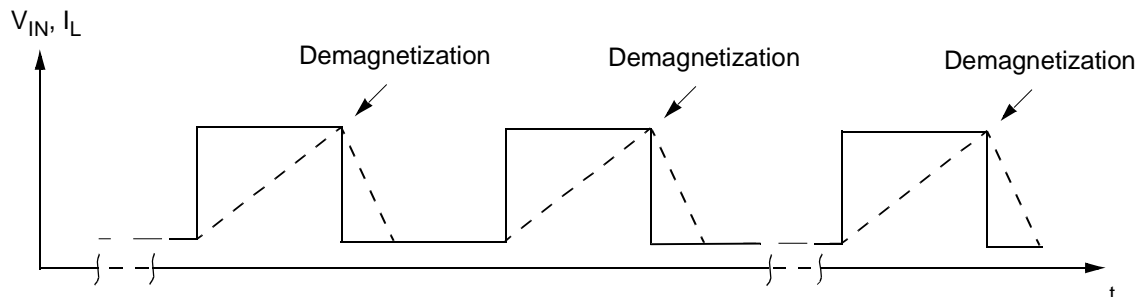

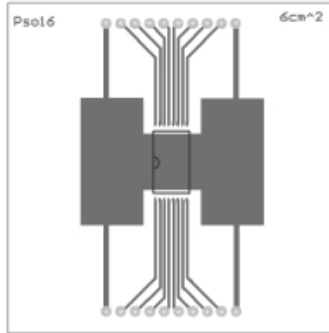
PowerSO-16™ THERMAL DATA**PowerSO-16™ PC Board**

Layout condition of R_{th} and Z_{th} measurements (PCB FR4 area= 60mm x 60mm, PCB thickness=2mm, Cu thickness=35 μ m, Copper areas: 6cm²).

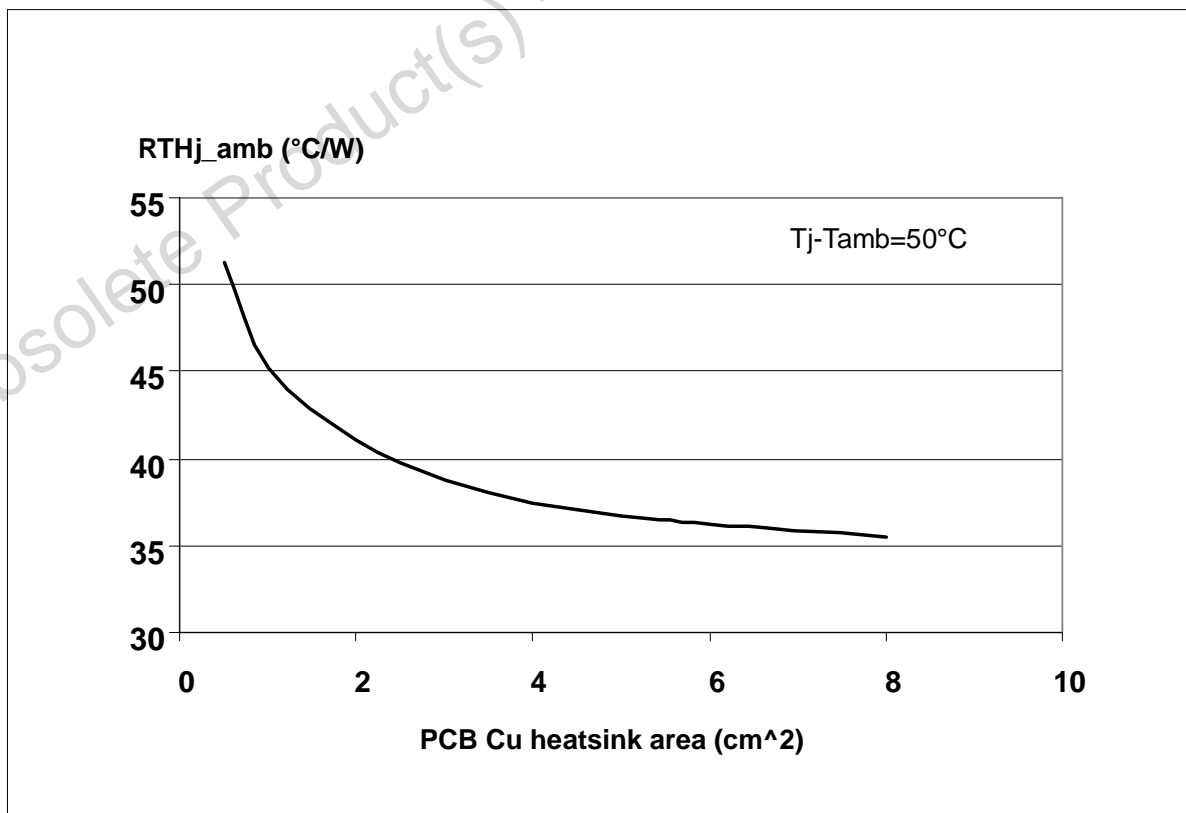
 $R_{thj-amb}$ Vs PCB copper area in open box free air condition

Thermal Impedance Junction Ambient Single Pulse

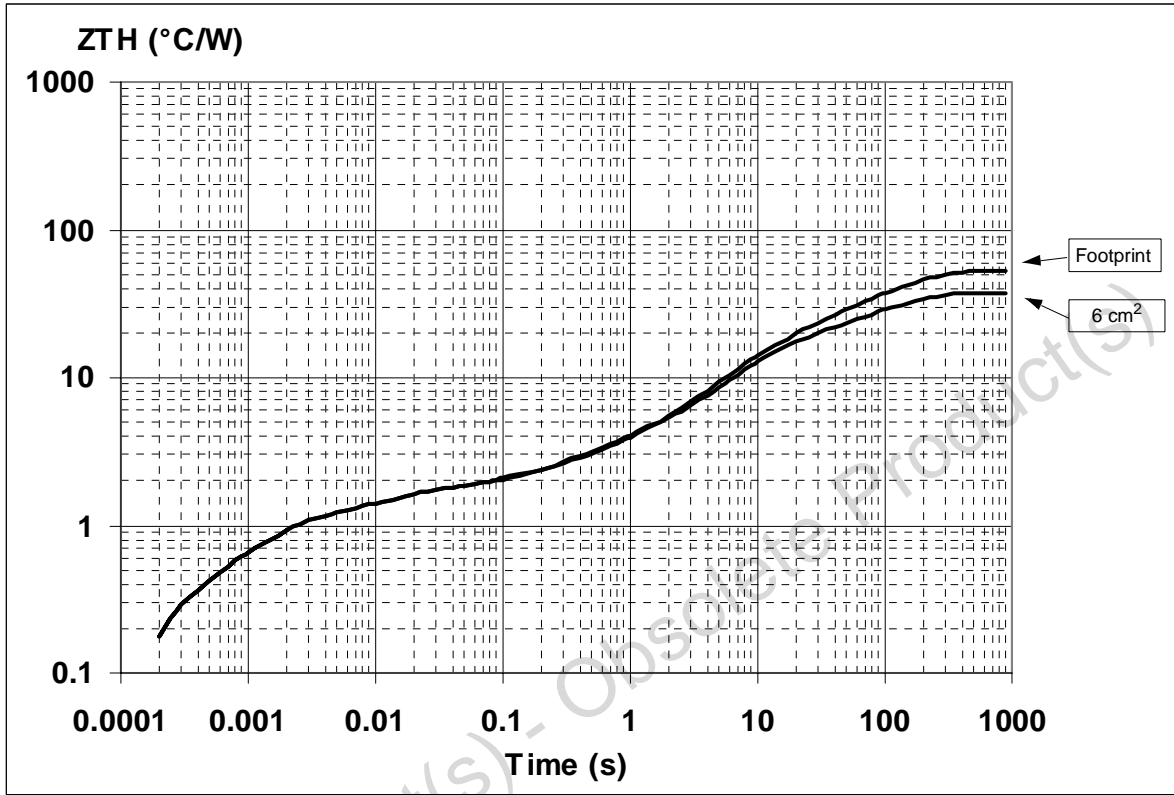

Thermal fitting model of a quad HSD in PowerSO-16

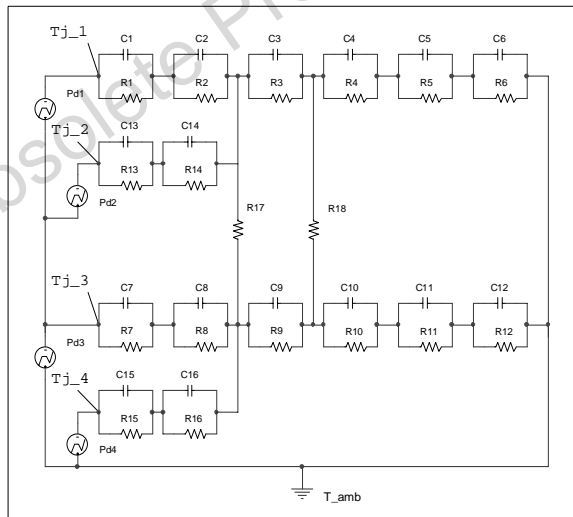

Pulse calculation formula

$$Z_{TH\delta} = R_{TH} \cdot \delta + Z_{THip}(1 - \delta)$$

where $\delta = t_p / T$

Thermal Parameter

Area/island (cm ²)	Footprint	6
R1 (°C/W)	0.18	
R2 (°C/W)	0.8	
R3 (°C/W)	0.7	
R4 (°C/W)	0.8	
R5 (°C/W)	13	
R6 (°C/W)	37	22
C1 (W.s/°C)	0.0006	
C2 (W.s/°C)	1.50E-03	
C3 (W.s/°C)	1.75E-02	
C4 (W.s/°C)	0.4	
C5 (W.s/°C)	0.75	
C6 (W.s/°C)	3	5

POWERSO-16™ MECHANICAL DATA

DIM.	mm.		
	MIN.	TYP	MAX.
A1	0	0.05	0.1
A2	3.4	3.5	3.6
A3	1.2	1.3	1.4
A4	0.15	0.2	0.25
a		0.2	
b	0.27	0.35	0.43
c	0.23	0.27	0.32
D	9.4	9.5	9.6
D1	7.4	7.5	7.6
d	0	0.05	0.1
E (1)	13.85	14.1	14.35
E1	9.3	9.4	9.5
E2	7.3	7.4	7.5
E3	5.9	6.1	6.3
e		0.8	
e1		5.6	
F		0.5	
G		1.2	
L	0.8	1	1.1
R1			0.25
R2		0.8	
T	2°	5°	8°
T1		6° (typ.)	
T2		10° (typ.)	
Package Weight		(typ.)	

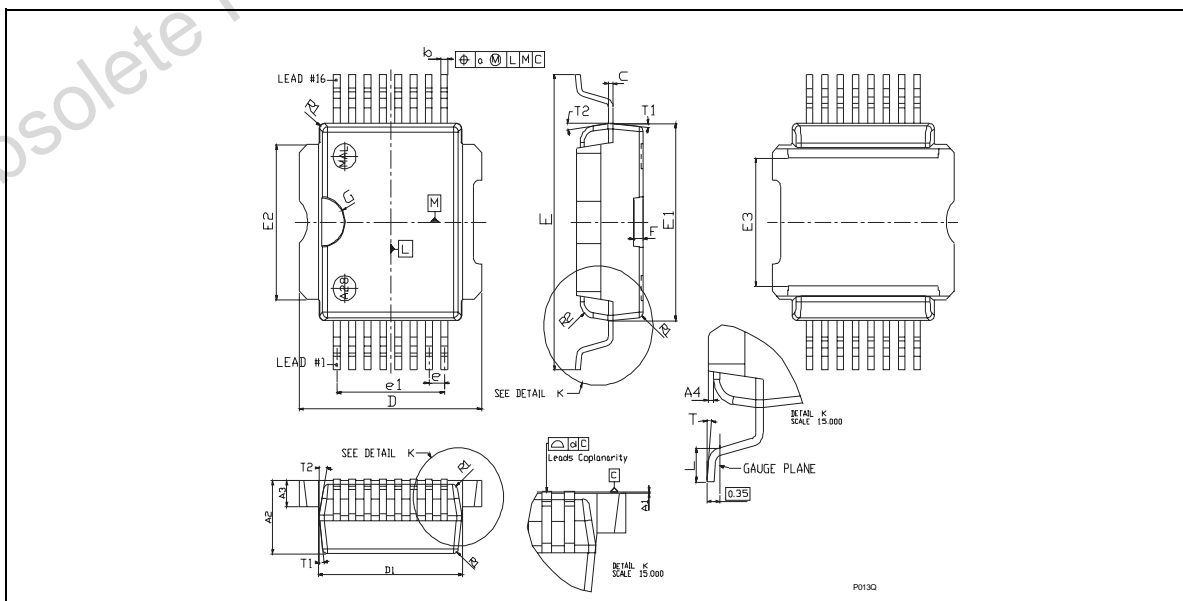

PowerSO-16™ SUGGESTED PAD LAYOUT

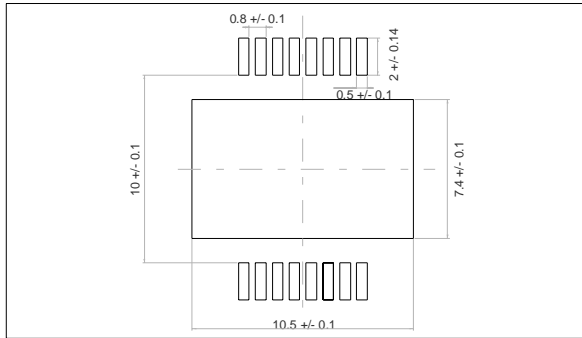

TUBE SHIPMENT (no suffix)

All dimensions are in mm.

Base Q.ty	Bulk Q.ty	Tube length (±0.5)	A	B	C (±0.1)
50	1000	532	4.9	17.2	0.8

TAPE AND REEL SHIPMENT (suffix "13TR")

REEL DIMENSIONS

Base Q.ty	600
Bulk Q.ty	600
A (max)	330
B (min)	1.5
C (±0.2)	13
F	20.2
G (+2 / -0)	24.4
N (min)	60
T (max)	30.4

All dimensions are in mm.

TAPE DIMENSIONS

According to Electronic Industries Association (EIA) Standard 481 rev. A, Feb. 1986

Tape width	W	24
Tape Hole Spacing	P0 (±0.1)	4
Component Spacing	P	24
Hole Diameter	D (±0.1/-0)	1.5
Hole Diameter	D1 (min)	1.5
Hole Position	F (±0.05)	11.5
Compartment Depth	K (max)	6.5
Hole Spacing	P1 (±0.1)	2

All dimensions are in mm.

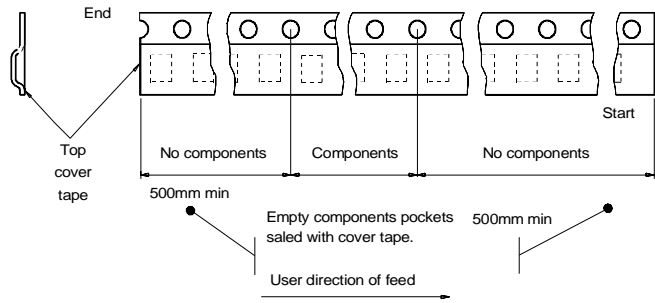
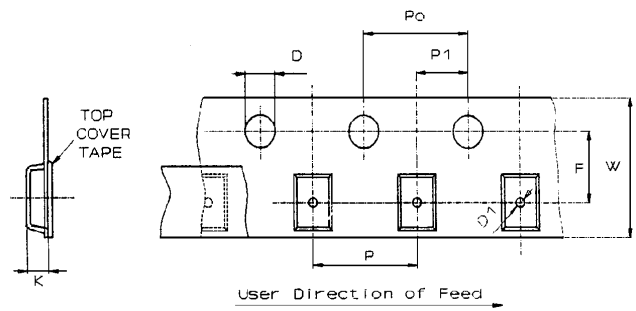
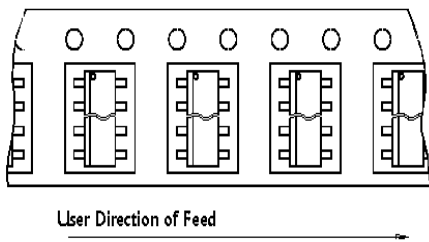

Please Read Carefully:

Information in this document is provided solely in connection with ST products. STMicroelectronics NV and its subsidiaries ("ST") reserve the right to make changes, corrections, modifications or improvements, to this document, and the products and services described herein at any time, without notice.

All ST products are sold pursuant to ST's terms and conditions of sale.

Purchasers are solely responsible for the choice, selection and use of the ST products and services described herein, and ST assumes no liability whatsoever relating to the choice, selection or use of the ST products and services described herein.

No license, express or implied, by estoppel or otherwise, to any intellectual property rights is granted under this document. If any part of this document refers to any third party products or services it shall not be deemed a license grant by ST for the use of such third party products or services, or any intellectual property contained therein or considered as a warranty covering the use in any manner whatsoever of such third party products or services or any intellectual property contained therein.

UNLESS OTHERWISE SET FORTH IN ST'S TERMS AND CONDITIONS OF SALE ST DISCLAIMS ANY EXPRESS OR IMPLIED WARRANTY WITH RESPECT TO THE USE AND/OR SALE OF ST PRODUCTS INCLUDING WITHOUT LIMITATION IMPLIED WARRANTIES OF MERCHANTABILITY, FITNESS FOR A PARTICULAR PURPOSE (AND THEIR EQUIVALENTS UNDER THE LAWS OF ANY JURISDICTION), OR INFRINGEMENT OF ANY PATENT, COPYRIGHT OR OTHER INTELLECTUAL PROPERTY RIGHT.

ST PRODUCTS ARE NOT DESIGNED OR AUTHORIZED FOR USE IN: (A) SAFETY CRITICAL APPLICATIONS SUCH AS LIFE SUPPORTING, ACTIVE IMPLANTED DEVICES OR SYSTEMS WITH PRODUCT FUNCTIONAL SAFETY REQUIREMENTS; (B) AERONAUTIC APPLICATIONS; (C) AUTOMOTIVE APPLICATIONS OR ENVIRONMENTS, AND/OR (D) AEROSPACE APPLICATIONS OR ENVIRONMENTS. WHERE ST PRODUCTS ARE NOT DESIGNED FOR SUCH USE, THE PURCHASER SHALL USE PRODUCTS AT PURCHASER'S SOLE RISK, EVEN IF ST HAS BEEN INFORMED IN WRITING OF SUCH USAGE, UNLESS A PRODUCT IS EXPRESSLY DESIGNATED BY ST AS BEING INTENDED FOR "AUTOMOTIVE, AUTOMOTIVE SAFETY OR MEDICAL" INDUSTRY DOMAINS ACCORDING TO ST PRODUCT DESIGN SPECIFICATIONS. PRODUCTS FORMALLY ESCC, QML OR JAN QUALIFIED ARE DEEMED SUITABLE FOR USE IN AEROSPACE BY THE CORRESPONDING GOVERNMENTAL AGENCY.

Resale of ST products with provisions different from the statements and/or technical features set forth in this document shall immediately void any warranty granted by ST for the ST product or service described herein and shall not create or extend in any manner whatsoever, any liability of ST.

ST and the ST logo are trademarks or registered trademarks of ST in various countries.

Information in this document supersedes and replaces all information previously supplied.

The ST logo is a registered trademark of STMicroelectronics. All other names are the property of their respective owners.

© 2013 STMicroelectronics - All rights reserved

STMicroelectronics group of companies



Australia - Belgium - Brazil - Canada - China - Czech Republic - Finland - France - Germany - Hong Kong - India - Israel - Italy - Japan - Malaysia - Malta - Morocco - Philippines - Singapore - Spain - Sweden - Switzerland - United Kingdom - United States of America

www.st.com



Looking for pricing, stock, or lifecycle information?

Click below to explore more details on WIN SOURCE:

-  [View VNQ05XSP16TR-E on WIN SOURCE](#)
-  [STMicroelectronics](#) Information

Optimize Your Supply Chain with WIN SOURCE Solutions

-  Global Sourcing Solution
-  Obsolete Management
-  Cost Control Management
-  Shortage Management
-  Alternative Solution
-  Excess Inventory Management