



THE DATASHEET OF VND5E025AKTR-E





VND5E025AK-E

Double channel high-side driver with analog current sense for automotive applications

Features

| | | |
|-----------------------------------|------------|--------------------------|
| Max transient supply voltage | V_{CC} | 41 V |
| Operating voltage range | V_{CC} | 4.5 to 28 V |
| Max on-state resistance (per ch.) | R_{ON} | 25 m Ω |
| Current limitation (typ) | I_{LIMH} | 60 A |
| Off-state supply current | I_S | 2 μ A ⁽¹⁾ |

1. Typical value with all loads connected.

- General
 - Inrush current active management by power limitation
 - Very low standby current
 - 3.0 V CMOS compatible inputs
 - Optimized electromagnetic emissions
 - Very low electromagnetic susceptibility
 - In compliance with the 2002/95/EC european directive
 - Very low current sense leakage
- Diagnostic functions
 - Proportional load current sense
 - High current sense precision for wide currents range
 - Current sense disable
 - Off-state open- load detection
 - Output short to V_{CC} detection
 - Overload and short to ground (power limitation) indication
 - Thermal shutdown indication
- Protections
 - Undervoltage shutdown
 - Overvoltage clamp
 - Load current limitation
 - Self limiting of fast thermal transients
 - Protection against loss of ground and loss of V_{CC}
 - Overtemperature shutdown with auto restart (thermal shutdown)



- Reverse battery protected
- Electrostatic discharge protection

Applications

- All types of resistive, inductive and capacitive loads
- Suitable as LED driver

Description

The VND5E025AK-E is a double channel high-side driver manufactured in the ST proprietary VIPower M0-5 technology and housed in the tiny PowerSSO-24 package. The VND5E025AK-E is designed to drive 12 V automotive grounded loads delivering protection, diagnostics and an easy 3 V and 5 V CMOS compatible interface with any microcontroller.

The device integrates advanced protective functions such as load current limitation, inrush and overload active management by power limitation, overtemperature shut-off with auto restart and overvoltage active clamp. A dedicated analog current sense pin is associated with every output channel in order to provide enhanced diagnostic functions including fast detection of overload and short-circuit to ground through power limitation indication, overtemperature indication, short-circuit to V_{CC} diagnosis and on-state and off-state open-load detection. The current sensing and diagnostic feedback of the whole device can be disabled by pulling the CS_DIS pin high to allow sharing of the external sense resistor with other similar devices.

Contents

| | | |
|----------|---|-----------|
| 1 | Block diagram and pin description | 5 |
| 2 | Electrical specifications | 7 |
| 2.1 | Absolute maximum ratings | 7 |
| 2.2 | Thermal data | 8 |
| 2.3 | Electrical characteristics | 8 |
| 2.4 | Waveforms | 19 |
| 2.5 | Electrical characteristics curves | 22 |
| 3 | Application information | 25 |
| 3.1 | GND protection network against reverse battery | 25 |
| 3.1.1 | Solution 1: resistor in the ground line (RGND only) | 25 |
| 3.1.2 | Solution 2: diode (DGND) in the ground line | 26 |
| 3.2 | Load dump protection | 26 |
| 3.3 | MCU I/Os protection | 26 |
| 3.4 | Current sense and diagnostic | 27 |
| 3.4.1 | Short to V_{CC} and off-state open-load detection | 28 |
| 3.5 | Maximum demagnetization energy ($V_{CC} = 13.5\text{ V}$) | 29 |
| 4 | Package and thermal data | 30 |
| 4.1 | PowerSSO-24 thermal data | 30 |
| 5 | Package and packing information | 33 |
| 5.1 | ECOPACK® packages | 33 |
| 5.2 | Package mechanical data | 33 |
| 5.3 | Packing information | 35 |
| 6 | Order codes | 36 |
| 7 | Revision history | 37 |

List of tables

| | | |
|-----------|---|----|
| Table 1. | Pin functions | 5 |
| Table 2. | Suggested connections for unused and not connected pins | 6 |
| Table 3. | Absolute maximum ratings | 7 |
| Table 4. | Thermal data | 8 |
| Table 5. | Power section | 8 |
| Table 6. | Switching ($V_{CC} = 13\text{ V}$; $T_j = 25\text{ °C}$) | 9 |
| Table 7. | Logic inputs | 10 |
| Table 8. | Protections and diagnostics | 10 |
| Table 9. | Current sense ($8\text{ V} < V_{CC} < 18\text{ V}$) | 11 |
| Table 10. | Open-load detection ($8\text{ V} < V_{CC} < 18\text{ V}$) | 12 |
| Table 11. | Truth table | 17 |
| Table 12. | Electrical transient requirements (part 1/3) | 18 |
| Table 13. | Electrical transient requirements (part 2/3) | 18 |
| Table 14. | Electrical transient requirements (part 3/3) | 18 |
| Table 15. | Thermal parameters | 32 |
| Table 16. | PowerSSO-24™ mechanical data | 34 |
| Table 17. | Device summary | 36 |
| Table 18. | Document revision history | 37 |

List of figures

| | | |
|------------|---|----|
| Figure 1. | Block diagram | 5 |
| Figure 2. | Configuration diagram (top view) | 6 |
| Figure 3. | Current and voltage conventions | 7 |
| Figure 4. | Current sense delay characteristics | 13 |
| Figure 5. | Openload off-state delay timing | 13 |
| Figure 6. | Switching characteristics | 14 |
| Figure 7. | Delay response time between rising edge of output current and rising edge of current sense (CS enabled) | 15 |
| Figure 8. | Output voltage drop limitation | 15 |
| Figure 9. | I_{OUT}/I_{SENSE} vs I_{OUT} | 16 |
| Figure 10. | Maximum current sense ratio drift vs load current | 16 |
| Figure 11. | Normal operation | 19 |
| Figure 12. | Overload or short to GND | 19 |
| Figure 13. | Intermittent overload | 20 |
| Figure 14. | Off-state open-load with external circuitry | 20 |
| Figure 15. | Short to V_{CC} | 21 |
| Figure 16. | T_J evolution in overload or short to GND | 21 |
| Figure 17. | Off-state output current | 22 |
| Figure 18. | High level input current | 22 |
| Figure 19. | Input clamp voltage | 22 |
| Figure 20. | Input high level voltage | 22 |
| Figure 21. | Input low level voltage | 22 |
| Figure 22. | Input hysteresis voltage | 22 |
| Figure 23. | On-state resistance vs T_{case} | 23 |
| Figure 24. | On-state resistance vs V_{CC} | 23 |
| Figure 25. | Undervoltage shutdown | 23 |
| Figure 26. | I_{LIMH} vs T_{case} | 23 |
| Figure 27. | Turn-on voltage slope | 23 |
| Figure 28. | Turn-off voltage slope | 23 |
| Figure 29. | CS_DIS high level voltage | 24 |
| Figure 30. | CS_DIS low level voltage | 24 |
| Figure 31. | CS_DIS clamp voltage | 24 |
| Figure 32. | Application schematic ⁽¹⁾ | 25 |
| Figure 33. | Current sense and diagnostic | 27 |
| Figure 34. | Maximum turn-off current versus inductance (for each channel) ⁽¹⁾ | 29 |
| Figure 35. | PowerSSO-24 PC board ⁽¹⁾ | 30 |
| Figure 36. | $R_{thj-amb}$ vs PCB copper area in open box free air condition (one channel on) | 30 |
| Figure 37. | PowerSSO-24 thermal impedance junction to ambient single pulse (one channel on) | 31 |
| Figure 38. | Thermal fitting model of a double channel HSD in PowerSSO-24 ⁽¹⁾ | 31 |
| Figure 39. | PowerSSO-24 package dimensions | 33 |
| Figure 40. | PowerSSO-24 tube shipment (no suffix) | 35 |
| Figure 41. | PowerSSO-24 tape and reel shipment (suffix "TR") | 35 |

1 Block diagram and pin description

Figure 1. Block diagram

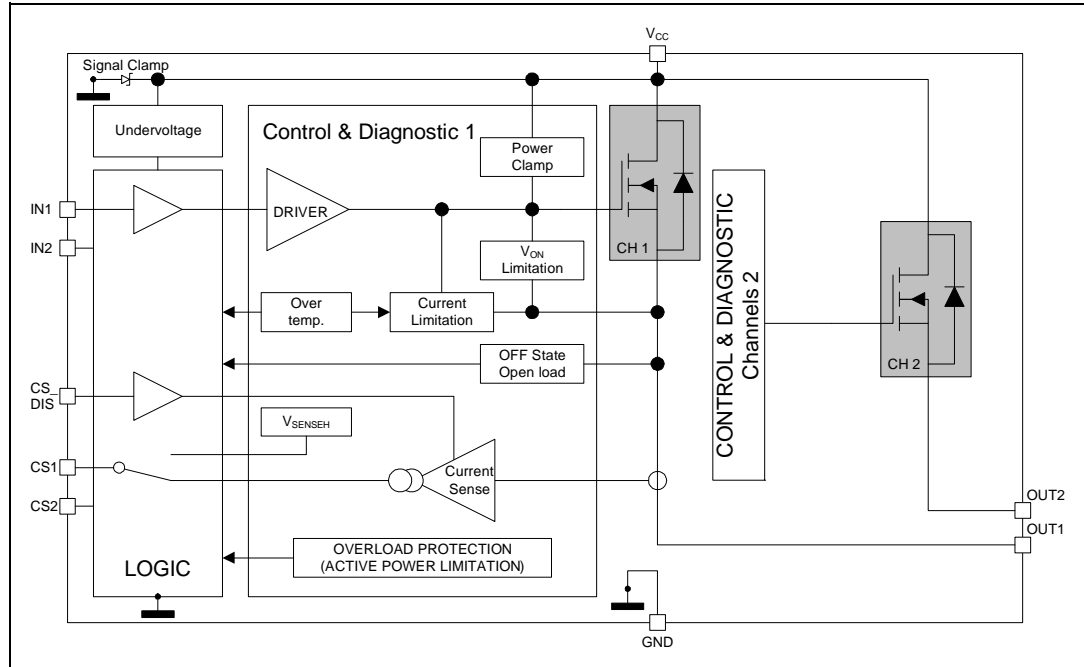

Table 1. Pin functions

| Name | Function |
|------------------------------|---|
| V _{CC} | Battery connection. |
| OUTPUT _{1,2} | Power output. |
| GND | Ground connection. Must be reverse battery protected by an external diode / resistor network. |
| INPUT _{1,2} | Voltage controlled input pin with hysteresis, CMOS compatible. Controls output switch state. |
| CURRENT SENSE _{1,2} | Analog current sense pin; delivers a current proportional to the load current. |
| CS_DIS | Active high CMOS compatible pin to disable the current sense pin. |

Figure 2. Configuration diagram (top view)

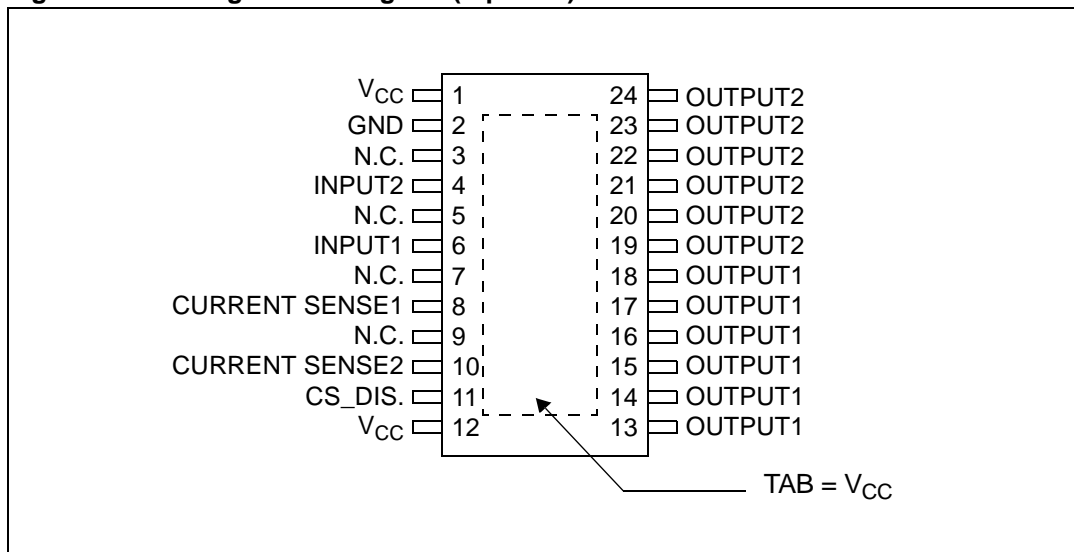
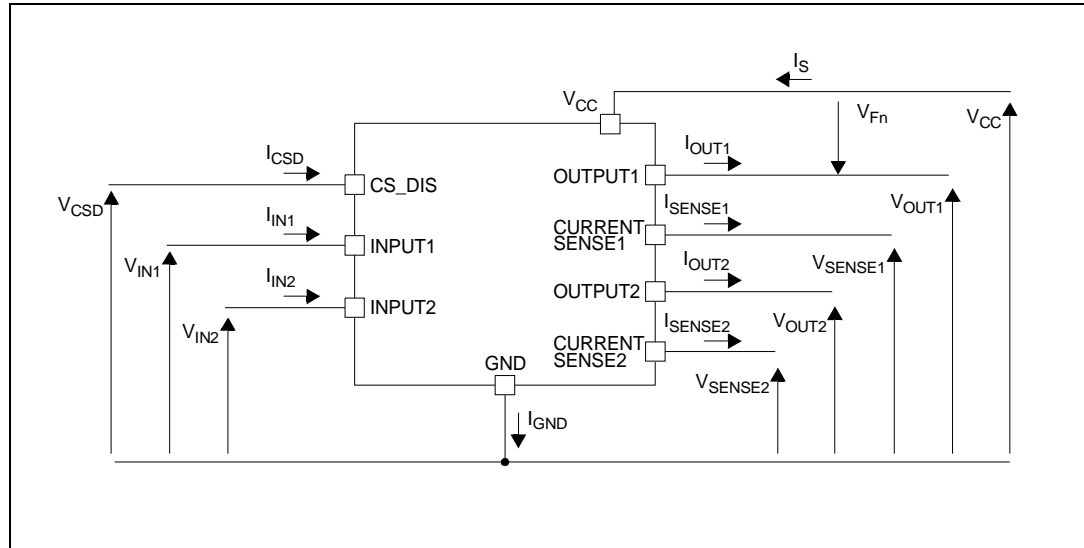

Table 2. Suggested connections for unused and not connected pins

| Connection / pin | Current sense | N.C. | Output | Input | CS_DIS |
|------------------|----------------------|------|-----------------------|-----------------------|-----------------------|
| Floating | Not allowed | X | X | X | X |
| To ground | Through 1kΩ resistor | X | Through 22kΩ resistor | Through 10kΩ resistor | Through 10kΩ resistor |

2 Electrical specifications

Figure 3. Current and voltage conventions



Note: $V_{Fn} = V_{OUTn} - V_{CC}$ during reverse battery condition.

2.1 Absolute maximum ratings

Stressing the device above the rating listed in the “Absolute maximum ratings” table may cause permanent damage to the device. These are stress ratings only and operation of the device at these or any other conditions above those indicated in the Operating sections of this specification is not implied. Exposure to the conditions in table below for extended periods may affect device reliability. Refer also to the STMicroelectronics SURE Program and other relevant quality document.

Table 3. Absolute maximum ratings

| Symbol | Parameter | Value | Unit |
|---------------|--|----------------------------|------|
| V_{CC} | DC supply voltage | 41 | V |
| $-V_{CC}$ | Reverse DC supply voltage | 0.3 | |
| $-I_{GND}$ | DC reverse ground pin current | 200 | mA |
| I_{OUT} | DC output current | Internally limited | A |
| $-I_{OUT}$ | Reverse DC output current | 24 | |
| I_{IN} | DC input current | -1 to 10 | mA |
| I_{CSD} | DC current sense disable input current | | |
| $-I_{CSENSE}$ | DC reverse CS pin current | 200 | |
| V_{CSENSE} | Current sense maximum voltage | $V_{CC} - 41$ to $+V_{CC}$ | V |

Table 3. Absolute maximum ratings (continued)

| Symbol | Parameter | Value | Unit |
|-----------|---|-------------|------------------|
| E_{MAX} | Maximum switching energy (single pulse) ($L = 0.8 \text{ mH}$; $R_L = 0 \text{ }\Omega$; $V_{bat} = 13.5 \text{ V}$; $T_{jstart} = 150 \text{ }^\circ\text{C}$; $I_{OUT} = I_{limL}(Typ.)$) | 140 | mJ |
| V_{ESD} | Electrostatic discharge (Human Body Model: $R = 1.5 \text{ k}\Omega$; $C = 100 \text{ pF}$) | | |
| | – Input | 4000 | V |
| | – Current sense | 2000 | V |
| | – CS_DIS | 4000 | V |
| | – Output | 5000 | V |
| | – V_{CC} | 5000 | V |
| V_{ESD} | Charge device model (CDM-AEC-Q100-011) | 750 | V |
| T_j | Junction operating temperature | - 40 to 150 | $^\circ\text{C}$ |
| T_{stg} | Storage temperature | - 55 to 150 | |

2.2 Thermal data

Table 4. Thermal data

| Symbol | Parameter | Max value | Unit |
|----------------|--|-------------------------------|---------------------------|
| $R_{thj-case}$ | Thermal resistance junction-case (with one channel ON) | 1.35 | $^\circ\text{C}/\text{W}$ |
| $R_{thj-amb}$ | Thermal resistance junction-ambient | See Figure 36 | |

2.3 Electrical characteristics

Values specified in this section are for $8 \text{ V} < V_{CC} < 28 \text{ V}$; $-40 \text{ }^\circ\text{C} < T_j < 150 \text{ }^\circ\text{C}$, unless otherwise stated.

Table 5. Power section

| Symbol | Parameter | Test conditions | Min. | Typ. | Max. | Unit |
|---------------|------------------------------------|--|------|------|------|------------|
| V_{CC} | Operating supply voltage | | 4.5 | 13 | 28 | V |
| V_{USD} | Undervoltage shutdown | | | 3.5 | 4.5 | |
| $V_{USDhyst}$ | Undervoltage shutdown hysteresis | | | 0.5 | | |
| R_{ON} | On-state resistance ⁽¹⁾ | $I_{OUT} = 3 \text{ A}$; $T_j = 25 \text{ }^\circ\text{C}$ | | | 25 | m Ω |
| | | $I_{OUT} = 3 \text{ A}$; $T_j = 150 \text{ }^\circ\text{C}$ | | | 50 | |
| | | $I_{OUT} = 3 \text{ A}$; $V_{CC} = 5 \text{ V}$; $T_j = 25 \text{ }^\circ\text{C}$ | | | 35 | |
| V_{clamp} | Clamp voltage | $I_S = 20 \text{ mA}$ | 41 | 46 | 52 | V |

Table 5. Power section (continued)

| Symbol | Parameter | Test conditions | Min. | Typ. | Max. | Unit |
|---------------|-------------------------------------|---|------|-------|-------|---------------|
| I_S | Supply current | Off-state; $V_{CC} = 13\text{ V}$; $T_j = 25\text{ °C}$; $V_{IN} = V_{OUT} = V_{SENSE} = V_{CSD} = 0\text{ V}$ | | 2 (2) | 5 (2) | μA |
| | | On-state; $V_{CC} = 13\text{ V}$; $V_{IN} = 5\text{ V}$; $I_{OUT} = 0\text{ A}$ | | 3 | 6 | mA |
| $I_{L(off1)}$ | Off-state output current (1) | $V_{IN} = V_{OUT} = 0\text{ V}$; $V_{CC} = 13\text{ V}$; $T_j = 25\text{ °C}$ | 0 | 0.01 | 3 | μA |
| | | $V_{IN} = V_{OUT} = 0\text{ V}$; $V_{CC} = 13\text{ V}$; $T_j = 125\text{ °C}$ | 0 | | 5 | |
| V_F | Output - V_{CC} diode voltage (1) | $-I_{OUT} = 4\text{ A}$; $T_j = 150\text{ °C}$ | | | 0.7 | V |

1. For each channel.

2. PowerMOS leakage included.

Table 6. Switching ($V_{CC} = 13\text{ V}$; $T_j = 25\text{ °C}$)

| Symbol | Parameter | Test conditions | Min. | Typ. | Max. | Unit |
|-----------------------|---|--|------|-------------------------------|------|------------------------|
| $t_{d(on)}$ | Turn-On delay time | $R_L = 4.3\ \Omega$ (see Figure 6) | | 20 | | μs |
| $t_{d(off)}$ | Turn-Off delay time | | | 40 | | |
| $(dV_{OUT}/dt)_{on}$ | Turn-On voltage slope | $R_L = 4.3\ \Omega$ | | See Figure 27 | | $\text{V}/\mu\text{s}$ |
| $(dV_{OUT}/dt)_{off}$ | Turn-Off voltage slope | | | See Figure 28 | | |
| W_{ON} | Switching energy losses during t_{WON} | $R_L = 4.3\ \Omega$ (see Figure 6) | | 0.6 | | mJ |
| W_{OFF} | Switching energy losses during t_{WOFF} | | | 0.35 | | |

Table 7. Logic inputs

| Symbol | Parameter | Test conditions | Min. | Typ. | Max. | Unit |
|-----------------|---------------------------|--------------------------|------|------|------|---------------|
| V_{IL} | Input low level voltage | | | | 0.9 | V |
| I_{IL} | Low level input current | $V_{IN} = 0.9\text{ V}$ | 1 | | | μA |
| V_{IH} | Input high level voltage | | 2.1 | | | V |
| I_{IH} | High level input current | $V_{IN} = 2.1\text{ V}$ | | | 10 | μA |
| $V_{I(hyst)}$ | Input hysteresis voltage | | 0.25 | | | V |
| V_{ICL} | Input clamp voltage | $I_{IN} = 1\text{ mA}$ | 5.5 | | 7 | |
| | | $I_{IN} = -1\text{ mA}$ | | -0.7 | | |
| V_{CSDL} | CS_DIS low level voltage | | | | 0.9 | μA |
| I_{CSDL} | Low level CS_DIS current | $V_{CSD} = 0.9\text{ V}$ | 1 | | | |
| V_{CSDH} | CS_DIS high level voltage | | 2.1 | | | V |
| I_{CSDH} | High level CS_DIS current | $V_{CSD} = 2.1\text{ V}$ | | | 10 | μA |
| $V_{CSD(hyst)}$ | CS_DIS hysteresis voltage | | 0.25 | | | V |
| V_{CSCL} | CS_DIS clamp voltage | $I_{CSD} = 1\text{ mA}$ | 5.5 | | 7 | |
| | | $I_{CSD} = -1\text{ mA}$ | | -0.7 | | |

Table 8. Protections and diagnostics (1)

| Symbol | Parameter | Test conditions | Min. | Typ. | Max. | Unit |
|-------------|--|--|---------------|---------------|---------------|------|
| I_{LIMH} | DC short circuit current | $V_{CC} = 13\text{ V}$ | 43 | 60 | 85 | A |
| | | $5\text{ V} < V_{CC} < 28\text{ V}$ | | | | |
| I_{LIML} | Short circuit current during thermal cycling | $V_{CC} = 13\text{ V};$ $T_R < T_j < T_{TSD}$ | | 15 | | |
| T_{TSD} | Shutdown temperature | | 150 | 175 | 200 | °C |
| T_R | Reset temperature | | $T_{RS} + 1$ | $T_{RS} + 5$ | | |
| T_{RS} | Thermal reset of STATUS | | 135 | | | |
| T_{HYST} | Thermal hysteresis ($T_{TSD} - T_R$) | | | 7 | | |
| V_{DEMAG} | Turn-Off output voltage clamp | $I_{OUT} = 2\text{ A}; V_{IN} = 0;$ $L = 6\text{ mH}$ | $V_{CC} - 41$ | $V_{CC} - 46$ | $V_{CC} - 52$ | V |
| V_{ON} | Output voltage drop limitation | $I_{OUT} = 0.1\text{ A};$ $T_j = -40\text{ °C to } +150\text{ °C}$ (see Figure 8) | | 25 | | mV |

1. To ensure long term reliability under heavy overload or short circuit conditions, protection and related diagnostic signals must be used together with a proper software strategy. If the device is subjected to abnormal conditions, this software must limit the duration and number of activation cycles.

Table 9. Current sense (8 V < V_{CC} < 18 V)

| Symbol | Parameter | Test conditions | Min. | Typ. | Max. | Unit |
|--|---|---|------|------|------|------|
| K _{LED} | I _{OUT} /I _{SENSE} | I _{OUT} = 0.05 A; V _{SENSE} = 0.5 V; V _{CSD} = 0 V; T _j = -40 °C to 150 °C | 1240 | 3350 | 4960 | |
| K ₀ | I _{OUT} /I _{SENSE} | I _{OUT} = 0.5 A; V _{SENSE} = 0.5 V; V _{CSD} = 0 V; T _j = -40 °C to 150 °C | 1860 | 3150 | 4600 | |
| K ₁ | I _{OUT} /I _{SENSE} | I _{OUT} = 2 A; V _{SENSE} = 4 V; V _{CSD} = 0 V; T _j = -40 °C to 150 °C T _j = 25 °C to 150 °C | 2100 | 3100 | 4400 | |
| | | | 2250 | 3100 | 3850 | |
| dK ₁ /K ₁ ⁽¹⁾ | Current sense ratio drift | I _{OUT} = 2 A; V _{SENSE} = 4 V; V _{CSD} = 0 V; T _j = -40 °C to 150 °C | -13 | | 13 | % |
| K ₂ | I _{OUT} /I _{SENSE} | I _{OUT} = 3 A; V _{SENSE} = 4 V; V _{CSD} = 0 V; T _j = -40 °C to 150 °C T _j = 25 °C to 150 °C | 2200 | 3000 | 4100 | |
| | | | 2450 | 3000 | 3550 | |
| dK ₂ /K ₂ ⁽¹⁾ | Current sense ratio drift | I _{OUT} = 3 A; V _{SENSE} = 4 V; V _{CSD} = 0 V; T _j = -40 °C to 150 °C | -12 | | 12 | % |
| K ₃ | I _{OUT} /I _{SENSE} | I _{OUT} = 10 A; V _{SENSE} = 4V; V _{CSD} = 0V; T _j = -40°C to 150°C T _j = 25°C to 150°C | 2550 | 2850 | 3280 | |
| | | | 2650 | 2850 | 3180 | |
| dK ₃ /K ₃ ⁽¹⁾ | Current sense ratio drift | I _{OUT} = 10 A; V _{SENSE} = 4V; V _{CSD} = 0V; T _j = -40°C to 150°C | -6 | | +6 | % |
| I _{SENSE0} | Analog sense leakage current | I _{OUT} = 0 A; V _{SENSE} = 0 V; V _{CSD} = 5 V; V _{IN} = 0V; T _j = -40°C to 150°C | 0 | | 1 | μA |
| | | V _{CSD} = 0 V; V _{IN} = 5 V; T _j = -40 °C to 150 °C | 0 | | 2 | μA |
| | | I _{OUT} = 2A; V _{SENSE} = 0V; V _{CSD} = 5V; V _{IN} = 5V; T _j = -40°C to 150°C | 0 | | 1 | μA |
| I _{OL} | Open-load on-state current detection threshold | V _{IN} = 5 V, 8 V < V _{CC} < 18 V I _{SENSE} = 5 μA | 5 | | 30 | mA |
| V _{SENSE} | Max analog sense output voltage | I _{OUT} = 3 A; V _{CSD} = 0 V | 5 | | | V |
| V _{SENSEH} | Analog sense output voltage in fault condition ⁽¹⁾ | V _{CC} = 13 V; R _{SENSE} = 3.9 kΩ | | 8 | | |

Table 9. Current sense (8 V < V_{CC} < 18 V) (continued)

| Symbol | Parameter | Test conditions | Min. | Typ. | Max. | Unit |
|------------------------|--|--|------|------|------|------|
| I _{SENSEH} | Analog sense output current in fault condition ⁽²⁾ | V _{CC} = 13 V; V _{SENSE} = 5 V | | 9 | | mA |
| t _{DSENSE1H} | Delay response time from falling edge of CS_DIS pin | V _{SENSE} < 4 V, 0.5 < I _{OUT} < 10 A I _{SENSE} = 90% of I _{SENSEMAX} (see Figure 4) | | 30 | 100 | μs |
| t _{DSENSE1L} | Delay response time from rising edge of CS_DIS pin | V _{SENSE} < 4 V, 0.5 < I _{OUT} < 10 A I _{SENSE} = 10 % of I _{SENSEMAX} (see Figure 4) | | 5 | 20 | |
| t _{DSENSE2H} | Delay response time from rising edge of INPUT pin | V _{SENSE} < 4 V, 0.5 < I _{OUT} < 10 A I _{SENSE} = 90% of I _{SENSEMAX} (see Figure 4) | | 80 | 300 | |
| Δt _{DSENSE2H} | Delay response time between rising edge of output current and rising edge of current sense | V _{SENSE} < 4 V, I _{SENSE} = 90 % of I _{SENSEMAX} , I _{OUT} = 90 % of I _{OUTMAX} , I _{OUTMAX} = 3 A (see Figure 7) | | | 110 | |
| t _{DSENSE2L} | Delay response time from falling edge of INPUT pin | V _{SENSE} < 4 V, 0.5 < I _{OUT} < 10 A I _{SENSE} = 10 % of I _{SENSEMAX} (see Figure 4) | | 70 | 250 | |

1. Fault condition includes: power limitation, overtemperature and open-load off-state detection.

Table 10. Open-load detection (8 V < V_{CC} < 18 V)

| Symbol | Parameter | Test condition | Min. | Typ. | Max. | Unit |
|-----------------------|---|--|------|------------------------------|------|------|
| V _{OL} | Open-load off-state voltage detection threshold | V _{IN} = 0 V | 2 | See Figure 5 | 4 | V |
| t _{DSTKON} | Output short circuit to V _{CC} detection delay at turn-off | See Figure 5 | 180 | | 1200 | μs |
| I _{L(off2)r} | Off-state output current at V _{OUT} = 4V | V _{IN} = 0 V; V _{SENSE} = 0 V V _{OUT} rising from 0 V to 4 V | -120 | | 0 | μA |

Table 10. Open-load detection (8 V < V_{CC} < 18 V) (continued)

| Symbol | Parameter | Test condition | Min. | Typ. | Max. | Unit |
|----------------|---|---|------|------|------|---------------|
| $I_{L(off)2f}$ | Off-state output current at $V_{OUT} = 2\text{ V}$ | $V_{IN} = 0\text{ V}$; $V_{SENSE} = V_{SENSEH}$ V_{OUT} falling from V_{CC} to 2 V | -50 | | 90 | μA |
| t_{d_vol} | Delay response from output rising edge to V_{SENSE} rising edge in openload | $V_{OUT} = 4\text{ V}$; $V_{IN} = 0\text{ V}$ $V_{SENSE} = 90\% \text{ of } V_{SENSEH}$ | | | 20 | μs |

Figure 4. Current sense delay characteristics

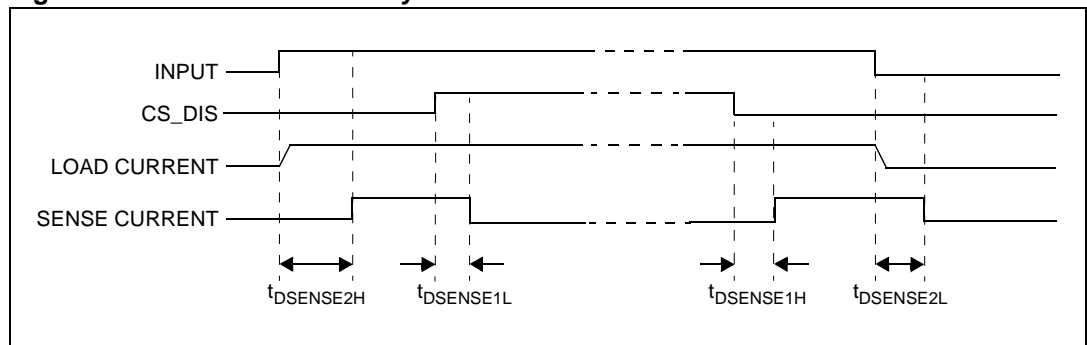

Figure 5. Openload off-state delay timing

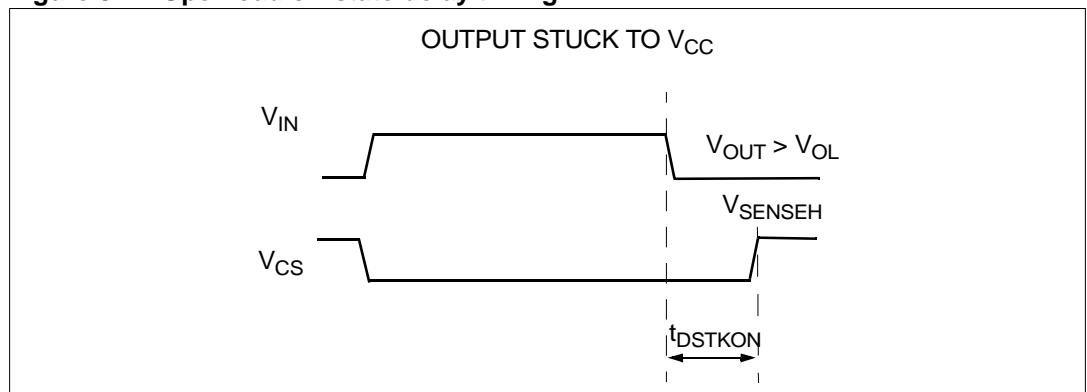

Figure 6. Switching characteristics

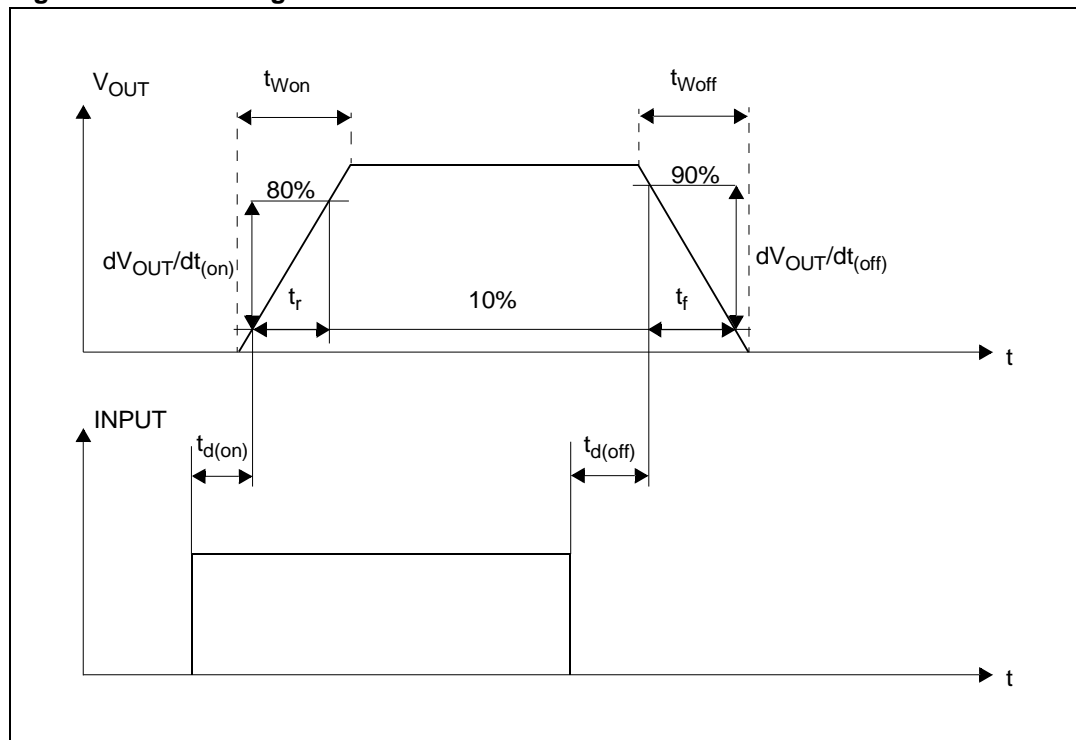

Figure 7. Delay response time between rising edge of output current and rising edge of current sense (CS enabled)

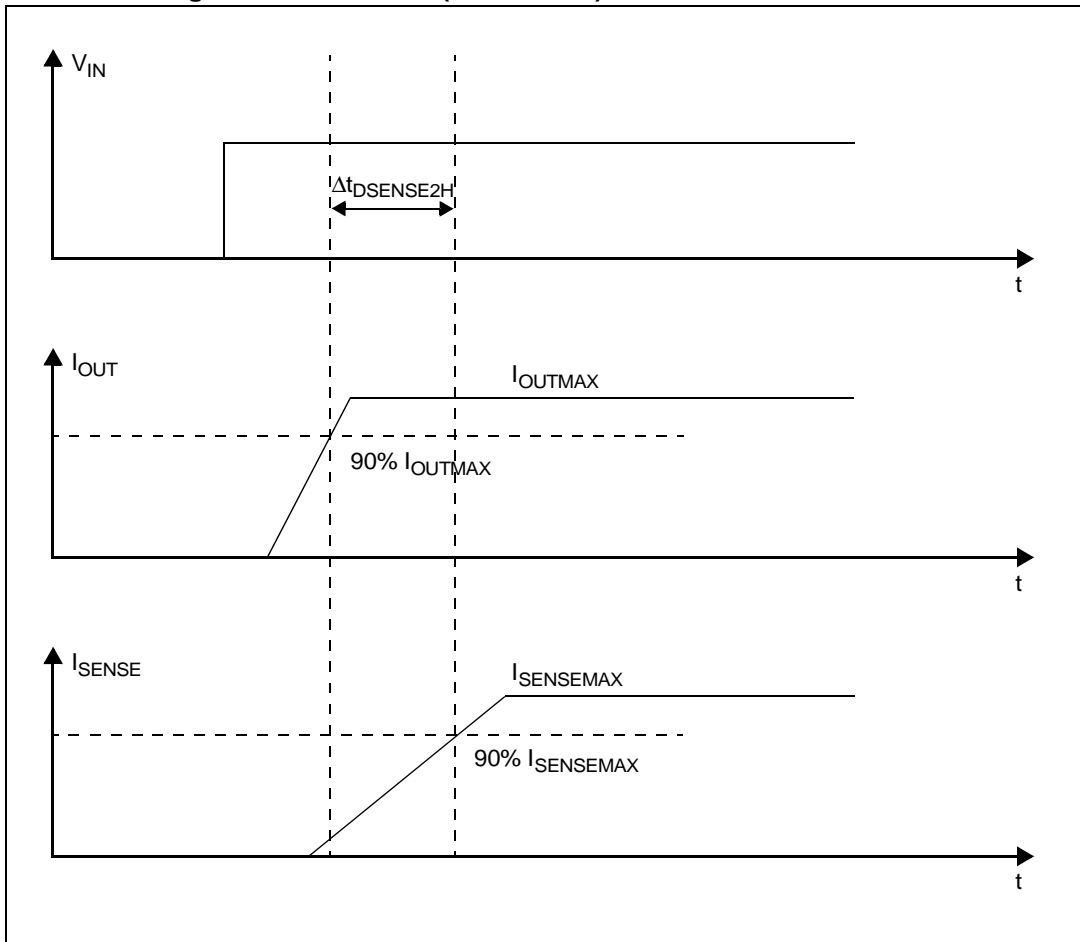

Figure 8. Output voltage drop limitation

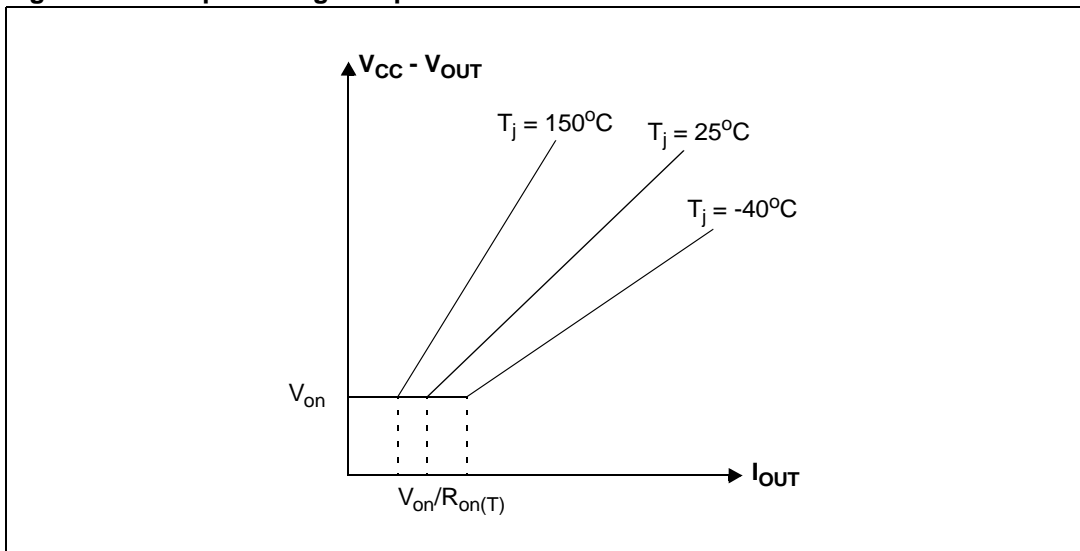

Figure 9. I_{OUT}/I_{SENSE} vs I_{OUT}

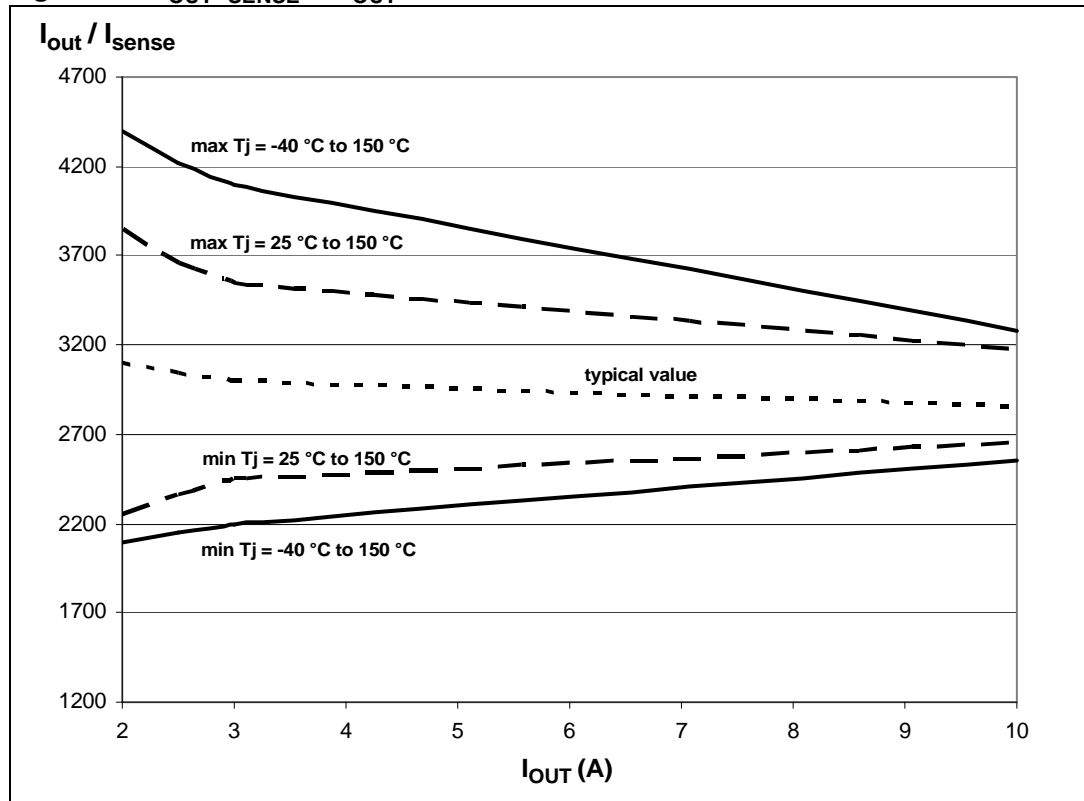
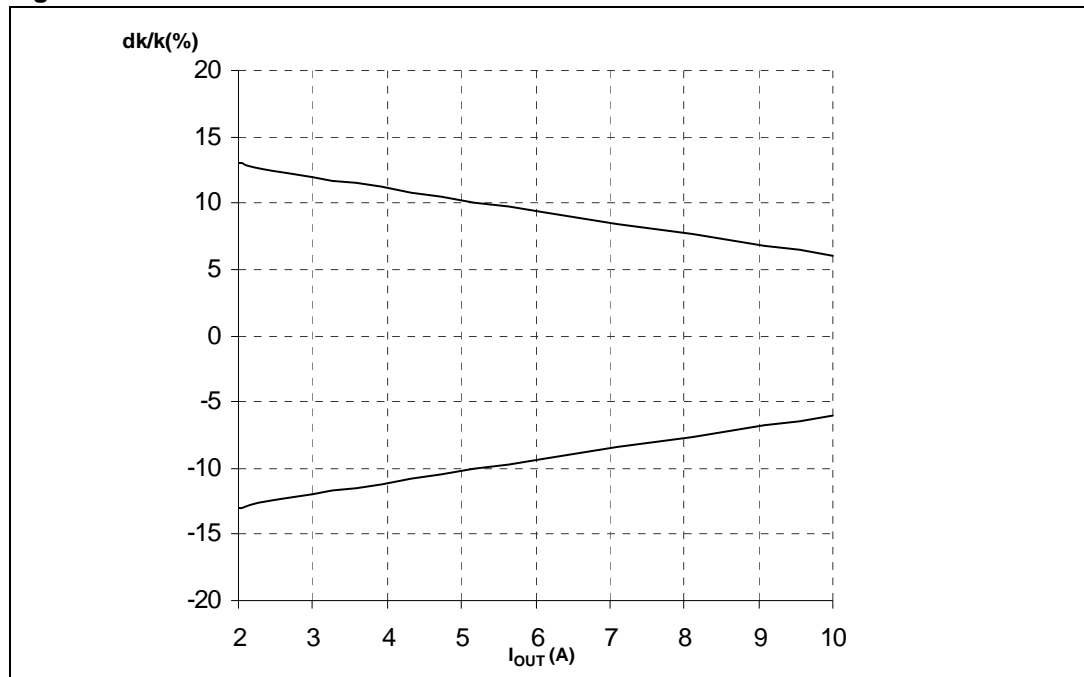

Figure 10. Maximum current sense ratio drift vs load current



Note: Parameter guaranteed by design; it is not tested.

Table 11. Truth table

| Conditions | Input | Output | Sense ($V_{CSD} = 0\text{ V}$) ⁽¹⁾ |
|---|-------|-------------------------------|---|
| Normal operation | L | L | 0 |
| | H | H | Nominal |
| Overtemperature | L | L | 0 |
| | H | L | V_{SENSEH} |
| Undervoltage | L | L | 0 |
| | H | L | 0 |
| Overload | H | X (no power limitation) | Nominal |
| | H | Cycling (power limitation) | V_{SENSEH} |
| Short circuit to GND (Power limitation) | L | L | 0 |
| | H | L | V_{SENSEH} |
| Open-load off-state (with external pull up) | L | H | V_{SENSEH} |
| Short circuit to V_{CC} (external pull up disconnected) | L | H | V_{SENSEH} |
| | H | H | V_{SENSEH} < Nominal |
| Negative output voltage clamp | L | L | 0 |

1. If the V_{CSD} is high, the SENSE output is at a high impedance, its potential depends on leakage currents and external circuit.

Table 12. Electrical transient requirements (part 1/3)

| ISO 7637-2: 2004(E) Test pulse | Test levels ⁽¹⁾ | | Number of pulses or test times | Burst cycle / pulse repetition time | | Delays and Impedance |
|--------------------------------------|----------------------------|-------|--------------------------------------|--|-------|-------------------------|
| | III | IV | | Min. | Max. | |
| 1 | -75V | -100V | 5000 pulses | 0.5s | 5s | 2 ms, 10Ω |
| 2a | +37V | +50V | 5000 pulses | 0.2s | 5s | 50μs, 2Ω |
| 3a | -100V | -150V | 1h | 90ms | 100ms | 0.1μs, 50Ω |
| 3b | +75V | +100V | 1h | 90ms | 100ms | 0.1μs, 50Ω |
| 4 | -6V | -7V | 1 pulse | | | 100ms, 0.01Ω |
| 5b ⁽²⁾ | +65V | +87V | 1 pulse | | | 400ms, 2Ω |

1. The above test levels must be considered referred to $V_{CC} = 13.5V$ except for pulse 5b.
2. Valid in case of external load dump clamp: 40V maximum referred to ground.

Table 13. Electrical transient requirements (part 2/3)

| ISO 7637-2: 2004E Test pulse | Test level results | |
|------------------------------------|--------------------|----|
| | III | VI |
| 1 | C | C |
| 2a | C | C |
| 3a | C | C |
| 3b | C | C |
| 4 | C | C |
| 5b ⁽¹⁾ | C | C |

1. Valid in case of external load dump clamp: 40V maximum referred to ground

Table 14. Electrical transient requirements (part 3/3)

| Class | Contents |
|-------|--|
| C | All functions of the device performed as designed after exposure to disturbance. |
| E | One or more functions of the device did not perform as designed after exposure to disturbance and cannot be returned to proper operation without replacing the device. |

2.4 Waveforms

Figure 11. Normal operation

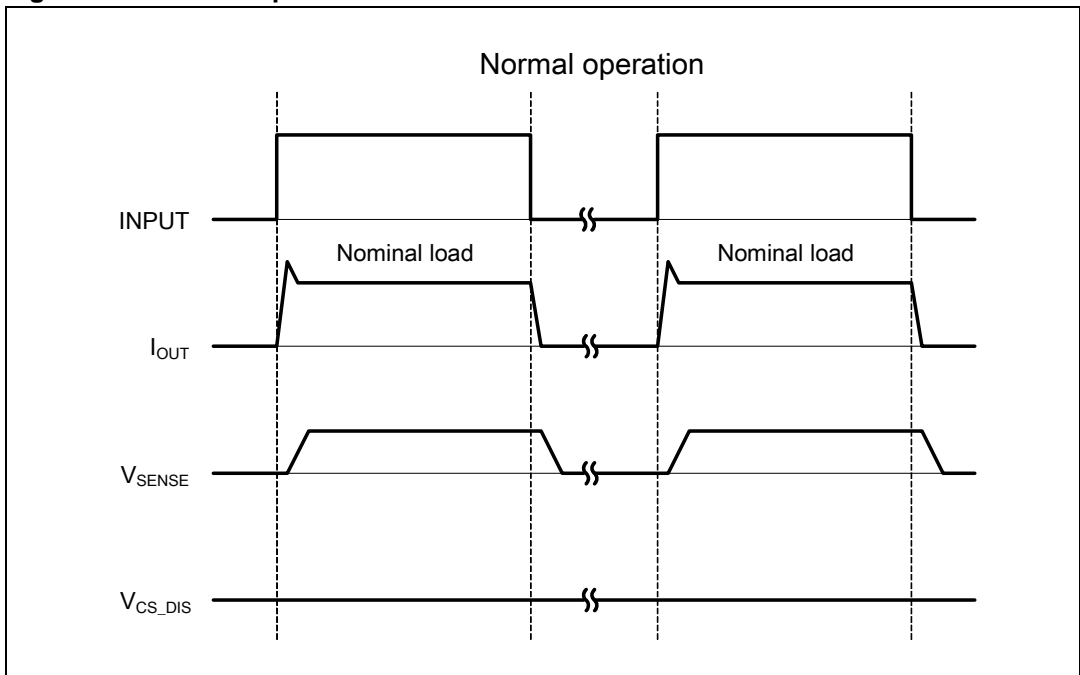

Figure 12. Overload or short to GND

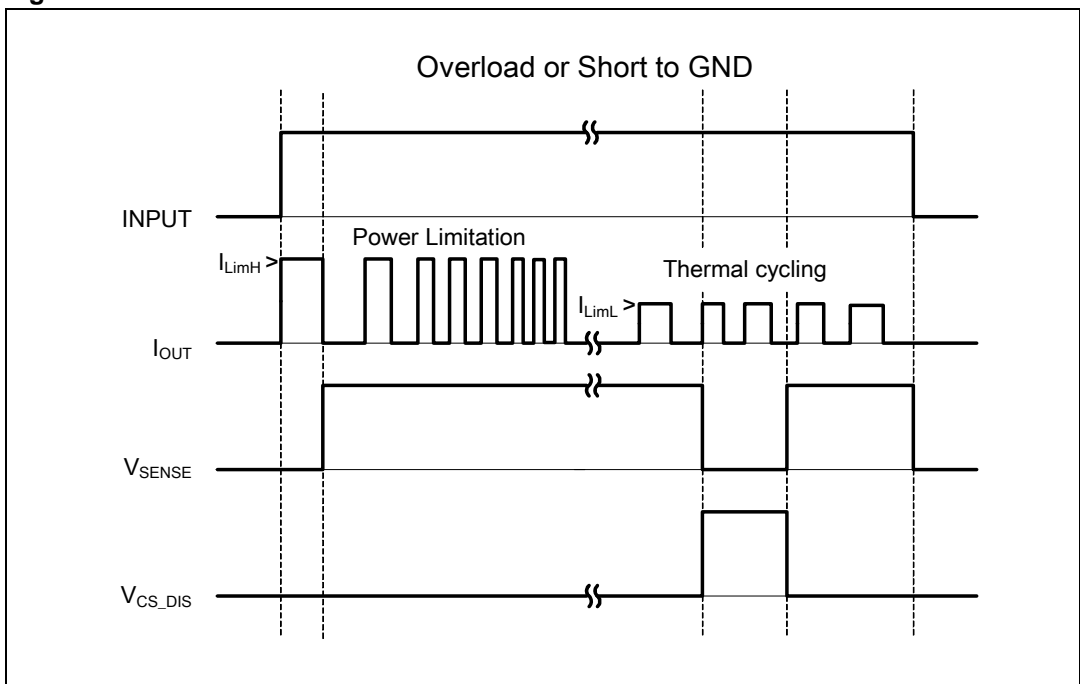

Figure 13. Intermittent overload

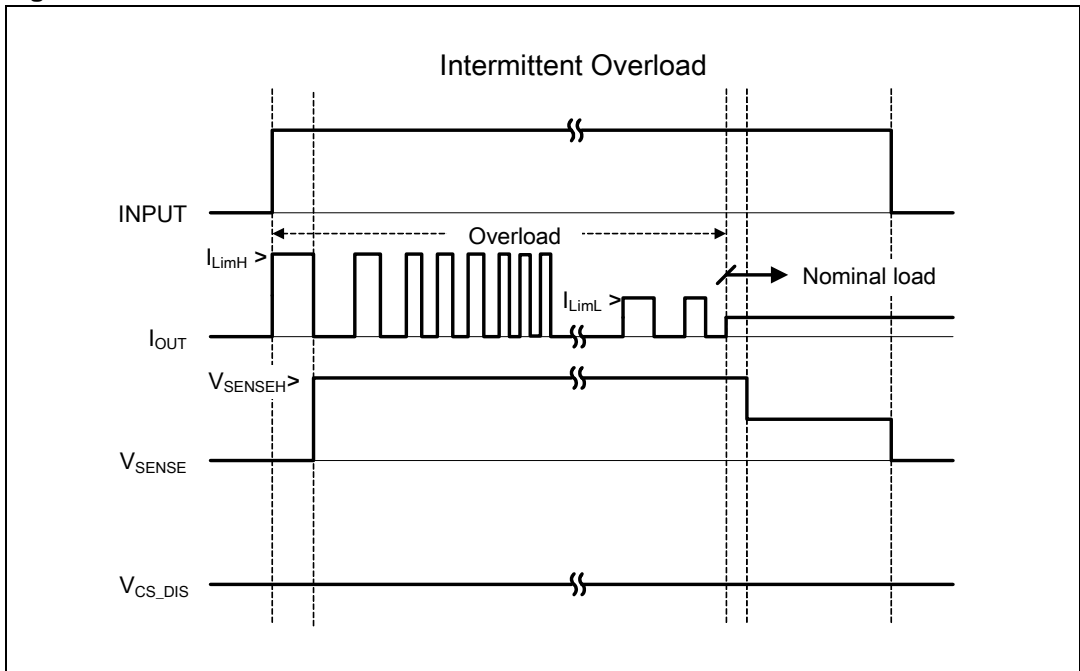

Figure 14. Off-state open-load with external circuitry

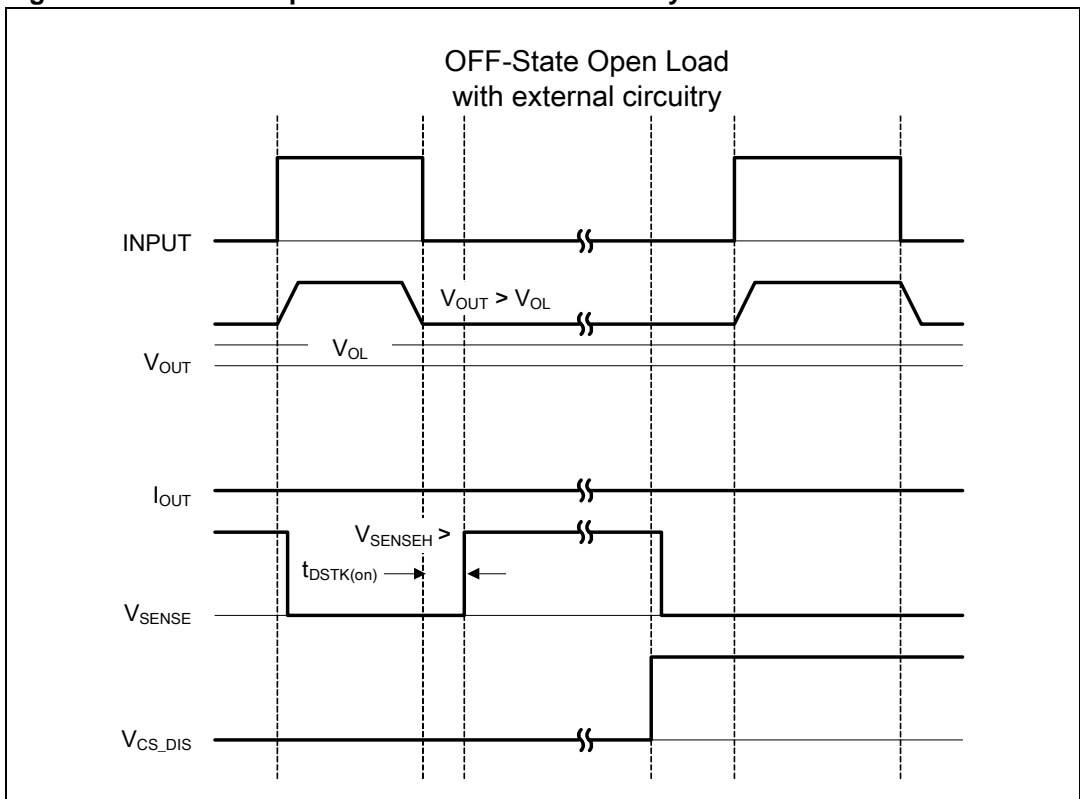

Figure 15. Short to V_{CC}

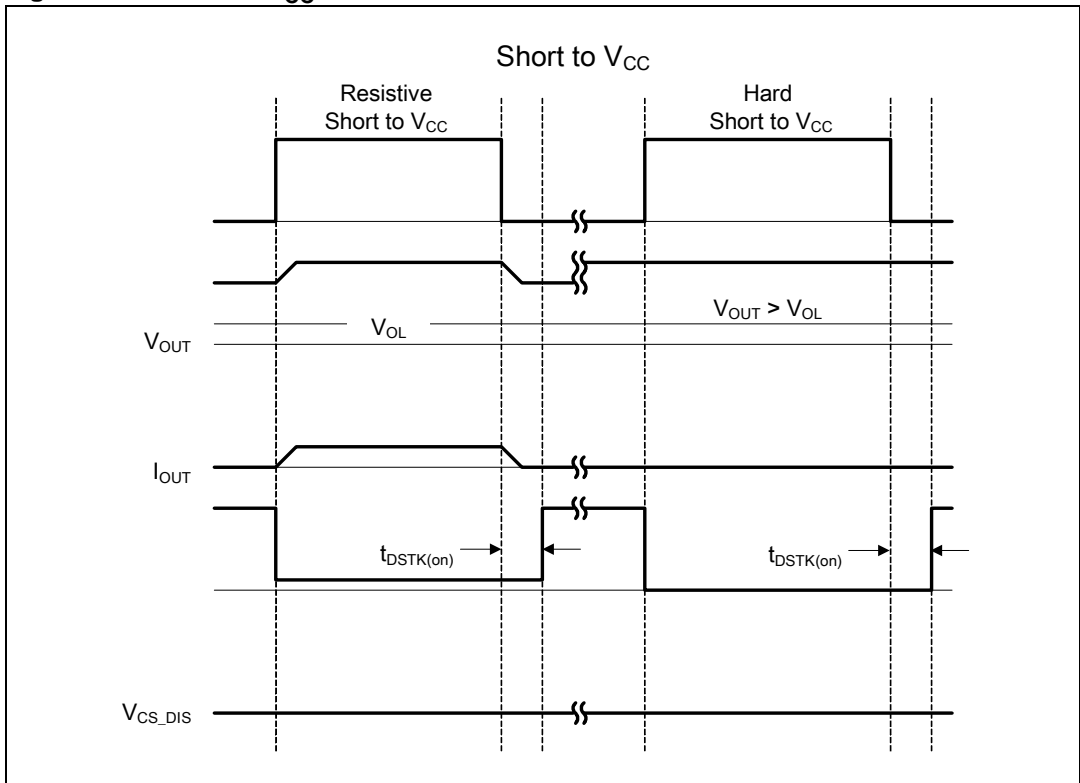
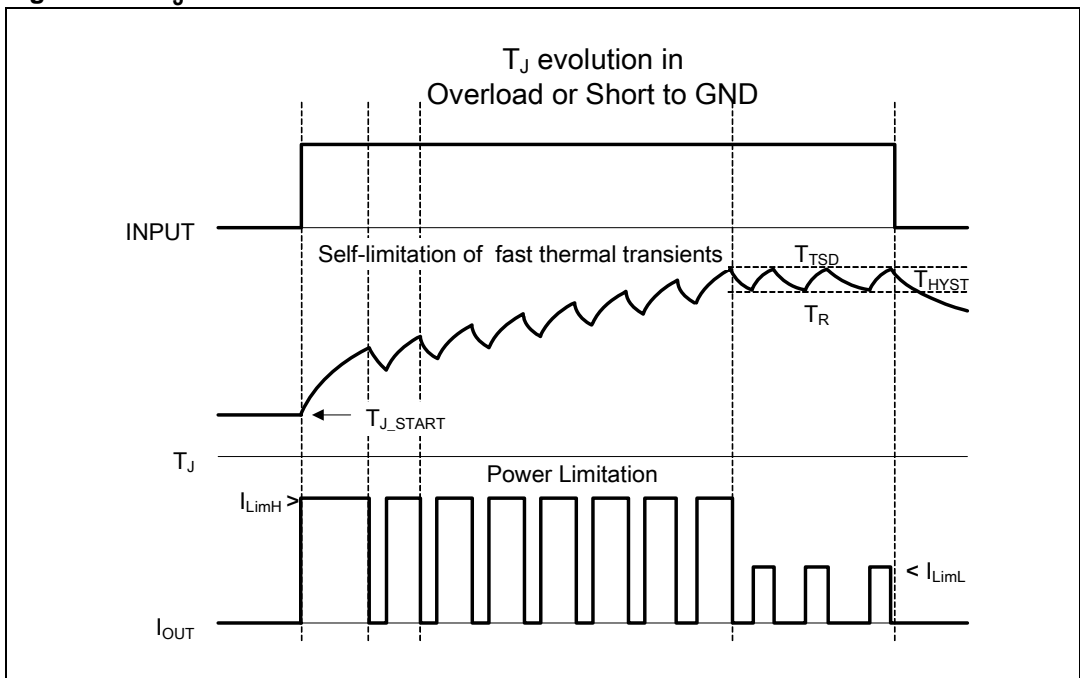

Figure 16. T_J evolution in overload or short to GND



2.5 Electrical characteristics curves

Figure 17. Off-state output current

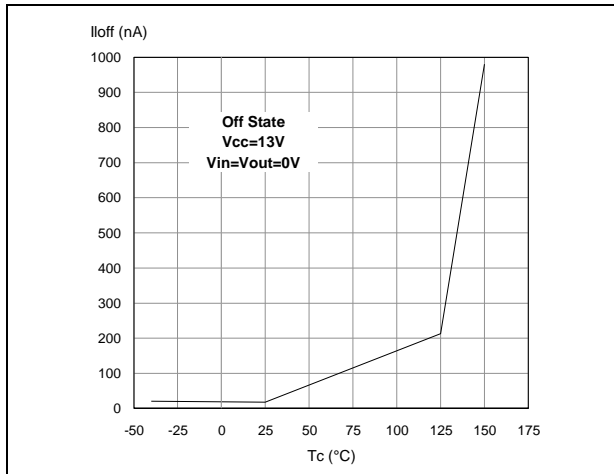

Figure 18. High level input current

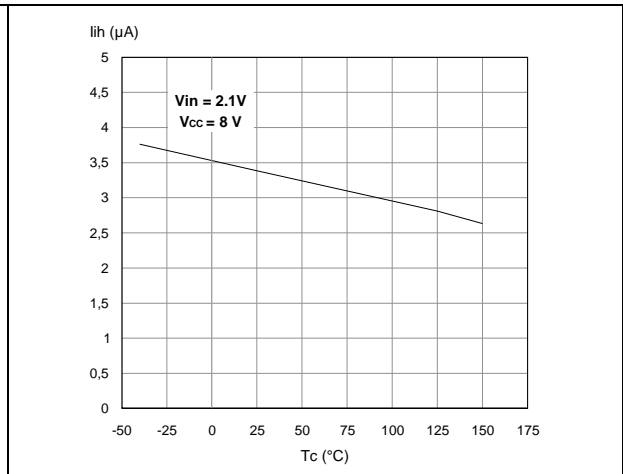

Figure 19. Input clamp voltage

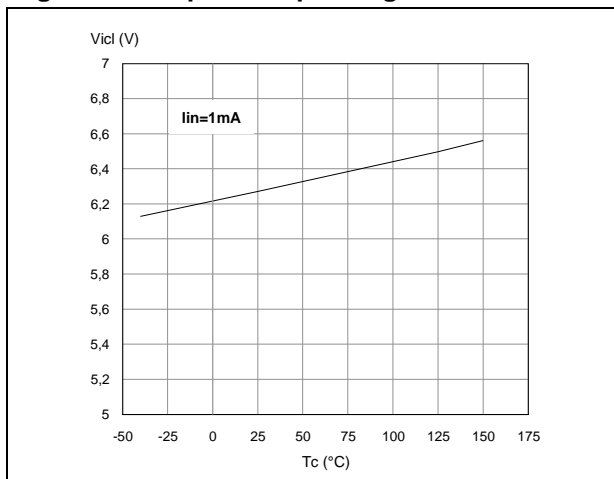

Figure 20. Input high level voltage

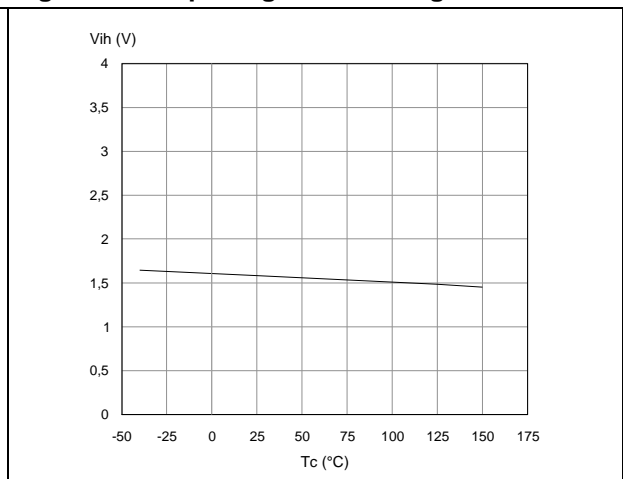

Figure 21. Input low level voltage

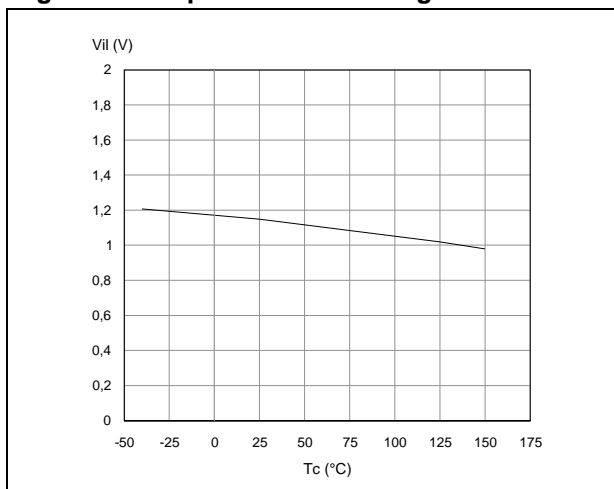

Figure 22. Input hysteresis voltage

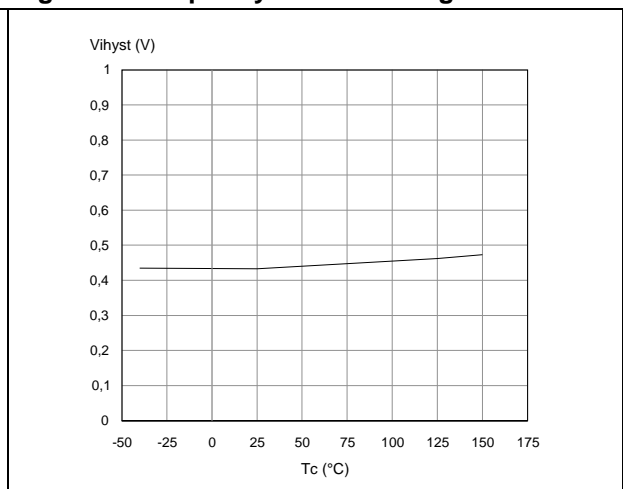

Figure 23. On-state resistance vs T_{case}

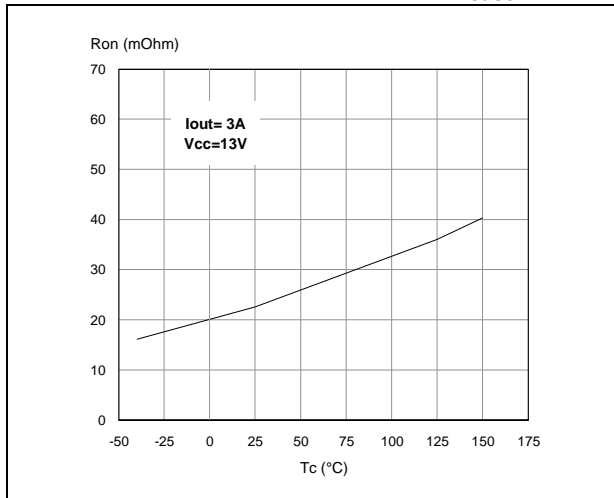

Figure 24. On-state resistance vs V_{CC}

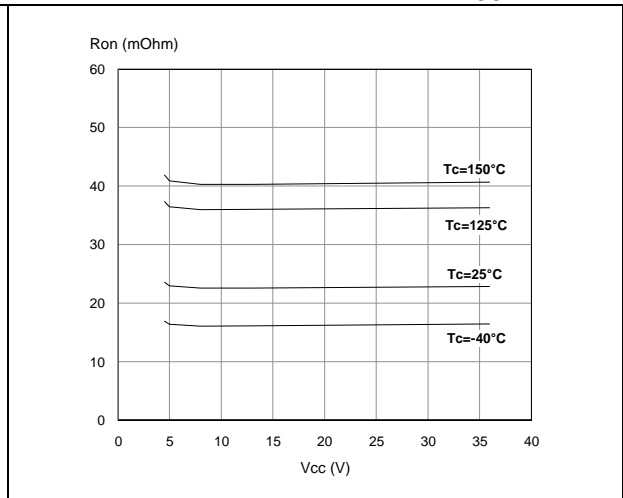

Figure 25. Undervoltage shutdown

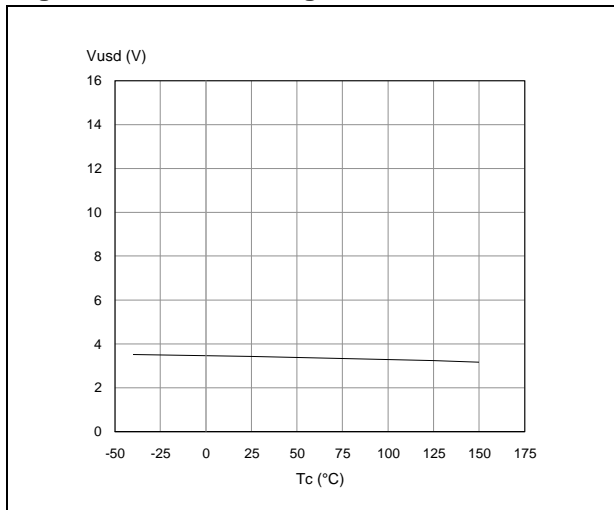

Figure 26. I_{LIMH} vs T_{case}

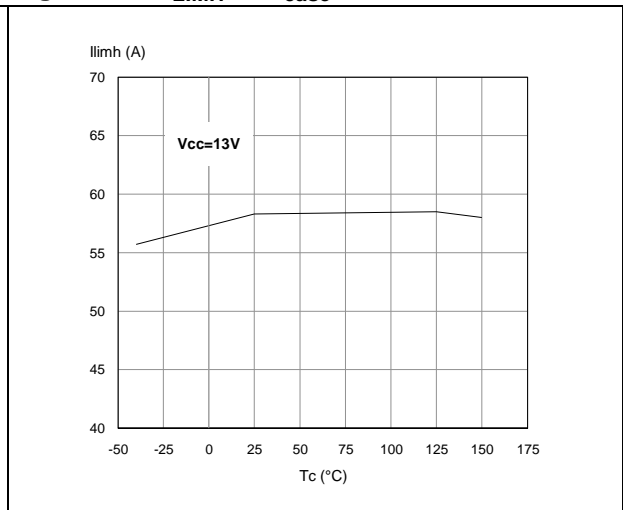

Figure 27. Turn-on voltage slope

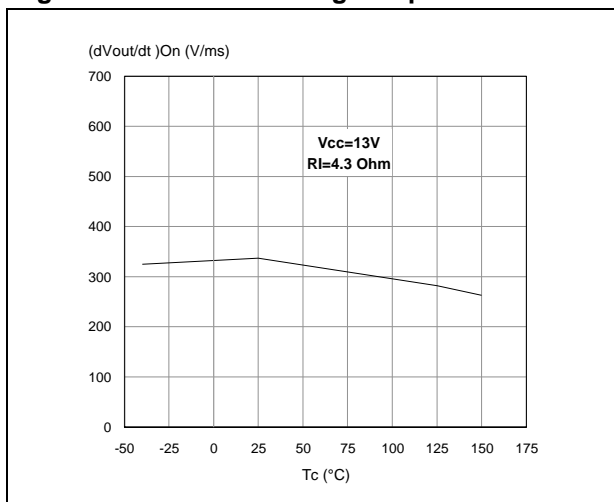

Figure 28. Turn-off voltage slope

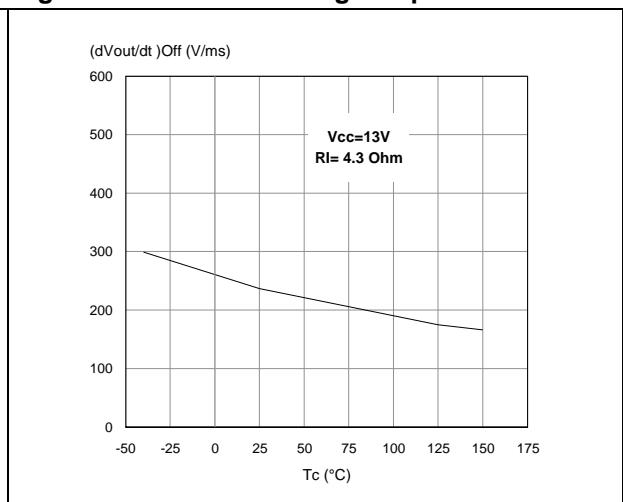

Figure 29. CS_DIS high level voltage

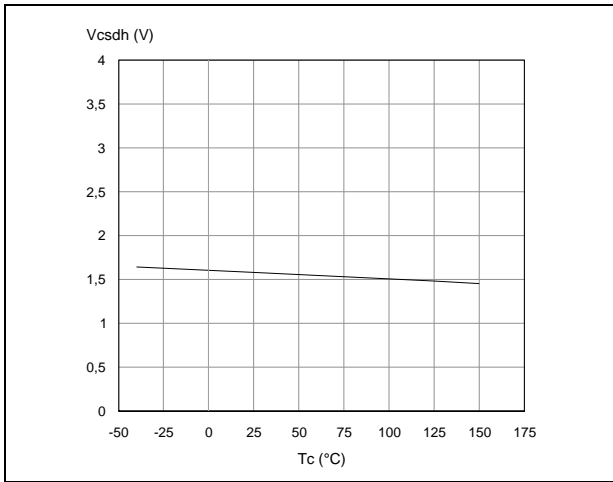

Figure 30. CS_DIS low level voltage

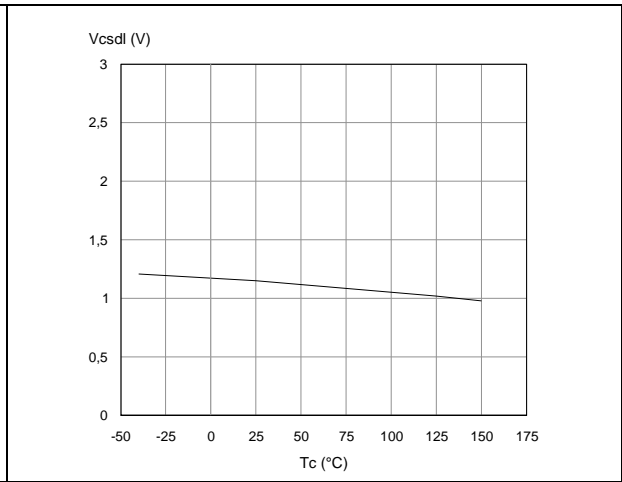
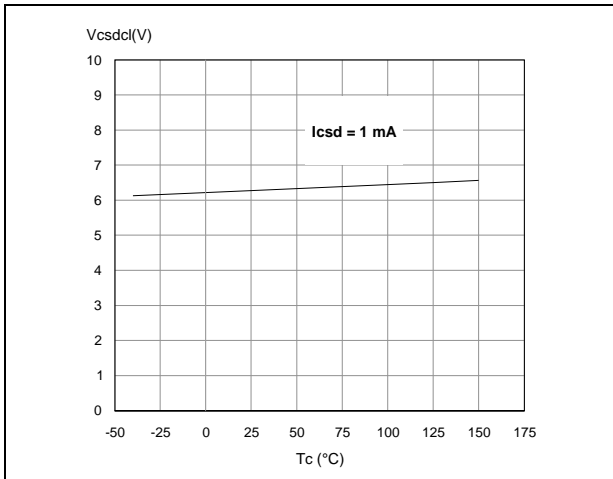

Figure 31. CS_DIS clamp voltage



If the calculated power dissipation leads to a large resistor or several devices have to share the same resistor then ST suggests to utilize Solution 2 (see below).

3.1.2 Solution 2: diode (D_{GND}) in the ground line

A resistor ($R_{GND}=1k\Omega$) should be inserted in parallel to D_{GND} if the device drives an inductive load.

This small signal diode can be safely shared amongst several different HSDs. Also in this case, the presence of the ground network produces a shift ($\approx 600mV$) in the input threshold and in the status output values if the microprocessor ground is not common to the device ground. This shift not varies if more than one HSD shares the same diode/resistor network.

3.2 Load dump protection

D_{ld} is necessary (Voltage Transient Suppressor) if the load dump peak voltage exceeds the V_{CC} max DC rating. The same applies if the device is subject to transients on the V_{CC} line that are greater than the ones shown in the ISO 7637-2: 2004(E) table.

3.3 MCU I/Os protection

If a ground protection network is used and negative transient are present on the V_{CC} line, the control pins are pulled negative. ST suggests to insert a resistor (R_{prot}) in line to prevent the microcontroller I/Os pins to latch-up.

The value of these resistors is a compromise between the leakage current of microcontroller and the current required by the HSD I/Os (Input levels compatibility) with the latch-up limit of microcontroller I/Os:

$$-V_{CCpeak}/I_{latchup} \leq R_{prot} \leq (V_{OH\mu C} - V_{IH} - V_{GND}) / I_{IHmax}$$

Calculation example:

For $V_{CCpeak} = -100V$ and $I_{latchup} \geq 20mA$; $V_{OH\mu C} \geq 4.5V$

$$5k\Omega \leq R_{prot} \leq 180k\Omega$$

Recommended values: $R_{prot} = 10k\Omega$, $C_{EXT} = 10nF$.

3.4 Current sense and diagnostic

The current sense pin performs a double function (see [Figure 33: Current sense and diagnostic](#)):

- **Current mirror of the load current in normal operation**, delivering a current proportional to the load one according to a know ratio K_x . The current I_{SENSE} can be easily converted to a voltage V_{SENSE} by means of an external resistor R_{SENSE} . Linearity between I_{OUT} and V_{SENSE} is ensured up to 5V minimum (see parameter V_{SENSE} in [Table 9: Current sense \(8 V < \$V_{CC}\$ < 18 V\)](#)). The current sense accuracy depends on the output current (refer to current sense electrical characteristics [Table 9: Current sense \(8 V < \$V_{CC}\$ < 18 V\)](#)).
- **Diagnostic flag in fault conditions**, delivering a fixed voltage V_{SENSEH} up to a maximum current I_{SENSEH} in case of the following fault conditions (refer to [Table 11: Truth table](#)):
 - Power limitation activation
 - Overtemperature
 - Short to V_{CC} in off-state
 - Open-load in off-state with additional external components.

A logic level high on CS_DIS pin sets at the same time all the current sense pins of the device in a high impedance state, thus disabling the current monitoring and diagnostic detection. This feature allows multiplexing of the microcontroller analog inputs by sharing of sense resistance and ADC line among different devices.

Figure 33. Current sense and diagnostic

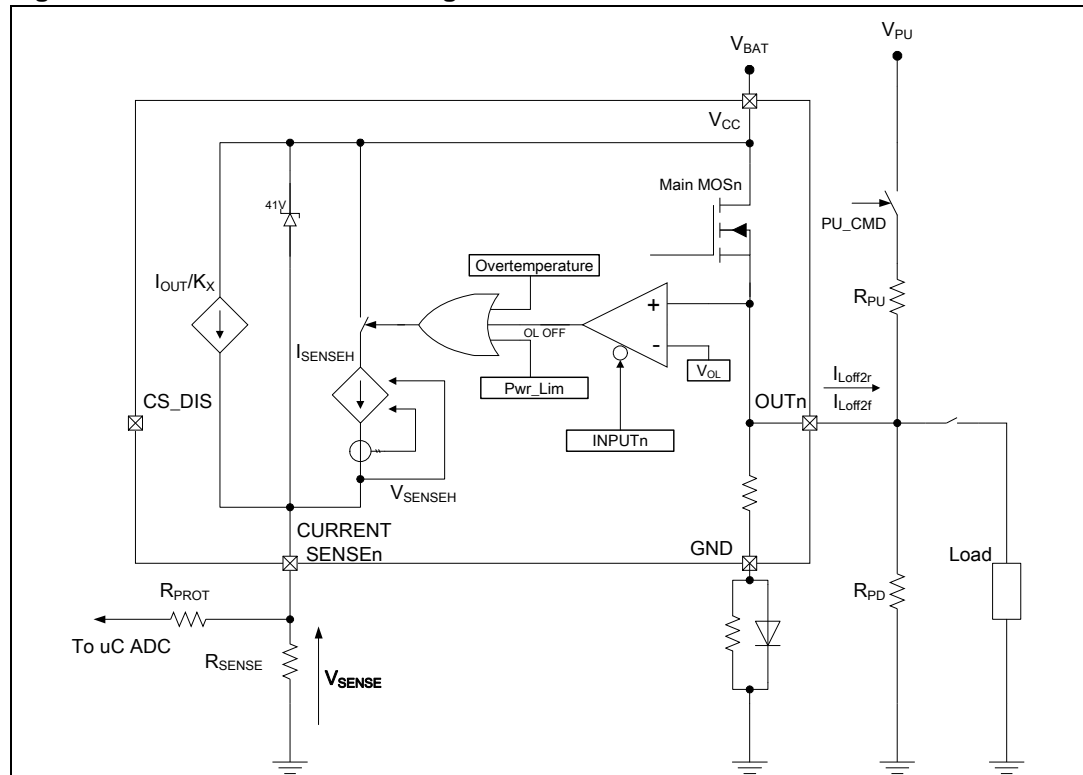

3.4.1 Short to V_{CC} and off-state open-load detection

Short to V_{CC}

A short circuit between V_{CC} and output is indicated by the relevant current sense pin set to V_{SENSEH} during the device off-state. Small or no current is delivered by the current sense during the on-state depending on the nature of the short circuit.

Off-state open-load with external circuitry

Detection of an open-load in off mode requires an external pull-up resistor R_{PU} connecting the output to a positive supply voltage V_{PU} .

It is preferable V_{PU} to be switched off during the module standby mode in order to avoid the overall standby current consumption to increase in normal conditions, i.e. when load is connected.

An external pull down resistor R_{PD} connected between output and GND is mandatory to avoid misdetection in case of floating outputs in off-state (see [Figure 33: Current sense and diagnostic](#)).

R_{PD} must be selected in order to ensure $V_{OUT} < V_{OLmin}$ unless pulled up by the external circuitry:

$$V_{OUT}|_{Pull-up_OFF} = R_{PD} \cdot I_{L(off)2f} < V_{OLmin} = 2V$$

$R_{PD} \leq 22 \text{ K}\Omega$ is recommended.

For proper open-load detection in off-state, the external pull-up resistor must be selected according to the following formula:

$$V_{OUT}|_{Pull-up_ON} = \frac{R_{PD} \cdot V_{PU} - R_{PU} \cdot R_{PD} \cdot I_{L(off)2r}}{R_{PU} + R_{PD}} > V_{OLmax} = 4V$$

For the values of V_{OLmin} , V_{OLmax} , $I_{L(off)2r}$ and $I_{L(off)2f}$ see [Table 10: Open-load detection \(8 V < \$V_{CC}\$ < 18 V\)](#).

3.5 Maximum demagnetization energy ($V_{CC} = 13.5\text{ V}$)

Figure 34. Maximum turn-off current versus inductance (for each channel)⁽¹⁾

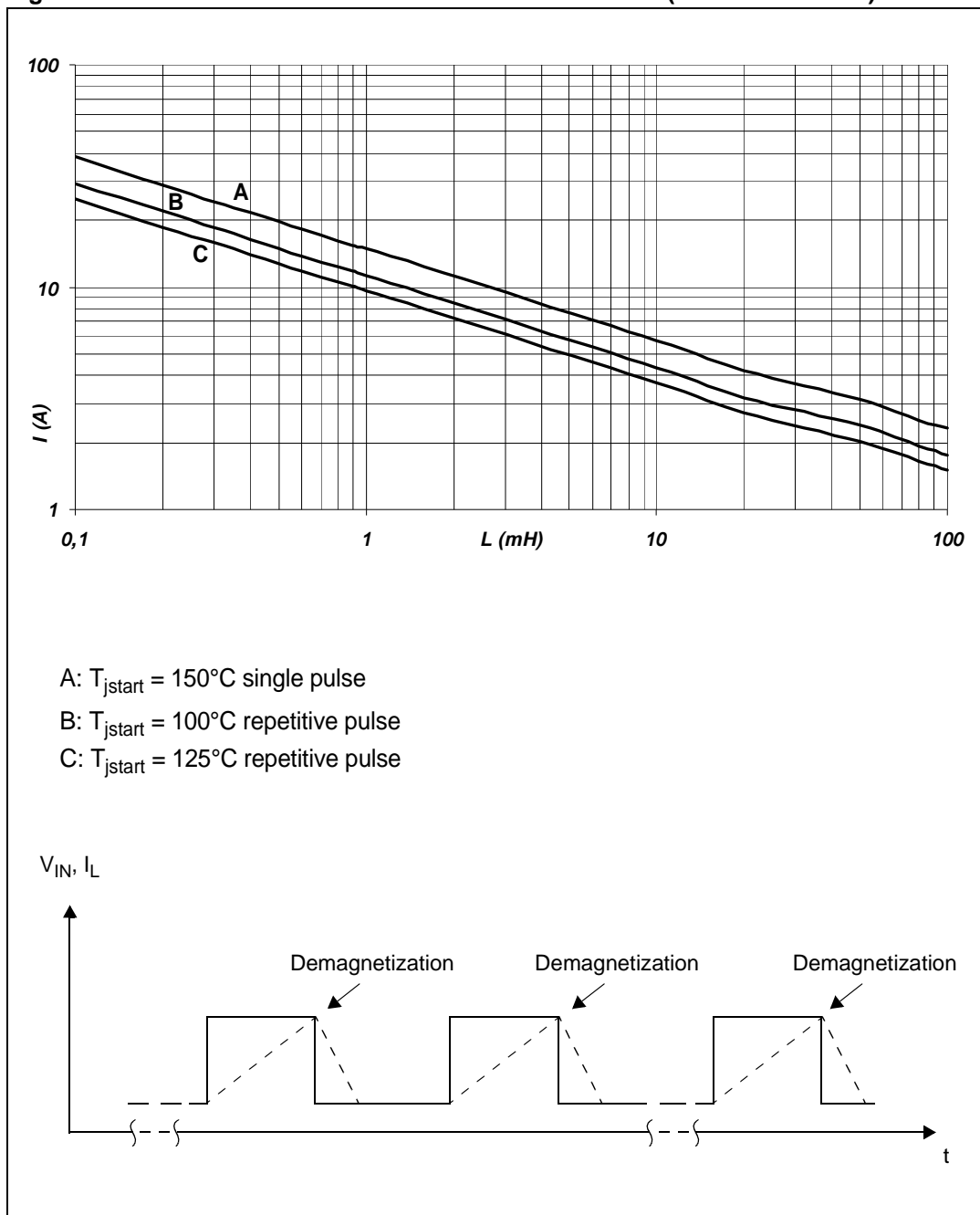

1. Values are generated with $R_{\theta} = 0\ \Omega$.
 In case of repetitive pulses, T_{jstart} (at beginning of each demagnetization) of every pulse must not exceed the temperature specified above for curves A and B.

4 Package and thermal data

4.1 PowerSSO-24 thermal data

Figure 35. PowerSSO-24 PC board⁽¹⁾

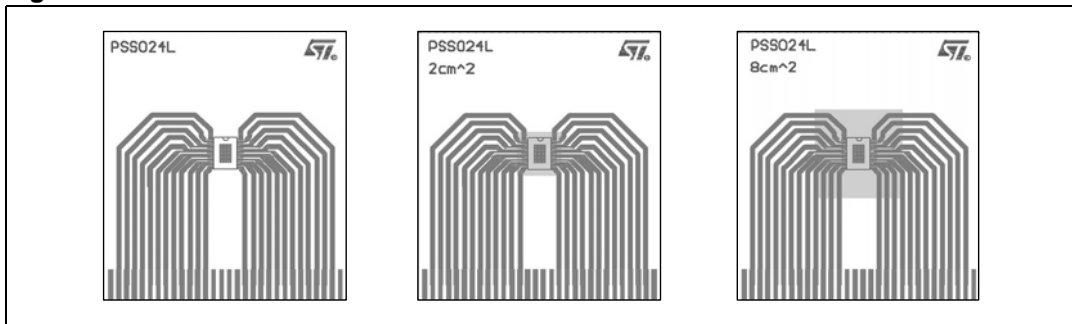

1. Layout condition of R_{th} and Z_{th} measurements (PCB: Double layer, Thermal Vias, FR4 area = 77 mm x 86mm, PCB thickness = 1.6 mm, Cu thickness = 70 μ m (front and back side), Copper areas: from minimum pad layout to 8 cm²).

Figure 36. $R_{thj-amb}$ vs PCB copper area in open box free air condition (one channel on)

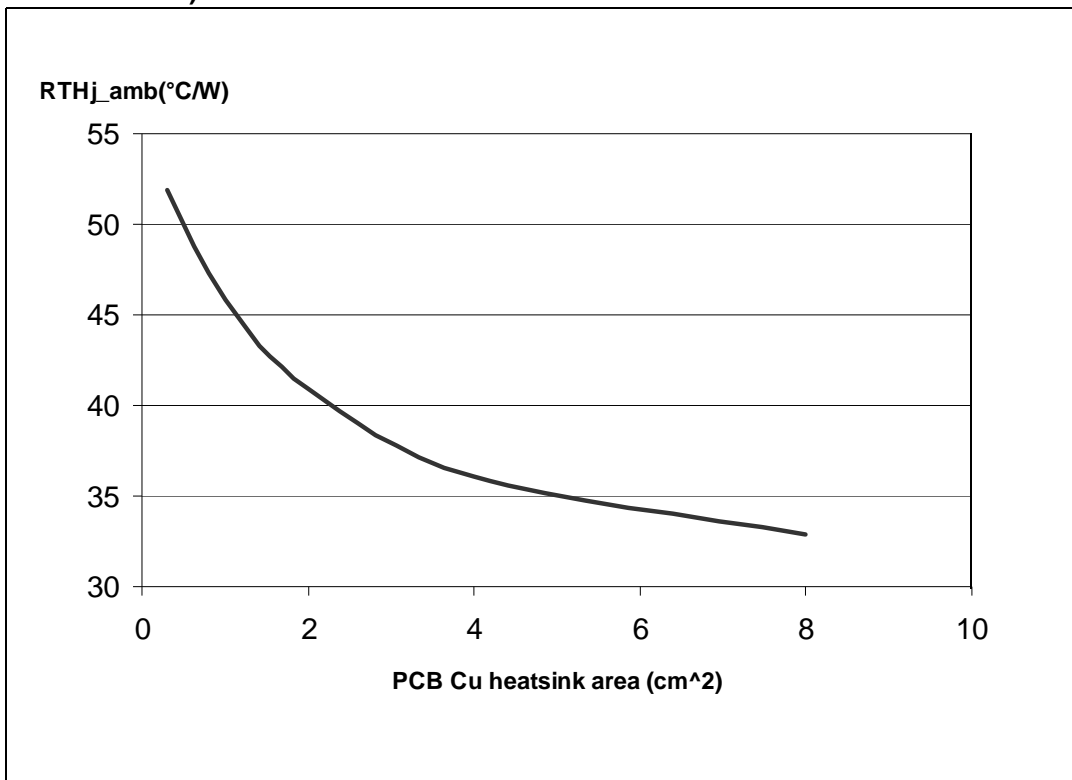
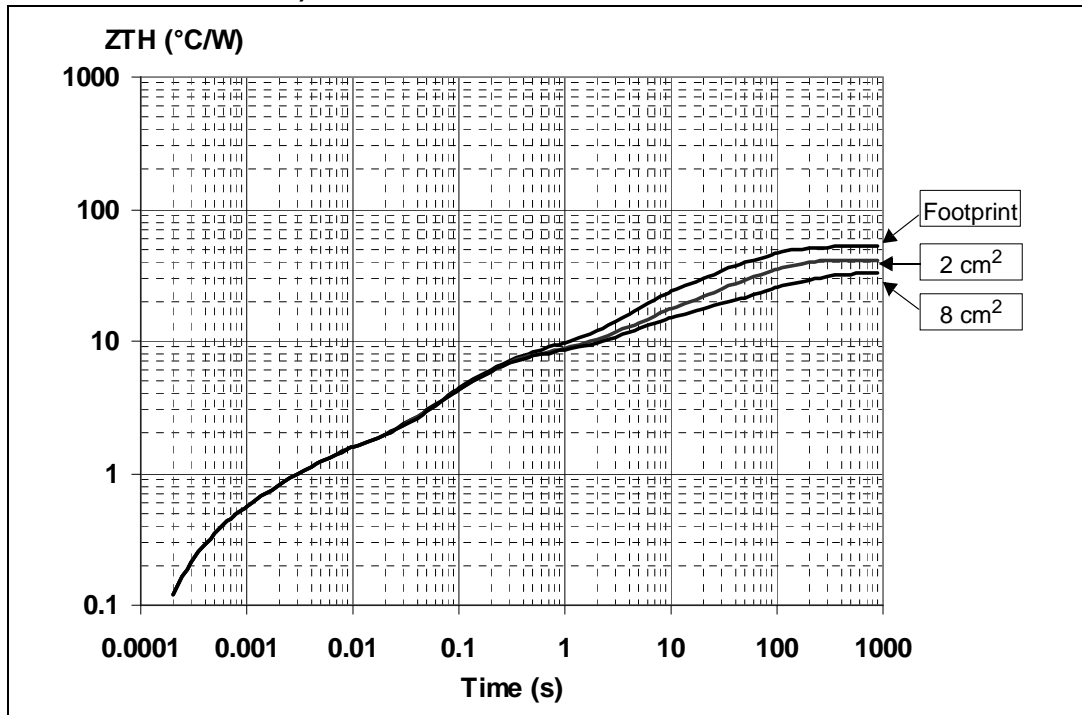

Figure 37. PowerSSO-24 thermal impedance junction to ambient single pulse (one channel on)



Equation 1: pulse calculation formula

$$Z_{TH\delta} = R_{TH} \cdot \delta + Z_{THtp}(1 - \delta)$$

where $\delta = t_p/T$

Figure 38. Thermal fitting model of a double channel HSD in PowerSSO-24⁽¹⁾

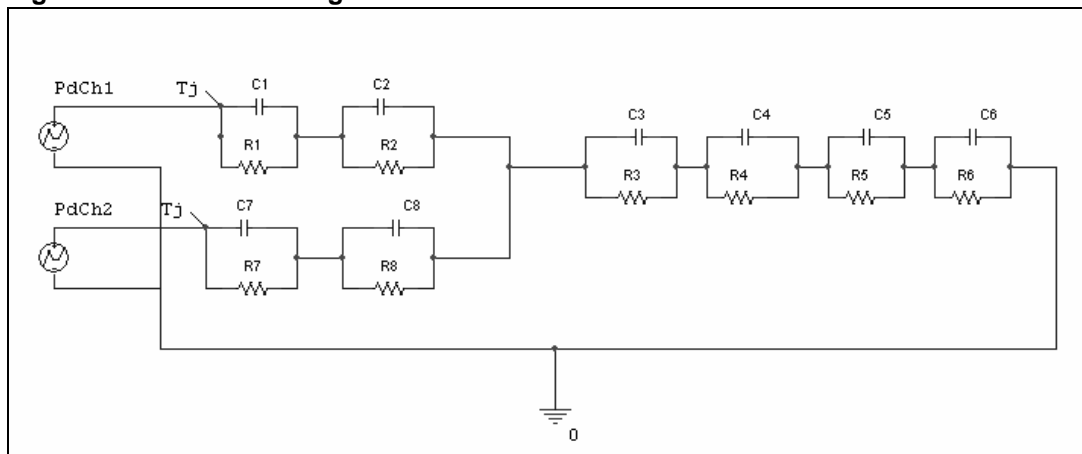

1. The fitting model is a simplified thermal tool and is valid for transient evolutions where the embedded protections (power limitation or thermal cycling during thermal shutdown) are not triggered.

Table 15. Thermal parameters

| Area/Island (cm ²) | Footprint | 2 | 8 |
|--------------------------------|-----------|----|----|
| R1 (°C/W) | 0.28 | | |
| R2 (°C/W) | 0.9 | | |
| R3 (°C/W) | 6 | | |
| R4 (°C/W) | 7.7 | | |
| R5 (°C/W) | 9 | 9 | 8 |
| R6 (°C/W) | 28 | 17 | 10 |
| R7 (°C/W) | 0.28 | | |
| R8 (°C/W) | 0.9 | | |
| C1 (W.s/°C) | 0.001 | | |
| C2 (W.s/°C) | 0.003 | | |
| C3 (W.s/°C) | 0.025 | | |
| C4 (W.s/°C) | 0.75 | | |
| C5 (W.s/°C) | 1 | 4 | 9 |
| C6 (W.s/°C) | 2.2 | 5 | 17 |
| C7 (W.s/°C) | 0.001 | | |
| C8 (W.s/°C) | 0.003 | | |

5 Package and packing information

5.1 ECOPACK[®] packages

In order to meet environmental requirements, ST offers these devices in different grades of ECOPACK[®] packages, depending on their level of environmental compliance. ECOPACK[®] specifications, grade definitions and product status are available at: www.st.com.

ECOPACK[®] is an ST trademark.

5.2 Package mechanical data

Figure 39. PowerSSO-24 package dimensions

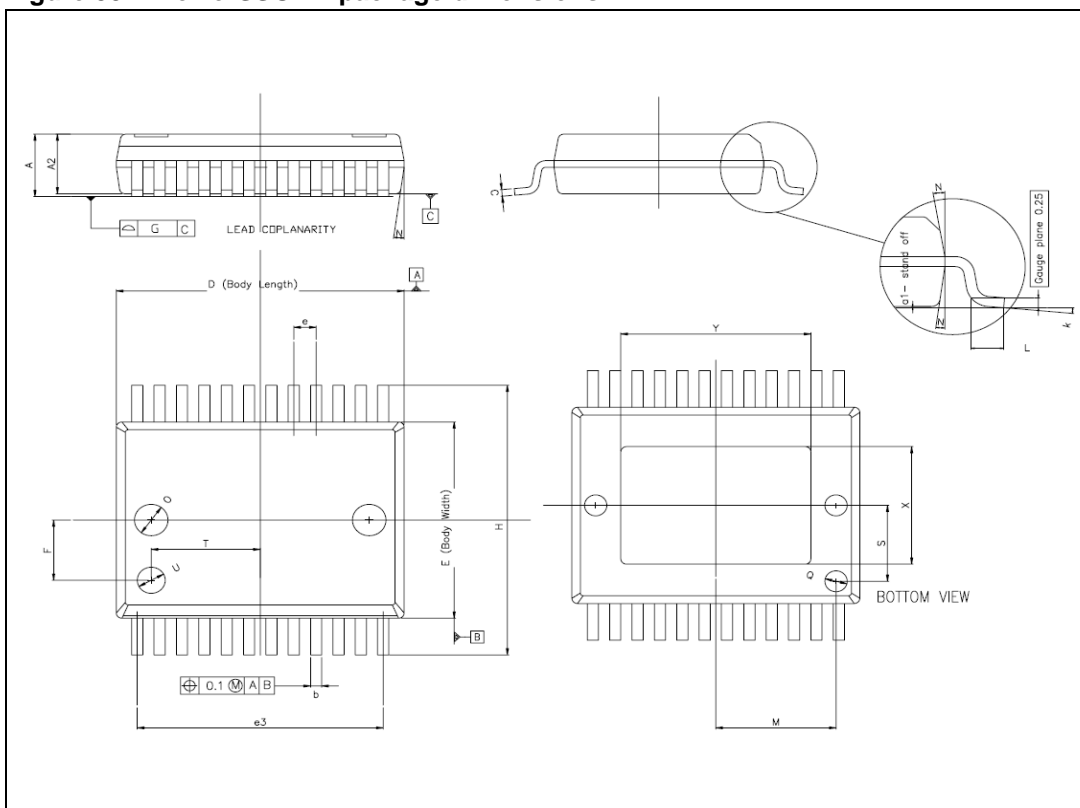

Table 16. PowerSSO-24™ mechanical data

| Symbol | Millimeters | | |
|--------|-------------|------|-------|
| | Min | Typ | Max |
| A | | | 2.45 |
| A2 | 2.15 | | 2.35 |
| a1 | 0 | | 0.1 |
| b | 0.33 | | 0.51 |
| c | 0.23 | | 0.32 |
| D | 10.10 | | 10.50 |
| E | 7.4 | | 7.6 |
| e | | 0.8 | |
| e3 | | 8.8 | |
| F | | 2.3 | |
| G | | | 0.1 |
| H | 10.1 | | 10.5 |
| h | | | 0.4 |
| k | 0° | | 8° |
| L | 0.55 | | 0.85 |
| O | | 1.2 | |
| Q | | 0.8 | |
| S | | 2.9 | |
| T | | 3.65 | |
| U | | 1.0 | |
| N | | | 10° |
| X | 4.1 | | 4.7 |
| Y | 6.5 | | 7.1 |

5.3 Packing information

Figure 40. PowerSSO-24 tube shipment (no suffix)

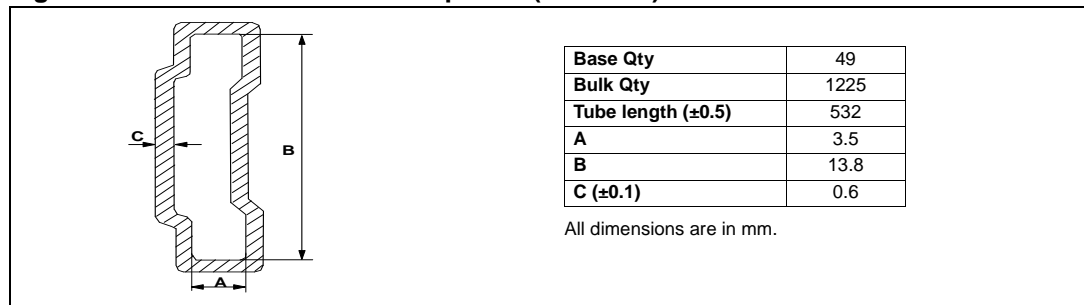
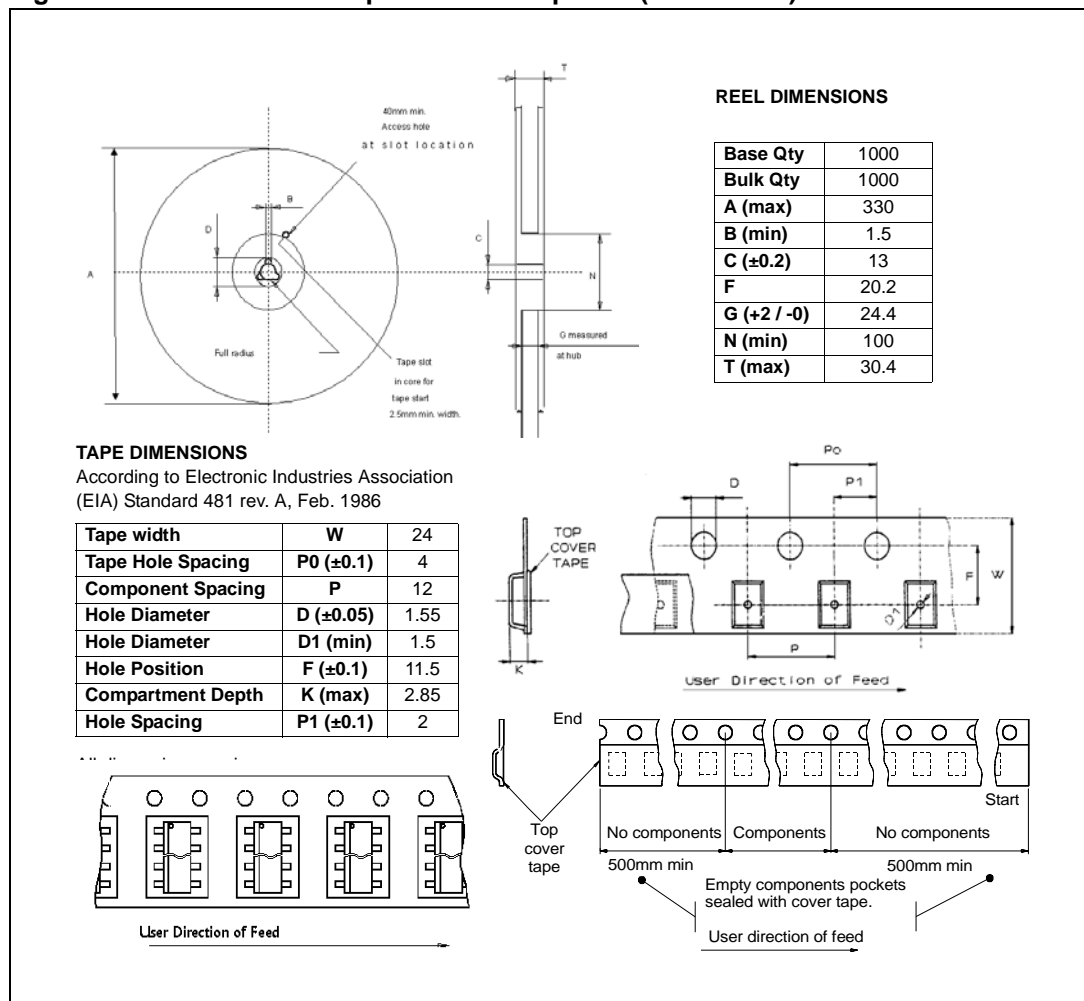

Figure 41. PowerSSO-24 tape and reel shipment (suffix "TR")



6 Order codes

Table 17. Device summary

| Package | Order codes | |
|-------------|--------------|----------------|
| | Tube | Tape and reel |
| PowerSSO-24 | VND5E025AK-E | VND5E025AKTR-E |

7 Revision history

Table 18. Document revision history

| Date | Revision | Changes |
|-------------|----------|---|
| 01-Apr-2008 | 1 | Initial release |
| 19-Jun-2009 | 2 | <p><i>Table 16: PowerSSO-24 mechanical data:</i></p> <ul style="list-style-type: none"> – Deleted A (min) value – Changed A (max) value from 2.47 to 2.45 – Changed A2 (max) value from 2.40 to 2.35 – Changed a1 (max) value from 0.075 to 0.1 – Added F row – Updated k row |
| 22-Jul-2009 | 3 | <p>Updated <i>Figure 39: PowerSSO-24 package dimensions.</i></p> <p>Updated <i>Table 16: PowerSSO-24™ mechanical data:</i></p> <ul style="list-style-type: none"> – Deleted G1 row – Added O, Q, S, T and U rows |
| 28-May-2010 | 4 | Updated <i>Features</i> list. |
| 19-Sep-2013 | 5 | Updated disclaimer. |

Please Read Carefully:

Information in this document is provided solely in connection with ST products. STMicroelectronics NV and its subsidiaries ("ST") reserve the right to make changes, corrections, modifications or improvements, to this document, and the products and services described herein at any time, without notice.

All ST products are sold pursuant to ST's terms and conditions of sale.

Purchasers are solely responsible for the choice, selection and use of the ST products and services described herein, and ST assumes no liability whatsoever relating to the choice, selection or use of the ST products and services described herein.

No license, express or implied, by estoppel or otherwise, to any intellectual property rights is granted under this document. If any part of this document refers to any third party products or services it shall not be deemed a license grant by ST for the use of such third party products or services, or any intellectual property contained therein or considered as a warranty covering the use in any manner whatsoever of such third party products or services or any intellectual property contained therein.

UNLESS OTHERWISE SET FORTH IN ST'S TERMS AND CONDITIONS OF SALE ST DISCLAIMS ANY EXPRESS OR IMPLIED WARRANTY WITH RESPECT TO THE USE AND/OR SALE OF ST PRODUCTS INCLUDING WITHOUT LIMITATION IMPLIED WARRANTIES OF MERCHANTABILITY, FITNESS FOR A PARTICULAR PURPOSE (AND THEIR EQUIVALENTS UNDER THE LAWS OF ANY JURISDICTION), OR INFRINGEMENT OF ANY PATENT, COPYRIGHT OR OTHER INTELLECTUAL PROPERTY RIGHT.

ST PRODUCTS ARE NOT DESIGNED OR AUTHORIZED FOR USE IN: (A) SAFETY CRITICAL APPLICATIONS SUCH AS LIFE SUPPORTING, ACTIVE IMPLANTED DEVICES OR SYSTEMS WITH PRODUCT FUNCTIONAL SAFETY REQUIREMENTS; (B) AERONAUTIC APPLICATIONS; (C) AUTOMOTIVE APPLICATIONS OR ENVIRONMENTS, AND/OR (D) AEROSPACE APPLICATIONS OR ENVIRONMENTS. WHERE ST PRODUCTS ARE NOT DESIGNED FOR SUCH USE, THE PURCHASER SHALL USE PRODUCTS AT PURCHASER'S SOLE RISK, EVEN IF ST HAS BEEN INFORMED IN WRITING OF SUCH USAGE, UNLESS A PRODUCT IS EXPRESSLY DESIGNATED BY ST AS BEING INTENDED FOR "AUTOMOTIVE, AUTOMOTIVE SAFETY OR MEDICAL" INDUSTRY DOMAINS ACCORDING TO ST PRODUCT DESIGN SPECIFICATIONS. PRODUCTS FORMALLY ESCC, QML OR JAN QUALIFIED ARE DEEMED SUITABLE FOR USE IN AEROSPACE BY THE CORRESPONDING GOVERNMENTAL AGENCY.

Resale of ST products with provisions different from the statements and/or technical features set forth in this document shall immediately void any warranty granted by ST for the ST product or service described herein and shall not create or extend in any manner whatsoever, any liability of ST.

ST and the ST logo are trademarks or registered trademarks of ST in various countries.

Information in this document supersedes and replaces all information previously supplied.

The ST logo is a registered trademark of STMicroelectronics. All other names are the property of their respective owners.

© 2013 STMicroelectronics - All rights reserved

STMicroelectronics group of companies

Australia - Belgium - Brazil - Canada - China - Czech Republic - Finland - France - Germany - Hong Kong - India - Israel - Italy - Japan - Malaysia - Malta - Morocco - Philippines - Singapore - Spain - Sweden - Switzerland - United Kingdom - United States of America

www.st.com

Looking for pricing, stock, or lifecycle information?

Click below to explore more details on WIN SOURCE:

- ⊖ [View VND5E025AKTR-E on WIN SOURCE](#)
- ⊖ [STMicroelectronics Information](#)

Optimize Your Supply Chain with WIN SOURCE Solutions

- ✓ Global Sourcing Solution
- ✓ Obsolete Management
- ✓ Cost Control Management
- ✓ Shortage Management
- ✓ Alternative Solution
- ✓ Excess Inventory Management