



**THE DATASHEET OF
VN750PSTR-E**



Features

| Type | $R_{DS(on)}$ | I_{OUT} | V_{CC} |
|-----------|---------------|-----------|----------|
| VN750PS-E | 60 m Ω | 6 A | 36 V |

- ECOPACK[®] : lead free and RoHS compliant
- Automotive Grade: compliance with AEC guidelines
- CMOS compatible input
- On-state open-load detection
- Off-state open-load detection
- Shorted load protection
- Undervoltage and overvoltage shutdown
- Protection against loss of ground
- Very low standby current
- Reverse battery protection

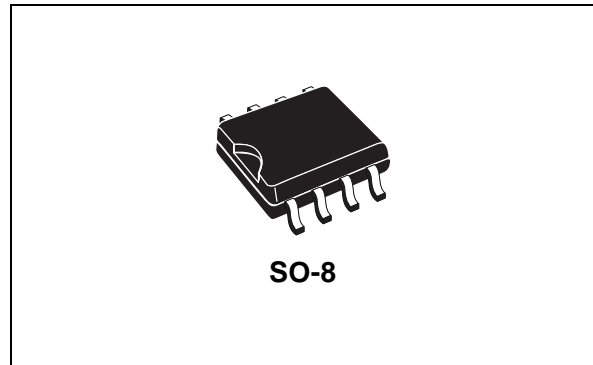

Description

The VN750PS-E is a monolithic device designed in STMicroelectronics™ VIPower™ M0-3 Technology intended for driving any kind of load with one side connected to ground.

Active V_{CC} pin voltage clamp protects the device against low energy spikes (see ISO7637 transient compatibility table). Active current limitation combined with thermal shutdown and automatic restart help protect the device against overload.

The device detects open load condition in on and off-state. Output shorted to V_{CC} is detected in the off-state. Device automatically turns off in case of ground pin disconnection.

Table 1. Device summary

| Package | Order codes | |
|---------|-------------|---------------|
| | Tube | Tape and reel |
| SO-8 | VN750PS-E | VN750PSTR-E |

Contents

| | | |
|----------|---|-----------|
| 1 | Block diagram and pin description | 5 |
| 2 | Electrical specifications | 6 |
| 2.1 | Absolute maximum ratings | 6 |
| 2.2 | Thermal data | 7 |
| 2.3 | Electrical characteristics | 8 |
| 2.4 | Electrical characteristics curves | 13 |
| 2.5 | GND protection network against reverse battery | 16 |
| 2.6 | Load dump protection | 17 |
| 2.7 | Microcontroller I/Os protection | 17 |
| 2.8 | Open-load detection in off-state | 17 |
| 2.9 | SO-8 maximum demagnetization energy ($V_{CC} = 13.5 \text{ V}$) | 19 |
| 3 | Package and PCB thermal data | 20 |
| 3.1 | SO-8 thermal data | 20 |
| 4 | Package and packing information | 23 |
| 4.1 | SO-8 package information | 23 |
| 4.2 | SO-8 packing information | 25 |
| 5 | Revision history | 26 |

List of tables

| | | |
|-----------|---|----|
| Table 1. | Device summary | 1 |
| Table 2. | Suggested connections for unused and not connected pins | 5 |
| Table 3. | Absolute maximum ratings | 6 |
| Table 4. | Thermal data | 7 |
| Table 5. | Electrical characteristics | 8 |
| Table 6. | Truth table. | 10 |
| Table 7. | Electrical transient requirements on V_{CC} pin (part 1/3). | 11 |
| Table 8. | Electrical transient requirements on V_{CC} pin (part 2/3). | 11 |
| Table 9. | Electrical transient requirements on V_{CC} pin (part 3/3). | 11 |
| Table 10. | Thermal parameter | 22 |
| Table 11. | SO-8 mechanical data | 24 |
| Table 12. | Document revision history | 26 |

List of figures

| | | |
|------------|---|----|
| Figure 1. | Block diagram | 5 |
| Figure 2. | Configuration diagram (top view) | 5 |
| Figure 3. | Current and voltage conventions | 6 |
| Figure 4. | Status timings | 10 |
| Figure 5. | Switching time waveforms | 10 |
| Figure 6. | Waveforms | 12 |
| Figure 7. | Off-state output current | 13 |
| Figure 8. | High level input current | 13 |
| Figure 9. | Input clamp voltage | 13 |
| Figure 10. | Status leakage current | 13 |
| Figure 11. | Status low output voltage | 13 |
| Figure 12. | Status clamp voltage | 13 |
| Figure 13. | On-state resistance vs T_{case} | 14 |
| Figure 14. | On-state resistance vs V_{CC} | 14 |
| Figure 15. | Open-load on-state detection threshold | 14 |
| Figure 16. | Input high level | 14 |
| Figure 17. | Input low level | 14 |
| Figure 18. | Input hysteresis voltage | 14 |
| Figure 19. | Overshoot shutdown | 15 |
| Figure 20. | Open-load off-state voltage detection threshold | 15 |
| Figure 21. | Turn-on voltage slope | 15 |
| Figure 22. | Turn-off voltage slope | 15 |
| Figure 23. | I_{lim} vs T_{case} | 15 |
| Figure 24. | Application schematic | 16 |
| Figure 25. | Open-load detection in off-state | 18 |
| Figure 26. | SO-8 maximum turn-off current versus inductance | 19 |
| Figure 27. | PC board | 20 |
| Figure 28. | $R_{thj-amb}$ vs PCB copper area in open box free air condition | 20 |
| Figure 29. | SO-8 thermal impedance junction ambient single pulse | 21 |
| Figure 30. | Thermal fitting model of a single channel | 21 |
| Figure 31. | SO-8 package dimensions | 23 |
| Figure 32. | SO-8 tube shipment (no suffix) | 25 |
| Figure 33. | SO-8 tape and reel shipment (suffix "TR") | 25 |

1 Block diagram and pin description

Figure 1. Block diagram

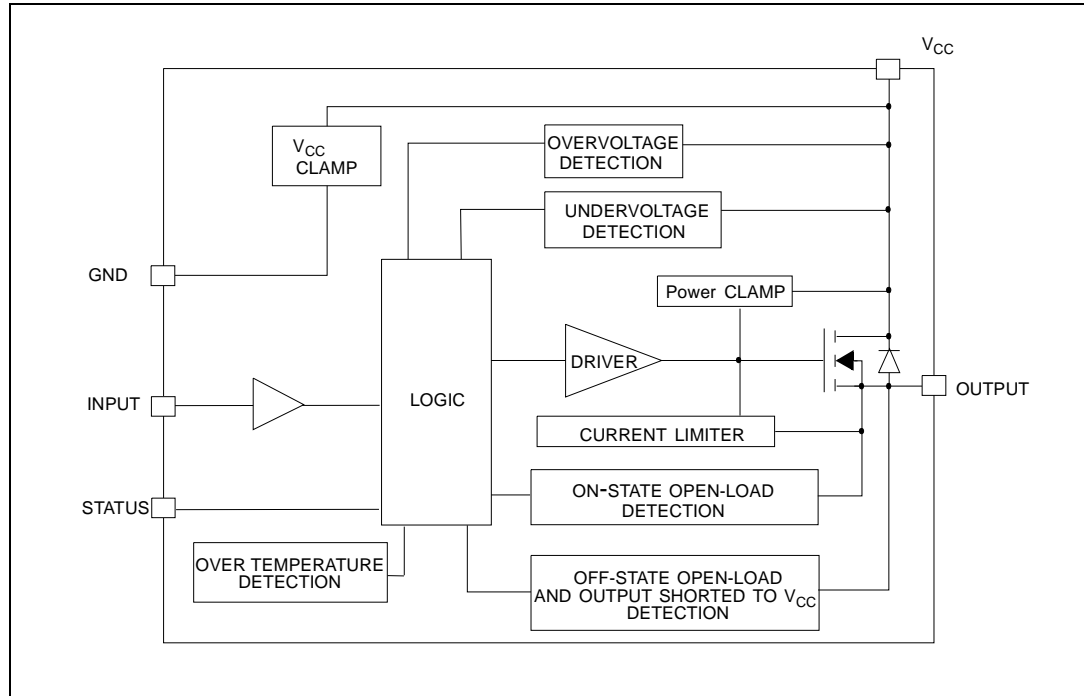

Figure 2. Configuration diagram (top view)

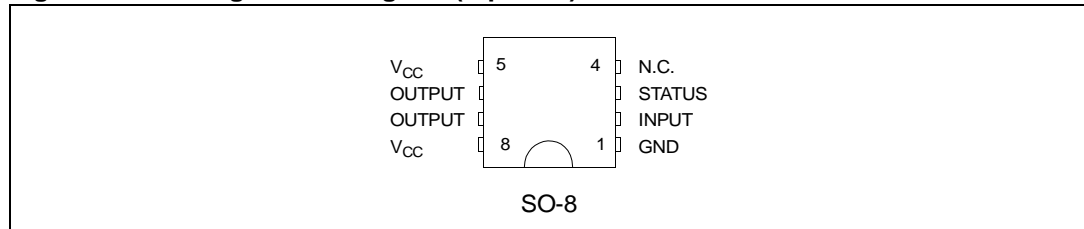
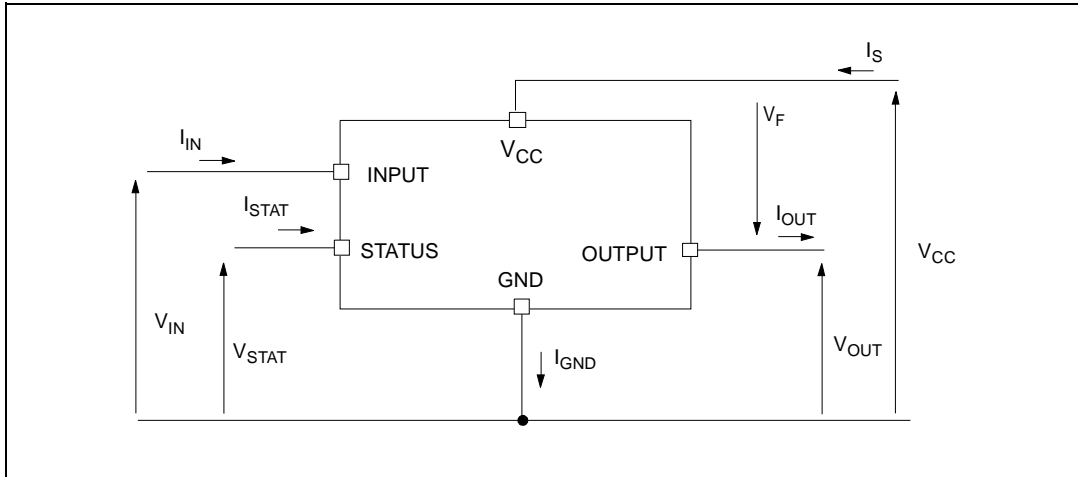

Table 2. Suggested connections for unused and not connected pins

| Connection/pin | Status | N.C. | Output | Input |
|----------------|--------|------|--------|------------------------|
| Floating | X | X | X | X |
| To ground | | X | | Through 10 KΩ resistor |

2 Electrical specifications

Figure 3. Current and voltage conventions



2.1 Absolute maximum ratings

Stress values that exceed those listed in the “Absolute maximum ratings” table can cause permanent damage to the device. These are stress ratings only and operation of the device at these or any other conditions greater than those indicated in the operating sections of this specification is not implied. Exposure to absolute maximum rating conditions for extended periods may affect device reliability. Refer also to the STMicroelectronics sure program and other relevant quality documents.

Table 3. Absolute maximum ratings

| Symbol | Parameter | Value | Unit |
|------------|--|--------------------|------|
| V_{CC} | DC supply voltage | 41 | V |
| $-V_{CC}$ | Reverse DC supply voltage | - 0.3 | V |
| $-I_{gnd}$ | DC reverse ground pin current | - 200 | mA |
| I_{OUT} | DC output current | Internally limited | A |
| $-I_{OUT}$ | Reverse DC output current | - 6 | A |
| I_{IN} | DC input current | +/-10 | mA |
| I_{STAT} | DC status current | +/- 10 | mA |
| V_{ESD} | Electrostatic discharge (human body model: R = 1.5 K Ω ; C = 100 pF) | | |
| | - Input | 4000 | V |
| | - Status | 4000 | V |
| | - Output | 5000 | V |
| | - V_{CC} | 5000 | V |

Table 3. Absolute maximum ratings (continued)

| Symbol | Parameter | Value | Unit |
|-----------|---|--------------------|------------------|
| E_{MAX} | Maximum switching energy ($L = 1.8 \text{ mH}$; $R_L = 0 \text{ }\Omega$; $V_{bat} = 13.5 \text{ V}$; $T_{jstart} = 150 \text{ }^\circ\text{C}$; $I_L = 9 \text{ A}$) | 100 | mJ |
| P_{tot} | Power dissipation $T_C = 25 \text{ }^\circ\text{C}$ | 4.2 | W |
| T_j | Junction operating temperature | Internally limited | $^\circ\text{C}$ |
| T_c | Case operating temperature | - 40 to 150 | $^\circ\text{C}$ |
| T_{stg} | Storage temperature | - 55 to 150 | $^\circ\text{C}$ |

2.2 Thermal data

Table 4. Thermal data

| Symbol | Parameter | Max. value | Unit |
|----------------|-------------------------------------|-------------------|--------------------|
| $R_{thj-lead}$ | Thermal resistance junction-lead | 30 | $^\circ\text{C/W}$ |
| $R_{thj-amb}$ | Thermal resistance junction-ambient | 93 ⁽¹⁾ | $^\circ\text{C/W}$ |
| | | 82 ⁽²⁾ | $^\circ\text{C/W}$ |

1. When mounted on a standard single-sided FR-4 board with 0.5 cm^2 of Cu (at least $35 \text{ }\mu\text{m}$ thick) connected to all V_{CC} pins. Horizontal mounting and no artificial air flow.
2. When mounted on a standard single-sided FR-4 board with 2 cm^2 of Cu (at least $35 \text{ }\mu\text{m}$ thick) connected to all V_{CC} pins. Horizontal mounting and no artificial air flow.

2.3 Electrical characteristics

Values specified in this section are for $8\text{ V} < V_{CC} < 36\text{ V}$; $-40\text{ °C} < T_j < 150\text{ °C}$, unless otherwise stated.

Table 5. Electrical characteristics

| Symbol | Parameter | Test conditions | Min. | Typ. | Max. | Unit |
|--|----------------------------------|---|-------------------------------|------|------|------|
| Power | | | | | | |
| V_{CC} | Operating supply voltage | | 5.5 | 13 | 36 | V |
| V_{USD} | Undervoltage shutdown | | 3 | 4 | 5.5 | V |
| $V_{USDhyst}$ | Undervoltage shutdown hysteresis | | | 0.5 | | V |
| V_{OV} | Overvoltage shutdown | | 36 | | | V |
| R_{ON} | On-state resistance | $I_{OUT} = 2\text{ A}$; $T_j = 25\text{ °C}$; $V_{CC} > 8\text{ V}$ | | | 60 | mΩ |
| | | $I_{OUT} = 2\text{ A}$; $V_{CC} > 8\text{ V}$ | | | 120 | mΩ |
| I_S | Supply current | Off-state; $V_{CC} = 13\text{ V}$; $V_{IN} = V_{OUT} = 0\text{ V}$ | | 10 | 25 | μA |
| | | Off-state; $V_{CC} = 13\text{ V}$; $V_{IN} = V_{OUT} = 0\text{ V}$; $T_j = 25\text{ °C}$ | | 10 | 20 | μA |
| | | On-state; $V_{CC} = 13\text{ V}$; $V_{IN} = 5\text{ V}$; $I_{OUT} = 0\text{ A}$ | | 2 | 3.5 | mA |
| $I_{L(off1)}$ | Off-state output current | $V_{IN} = V_{OUT} = 0\text{ V}$ | 0 | | 50 | μA |
| $I_{L(off2)}$ | Off-state output current | $V_{IN} = 0\text{ V}$; $V_{OUT} = 3.5\text{ V}$ | -75 | | 0 | μA |
| $I_{L(off3)}$ | Off-state output current | $V_{IN} = V_{OUT} = 0\text{ V}$; $V_{CC} = 13\text{ V}$; $T_j = 125\text{ °C}$ | | | 5 | μA |
| $I_{L(off4)}$ | Off-state output current | $V_{IN} = V_{OUT} = 0\text{ V}$; $V_{CC} = 13\text{ V}$; $T_j = 25\text{ °C}$ | | | 3 | μA |
| Switching ($V_{CC} = 13\text{ V}$) | | | | | | |
| $t_{d(on)}$ | Turn-on delay time | $R_L = 6.5\text{ Ω}$ from V_{IN} rising edge to $V_{OUT} = 1.3\text{ V}$ | | 40 | | μs |
| $t_{d(off)}$ | Turn-off delay time | $R_L = 6.5\text{ Ω}$ from V_{IN} falling edge to $V_{OUT} = 11.7\text{ V}$ | | 30 | | μs |
| $dV_{OUT}/dt_{(on)}$ | Turn-on voltage slope | $R_L = 6.5\text{ Ω}$ from $V_{OUT} = 1.3\text{ V}$ to $V_{OUT} = 10.4\text{ V}$ | See Figure 21 | | | V/μs |
| $dV_{OUT}/dt_{(off)}$ | Turn-off voltage slope | $R_L = 6.5\text{ Ω}$ from $V_{OUT} = 11.7\text{ V}$ to $V_{OUT} = 1.3\text{ V}$ | See Figure 22 | | | V/μs |
| Input pin | | | | | | |
| V_{IL} | Input low level | | | | 1.25 | V |
| I_{IL} | Low level input current | $V_{IN} = 1.25\text{ V}$ | 1 | | | μA |
| V_{IH} | Input high level | | 3.25 | | | V |

Table 5. Electrical characteristics (continued)

| Symbol | Parameter | Test conditions | Min. | Typ. | Max. | Unit |
|---|---|---|-------------|-------------|-------------|------------------|
| I_{IH} | High level input current | $V_{IN} = 3.25\text{ V}$ | | | 10 | μA |
| V_{hyst} | Input hysteresis voltage | | 0.5 | | | V |
| V_{ICL} | Input clamp voltage | $I_{IN} = 1\text{ mA}$ | 6 | 6.8 | 8 | V |
| | | $I_{IN} = -1\text{ mA}$ | | -0.7 | | V |
| V_{CC} output diode | | | | | | |
| V_F | Forward on voltage | $-I_{OUT} = 1.3\text{ A}; T_j = 150\text{ }^\circ\text{C}$ | | | 0.6 | V |
| Status pin | | | | | | |
| V_{STAT} | Status low output voltage | $I_{STAT} = 1.6\text{ mA}$ | | | 0.5 | V |
| I_{LSTAT} | Status leakage current | Normal operation; $V_{STAT} = 5\text{ V}$ | | | 10 | μA |
| C_{STAT} | Status pin input capacitance | Normal operation; $V_{STAT} = 5\text{ V}$ | | | 100 | pF |
| V_{SCL} | Status clamp voltage | $I_{STAT} = 1\text{ mA}$ | 6 | 6.8 | 8 | V |
| | | $I_{STAT} = -1\text{ mA}$ | | -0.7 | | V |
| Protections⁽¹⁾ | | | | | | |
| T_{TSD} | Shutdown temperature | | 150 | 175 | 200 | $^\circ\text{C}$ |
| T_R | Reset temperature | | 135 | | | $^\circ\text{C}$ |
| T_{hyst} | Thermal hysteresis | | 7 | 15 | | $^\circ\text{C}$ |
| t_{SDL} | Status delay in overload condition | $T_j > T_{jsh}$ | | | 20 | ms |
| I_{lim} | Current limitation | $9\text{ V} < V_{CC} < 36\text{ V}$ | 6 | 9 | 15 | A |
| | | $5\text{ V} < V_{CC} < 36\text{ V}$ | | | 15 | A |
| V_{demag} | Turn-off output clamp voltage | $I_{OUT} = 2\text{ A}; V_{IN} = 0\text{ V};$ $L = 6\text{ mH}$ | $V_{CC}-41$ | $V_{CC}-48$ | $V_{CC}-55$ | V |
| Open-load detection | | | | | | |
| I_{OL} | Open-load on-state detection threshold | $V_{IN} = 5\text{ V}$ | 50 | | 200 | mA |
| $t_{DOL(on)}$ | Open-load on-state detection delay | $I_{OUT} = 0\text{ A}$ | | | 200 | μs |
| V_{OL} | Open-load off-state voltage detection threshold | $V_{IN} = 0\text{ V}$ | 1.5 | | 3.5 | V |
| $t_{DOL(off)}$ | Open-load detection delay at turn-off | | | | 1000 | μs |

1. To ensure long term reliability under heavy overload or short circuit conditions, protection and related diagnostic signals must be used together with a proper software strategy. If the device operates under abnormal conditions this software must limit the duration and number of activation cycles.

Figure 4. Status timings

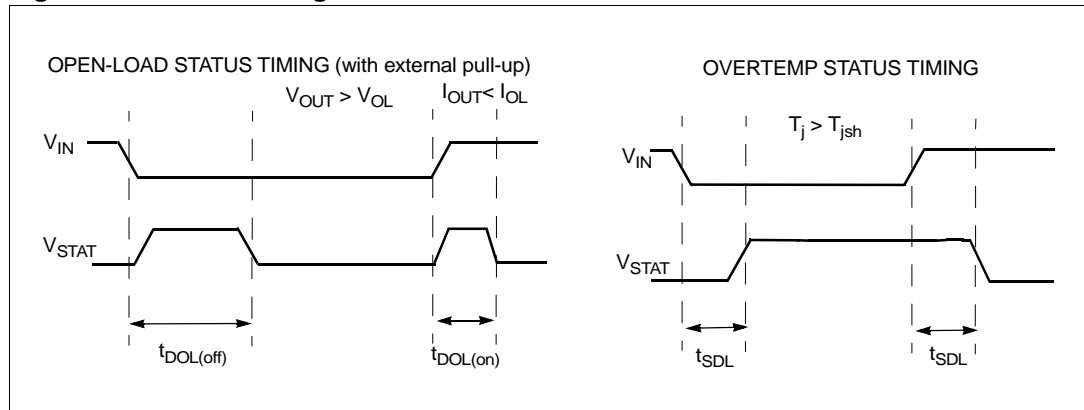

Figure 5. Switching time waveforms

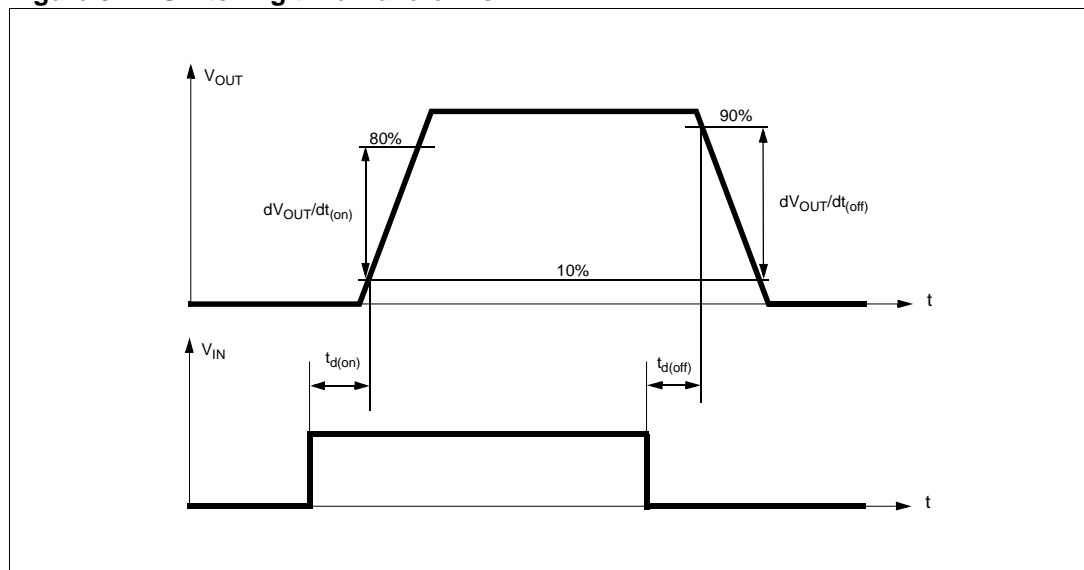

Table 6. Truth table

| Conditions | Input | Output | Status |
|--------------------|-------|--------|--|
| Normal operation | L | L | H |
| | H | H | H |
| Current limitation | L | L | H |
| | H | X | $(T_j < T_{TSD})$ H $(T_j > T_{TSD})$ L |
| Over temperature | L | L | H |
| | H | L | L |
| Undervoltage | L | L | X |
| | H | L | X |
| Overvoltage | L | L | H |
| | H | L | H |

Table 6. Truth table (continued)

| Conditions | Input | Output | Status |
|---------------------------|-------|--------|--------|
| Output voltage > V_{OL} | L | H | L |
| | H | H | H |
| Output current < I_{OL} | L | L | H |
| | H | H | L |

Table 7. Electrical transient requirements on V_{CC} pin (part 1/3)

| ISO T/R 7637/1 test pulse | Test levels | | | | Delays and impedance |
|---------------------------|-------------|---------|---------|---------|-------------------------|
| | I | II | III | IV | |
| 1 | -25 V | -50 V | -75 V | -100 V | 2 ms 10 Ω |
| 2 | +25 V | +50 V | +75 V | +100 V | 0.2 ms 10 Ω |
| 3a | -25 V | -50 V | -100 V | -150 V | 0.1 μ s 50 Ω |
| 3b | +25 V | +50 V | +75 V | +100 V | 0.1 μ s 50 Ω |
| 4 | -4 V | -5 V | -6 V | -7 V | 100 ms, 0.01 Ω |
| 5 | +26.5 V | +46.5 V | +66.5 V | +86.5 V | 400 ms, 2 Ω |

Table 8. Electrical transient requirements on V_{CC} pin (part 2/3)

| ISO T/R 7637/1 test pulse | Test levels results | | | |
|---------------------------|---------------------|----|-----|----|
| | I | II | III | IV |
| 1 | C | C | C | C |
| 2 | C | C | C | C |
| 3a | C | C | C | C |
| 3b | C | C | C | C |
| 4 | C | C | C | C |
| 5 | C | E | E | E |

Table 9. Electrical transient requirements on V_{CC} pin (part 3/3)

| Class | Contents |
|-------|---|
| C | All functions of the device are performed as designed after exposure to disturbance. |
| E | One or more functions of the device is not performed as designed after exposure to disturbance and cannot be returned to proper operation without replacing the device. |

Figure 6. Waveforms

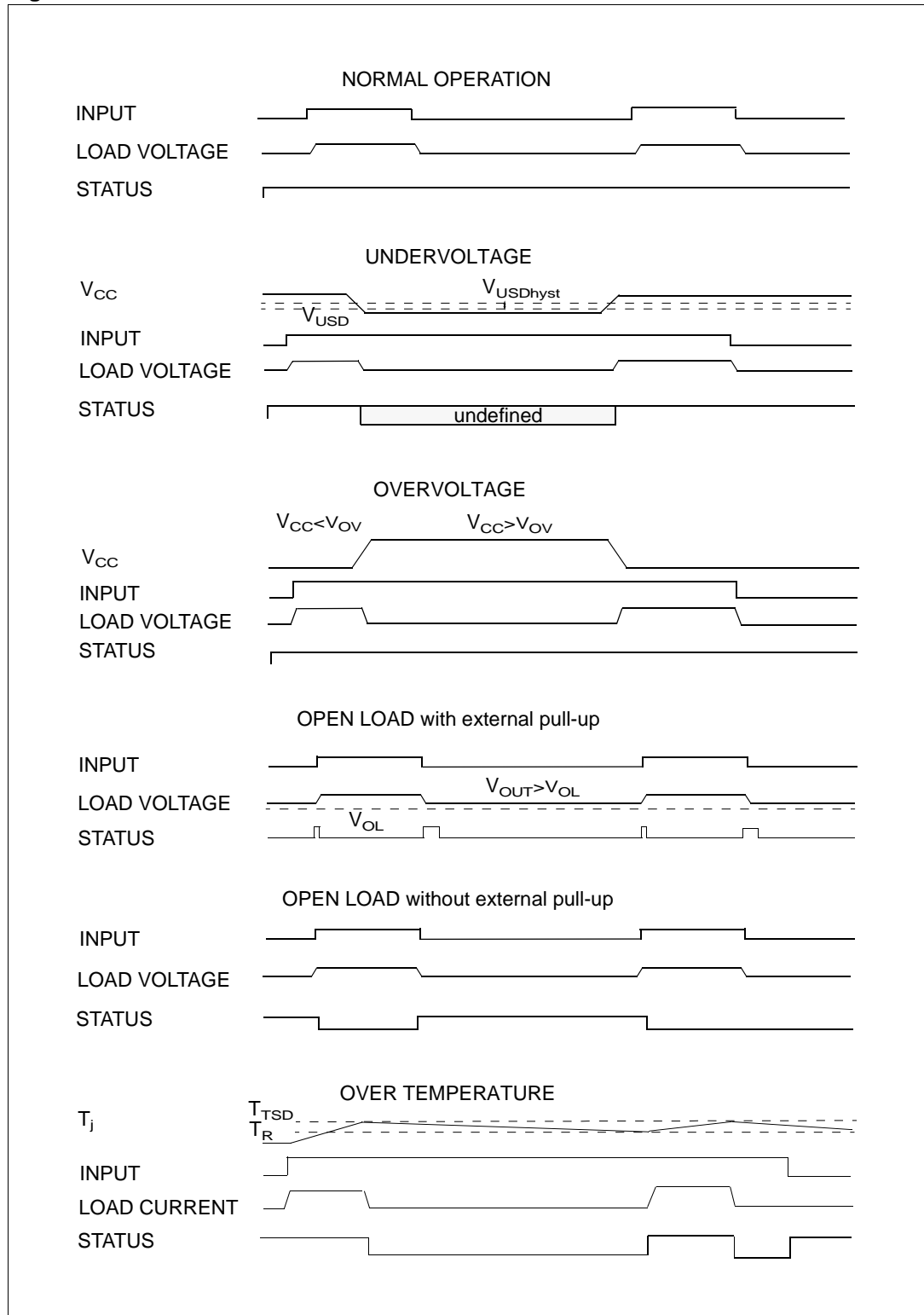

2.4 Electrical characteristics curves

Figure 7. Off-state output current

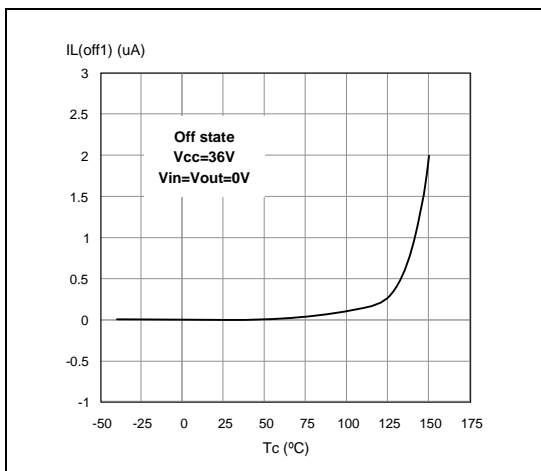

Figure 8. High level input current

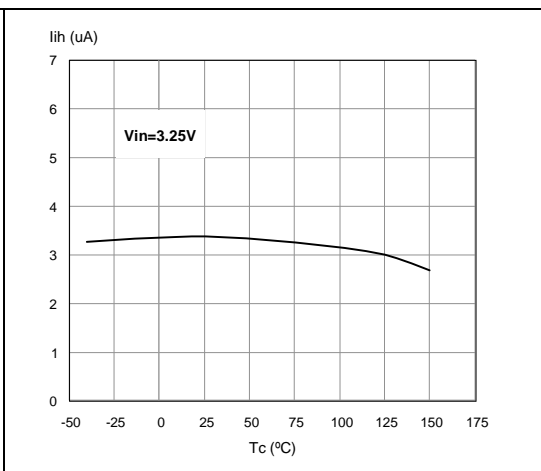

Figure 9. Input clamp voltage

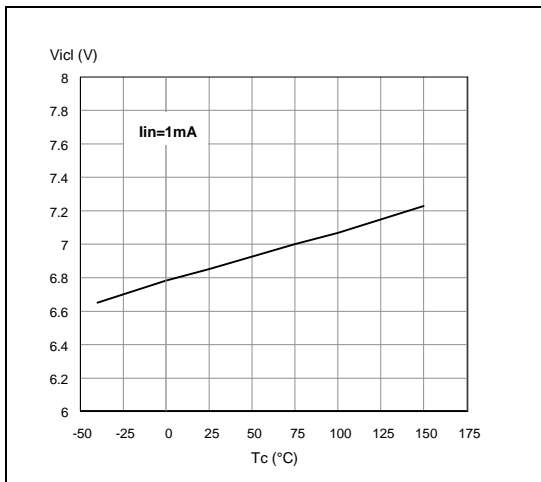

Figure 10. Status leakage current

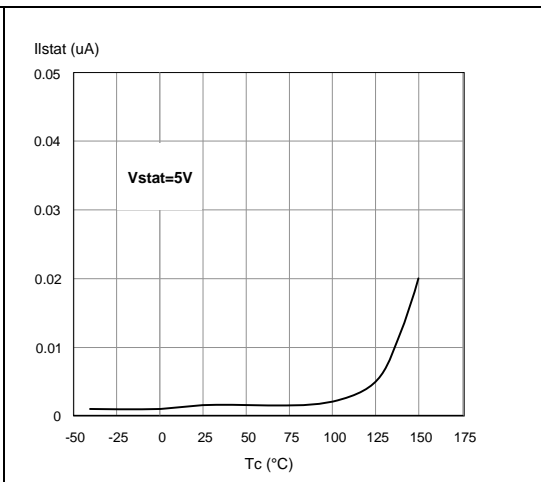

Figure 11. Status low output voltage

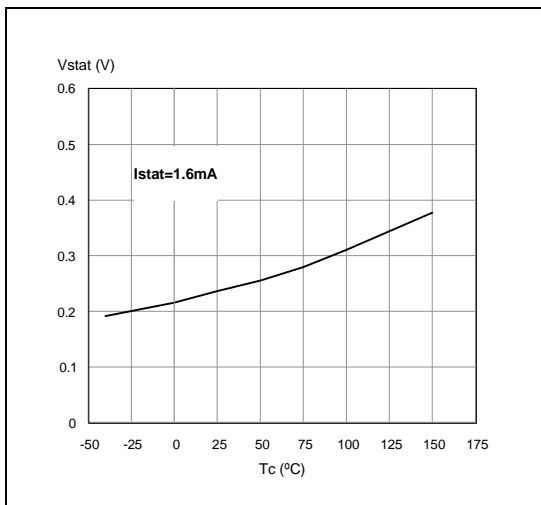

Figure 12. Status clamp voltage

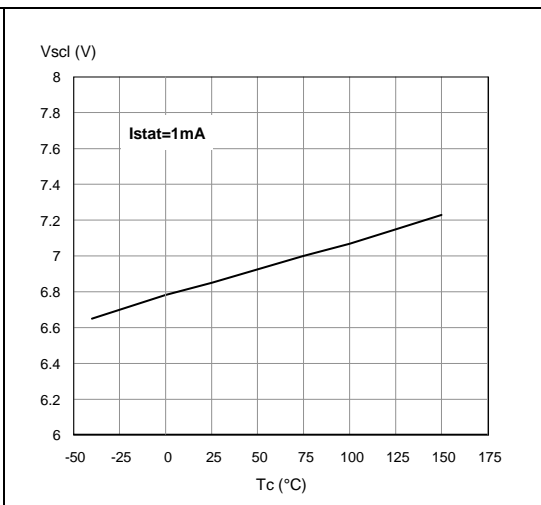

Figure 13. On-state resistance vs T_{case}

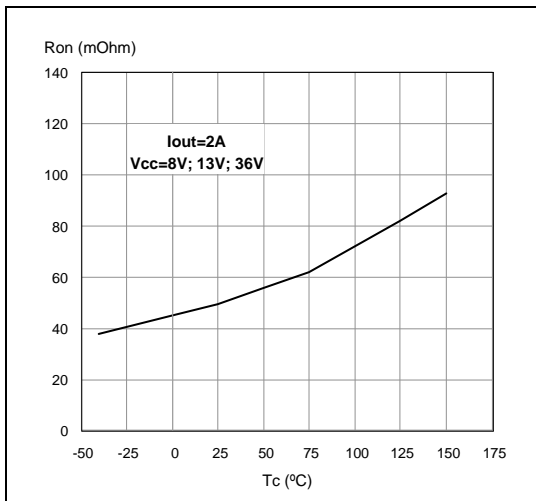

Figure 14. On-state resistance vs V_{CC}

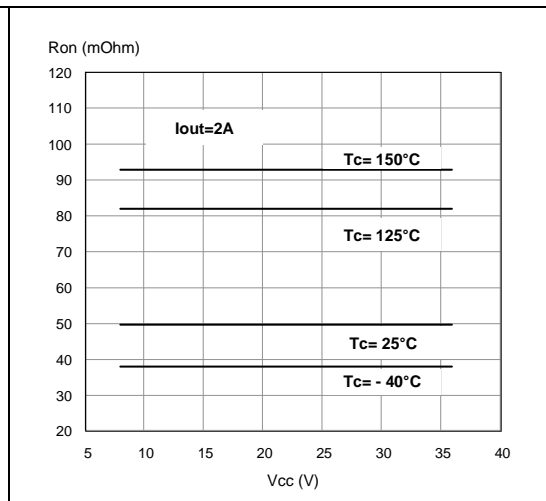

Figure 15. Open-load on-state detection threshold

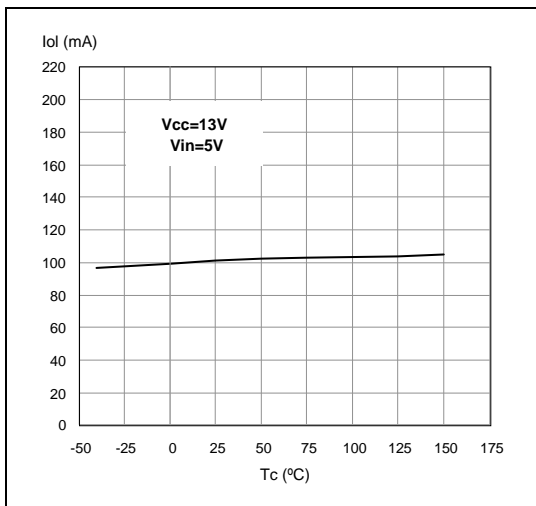

Figure 16. Input high level

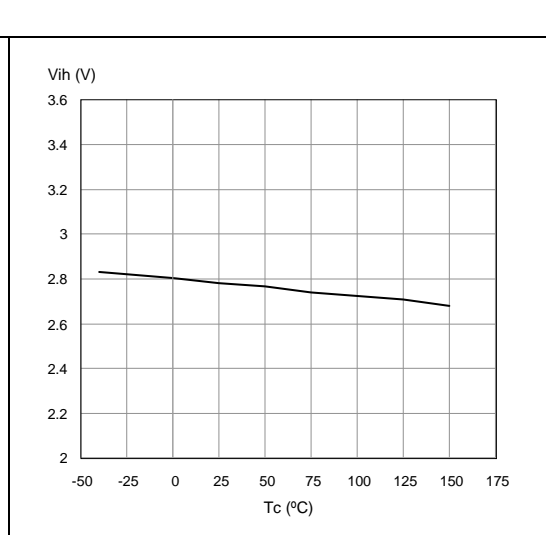

Figure 17. Input low level

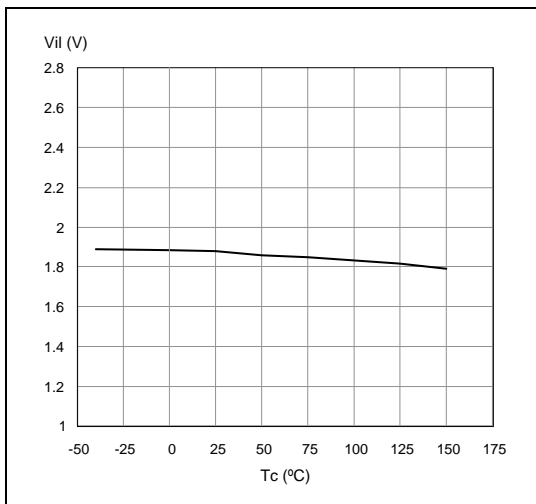

Figure 18. Input hysteresis voltage

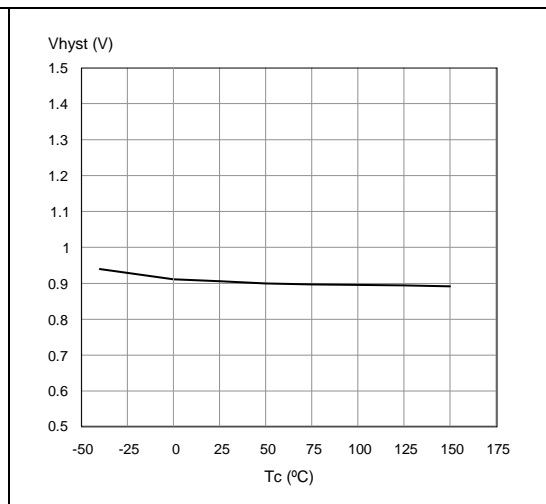

Figure 19. Overvoltage shutdown

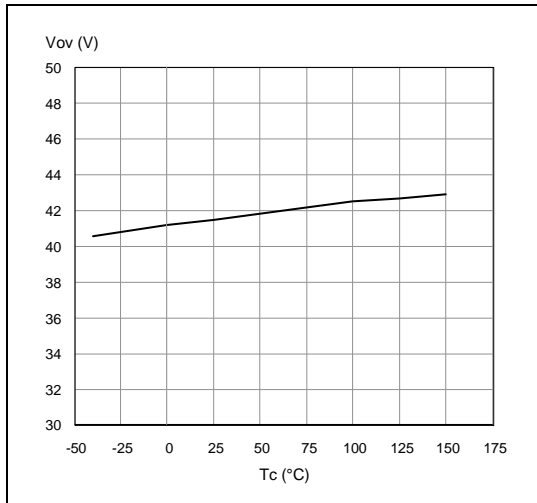

Figure 20. Open-load off-state voltage detection threshold

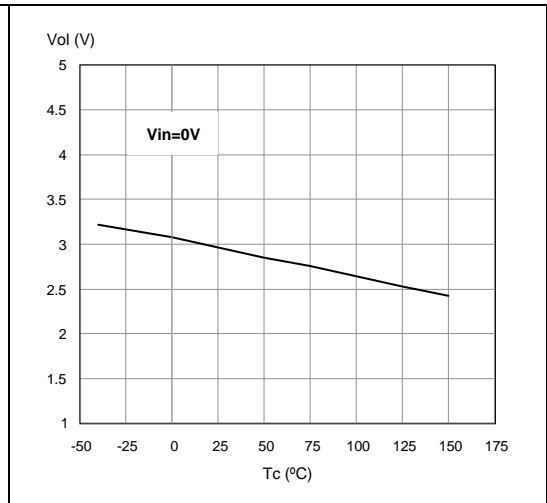

Figure 21. Turn-on voltage slope

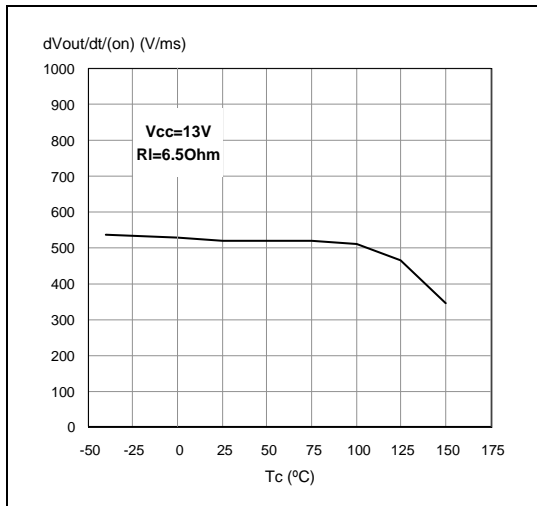

Figure 22. Turn-off voltage slope

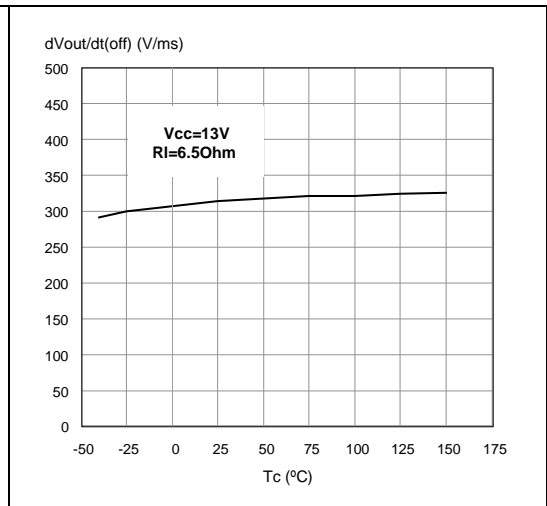

Figure 23. Ilim vs Tcase

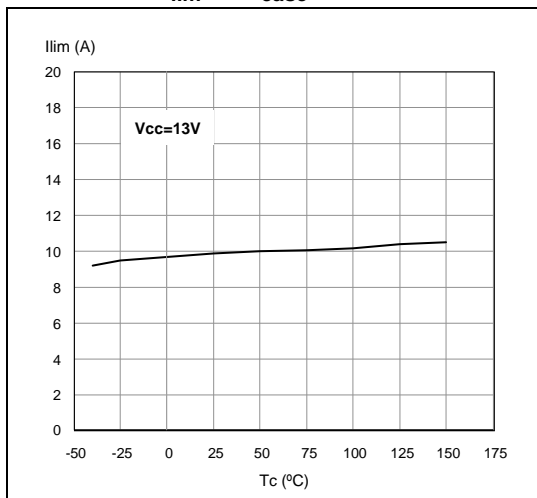
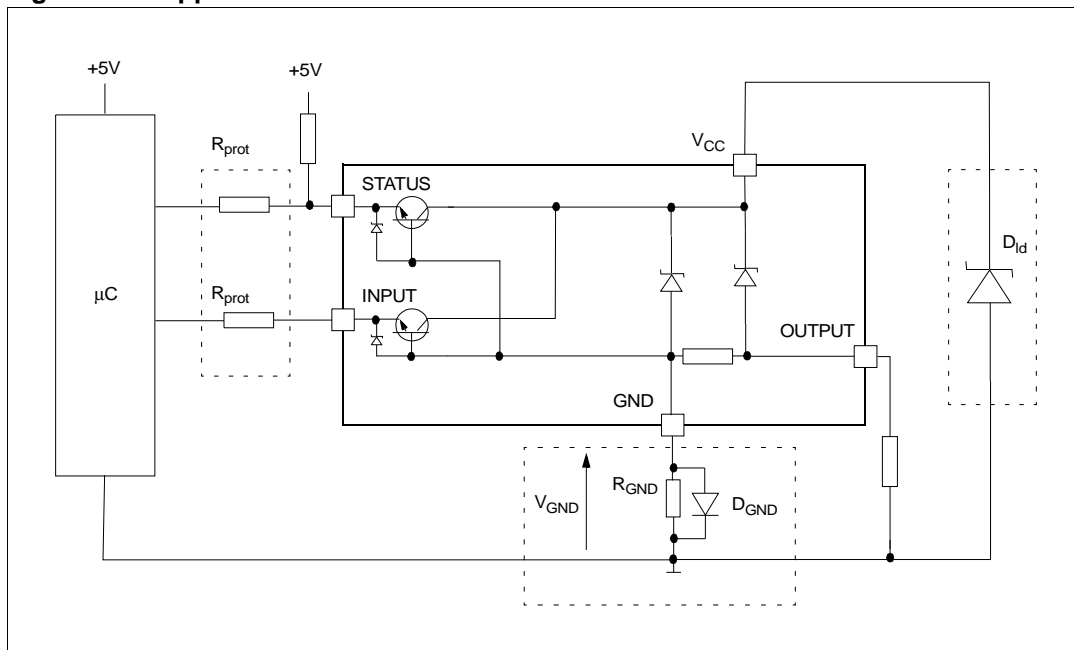

Figure 24. Application schematic



2.5 GND protection network against reverse battery

Solution 1: resistor in the ground line (R_{GND} only). This can be used with any type of load.

The following is an indication on how to dimension the R_{GND} resistor.

1. $R_{GND} \leq 600 \text{ mV} / (I_{S(on)max})$.
2. $R_{GND} \geq (-V_{CC}) / (-I_{GND})$

where $-I_{GND}$ is the DC reverse ground pin current and can be found in the absolute maximum rating section of the device datasheet.

Power dissipation in R_{GND} (when $V_{CC} < 0$: during reverse battery situations) is:

$$P_D = (-V_{CC})^2 / R_{GND}$$

This resistor can be shared amongst several different HSDs. Please note that the value of this resistor should be calculated with formula (1) where $I_{S(on)max}$ becomes the sum of the maximum on-state currents of the different devices.

Please note that if the microprocessor ground is not shared by the device ground then the R_{GND} produces a shift ($I_{S(on)max} * R_{GND}$) in the input thresholds and the status output values. This shift varies depending on how many devices are on in the case of several high side drivers sharing the same R_{GND} .

If the calculated power dissipation leads to a large resistor or several devices have to share the same resistor then ST suggests to utilize solution 2 (see below).

Solution 2: diode (D_{GND}) in the ground line A resistor ($R_{GND} = 1 \text{ k}\Omega$) should be inserted in parallel to D_{GND} if the device drives an inductive load.

This small signal diode can be safely shared amongst several different HSDs. Also in this case, the presence of the ground network will produce a shift ($\approx 600 \text{ mV}$) in the input threshold and in the status output values if the microprocessor ground is not common to the

device ground. This shift will not vary if more than one HSD shares the same diode/resistor network.

Series resistor in input and status lines are also required to prevent that, during battery voltage transient, the current exceeds the absolute maximum rating.

Safest configuration for unused input and status pin is to leave them unconnected.

2.6 Load dump protection

D_{ld} is necessary (voltage transient suppressor) if the load dump peak voltage exceeds the V_{CC} max DC rating. The same applies if the device is subject to transients on the V_{CC} line that are greater than the ones shown in the ISO 7637-2: 2004(E) table.

2.7 Microcontroller I/Os protection

If a ground protection network is used and negative transient are present on the V_{CC} line, the control pins will be pulled negative. ST suggests to insert a resistor (R_{prot}) in line to prevent the microcontroller I/O pins to latch-up.

The value of these resistors is a compromise between the leakage current of microcontroller and the current required by the HSD I/Os (Input levels compatibility) with the latch-up limit of microcontroller I/Os.

$$-V_{CCpeak}/I_{latchup} \leq R_{prot} \leq (V_{OH\mu C} - V_{IH} - V_{GND}) / I_{IHmax}$$

Calculation example:

For $V_{CCpeak} = -100$ V and $I_{latchup} \geq 20$ mA; $V_{OH\mu C} \geq 4.5$ V

$$5 \text{ k}\Omega \leq R_{prot} \leq 65 \text{ k}\Omega$$

Recommended values: $R_{prot} = 10 \text{ k}\Omega$.

2.8 Open-load detection in off-state

Off-state open-load detection requires an external pull-up resistor (R_{PU}) connected between output pin and a positive supply voltage (V_{PU}) like the +5V line used to supply the microprocessor.

The external resistor has to be selected according to the following requirements:

- no false open-load indication when load is connected: in this case we have to avoid V_{OUT} to be higher than V_{OLmin} ; this results in the following condition $V_{OUT} = (V_{PU} / (R_L + R_{PU}))R_L < V_{OLmin}$.
- no misdetection when load is disconnected: in this case the V_{OUT} has to be higher than V_{OLmax} ; this results in the following condition $R_{PU} < (V_{PU} - V_{OLmax}) / I_{L(off2)}$.

Because $I_{s(OFF)}$ may significantly increase if V_{out} is pulled high (up to several mA), the pull-up resistor R_{PU} should be connected to a supply that is switched off when the module is in standby.

The values of V_{OLmin} , V_{OLmax} and $I_{L(off2)}$ are available in the electrical characteristics section.

Figure 25. Open-load detection in off-state

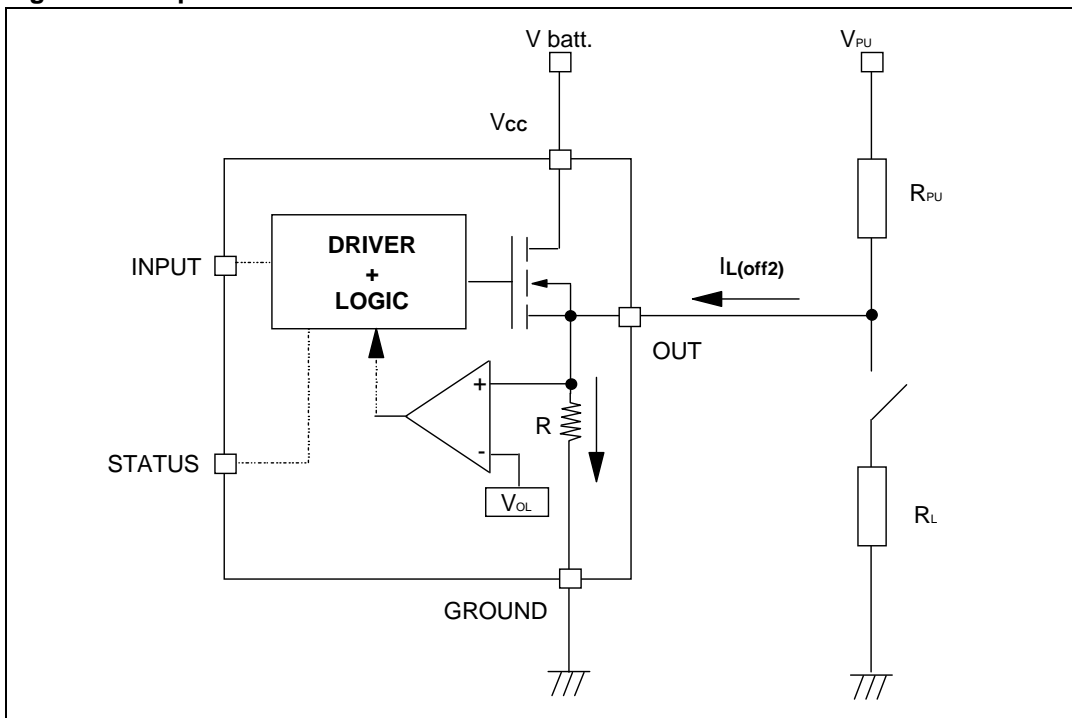

2.9 SO-8 maximum demagnetization energy ($V_{CC} = 13.5\text{ V}$)

Figure 26. SO-8 maximum turn-off current versus inductance

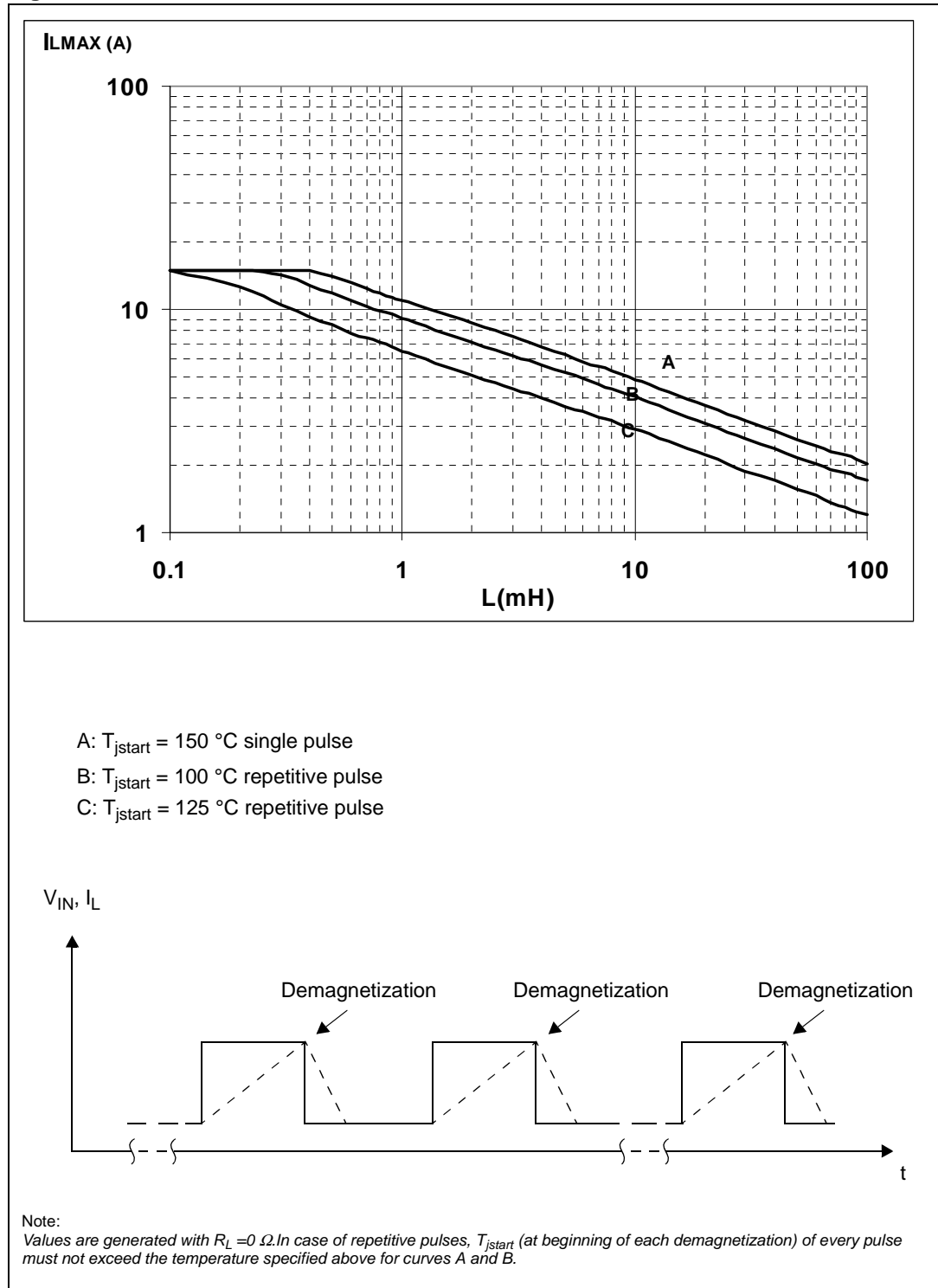

3 Package and PCB thermal data

3.1 SO-8 thermal data

Figure 27. PC board

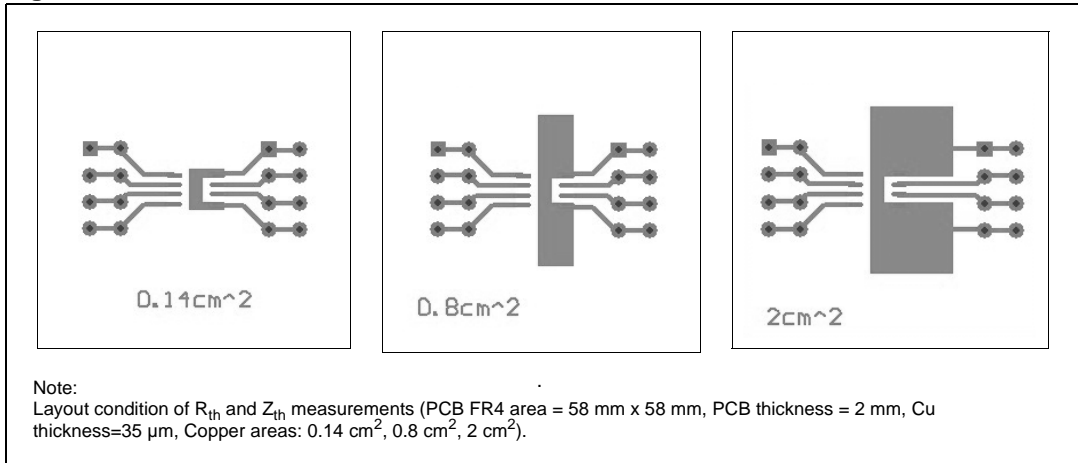

Figure 28. $R_{thj-amb}$ vs PCB copper area in open box free air condition

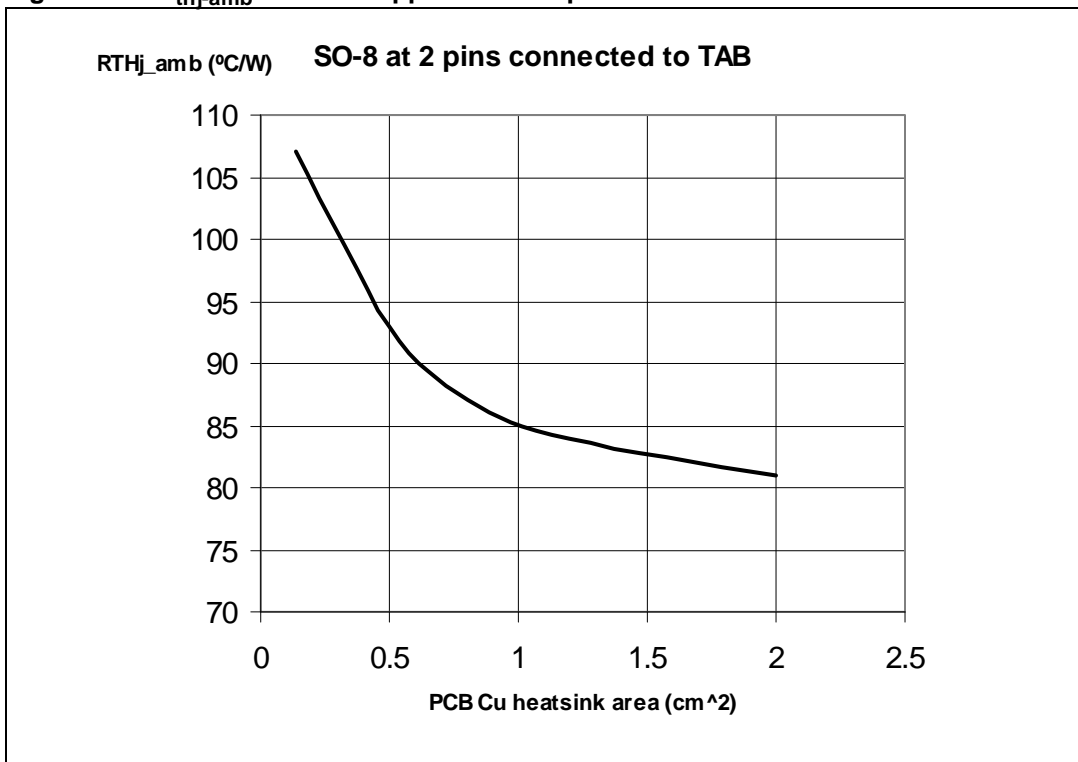
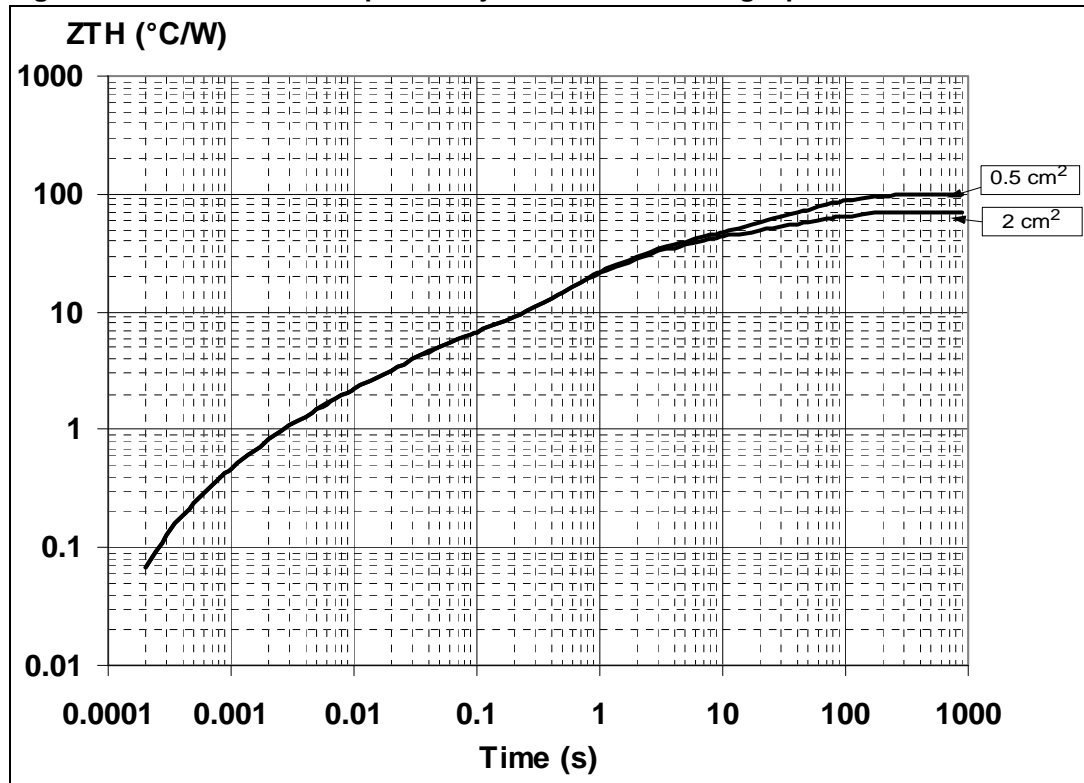

Figure 29. SO-8 thermal impedance junction ambient single pulse



Equation 1: pulse calculation formula

$$Z_{TH\delta} = R_{TH} \cdot \delta + Z_{THtp}(1 - \delta)$$

where $\delta = t_p/T$

Figure 30. Thermal fitting model of a single channel

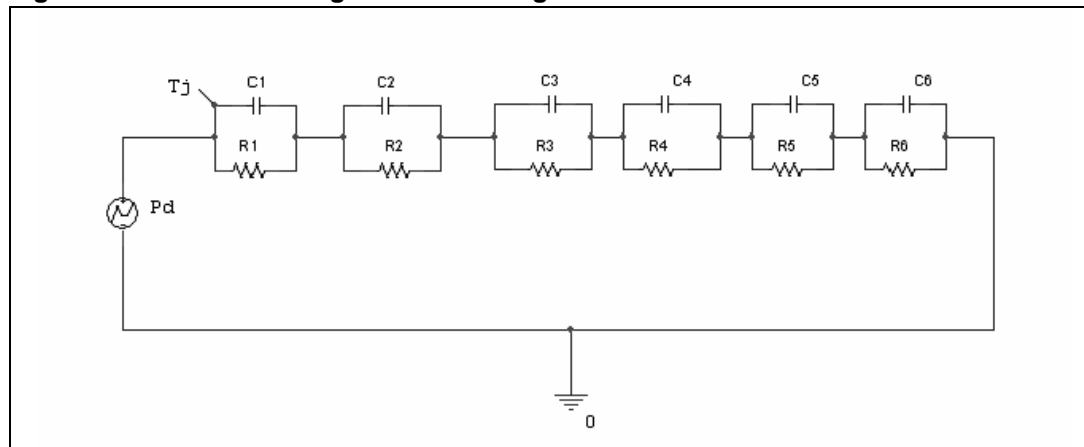

Table 10. Thermal parameter

| Area/island (cm ²) | 0.5 | 2 |
|--------------------------------|--------|----|
| R1 (°C/W) | 0.05 | |
| R2 (°C/W) | 0.8 | |
| R3 (°C/W) | 3.5 | |
| R4 (°C/W) | 21 | |
| R5 (°C/W) | 16 | |
| R6 (°C/W) | 58 | 28 |
| C1 (W·s/°C) | 0.006 | |
| C2 (W·s/°C) | 0.0026 | |
| C3 (W·s/°C) | 0.0075 | |
| C4 (W·s/°C) | 0.045 | |
| C5 (W·s/°C) | 0.35 | |
| C6 (W·s/°C) | 1.05 | 2 |

4 Package and packing information

In order to meet environmental requirements, ST offers these devices in different grades of ECOPACK® packages, depending on their level of environmental compliance. ECOPACK® specifications, grade definitions and product status are available at: www.st.com.

ECOPACK® is an ST trademark.

4.1 SO-8 package information

Figure 31. SO-8 package dimensions

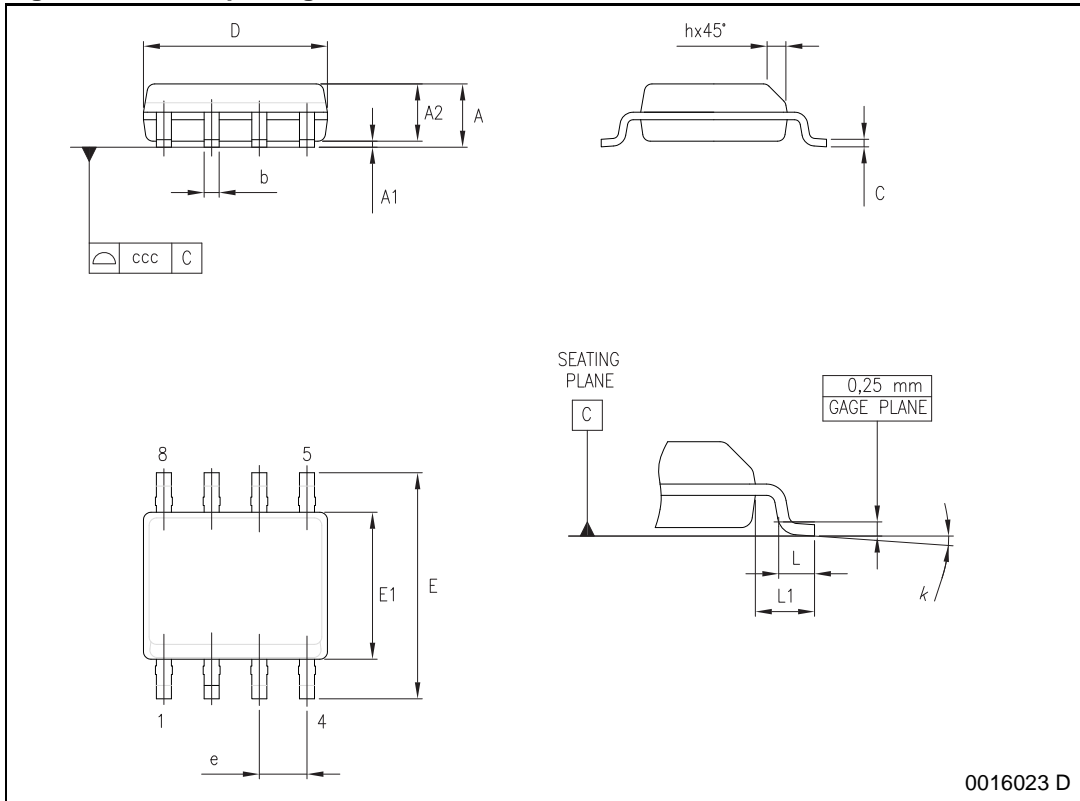

Table 11. SO-8 mechanical data

| Dim. | mm | | |
|-------------------|------|------|------|
| | Min. | Typ. | Max. |
| A | | | 1.75 |
| A1 | 0.10 | | 0.25 |
| A2 | 1.25 | | |
| b | 0.28 | | 0.48 |
| c | 0.17 | | 0.23 |
| D ⁽¹⁾ | 4.80 | 4.90 | 5.00 |
| E | 5.80 | 6.00 | 6.20 |
| E1 ⁽²⁾ | 3.80 | 3.90 | 4.00 |
| e | | 1.27 | |
| h | 0.25 | | 0.50 |
| L | 0.40 | | 1.27 |
| L1 | | 1.04 | |
| k | 0° | | 8° |
| ccc | | | 0.10 |

1. Dimension "D" does not include mold flash, protrusions or gate burrs. Mold flash, protrusions or gate burrs shall not exceed 0.15 mm in total (both side).
2. Dimension "E1" does not include interlead flash or protrusions. Interlead flash or protrusions shall not exceed 0.25 mm per side.

4.2 SO-8 packing information

The devices can be packed in tube or tape and reel shipments (see the [Device summary on page 1](#)).

Figure 32. SO-8 tube shipment (no suffix)

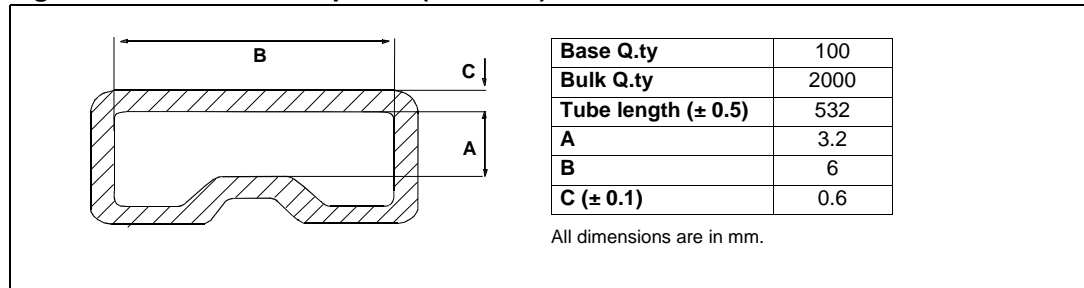
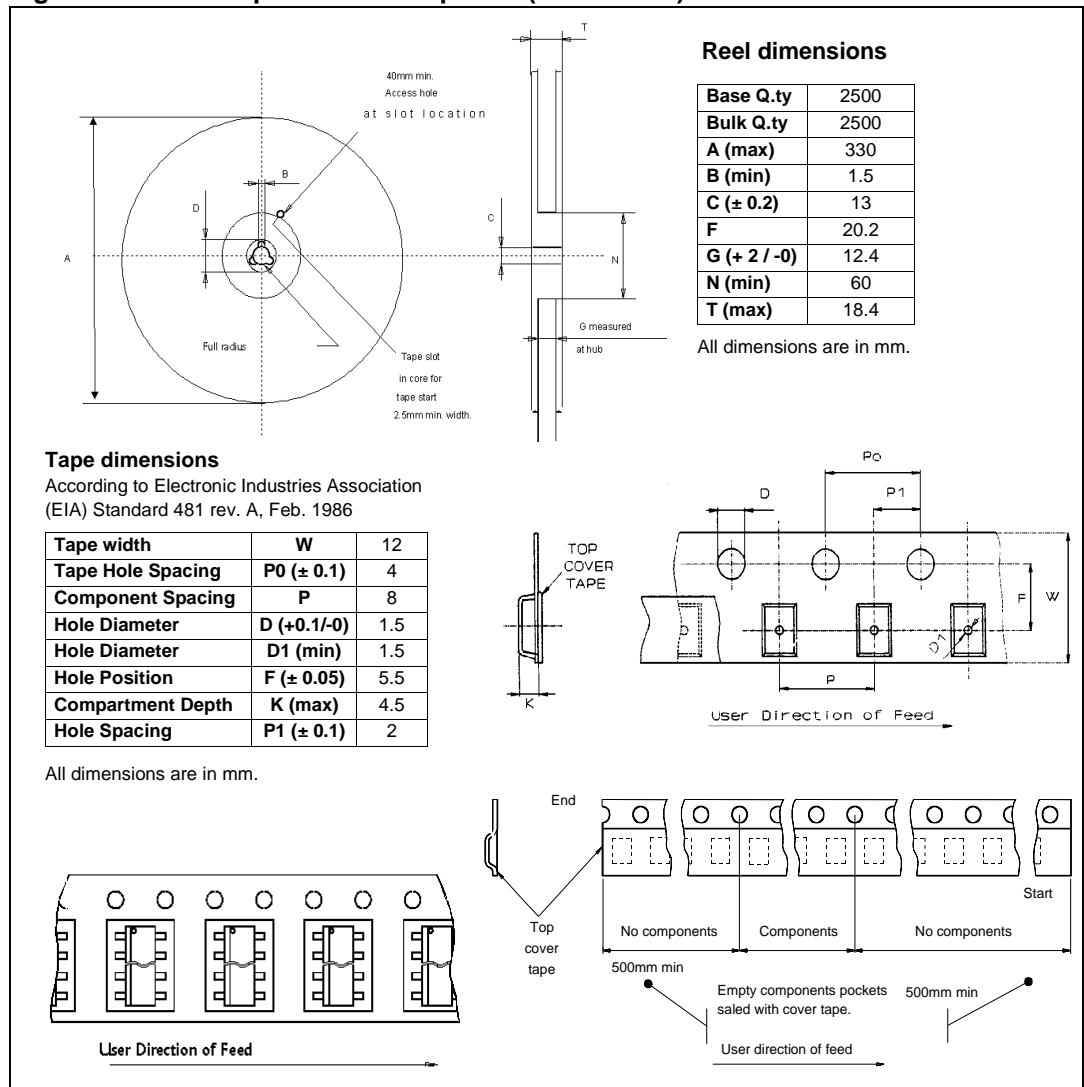

Figure 33. SO-8 tape and reel shipment (suffix “TR”)



5 Revision history

Table 12. Document revision history

| Date | Revision | Changes |
|-------------|----------|--|
| 23-Nov-2009 | 1 | Initial release. |
| 15-Oct-2010 | 2 | Updated Table 4: Thermal data Updated following figure titles: – Figure 21: Turn-on voltage slope – Figure 22: Turn-off voltage slope |
| 19-Sep-2013 | 3 | Updated Disclaimer. |

Please Read Carefully:

Information in this document is provided solely in connection with ST products. STMicroelectronics NV and its subsidiaries ("ST") reserve the right to make changes, corrections, modifications or improvements, to this document, and the products and services described herein at any time, without notice.

All ST products are sold pursuant to ST's terms and conditions of sale.

Purchasers are solely responsible for the choice, selection and use of the ST products and services described herein, and ST assumes no liability whatsoever relating to the choice, selection or use of the ST products and services described herein.

No license, express or implied, by estoppel or otherwise, to any intellectual property rights is granted under this document. If any part of this document refers to any third party products or services it shall not be deemed a license grant by ST for the use of such third party products or services, or any intellectual property contained therein or considered as a warranty covering the use in any manner whatsoever of such third party products or services or any intellectual property contained therein.

UNLESS OTHERWISE SET FORTH IN ST'S TERMS AND CONDITIONS OF SALE ST DISCLAIMS ANY EXPRESS OR IMPLIED WARRANTY WITH RESPECT TO THE USE AND/OR SALE OF ST PRODUCTS INCLUDING WITHOUT LIMITATION IMPLIED WARRANTIES OF MERCHANTABILITY, FITNESS FOR A PARTICULAR PURPOSE (AND THEIR EQUIVALENTS UNDER THE LAWS OF ANY JURISDICTION), OR INFRINGEMENT OF ANY PATENT, COPYRIGHT OR OTHER INTELLECTUAL PROPERTY RIGHT.

ST PRODUCTS ARE NOT DESIGNED OR AUTHORIZED FOR USE IN: (A) SAFETY CRITICAL APPLICATIONS SUCH AS LIFE SUPPORTING, ACTIVE IMPLANTED DEVICES OR SYSTEMS WITH PRODUCT FUNCTIONAL SAFETY REQUIREMENTS; (B) AERONAUTIC APPLICATIONS; (C) AUTOMOTIVE APPLICATIONS OR ENVIRONMENTS, AND/OR (D) AEROSPACE APPLICATIONS OR ENVIRONMENTS. WHERE ST PRODUCTS ARE NOT DESIGNED FOR SUCH USE, THE PURCHASER SHALL USE PRODUCTS AT PURCHASER'S SOLE RISK, EVEN IF ST HAS BEEN INFORMED IN WRITING OF SUCH USAGE, UNLESS A PRODUCT IS EXPRESSLY DESIGNATED BY ST AS BEING INTENDED FOR "AUTOMOTIVE, AUTOMOTIVE SAFETY OR MEDICAL" INDUSTRY DOMAINS ACCORDING TO ST PRODUCT DESIGN SPECIFICATIONS. PRODUCTS FORMALLY ESCC, QML OR JAN QUALIFIED ARE DEEMED SUITABLE FOR USE IN AEROSPACE BY THE CORRESPONDING GOVERNMENTAL AGENCY.

Resale of ST products with provisions different from the statements and/or technical features set forth in this document shall immediately void any warranty granted by ST for the ST product or service described herein and shall not create or extend in any manner whatsoever, any liability of ST.

ST and the ST logo are trademarks or registered trademarks of ST in various countries.

Information in this document supersedes and replaces all information previously supplied.

The ST logo is a registered trademark of STMicroelectronics. All other names are the property of their respective owners.

© 2013 STMicroelectronics - All rights reserved

STMicroelectronics group of companies

Australia - Belgium - Brazil - Canada - China - Czech Republic - Finland - France - Germany - Hong Kong - India - Israel - Italy - Japan - Malaysia - Malta - Morocco - Philippines - Singapore - Spain - Sweden - Switzerland - United Kingdom - United States of America

www.st.com

Looking for pricing, stock, or lifecycle information?

Click below to explore more details on WIN SOURCE:

-  [View VN750PSTR-E on WIN SOURCE](#)
-  [STMicroelectronics](#) Information

Optimize Your Supply Chain with WIN SOURCE Solutions

-  Global Sourcing Solution
-  Obsolete Management
-  Cost Control Management
-  Shortage Management
-  Alternative Solution
-  Excess Inventory Management