



**THE DATASHEET OF
VN330SPTR-E**



Quad high-side smart power solid-state relay

Datasheet - production data

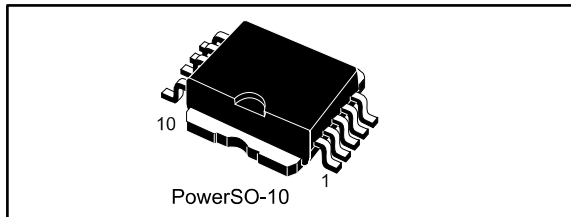

- Open drain diagnostic output
- Fast demagnetization of inductive loads
- Conforms to IEC 61131-2

Description

The VN330SP-E is a monolithic device developed using the VIPower technology, intended to drive four independent resistive or inductive loads with one side connected to ground. Active current limitation prevents dropping of the system power supply in case of shorted load. Built-in thermal shutdown protects the chip from overtemperature and short-circuit. The open drain diagnostic output indicates overtemperature conditions.

Features

Type	V _{demag} ⁽¹⁾	R _{DS(on)} ⁽²⁾	I _{out} ⁽¹⁾	V _{CC}
VN330SP-E	V _{CC} -55 V	0.32 Ω	0.7 A	36 V

Notes:

⁽¹⁾Per channel

⁽²⁾At T_J = 85 °C

- Output current: 0.7 A per channel
- Digital input clamped at 32 V minimum voltage
- Shorted load and overtemperature protections
- Built-in current limiter
- Undervoltage shutdown

Table 1: Device summary

Order code	Package	Packing
VN330SP-E	PowerSO-10	Tube
VN330SPTR-E		Tape and reel

Contents

1	Block diagram.....	5
2	Pin connection.....	6
3	Maximum ratings	7
4	Electrical characteristics	8
5	Test circuits	11
6	Switching time waveforms and truth table	12
7	Package information	14
	7.1 PowerSO-10 package information	14
	7.2 PowerSO-10 packing information.....	16
8	Revision history	19

List of tables

Table 1: Device summary	1
Table 2: Absolute maximum ratings	7
Table 3: Thermal data.....	7
Table 4: Power section	8
Table 5: Switching (VCC = 24 V)	8
Table 6: Logic inputs.....	9
Table 7: Protection and diagnostic	10
Table 8: Truth table.....	12
Table 9: PowerSO-10 package mechanical data	15
Table 10: PowerSO-10 carrier tape dimension mechanical data	16
Table 11: PowerSO-10 reel dimension mechanical data	17
Table 12: PowerSO-10 base and bulk quantity in tape and reel	17
Table 13: Document revision history	19

List of figures

Figure 1: Block diagram	5
Figure 2: Connection diagram (top view)	6
Figure 3: Current and voltage conventions	6
Figure 4: Avalanche energy test circuit	11
Figure 5: Peak short-circuit test diagram	11
Figure 6: Switching waveforms	12
Figure 7: Switching parameter test conditions	13
Figure 8: Driving circuit	13
Figure 9: PowerSO-10 package outline	14
Figure 10: PowerSO-10 carrier tape outline	16
Figure 11: PowerSO-10 reel outline	17
Figure 12: PowerSO-10 suggested pad and tube shipment (no suffix)	18

1 Block diagram

Figure 1: Block diagram

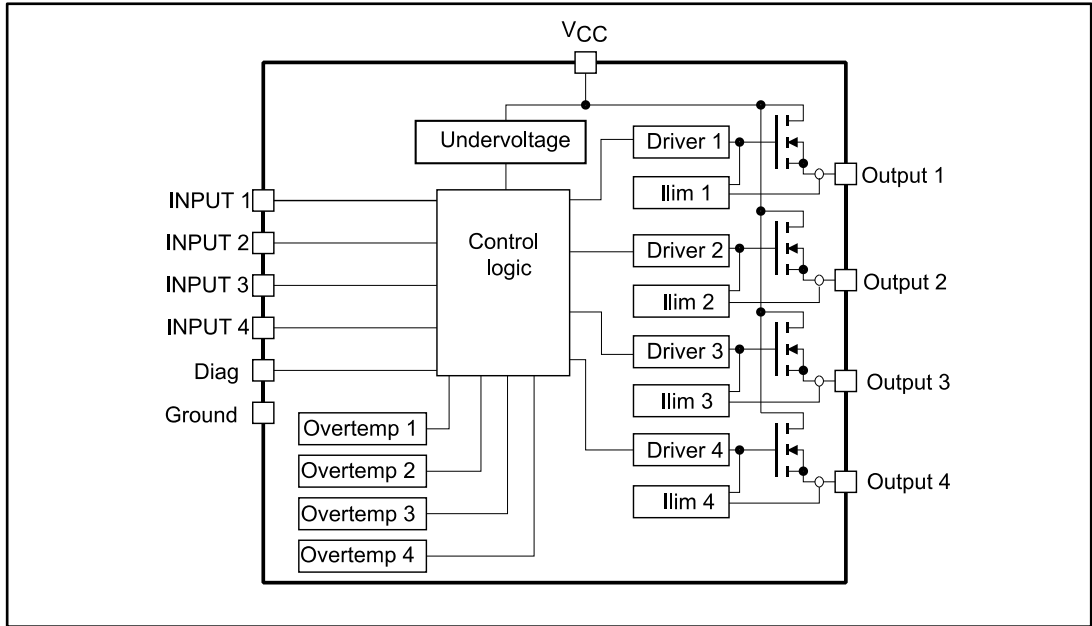

2 Pin connection

Figure 2: Connection diagram (top view)

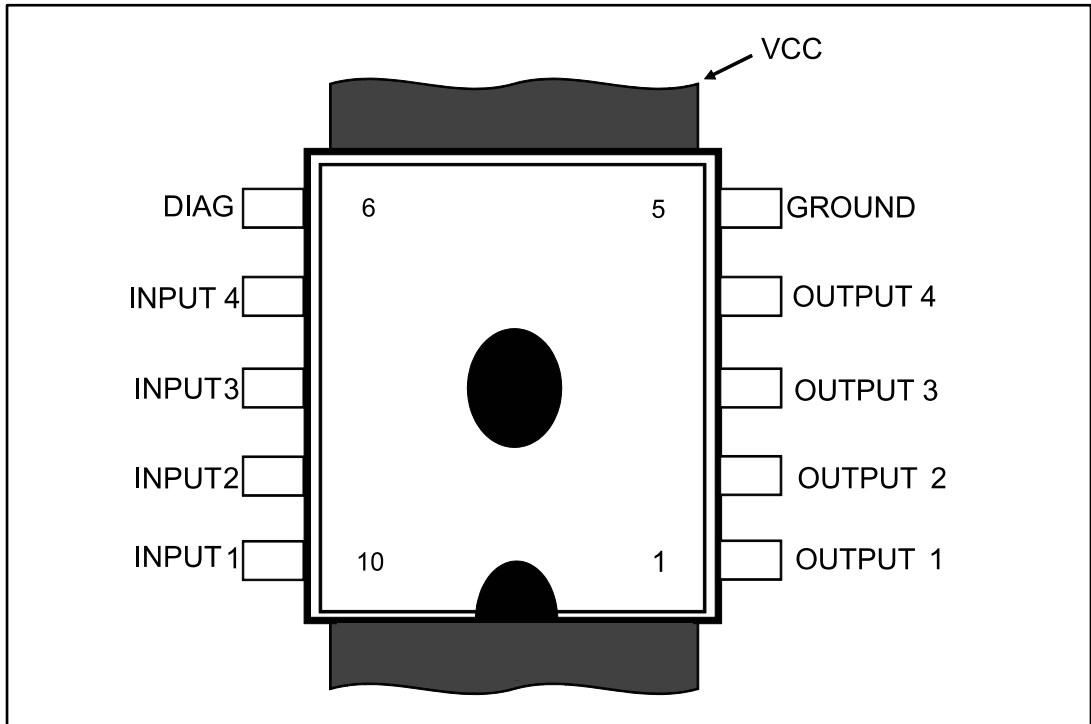
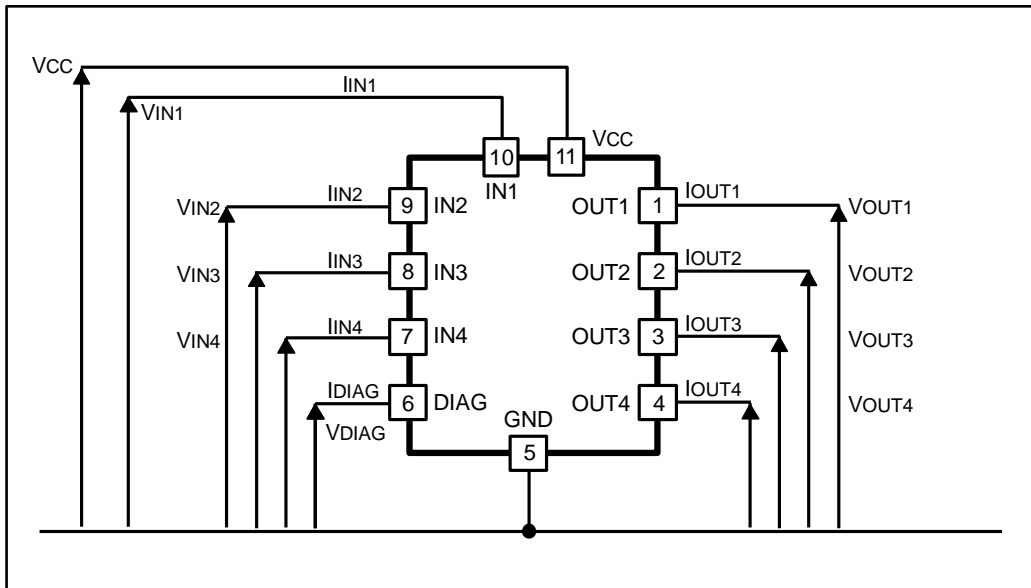

Figure 3: Current and voltage conventions



3 Maximum ratings

Table 2: Absolute maximum ratings

Symbol	Parameter	Value	Unit
V _{CC}	Power supply voltage	45	V
-V _{CC}	Reverse supply voltage	-0.3	V
I _{OUT}	Output current	Internally limited	A
I _R	Reverse output current (per channel)	-6	A
I _{IN}	Input current range	±10	mA
I _{DIAG}	DIAG pin current	±10	mA
V _{ESD}	Electrostatic discharge (R = 1.5 kΩ; C = 100 pF)	2000	V
E _{AS}	Single pulse avalanche energy per channel not simultaneously	400	mJ
P _{TOT}	Power dissipation at T _C = 25 °C	Internally limited	W
T _J	Junction operating temperature	Internally limited	°C
T _{STG}	Storage temperature	-55 to 150	°C

Table 3: Thermal data

Symbol	Parameter	Value	Unit
R _{th(JC)}	Thermal resistance junction-case ⁽¹⁾	Max. 2	°C/W
R _{th(JA)}	Thermal resistance junction-ambient ⁽²⁾	Max. 50	°C/W

Notes:

⁽¹⁾Per channel.

⁽²⁾When mounted on a four-layer FR-4, with the minimum recommended pad size.

4 Electrical characteristics

10 V < V_{CC} < 36 V; -40 °C < T_J < 125 °C; unless otherwise specified

Table 4: Power section

Symbol	Parameter	Test conditions	Min.	Typ.	Max.	Unit
V _{CC}	Supply voltage		10		36	V
R _{DS(on)}	On-state resistance	I _{OUT} = 0.5 A at T _J = 25 °C			0.2	Ω
		I _{OUT} = 0.5 A at T _J = 85 °C			0.32	
		I _{OUT} = 0.5 A at T _J = 125 °C			0.44	
I _s	Supply current	All channels OFF			1	mA
		On-state V _{IN} = 5 V, I _{OUT} = 0 V, T _J = -40 °C			15	mA
V _{demag}	Output voltage at turn-off	I _{OUT} = 0.5 A; L _{LOAD} >= 1 mH	V _{CC} -65	V _{CC} -55	V _{CC} -45	V

Table 5: Switching (V_{CC} = 24 V)

Symbol	Parameter	Test conditions	Min.	Typ.	Max.	Unit
t _{d(ON)}	Turn-on delay time	I _{OUT} = 0.5 A, resistive load, input rise time < 0.1 μs, T _J = 25 °C		30	40	μs
		I _{OUT} = 0.5 A, resistive load, input rise time < 0.1 μs, T _J = 125 °C			60	
t _r	Rise time of output current	I _{OUT} = 0.5 A, resistive load, input rise time < 0.1 μs, T _J = 25 °C		50	100	μs
		I _{OUT} = 0.5 A, resistive load, input rise time < 0.1 μs, T _J = 125 °C			115	
t _{d(OFF)}	Turn-off delay time of output current	I _{OUT} = 0.5 A, resistive load, input rise time < 0.1 μs, T _J = 25 °C		20	30	μs
		I _{OUT} = 0.5 A, resistive load, input rise time < 0.1 μs, T _J = 125 °C			40	
t _f	Fall time of output current	I _{OUT} = 0.5 A, resistive load, input rise time < 0.1 μs, T _J = 25 °C		8	15	μs
		I _{OUT} = 0.5 A, resistive load, input rise time < 0.1 μs, T _J = 125 °C			20	
(di/dt) _{on}	Turn-on current slope	I _{OUT} = 0.5 A			0.5	A/μs
		I _{OUT} = I _{LIM} , T _J = 25 °C			2	

Symbol	Parameter	Test conditions	Min.	Typ.	Max.	Unit
$(di/dt)_{off}$	Turn-off current slope	$I_{OUT} = 0.5 \text{ A}$			2	A/ μs
		$I_{OUT} = I_{LIM}, T_J = 25 \text{ }^\circ\text{C}$			4	

Table 6: Logic inputs

Symbol	Parameter	Test conditions	Min.	Typ.	Max.	Unit
V_{IL}	Input low level voltage				2	V
V_{IH}	Input high level voltage		3.5			V
$V_{I(HYST)}$	Input hysteresis voltage			0.5		V
I_{IN}	Input current	$V_{IN} = 0 \text{ to } 30 \text{ V}$			600	μA
I_{LGND}	Output current in ground disconnection	$V_{CC} = V_{INn} = \text{GND} = \text{DIAG} = 24 \text{ V}; T_J = 25 \text{ }^\circ\text{C}$			25	mA
V_{ICL}	Input clamp voltage ⁽¹⁾	$I_{IN} = 1 \text{ mA}$	32	36		V
		$I_{IN} = -1 \text{ mA}$		-0.7		V

Notes:

⁽¹⁾The input voltage is internally clamped at 32 V minimum, the input pins can be connected to a higher voltage by an external resistor, which cannot exceed 10 mA

Table 7: Protection and diagnostic

Symbol	Parameter	Test conditions	Min.	Typ.	Max.	Unit
$V_{DIAG}^{(1)}$	Status voltage output low	$I_{DIAG} = 5 \text{ mA}$ (fault condition)			1	V
$V_{SCL}^{(1)}$	Status clamp voltage	$I_{DIAG} = 1 \text{ mA}$	32	36		
		$I_{DIAG} = -1 \text{ mA}$		-0.7		
V_{USD}	Undervoltage shutdown		5		8	V
V_{OL}	Low state output voltage	$V_{IN} = V_{IL}$; $R_{LOAD} < 10 \text{ m}\Omega$			1.5	V
I_{LIM}	DC short-circuit current	$V_{CC} = 24 \text{ V}$; $R_{LOAD} < 10 \text{ m}\Omega$	0.7		2.5	A
I_{OVPK}	Peak short-circuit current	$V_{CC} = 24 \text{ V}$; $V_{IN} = 30 \text{ V}$; $R_{LOAD} < 10 \text{ m}\Omega$			4	A
I_{DIAGH}	Leakage on DIAG pin in high state	$V_{DIAG} = 24 \text{ V}$			100	μA
I_{LOAD}	Output leakage current	$V_{CC} = 10 \text{ to } 36 \text{ V}$; $V_{IN} = V_{IL}$			50	μA
t_{SC}	Delay time of current limiter				100	μs
T_{TSD}	Thermal shutdown temperature		150	170		$^{\circ}\text{C}$
T_R	Thermal reset temperature		135	155		$^{\circ}\text{C}$

Notes:

⁽¹⁾Status determination > 100 μs after the switching edge.



If the INPUT pin is left floating, the corresponding channel automatically switches off. If GND pin is disconnected, the channel switches off provided that V_{CC} does not exceed 36 V.

5 Test circuits

Figure 4: Avalanche energy test circuit

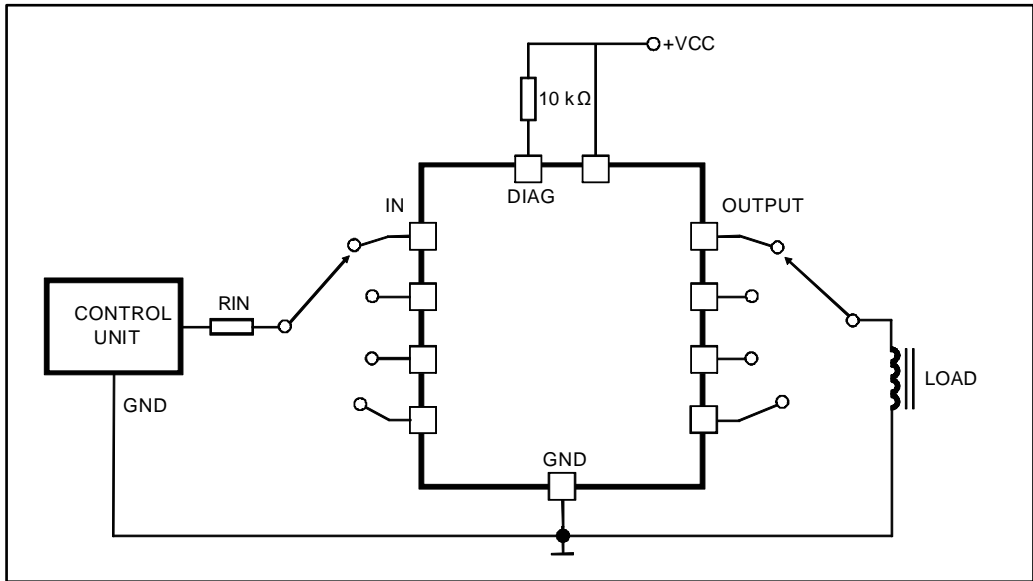
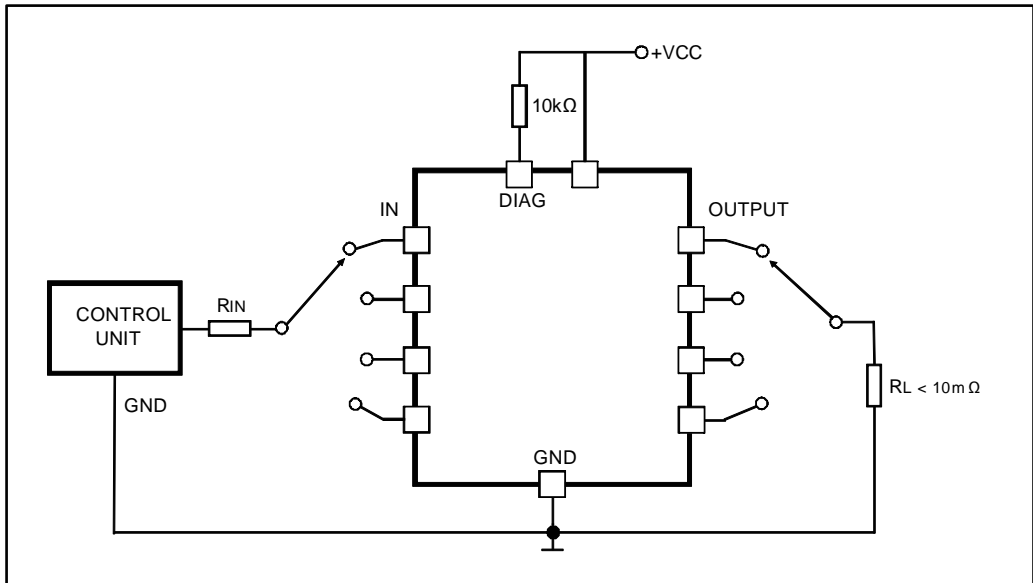

Figure 5: Peak short-circuit test diagram



6 Switching time waveforms and truth table

Table 8: Truth table

Conditions	INPUTn	OUTPUTn	Diagnostic
Normal operation	L	L	H
	H	H	H
Overtemperature	L	L	H
	H	L	L
Undervoltage	L	L	H
	H	L	H
Shorted load current limitation	L	L	H
	H	H	H

Figure 6: Switching waveforms

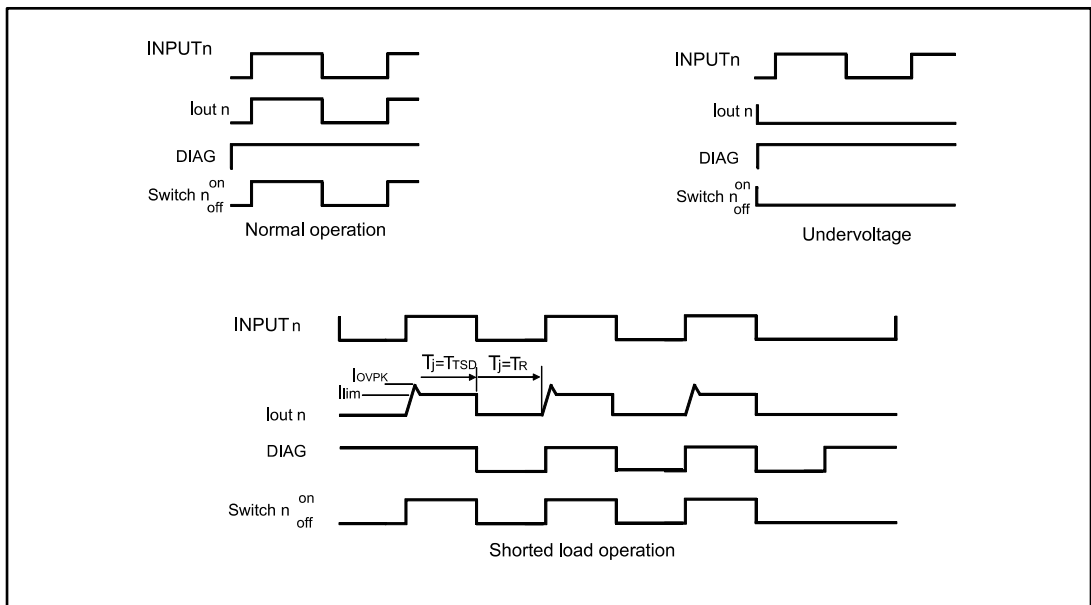

Figure 7: Switching parameter test conditions

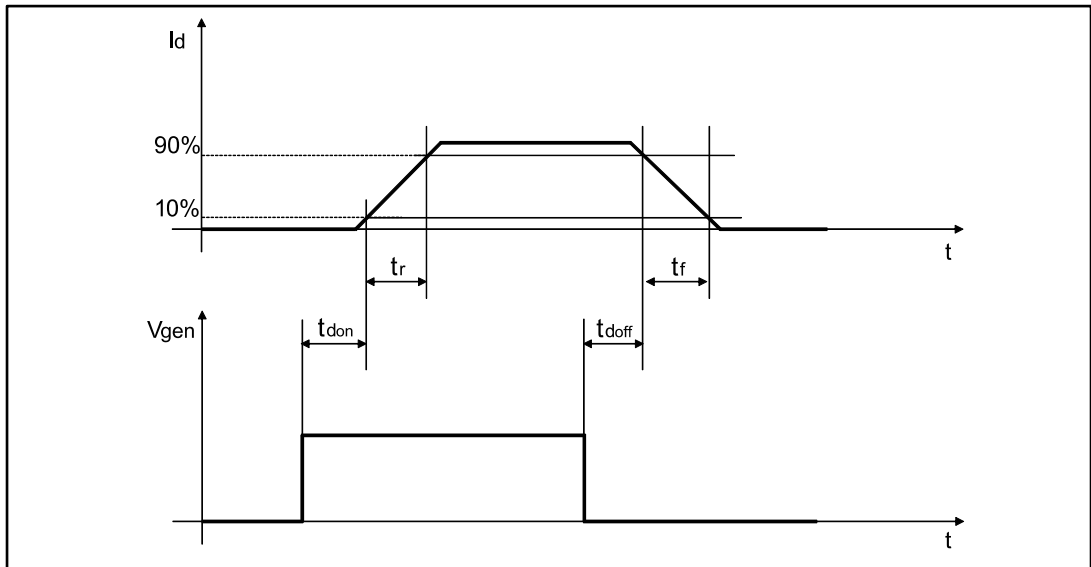

Figure 8: Driving circuit

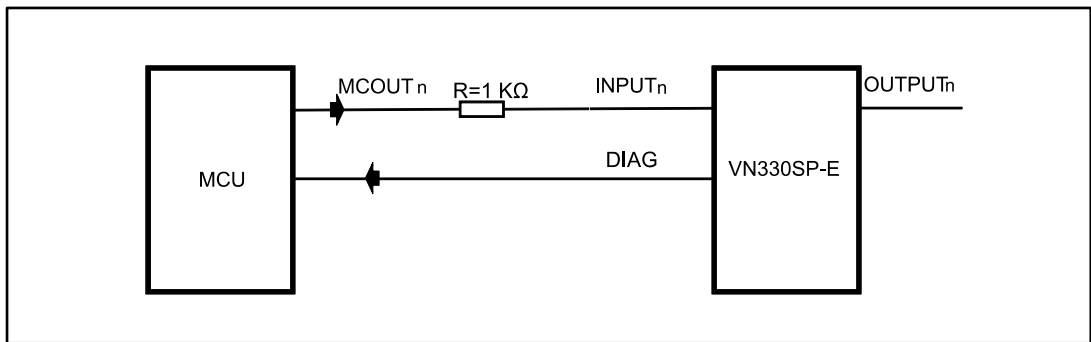

Table 9: PowerSO-10 package mechanical data

Dim.	mm		
	Min.	Typ.	Max.
A1	0	0.05	0.1
A2	3.4	3.5	3.6
A3	1.2	1.3	1.4
A4	0.15	0.2	0.25
a		0.2	
b	0.37	0.45	0.53
c	0.23	0.27	0.32
D	9.4	9.5	9.6
D1	7.4	7.5	7.6
d	0	0.05	0.1
E	13.85	14.1	14.35
E1 ⁽¹⁾	9.3	9.4	9.5
E2	7.3	7.4	7.5
E3	5.9	6.1	6.3
e		1.27	
e1		5.08	
F		0.5	
G		1.2	
L	0.8	1	1.1
R1			0.25
R2		0.8	
T	2 deg	5 deg	8 deg
T1		6 deg	
T2		10 deg	

Notes:

⁽¹⁾Resin protrusions are not included (max. value 0.15 mm per side)

7.2 PowerSO-10 packing information

Figure 10: PowerSO-10 career tape outline

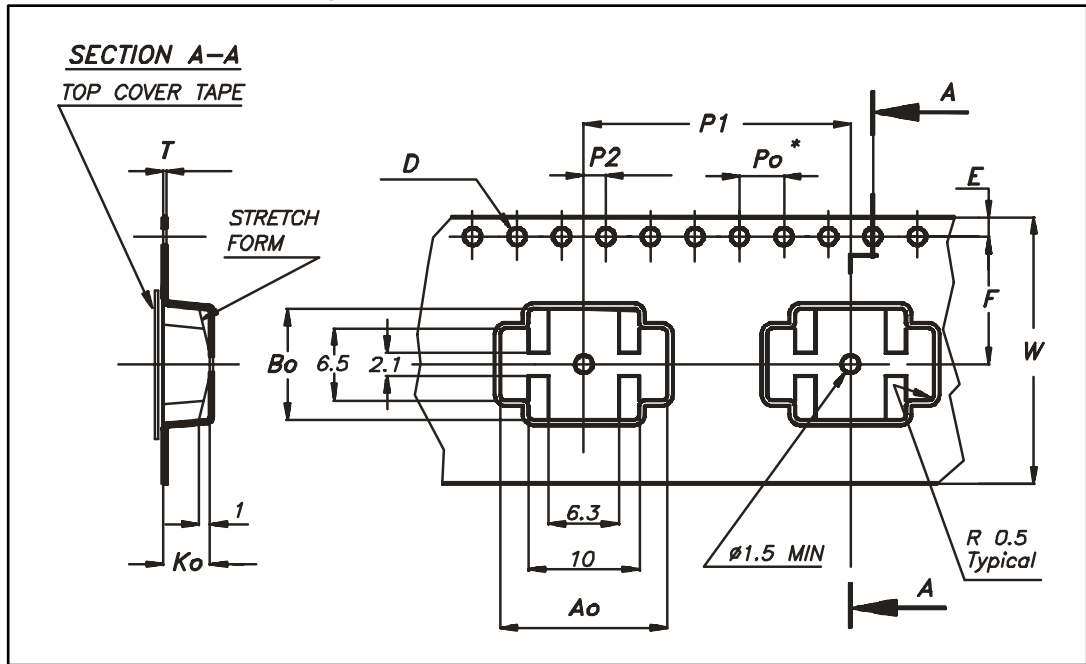

Drawing is not in scale

Table 10: PowerSO-10 carrier tape dimension mechanical data

Dim.	mm		
	Min.	Typ.	Max.
A0	14.9	15.0	15.1
B0	9.9	10.0	10.1
K0	4.15	4.25	4.35
F	11.4	11.5	11.6
E	1.65	1.75	1.85
W	23.7	24.0	24.3
P2	1.9	2.0	2.1
P0	3.9	4.0	4.1
P1	23.9	24.0	24.1
T	0.025	0.30	0.35
D(∅)	1.50	1.55	1.60



10 sprocket hole pitch cumulative tolerance ± 0.2 mm

Figure 11: PowerSO-10 reel outline

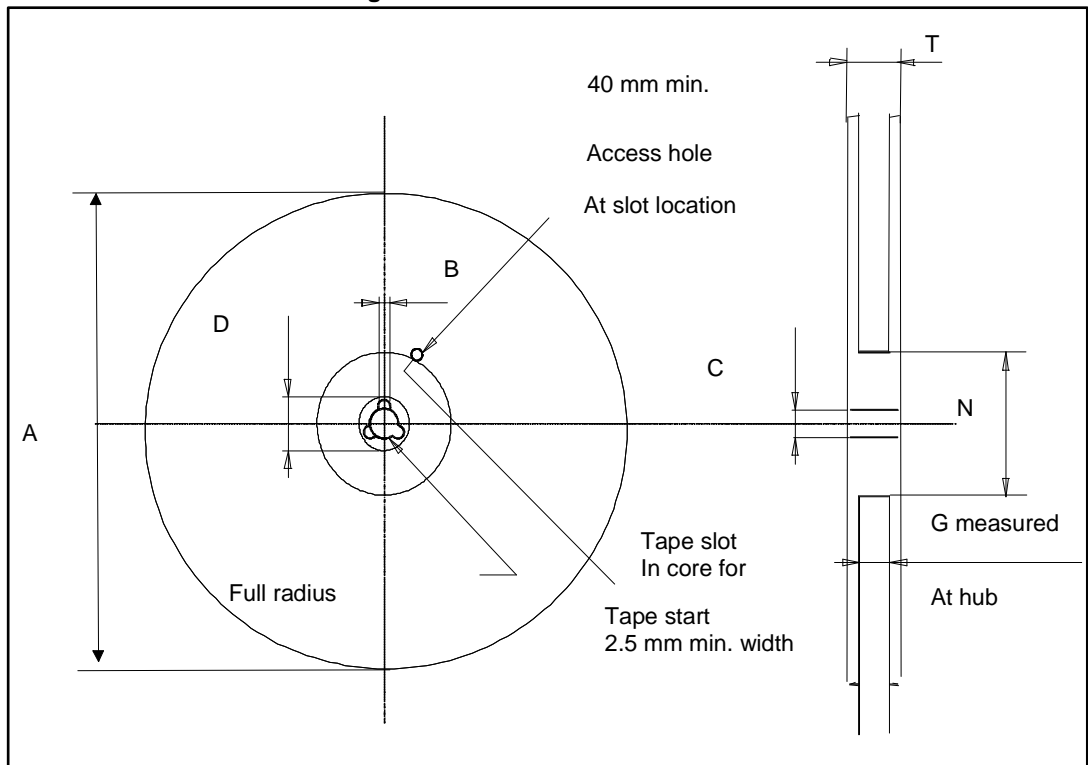

Drawing is not in scale

Table 11: PowerSO-10 reel dimension mechanical data

Dim.	mm		
	Min.	Typ.	Max.
A			330
B	1.5		
C	12.8	13	13.2
D	20.2		
N	60		
G	23.7	24.4	
T			30.4

Table 12: PowerSO-10 base and bulk quantity in tape and reel

Base quantity	Bulk quantity
600	600

Figure 12: PowerSO-10 suggested pad and tube shipment (no suffix)

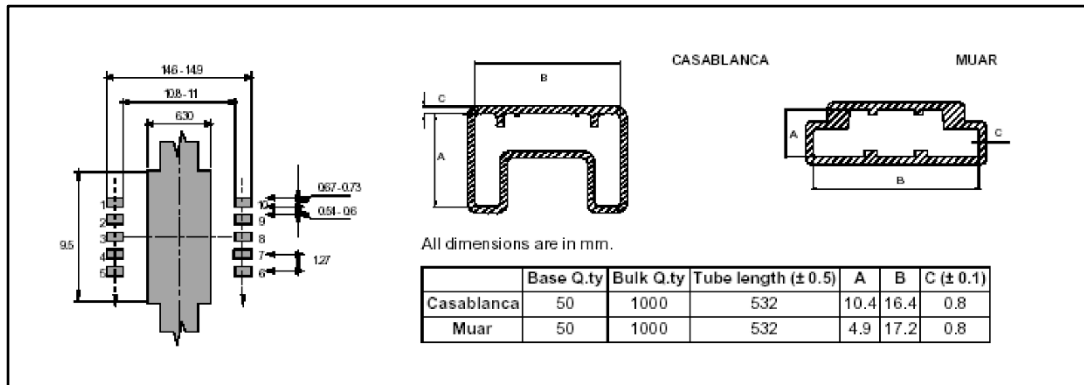

10 sprocket hole pitch cumulative tolerance ± 0.2 mm

8 Revision history

Table 13: Document revision history

Date	Revision	Changes
06-Sep-2005	1	Initial release.
31-Oct-2006	2	Typo in electrical characteristics temperature conditions updated <i>on page 5</i>
27-Mar-2007	3	Document reformatted, typo in <i>Note 1 on page 6</i>
14-Feb-2017	4	Updated <i>Table 4: "Power section"</i> . Inserted <i>Figure 12: "PowerSO-10 suggested pad and tube shipment (no suffix)"</i> .

IMPORTANT NOTICE – PLEASE READ CAREFULLY

STMicroelectronics NV and its subsidiaries ("ST") reserve the right to make changes, corrections, enhancements, modifications, and improvements to ST products and/or to this document at any time without notice. Purchasers should obtain the latest relevant information on ST products before placing orders. ST products are sold pursuant to ST's terms and conditions of sale in place at the time of order acknowledgement.

Purchasers are solely responsible for the choice, selection, and use of ST products and ST assumes no liability for application assistance or the design of Purchasers' products.

No license, express or implied, to any intellectual property right is granted by ST herein.

Resale of ST products with provisions different from the information set forth herein shall void any warranty granted by ST for such product.

ST and the ST logo are trademarks of ST. All other product or service names are the property of their respective owners.

Information in this document supersedes and replaces information previously supplied in any prior versions of this document.

© 2017 STMicroelectronics – All rights reserved

Looking for pricing, stock, or lifecycle information?

Click below to explore more details on WIN SOURCE:

-  [View VN330SPTR-E on WIN SOURCE](#)
-  [STMicroelectronics Information](#)

Optimize Your Supply Chain with WIN SOURCE Solutions

-  Global Sourcing Solution
-  Obsolete Management
-  Cost Control Management
-  Shortage Management
-  Alternative Solution
-  Excess Inventory Management