

## High Speed USB 2.0 Switch with ESD Protection and Low Standby Current

### Features

- High Speed USB Mux for multiplexing the USB lanes between different functions
  - Switch the USB connector between two different functions
  - Up to 1GHz Bandwidth
- USB Port ESD Protection (DP/DM)
  - 8kV HBM
- flexPWR™ Technology
  - 30nA Active/Standby Current
  - Extremely low power design ideal for battery powered applications
- Control inputs accommodate 1.8V to 5V inputs
- DP/DM tolerate up to 5.5V
- -40°C to +85°C Operating Temperature
- 10-pin, QFN, RoHS compliant package; (1.3mm x 1.8mm x 0.55mm height, 0.4mm pitch)
- 10-pin, QFN, RoHS compliant package; (1.6mm x 2.1mm x 0.55mm height, 0.5mm pitch)
- Automotive option

### Block Diagram

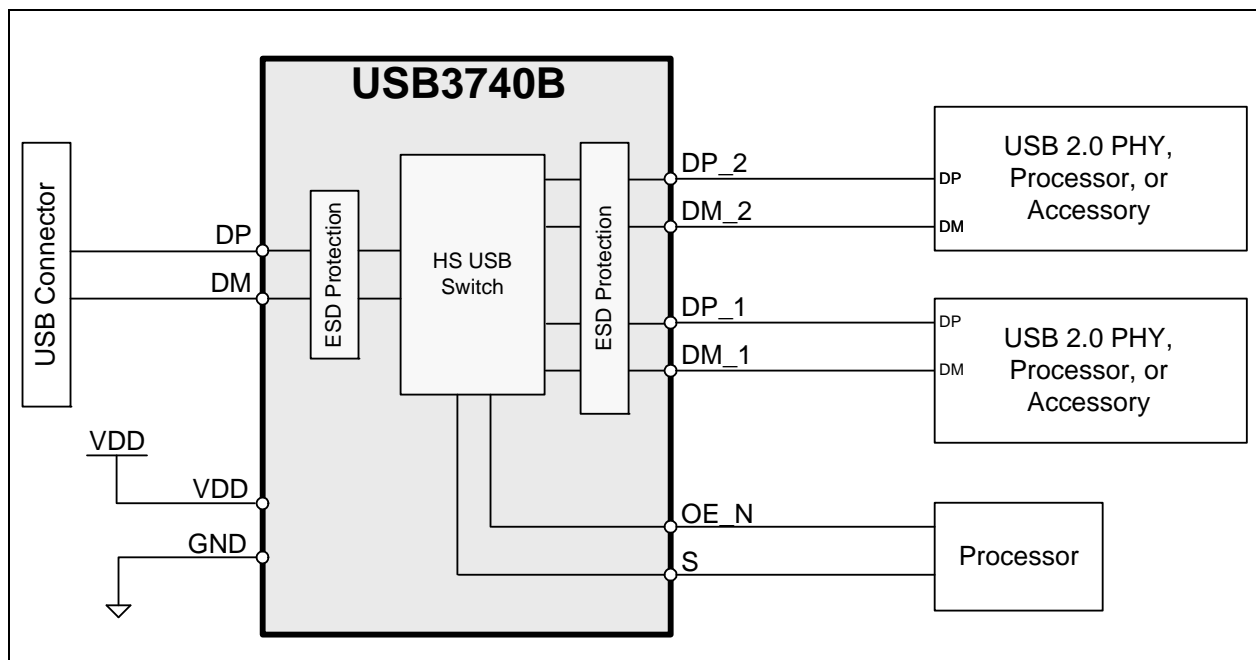

## TO OUR VALUED CUSTOMERS

It is our intention to provide our valued customers with the best documentation possible to ensure successful use of your Microchip products. To this end, we will continue to improve our publications to better suit your needs. Our publications will be refined and enhanced as new volumes and updates are introduced.

If you have any questions or comments regarding this publication, please contact the Marketing Communications Department via E-mail at [docerrors@microchip.com](mailto:docerrors@microchip.com). We welcome your feedback.

### Most Current Data Sheet

To obtain the most up-to-date version of this data sheet, please register at our Worldwide Web site at:

<http://www.microchip.com>

You can determine the version of a data sheet by examining its literature number found on the bottom outside corner of any page. The last character of the literature number is the version number, (e.g., DS30000000A is version A of document DS30000000).

### Errata

An errata sheet, describing minor operational differences from the data sheet and recommended workarounds, may exist for current devices. As device/documentation issues become known to us, we will publish an errata sheet. The errata will specify the revision of silicon and revision of document to which it applies.

To determine if an errata sheet exists for a particular device, please check with one of the following:

- Microchip's Worldwide Web site; <http://www.microchip.com>
- Your local Microchip sales office (see last page)

When contacting a sales office, please specify which device, revision of silicon and data sheet (include -literature number) you are using.

### Customer Notification System

Register on our web site at [www.microchip.com](http://www.microchip.com) to receive the most current information on all of our products.

## Table of Contents

- 1.0 General Description ..... 4
- 2.0 Pin Layout ..... 5
- 3.0 Electrical Specifications ..... 6
- 4.0 General Operation ..... 7
- 5.0 Application Notes ..... 8
- 6.0 Package Outlines ..... 9
- The Microchip Web Site ..... 16
- Customer Change Notification Service ..... 16
- Customer Support ..... 16
- Product Identification System ..... 17

# USB3740B

## 1.0 GENERAL DESCRIPTION

The USB3740B is a USB 2.0 compliant High Speed switch that provides robust ESD protection to the interface in an extremely small package. Outstanding ESD robustness eliminates the need for external ESD protection devices to save eBOM cost and PCB area.

The high bandwidth capabilities of the USB3740B enable extremely low high frequency loss and an exceptionally clean USB 2.0 High Speed eye diagram.

**FIGURE 1-1: USB3740B USB 2.0 HIGH SPEED EYE DIAGRAM**

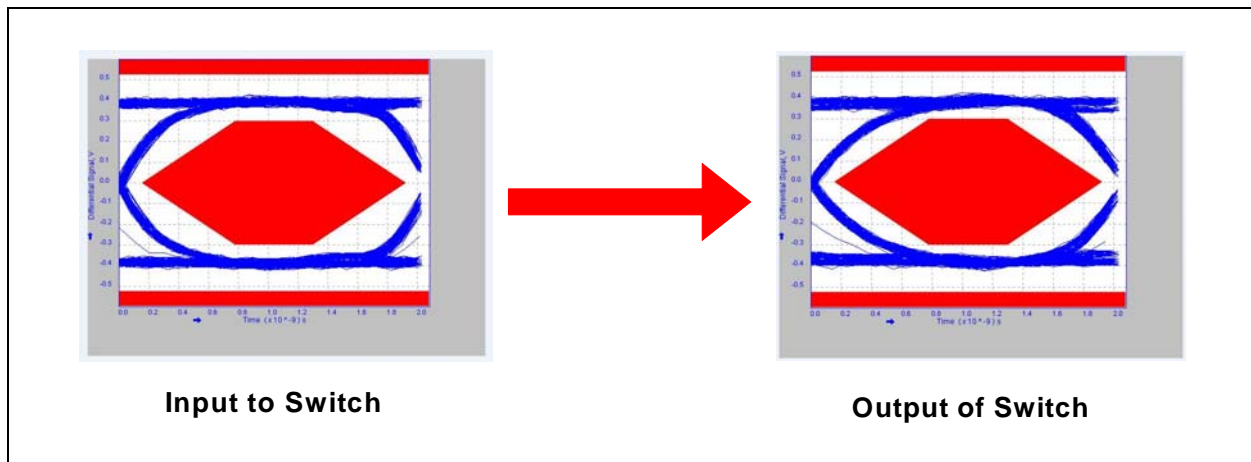

## 1.1 Reference Document

Universal Serial Bus Specification, Revision 2.0

## 2.0 PIN LAYOUT

### 2.1 Pin Diagram

The USB3740B is available in both a 0.4mm pitch QFN (1.3mm x 1.8mm x 0.55mm height) and 0.5mm pitch QFN (1.6mm x 2.1mm x 0.55mm height) package. The 0.5mm pitch package can be ordered in standard or automotive configurations. For additional ordering information, refer to the [Product Identification System](#) section.

**FIGURE 2-1: USB3740B PACKAGE DIAGRAM**

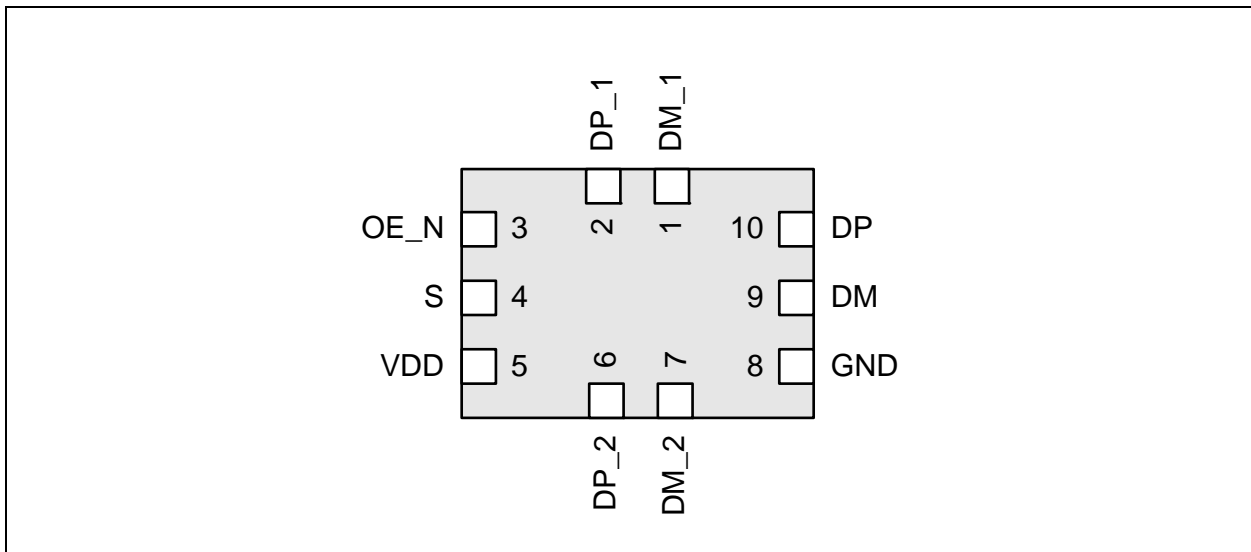

### 2.2 Ball/Pin Definitions

The following table details the ball/pin definitions for the package diagram above.

Pin	Name	Type/ Direction	Description
10	DP	Analog	USB Mux Output
9	DM	Analog	
2	DP_1	Analog	USB Mux Input 1
1	DM_1	Analog	
6	DP_2	Analog	USB Mux Input 2
7	DM_2	Analog	
8	GND	Analog	Ground
5	VDD	Analog	Power
4	S	Digital Input	Switch control. Refer to <a href="#">Table 4-1</a> .
3	OE_N	Digital Input	Active low switch Output Enable. Refer to <a href="#">Table 4-1</a> .

# USB3740B

## 3.0 ELECTRICAL SPECIFICATIONS

### 3.1 Absolute Maximum Ratings

TABLE 3-1: ABSOLUTE MAXIMUM RATINGS

Description	Rating	Unit
VDD Voltage to GND	-0.3 to 6.0	V
Any other pin to GND	-0.3 to VDD+0.5	V
Operating Temperature Range	-40 to +85	C
Storage Temperature Range	-55 to +150	C
ESD Rating	HBM	8,000
		V

Stresses beyond the Absolute Maximum Ratings may damage the USB3740B.

### 3.2 Electrical Specifications

TABLE 3-2: ELECTRICAL SPECIFICATIONS

Characteristic	Symbol	MIN	TYP	MAX	Units	Conditions
V <sub>DD</sub> = 5.0V, T <sub>A</sub> = -40C to 85C, all typical values at T <sub>A</sub> = 25C unless otherwise noted.						
VDD Recommended Operating Conditions						
Input Voltage	V <sub>DD</sub>	3.0		5.5	V	
Active/Standby	I <sub>DD</sub>		30	175	nA	
USB Mux Characteristics						
USB Mux On Resistance	R <sub>ON_USB</sub>	1	2	5	ohm	0V < Vin < 3.3V
		1	2	2.5		0V < Vin < 0.4V
USB Mux Off Leakage	I <sub>OFF_USB</sub>		100	200	nA	0V < Vin < 3.3V
On Capacitance	C <sub>ON_USB</sub>		5	7	pF	V <sub>DD</sub> = 3V
Off Capacitance	C <sub>OFF_USB</sub>		3	4	pF	V <sub>DD</sub> = 3V
Off Isolation		-30	-32	-40	dB	R <sub>L</sub> = 50 ohm, F = 250MHz
Crosstalk		-30	-45	-60	dB	R <sub>L</sub> = 50 ohm, F = 250MHz
Bandwidth (-3dB)	BW	950	1000	1100	MHz	R <sub>L</sub> = 50 ohm, C <sub>L</sub> = 0pF
		850	950	980		R <sub>L</sub> = 50 ohm, C <sub>L</sub> = 5pF
		530	560	600		R <sub>L</sub> = 50 ohm, C <sub>L</sub> = 10pF
Control Signal Characteristics						
Input Logic High Threshold	V <sub>IN_H</sub>	1.4			V	
Input Logic Low Threshold	V <sub>IN_L</sub>			0.4	V	

## 4.0 GENERAL OPERATION

The USB3740B is a high bandwidth switch suitable for many applications, including High Speed USB. The mux allows high speed signals to pass through and still meet HS USB signaling requirements.

The USB3740B will protect the system from ESD stress events on all **DP** and **DM** pins. The USB3740B provides ESD protection to the IEC-61000 ESD specification.

The USB mux is designed to pass High Speed USB signals to the USB connector, and allows for two USB inputs to be multiplexed into one USB output.

The USB Mux is designed to pass USB signals from 0 to **VDD**. It is not designed to pass signals that go above **VDD** or below ground.

The USB3740B switches are controlled by the digital signals OE\_N and S, as shown in [Table 4-1](#).

**TABLE 4-1: USB3740B SWITCH STATES DEFINITION**

OE_N	S	Switch State
1	X	STANDBY: <ul style="list-style-type: none"><li>• Both switch paths disconnected.</li><li>• Lowest power state</li></ul>
0	0	DP = DP1, DM = DM1:
0	1	DP = DP2, DM = DM2:

# USB3740B

---

## 5.0 APPLICATION NOTES

### 5.1 ESD Performance

The USB3740B is protected from ESD strikes. By eliminating the requirement for external ESD protection devices, board space is conserved, and the board manufacturer is enabled to reduce cost. The advanced ESD structures integrated into the USB3740B protect the device whether or not it is powered up.

#### 5.1.1 HUMAN BODY MODEL (HBM) PERFORMANCE

HBM testing verifies the ability to withstand the ESD strikes like those that occur during handling and manufacturing, and is done without power applied to the IC. To pass the test, the device must have no change in operation or performance due to the event. The USB3740B HBM performance is detailed in [Table 3-1](#).

## 6.0 PACKAGE OUTLINES

### 6.1 1.3mm x 1.8mm QFN

FIGURE 6-1: 10-PIN, 1.3MM X 1.8MM QFN PACKAGE OUTLINE

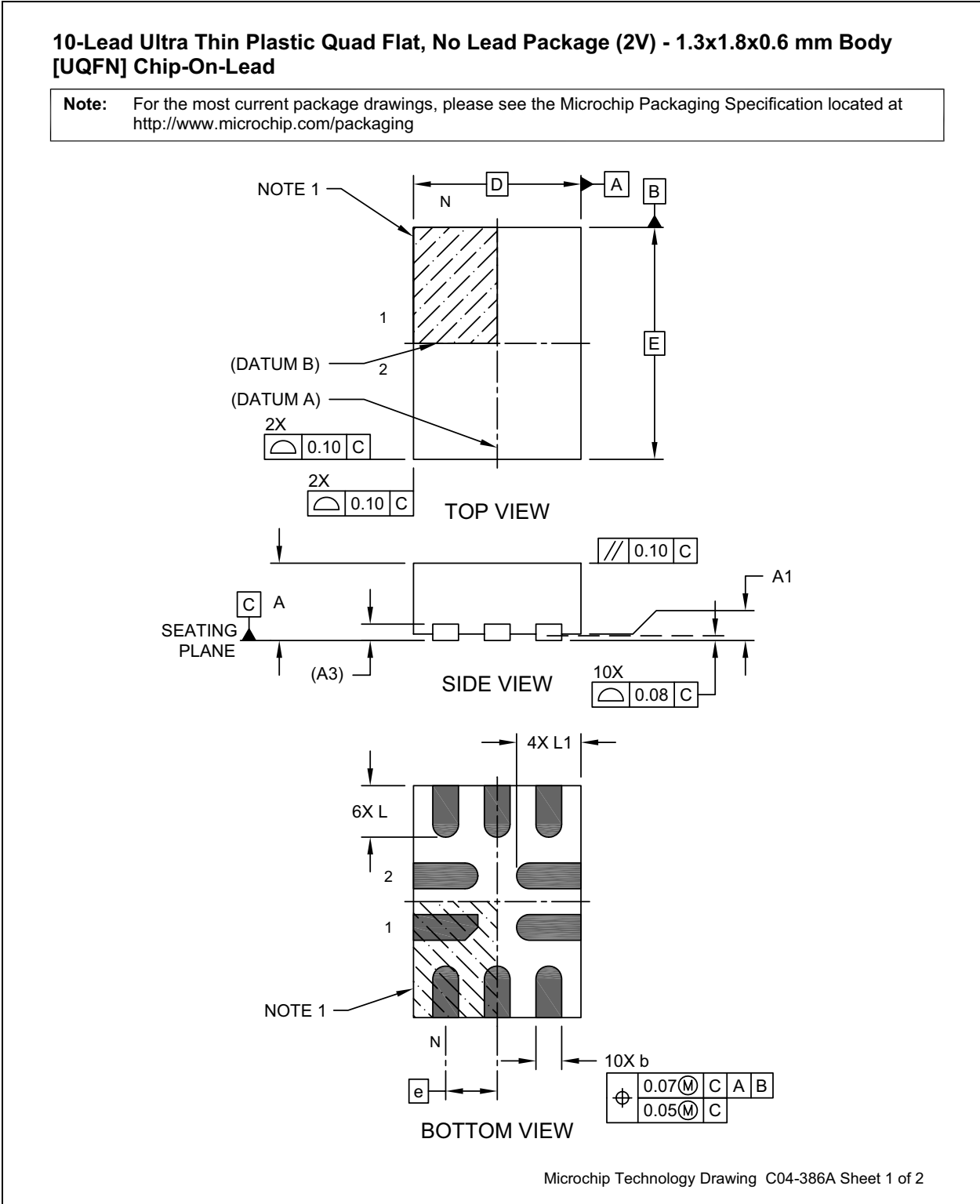

# USB3740B

FIGURE 6-2: 10-PIN, 1.3MM X 1.8MM QFN PACKAGE DIMENSIONS

## 10-Lead Ultra Thin Plastic Quad Flat, No Lead Package (2V) - 1.3x1.8x0.6 mm Body [UQFN] Chip-On-Lead

**Note:** For the most current package drawings, please see the Microchip Packaging Specification located at <http://www.microchip.com/packaging>

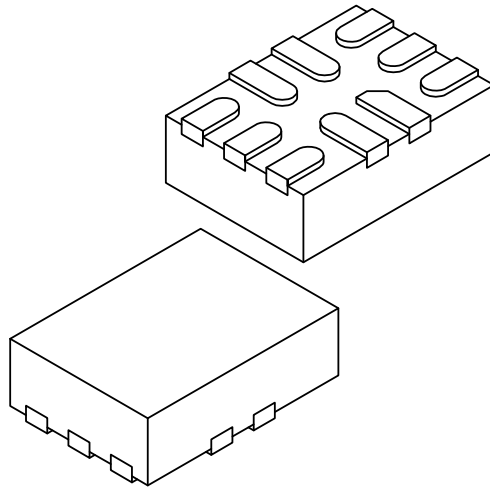

Dimension Limits	Units	MILLIMETERS		
		MIN	NOM	MAX
Number of Terminals	N	10		
Pitch	e	0.40 BSC		
Overall Height	A	0.50	0.55	0.60
Standoff	A1	0.00	0.02	0.05
Terminal Thickness	A3	0.127 REF		
Overall Length	D	1.30 BSC		
Overall Width	E	1.80 BSC		
Terminal Width	b	0.15	0.20	0.25
Terminal Length	L	0.35	0.40	0.45
Terminal Length	L1	0.45	0.50	0.55

**Notes:**

1. Pin 1 visual index feature may vary, but must be located within the hatched area.
2. Package is saw singulated
3. Dimensioning and tolerancing per ASME Y14.5M

BSC: Basic Dimension. Theoretically exact value shown without tolerances.

REF: Reference Dimension, usually without tolerance, for information purposes only.

Microchip Technology Drawing C04-386A Sheet 2 of 2

**FIGURE 6-3: 10-PIN, 1.3MM X 1.8MM QFN PACKAGE LAND PATTERN**

**10-Lead Ultra Thin Plastic Quad Flat, No Lead Package (2V) - 1.3x1.8x0.6 mm Body [UQFN] Chip-On-Lead**

**Note:** For the most current package drawings, please see the Microchip Packaging Specification located at <http://www.microchip.com/packaging>

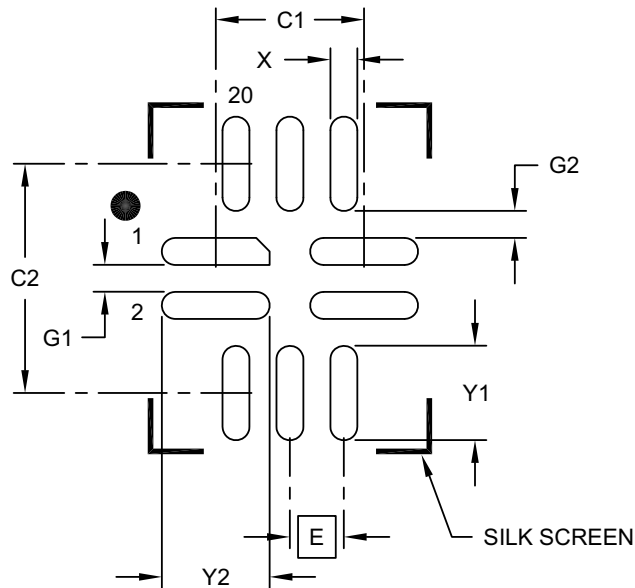

**RECOMMENDED LAND PATTERN**

Dimension Limits	Units	MILLIMETERS		
		MIN	NOM	MAX
Contact Pitch	E	0.40 BSC		
Contact Pad Spacing	C1		1.10	
Contact Pad Spacing	C2		1.70	
Contact Pad Width (X10)	X			0.20
Contact Pad Length (X6)	Y1			0.70
Contact Pad Length (X4)	Y2			0.80
Contact Pad to Pad (X6)	G1	0.20		
Contact Pad to Pad (X4)	G2	0.20		

**Notes:**

- Dimensioning and tolerancing per ASME Y14.5M  
BSC: Basic Dimension. Theoretically exact value shown without tolerances.

Microchip Technology Drawing C04-2386A

# USB3740B

## 6.2 1.6mm x 2.1mm QFN

FIGURE 6-4: 10-PIN, 1.6MM X 2.1MM QFN PACKAGE OUTLINE

### 10-Lead Ultra Thin Plastic Quad Flat, No Lead Package (3V) - 1.6x2.1 mm Body [UQFN Chip-On-Lead

**Note:** For the most current package drawings, please see the Microchip Packaging Specification located at <http://www.microchip.com/packaging>

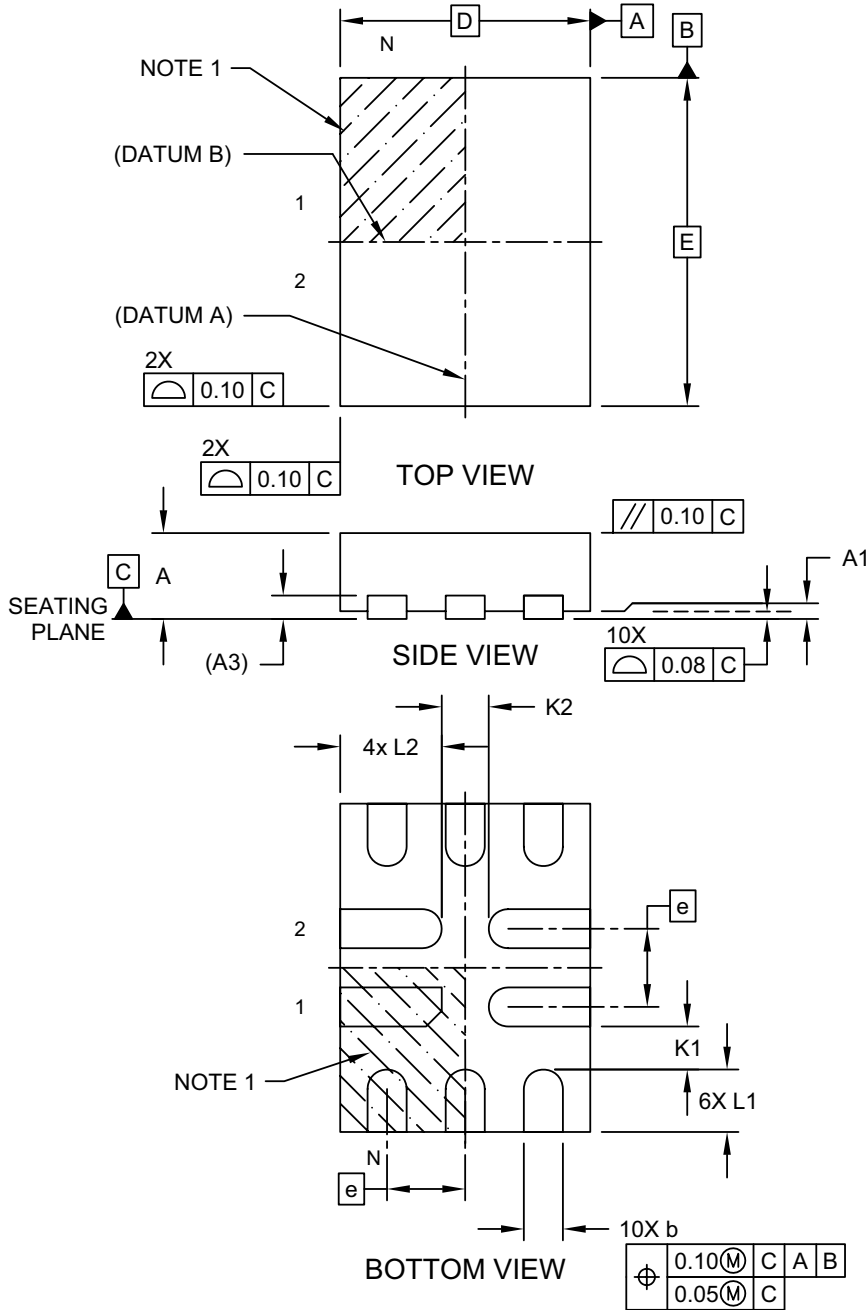

Microchip Technology Drawing C04-381A Sheet 1 of 2

**FIGURE 6-5: 10-PIN, 1.6MM X 2.1MM QFN PACKAGE DIMENSIONS**

**10-Lead Ultra Thin Plastic Quad Flat, No Lead Package (3V) - 1.6x2.1 mm Body [UQFN] Chip-On-Lead**

**Note:** For the most current package drawings, please see the Microchip Packaging Specification located at <http://www.microchip.com/packaging>

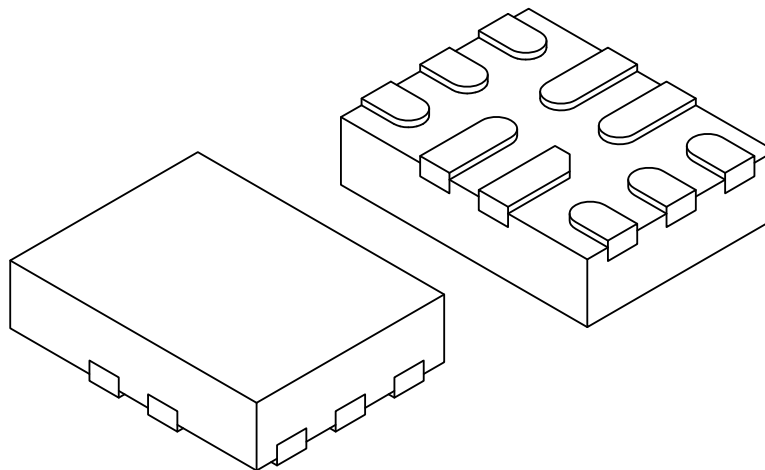

Units		MILLIMETERS		
Dimension Limits		MIN	NOM	MAX
Number of Terminals	N	10		
Pitch	e	0.50 BSC		
Overall Height	A	0.50	0.55	0.60
Standoff	A1	0.00	0.02	0.05
Terminal Thickness	(A3)	0.127 REF		
Overall Width	E	2.10 BSC		
Overall Length	D	1.60 BSC		
Terminal Width	b	0.20	0.25	0.30
Terminal Length	L1	0.35	0.40	0.45
Terminal Length	L2	0.60	0.65	0.70
Terminal Clearance	K1	0.20	-	-
Terminal Clearance	K2	0.20	-	-

**Notes:**

1. Pin 1 visual index feature may vary, but must be located within the hatched area.
2. Package is saw singulated
3. Dimensioning and tolerancing per ASME Y14.5M
  - BSC: Basic Dimension. Theoretically exact value shown without tolerances.
  - REF: Reference Dimension, usually without tolerance, for information purposes only.

Microchip Technology Drawing C04-379A Sheet 2 of 2

# USB3740B

FIGURE 6-6: 10-PIN, 1.6MM X 2.1MM QFN PACKAGE LAND PATTERN

## 10-Lead Ultra Thin Plastic Quad Flat, No Lead Package (3V) - 1.6.x2.1 mm Body [UQFN Chip-On-Lead

**Note:** For the most current package drawings, please see the Microchip Packaging Specification located at <http://www.microchip.com/packaging>

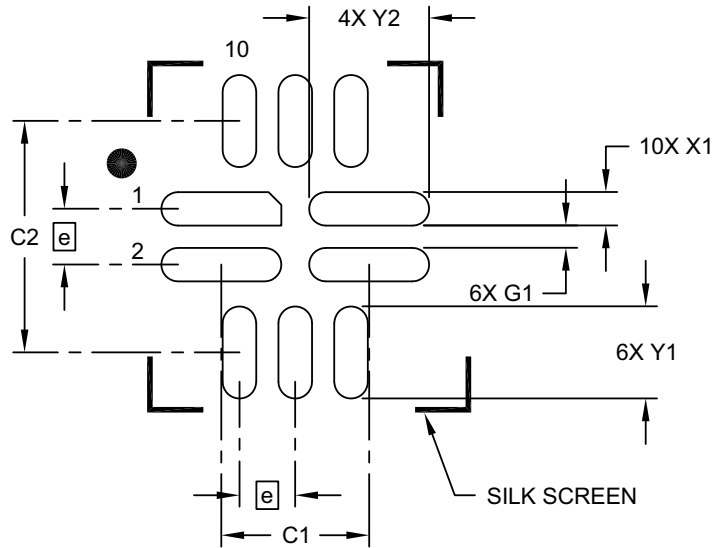

### RECOMMENDED LAND PATTERN

Dimension Limits	Units	MILLIMETERS		
		MIN	NOM	MAX
Contact Pitch	E	0.50 BSC		
Contact Pad Spacing	C1		1.325	
Contact Pad Spacing	C2		2.075	
Contact Pad Width (X10)	X1			0.30
Contact Pad Length (X6)	Y1			0.825
Contact Pad Length (X4)	Y2			1.075
Contact Pad to Center Pad (X6)	G1	0.20		

**Notes:**

1. Dimensioning and tolerancing per ASME Y14.5M  
BSC: Basic Dimension. Theoretically exact value shown without tolerances.

Microchip Technology Drawing C04-2381A

## APPENDIX A: DATA SHEET REVISION HISTORY

**TABLE A-1: REVISION HISTORY**

Revision	Section/Figure/Entry	Correction
DS00001725D (03-11-15)	<a href="#">Section 6.0, "Package Outlines," on page 9</a>	Updated 1.6x2.1 UQFN and 1.3x1.8 UQFN package drawings.
DS00001725C (12-11-14)	Cover	Added bullet: "Automotive option (1.6 x 2.1mm, 0.5mm pitch package only)"  Added sub-bullet: "8kV HBM"
	<a href="#">FIGURE 6-1: 10-pin, 1.3mm x 1.8mm QFN Package Outline on page 9</a> and <a href="#">FIGURE 6-4: 10-pin, 1.6mm x 2.1mm QFN Package Outline on page 12</a>	Updated package drawings to latest revision C
	Product Identification System	Added automotive ordering code information. Added tape and reel quantity information.
	<a href="#">Section 2.1, "Pin Diagram," on page 5</a>	Clarified which package is available for the automotive option.
	All: Cover, Order Codes	Made operating temperature references generic "-40°C to +85°C"
DS00001725B (08-21-14)	Document is converted to Microchip template; Product Identification System page replaces Ordering Information.	
DS00001725A replaces the previous SMSC version, Rev. 1.2		Title changed from "High Speed Switch for Mobile and Portable Applications" to "High Speed USB 2.0 Switch with ESD Protection and Low Standby Current"
Rev. 1.2 (07-30-12)	<a href="#">Table 3-1, "Absolute Maximum Ratings," on page 6</a>	Corrected "Any other pin to GND" row's rating to "-0.3 to VDD+0.5V"
Rev. 1.1 (12-15-11)	<a href="#">Section 2.2, "Ball/Pin Definitions"</a>	In <a href="#">Section 2.2</a> , changed the description of Pin #8 as follows: "Ground"
Rev. 1.0 (08-03-11)	Data Sheet Release	

# USB3740B

---

## THE MICROCHIP WEB SITE

Microchip provides online support via our WWW site at [www.microchip.com](http://www.microchip.com). This web site is used as a means to make files and information easily available to customers. Accessible by using your favorite Internet browser, the web site contains the following information:

- **Product Support** – Data sheets and errata, application notes and sample programs, design resources, user's guides and hardware support documents, latest software releases and archived software
- **General Technical Support** – Frequently Asked Questions (FAQ), technical support requests, online discussion groups, Microchip consultant program member listing
- **Business of Microchip** – Product selector and ordering guides, latest Microchip press releases, listing of seminars and events, listings of Microchip sales offices, distributors and factory representatives

## CUSTOMER CHANGE NOTIFICATION SERVICE

Microchip's customer notification service helps keep customers current on Microchip products. Subscribers will receive e-mail notification whenever there are changes, updates, revisions or errata related to a specified product family or development tool of interest.

To register, access the Microchip web site at [www.microchip.com](http://www.microchip.com). Under "Support", click on "Customer Change Notification" and follow the registration instructions.

## CUSTOMER SUPPORT

Users of Microchip products can receive assistance through several channels:

- Distributor or Representative
- Local Sales Office
- Field Application Engineer (FAE)
- Technical Support

Customers should contact their distributor, representative or field application engineer (FAE) for support. Local sales offices are also available to help customers. A listing of sales offices and locations is included in the back of this document.

**Technical support is available through the web site at: <http://www.microchip.com/support>**

## PRODUCT IDENTIFICATION SYSTEM

To order or obtain information, e.g., on pricing or delivery, refer to the factory or the listed sales office.

### Standard Ordering Codes

<u>PART NO.</u>	-	<u>XXX</u>	-	<u>IX1</u> <sup>(1)</sup>	<b>Examples:</b>
Device		Package		Tape and Reel Option	
Device:		USB3740B			a) USB3740B-AI2-TR 10-pin QFN RoHS Compliant package (1.3 x 1.8 x 0.55mm, 0.4mm pitch) Tape & Reel
Package:		AI2 = 10-pin QFN (1.3 x 1.8 x 0.55mm, 0.4mm pitch) AI9 = 10-pin QFN (1.6 x 2.1 x 0.55mm, 0.5mm pitch)			b) USB3740B-AI9-TR 10-pin QFN RoHS Compliant package (1.6 x 2.1 x 0.55mm, 0.5mm pitch) Tape & Reel
Tape and Reel Option:		Blank = Tray packaging TR = Tape and Reel			<b>Note 1:</b> Tape and Reel identifier only appears in the catalog part number description. This identifier is used for ordering purposes and is not printed on the device package. Check with your Microchip Sales Office for package availability with the Tape and Reel option. Reel size is 3,000.

### Automotive Ordering Code

<u>PART NO.</u>	<u>X</u> <sup>(2)</sup>	-	<u>X</u>	/	<u>XX</u>	-	<u>XXX</u>	<b>Example:</b>
Device	Tape and Reel		Temp.		Package		Automotive Code	
Device:								a) USB3740T-I/ML-V01 Tape & Reel 10-pin QFN RoHS Compliant package (1.6mm x 2.1mm, 0.5mm pitch), Automotive
Tape and Reel:	T							<b>Note 2:</b> Tape and Reel identifier only appears in the catalog part number description. This identifier is used for ordering purposes and is not printed on the device package. Check with your Microchip Sales Office for package availability with the Tape and Reel option. Reel size is 3,000.
Temperature:			I					
Package:					ML			
Automotive Code:							V01	

---

**Note the following details of the code protection feature on Microchip devices:**

- Microchip products meet the specification contained in their particular Microchip Data Sheet.
- Microchip believes that its family of products is one of the most secure families of its kind on the market today, when used in the intended manner and under normal conditions.
- There are dishonest and possibly illegal methods used to breach the code protection feature. All of these methods, to our knowledge, require using the Microchip products in a manner outside the operating specifications contained in Microchip's Data Sheets. Most likely, the person doing so is engaged in theft of intellectual property.
- Microchip is willing to work with the customer who is concerned about the integrity of their code.
- Neither Microchip nor any other semiconductor manufacturer can guarantee the security of their code. Code protection does not mean that we are guaranteeing the product as “unbreakable.”

Code protection is constantly evolving. We at Microchip are committed to continuously improving the code protection features of our products. Attempts to break Microchip's code protection feature may be a violation of the Digital Millennium Copyright Act. If such acts allow unauthorized access to your software or other copyrighted work, you may have a right to sue for relief under that Act.

---

Information contained in this publication regarding device applications and the like is provided only for your convenience and may be superseded by updates. It is your responsibility to ensure that your application meets with your specifications. MICROCHIP MAKES NO REPRESENTATIONS OR WARRANTIES OF ANY KIND WHETHER EXPRESS OR IMPLIED, WRITTEN OR ORAL, STATUTORY OR OTHERWISE, RELATED TO THE INFORMATION, INCLUDING BUT NOT LIMITED TO ITS CONDITION, QUALITY, PERFORMANCE, MERCHANTABILITY OR FITNESS FOR PURPOSE. Microchip disclaims all liability arising from this information and its use. Use of Microchip devices in life support and/or safety applications is entirely at the buyer's risk, and the buyer agrees to defend, indemnify and hold harmless Microchip from any and all damages, claims, suits, or expenses resulting from such use. No licenses are conveyed, implicitly or otherwise, under any Microchip intellectual property rights.

**Trademarks**

The Microchip name and logo, the Microchip logo, dsPIC, FlashFlex, flexPWR, JukeBlox, KEELOQ, KEELOQ logo, Kleer, LANCheck, MediaLB, MOST, MOST logo, MPLAB, OptoLyzer, PIC, PICSTART, PIC<sup>32</sup> logo, RightTouch, SpyNIC, SST, SST Logo, SuperFlash and UNI/O are registered trademarks of Microchip Technology Incorporated in the U.S.A. and other countries.

The Embedded Control Solutions Company and mTouch are registered trademarks of Microchip Technology Incorporated in the U.S.A.

Analog-for-the-Digital Age, BodyCom, chipKIT, chipKIT logo, CodeGuard, dsPICDEM, dsPICDEM.net, ECAN, In-Circuit Serial Programming, ICSP, Inter-Chip Connectivity, KleerNet, KleerNet logo, MiWi, MPASM, MPF, MPLAB Certified logo, MPLIB, MPLINK, MultiTRAK, NetDetach, Omniscient Code Generation, PICDEM, PICDEM.net, PICKit, PICTail, RightTouch logo, REAL ICE, SQI, Serial Quad I/O, Total Endurance, TSHARC, USBCheck, VariSense, ViewSpan, WiperLock, Wireless DNA, and ZENA are trademarks of Microchip Technology Incorporated in the U.S.A. and other countries.

SQTP is a service mark of Microchip Technology Incorporated in the U.S.A.

Silicon Storage Technology is a registered trademark of Microchip Technology Inc. in other countries.

GestIC is a registered trademarks of Microchip Technology Germany II GmbH & Co. KG, a subsidiary of Microchip Technology Inc., in other countries.

All other trademarks mentioned herein are property of their respective companies.

© 2011 - 2015, Microchip Technology Incorporated, Printed in the U.S.A., All Rights Reserved.

ISBN: 9781632771148

**QUALITY MANAGEMENT SYSTEM**  
**CERTIFIED BY DNV**  
**== ISO/TS 16949 ==**

*Microchip received ISO/TS-16949:2009 certification for its worldwide headquarters, design and wafer fabrication facilities in Chandler and Tempe, Arizona; Gresham, Oregon and design centers in California and India. The Company's quality system processes and procedures are for its PIC<sup>®</sup> MCUs and dsPIC<sup>®</sup> DSCs, KEELOQ<sup>®</sup> code hopping devices, Serial EEPROMs, microperipherals, nonvolatile memory and analog products. In addition, Microchip's quality system for the design and manufacture of development systems is ISO 9001:2000 certified.*



# MICROCHIP

## Worldwide Sales and Service

### AMERICAS

**Corporate Office**  
2355 West Chandler Blvd.  
Chandler, AZ 85224-6199  
Tel: 480-792-7200  
Fax: 480-792-7277  
Technical Support:  
<http://www.microchip.com/support>  
Web Address:  
[www.microchip.com](http://www.microchip.com)

**Atlanta**  
Duluth, GA  
Tel: 678-957-9614  
Fax: 678-957-1455

**Austin, TX**  
Tel: 512-257-3370

**Boston**  
Westborough, MA  
Tel: 774-760-0087  
Fax: 774-760-0088

**Chicago**  
Itasca, IL  
Tel: 630-285-0071  
Fax: 630-285-0075

**Cleveland**  
Independence, OH  
Tel: 216-447-0464  
Fax: 216-447-0643

**Dallas**  
Addison, TX  
Tel: 972-818-7423  
Fax: 972-818-2924

**Detroit**  
Novi, MI  
Tel: 248-848-4000

**Houston, TX**  
Tel: 281-894-5983

**Indianapolis**  
Noblesville, IN  
Tel: 317-773-8323  
Fax: 317-773-5453

**Los Angeles**  
Mission Viejo, CA  
Tel: 949-462-9523  
Fax: 949-462-9608

**New York, NY**  
Tel: 631-435-6000

**San Jose, CA**  
Tel: 408-735-9110

**Canada - Toronto**  
Tel: 905-673-0699  
Fax: 905-673-6509

### ASIA/PACIFIC

**Asia Pacific Office**  
Suites 3707-14, 37th Floor  
Tower 6, The Gateway  
Harbour City, Kowloon  
Hong Kong  
Tel: 852-2943-5100  
Fax: 852-2401-3431

**Australia - Sydney**  
Tel: 61-2-9868-6733  
Fax: 61-2-9868-6755

**China - Beijing**  
Tel: 86-10-8569-7000  
Fax: 86-10-8528-2104

**China - Chengdu**  
Tel: 86-28-8665-5511  
Fax: 86-28-8665-7889

**China - Chongqing**  
Tel: 86-23-8980-9588  
Fax: 86-23-8980-9500

**China - Dongguan**  
Tel: 86-769-8702-9880

**China - Hangzhou**  
Tel: 86-571-8792-8115  
Fax: 86-571-8792-8116

**China - Hong Kong SAR**  
Tel: 852-2943-5100  
Fax: 852-2401-3431

**China - Nanjing**  
Tel: 86-25-8473-2460  
Fax: 86-25-8473-2470

**China - Qingdao**  
Tel: 86-532-8502-7355  
Fax: 86-532-8502-7205

**China - Shanghai**  
Tel: 86-21-5407-5533  
Fax: 86-21-5407-5066

**China - Shenyang**  
Tel: 86-24-2334-2829  
Fax: 86-24-2334-2393

**China - Shenzhen**  
Tel: 86-755-8864-2200  
Fax: 86-755-8203-1760

**China - Wuhan**  
Tel: 86-27-5980-5300  
Fax: 86-27-5980-5118

**China - Xian**  
Tel: 86-29-8833-7252  
Fax: 86-29-8833-7256

### ASIA/PACIFIC

**China - Xiamen**  
Tel: 86-592-2388138  
Fax: 86-592-2388130

**China - Zhuhai**  
Tel: 86-756-3210040  
Fax: 86-756-3210049

**India - Bangalore**  
Tel: 91-80-3090-4444  
Fax: 91-80-3090-4123

**India - New Delhi**  
Tel: 91-11-4160-8631  
Fax: 91-11-4160-8632

**India - Pune**  
Tel: 91-20-3019-1500

**Japan - Osaka**  
Tel: 81-6-6152-7160  
Fax: 81-6-6152-9310

**Japan - Tokyo**  
Tel: 81-3-6880-3770  
Fax: 81-3-6880-3771

**Korea - Daegu**  
Tel: 82-53-744-4301  
Fax: 82-53-744-4302

**Korea - Seoul**  
Tel: 82-2-554-7200  
Fax: 82-2-558-5932 or  
82-2-558-5934

**Malaysia - Kuala Lumpur**  
Tel: 60-3-6201-9857  
Fax: 60-3-6201-9859

**Malaysia - Penang**  
Tel: 60-4-227-8870  
Fax: 60-4-227-4068

**Philippines - Manila**  
Tel: 63-2-634-9065  
Fax: 63-2-634-9069

**Singapore**  
Tel: 65-6334-8870  
Fax: 65-6334-8850

**Taiwan - Hsin Chu**  
Tel: 886-3-5778-366  
Fax: 886-3-5770-955

**Taiwan - Kaohsiung**  
Tel: 886-7-213-7828

**Taiwan - Taipei**  
Tel: 886-2-2508-8600  
Fax: 886-2-2508-0102

**Thailand - Bangkok**  
Tel: 66-2-694-1351  
Fax: 66-2-694-1350

### EUROPE

**Austria - Wels**  
Tel: 43-7242-2244-39  
Fax: 43-7242-2244-393

**Denmark - Copenhagen**  
Tel: 45-4450-2828  
Fax: 45-4485-2829

**France - Paris**  
Tel: 33-1-69-53-63-20  
Fax: 33-1-69-30-90-79

**Germany - Dusseldorf**  
Tel: 49-2129-3766400

**Germany - Munich**  
Tel: 49-89-627-144-0  
Fax: 49-89-627-144-44

**Germany - Pforzheim**  
Tel: 49-7231-424750

**Italy - Milan**  
Tel: 39-0331-742611  
Fax: 39-0331-466781

**Italy - Venice**  
Tel: 39-049-7625286

**Netherlands - Drunen**  
Tel: 31-416-690399  
Fax: 31-416-690340

**Poland - Warsaw**  
Tel: 48-22-3325737

**Spain - Madrid**  
Tel: 34-91-708-08-90  
Fax: 34-91-708-08-91

**Sweden - Stockholm**  
Tel: 46-8-5090-4654

**UK - Wokingham**  
Tel: 44-118-921-5800  
Fax: 44-118-921-5820

01/27/15

## Looking for pricing, stock, or lifecycle information?

Click below to explore more details on WIN SOURCE:

 [View USB3740B-AI2-TR on WIN SOURCE](#)

 [Microchip Technology](#) Information

## Optimize Your Supply Chain with WIN SOURCE Solutions

-  Global Sourcing Solution
-  Obsolete Management
-  Cost Control Management
-  Shortage Management
-  Alternative Solution
-  Excess Inventory Management