

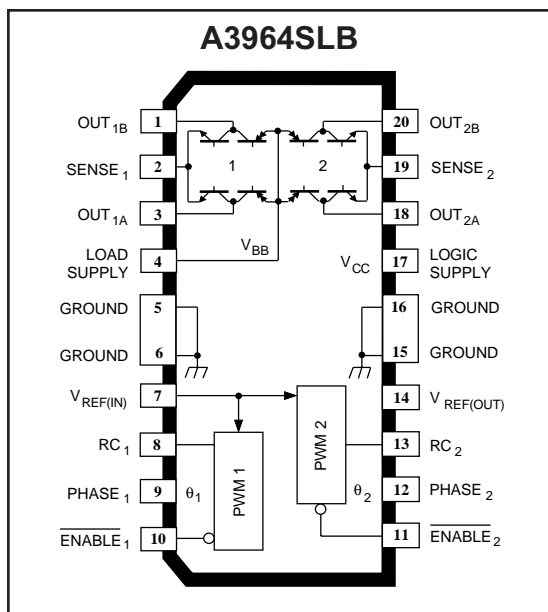

**THE DATASHEET OF
A3964SB**



DUAL FULL-BRIDGE PWM MOTOR DRIVER



Dwg. PP-047-1

ABSOLUTE MAXIMUM RATINGS

Load Supply Voltage, V_{BB}	33 V
Output Current, I_{OUT} (10 μ s)	± 1.0 A*
(continuous)	± 800 mA*
Logic Supply Voltage, V_{CC}	7.0 V
Logic Input Voltage Range, V_{IN}	-0.3 V to $V_{CC} + 0.3$ V
Sense Voltage, V_S	1.0 V
Reference Output Current, $I_{REF(OUT)}$	1.0 mA
Package Power Dissipation, P_D	See Graph
Operating Temperature Range, T_A	-20°C to +85°C
Junction Temperature, T_J	+150°C†
Storage Temperature Range, T_S	-55°C to +150°C

* Output current rating may be limited by duty cycle, ambient temperature, and heat sinking. Under any set of conditions, do not exceed the specified current rating or a junction temperature of 150°C.

† Fault conditions that produce excessive junction temperature will activate the device's thermal shutdown circuitry. These conditions can be tolerated but should be avoided.

Designed for pulse-width modulated (PWM) current control of bipolar stepper motors, the A3964SB and A3964SLB are capable of continuous output currents to ± 800 mA and operating voltages to 30 V. Internal fixed off-time PWM current-control circuitry can be used to regulate the maximum load current to a desired value. An internal precision voltage reference is provided to improve motor peak-current control accuracy. The peak load current limit is set by the user's selection of an external resistor divider and current-sensing resistors.

The fixed off-time pulse duration is set by user-selected external RC timing networks. The capacitor in the RC timing network also determines a user-selectable blanking window that prevents false triggering of the PWM current control circuitry during switching transitions. This eliminates the need for two external RC filter networks on the current-sensing comparator inputs.

For each bridge the PHASE input controls load current polarity by selecting the appropriate source and sink driver pair. For each bridge the ENABLE input, when held high, disables the output drivers. Special power-up sequencing is not required. Internal circuit protection includes thermal shutdown with hysteresis, transient-suppression diodes, and crossover-current protection.

The A3964SB is supplied in a 24-pin plastic DIP with copper heat sink tabs; A3964SLB is supplied in a 20-lead plastic SOIC with copper heat sink tabs. The power tabs are at ground potential and need no electrical isolation.

FEATURES

- ± 800 mA Continuous Output Current Rating
- 30 V Output Voltage Rating
- Internal PWM Current Control, Saturated Sink Drivers
- Internally Generated, Precision 2.5 V Reference
- Internal Transient-Suppression Diodes
- Internal Thermal-Shutdown Circuitry
- Crossover-Current Protection, UVLO Protection

Always order by complete part number:

Part Number	Package
A3964SB	24-Pin DIP
A3964SLB	20-Lead Wide-Body SOIC

3964 DUAL FULL-BRIDGE PWM MOTOR DRIVER

A3964SB

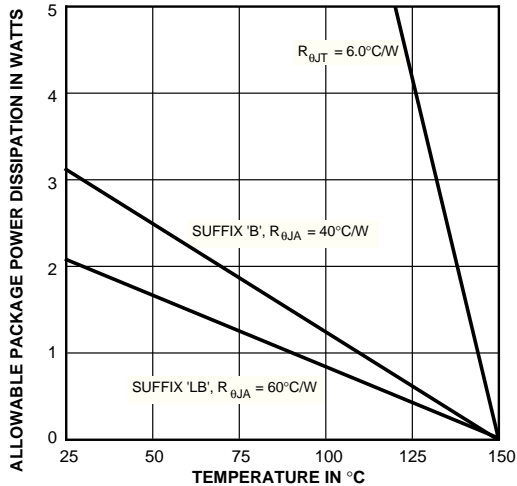

Dwg. GP-049-4

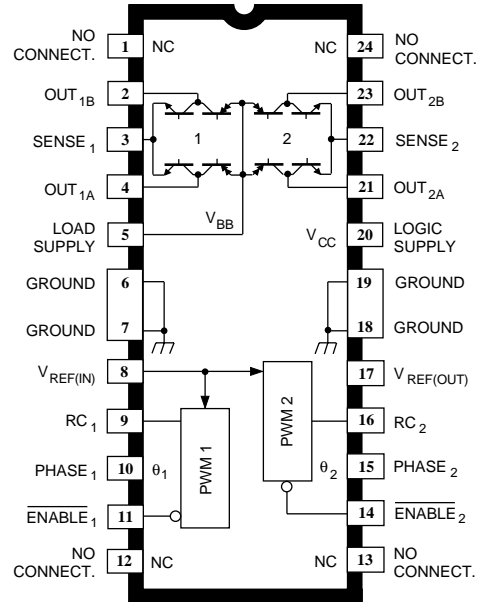

Dwg. PP-005-2

FUNCTIONAL BLOCK DIAGRAM (A3964SLB pinning shown)

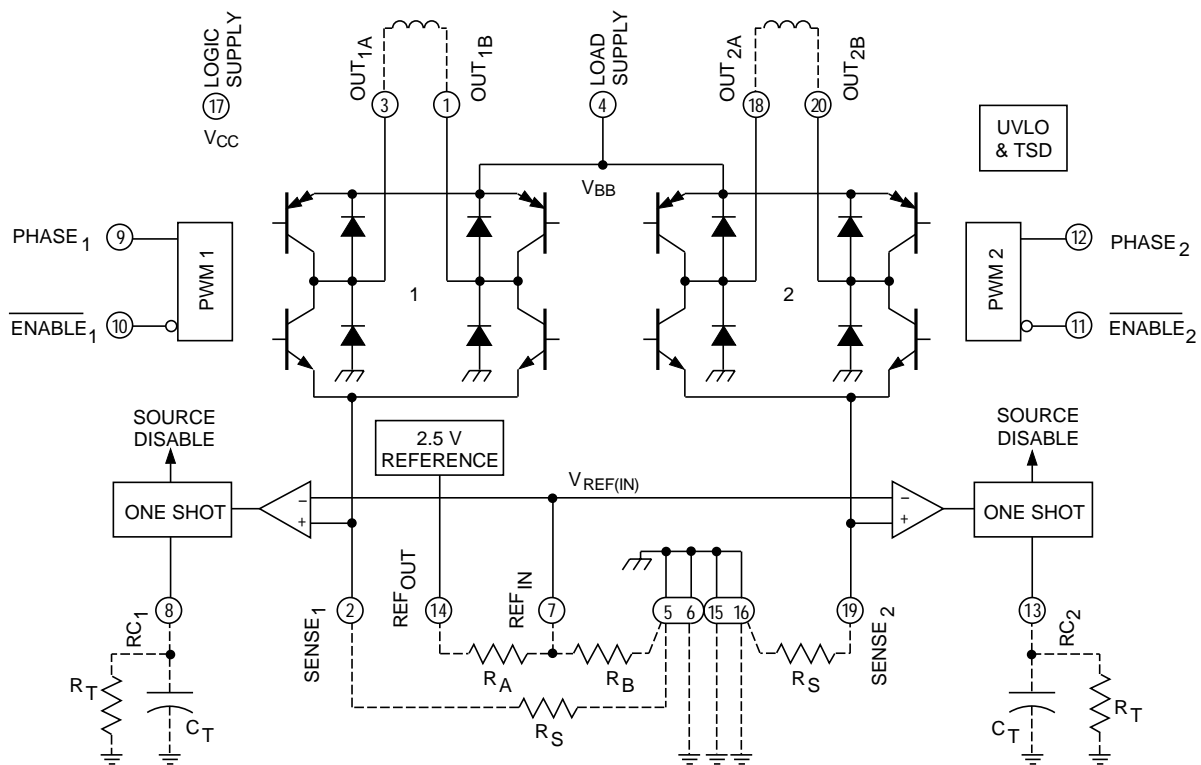

Dwg. FP-033-1



115 Northeast Cutoff, Box 15036
Worcester, Massachusetts 01615-0036 (508) 853-5000
Copyright © 1997 Allegro MicroSystems, Inc.

3964

DUAL FULL-BRIDGE PWM MOTOR DRIVER

TRUTH TABLE

ENABLE	PHASE	OUT _A	OUT _B
H	X	Off	Off
L	H	H	L
L	L	L	H

X = Irrelevant

ELECTRICAL CHARACTERISTICS at T_A = +25°C, V_{BB} = 30 V, V_{CC} = 4.75 V to 5.25 V, V_S = 0 V, 30 kΩ & 1000 pF RC to Ground (unless noted otherwise)

Characteristic	Symbol	Test Conditions	Limits			
			Min.	Typ.	Max.	Units

Output Drivers

Load Supply Voltage Range	V _{BB}	Operating, I _{OUT} = ±800 mA, L = 3 mH	5.0	—	30	V
Output Sustaining Voltage	V _{CE(sus)}	I _{OUT} = ±800 mA, L = 3 mH, V _{BB} = 33 V	33	—	—	V
Output Leakage Current	I _{CEX}	V _{OUT} = V _{BB} = 33 V	—	<1.0	50	μA
		V _{OUT} = 0 V, V _{BB} = 33 V	—	<1.0	-50	μA
Output Saturation Voltage	V _{CE(SAT)}	Source Driver, I _{OUT} = -500 mA	—	1.0	1.2	V
		Source Driver, I _{OUT} = -750 mA	—	1.1	1.5	V
		Source Driver, I _{OUT} = -800 mA	—	—	1.7	V
		Sink Driver, I _{OUT} = +500 mA	—	0.3	0.6	V
		Sink Driver, I _{OUT} = +750 mA	—	0.5	1.2	V
		Sink Driver, I _{OUT} = +800 mA	—	—	1.5	V
Clamp Diode Forward Voltage (Sink or Source)	V _F	I _F = 500 mA	—	1.1	1.4	V
		I _F = 750 mA	—	1.3	1.6	V
		I _F = 800 mA	—	—	1.7	V
Motor Supply Current (No Load)	I _{BB(ON)}	V _{ENABLE} = 0.8 V	—	2.0	4.0	mA
	I _{BB(OFF)}	V _{ENABLE} = 2.4 V	—	0	500	μA

NOTES: 1. Typical Data is for design information only.
2. Negative current is defined as coming out of (sourcing) the specified device terminal.

3964

DUAL FULL-BRIDGE PWM MOTOR DRIVER

ELECTRICAL CHARACTERISTICS at $T_A = +25^\circ\text{C}$, $V_{BB} = 30\text{ V}$, $V_{CC} = 4.75\text{ V to }5.25\text{ V}$, $V_{SENSE} = 0\text{ V}$, $30\text{ k}\Omega$ & $1000\text{ pF RC to Ground}$ (unless noted otherwise) (cont.)

Characteristic	Symbol	Test Conditions	Limits			
			Min.	Typ.	Max.	Units
Control Logic						
Logic Supply Voltage Range	V_{CC}	Operating	4.75	—	5.25	V
Logic Input Voltage	$V_{IN(1)}$		2.4	—	—	V
	$V_{IN(0)}$		—	—	0.8	V
Logic Input Current	$I_{IN(1)}$	$V_{IN} = 2.4\text{ V}$	—	<1.0	20	μA
	$I_{IN(0)}$	$V_{IN} = 0.8\text{ V}$	—	<-2.0	-200	μA
Reference Output Voltage	$V_{REF(OUT)}$	$V_{CC} = 5.0\text{ V}$, $I_{REF(OUT)} = 90\text{ to }900\ \mu\text{A}$	2.45	2.50	2.55	V
Reference Output Current	$I_{REF(OUT)}$	$3\text{ k}\Omega \leq R_D = R_A + R_B \leq 15\text{ k}\Omega$	150	—	900	μA
Ref. Input Offset Current	I_{OS}	$V_{REF(IN)} = 1\text{ V}$	-2.5	0	1.0	μA
Comparator Input Offset Volt.	V_{IO}	$V_{REF(IN)} = 0\text{ V}$	-6.0	0	6.0	mV
Comparator Input Volt. Range	V_{REF}	Operating	-0.3	—	1.0	V
PWM RC Fixed Off-time	$t_{OFF\ RC}$	$C_T = 1000\text{ pF}$, $R_T = 30\text{ k}\Omega$	27	30	33	μs
PWM Propagation Delay Time	t_{PWM}	Comparator Trip to Source OFF	—	1.2	2.0	μs
PWM Minimum On Time	$t_{ON(min)}$	$C_T = 1000\text{ pF}$, $R_T \geq 15\text{ k}\Omega$, $V_{CC} = 5\text{ V}$	—	2.5	3.6	μs
Propagation Delay Times	t_{pd}	$I_{OUT} = \pm 800\text{ mA}$, 50% to 90%: ENABLE ON to Source ON	—	3.2	—	μs
		ENABLE OFF to Source OFF	—	1.2	—	μs
		ENABLE ON to Sink ON	—	3.2	—	μs
		ENABLE OFF to Sink OFF	—	0.7	—	μs
		PHASE Change to Sink ON	—	3.2	—	μs
		PHASE Change to Source ON	—	3.2	—	μs
		PHASE Change to Sink OFF	—	0.7	—	μs
		PHASE Change to Source OFF	—	1.2	—	μs
Thermal Shutdown Temp.	T_J		—	165	—	$^\circ\text{C}$
Thermal Shutdown Hysteresis	ΔT_J		—	15	—	$^\circ\text{C}$
UVLO Disable Threshold		Decreasing V_{CC}	4.20	4.40	4.65	V
UVLO Hysteresis		UVLO Enable Volt. - UVLO Disable Volt.	0.075	0.125	0.175	V
UVLO Enable Threshold		Increasing V_{CC}	4.375	4.525	4.725	V
Logic Supply Current	$I_{CC(ON)}$	$V_{ENABLE\ 1} = V_{ENABLE\ 2} = 0.8\text{ V}$	—	60	85	mA
	$I_{CC(OFF)}$	$V_{ENABLE\ 1} = V_{ENABLE\ 2} = 2.4\text{ V}$	—	13	17	mA
Logic Supply Current Temperature Coefficient	$\Delta I_{CC(ON)}$	$V_{ENABLE\ 1} = V_{ENABLE\ 2} = 0.8\text{ V}$	—	0.18	—	mA/ $^\circ\text{C}$

NOTES: 1. Typical Data is for design information only.
2. Negative current is defined as coming out of (sourcing) the specified device terminal.



115 Northeast Cutoff, Box 15036
Worcester, Massachusetts 01615-0036 (508) 853-5000

FUNCTIONAL DESCRIPTION

Internal PWM Current Control. The A3964SB and A3964SLB contain a fixed off-time pulse-width modulated (PWM) current-control circuit that can be used to limit the load current to a desired value. The peak value of the current limiting (I_{TRIP}) is set by the selection of an external current-sensing resistor (R_S) and reference input voltage ($V_{REF(IN)}$). The internal circuitry compares the voltage across the external sense resistor to the voltage on the reference input terminal ($V_{REF(IN)}$) resulting in a transconductance function approximated by:

$$I_{TRIP} \approx \frac{V_{REF(IN)}}{R_S}$$

The reference input voltage is typically set with a resistor divider from $V_{REF(OUT)}$. To ensure proper operation of the voltage reference, the resistor divider should have an impedance of 3 k Ω to 15 k Ω ($R_D = R_A + R_B$). Within this range, a low impedance will minimize the effect of the REF IN input offset current.

The current-control circuitry limits the load current as follows: when the load current reaches I_{TRIP} , the comparator resets a latch that turns off the selected source driver. The load inductance causes the current to recirculate through the sink driver and flyback diode.

For each bridge, the user selects an external resistor (R_T) and capacitor (C_T) to determine the time period ($t_{OFF} = R_T C_T$) during which the source driver remains disabled (see "RC Fixed Off-time" below). The range of recommended values for C_T and R_T are 1000 pF to 1500 pF and 15 k Ω to 100 k Ω respectively. For optimal load current regulation, C_T is normally set to 1000 pF (see "Load Current Regulation" below). At the end of the RC interval, the source driver is enabled allowing the load current to increase again. The PWM cycle repeats, maintaining the peak load current at the desired value.

RC Blanking. In addition to determining the fixed off-time of the PWM control circuit, the C_T component sets the comparator blanking time. This function blanks the output of the comparator when the outputs are switched by the internal current-control circuitry (or by the PHASE or ENABLE inputs). The comparator output is blanked to

prevent false over-current detections due to reverse-recovery currents of the clamp diodes, and/or switching transients related to distributed capacitance in the load.

During internal PWM operation, at the end of the t_{OFF} time, the comparator's output is blanked and C_T begins to be charged from approximately 1.1 volts by an internal current source of approximately 1 mA. The comparator output remains blanked until the voltage on C_T reaches approximately 3 volts.

When a transition of the PHASE input occurs, C_T is discharged to near ground during the crossover delay time (the crossover delay time is present to prevent simultaneous conduction of the source and sink drivers). After the crossover delay, C_T is charged by an internal current source of approximately 1 mA. The comparator output remains blanked until the voltage on C_T reaches approximately 3 volts.

When the device is disabled, via the ENABLE input, C_T is discharged to near ground. When the device is re-enabled, C_T is charged by an internal current source of approximately 1 mA. The comparator output remains blanked until the voltage on C_T reaches approximately 3 volts.

The minimum recommended value for C_T is 1000 pF. This value ensures that the blanking time is sufficient to avoid false trips of the comparator under normal operating conditions. For optimal regulation of the load current, the above value for C_T is recommended and the value of R_T can be sized to determine t_{OFF} . For more information regarding load current regulation, see below.

Load Current Regulation. Because the device operates in a slow current-decay mode (2-quadrant PWM mode), there is a limit to the lowest level that the PWM current control circuitry can regulate load current. The limitation is due to the minimum PWM duty cycle, which is a function of the user-selected value of t_{OFF} and the minimum on-time pulse $t_{ON(min)max}$ that occurs each time the PWM latch is reset. If the motor is not rotating, as in the case of a stepper motor in hold/detent mode, a brush dc motor when stalled or at startup, the worst case value of current regulation can be approximated by:

$$I_{AVG} \approx \frac{[(V_{BB} - V_{SAT(SOURCE+SINK)}) \cdot t_{ON(min)max}] - (1.05 (V_{SAT(SINK)} + V_F) \cdot t_{OFF})}{1.05 (t_{ON(min)max} + t_{OFF}) \cdot R_{LOAD}}$$

where $t_{OFF} = R_T C_T$, R_{LOAD} is the series resistance of the load, V_{BB} is the motor supply voltage and $t_{ON(min)max}$ is specified in the electrical characteristics table. When the motor is rotating, the back EMF generated will influence the above relationship. For brush dc motor applications, the current regulation is improved. For stepper motor applications when the motor is rotating, the effect is dependent on the polarity and magnitude of the motor's back EMF.

The following procedure can be used to evaluate the worst case internal PWM load current regulation in the system:

Set $V_{REF(IN)}$ to 0 volts. With the load connected and the PWM current control operating in slow decay mode, use an oscilloscope to measure the time the output is low (sink ON) for the output that is chopping. This is the typical minimum on time ($t_{ON(min)typ}$) for the device. The C_T then should be increased until the measured value of $t_{ON(min)}$ is equal to $t_{ON(min)max}$ as specified in the electrical characteristics table. When the new value of C_T has been set, the value of R_T should be decreased so the value for $t_{OFF} = R_T C_T$ (with the artificially increased value of C_T) is equal to the nominal design value. The worst-case load-current regulation then can be measured in the system under operating conditions.

PWM of the Phase and Enable Inputs. The PHASE and ENABLE inputs can be pulse width modulated to regulate load current. Typical propagation delays from the PHASE and ENABLE inputs to transitions of the power outputs are specified in the electrical characteristics table. If the internal PWM current control is used, the comparator blanking function is active during phase and enable transitions. This eliminates false tripping of the over-current comparator caused by switching transients (see "RC Blanking" above).

Enable PWM. Toggling the ENABLE input turns ON and OFF the selected source and sink drivers. The corresponding pair of flyback and ground clamp diodes conduct after the drivers are disabled, resulting in fast current decay. When the device is enabled the internal current control circuitry will be active and can be used to limit the load current in a slow current-decay mode.

Phase PWM. Toggling the PHASE terminal selects which sink/source pair is enabled, producing a load current that varies with the duty cycle and remains continuous at all times. This can have added benefits in bidirectional brush

dc servo motor applications as the transfer function between the duty cycle on the PHASE input and the average voltage applied to the motor is more linear than in the case of ENABLE PWM control (which produces a discontinuous current at low current levels).

Miscellaneous Information. An internally generated dead time prevents crossover currents that can occur when switching phase.

Thermal protection circuitry turns OFF all drivers should the junction temperature reach +165°C (typical). This is intended only to protect the device from failures due to excessive junction temperatures and should not imply that output short circuits are permitted. The hysteresis of the thermal shutdown circuit is approximately 15°C.

APPLICATION NOTES

Current Sensing. The actual peak load current (I_{PEAK}) will be above the calculated value of I_{TRIP} due to delays in the turn off of the drivers. The amount of overshoot can be approximated by:

$$I_{OS} \approx \frac{(V_{BB} - [(I_{TRIP} \cdot R_{LOAD}) + V_{BEMF}]) \cdot t_{PWM}}{L_{LOAD}}$$

where V_{BB} is the motor supply voltage, V_{BEMF} is the back-EMF voltage of the load, R_{LOAD} and L_{LOAD} are the resistance and inductance of the load respectively, and t_{PWM} is specified in the electrical characteristics table.

To minimize current sensing inaccuracies caused by ground trace IR drops, each current-sensing resistor should have a separate return to the ground terminal of the device. For low-value sense resistors, the IR drops in the PCB can be significant and should be taken into account. The use of sockets should be avoided as their contact resistance can cause variations in the effective value of R_S .

Generally, larger values of R_S reduce the aforementioned effects but can result in excessive heating and power loss in the sense resistor. The selected value of R_S should not cause the absolute maximum voltage rating of 1.0 V, for the SENSE terminal, to be exceeded. The recommended value of R_S is in the range of:

$$R_S \approx \frac{0.5}{I_{TRIPmax}} \pm 50\%$$

If desired, the reference input voltage can be filtered by placing a capacitor from REF_{IN} to ground. The ground return for this capacitor as well as R_B should be independent from the high-current power-ground trace to avoid changes in REF_{IN} due to IR drops.

Thermal Considerations. For reliable operation, it is recommended that the maximum junction temperature be kept below 110°C to 125°C. The junction temperature can be measured best by attaching a thermocouple to the power tab/batwing of the device and measuring the tab temperature, T_{TAB} . The junction temperature can then be approximated by using the formula:

$$T_J \approx T_{TAB} + (2 I_{LOAD} V_F R_{\theta JT})$$

where V_F can be chosen from the electrical specification table for the given level of I_{LOAD} . The value for $R_{\theta JT}$ is approximately 6°C/W for both package styles.

The power dissipation of the batwing packages can be improved by 20 to 30% by adding a section of printed circuit board copper (typically 6 to 18 square centimeters) connected to the batwing terminals of the device.

The thermal performance in applications that run at high load currents and/or high duty cycles can be improved by adding external diodes from each output to ground in parallel with the internal diodes. Fast-recovery (≤ 200 ns) diodes should be used to minimize switching losses.

The load supply terminal, V_{BB} , should be decoupled with an electrolytic capacitor ($\geq 47 \mu F$ is recommended) placed as close to the device as is physically practical. To minimize the effect of system ground IR drops on the logic and reference input signals the system ground should have a low-resistance return to the load supply voltage.

See also “Current Sensing” and “Thermal Considerations” above.

Fixed Off-Time Selection. With increasing values of t_{OFF} , switching losses will decrease, low-level load current regulation will improve, EMI will be reduced, the PWM frequency will decrease, and ripple current will increase. The value of t_{OFF} can be chosen for optimization of these parameters. For applications where audible noise is a concern, typical values of t_{OFF} are chosen to be in the range of 15 to 35 μs .

3964

DUAL FULL-BRIDGE PWM MOTOR DRIVER

A3964SB

Dimensions in Inches
(controlling dimensions)

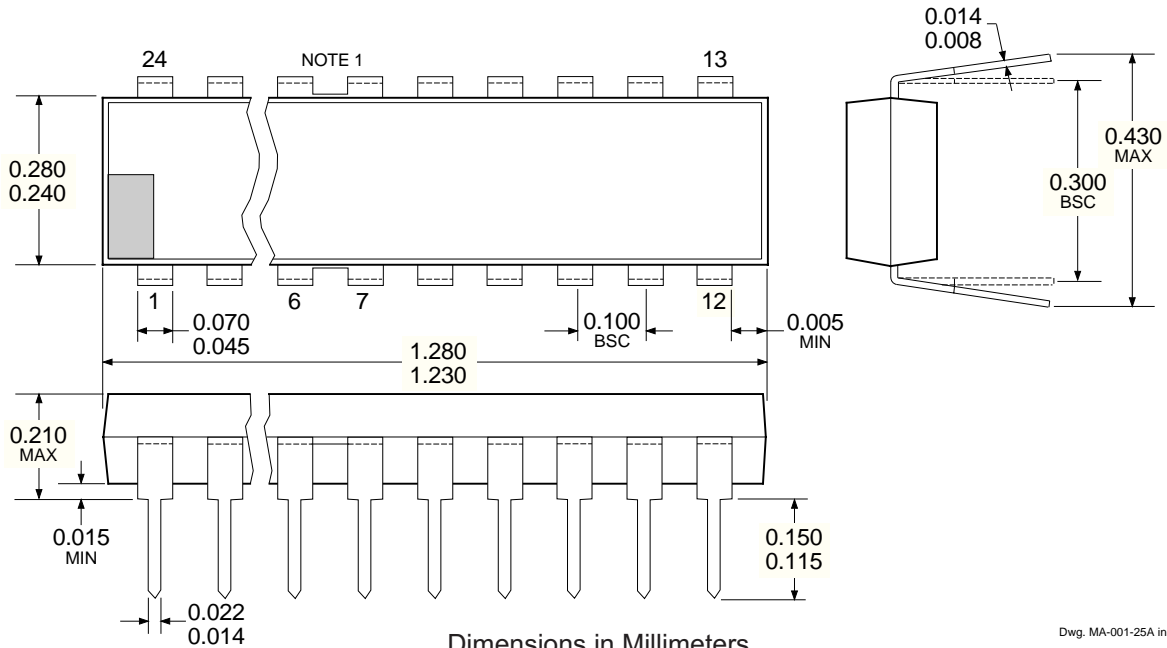

Dwg. MA-001-25A in

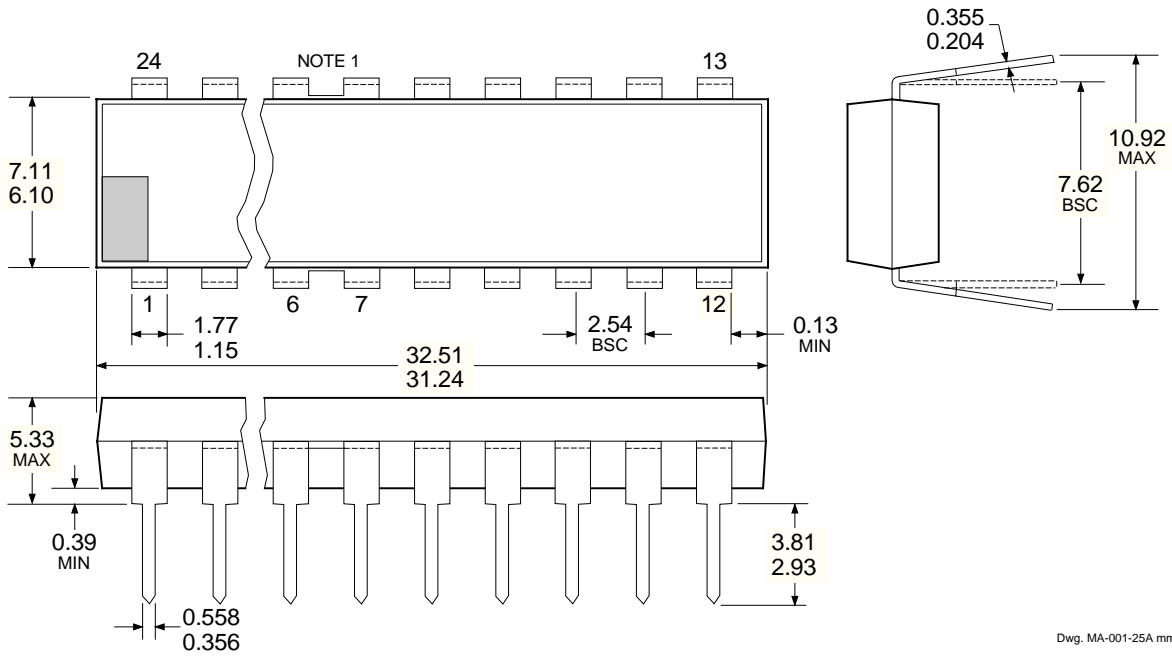

- NOTES: 1. Webbed lead frame. Leads 6, 7, 18, and 19 are internally one piece.
 2. Lead spacing tolerance is non-cumulative.
 3. Exact body and lead configuration at vendor's option within limits shown.
 4. Lead thickness is measured at seating plane or below.



115 Northeast Cutoff, Box 15036
 Worcester, Massachusetts 01615-0036 (508) 853-5000

3964

DUAL FULL-BRIDGE PWM MOTOR DRIVER

A3964SLB

Dimensions in Inches
(for reference only)

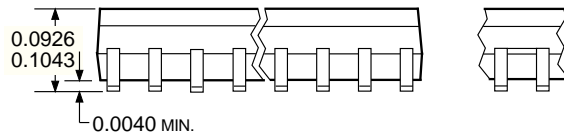
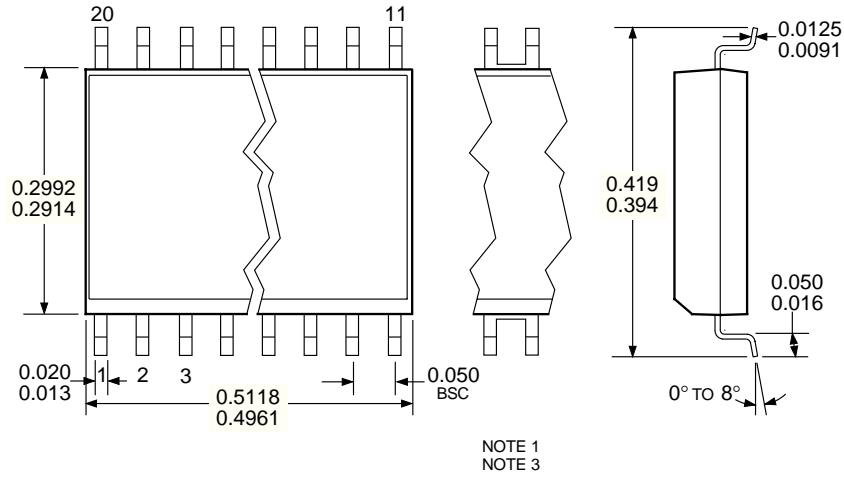

Dwg. MA-008-21A in

Dimensions in Millimeters (controlling dimensions)

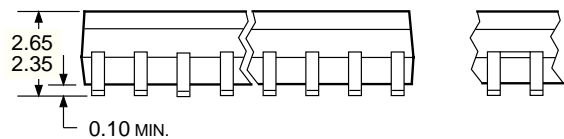
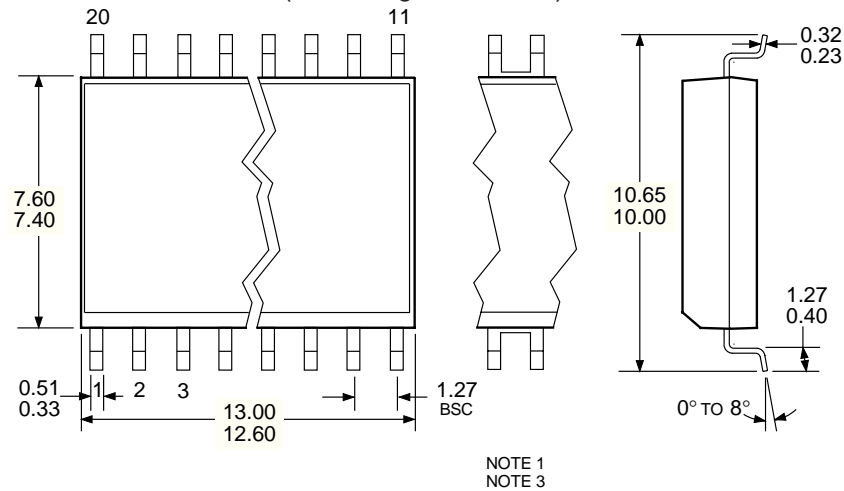

Dwg. MA-008-21A mm

- NOTES: 1. Webbed lead frame. Leads 5, 6, 15, and 16 are internally one piece.
2. Lead spacing tolerance is non-cumulative.
3. Exact body and lead configuration at vendor's option within limits shown.

MOTOR DRIVERS SELECTION GUIDE

Function	Output Ratings *		Part Number †
INTEGRATED CIRCUITS FOR BRUSHLESS DC MOTORS			
3-Phase Controller/Drivers	±2.0 A	45 V	2936 and 2936-120
Hall-Effect Latched Sensors	10 mA	24 V	3175 and 3177
2-Phase Hall-Effect Sensor/Controller	20 mA	25 V	3235
Hall-Effect Complementary-Output Sensor	20 mA	25 V	3275
2-Phase Hall-Effect Sensor/Driver	900 mA	14 V	3625
2-Phase Hall-Effect Sensor/Driver	400 mA	26 V	3626
Hall-Effect Complementary-Output Sensor/Driver	300 mA	60 V	5275
3-Phase Back-EMF Controller/Driver	±900 mA	14 V	8902-A
3-Phase Controller/DMOS Driver	±4.0 A	14 V	8925
3-Phase Back-EMF Controller/Driver	±1.0 A	7 V	8984
INTEGRATED BRIDGE DRIVERS FOR DC AND BIPOLAR STEPPER MOTORS			
PWM Current-Controlled Dual Full Bridge	±750 mA	45 V	2916
PWM Current-Controlled Dual Full Bridges	±1.5 A	45 V	2917 and 2918
PWM Current-Controlled Dual Full Bridge	±750 mA	45 V	2919
Dual Full-Bridge Driver	±2.0 A	50 V	2998
PWM Current-Controlled Full Bridge	±2.0 A	50 V	3952
PWM Current-Controlled Full Bridge	±1.3 A	50 V	3953
PWM Current-Controlled Microstepping Full Bridges	±1.5 A	50 V	3955 and 3957
PWM Current-Controlled Dual Full Bridge	±800 mA	33 V	3964
PWM Current-Controlled Dual Full Bridge	±650 mA	30 V	3966 and 3968
PWM Current-Controlled Dual Full Bridge	±750 mA	45 V	6219
OTHER INTEGRATED CIRCUIT & PMCM MOTOR DRIVERS			
Unipolar Stepper-Motor Quad Driver	1.8 A	50 V	2544
Unipolar Stepper-Motor Translator/Driver	1.25 A	50 V	5804
Unipolar Stepper-Motor Quad Drivers	1 A	46 V	7024 and 7029
Unipolar Microstepper-Motor Quad Driver	1.2 A	46 V	7042
Voice-Coil Motor Driver	±500 mA	6 V	8932-A
Voice-Coil Motor Driver	±800 mA	16 V	8958
Voice-Coil (and Spindle) Motor Driver	±350 mA	7 V	8984

* Current is maximum specified test condition, voltage is maximum rating. See specification for sustaining voltage limits or over-current protection voltage limits. Negative current is defined as coming out of (sourcing) the output.

† Complete part number includes additional characters to indicate operating temperature range and package style.

Allegro MicroSystems, Inc. reserves the right to make, from time to time, such departures from the detail specifications as may be required to permit improvements in the design of its products. Components made under military approvals will be in accordance with the approval requirements.

The information included herein is believed to be accurate and reliable. However, Allegro MicroSystems, Inc. assumes no responsibility for its use; nor for any infringements of patents or other rights of third parties which may result from its use.



Looking for pricing, stock, or lifecycle information?

Click below to explore more details on WIN SOURCE:

- ⊖ [View A3964SB](#) on WIN SOURCE
- ⊖ [Allegro MicroSystems, LLC](#) Information

Optimize Your Supply Chain with WIN SOURCE Solutions

- ✓ Global Sourcing Solution
- ✓ Obsolete Management
- ✓ Cost Control Management
- ✓ Shortage Management
- ✓ Alternative Solution
- ✓ Excess Inventory Management