



THE DATASHEET OF ULN2003LVDR



ULN2003LV 7-Channel Relay and Inductive Load Sink Driver

1 Features

- 7-Channel High Current Sink Drivers
- Supports up to 8V Output Pullup Voltage
- Supports a Wide Range of 3V-to-5V Relay and Inductive Coils
- Low Output VOL of 0.4V (Typical) With
 - 100mA (Typical) Current Sink per Channel at 3.3V Logic Input⁽¹⁾
 - 140mA (Typical) Current Sink per Channel at 5.0V Logic Input⁽¹⁾
- Compatible to 3.3V and 5.0V Microcontrollers and Logic Interface
- Internal Free-Wheeling Diodes for Inductive Kick-back Protection
- Input Pulldown Resistors Allow 3-stating the Input Driver
- Input RC-Snubber to Eliminate Spurious Operation in Noisy Environment
- Low Input and Output Leakage Currents
- Easy to use Parallel Interface
- ESD Protection Exceeds JESD 22
 - 2kV HBM, 500V CDM
- Available in 16-Pin SOIC and TSSOP Packages

⁽¹⁾ Total current sink may be limited by the internal junction temperature, absolute maximum current levels etc - refer to the Electrical Specifications section for details.

2 Applications

- Relay and Inductive Load Driver in Various Telecom, Consumer, and Industrial Applications
- Lamp and LED Displays
- Logic Level Shifter

3 Description

The ULN2003LV is a low-voltage and low power upgrade of TI's popular ULN2003 family of 7-channel Darlington transistor array. The ULN2003LV sink driver features 7 low output impedance drivers to support low voltage relay and inductive coil applications. The low impedance drivers minimize on-chip power dissipation; up to 5 times lower for typical 3V relays. The ULN2003LV driver is pin-to-pin compatible with ULN2003 family of devices in similar packages.

The ULN2003LV supports 3.3V to 5V CMOS logic input interface thus making it compatible to a wide range of micro-controllers and other logic interfaces. The ULN2003LV features an improved input interface that minimizes the input DC current drawn from the external drivers. The ULN2003LV features an input RC snubber that greatly improves its performance in noisy operating conditions. The ULN2003LV channel inputs feature an internal input pull-down resistor thus allowing input logic to be tri-stated. The ULN2003LV may also support other logic input levels, for example, TTL and 1.8V, refer to the [Application Information](#) section for details.

The ULN2003LV provides flexibility of increasing current sink capability through combining several adjacent channels in parallel. Under typical conditions the ULN2003LV can support up to 1.0A of load current when all 7-channels are connected in parallel. The ULN2003LV can also be used in a variety of applications requiring a sink drivers like driving LEDs and Logic Level Shifting.

Device Information⁽¹⁾

PART NUMBER	PACKAGE	BODY SIZE (NOM)
ULN2003LVDR	SOIC (16)	3.90 mm x 9.90 mm
ULN2003LVPWR	TSSOP (16)	4.40 mm x 5.00 mm

⁽¹⁾ For all available packages, see the orderable addendum at the end of the data sheet.

Simplified Function Diagram

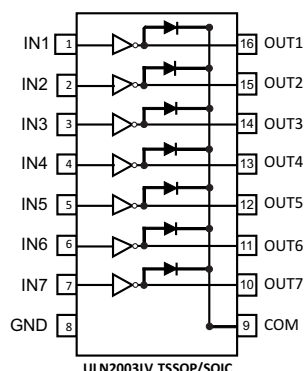

Table of Contents

1 Features	1	7.4 Device Functional Modes.....	9
2 Applications	1	8 Application and Implementation	10
3 Description	1	8.1 Application Information.....	10
4 Revision History	2	8.2 Typical Application	10
5 Pin Configuration and Functions	3	8.3 System Examples	12
6 Specifications	4	9 Power Supply Recommendations	16
6.1 Absolute Maximum Ratings	4	10 Layout	16
6.2 ESD Ratings	4	10.1 Layout Guidelines	16
6.3 Recommended Operating Conditions.....	4	10.2 Layout Example	16
6.4 Thermal Information	4	10.3 On-Chip Power Dissipation.....	16
6.5 Electrical Characteristics.....	5	10.4 Thermal Considerations	17
6.6 Switching Characteristics	6	11 Device and Documentation Support	18
6.7 Dissipation Ratings	6	11.1 Community Resources.....	18
6.8 Typical Characteristics	7	11.2 Trademarks	18
7 Detailed Description	8	11.3 Electrostatic Discharge Caution.....	18
7.1 Overview	8	11.4 Glossary	18
7.2 Functional Block Diagram	8	12 Mechanical, Packaging, and Orderable	
7.3 Feature Description	8	Information	18

4 Revision History

NOTE: Page numbers for previous revisions may differ from page numbers in the current version.

Changes from Revision A (April 2012) to Revision B	Page
<ul style="list-style-type: none"> Added <i>Pin Configuration and Functions</i> section, <i>ESD Ratings</i> table, <i>Feature Description</i> section, <i>Device Functional Modes</i>, <i>Application and Implementation</i> section, <i>Power Supply Recommendations</i> section, <i>Layout</i> section, <i>Device and Documentation Support</i> section, and <i>Mechanical, Packaging, and Orderable Information</i> section 	1

5 Pin Configuration and Functions

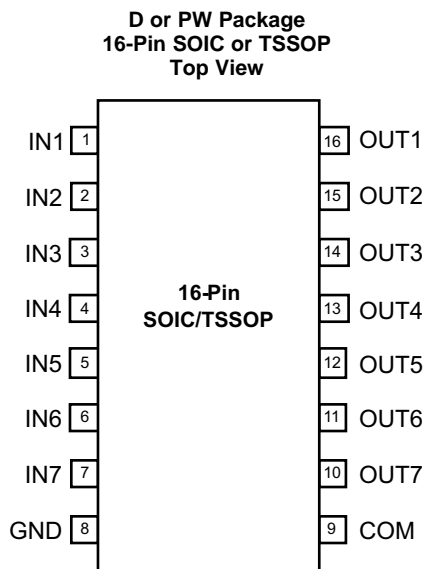

Pin Functions

PIN		TYPE	DESCRIPTION
NAME	NO.		
IN1	1	Input	Logic Input Pins IN1 through IN7
IN2	2	Input	
IN3	3	Input	
IN4	4	Input	
IN5	5	Input	
IN6	6	Input	
IN7	7	Input	
GND	8	Ground	Ground Reference Pin
COM	9	Output	Internal Free-Wheeling Diode Common Cathode Pin
OUT7	10	Output	Channel Output Pins OUT7 through OUT1
OUT6	11	Output	
OUT5	12	Output	
OUT4	13	Output	
OUT3	14	Output	
OUT2	15	Output	
OUT1	16	Output	

6 Specifications

6.1 Absolute Maximum Ratings

 Specified at $T_J = -40^{\circ}\text{C}$ to 125°C unless otherwise noted. ⁽¹⁾

		MIN	MAX	UNIT	
V_{IN}	Pins IN1- IN7 to GND voltage	-0.3	5.5	V	
V_{OUT}	Pins OUT1 – OUT7 to GND voltage		8	V	
V_{COM}	Pin COM to GND voltage		8	V	
I_{GND}	Maximum GND-pin continuous current ($T_J > +125^{\circ}\text{C}$)		700	mA	
	Maximum GND-pin continuous current ($T_J < +100^{\circ}\text{C}$)		1.0	A	
P_D	Total device power dissipation at $T_A = 85^{\circ}\text{C}$	16 Pin - SOIC		0.58	W
		16 Pin -TSSOP		0.45	W
T_A	Operating free-air ambient temperature	-40	85	$^{\circ}\text{C}$	
T_J	Operating virtual junction temperature	-55	150	$^{\circ}\text{C}$	
T_{stg}	Storage temperature	-55	150	$^{\circ}\text{C}$	

(1) Stresses beyond those listed under *Absolute Maximum Ratings* may cause permanent damage to the device. These are stress ratings only, which do not imply functional operation of the device at these or any other conditions beyond those indicated under *Recommended Operating Conditions*. Exposure to absolute-maximum-rated conditions for extended periods may affect device reliability.

6.2 ESD Ratings

		VALUE	UNIT
$V_{(ESD)}$	Electrostatic discharge	Human body model (HBM), per ANSI/ESDA/JEDEC JS-001 ⁽¹⁾	± 2000
		Charged-device model (CDM), per JEDEC specification JESD22-C101 ⁽²⁾	± 500

(1) JEDEC document JEP155 states that 500-V HBM allows safe manufacturing with a standard ESD control process.

(2) JEDEC document JEP157 states that 250-V CDM allows safe manufacturing with a standard ESD control process.

6.3 Recommended Operating Conditions

over operating free-air temperature range (unless otherwise noted)

		MIN	MAX	UNIT
V_{OUT}	Channel off-state output pullup voltage		8	V
V_{COM}	COM pin voltage		8	V
$I_{OUT(ON)}$	Per channel continuous sink current	$V_{INx} = 3.3\text{ V}$	100 ⁽¹⁾	mA
		$V_{INx} = 5.0\text{ V}$	140 ⁽¹⁾	
T_J	Operating junction temperature	-40	125	$^{\circ}\text{C}$

(1) Refer to [Absolute Maximum Ratings](#) for T_J dependent absolute maximum GND-pin current

6.4 Thermal Information

THERMAL METRIC ⁽¹⁾		ULN2003LV		UNIT
		D (SOIC)	PW (TSSOP)	
		16 PINS	16 PINS	
$R_{\theta JA}$	Junction-to-ambient thermal resistance	112	142	$^{\circ}\text{C}/\text{W}$
$R_{\theta JC(top)}$	Junction-to-case (top) thermal resistance	69	74	$^{\circ}\text{C}/\text{W}$
$R_{\theta JB}$	Junction-to-board thermal resistance	69	87	$^{\circ}\text{C}/\text{W}$
ψ_{JT}	Junction-to-top characterization parameter	33	22	$^{\circ}\text{C}/\text{W}$
ψ_{JB}	Junction-to-board characterization parameter	69	87	$^{\circ}\text{C}/\text{W}$

(1) For more information about traditional and new thermal metrics, see the *Semiconductor and IC Package Thermal Metrics* application report, [SPRA953](#).

6.5 Electrical Characteristics

Specified over the recommended junction temperature range $T_J = -40^{\circ}\text{C}$ to 125°C unless otherwise noted. Typical values are at $T_J = 25^{\circ}\text{C}$.

PARAMETER		TEST CONDITIONS	MIN	TYP	MAX	UNIT
INPUTS IN1 THROUGH IN7 PARAMETERS						
$V_{I(ON)}$	IN1–IN7 logic high input voltage	$V_{pull-up} = 3.3\text{ V}$, $R_{pullup} = 1\text{ k}\Omega$, $I_{OUTX} = 3.2\text{ mA}$	1.65			V
$V_{I(OFF)}$	IN1–IN7 logic low input voltage	$V_{pullup} = 3.3\text{ V}$, $R_{pullup} = 1\text{ k}\Omega$, ($I_{OUTX} = <5\text{ }\mu\text{A}$)		0.4	0.6	V
$I_{I(ON)}$	IN1–IN7 ON state input current	$V_{pullup} = 3.3\text{ V}$, $V_{INx} = 3.3\text{ V}$		12	25	μA
$I_{I(OFF)}$	IN1–IN7 OFF state input leakage	$V_{pullup} = 3.3\text{ V}$, $V_{INx} = 0\text{ V}$			250	nA
OUTPUTS OUT1 THROUGH OUT7 PARAMETERS						
$V_{OL(VCE-SAT)}$	OUT1–OUT7 low-level output voltage	$V_{INX} = 3.3\text{ V}$, $I_{OUTX} = 50\text{ mA}$		0.17	0.24	V
		$V_{INX} = 3.3\text{ V}$, $I_{OUTX} = 100\text{ mA}$		0.36	0.49	
		$V_{INX} = 5.0\text{ V}$, $I_{OUTX} = 100\text{ mA}$		0.26	0.42	
		$V_{INX} = 5.0\text{ V}$, $I_{OUTX} = 140\text{ mA}$		0.40		
$I_{OUT(ON)}$	OUT1–OUT7 ON-state continuous current ^{(1) (2)} at $V_{OUTX} = 0.4\text{ V}$	$V_{INX} = 3.3\text{ V}$, $V_{OUTX} = 0.4\text{ V}$	80	100		mA
		$V_{INX} = 5.0\text{ V}$, $V_{OUTX} = 0.4\text{ V}$	95	140		
$I_{OUT(OFF)(ICEX)}$	OUT1–OUT7 OFF-state leakage current	$V_{INX} = 0\text{ V}$, $V_{OUTX} = V_{COM} = 8\text{ V}$		0.17		μA
FREE-WHEELING DIODE PARAMETERS⁽³⁾⁽⁴⁾						
VF	Forward voltage drop	$I_{F-peak} = 140\text{ mA}$, $V_F = V_{OUTx} - V_{COM}$		1.2		V
I_{F-peak}	Diode peak forward current			140		mA

- (1) The typical continuous current rating is limited by $V_{OL} = 0.4\text{ V}$. Whereas, absolute maximum operating continuous current may be limited by the Thermal Performance parameters listed in the Dissipation Rating Table and other Reliability parameters listed in the Recommended Operating Conditions Table.
- (2) Refer to the [Absolute Maximum Ratings](#) table for T_J dependent absolute maximum GND-pin current.
- (3) Not rated for continuous current operation – for higher reliability use an external freewheeling diode for inductive loads resulting in more than specified maximum free-wheeling diode peak current across various temperature conditions
- (4) Specified by design only.

6.6 Switching Characteristics

 over operating free-air temperature range (unless otherwise noted)⁽¹⁾⁽²⁾

PARAMETER		TEST CONDITIONS	MIN	TYP	MAX	UNIT
t _{PHL}	OUT1–OUT7 logic high propagation delay	V _{INX} = 3.3V, V _{pull-up} = 3.3 V, R _{pull-up} = 50 Ω		25		ns
		V _{INX} = 5.0V, V _{pull-up} = 5 V, R _{pull-up} = 1 kΩ		15		
t _{PLH}	OUT1–OUT7 logic low propagation delay	V _{INX} = 3.3V, V _{pull-up} = 3.3 V, R _{pull-up} = 50 Ω		45		ns
		V _{INX} = 5.0V, V _{pull-up} = 5 V, R _{pull-up} = 1kΩ		80		
R _{PD}	IN1–IN7 input pull-down Resistance		210	300	390	kΩ
ζ	IN1–IN7 Input filter time constant			9		ns
C _{OUT}	OUT1–OUT7 output capacitance	V _{INX} = 3.3 V, V _{OUTX} = 0.4 V		15		pF

- (1) Rise and Fall propagation delays, t_{PHL} and t_{PLH}, are measured between 50% values of the input and the corresponding output signal amplitude transition.
- (2) Specified by design only.

6.7 Dissipation Ratings

 See ⁽¹⁾⁽²⁾

BOARD	PACKAGE	R _{θJC}	R _{θJA} ⁽³⁾	DERATING FACTOR ABOVE T _A = 25°C	T _A < 25°C	T _A = 70°C	T _A = 85°C
High-K	16-Pin SOIC	69°C/W	112°C/W	8.88 mW/°C	1.11 W	0.71 W	0.58 W
High-K	16-Pin TSSOP	74°C/W	142°C/W	7.11 mW/°C	0.88 W	0.56 W	0.45 W

- (1) Maximum dissipation values for retaining device junction temperature of 150°C
- (2) Refer to TI's design support web page at www.ti.com/thermal for improving device thermal performance
- (3) Operating at the absolute T_{J,max} of 150°C can affect reliability– for higher reliability it is recommended to ensure T_J < 125°C

6.8 Typical Characteristics

T_A = +25°C

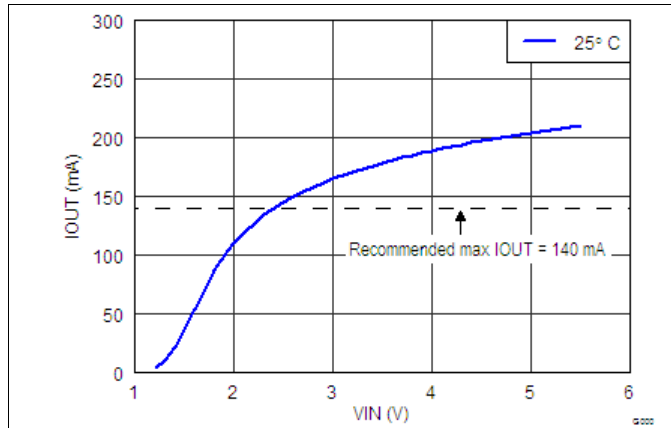

Figure 1. Load Current 1-Channel; VOL=0.4V

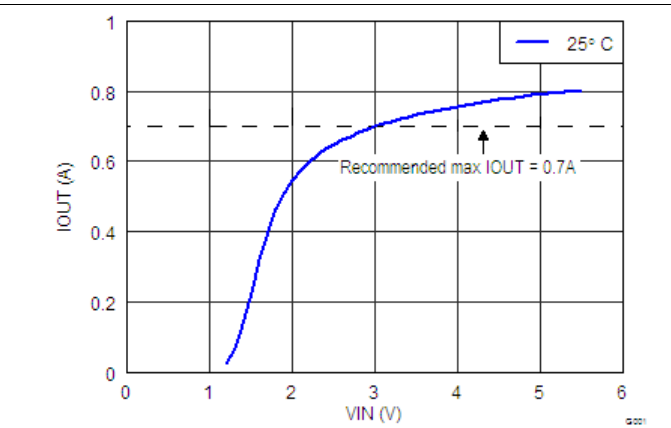

Figure 2. Load Current 7-Channels in Parallel; VOL=0.4V

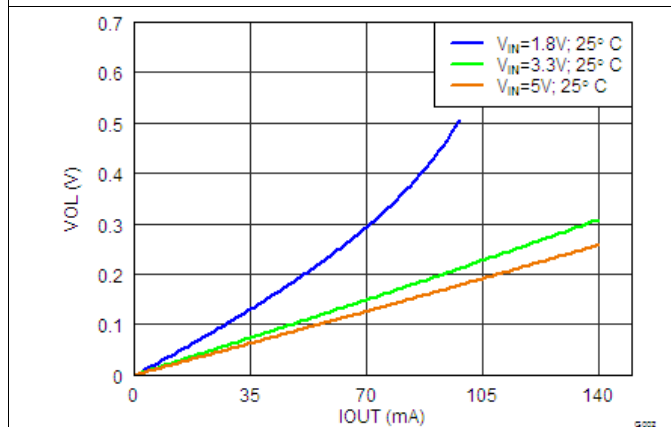

Figure 3. VOL versus IOUT VIN = 1.8V, 3.3V, 5.0V

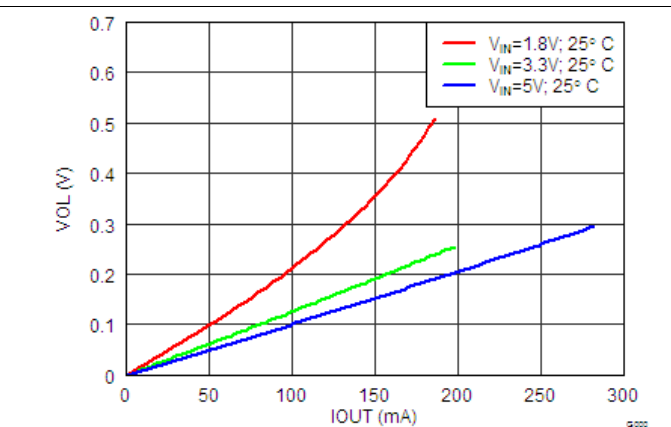

Figure 4. VOL versus IOUT 2-Channels in Parallel; VOL=0.4V

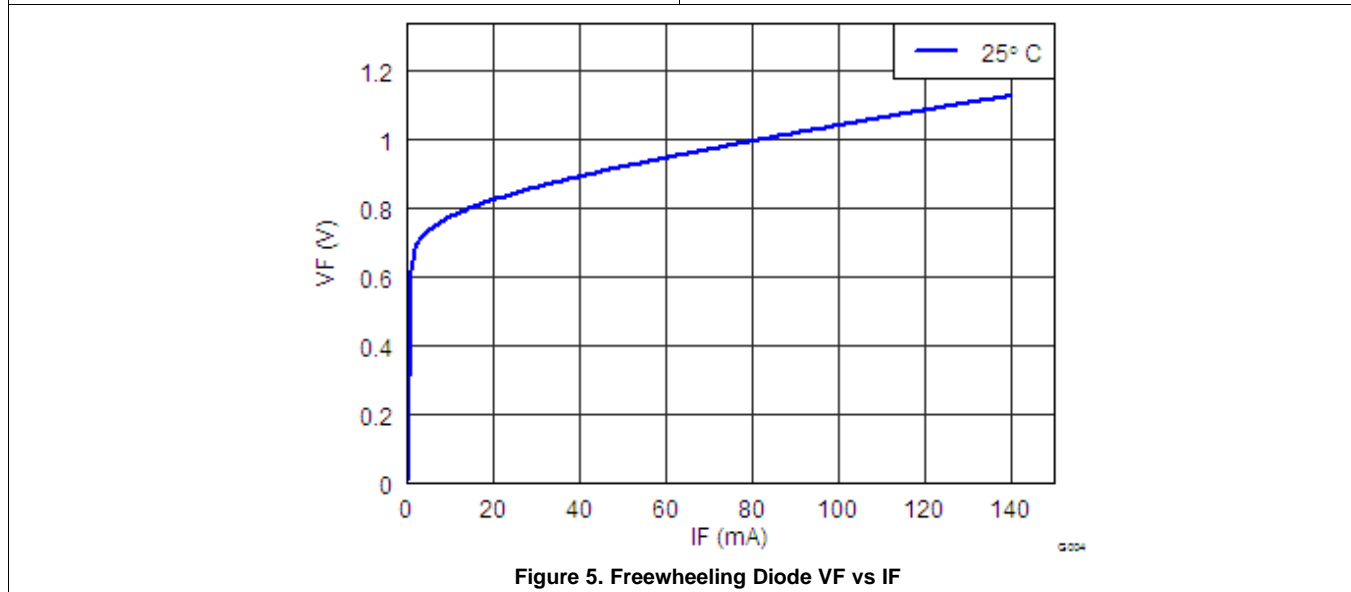

Figure 5. Freewheeling Diode VF vs IF

7 Detailed Description

7.1 Overview

ULN2003LV device is a seven-channel, low-side NMOS driver capable of driving 100-mA load with 3-V input drive voltage through each channel. This device can drive low voltage can drive low-voltage relays, LEDs or resistive loads. The ULN2003LV supports 3.3-V to 5-V CMOS logic input interface thus making it compatible to a wide range of micro-controllers and other logic interfaces. The ULN2003LV features an improved input interface that minimizes the input DC current drawn from the external drivers. The ULN2003LV features an input RC snubber that greatly improves its performance in noisy operating conditions. The ULN2003LV channel inputs feature an internal input pulldown resistor thus allowing input logic to be tri-stated. The ULN2003LV may also support other logic input levels, for example, TTL and 1.8 V.

7.2 Functional Block Diagram

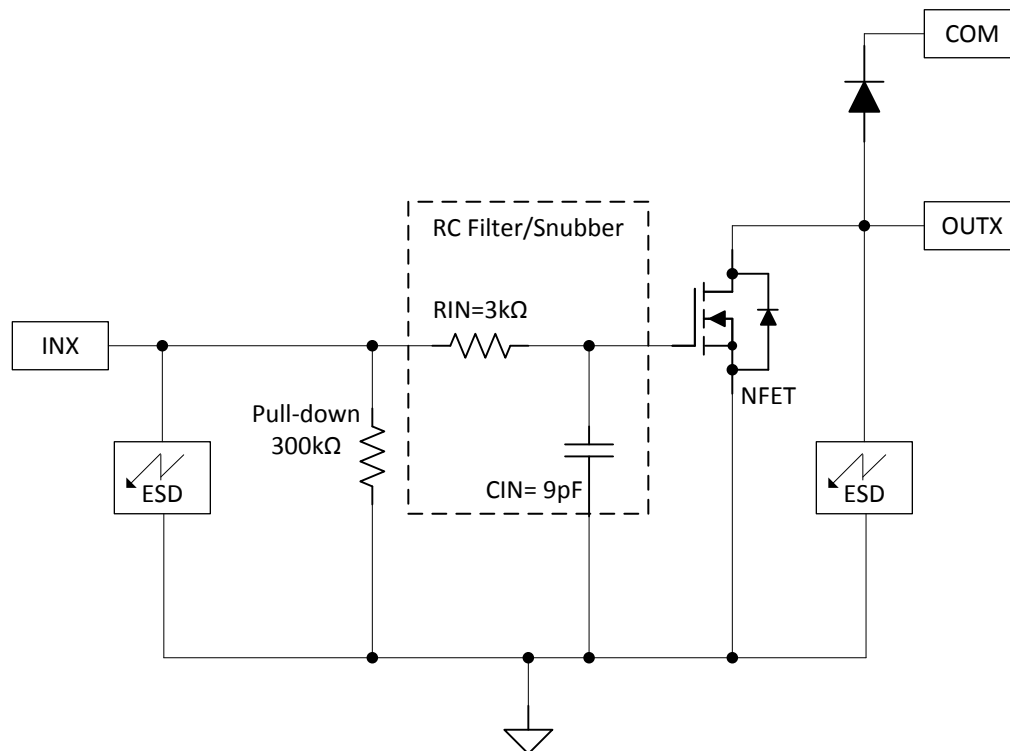

Figure 6. Channel Block Diagram

7.3 Feature Description

7.3.1 TTL and Other Logic Inputs

ULN2003LV input interface is specified for standard 3-V and 5-V CMOS logic interface. However, ULN2003LV input interface may support other logic input levels as well. Refer to [Figure 1](#) and [Figure 2](#) to establish VOL and the corresponding typical load current levels for various input voltage ranges. The [Application Information](#) section shows an implementation to drive 1.8-V relays using ULN2003LV.

7.3.2 Input RC Snubber

ULN2003LV features an input RC snubber that helps prevent spurious switching in noisy environment. Connect an external 1-kΩ to 5-kΩ resistor in series with the input to further enhance the noise tolerance of the ULN2003LV.

Feature Description (continued)

7.3.3 High-Impedance Input Drivers

ULN2003LV features a 300-k Ω input pulldown resistor. The presence of this resistor allows the input drivers to be tri-stated. When a high-impedance driver is connected to a channel input the ULN2003LV detects the channel input as a low-level input and remains in the OFF position. The input RC snubber helps improve noise tolerance when input drivers are in the high-impedance state.

7.4 Device Functional Modes

As shown in [Figure 6](#), each output of the ULN2003LV features an internal free-wheeling diode connected in a common-cathode configuration at the COM pin. The ULN2003LV provides flexibility of increasing current sink capability through combining several adjacent channels in parallel. Under typical conditions the ULN2003LV can support up to 1.0 A of load current when all 7-channels are connected in parallel. The ULN2003LV can also be used in a variety of other applications requiring a sink drivers.

Table 1. ULN2003LV Function Table⁽¹⁾

INPUT (IN1 – IN7)	OUTPUT (OUT1–OUT7)
L	Z
H	L
Z	Z

(1) L = Low-level (GND); H= High-level; Z= High-impedance

8 Application and Implementation

NOTE

Information in the following applications sections is not part of the TI component specification, and TI does not warrant its accuracy or completeness. TI's customers are responsible for determining suitability of components for their purposes. Customers should validate and test their design implementation to confirm system functionality.

8.1 Application Information

The typical application of the ULN2003LV is a sink driver. The ULN2003LV provides a low-impedance path to GND for driving external peripherals or open-drain signals. If all 7 channels are tied together, the ULN2003 can sink up to 1 A of current in these applications

8.2 Typical Application

To use ULN2003LV as an open-collector or an open-drain inverting logic level shifter configure the device as shown in [Figure 7](#). The ULN2003LV's each channel input and output logic levels can also be set independently. When using different channel input and output logic voltages connect the ULN2003LV COM pin to the maximum voltage.

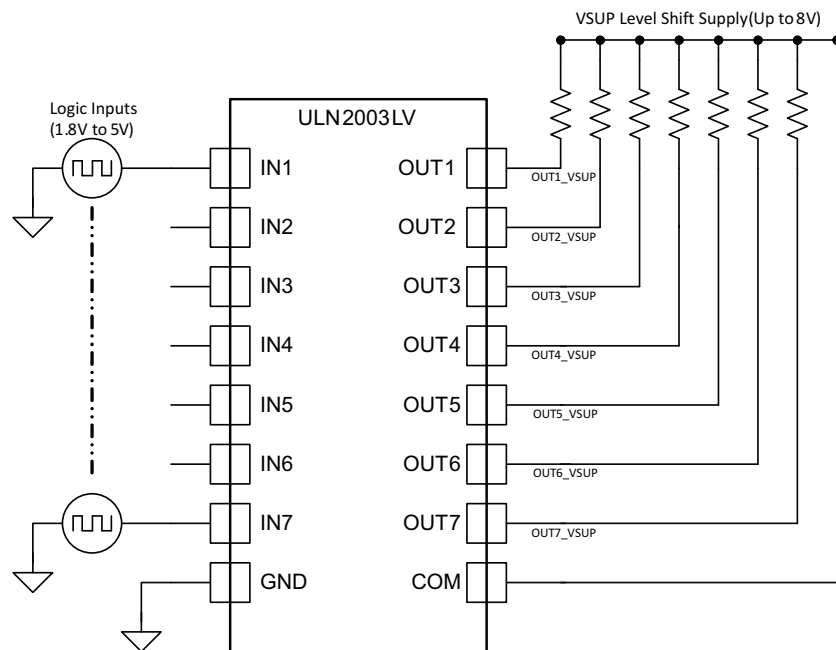

Figure 7. ULN2003LV as Inverting Logic Level Shifter

8.2.1 Design Requirements

ULN2003LV can be used in digital application requiring logic level shifting up to 8 V at the output side. Applications requiring a level shift operation from 1.8 V to 8 V. Since device pulls the output transistor low when input is high, this configuration is useful for applications requiring inverting logic with the level shifting operation.

8.2.2 Detailed Design Procedure

To operate in level shifting operation certain time aspects should be kept in mind. Depending on the pull up resistors at the output ULN2003LV exhibits different propagation delays. The choice of pull up resistor is dependent on the drive required at the output. The device can pull output to ground with the output transistor but to transition from low to high output resistor plays a critical role. If high drive at output is required a lower resistance can be calculated using [Equation 1](#).

$$R_{\text{Pullup}} = \text{OUT1_VSUP} / I_{\text{Drive}} \quad (1)$$

Typical Application (continued)

For example, a drive of 5 mA is required at the output for 1.8-V to 5-V translation application.

$$R_{\text{Pullup}} = \text{OUT1_VSUP} / I_{\text{Drive}} = 5/0.005 = 1 \text{ K} \tag{2}$$

8.2.3 Application Curve

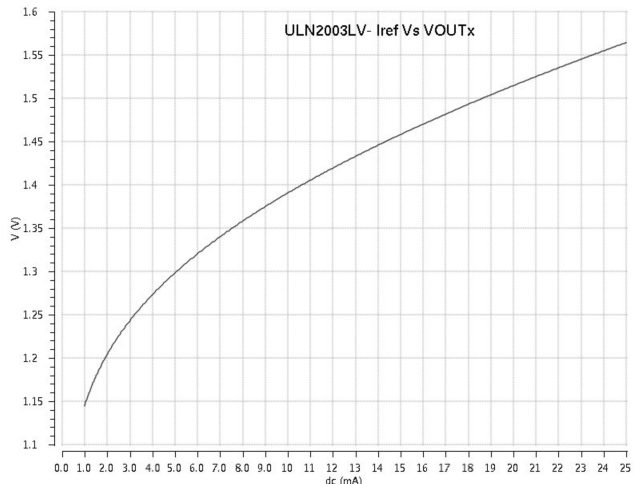

Figure 8. ULN2003LV Iref vs VOUTx

8.3 System Examples

8.3.1 Max Supply Selector

The [Figure 9](#) implements a max supply selector along with a 4-channel logic level shifter using a single ULN2003LV. This setup configures ULN2003LV's channel clamp diodes OUT5 – OUT7 in a diode-OR configuration and thus the maximum supply among VSUP1, VSUP2 and VSUP3 becomes available at the COM pin. The maximum supply is then used as a pull-up voltage for level shifters. Limit the net GND pin current to less than 100mA DC to ensure reliability of the conducting diode. The unconnected inputs IN5-IN7 are pulled to GND potential through 300kΩ internal pull-down resistor.

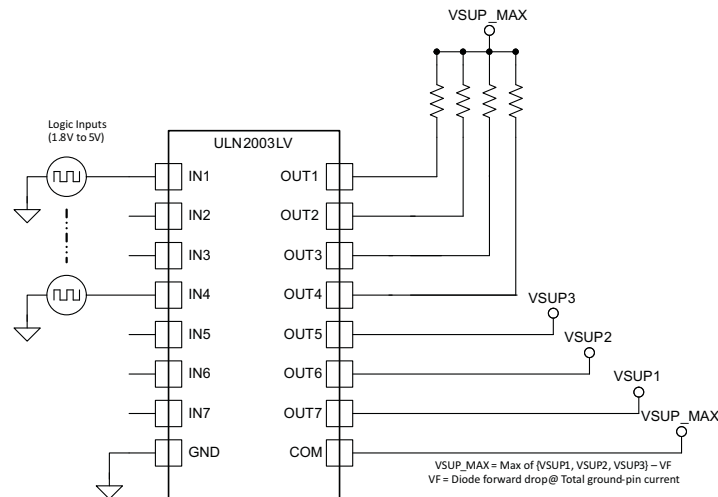

Figure 9. ULN2003LV as Max Supply Selector

System Examples (continued)

8.3.2 Constant Current Generation

When configured as per [Figure 10](#) the ULN2003LV outputs OUT1-OUT6 act as independent constant current sources. The current flowing through the resistor R1 is copied on all other channels. To increase the current sourcing connect several output channels in parallel. To ensure best current copying set voltage drop across connected load such that VOUTx matches to VOUT7.

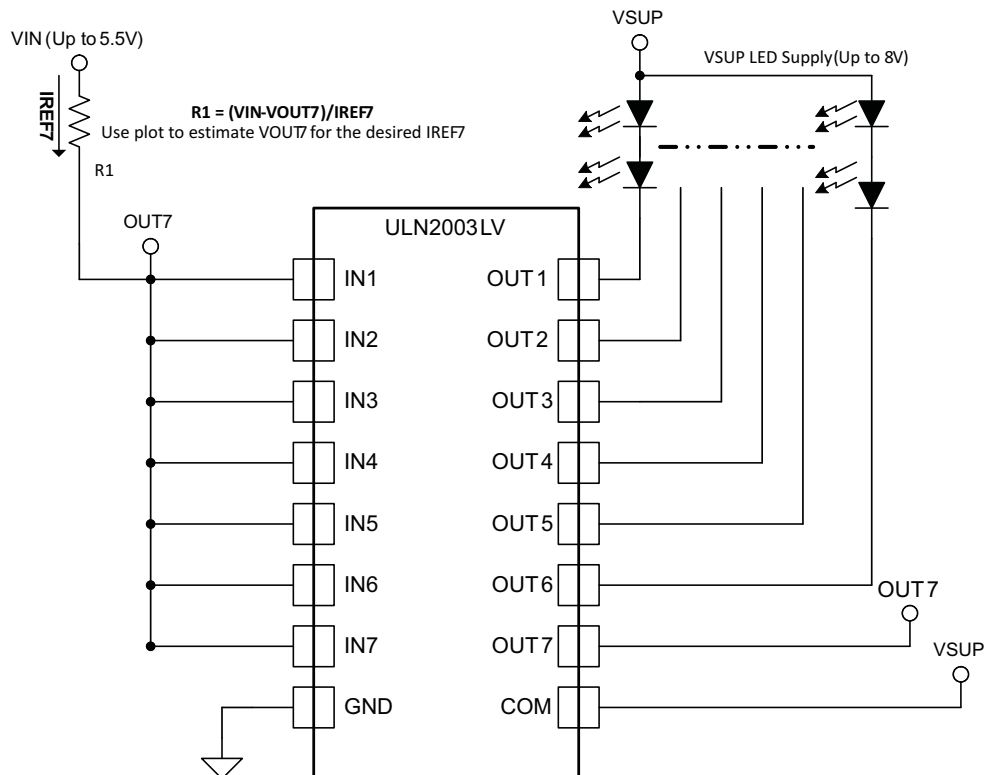

Figure 10. ULN2003LV as a Constant Current Driver

System Examples (continued)

8.3.3 Unipolar Stepper Motor Driver

The [Figure 11](#) shows an implementation of ULN2003LV for driving a unipolar stepper motor. The unconnected input channels can be used for other functions. When an input pin is left open the internal 300kΩ pull down resistor pulls the respective input pin to GND potential. For higher noise immunity use an external short across an unconnected input and GND pins.

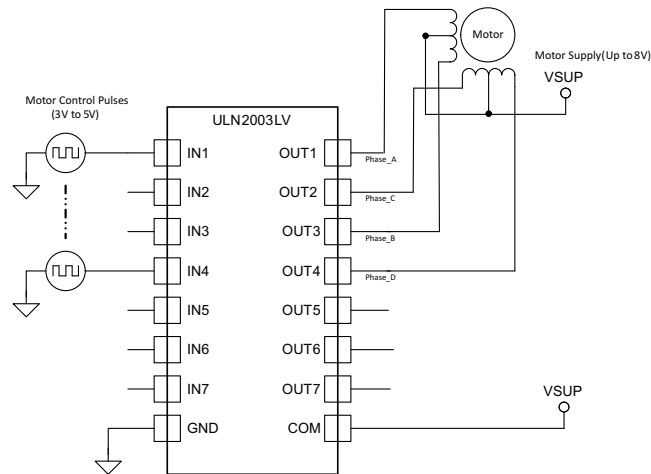

Figure 11. ULN2003LV as a Stepper Motor Driver

8.3.4 NOR Logic Driver

[Figure 12](#) shows a NOR Logic driver implementation using ULN2003LV. The output channels sharing a common pull-up resistor implement a logic NOR of the respective channel inputs. The LEDs connected to outputs OUT5-OUT7 light up when any of the inputs IN5-IN7 is logic-high ($> V_{IH}$).

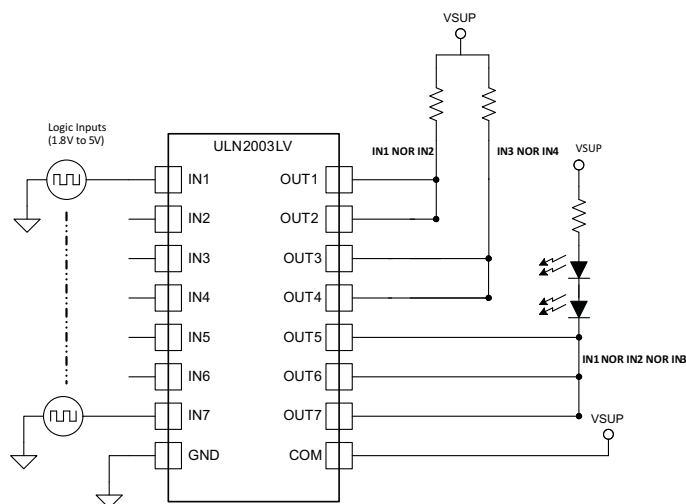

Figure 12. ULN2003LV as a NOR driver

System Examples (continued)

8.3.5 1.8-V Relay Driver

To drive lower voltage relays, like 1.8V, connect two or more adjacent channels in parallel as shown in Figure 13. Connecting several channels in parallel lowers the channel output resistance and thus minimizes VOL for a fixed current.

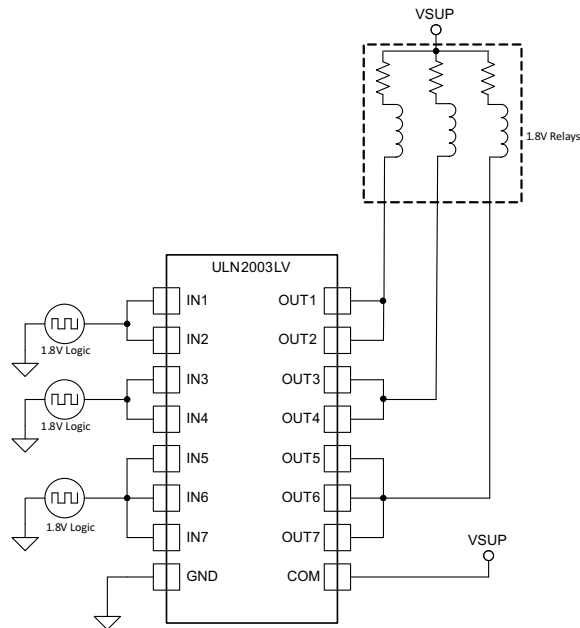

Figure 13. ULN2003LV Driving 1.8V Relays

9 Power Supply Recommendations

The COM pin is the power supply pin of this device to power the gate drive circuitry. Although not required but depending on the power supply, TI recommends to put a bypass capacitor of 100 nF across the Vcom pin and Gnd.

10 Layout

10.1 Layout Guidelines

Thin traces can be used on the input due to the low current logic that is typically used to drive ULN2003LV. Take care to separate the input channels as much as possible, as to eliminate cross-talk. Thick traces are recommended for the output, in order to drive high currents that may be needed. Wire thickness can be determined by the trace material's current density and desired drive current. Since all of the channels currents return to a common ground, it is best to size that trace width to be very wide. Some applications require up to 1 A.

10.2 Layout Example

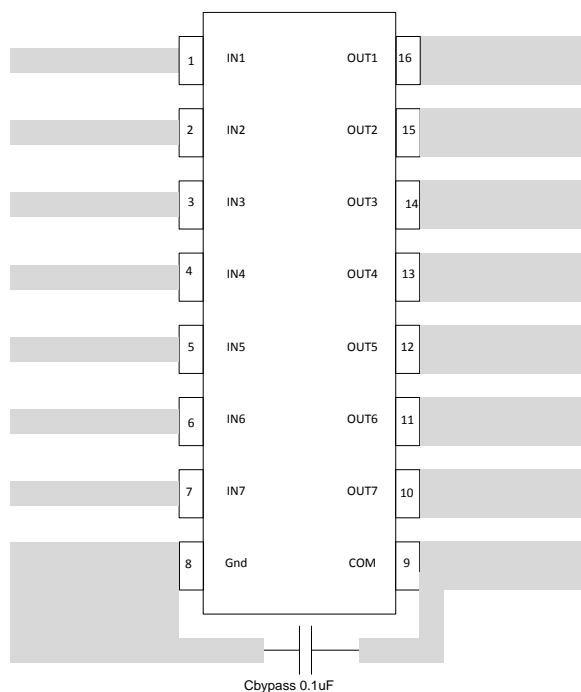

Figure 14. Layout Example Recommendation

10.3 On-Chip Power Dissipation

Use [Equation 3](#) to calculate ULN2003LV on-chip power dissipation P_D :

$$P_D = \sum_{i=1}^N V_{OLi} \times I_{Li}$$

where

- N is the number of channels active together.
- V_{OLi} is the OUT_i pin voltage for the load current I_{Li} .

(3)

10.4 Thermal Considerations

TI recommends to limit ULN2003LV IC's die junction temperature to less than 125°C. The IC junction temperature is directly proportional to the on-chip power dissipation. Use the following equation to calculate the maximum allowable on-chip power dissipation for a target IC junction temperature:

$$PD_{(MAX)} = \frac{(T_{J(MAX)} - T_A)}{\theta_{JA}}$$

where

- $T_{J(MAX)}$ is the target maximum junction temperature.
- T_A is the operating ambient temperature.
- $R_{\theta JA}$ is the package junction to ambient thermal resistance. (4)

10.4.1 Improving Package Thermal Performance

The package $R_{\theta JA}$ value under standard conditions on a High-K board is listed in the [Dissipation Ratings](#). $R_{\theta JA}$ value depends on the PCB layout. An external heat sink and/or a cooling mechanism, like a cold air fan, can help reduce $R_{\theta JA}$ and thus improve device thermal capabilities. Refer to TI's design support web page at www.ti.com/thermal for a general guidance on improving device thermal performance.

11 Device and Documentation Support

11.1 Community Resources

The following links connect to TI community resources. Linked contents are provided "AS IS" by the respective contributors. They do not constitute TI specifications and do not necessarily reflect TI's views; see TI's [Terms of Use](#).

TI E2E™ Online Community *TI's Engineer-to-Engineer (E2E) Community*. Created to foster collaboration among engineers. At e2e.ti.com, you can ask questions, share knowledge, explore ideas and help solve problems with fellow engineers.

Design Support *TI's Design Support* Quickly find helpful E2E forums along with design support tools and contact information for technical support.

11.2 Trademarks

E2E is a trademark of Texas Instruments.
All other trademarks are the property of their respective owners.

11.3 Electrostatic Discharge Caution



These devices have limited built-in ESD protection. The leads should be shorted together or the device placed in conductive foam during storage or handling to prevent electrostatic damage to the MOS gates.

11.4 Glossary

[SLYZ022](#) — *TI Glossary*.

This glossary lists and explains terms, acronyms, and definitions.

12 Mechanical, Packaging, and Orderable Information

The following pages include mechanical, packaging, and orderable information. This information is the most current data available for the designated devices. This data is subject to change without notice and revision of this document. For browser-based versions of this data sheet, refer to the left-hand navigation.

PACKAGING INFORMATION

Orderable Device	Status (1)	Package Type	Package Drawing	Pins	Package Qty	Eco Plan (2)	Lead/Ball Finish (6)	MSL Peak Temp (3)	Op Temp (°C)	Device Marking (4/5)	Samples
ULN2003LVDR	ACTIVE	SOIC	D	16	2500	Green (RoHS & no Sb/Br)	CU SN	Level-1-260C-UNLIM	-40 to 85	UN2003LV	Samples
ULN2003LVPWR	ACTIVE	TSSOP	PW	16	2000	Green (RoHS & no Sb/Br)	CU SN	Level-1-260C-UNLIM	-40 to 85	UN2003LV	Samples

(1) The marketing status values are defined as follows:

ACTIVE: Product device recommended for new designs.

LIFEBUY: TI has announced that the device will be discontinued, and a lifetime-buy period is in effect.

NRND: Not recommended for new designs. Device is in production to support existing customers, but TI does not recommend using this part in a new design.

PREVIEW: Device has been announced but is not in production. Samples may or may not be available.

OBSOLETE: TI has discontinued the production of the device.

(2) Eco Plan - The planned eco-friendly classification: Pb-Free (RoHS), Pb-Free (RoHS Exempt), or Green (RoHS & no Sb/Br) - please check <http://www.ti.com/productcontent> for the latest availability information and additional product content details.

TBD: The Pb-Free/Green conversion plan has not been defined.

Pb-Free (RoHS): TI's terms "Lead-Free" or "Pb-Free" mean semiconductor products that are compatible with the current RoHS requirements for all 6 substances, including the requirement that lead not exceed 0.1% by weight in homogeneous materials. Where designed to be soldered at high temperatures, TI Pb-Free products are suitable for use in specified lead-free processes.

Pb-Free (RoHS Exempt): This component has a RoHS exemption for either 1) lead-based flip-chip solder bumps used between the die and package, or 2) lead-based die adhesive used between the die and leadframe. The component is otherwise considered Pb-Free (RoHS compatible) as defined above.

Green (RoHS & no Sb/Br): TI defines "Green" to mean Pb-Free (RoHS compatible), and free of Bromine (Br) and Antimony (Sb) based flame retardants (Br or Sb do not exceed 0.1% by weight in homogeneous material)

(3) MSL, Peak Temp. - The Moisture Sensitivity Level rating according to the JEDEC industry standard classifications, and peak solder temperature.

(4) There may be additional marking, which relates to the logo, the lot trace code information, or the environmental category on the device.

(5) Multiple Device Markings will be inside parentheses. Only one Device Marking contained in parentheses and separated by a "~" will appear on a device. If a line is indented then it is a continuation of the previous line and the two combined represent the entire Device Marking for that device.

(6) Lead/Ball Finish - Orderable Devices may have multiple material finish options. Finish options are separated by a vertical ruled line. Lead/Ball Finish values may wrap to two lines if the finish value exceeds the maximum column width.

Important Information and Disclaimer: The information provided on this page represents TI's knowledge and belief as of the date that it is provided. TI bases its knowledge and belief on information provided by third parties, and makes no representation or warranty as to the accuracy of such information. Efforts are underway to better integrate information from third parties. TI has taken and continues to take reasonable steps to provide representative and accurate information but may not have conducted destructive testing or chemical analysis on incoming materials and chemicals. TI and TI suppliers consider certain information to be proprietary, and thus CAS numbers and other limited information may not be available for release.

In no event shall TI's liability arising out of such information exceed the total purchase price of the TI part(s) at issue in this document sold by TI to Customer on an annual basis.

TAPE AND REEL INFORMATION



QUADRANT ASSIGNMENTS FOR PIN 1 ORIENTATION IN TAPE



*All dimensions are nominal

Device	Package Type	Package Drawing	Pins	SPQ	Reel Diameter (mm)	Reel Width W1 (mm)	A0 (mm)	B0 (mm)	K0 (mm)	P1 (mm)	W (mm)	Pin1 Quadrant
ULN2003LVDR	SOIC	D	16	2500	330.0	16.8	6.5	10.3	2.1	8.0	16.0	Q1
ULN2003LVPWR	TSSOP	PW	16	2000	330.0	12.4	6.9	5.6	1.6	8.0	12.0	Q1

TAPE AND REEL BOX DIMENSIONS

*All dimensions are nominal

Device	Package Type	Package Drawing	Pins	SPQ	Length (mm)	Width (mm)	Height (mm)
ULN2003LVDR	SOIC	D	16	2500	364.0	364.0	27.0
ULN2003LVPWR	TSSOP	PW	16	2000	364.0	364.0	27.0

D (R-PDSO-G16)

PLASTIC SMALL OUTLINE



- NOTES:
- A. All linear dimensions are in inches (millimeters).
 - B. This drawing is subject to change without notice.
 - C. Body length does not include mold flash, protrusions, or gate burrs. Mold flash, protrusions, or gate burrs shall not exceed 0.006 (0,15) each side.
 - D. Body width does not include interlead flash. Interlead flash shall not exceed 0.017 (0,43) each side.
 - E. Reference JEDEC MS-012 variation AC.

D (R-PDSO-G16)

PLASTIC SMALL OUTLINE



- NOTES:
- All linear dimensions are in millimeters.
 - This drawing is subject to change without notice.
 - Publication IPC-7351 is recommended for alternate designs.
 - Laser cutting apertures with trapezoidal walls and also rounding corners will offer better paste release. Customers should contact their board assembly site for stencil design recommendations. Refer to IPC-7525 for other stencil recommendations.
 - Customers should contact their board fabrication site for solder mask tolerances between and around signal pads.



4220204/A 02/2017

NOTES:

1. All linear dimensions are in millimeters. Any dimensions in parenthesis are for reference only. Dimensioning and tolerancing per ASME Y14.5M.
2. This drawing is subject to change without notice.
3. This dimension does not include mold flash, protrusions, or gate burrs. Mold flash, protrusions, or gate burrs shall not exceed 0.15 mm per side.
4. This dimension does not include interlead flash. Interlead flash shall not exceed 0.25 mm per side.
5. Reference JEDEC registration MO-153.

EXAMPLE BOARD LAYOUT

PW0016A

TSSOP - 1.2 mm max height

SMALL OUTLINE PACKAGE



LAND PATTERN EXAMPLE
EXPOSED METAL SHOWN
SCALE: 10X



4220204/A 02/2017

NOTES: (continued)

- 6. Publication IPC-7351 may have alternate designs.
- 7. Solder mask tolerances between and around signal pads can vary based on board fabrication site.

EXAMPLE STENCIL DESIGN

PW0016A

TSSOP - 1.2 mm max height

SMALL OUTLINE PACKAGE

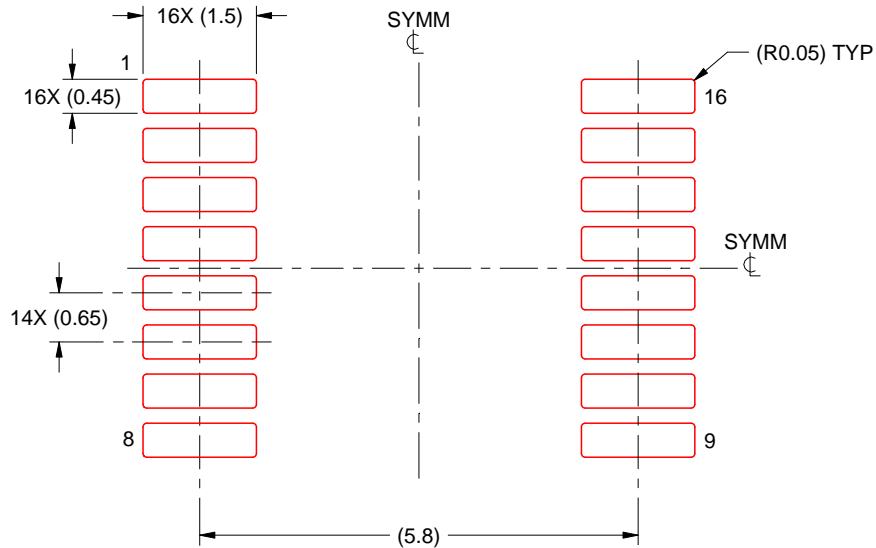

SOLDER PASTE EXAMPLE
BASED ON 0.125 mm THICK STENCIL
SCALE: 10X

4220204/A 02/2017

NOTES: (continued)

8. Laser cutting apertures with trapezoidal walls and rounded corners may offer better paste release. IPC-7525 may have alternate design recommendations.
9. Board assembly site may have different recommendations for stencil design.

IMPORTANT NOTICE AND DISCLAIMER

TI PROVIDES TECHNICAL AND RELIABILITY DATA (INCLUDING DATASHEETS), DESIGN RESOURCES (INCLUDING REFERENCE DESIGNS), APPLICATION OR OTHER DESIGN ADVICE, WEB TOOLS, SAFETY INFORMATION, AND OTHER RESOURCES "AS IS" AND WITH ALL FAULTS, AND DISCLAIMS ALL WARRANTIES, EXPRESS AND IMPLIED, INCLUDING WITHOUT LIMITATION ANY IMPLIED WARRANTIES OF MERCHANTABILITY, FITNESS FOR A PARTICULAR PURPOSE OR NON-INFRINGEMENT OF THIRD PARTY INTELLECTUAL PROPERTY RIGHTS.

These resources are intended for skilled developers designing with TI products. You are solely responsible for (1) selecting the appropriate TI products for your application, (2) designing, validating and testing your application, and (3) ensuring your application meets applicable standards, and any other safety, security, or other requirements. These resources are subject to change without notice. TI grants you permission to use these resources only for development of an application that uses the TI products described in the resource. Other reproduction and display of these resources is prohibited. No license is granted to any other TI intellectual property right or to any third party intellectual property right. TI disclaims responsibility for, and you will fully indemnify TI and its representatives against, any claims, damages, costs, losses, and liabilities arising out of your use of these resources.

TI's products are provided subject to TI's Terms of Sale (www.ti.com/legal/termsofsale.html) or other applicable terms available either on ti.com or provided in conjunction with such TI products. TI's provision of these resources does not expand or otherwise alter TI's applicable warranties or warranty disclaimers for TI products.

Mailing Address: Texas Instruments, Post Office Box 655303, Dallas, Texas 75265
Copyright © 2018, Texas Instruments Incorporated

Looking for pricing, stock, or lifecycle information?

Click below to explore more details on WIN SOURCE:

 [View ULN2003LVDR on WIN SOURCE](#)

 [Texas Instruments](#) Information

Optimize Your Supply Chain with WIN SOURCE Solutions

-  Global Sourcing Solution
-  Obsolete Management
-  Cost Control Management
-  Shortage Management
-  Alternative Solution
-  Excess Inventory Management