



# THE DATASHEET OF ULN2003AD



## ULN200x, ULQ200x High-Voltage, High-Current Darlington Transistor Arrays

### 1 Features

- 500-mA-Rated Collector Current (Single Output)
- High-Voltage Outputs: 50 V
- Output Clamp Diodes
- Inputs Compatible With Various Types of Logic
- Relay-Driver Applications

### 2 Applications

- Relay Drivers
- Stepper and DC Brushed Motor Drivers
- Lamp Drivers
- Display Drivers (LED and Gas Discharge)
- Line Drivers
- Logic Buffers

### 3 Description

The ULx200xA devices are high-voltage, high-current Darlington transistor arrays. Each consists of seven NPN Darlington pairs that feature high-voltage outputs with common-cathode clamp diodes for switching inductive loads.

The collector-current rating of a single Darlington pair is 500 mA. The Darlington pairs can be paralleled for higher current capability. Applications include relay drivers, hammer drivers, lamp drivers, display drivers (LED and gas discharge), line drivers, and logic buffers. For 100-V (otherwise interchangeable) versions of the ULx2003A devices, see the [SLRS023](#) data sheet for the SN75468 and SN75469 devices.

The ULN2002A device is designed specifically for use with 14-V to 25-V PMOS devices. Each input of this device has a Zener diode and resistor in series to control the input current to a safe limit. The ULx2003A devices have a 2.7-k $\Omega$  series base resistor for each Darlington pair for operation directly with TTL or 5-V CMOS devices.

The ULx2004A devices have a 10.5-k $\Omega$  series base resistor to allow operation directly from CMOS devices that use supply voltages of 6 V to 15 V. The required input current of the ULx2004A device is below that of the ULx2003A devices, and the required voltage is less than that required by the ULN2002A device.

Device Information<sup>(1)</sup>

PART NUMBER	PACKAGE	BODY SIZE (NOM)
ULx200xD	SOIC (16)	9.90 mm x 3.91 mm
ULx200xN	PDIP (16)	19.30 mm x 6.35 mm
ULN200xNS	SOP (16)	10.30 mm x 5.30 mm
ULN200xPW	TSSOP (16)	5.00 mm x 4.40 mm

(1) For all available packages, see the orderable addendum at the end of the data sheet.

Simplified Block Diagram



## Table of Contents

<b>1 Features</b> .....	<b>1</b>	<b>7 Parameter Measurement Information</b> .....	<b>10</b>
<b>2 Applications</b> .....	<b>1</b>	<b>8 Detailed Description</b> .....	<b>12</b>
<b>3 Description</b> .....	<b>1</b>	8.1 Overview .....	12
<b>4 Revision History</b> .....	<b>2</b>	8.2 Functional Block Diagrams .....	12
<b>5 Pin Configuration and Functions</b> .....	<b>3</b>	8.3 Feature Description .....	13
<b>6 Specifications</b> .....	<b>4</b>	8.4 Device Functional Modes .....	13
6.1 Absolute Maximum Ratings .....	4	<b>9 Application and Implementation</b> .....	<b>14</b>
6.2 ESD Ratings .....	4	9.1 Application Information .....	14
6.3 Recommended Operating Conditions .....	4	9.2 Typical Application .....	14
6.4 Thermal Information .....	4	9.3 System Examples .....	17
6.5 Electrical Characteristics: ULN2002A .....	5	<b>10 Power Supply Recommendations</b> .....	<b>18</b>
6.6 Electrical Characteristics: ULN2003A and ULN2004A .....	5	<b>11 Layout</b> .....	<b>18</b>
6.7 Electrical Characteristics: ULN2003AI .....	6	11.1 Layout Guidelines .....	18
6.8 Electrical Characteristics: ULN2003AI .....	6	11.2 Layout Example .....	18
6.9 Electrical Characteristics: ULQ2003A and ULQ2004A .....	7	<b>12 Device and Documentation Support</b> .....	<b>19</b>
6.10 Switching Characteristics: ULN2002A, ULN2003A, ULN2004A .....	7	12.1 Documentation Support .....	19
6.11 Switching Characteristics: ULN2003AI .....	7	12.2 Related Links .....	19
6.12 Switching Characteristics: ULN2003AI .....	8	12.3 Community Resources .....	19
6.13 Switching Characteristics: ULQ2003A, ULQ2004A .....	8	12.4 Trademarks .....	19
6.14 Typical Characteristics .....	8	12.5 Electrostatic Discharge Caution .....	19
		12.6 Glossary .....	19
		<b>13 Mechanical, Packaging, and Orderable Information</b> .....	<b>19</b>

## 4 Revision History

NOTE: Page numbers for previous revisions may differ from page numbers in the current version.

<b>Changes from Revision N (June 2015) to Revision O</b> .....	<b>Page</b>
• Changed Pin Functions table to correct typographical error. ....	<b>3</b>
<b>Changes from Revision M (February 2013) to Revision N</b> .....	<b>Page</b>
• Added <i>Pin Configuration and Functions</i> section, <i>ESD Ratings</i> table, <i>Feature Description</i> section, <i>Device Functional Modes</i> , <i>Application and Implementation</i> section, <i>Power Supply Recommendations</i> section, <i>Layout</i> section, <i>Device and Documentation Support</i> section, and <i>Mechanical, Packaging, and Orderable Information</i> section .....	<b>1</b>
• Deleted <i>Ordering Information</i> table. No specification changes. ....	<b>1</b>
• Moved <i>Typical Characteristics</i> into <i>Specifications</i> section. ....	<b>8</b>
<b>Changes from Revision L (April 2012) to Revision M</b> .....	<b>Page</b>
• Updated temperature rating for ULN2003AI in the ORDERING INFORMATION table .....	<b>1</b>
<b>Changes from Revision K (August 2011) to Revision L</b> .....	<b>Page</b>
• Removed reference to obsolete ULN2001 device .....	<b>1</b>

## 5 Pin Configuration and Functions

**D, N, NS, and PW Package  
16-Pin SOIC, PDIP, SO, and TSSOP  
Top View**

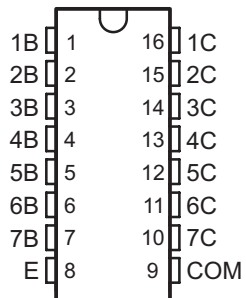

**Pin Functions**

PIN		I/O <sup>(1)</sup>	DESCRIPTION
NAME	NO.		
1B	1	I	Channel 1 through 7 Darlington base input
2B	2		
3B	3		
4B	4		
5B	5		
6B	6		
7B	7		
1C	16	O	Channel 1 through 7 Darlington collector output
2C	15		
3C	14		
4C	13		
5C	12		
6C	11		
7C	10		
COM	9	—	Common cathode node for flyback diodes (required for inductive loads)
E	8	—	Common emitter shared by all channels (typically tied to ground)

(1) I = Input, O = Output

## 6 Specifications

### 6.1 Absolute Maximum Ratings

at 25°C free-air temperature (unless otherwise noted)<sup>(1)</sup>

		MIN	MAX	UNIT	
V <sub>CC</sub>	Collector-emitter voltage		50	V	
	Clamp diode reverse voltage <sup>(2)</sup>		50	V	
V <sub>I</sub>	Input voltage <sup>(2)</sup>		30	V	
	Peak collector current, See <a href="#">Figure 4</a> and <a href="#">Figure 5</a>		500	mA	
I <sub>OK</sub>	Output clamp current		500	mA	
	Total emitter-terminal current		-2.5	A	
T <sub>A</sub>	Operating free-air temperature range	ULN200xA	-20	70	°C
		ULN200xAI	-40	105	
		ULQ200xA	-40	85	
		ULQ200xAT	-40	105	
T <sub>J</sub>	Operating virtual junction temperature		150	°C	
	Lead temperature for 1.6 mm (1/16 inch) from case for 10 seconds		260	°C	
T <sub>stg</sub>	Storage temperature	-65	150	°C	

- (1) Stresses beyond those listed under *Absolute Maximum Ratings* may cause permanent damage to the device. These are stress ratings only, and functional operation of the device at these or any other conditions beyond those indicated under *Recommended Operating Conditions* is not implied. Exposure to absolute-maximum-rated conditions for extended periods may affect device reliability.
- (2) All voltage values are with respect to the emitter/substrate terminal E, unless otherwise noted.

### 6.2 ESD Ratings

			VALUE	UNIT
V <sub>(ESD)</sub>	Electrostatic discharge	Human body model (HBM), per ANSI/ESDA/JEDEC JS-001 <sup>(1)</sup>	±2000	V
		Charged device model (CDM), per JEDEC specification JESD22-C101 <sup>(2)</sup>	±500	

- (1) JEDEC document JEP155 states that 500-V HBM allows safe manufacturing with a standard ESD control process.
- (2) JEDEC document JEP157 states that 250-V CDM allows safe manufacturing with a standard ESD control process.

### 6.3 Recommended Operating Conditions

over operating free-air temperature range (unless otherwise noted)

		MIN	MAX	UNIT
V <sub>CC</sub>	Collector-emitter voltage (non-V devices)	0	50	V
T <sub>J</sub>	Junction temperature	-40	125	°C

### 6.4 Thermal Information

THERMAL METRIC <sup>(1)</sup>		ULx200x				UNIT
		D (SOIC)	N (PDIP)	NS (SO)	PW (TSSOP)	
		16 PINS	16 PINS	16 PINS	16 PINS	
R <sub>θJA</sub>	Junction-to-ambient thermal resistance	73	67	64	108	°C/W
R <sub>θJC(top)</sub>	Junction-to-case (top) thermal resistance	36	54	n/a	33.6	°C/W
R <sub>θJB</sub>	Junction-to-board thermal resistance	n/a	n/a	n/a	51.9	°C/W
ψ <sub>JT</sub>	Junction-to-top characterization parameter	n/a	n/a	n/a	2.1	°C/W
ψ <sub>JB</sub>	Junction-to-board characterization parameter	n/a	n/a	n/a	51.4	°C/W

- (1) For more information about traditional and new thermal metrics, see the *Semiconductor and IC Package Thermal Metrics* application report, [SPRA953](#).

## 6.5 Electrical Characteristics: ULN2002A

 $T_A = 25^\circ\text{C}$ 

PARAMETER	TEST FIGURE	TEST CONDITIONS	ULN2002A			UNIT
			MIN	TYP	MAX	
$V_{I(on)}$ ON-state input voltage	Figure 14	$V_{CE} = 2\text{ V}$ , $I_C = 300\text{ mA}$			13	V
$V_{OH}$ High-level output voltage after switching	Figure 18	$V_S = 50\text{ V}$ , $I_O = 300\text{ mA}$	$V_S - 20$			mV
$V_{CE(sat)}$ Collector-emitter saturation voltage	Figure 12	$I_I = 250\ \mu\text{A}$ , $I_C = 100\text{ mA}$		0.9	1.1	V
		$I_I = 350\ \mu\text{A}$ , $I_C = 200\text{ mA}$		1	1.3	
		$I_I = 500\ \mu\text{A}$ , $I_C = 350\text{ mA}$		1.2	1.6	
$V_F$ Clamp forward voltage	Figure 15	$I_F = 350\text{ mA}$		1.7	2	V
$I_{CEX}$ Collector cutoff current	Figure 9	$V_{CE} = 50\text{ V}$ , $I_I = 0$			50	$\mu\text{A}$
	Figure 10	$V_{CE} = 50\text{ V}$ , $T_A = 70^\circ\text{C}$ , $V_I = 6\text{ V}$			100 500	
$I_{I(off)}$ OFF-state input current	Figure 10	$V_{CE} = 50\text{ V}$ , $I_C = 500\ \mu\text{A}$	50	65		$\mu\text{A}$
$I_I$ Input current	Figure 11	$V_I = 17\text{ V}$		0.82	1.25	mA
$I_R$ Clamp reverse current	Figure 14	$V_R = 50\text{ V}$ , $T_A = 70^\circ\text{C}$			100	$\mu\text{A}$
		$V_R = 50\text{ V}$			50	
$C_i$ Input capacitance		$V_I = 0$ , $f = 1\text{ MHz}$			25	pF

## 6.6 Electrical Characteristics: ULN2003A and ULN2004A

 $T_A = 25^\circ\text{C}$ 

PARAMETER	TEST FIGURE	TEST CONDITIONS	ULN2003A			ULN2004A			UNIT							
			MIN	TYP	MAX	MIN	TYP	MAX								
$V_{I(on)}$ ON-state input voltage	Figure 14	$V_{CE} = 2\text{ V}$							5							
									$I_C = 125\text{ mA}$							6
									$I_C = 200\text{ mA}$		2.4					
									$I_C = 250\text{ mA}$		2.7					
									$I_C = 275\text{ mA}$							7
									$I_C = 300\text{ mA}$		3					
$V_{OH}$ High-level output voltage after switching	Figure 18	$V_S = 50\text{ V}$ , $I_O = 300\text{ mA}$							mV							
										$V_S - 20$						
										$V_S - 20$						
$V_{CE(sat)}$ Collector-emitter saturation voltage	Figure 13								0.9							
									$I_I = 250\ \mu\text{A}$ , $I_C = 100\text{ mA}$		0.9	1.1		0.9	1.1	
									$I_I = 350\ \mu\text{A}$ , $I_C = 200\text{ mA}$		1	1.3		1	1.3	
$V_{CE(sat)}$ Collector-emitter saturation voltage	Figure 13								1.2							
									$I_I = 500\ \mu\text{A}$ , $I_C = 350\text{ mA}$		1.2	1.6		1.2	1.6	
$I_{CEX}$ Collector cutoff current	Figure 9	$V_{CE} = 50\text{ V}$ , $I_I = 0$			50			50	$\mu\text{A}$							
	Figure 10	$V_{CE} = 50\text{ V}$ , $T_A = 70^\circ\text{C}$ , $V_I = 6\text{ V}$			100			100 500								
$V_F$ Clamp forward voltage	Figure 16	$I_F = 350\text{ mA}$		1.7	2			1.7	2	V						
$I_{I(off)}$ Off-state input current	Figure 11	$V_{CE} = 50\text{ V}$ , $T_A = 70^\circ\text{C}$ , $I_C = 500\ \mu\text{A}$	50	65		50	65			$\mu\text{A}$						
$I_I$ Input current	Figure 12									0.93						
										$V_I = 3.85\text{ V}$		1.35				
										$V_I = 5\text{ V}$				0.35	0.5	
$I_I$ Input current	Figure 12									1						
										$V_I = 12\text{ V}$				1	1.45	
$I_R$ Clamp reverse current	Figure 15	$V_R = 50\text{ V}$ , $T_A = 70^\circ\text{C}$								50						
										$V_R = 50\text{ V}$		100			100	
$C_i$ Input capacitance		$V_I = 0$ , $f = 1\text{ MHz}$		15	25			15	25	pF						

### 6.7 Electrical Characteristics: ULN2003AI

T<sub>A</sub> = 25°C

PARAMETER	TEST FIGURE	TEST CONDITIONS	ULN2003AI			UNIT
			MIN	TYP	MAX	
V <sub>I(on)</sub> ON-state input voltage	Figure 14	V <sub>CE</sub> = 2 V	I <sub>C</sub> = 200 mA		2.4	V
			I <sub>C</sub> = 250 mA		2.7	
			I <sub>C</sub> = 300 mA		3	
V <sub>OH</sub> High-level output voltage after switching	Figure 18	V <sub>S</sub> = 50 V, I <sub>O</sub> = 300 mA	V <sub>S</sub> – 50			mV
V <sub>CE(sat)</sub> Collector-emitter saturation voltage	Figure 13	I <sub>I</sub> = 250 μA, I <sub>C</sub> = 100 mA	0.9	1.1	V	
		I <sub>I</sub> = 350 μA, I <sub>C</sub> = 200 mA	1	1.3		
		I <sub>I</sub> = 500 μA, I <sub>C</sub> = 350 mA	1.2	1.6		
I <sub>CEX</sub> Collector cutoff current	Figure 9	V <sub>CE</sub> = 50 V, I <sub>I</sub> = 0	50			μA
V <sub>F</sub> Clamp forward voltage	Figure 16	I <sub>F</sub> = 350 mA	1.7	2	V	
I <sub>I(off)</sub> OFF-state input current	Figure 11	V <sub>CE</sub> = 50 V, I <sub>C</sub> = 500 μA	50	65	μA	
I <sub>I</sub> Input current	Figure 12	V <sub>I</sub> = 3.85 V	0.93	1.35	mA	
I <sub>R</sub> Clamp reverse current	Figure 15	V <sub>R</sub> = 50 V	50			μA
C <sub>i</sub> Input capacitance		V <sub>I</sub> = 0, f = 1 MHz	15	25	pF	

### 6.8 Electrical Characteristics: ULN2003AI

T<sub>A</sub> = –40°C to 105°C

PARAMETER	TEST FIGURE	TEST CONDITIONS	ULN2003AI			UNIT
			MIN	TYP	MAX	
V <sub>I(on)</sub> ON-state input voltage	Figure 14	V <sub>CE</sub> = 2 V	I <sub>C</sub> = 200 mA		2.7	V
			I <sub>C</sub> = 250 mA		2.9	
			I <sub>C</sub> = 300 mA		3	
V <sub>OH</sub> High-level output voltage after switching	Figure 18	V <sub>S</sub> = 50 V, I <sub>O</sub> = 300 mA	V <sub>S</sub> – 50			mV
V <sub>CE(sat)</sub> Collector-emitter saturation voltage	Figure 13	I <sub>I</sub> = 250 μA, I <sub>C</sub> = 100 mA	0.9	1.2	V	
		I <sub>I</sub> = 350 μA, I <sub>C</sub> = 200 mA	1	1.4		
		I <sub>I</sub> = 500 μA, I <sub>C</sub> = 350 mA	1.2	1.7		
I <sub>CEX</sub> Collector cutoff current	Figure 9	V <sub>CE</sub> = 50 V, I <sub>I</sub> = 0	100			μA
V <sub>F</sub> Clamp forward voltage	Figure 16	I <sub>F</sub> = 350 mA	1.7	2.2	V	
I <sub>I(off)</sub> OFF-state input current	Figure 11	V <sub>CE</sub> = 50 V, I <sub>C</sub> = 500 μA	30	65	μA	
I <sub>I</sub> Input current	Figure 12	V <sub>I</sub> = 3.85 V	0.93	1.35	mA	
I <sub>R</sub> Clamp reverse current	Figure 15	V <sub>R</sub> = 50 V	100			μA
C <sub>i</sub> Input capacitance		V <sub>I</sub> = 0, f = 1 MHz	15	25	pF	

## 6.9 Electrical Characteristics: ULQ2003A and ULQ2004A

over recommended operating conditions (unless otherwise noted)

PARAMETER	TEST FIGURE	TEST CONDITIONS	ULQ2003A			ULQ2004A			UNIT
			MIN	TYP	MAX	MIN	TYP	MAX	
$V_{I(on)}$ ON-state input voltage	Figure 14	$V_{CE} = 2\text{ V}$	$I_C = 125\text{ mA}$					5	V
			$I_C = 200\text{ mA}$			2.7		6	
			$I_C = 250\text{ mA}$			2.9			
			$I_C = 275\text{ mA}$					7	
			$I_C = 300\text{ mA}$			3			
			$I_C = 350\text{ mA}$					8	
$V_{OH}$ High-level output voltage after switching	Figure 18	$V_S = 50\text{ V}, I_O = 300\text{ mA}$	$V_S - 50$			$V_S - 50$			mV
$V_{CE(sat)}$ Collector-emitter saturation voltage	Figure 13	$I_I = 250\text{ }\mu\text{A}, I_C = 100\text{ mA}$	0.9	1.2		0.9	1.1	V	
		$I_I = 350\text{ }\mu\text{A}, I_C = 200\text{ mA}$	1	1.4		1	1.3		
		$I_I = 500\text{ }\mu\text{A}, I_C = 350\text{ mA}$	1.2	1.7		1.2	1.6		
$I_{CEX}$ Collector cutoff current	Figure 9	$V_{CE} = 50\text{ V}, I_I = 0$	100			50			$\mu\text{A}$
	Figure 10	$V_{CE} = 50\text{ V}, T_A = 70^\circ\text{C}$				100			
		$V_I = 6\text{ V}$				500			
$V_F$ Clamp forward voltage	Figure 16	$I_F = 350\text{ mA}$	1.7	2.3		1.7	2	V	
$I_{I(off)}$ OFF-state input current	Figure 11	$V_{CE} = 50\text{ V}, T_A = 70^\circ\text{C}, I_C = 500\text{ }\mu\text{A}$	65			50	65	$\mu\text{A}$	
$I_I$ Input current	Figure 12	$V_I = 3.85\text{ V}$	0.93	1.35				mA	
		$V_I = 5\text{ V}$				0.35	0.5		
		$V_I = 12\text{ V}$				1	1.45		
$I_R$ Clamp reverse current	Figure 15	$V_R = 50\text{ V}, T_A = 25^\circ\text{C}$	100			50			$\mu\text{A}$
		$V_R = 50\text{ V}$	100			100			
$C_i$ Input capacitance		$V_I = 0, f = 1\text{ MHz}$	15	25		15	25	pF	

## 6.10 Switching Characteristics: ULN2002A, ULN2003A, ULN2004A

 $T_A = 25^\circ\text{C}$ 

PARAMETER	TEST CONDITIONS	ULN2002A, ULN2003A, ULN2004A			UNIT
		MIN	TYP	MAX	
$t_{PLH}$ Propagation delay time, low- to high-level output	See Figure 17		0.25	1	$\mu\text{s}$
$t_{PHL}$ Propagation delay time, high- to low-level output	See Figure 17		0.25	1	$\mu\text{s}$

## 6.11 Switching Characteristics: ULN2003AI

 $T_A = 25^\circ\text{C}$ 

PARAMETER	TEST CONDITIONS	ULN2003AI			UNIT
		MIN	TYP	MAX	
$t_{PLH}$ Propagation delay time, low- to high-level output	See Figure 17		0.25	1	$\mu\text{s}$
$t_{PHL}$ Propagation delay time, high- to low-level output	See Figure 17		0.25	1	$\mu\text{s}$

### 6.12 Switching Characteristics: ULN2003AI

$T_A = -40^{\circ}\text{C}$  to  $105^{\circ}\text{C}$

PARAMETER	TEST CONDITIONS	ULN2003AI			UNIT
		MIN	TYP	MAX	
$t_{PLH}$	Propagation delay time, low- to high-level output		1	10	$\mu\text{s}$
$t_{PHL}$	Propagation delay time, high- to low-level output		1	10	$\mu\text{s}$

### 6.13 Switching Characteristics: ULQ2003A, ULQ2004A

over recommended operating conditions (unless otherwise noted)

PARAMETER	TEST CONDITIONS	ULQ2003A, ULQ2004A			UNIT
		MIN	TYP	MAX	
$t_{PLH}$	Propagation delay time, low- to high-level output		1	10	$\mu\text{s}$
$t_{PHL}$	Propagation delay time, high- to low-level output		1	10	$\mu\text{s}$

### 6.14 Typical Characteristics

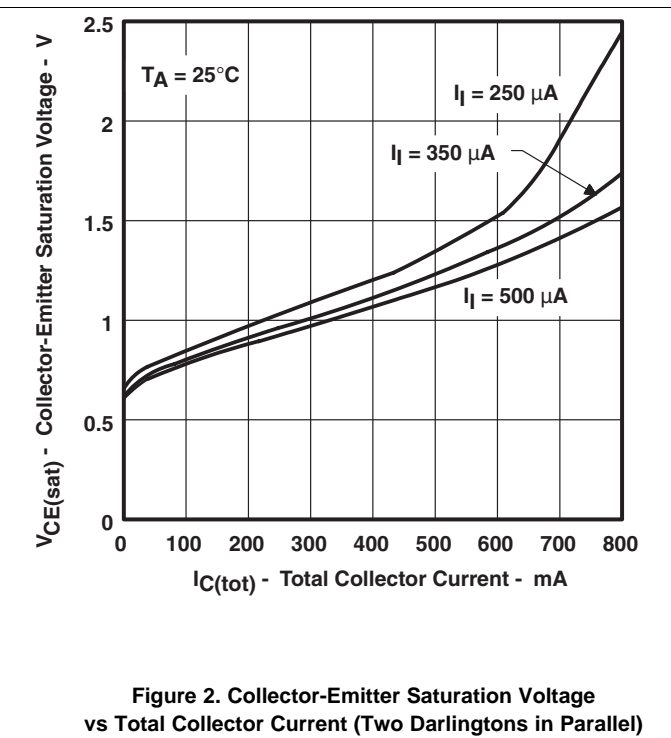
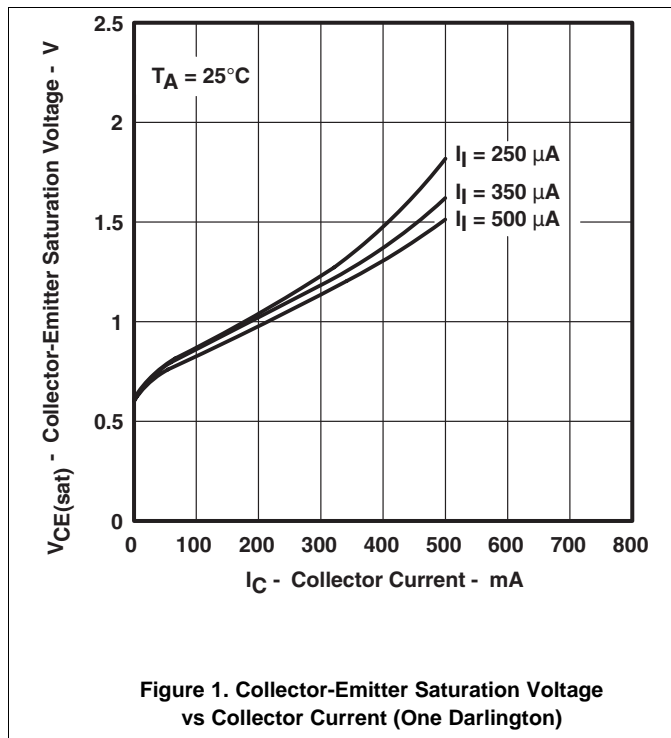

Typical Characteristics (continued)

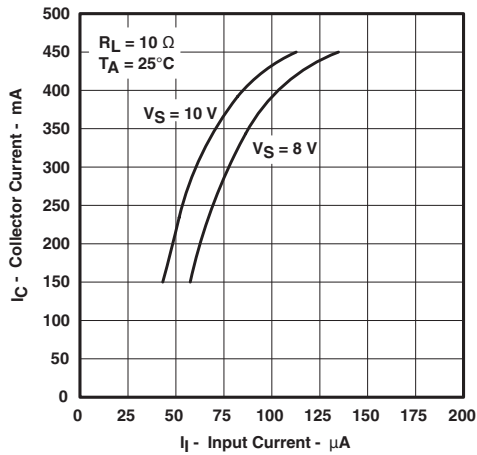

Figure 3. Collector Current vs Input Current

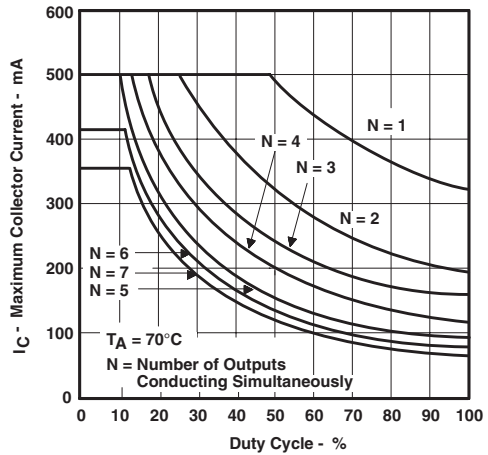

Figure 4. D Package Maximum Collector Current vs Duty Cycle

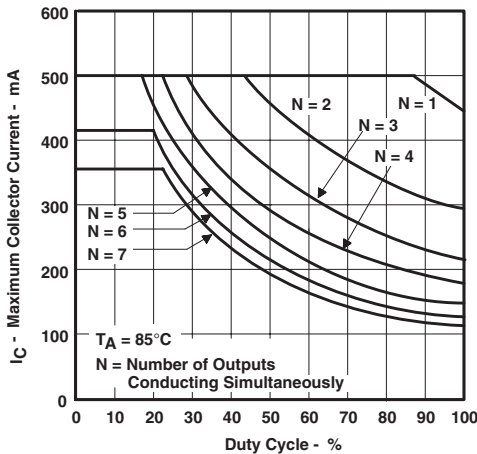

Figure 5. N Package Maximum Collector Current vs Duty Cycle

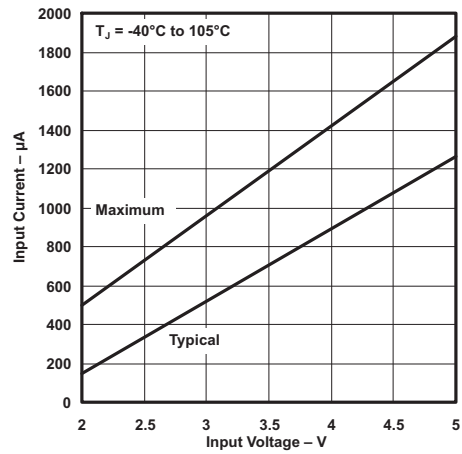

Figure 6. Maximum and Typical Input Current vs Input Voltage

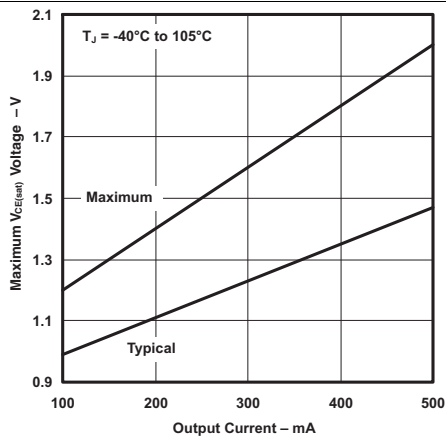

Figure 7. Maximum and Typical Saturated  $V_{CE}$  vs Output Current

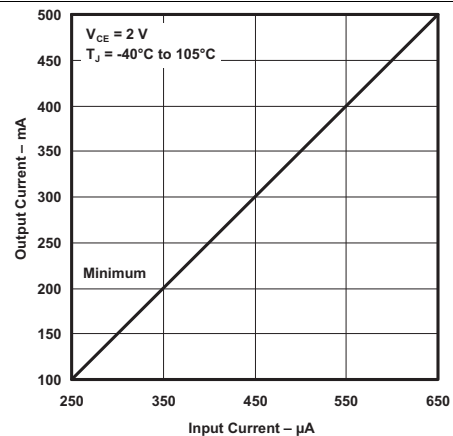

Figure 8. Minimum Output Current vs Input Current

## 7 Parameter Measurement Information

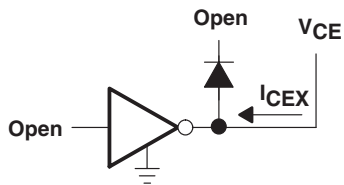

Figure 9.  $I_{CEX}$  Test Circuit

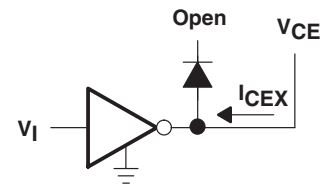

Figure 10.  $I_{CEX}$  Test Circuit

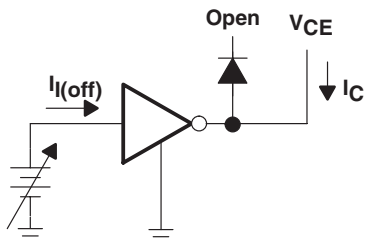

Figure 11.  $I_{I(off)}$  Test Circuit

$I_I$  is fixed for measuring  $V_{CE(sat)}$ , variable for measuring  $h_{FE}$ .

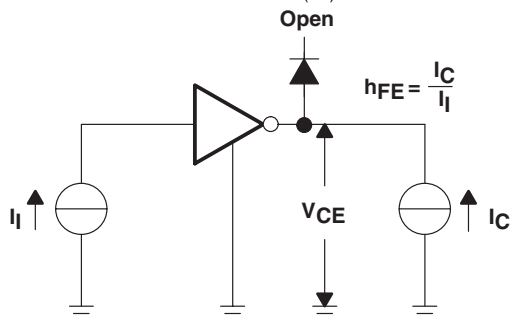

Figure 13.  $h_{FE}$ ,  $V_{CE(sat)}$  Test Circuit

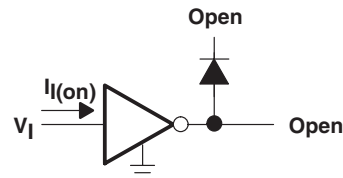

Figure 12.  $I_I$  Test Circuit

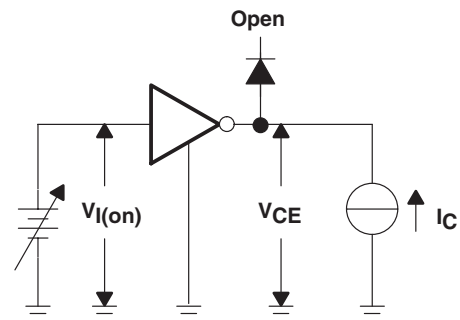

Figure 14.  $V_{I(on)}$  Test Circuit

Parameter Measurement Information (continued)

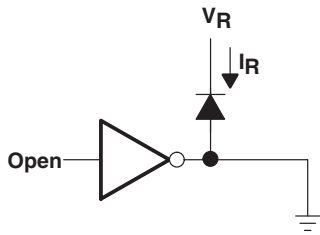

Figure 15.  $I_R$  Test Circuit

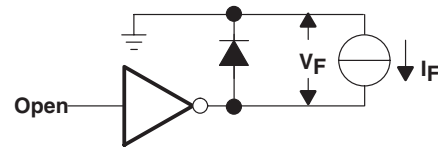

Figure 16.  $V_F$  Test Circuit

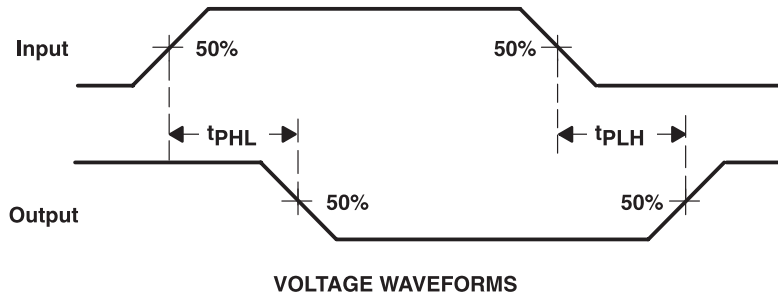
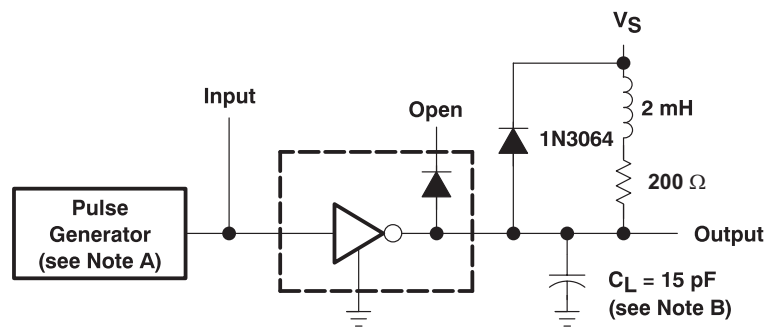
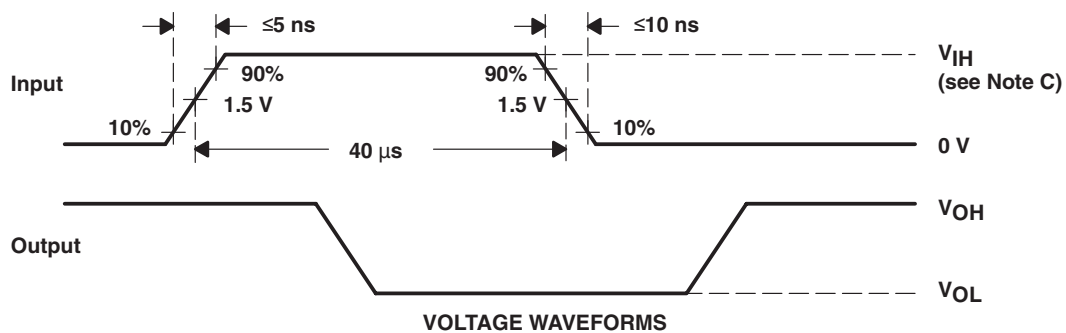

Figure 17. Propagation Delay-Time Waveforms



TEST CIRCUIT



VOLTAGE WAVEFORMS

The pulse generator has the following characteristics: PRR = 12.5 kHz,  $Z_O = 50 \Omega$ .

$C_L$  includes probe and jig capacitance.

For testing the ULN2003A device, ULN2003AI device, and ULQ2003A devices,  $V_{IH} = 3 \text{ V}$ ; for the ULN2002A device,  $V_{IH} = 13 \text{ V}$ ; for the ULN2004A and the ULQ2004A devices,  $V_{IH} = 8 \text{ V}$ .

Figure 18. Latch-Up Test Circuit and Voltage Waveforms

## 8 Detailed Description

### 8.1 Overview

This standard device has proven ubiquity and versatility across a wide range of applications. This is due to integration of 7 Darlington transistors of the device that are capable of sinking up to 500 mA and wide GPIO range capability.

The ULN2003A device comprises seven high-voltage, high-current NPN Darlington transistor pairs. All units feature a common emitter and open collector outputs. To maximize their effectiveness, these units contain suppression diodes for inductive loads. The ULN2003A device has a series base resistor to each Darlington pair, thus allowing operation directly with TTL or CMOS operating at supply voltages of 5 V or 3.3 V. The ULN2003A device offers solutions to a great many interface needs, including solenoids, relays, lamps, small motors, and LEDs. Applications requiring sink currents beyond the capability of a single output may be accommodated by paralleling the outputs.

This device can operate over a wide temperature range (–40°C to 105°C).

### 8.2 Functional Block Diagrams

All resistor values shown are nominal. The collector-emitter diode is a parasitic structure and should not be used to conduct current. If the collectors go below GND, an external Schottky diode should be added to clamp negative undershoots.



Figure 19. ULN2002A Block Diagram



Figure 20. ULN2003A, ULQ2003A and ULN2003AI Block Diagram

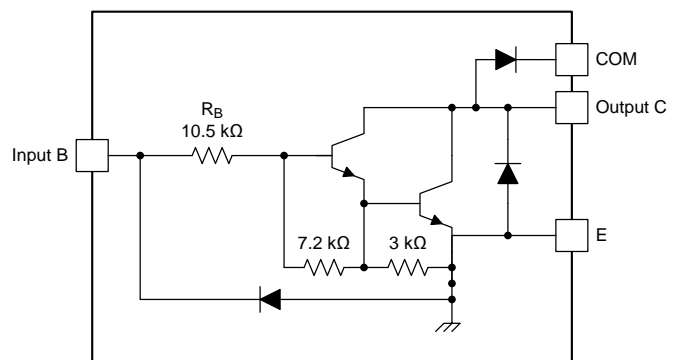

Figure 21. ULN2004A and LQ2004A Block Diagram

### 8.3 Feature Description

Each channel of the ULN2003A device consists of Darlington connected NPN transistors. This connection creates the effect of a single transistor with a very high-current gain ( $\beta^2$ ). This can be as high as 10,000 A/A at certain currents. The very high  $\beta$  allows for high-output current drive with a very low input current, essentially equating to operation with low GPIO voltages.

The GPIO voltage is converted to base current through the 2.7-k $\Omega$  resistor connected between the input and base of the predriver Darlington NPN. The 7.2-k $\Omega$  and 3-k $\Omega$  resistors connected between the base and emitter of each respective NPN act as pulldowns and suppress the amount of leakage that may occur from the input.

The diodes connected between the output and COM pin is used to suppress the kick-back voltage from an inductive load that is excited when the NPN drivers are turned off (stop sinking) and the stored energy in the coils causes a reverse current to flow into the coil supply through the kick-back diode.

In normal operation the diodes on base and collector pins to emitter will be reversed biased. If these diodes are forward biased, internal parasitic NPN transistors will draw (a nearly equal) current from other (nearby) device pins.

### 8.4 Device Functional Modes

#### 8.4.1 Inductive Load Drive

When the COM pin is tied to the coil supply voltage, ULN2003A device is able to drive inductive loads and suppress the kick-back voltage through the internal free-wheeling diodes.

#### 8.4.2 Resistive Load Drive

When driving a resistive load, a pullup resistor is needed in order for ULN2003A device to sink current and for there to be a logic high level. The COM pin can be left floating for these applications.

## 9 Application and Implementation

### NOTE

Information in the following applications sections is not part of the TI component specification, and TI does not warrant its accuracy or completeness. TI's customers are responsible for determining suitability of components for their purposes. Customers should validate and test their design implementation to confirm system functionality.

### 9.1 Application Information

Typically, the ULN2003A device drives a high-voltage or high-current (or both) peripheral from an MCU or logic device that cannot tolerate these conditions. This design is a common application of ULN2003A device, driving inductive loads. This includes motors, solenoids and relays. Figure 22 shows a model for each load type.

### 9.2 Typical Application



Figure 22. ULN2003A Device as Inductive Load Driver

#### 9.2.1 Design Requirements

For this design example, use the parameters listed in Table 1 as the input parameters.

Table 1. Design Parameters

DESIGN PARAMETER	EXAMPLE VALUE
GPIO voltage	3.3 V or 5 V
Coil supply voltage	12 V to 48 V
Number of channels	7
Output current ( $R_{COIL}$ )	20 mA to 300 mA per channel
Duty cycle	100%

## 9.2.2 Detailed Design Procedure

When using ULN2003A device in a coil driving application, determine the following:

- Input voltage range
- Temperature range
- Output and drive current
- Power dissipation

### 9.2.2.1 Drive Current

The coil voltage ( $V_{SUP}$ ), coil resistance ( $R_{COIL}$ ), and low-level output voltage ( $V_{CE(SAT)}$  or  $V_{OL}$ ) determine the coil current.

$$I_{COIL} = (V_{SUP} - V_{CE(SAT)}) / R_{COIL} \quad (1)$$

### 9.2.2.2 Low-Level Output Voltage

The low-level output voltage ( $V_{OL}$ ) is the same as  $V_{CE(SAT)}$  and can be determined by, [Figure 1](#), [Figure 2](#), or [Figure 7](#).

### 9.2.2.3 Power Dissipation and Temperature

The number of coils driven is dependent on the coil current and on-chip power dissipation. The number of coils driven can be determined by [Figure 4](#) or [Figure 5](#).

For a more accurate determination of number of coils possible, use the below equation to calculate ULN2003A device on-chip power dissipation  $P_D$ :

$$P_D = \sum_{i=1}^N V_{OLi} \times I_{Li}$$

where

- $N$  is the number of channels active together
- $V_{OLi}$  is the  $OUT_i$  pin voltage for the load current  $I_{Li}$ . This is the same as  $V_{CE(SAT)}$  (2)

To ensure reliability of ULN2003A device and the system, the on-chip power dissipation must be lower than or equal to the maximum allowable power dissipation ( $PD_{(MAX)}$ ) dictated by below equation [Equation 3](#).

$$PD_{(MAX)} = \frac{(T_{J(MAX)} - T_A)}{\theta_{JA}}$$

where

- $T_{J(max)}$  is the target maximum junction temperature
- $T_A$  is the operating ambient temperature
- $R_{\theta JA}$  is the package junction to ambient thermal resistance (3)

Limit the die junction temperature of the ULN2003A device to less than 125°C. The IC junction temperature is directly proportional to the on-chip power dissipation.

### 9.2.3 Application Curves

The characterization data shown in [Figure 23](#) and [Figure 24](#) were generated using the ULN2003A device driving an OMRON G5NB relay and under the following conditions:  $V_{IN} = 5\text{ V}$ ,  $V_{SUP} = 12\text{ V}$ , and  $R_{COIL} = 2.8\text{ k}\Omega$ .

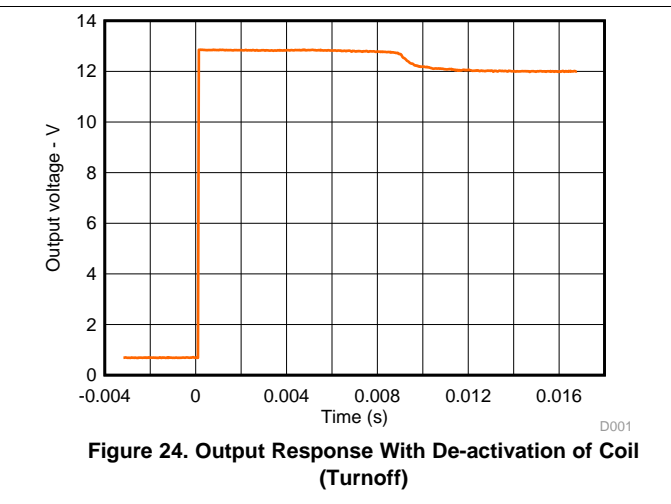
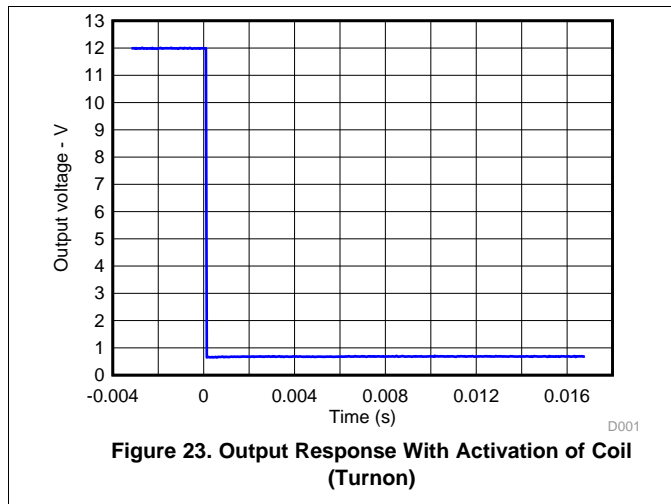

### 9.3 System Examples



Figure 25. P-MOS to Load

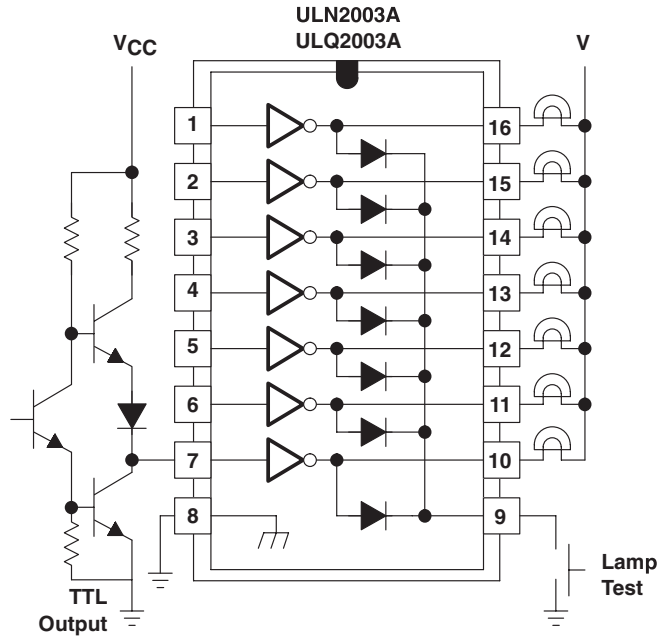

Figure 26. TTL to Load

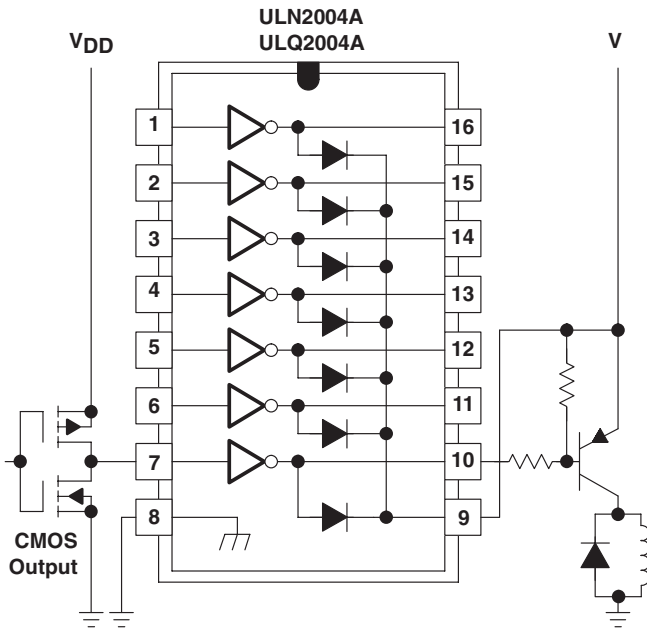

Figure 27. Buffer for Higher Current Loads

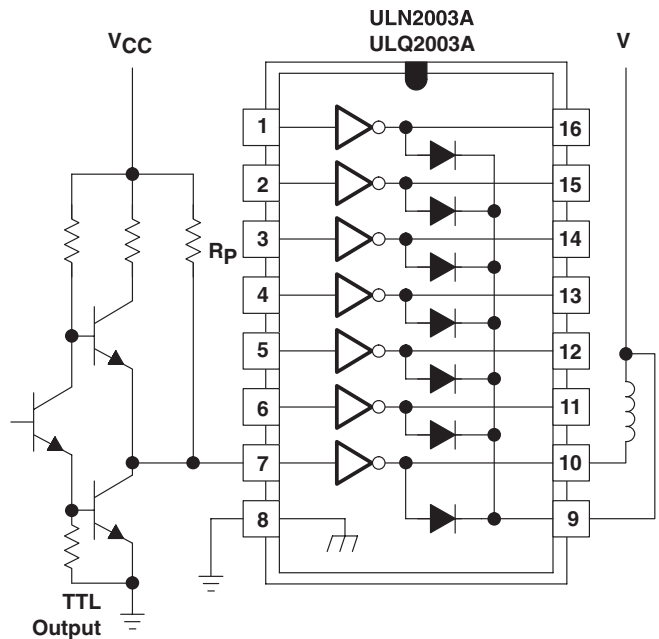

Figure 28. Use of Pullup Resistors to Increase Drive Current

## 10 Power Supply Recommendations

This device does not need a power supply. However, the COM pin is typically tied to the system power supply. When this is the case, it is very important to ensure that the output voltage does not heavily exceed the COM pin voltage. This discrepancy heavily forward biases the fly-back diodes and causes a large current to flow into COM, potentially damaging the on-chip metal or over-heating the device.

## 11 Layout

### 11.1 Layout Guidelines

Thin traces can be used on the input due to the low-current logic that is typically used to drive ULN2003A device. Take care to separate the input channels as much as possible, as to eliminate crosstalk. TI recommends thick traces for the output to drive whatever high currents that may be needed. Wire thickness can be determined by the current density of the trace material and desired drive current.

Because all of the channels currents return to a common emitter, it is best to size that trace width to be very wide. Some applications require up to 2.5 A.

### 11.2 Layout Example

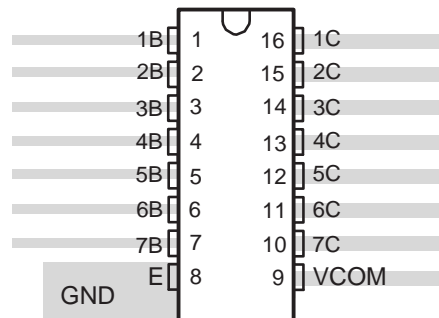

Figure 29. Package Layout

## 12 Device and Documentation Support

### 12.1 Documentation Support

#### 12.1.1 Related Documentation

For related documentation, see the following:

*SN7546x Darlington Transistor Arrays*, [SLRS023](#)

### 12.2 Related Links

The table below lists quick access links. Categories include technical documents, support and community resources, tools and software, and quick access to sample or buy.

**Table 2. Related Links**

PARTS	PRODUCT FOLDER	SAMPLE & BUY	TECHNICAL DOCUMENTS	TOOLS & SOFTWARE	SUPPORT & COMMUNITY
ULN2002A	<a href="#">Click here</a>	<a href="#">Click here</a>	<a href="#">Click here</a>	<a href="#">Click here</a>	<a href="#">Click here</a>
ULN2003A	<a href="#">Click here</a>	<a href="#">Click here</a>	<a href="#">Click here</a>	<a href="#">Click here</a>	<a href="#">Click here</a>
ULN2003AI	<a href="#">Click here</a>	<a href="#">Click here</a>	<a href="#">Click here</a>	<a href="#">Click here</a>	<a href="#">Click here</a>
ULN2004A	<a href="#">Click here</a>	<a href="#">Click here</a>	<a href="#">Click here</a>	<a href="#">Click here</a>	<a href="#">Click here</a>
ULQ2003A	<a href="#">Click here</a>	<a href="#">Click here</a>	<a href="#">Click here</a>	<a href="#">Click here</a>	<a href="#">Click here</a>
ULQ2004A	<a href="#">Click here</a>	<a href="#">Click here</a>	<a href="#">Click here</a>	<a href="#">Click here</a>	<a href="#">Click here</a>

### 12.3 Community Resources

The following links connect to TI community resources. Linked contents are provided "AS IS" by the respective contributors. They do not constitute TI specifications and do not necessarily reflect TI's views; see TI's [Terms of Use](#).

**TI E2E™ Online Community** *TI's Engineer-to-Engineer (E2E) Community*. Created to foster collaboration among engineers. At [e2e.ti.com](http://e2e.ti.com), you can ask questions, share knowledge, explore ideas and help solve problems with fellow engineers.

**Design Support** *TI's Design Support* Quickly find helpful E2E forums along with design support tools and contact information for technical support.

### 12.4 Trademarks

E2E is a trademark of Texas Instruments.  
All other trademarks are the property of their respective owners.

### 12.5 Electrostatic Discharge Caution



These devices have limited built-in ESD protection. The leads should be shorted together or the device placed in conductive foam during storage or handling to prevent electrostatic damage to the MOS gates.

### 12.6 Glossary

[SLYZ022](#) — *TI Glossary*.

This glossary lists and explains terms, acronyms, and definitions.

## 13 Mechanical, Packaging, and Orderable Information

The following pages include mechanical packaging and orderable information. This information is the most current data available for the designated devices. This data is subject to change without notice and revision of this document. For browser based versions of this data sheet, refer to the left hand navigation.

**PACKAGING INFORMATION**

Orderable Device	Status (1)	Package Type	Package Drawing	Pins	Package Qty	Eco Plan (2)	Lead/Ball Finish (6)	MSL Peak Temp (3)	Op Temp (°C)	Device Marking (4/5)	Samples
ULN2002AN	ACTIVE	PDIP	N	16	25	Green (RoHS & no Sb/Br)	CU NIPDAU	N / A for Pkg Type	-20 to 70	ULN2002AN	<a href="#">Samples</a>
ULN2002ANE4	ACTIVE	PDIP	N	16	25	Green (RoHS & no Sb/Br)	CU NIPDAU	N / A for Pkg Type	-20 to 70	ULN2002AN	<a href="#">Samples</a>
ULN2003AD	ACTIVE	SOIC	D	16	40	Green (RoHS & no Sb/Br)	CU NIPDAU	Level-1-260C-UNLIM	-20 to 70	ULN2003A	<a href="#">Samples</a>
ULN2003ADE4	ACTIVE	SOIC	D	16	40	Green (RoHS & no Sb/Br)	CU NIPDAU	Level-1-260C-UNLIM	-20 to 70	ULN2003A	<a href="#">Samples</a>
ULN2003ADR	ACTIVE	SOIC	D	16	2500	Green (RoHS & no Sb/Br)	CU NIPDAU   CU SN	Level-1-260C-UNLIM	-20 to 70	ULN2003A	<a href="#">Samples</a>
ULN2003ADRE4	ACTIVE	SOIC	D	16	2500	Green (RoHS & no Sb/Br)	CU NIPDAU	Level-1-260C-UNLIM	-20 to 70	ULN2003A	<a href="#">Samples</a>
ULN2003ADRG3	ACTIVE	SOIC	D	16	2500	Green (RoHS & no Sb/Br)	CU SN	Level-1-260C-UNLIM	-20 to 70	ULN2003A	<a href="#">Samples</a>
ULN2003ADRG4	ACTIVE	SOIC	D	16	2500	Green (RoHS & no Sb/Br)	CU NIPDAU	Level-1-260C-UNLIM	-20 to 70	ULN2003A	<a href="#">Samples</a>
ULN2003AID	ACTIVE	SOIC	D	16	40	Green (RoHS & no Sb/Br)	CU NIPDAU	Level-1-260C-UNLIM	-40 to 105	ULN2003AI	<a href="#">Samples</a>
ULN2003AIDE4	ACTIVE	SOIC	D	16	40	Green (RoHS & no Sb/Br)	CU NIPDAU	Level-1-260C-UNLIM	-40 to 105	ULN2003AI	<a href="#">Samples</a>
ULN2003AIDG4	ACTIVE	SOIC	D	16	40	Green (RoHS & no Sb/Br)	CU NIPDAU	Level-1-260C-UNLIM	-40 to 105	ULN2003AI	<a href="#">Samples</a>
ULN2003AIDR	ACTIVE	SOIC	D	16	2500	Green (RoHS & no Sb/Br)	CU NIPDAU   CU SN	Level-1-260C-UNLIM	-40 to 105	ULN2003AI	<a href="#">Samples</a>
ULN2003AIDRE4	ACTIVE	SOIC	D	16	2500	Green (RoHS & no Sb/Br)	CU NIPDAU	Level-1-260C-UNLIM	-40 to 105	ULN2003AI	<a href="#">Samples</a>
ULN2003AIDRG4	ACTIVE	SOIC	D	16	2500	Green (RoHS & no Sb/Br)	CU NIPDAU	Level-1-260C-UNLIM	-40 to 105	ULN2003AI	<a href="#">Samples</a>
ULN2003AIN	ACTIVE	PDIP	N	16	25	Green (RoHS & no Sb/Br)	CU NIPDAU   CU SN	N / A for Pkg Type	-40 to 105	ULN2003AIN	<a href="#">Samples</a>
ULN2003AINE4	ACTIVE	PDIP	N	16	25	Green (RoHS & no Sb/Br)	CU NIPDAU	N / A for Pkg Type	-40 to 105	ULN2003AIN	<a href="#">Samples</a>
ULN2003AINSR	ACTIVE	SO	NS	16	2000	Green (RoHS & no Sb/Br)	CU NIPDAU	Level-1-260C-UNLIM	-40 to 105	ULN2003AI	<a href="#">Samples</a>

Orderable Device	Status (1)	Package Type	Package Drawing	Pins	Package Qty	Eco Plan (2)	Lead/Ball Finish (6)	MSL Peak Temp (3)	Op Temp (°C)	Device Marking (4/5)	Samples
ULN2003AIPW	ACTIVE	TSSOP	PW	16	90	Green (RoHS & no Sb/Br)	CU NIPDAU	Level-1-260C-UNLIM	-40 to 105	UN2003AI	<a href="#">Samples</a>
ULN2003AIPWR	ACTIVE	TSSOP	PW	16	2000	Green (RoHS & no Sb/Br)	CU NIPDAU   CU SN	Level-1-260C-UNLIM	-40 to 105	UN2003AI	<a href="#">Samples</a>
ULN2003AIPWRG4	ACTIVE	TSSOP	PW	16	2000	Green (RoHS & no Sb/Br)	CU NIPDAU	Level-1-260C-UNLIM	-40 to 105	UN2003AI	<a href="#">Samples</a>
ULN2003AN	ACTIVE	PDIP	N	16	25	Green (RoHS & no Sb/Br)	CU NIPDAU   CU SN	N / A for Pkg Type	-20 to 70	ULN2003AN	<a href="#">Samples</a>
ULN2003ANE4	ACTIVE	PDIP	N	16	25	Green (RoHS & no Sb/Br)	CU NIPDAU	N / A for Pkg Type	-20 to 70	ULN2003AN	<a href="#">Samples</a>
ULN2003ANS	ACTIVE	SO	NS	16	50	Green (RoHS & no Sb/Br)	CU NIPDAU	Level-1-260C-UNLIM		ULN2003A	<a href="#">Samples</a>
ULN2003ANSR	ACTIVE	SO	NS	16	2000	Green (RoHS & no Sb/Br)	CU NIPDAU	Level-1-260C-UNLIM	-20 to 70	ULN2003A	<a href="#">Samples</a>
ULN2003ANSRE4	ACTIVE	SO	NS	16	2000	Green (RoHS & no Sb/Br)	CU NIPDAU	Level-1-260C-UNLIM	-20 to 70	ULN2003A	<a href="#">Samples</a>
ULN2003ANSRG4	ACTIVE	SO	NS	16	2000	Green (RoHS & no Sb/Br)	CU NIPDAU	Level-1-260C-UNLIM	-20 to 70	ULN2003A	<a href="#">Samples</a>
ULN2003APW	ACTIVE	TSSOP	PW	16	90	Green (RoHS & no Sb/Br)	CU NIPDAU	Level-1-260C-UNLIM	-20 to 70	UN2003A	<a href="#">Samples</a>
ULN2003APWG4	ACTIVE	TSSOP	PW	16	90	Green (RoHS & no Sb/Br)	CU NIPDAU	Level-1-260C-UNLIM	-20 to 70	UN2003A	<a href="#">Samples</a>
ULN2003APWR	ACTIVE	TSSOP	PW	16	2000	Green (RoHS & no Sb/Br)	CU NIPDAU   CU SN	Level-1-260C-UNLIM	-20 to 70	UN2003A	<a href="#">Samples</a>
ULN2003APWRG4	ACTIVE	TSSOP	PW	16	2000	Green (RoHS & no Sb/Br)	CU NIPDAU	Level-1-260C-UNLIM	-20 to 70	UN2003A	<a href="#">Samples</a>
ULN2004AD	ACTIVE	SOIC	D	16	40	Green (RoHS & no Sb/Br)	CU NIPDAU	Level-1-260C-UNLIM	-20 to 70	ULN2004A	<a href="#">Samples</a>
ULN2004ADE4	ACTIVE	SOIC	D	16	40	Green (RoHS & no Sb/Br)	CU NIPDAU	Level-1-260C-UNLIM	-20 to 70	ULN2004A	<a href="#">Samples</a>
ULN2004ADG4	ACTIVE	SOIC	D	16	40	Green (RoHS & no Sb/Br)	CU NIPDAU	Level-1-260C-UNLIM	-20 to 70	ULN2004A	<a href="#">Samples</a>
ULN2004ADR	ACTIVE	SOIC	D	16	2500	Green (RoHS & no Sb/Br)	CU NIPDAU   CU SN	Level-1-260C-UNLIM	-20 to 70	ULN2004A	<a href="#">Samples</a>
ULN2004ADRE4	ACTIVE	SOIC	D	16	2500	Green (RoHS & no Sb/Br)	CU NIPDAU	Level-1-260C-UNLIM	-20 to 70	ULN2004A	<a href="#">Samples</a>

Orderable Device	Status (1)	Package Type	Package Drawing	Pins	Package Qty	Eco Plan (2)	Lead/Ball Finish (6)	MSL Peak Temp (3)	Op Temp (°C)	Device Marking (4/5)	Samples
ULN2004ADRG4	ACTIVE	SOIC	D	16	2500	Green (RoHS & no Sb/Br)	CU NIPDAU	Level-1-260C-UNLIM	-20 to 70	ULN2004A	<a href="#">Samples</a>
ULN2004AN	ACTIVE	PDIP	N	16	25	Green (RoHS & no Sb/Br)	CU NIPDAU	N / A for Pkg Type	-20 to 70	ULN2004AN	<a href="#">Samples</a>
ULN2004ANE4	ACTIVE	PDIP	N	16	25	Green (RoHS & no Sb/Br)	CU NIPDAU	N / A for Pkg Type	-20 to 70	ULN2004AN	<a href="#">Samples</a>
ULN2004ANSR	ACTIVE	SO	NS	16	2000	Green (RoHS & no Sb/Br)	CU NIPDAU	Level-1-260C-UNLIM	-20 to 70	ULN2004A	<a href="#">Samples</a>
ULQ2003AD	ACTIVE	SOIC	D	16	40	Green (RoHS & no Sb/Br)	CU NIPDAU	Level-1-260C-UNLIM	-40 to 85	ULQ2003A	<a href="#">Samples</a>
ULQ2003ADG4	ACTIVE	SOIC	D	16	40	Green (RoHS & no Sb/Br)	CU NIPDAU	Level-1-260C-UNLIM		ULQ2003A	<a href="#">Samples</a>
ULQ2003ADR	ACTIVE	SOIC	D	16	2500	Green (RoHS & no Sb/Br)	CU NIPDAU	Level-1-260C-UNLIM	-40 to 85	ULQ2003A	<a href="#">Samples</a>
ULQ2003ADRG4	ACTIVE	SOIC	D	16	2500	Green (RoHS & no Sb/Br)	CU NIPDAU	Level-1-260C-UNLIM		ULQ2003A	<a href="#">Samples</a>
ULQ2003AN	ACTIVE	PDIP	N	16	25	Pb-Free (RoHS)	CU NIPDAU	N / A for Pkg Type	-40 to 85	ULQ2003A	<a href="#">Samples</a>
ULQ2004AD	ACTIVE	SOIC	D	16	40	Green (RoHS & no Sb/Br)	CU NIPDAU	Level-1-260C-UNLIM	-40 to 85	ULQ2004A	<a href="#">Samples</a>
ULQ2004ADG4	ACTIVE	SOIC	D	16	40	Green (RoHS & no Sb/Br)	CU NIPDAU	Level-1-260C-UNLIM		ULQ2004A	<a href="#">Samples</a>
ULQ2004ADR	ACTIVE	SOIC	D	16	2500	Green (RoHS & no Sb/Br)	CU NIPDAU	Level-1-260C-UNLIM	-40 to 85	ULQ2004A	<a href="#">Samples</a>
ULQ2004ADRG4	ACTIVE	SOIC	D	16	2500	Green (RoHS & no Sb/Br)	CU NIPDAU	Level-1-260C-UNLIM		ULQ2004A	<a href="#">Samples</a>
ULQ2004AN	ACTIVE	PDIP	N	16	25	Pb-Free (RoHS)	CU NIPDAU	N / A for Pkg Type	-40 to 85	ULQ2004AN	<a href="#">Samples</a>

(1) The marketing status values are defined as follows:

**ACTIVE:** Product device recommended for new designs.

**LIFEBUY:** TI has announced that the device will be discontinued, and a lifetime-buy period is in effect.

**NRND:** Not recommended for new designs. Device is in production to support existing customers, but TI does not recommend using this part in a new design.

**PREVIEW:** Device has been announced but is not in production. Samples may or may not be available.

**OBSOLETE:** TI has discontinued the production of the device.

(2) **RoHS:** TI defines "RoHS" to mean semiconductor products that are compliant with the current EU RoHS requirements for all 10 RoHS substances, including the requirement that RoHS substance do not exceed 0.1% by weight in homogeneous materials. Where designed to be soldered at high temperatures, "RoHS" products are suitable for use in specified lead-free processes. TI may reference these types of products as "Pb-Free".

**RoHS Exempt:** TI defines "RoHS Exempt" to mean products that contain lead but are compliant with EU RoHS pursuant to a specific EU RoHS exemption.

**Green:** TI defines "Green" to mean the content of Chlorine (Cl) and Bromine (Br) based flame retardants meet JS709B low halogen requirements of  $\leq 1000$ ppm threshold. Antimony trioxide based flame retardants must also meet the  $\leq 1000$ ppm threshold requirement.

(3) MSL, Peak Temp. - The Moisture Sensitivity Level rating according to the JEDEC industry standard classifications, and peak solder temperature.

(4) There may be additional marking, which relates to the logo, the lot trace code information, or the environmental category on the device.

(5) Multiple Device Markings will be inside parentheses. Only one Device Marking contained in parentheses and separated by a "~" will appear on a device. If a line is indented then it is a continuation of the previous line and the two combined represent the entire Device Marking for that device.

(6) Lead/Ball Finish - Orderable Devices may have multiple material finish options. Finish options are separated by a vertical ruled line. Lead/Ball Finish values may wrap to two lines if the finish value exceeds the maximum column width.

**Important Information and Disclaimer:** The information provided on this page represents TI's knowledge and belief as of the date that it is provided. TI bases its knowledge and belief on information provided by third parties, and makes no representation or warranty as to the accuracy of such information. Efforts are underway to better integrate information from third parties. TI has taken and continues to take reasonable steps to provide representative and accurate information but may not have conducted destructive testing or chemical analysis on incoming materials and chemicals. TI and TI suppliers consider certain information to be proprietary, and thus CAS numbers and other limited information may not be available for release.

In no event shall TI's liability arising out of such information exceed the total purchase price of the TI part(s) at issue in this document sold by TI to Customer on an annual basis.

#### **OTHER QUALIFIED VERSIONS OF ULQ2003A, ULQ2004A :**

- Automotive: [ULQ2003A-Q1](#), [ULQ2004A-Q1](#)

NOTE: Qualified Version Definitions:

- Automotive - Q100 devices qualified for high-reliability automotive applications targeting zero defects

**TAPE AND REEL INFORMATION**

**QUADRANT ASSIGNMENTS FOR PIN 1 ORIENTATION IN TAPE**

\*All dimensions are nominal

Device	Package Type	Package Drawing	Pins	SPQ	Reel Diameter (mm)	Reel Width W1 (mm)	A0 (mm)	B0 (mm)	K0 (mm)	P1 (mm)	W (mm)	Pin1 Quadrant
ULN2003ADR	SOIC	D	16	2500	330.0	16.4	6.5	10.3	2.1	8.0	16.0	Q1
ULN2003ADR	SOIC	D	16	2500	330.0	16.4	6.5	10.3	2.1	8.0	16.0	Q1
ULN2003ADRG4	SOIC	D	16	2500	330.0	16.4	6.5	10.3	2.1	8.0	16.0	Q1
ULN2003AIDR	SOIC	D	16	2500	330.0	16.4	6.5	10.3	2.1	8.0	16.0	Q1
ULN2003AIDRG4	SOIC	D	16	2500	330.0	16.4	6.5	10.3	2.1	8.0	16.0	Q1
ULN2003AIPWR	TSSOP	PW	16	2000	330.0	12.4	6.9	5.6	1.6	8.0	12.0	Q1
ULN2003AIPWRG4	TSSOP	PW	16	2000	330.0	12.4	6.9	5.6	1.6	8.0	12.0	Q1
ULN2003APWR	TSSOP	PW	16	2000	330.0	12.4	6.9	5.6	1.6	8.0	12.0	Q1
ULN2003APWRG4	TSSOP	PW	16	2000	330.0	12.4	6.9	5.6	1.6	8.0	12.0	Q1
ULN2004ADR	SOIC	D	16	2500	330.0	16.4	6.5	10.3	2.1	8.0	16.0	Q1
ULN2004ADR	SOIC	D	16	2500	330.0	16.4	6.5	10.3	2.1	8.0	16.0	Q1
ULN2004ADR	SOIC	D	16	2500	330.0	16.8	6.5	10.3	2.1	8.0	16.0	Q1
ULN2004ADRG4	SOIC	D	16	2500	330.0	16.4	6.5	10.3	2.1	8.0	16.0	Q1
ULN2004ADRG4	SOIC	D	16	2500	330.0	16.4	6.5	10.3	2.1	8.0	16.0	Q1
ULQ2003ADR	SOIC	D	16	2500	330.0	16.4	6.5	10.3	2.1	8.0	16.0	Q1
ULQ2003ADRG4	SOIC	D	16	2500	330.0	16.4	6.5	10.3	2.1	8.0	16.0	Q1

**TAPE AND REEL BOX DIMENSIONS**

\*All dimensions are nominal

Device	Package Type	Package Drawing	Pins	SPQ	Length (mm)	Width (mm)	Height (mm)
ULN2003ADR	SOIC	D	16	2500	333.2	345.9	28.6
ULN2003ADR	SOIC	D	16	2500	367.0	367.0	38.0
ULN2003ADRG4	SOIC	D	16	2500	333.2	345.9	28.6
ULN2003AIDR	SOIC	D	16	2500	333.2	345.9	28.6
ULN2003AIDRG4	SOIC	D	16	2500	333.2	345.9	28.6
ULN2003AIPWR	TSSOP	PW	16	2000	367.0	367.0	35.0
ULN2003AIPWRG4	TSSOP	PW	16	2000	367.0	367.0	35.0
ULN2003APWR	TSSOP	PW	16	2000	367.0	367.0	35.0
ULN2003APWRG4	TSSOP	PW	16	2000	367.0	367.0	35.0
ULN2004ADR	SOIC	D	16	2500	367.0	367.0	38.0
ULN2004ADR	SOIC	D	16	2500	333.2	345.9	28.6
ULN2004ADR	SOIC	D	16	2500	364.0	364.0	27.0
ULN2004ADRG4	SOIC	D	16	2500	367.0	367.0	38.0
ULN2004ADRG4	SOIC	D	16	2500	333.2	345.9	28.6
ULQ2003ADR	SOIC	D	16	2500	333.2	345.9	28.6
ULQ2003ADRG4	SOIC	D	16	2500	367.0	367.0	38.0

D (R-PDSO-G16)

PLASTIC SMALL OUTLINE



- NOTES:
- A. All linear dimensions are in inches (millimeters).
  - B. This drawing is subject to change without notice.
  - C. Body length does not include mold flash, protrusions, or gate burrs. Mold flash, protrusions, or gate burrs shall not exceed 0.006 (0,15) each side.
  - D. Body width does not include interlead flash. Interlead flash shall not exceed 0.017 (0,43) each side.
  - E. Reference JEDEC MS-012 variation AC.

D (R-PDSO-G16)

PLASTIC SMALL OUTLINE



- NOTES:
- A. All linear dimensions are in millimeters.
  - B. This drawing is subject to change without notice.
  - C. Publication IPC-7351 is recommended for alternate designs.
  - D. Laser cutting apertures with trapezoidal walls and also rounding corners will offer better paste release. Customers should contact their board assembly site for stencil design recommendations. Refer to IPC-7525 for other stencil recommendations.
  - E. Customers should contact their board fabrication site for solder mask tolerances between and around signal pads.



4220204/A 02/2017

NOTES:

1. All linear dimensions are in millimeters. Any dimensions in parenthesis are for reference only. Dimensioning and tolerancing per ASME Y14.5M.
2. This drawing is subject to change without notice.
3. This dimension does not include mold flash, protrusions, or gate burrs. Mold flash, protrusions, or gate burrs shall not exceed 0.15 mm per side.
4. This dimension does not include interlead flash. Interlead flash shall not exceed 0.25 mm per side.
5. Reference JEDEC registration MO-153.

# EXAMPLE BOARD LAYOUT

PW0016A

TSSOP - 1.2 mm max height

SMALL OUTLINE PACKAGE



LAND PATTERN EXAMPLE  
EXPOSED METAL SHOWN  
SCALE: 10X



SOLDER MASK DETAILS

4220204/A 02/2017

NOTES: (continued)

- 6. Publication IPC-7351 may have alternate designs.
- 7. Solder mask tolerances between and around signal pads can vary based on board fabrication site.

# EXAMPLE STENCIL DESIGN

PW0016A

TSSOP - 1.2 mm max height

SMALL OUTLINE PACKAGE



SOLDER PASTE EXAMPLE  
BASED ON 0.125 mm THICK STENCIL  
SCALE: 10X

4220204/A 02/2017

NOTES: (continued)

8. Laser cutting apertures with trapezoidal walls and rounded corners may offer better paste release. IPC-7525 may have alternate design recommendations.
9. Board assembly site may have different recommendations for stencil design.

# MECHANICAL DATA

NS (R-PDSO-G\*\*)

PLASTIC SMALL-OUTLINE PACKAGE

14-PINS SHOWN



- NOTES:
- A. All linear dimensions are in millimeters.
  - B. This drawing is subject to change without notice.
  - C. Body dimensions do not include mold flash or protrusion, not to exceed 0,15.

N (R-PDIP-T\*\*)

PLASTIC DUAL-IN-LINE PACKAGE

16 PINS SHOWN



- NOTES:
- A. All linear dimensions are in inches (millimeters).
  - B. This drawing is subject to change without notice.
  - Falls within JEDEC MS-001, except 18 and 20 pin minimum body length (Dim A).
  - The 20 pin end lead shoulder width is a vendor option, either half or full width.

4040049/E 12/2002

## IMPORTANT NOTICE AND DISCLAIMER

TI PROVIDES TECHNICAL AND RELIABILITY DATA (INCLUDING DATASHEETS), DESIGN RESOURCES (INCLUDING REFERENCE DESIGNS), APPLICATION OR OTHER DESIGN ADVICE, WEB TOOLS, SAFETY INFORMATION, AND OTHER RESOURCES "AS IS" AND WITH ALL FAULTS, AND DISCLAIMS ALL WARRANTIES, EXPRESS AND IMPLIED, INCLUDING WITHOUT LIMITATION ANY IMPLIED WARRANTIES OF MERCHANTABILITY, FITNESS FOR A PARTICULAR PURPOSE OR NON-INFRINGEMENT OF THIRD PARTY INTELLECTUAL PROPERTY RIGHTS.

These resources are intended for skilled developers designing with TI products. You are solely responsible for (1) selecting the appropriate TI products for your application, (2) designing, validating and testing your application, and (3) ensuring your application meets applicable standards, and any other safety, security, or other requirements. These resources are subject to change without notice. TI grants you permission to use these resources only for development of an application that uses the TI products described in the resource. Other reproduction and display of these resources is prohibited. No license is granted to any other TI intellectual property right or to any third party intellectual property right. TI disclaims responsibility for, and you will fully indemnify TI and its representatives against, any claims, damages, costs, losses, and liabilities arising out of your use of these resources.

TI's products are provided subject to TI's Terms of Sale ([www.ti.com/legal/termsofsale.html](http://www.ti.com/legal/termsofsale.html)) or other applicable terms available either on [ti.com](http://ti.com) or provided in conjunction with such TI products. TI's provision of these resources does not expand or otherwise alter TI's applicable warranties or warranty disclaimers for TI products.

Mailing Address: Texas Instruments, Post Office Box 655303, Dallas, Texas 75265  
Copyright © 2019, Texas Instruments Incorporated

## Looking for pricing, stock, or lifecycle information?

Click below to explore more details on WIN SOURCE:

 [View ULN2003AD](#) on WIN SOURCE

 [Texas Instruments](#) Information

## Optimize Your Supply Chain with WIN SOURCE Solutions

-  Global Sourcing Solution
-  Obsolete Management
-  Cost Control Management
-  Shortage Management
-  Alternative Solution
-  Excess Inventory Management