

DATA SHEET

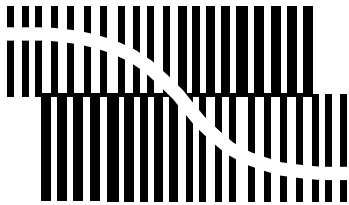

BITSTREAM CONVERSION

UDA1330ATS Low-cost stereo filter DAC

Product specification
Supersedes data of 2000 April 18

2001 Feb 02



Low-cost stereo filter DAC

UDA1330ATS

FEATURES

General

- Low power consumption
- Power supply voltage from 2.7 to 5.5 V
- Selectable control via L3 microcontroller interface or via static pin control
- System clock frequencies of 256f_s, 384f_s and 512f_s selectable via L3 interface or 256f_s and 384f_s via static pin control
- Supports sampling frequencies (f_s) from 8 to 55 kHz
- Integrated digital filter plus non inverting Digital-to-Analog Converter (DAC)
- No analog post filtering required for DAC
- Slave mode only applications
- Easy application
- Small package size (SSOP16)
- TTL tolerant input pads
- Pin and function compatible with the UDA1320ATS.

Multiple format input interface

- L3 mode: I²S-bus, MSB-justified or LSB-justified 16, 18 and 20 bits format compatible
- Static pin mode: I²S-bus and LSB-justified 16, 18 and 20 bits format compatible
- 1f_s input format data rate.

DAC digital sound processing

- Digital logarithmic volume control in L3 mode
- Digital de-emphasis for 32, 44.1 and 48 kHz sampling frequencies in L3 mode or 44.1 kHz sampling frequency in static pin mode
- Soft mute control both in static pin mode and L3 mode.

Advanced audio configuration

- Stereo line output (volume control in L3 mode)
- High linearity, wide dynamic range and low distortion.

ORDERING INFORMATION

TYPE NUMBER	PACKAGE		
	NAME	DESCRIPTION	VERSION
UDA1330ATS	SSOP16	plastic shrink small outline package; 16 leads; body width 4.4 mm	SOT369-1

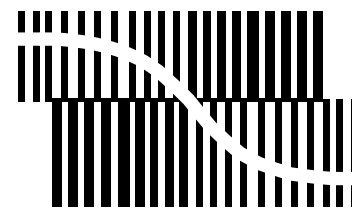

BITSTREAM CONVERSION

APPLICATIONS

- PC audio applications
- Car radio applications.

GENERAL DESCRIPTION

The UDA1330ATS is a single-chip stereo DAC employing bitstream conversion techniques.

The UDA1330ATS supports the I²S-bus data format with word lengths of up to 20 bits, the MSB-justified data format with word lengths of up to 20 bits and the LSB-justified serial data format with word lengths of 16, 18 and 20 bits.

The UDA1330ATS can be used in two modes: L3 mode or the static pin mode.

In the L3 mode, all digital sound processing features must be controlled via the L3 interface, including the selection of the system clock setting.

In the two static modes, the UDA1330ATS can be operated in the 256f_s and 384f_s system clock mode. Muting, de-emphasis for 44.1 kHz and four digital input formats (I²S-bus or LSB-justified 16, 18, and 20 bits) can be selected via static pins. The L3 interface cannot be used in this application mode, so volume control is not available in this mode.

Low-cost stereo filter DAC

UDA1330ATS

QUICK REFERENCE DATA

SYMBOL	PARAMETER	CONDITIONS	MIN.	TYP.	MAX.	UNIT
Supplies						
V_{DDA}	DAC analog supply voltage		2.7	5.0	5.5	V
V_{DDD}	digital supply voltage		2.7	5.0	5.5	V
I_{DDA}	DAC analog supply current	$V_{DDA} = 5.0$ V				
		operating	–	9.5	–	mA
		power-down	–	400	–	μ A
		$V_{DDA} = 3.3$ V				
	operating	–	7.0	–	mA	
	power-down	–	250	–	μ A	
I_{DDD}	digital supply current	$V_{DDD} = 5.0$ V	–	5.5	–	mA
		$V_{DDD} = 3.3$ V	–	3.0	–	mA
T_{amb}	ambient temperature		–40	–	+85	$^{\circ}$ C
Digital-to-analog converter ($V_{DDA} = V_{DDD} = 5.0$ V)						
$V_{o(rms)}$	output voltage (RMS value)	note 1	–	1.45	–	V
(THD + N)/S	total harmonic distortion-plus-noise to signal ratio	at 0 dB	–	–90	–85	dB
		at –60 dB; A-weighted	–	–40	–35	dB
S/N	signal-to-noise ratio	code = 0; A-weighted	–	100	95	dB
α_{CS}	channel separation		–	100	–	dB
Digital-to-analog converter ($V_{DDA} = V_{DDD} = 3.3$ V)						
$V_{o(rms)}$	output voltage (RMS value)	note 1	–	1.0	–	V
(THD + N)/S	total harmonic distortion-plus-noise to signal ratio	at 0 dB	–	–85	–	dB
		at –60 dB; A-weighted	–	–38	–	dB
S/N	signal-to-noise ratio	code = 0; A-weighted	–	100	–	dB
α_{CS}	channel separation		–	100	–	dB
Power dissipation						
P	power dissipation	playback mode				
		$V_{DDA} = V_{DDD} = 5.0$ V	–	75	–	mW
		$V_{DDA} = V_{DDD} = 3.3$ V	–	33	–	mW

Note

1. The output voltage scales linearly with the power supply voltage.

Low-cost stereo filter DAC

UDA1330ATS

BLOCK DIAGRAM

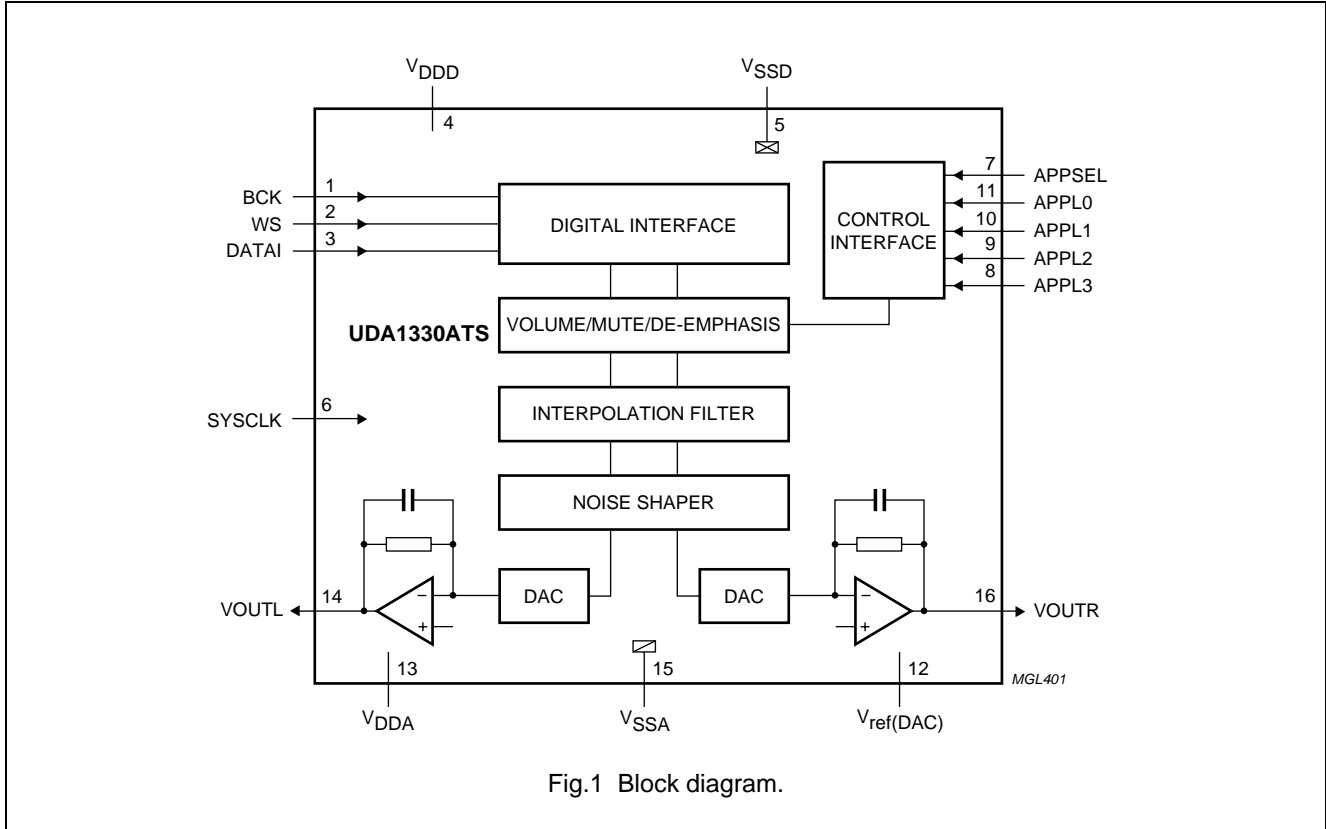

PINNING

SYMBOL	PIN	DESCRIPTION
BCK	1	bit clock input
WS	2	word select input
DATAI	3	data input
VDDD	4	digital supply voltage
VSSD	5	digital ground
SYSCLK	6	system clock input: 256f _s , 384f _s and 512f _s
APPSEL	7	application mode select input
APPL3	8	application input 3
APPL2	9	application input 2
APPL1	10	application input 1
APPL0	11	application input 0
Vref(DAC)	12	DAC reference voltage
VDDA	13	analog supply voltage for DAC
VOURL	14	left channel output
VSSA	15	analog ground
VOUTR	16	right channel output

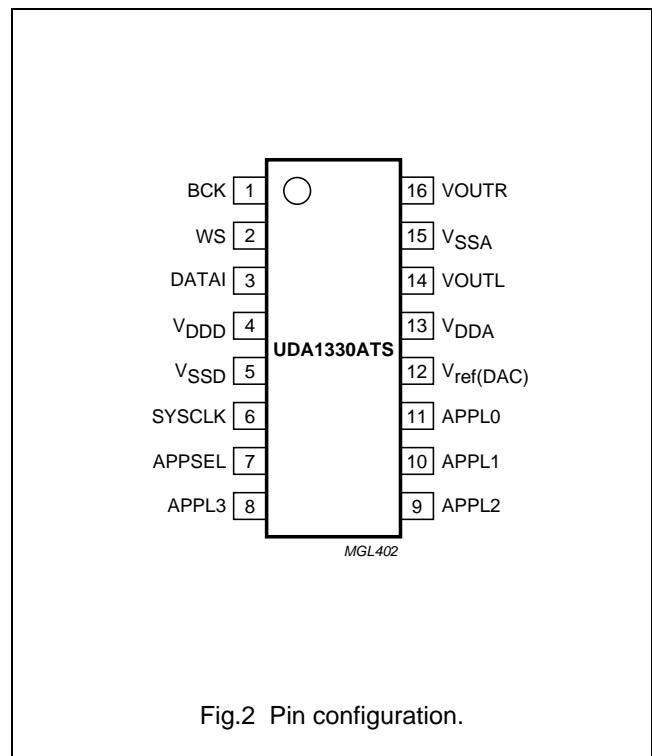

Low-cost stereo filter DAC

UDA1330ATS

FUNCTIONAL DESCRIPTION

System clock

The UDA1330ATS operates in slave mode only. Therefore, in all applications the system devices must provide the system clock. The system frequency (f_{sys}) is selectable and depends on the application mode. The options are: $256f_s$, $384f_s$ and $512f_s$ for the L3 mode and $256f_s$ or $384f_s$ for the static pin mode. The system clock must be locked in frequency to the digital interface input signals.

The UDA1330ATS supports sampling frequencies from 8 to 55 kHz.

Application modes

The application mode can be set with the three-level pin APPSEL (see Table 1):

- L3 mode
- Static pin mode with $f_{sys} = 384f_s$
- Static pin mode with $f_{sys} = 256f_s$.

Table 1 Selecting application mode and system clock frequency via pin APPSEL

VOLTAGE ON PIN APPSEL	MODE	f_{sys}
V_{SSD}	L3 mode	$256f_s$, $384f_s$ or $512f_s$
$0.5V_{DDD}$	static pin mode	$384f_s$
V_{DDD}		$256f_s$

The function of an application input pin (active HIGH) depends on the application mode (see Table 2).

Table 2 Functions of application input pins

PIN	FUNCTION	
	L3 MODE	STATIC PIN MODE
APPL0	TEST	MUTE
APPL1	L3CLOCK	DEEM
APPL2	L3MODE	SF0
APPL3	L3DATA	SF1

For example, in the static pin mode the output signal can be soft muted by setting pin APPL0 to HIGH. De-emphasis can be switched on for 44.1 kHz by setting pin APPL1 to HIGH; setting pin APPL1 to LOW will disable de-emphasis.

In the L3 mode, pin APPL0 must be set to LOW. It should be noted that when the L3 mode is used, an initialization must be performed when the IC is powered-up.

Multiple format input interface

DATA FORMATS

The digital interface of the UDA1330ATS supports multiple format inputs (see Fig.3).

Left and right data-channel words are time multiplexed.

The WS signal must have a 50% duty factor for all LSB-justified formats.

The BCK clock can be up to $64f_s$, or in other words the BCK frequency is 64 times the Word Select (WS) frequency or less: $f_{BCK} \leq 64 \times f_{WS}$.

Important: the WS edge MUST fall on the negative edge of the BCK at all times for proper operation of the digital interface.

The UDA1330ATS also accepts double speed data for double speed data monitoring purposes

L3 MODE

This mode supports the following input formats:

- I²S-bus format with data word length of up to 20 bits
- MSB-justified format with data word length up to 20 bits
- LSB-justified format with data word length of 16, 18 or 20 bits.

STATIC PIN MODE

This mode supports the following input formats:

- I²S-bus format with data word length of up to 20 bits
- LSB-justified format with data word length of 16, 18 or 20 bits.

These four formats are selectable via the static pin codes SF0 and SF1 (see Table 3).

Table 3 Input format selection using SF0 and SF1

FORMAT	SF0	SF1
I ² S-bus	0	0
LSB-justified 16 bits	0	1
LSB-justified 18 bits	1	0
LSB-justified 20 bits	1	1

Low-cost stereo filter DAC

UDA1330ATS

Interpolation filter (DAC)

The digital filter interpolates from $1f_s$ to $128f_s$ by cascading a recursive filter and an FIR filter (see Table 4).

Table 4 Interpolation filter characteristics

ITEM	CONDITION	VALUE (dB)
Pass-band ripple	0 to $0.45f_s$	± 0.1
Stop band	$>0.55f_s$	-50
Dynamic range	0 to $0.45f_s$	108

Noise shaper

The 3rd-order noise shaper operates at $128f_s$. It shifts in-band quantization noise to frequencies well above the audio band. This noise shaping technique enables high signal-to-noise ratios to be achieved. The noise shaper output is converted into an analog signal using a Filter Stream DAC (FSDAC).

Filter stream DAC

The FSDAC is a semi-digital reconstruction filter that converts the 1-bit data stream of the noise shaper to an analog output voltage. The filter coefficients are implemented as current sources and are summed at virtual ground of the output operational amplifier. In this way very high signal-to-noise performance and low clock jitter sensitivity is achieved. A post-filter is not needed due to the inherent filter function of the DAC. On-board amplifiers convert the FSDAC output current to an output voltage signal capable of driving a line output.

The output voltage of the FSDAC scales linearly with the power supply voltage.

Pin compatibility

In the L3 mode the UDA1330ATS can be used on boards that are designed for the UDA1320ATS.

Remark: It should be noted that the UDA1330ATS is designed for 5 V operation while the UDA1320ATS is designed for 3 V operation. This means that the UDA1330ATS can be used with the UDA1320ATS supply voltage range, but the UDA1320ATS can not be used with the 5 V supply voltage.

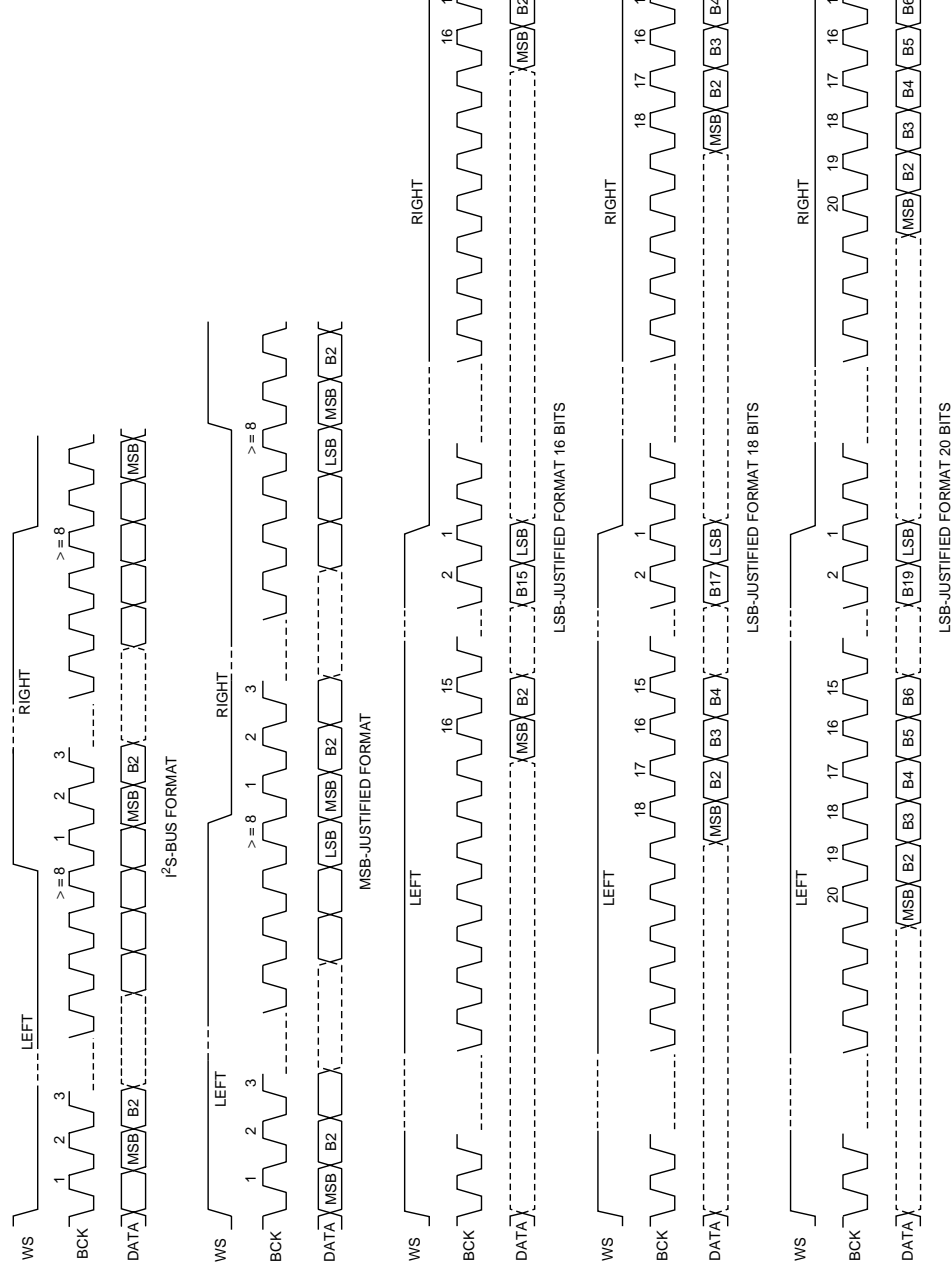

Fig.3 Digital interface input format data format.

Low-cost stereo filter DAC

UDA1330ATS

L3 INTERFACE

The following system and digital sound processing features can be controlled in the L3 mode of the UDA1330ATS:

- System clock frequency
- Data input format
- De-emphasis for 32, 44.1 and 48 kHz
- Volume
- Soft mute.

The exchange of data and control information between the microcontroller and the UDA1330ATS is accomplished through a serial interface comprising the following signals:

- L3DATA
- L3MODE
- L3CLOCK.

Information transfer through the microcontroller bus is organized in accordance with the L3 interface format, in which two different modes of operation can be distinguished: address mode and data transfer mode.

Address mode

The address mode (see Fig.4) is required to select a device communicating via the L3 interface and to define the destination registers for the data transfer mode.

Data bits 7 to 2 represent a 6-bit device address where bit 7 is the MSB. The address of the UDA1330ATS is 000101 (bit 7 to bit 2). If the UDA1330ATS receives a different address, it will deselect its microcontroller interface logic.

Data transfer mode

The selected address remains active during subsequent data transfers until the UDA1330ATS receives a new address command.

The fundamental timing of data transfers (see Fig.5) is essentially the same as the address mode. The maximum input clock frequency and data rate is $64f_s$.

Data transfer can only be in one direction, consisting of input to the UDA1330ATS to program sound processing and other functional features. All data transfers are by 8-bit bytes. Data will be stored in the UDA1330ATS after reception of a complete byte.

A multibyte transfer is illustrated in Fig.6.

Registers

The sound processing and other feature values are stored in independent registers. The first selection of the registers is achieved by the choice of data type that is transferred. This is performed in the address mode using bit 1 and bit 0 (see Table 5).

Table 5 Selection of data transfer

BIT 1	BIT 0	TRANSFER
0	0	data (volume, de-emphasis, mute)
0	1	not used
1	0	status (system clock frequency, data input format)
1	1	not used

The second selection is performed by the 2 MSBs of the data byte (bit 7 and bit 6). The other bits in the data byte (bit 5 to bit 0) represent the value that is placed in the selected registers.

The 'status' settings are given in Table 6 and the 'data' settings are given in Table 7.

Low-cost stereo filter DAC

UDA1330ATS

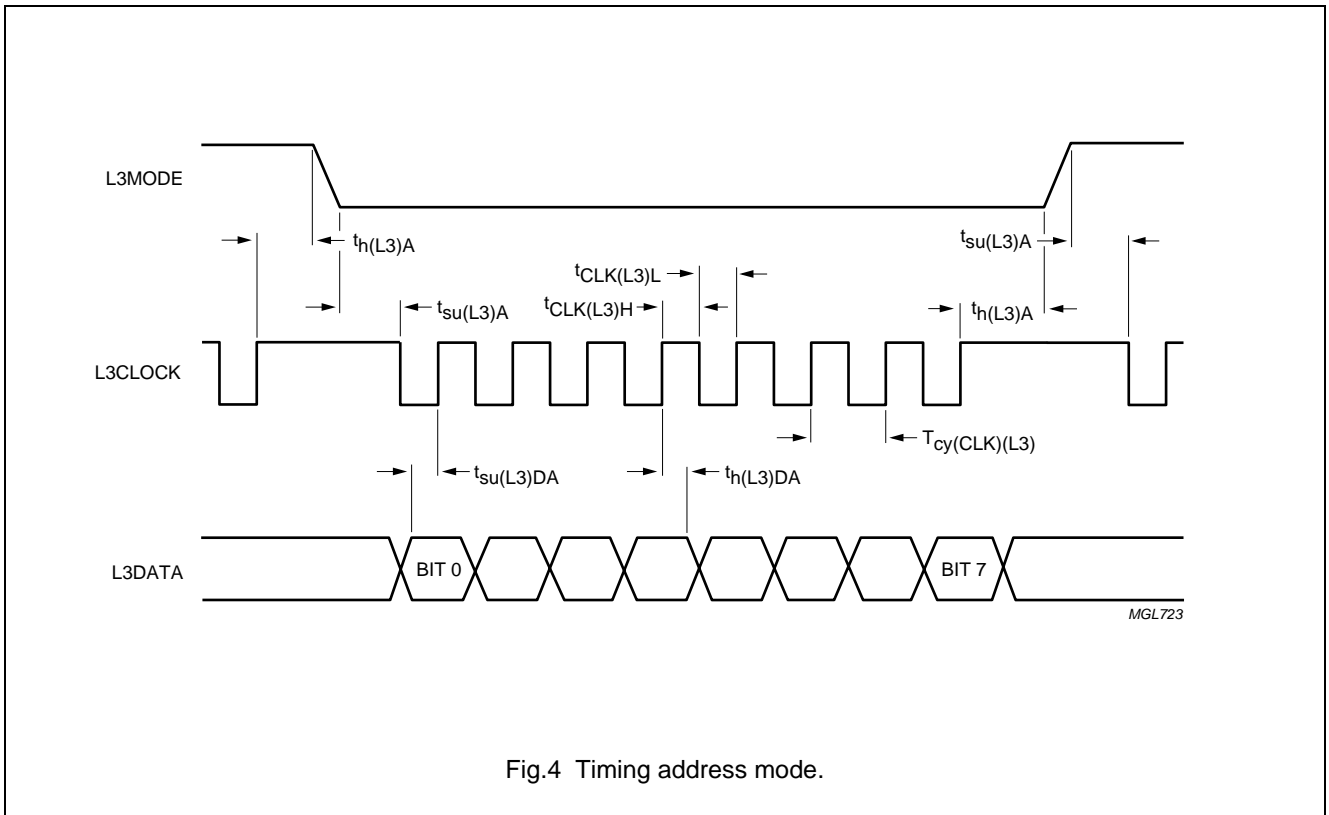

Fig.4 Timing address mode.

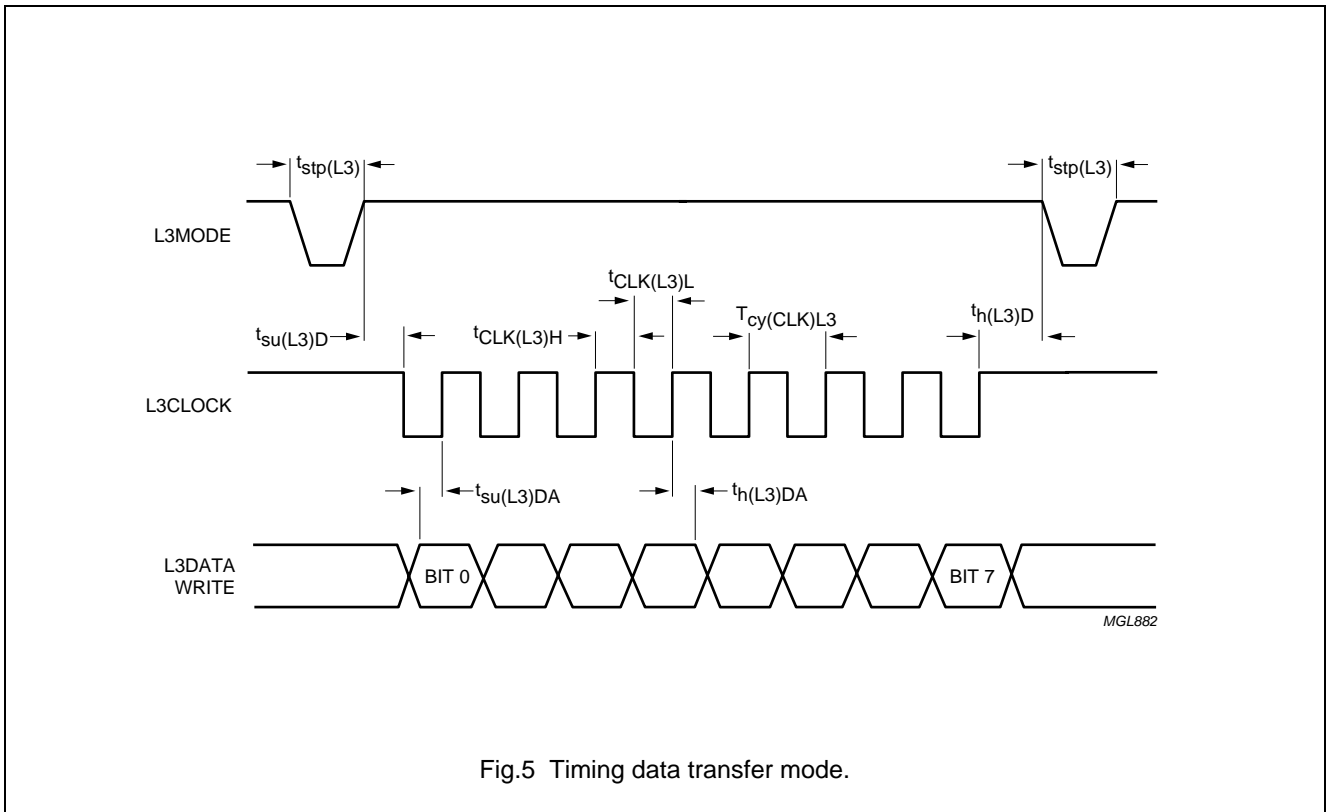

Fig.5 Timing data transfer mode.

Low-cost stereo filter DAC

UDA1330ATS

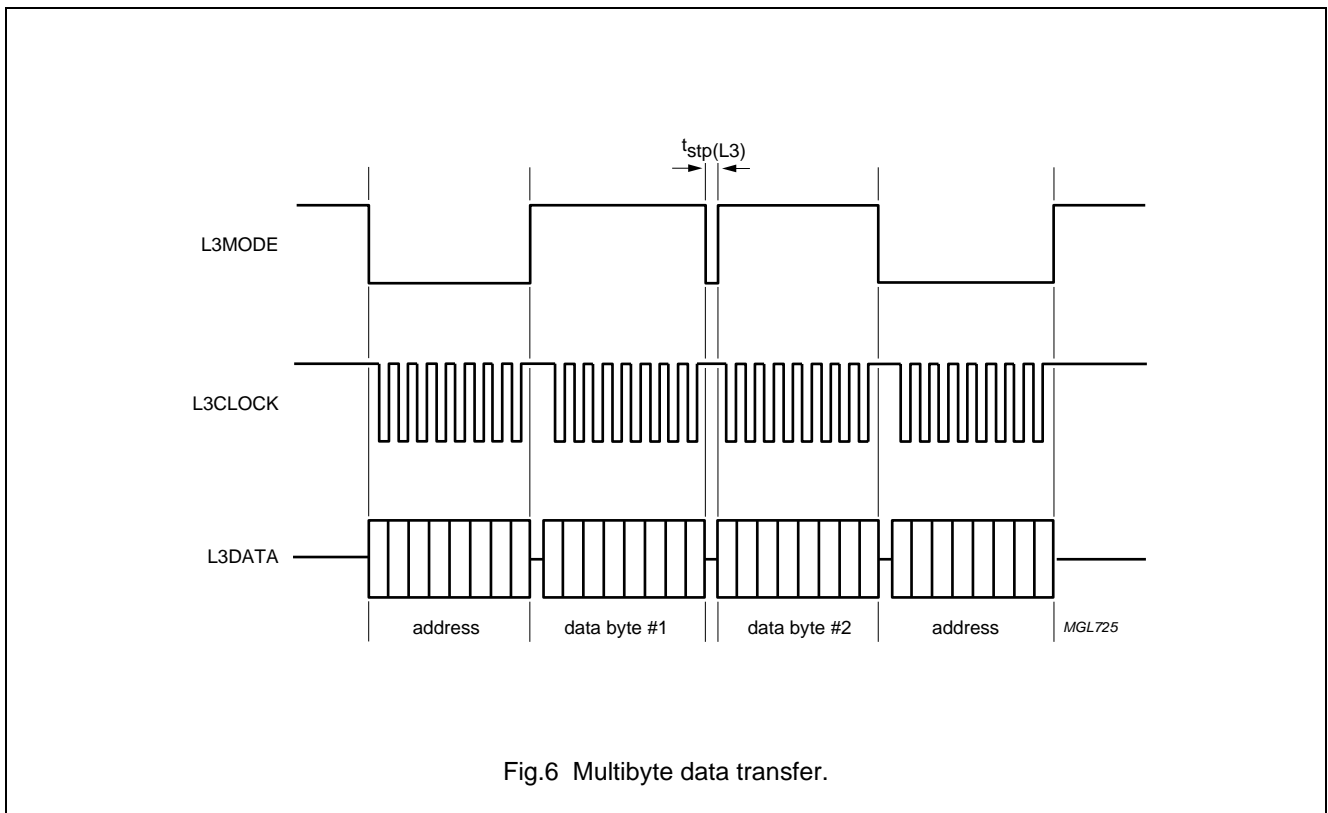

Fig.6 Multibyte data transfer.

Programming the features

When the data transfer of type 'status' is selected, the features for the system clock frequency and the data input format can be controlled.

Table 6 Data transfer of type 'status'

BIT 7	BIT 6	BIT 5	BIT 4	BIT 3	BIT 2	BIT 1	BIT 0	REGISTER SELECTED
0	0	SC1	SC0	IF2	IF1	IF0	0	SC = system clock frequency (2 bits); see Table 8 IF = data input format (3 bits); see Table 9
1	0	0	0	0	0	0	0	not used

When the data transfer of type 'data' is selected, the features for volume, de-emphasis and mute can be controlled.

Table 7 Data transfer of type 'data'

BIT 7	BIT 6	BIT 5	BIT 4	BIT 3	BIT 2	BIT 1	BIT 0	REGISTER SELECTED
0	0	VC5	VC4	VC3	VC2	VC1	VC0	VC = volume control (6 bits); see Table 11
0	1	0	0	0	0	0	0	not used
1	0	0	DE1	DE0	MT	0	0	DE = de-emphasis (2 bits); see Table 10 MT = mute (1 bit); see Table 12
1	1	0	0	0	0	0	1	default setting

Low-cost stereo filter DAC

UDA1330ATS

SYSTEM CLOCK FREQUENCY

The system clock frequency is a 2-bit value to select the external clock frequency.

Table 8 System clock settings

SC1	SC0	FUNCTION
0	0	512f _s
0	1	384f _s
1	0	256f _s
1	1	not used

DATA FORMAT

The data format is a 3-bit value to select the used data format.

Table 9 Data input format settings

IF2	IF1	IF0	FORMAT
0	0	0	I ² S-bus
0	0	1	LSB-justified 16 bits
0	1	0	LSB-justified 18 bits
0	1	1	LSB-justified 20 bits
1	0	0	MSB-justified
1	0	1	not used
1	1	0	not used
1	1	1	not used

DE-EMPHASIS

De-emphasis is a 2-bit value to enable the digital de-emphasis filter.

Table 10 De-emphasis settings

DE1	DE0	FUNCTION
0	0	no de-emphasis
0	1	de-emphasis, 32 kHz
1	0	de-emphasis, 44.1 kHz
1	1	de-emphasis, 48 kHz

VOLUME CONTROL

The volume control is a 6-bit value to program the volume attenuation from 0 to -60 dB and -∞ dB in steps of 1 dB.

Table 11 Volume settings

VC5	VC4	VC3	VC2	VC1	VC0	VOLUME (dB)
0	0	0	0	0	0	0
0	0	0	0	0	1	0
0	0	0	0	1	0	-1
0	0	0	0	1	1	-2
:	:	:	:	:	:	:
1	1	0	0	1	1	-51
1	1	0	1	0	0	
1	1	0	1	0	1	-52
1	1	0	1	1	0	
1	1	0	1	1	1	-54
1	1	1	0	0	0	
1	1	1	0	0	1	-57
1	1	1	0	1	1	
1	1	1	1	0	0	-60
1	1	1	1	0	1	
1	1	1	1	1	0	-∞
1	1	1	1	1	1	

MUTE

Mute is a 1-bit value to enable the digital mute.

Table 12 Mute setting

MT	FUNCTION
0	no muting
1	muting

Low-cost stereo filter DAC

UDA1330ATS

LIMITING VALUES

In accordance with the Absolute Maximum Rating System (IEC 60134).

SYMBOL	PARAMETER	CONDITIONS	MIN.	MAX.	UNIT
V _{DDD}	digital supply voltage	note 1	–	6.0	V
V _{DDA}	analog supply voltage	note 1	–	6.0	V
T _{xal(max)}	maximum crystal temperature		–	150	°C
T _{stg}	storage temperature		–65	+125	°C
T _{amb}	ambient temperature		–40	+85	°C
V _{es}	electrostatic handling voltage	note 2	–3000	+3000	V
		note 3	–250	+250	V
I _{sc(DAC)}	short-circuit current of DAC	note 4			
		output short-circuited to V _{SSA(DAC)}	–	450	mA
		output short-circuited to V _{DDA(DAC)}	–	300	mA

Notes

1. All supply connections must be made to the same power supply.
2. Equivalent to discharging a 100 pF capacitor via a 1.5 kΩ series resistor.
3. Equivalent to discharging a 200 pF capacitor via a 2.5 μH series inductor.
4. Short-circuit test at T_{amb} = 0 °C and V_{DDA} = 3 V. DAC operation after short-circuiting cannot be warranted.

HANDLING

Inputs and outputs are protected against electrostatic discharge in normal handling. However, to be totally safe, it is desirable to take normal precautions appropriate to handling MOS devices.

THERMAL CHARACTERISTICS

SYMBOL	PARAMETER	CONDITIONS	VALUE	UNIT
R _{th(j-a)}	thermal resistance from junction to ambient	in free air	190	K/W

QUALITY SPECIFICATION

In accordance with "SNW-FQ-611-E".

Low-cost stereo filter DAC

UDA1330ATS

DC CHARACTERISTICS

$V_{DD} = V_{DDA} = 5.0\text{ V}$; $T_{\text{amb}} = 25\text{ °C}$; $R_L = 5\text{ k}\Omega$; all voltages referenced to ground (pins V_{SSA} and V_{SSD}); unless otherwise specified.

SYMBOL	PARAMETER	CONDITIONS	MIN.	TYP.	MAX.	UNIT
Supplies						
V_{DDA}	DAC analog supply voltage	note 1	2.7	5.0	5.5	V
V_{DDD}	digital supply voltage	note 1	2.7	5.0	5.5	V
I_{DDA}	DAC analog supply current	$V_{DDA} = 5.0\text{ V}$ operating	–	9.5	–	mA
		$V_{DDA} = 5.0\text{ V}$ power-down	–	400	–	μA
		$V_{DDA} = 3.3\text{ V}$ operating	–	7.0	–	mA
		$V_{DDA} = 3.3\text{ V}$ power-down	–	250	–	μA
I_{DDD}	digital supply current	$V_{DDD} = 5.0\text{ V}$	–	5.5	–	mA
		$V_{DDD} = 3.3\text{ V}$	–	3.0	–	mA
Power dissipation						
P	power dissipation	playback mode $V_{DDA} = V_{DDD} = 5.0\text{ V}$ $V_{DDA} = V_{DDD} = 3.3\text{ V}$	–	75 33	–	mW mW
Digital inputs: pins BCK, WS, DATAI, SYSCLK, APPL0, APPL1, APPL2 and APPL3 (note 2)						
V_{IH}	HIGH-level input voltage	$V_{DDD} = 5.0\text{ V}$	2.2	–	–	V
		$V_{DDD} = 3.3\text{ V}$	1.45	–	–	V
V_{IL}	LOW-level input voltage	$V_{DDD} = 5.0\text{ V}$	–	–	0.8	V
		$V_{DDD} = 3.3\text{ V}$	–	–	0.5	V
$ I_{LI} $	input leakage current		–	–	1	μA
C_i	input capacitance		–	–	10	pF
Three-level input: APPSEL						
V_{IH}	HIGH-level input voltage		$0.9V_{DDD}$	–	$V_{DDD} + 0.5$	V
V_{IM}	MIDDLE-level input voltage		$0.4V_{DDD}$	–	$0.6V_{DDD}$	V
V_{IL}	LOW-level input voltage		–0.5	–	$+0.1V_{DDD}$	V

Low-cost stereo filter DAC

UDA1330ATS

SYMBOL	PARAMETER	CONDITIONS	MIN.	TYP.	MAX.	UNIT
DAC						
$V_{\text{ref(DAC)}}$	reference voltage	with respect to V_{SSA}	$0.45V_{\text{DDA}}$	$0.5V_{\text{DDA}}$	$0.55V_{\text{DDA}}$	V
$I_{\text{o(max)}}$	maximum output current	(THD + N)/S < 0.1%; $R_{\text{L}} = 5 \text{ k}\Omega$	–	0.36	–	mA
R_{o}	output resistance		–	0.15	2.0	Ω
R_{L}	load resistance		3	–	–	$\text{k}\Omega$
C_{L}	load capacitance	note 3	–	–	50	pF

Notes

- All supply connections must be made to the same external power supply unit.
- The digital input pads are TTL compatible at 5 V, but the pads are not 5 V tolerant in the voltage range between 2.7 and 4.5 V.
- When the DAC drives a capacitive load above 50 pF, a series resistance of 100 Ω must be used to prevent oscillations in the output operational amplifier.

AC CHARACTERISTICS

$f_{\text{i}} = 1 \text{ kHz}$; $T_{\text{amb}} = 25 \text{ }^\circ\text{C}$; $R_{\text{L}} = 5 \text{ k}\Omega$; all voltages referenced to ground (pins V_{SSA} and V_{SSD}); unless otherwise specified.

SYMBOL	PARAMETER	CONDITIONS	TYP.	MAX.	UNIT
Digital-to-analog converter ($V_{\text{DDA}} = V_{\text{DDD}} = 5.0 \text{ V}$)					
$V_{\text{o(rms)}}$	output voltage (RMS value)		1.45	–	V
ΔV_{o}	unbalance between channels		0.1	–	dB
(THD + N)/S	total harmonic distortion-plus-noise to signal ratio	at 0 dB	–90	–85	dB
		at –60 dB; A-weighted	–40	–35	dB
S/N	signal-to-noise ratio	code = 0; A-weighted	100	95	dB
α_{cs}	channel separation		100	–	dB
Digital-to-analog converter ($V_{\text{DDA}} = V_{\text{DDD}} = 3.3 \text{ V}$)					
$V_{\text{o(rms)}}$	output voltage (RMS value)		1.0	–	V
ΔV_{o}	unbalance between channels		0.1	–	dB
(THD + N)/S	total harmonic distortion-plus-noise to signal ratio	at 0 dB	–85	–	dB
		at –60 dB; A-weighted	–38	–	dB
S/N	signal-to-noise ratio	code = 0; A-weighted	100	–	dB
α_{cs}	channel separation		100	–	dB
PSRR	power supply ripple rejection	$f_{\text{ripple}} = 1 \text{ kHz}$; $V_{\text{ripple}} = 100 \text{ mV (p-p)}$	60	–	dB

Low-cost stereo filter DAC

UDA1330ATS

TIMING

$V_{DD} = V_{DDA} = 4.5$ to 5.5 V; $T_{amb} = -40$ to $+85$ °C; $R_L = 5$ k Ω ; all voltages referenced to ground (pins V_{SSA} and V_{SSD}); unless otherwise specified.

SYMBOL	PARAMETER	CONDITIONS	MIN.	TYP.	MAX.	UNIT
System clock (see Fig.7)						
T_{sys}	system clock cycle time	$f_{sys} = 256f_s$	71	88	488	ns
		$f_{sys} = 384f_s$	47	59	325	ns
		$f_{sys} = 512f_s$	36	44	244	ns
t_{CWL}	LOW-level system clock pulse width	$f_{sys} < 19.2$ MHz	$0.3T_{sys}$	–	$0.7T_{sys}$	ns
		$f_{sys} \geq 19.2$ MHz	$0.4T_{sys}$	–	$0.6T_{sys}$	ns
t_{CWH}	HIGH-level system clock pulse width	$f_{sys} < 19.2$ MHz	$0.3T_{sys}$	–	$0.7T_{sys}$	ns
		$f_{sys} \geq 19.2$ MHz	$0.4T_{sys}$	–	$0.6T_{sys}$	ns
Digital interface (see Fig.8)						
$T_{cy}(BCK)$	bit clock cycle time		300	–	–	ns
t_{BCKH}	bit clock HIGH time		100	–	–	ns
t_{BCKL}	bit clock LOW time		100	–	–	ns
t_r	rise time		–	–	20	ns
t_f	fall time		–	–	20	ns
$t_{su}(DATAI)$	data input set-up time		20	–	–	ns
$t_h(DATAI)$	data input hold time		0	–	–	ns
$t_{su}(WS)$	word select set-up time		20	–	–	ns
$t_h(WS)$	word select hold time		10	–	–	ns
Control interface L3 mode (see Figs 4 and 5)						
$T_{cy}(CLK)L3$	L3CLOCK cycle time		500	–	–	ns
$t_{CLK(L3)H}$	L3CLOCK HIGH time		250	–	–	ns
$t_{CLK(L3)L}$	L3CLOCK LOW time		250	–	–	ns
$t_{su}(L3)A$	L3MODE set-up time for address mode		190	–	–	ns
$t_h(L3)A$	L3MODE hold time for address mode		190	–	–	ns
$t_{su}(L3)D$	L3MODE set-up time for data transfer mode		190	–	–	ns
$t_h(L3)D$	L3MODE hold time for data transfer mode		190	–	–	ns
$t_{su}(L3)DA$	L3DATA set-up time for data transfer and address mode		190	–	–	ns
$t_h(L3)DA$	L3DATA hold time for data transfer and address mode		30	–	–	ns
$t_{stp}(L3)$	L3MODE stop time for data transfer mode		190	–	–	ns

Low-cost stereo filter DAC

UDA1330ATS

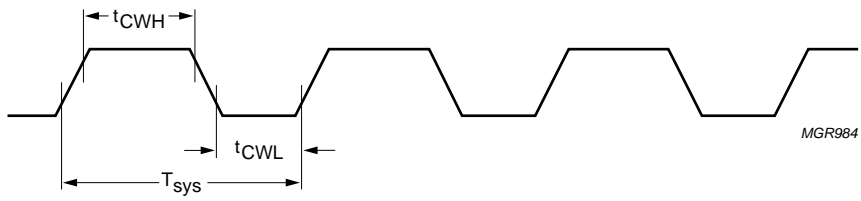

Fig.7 System clock timing.

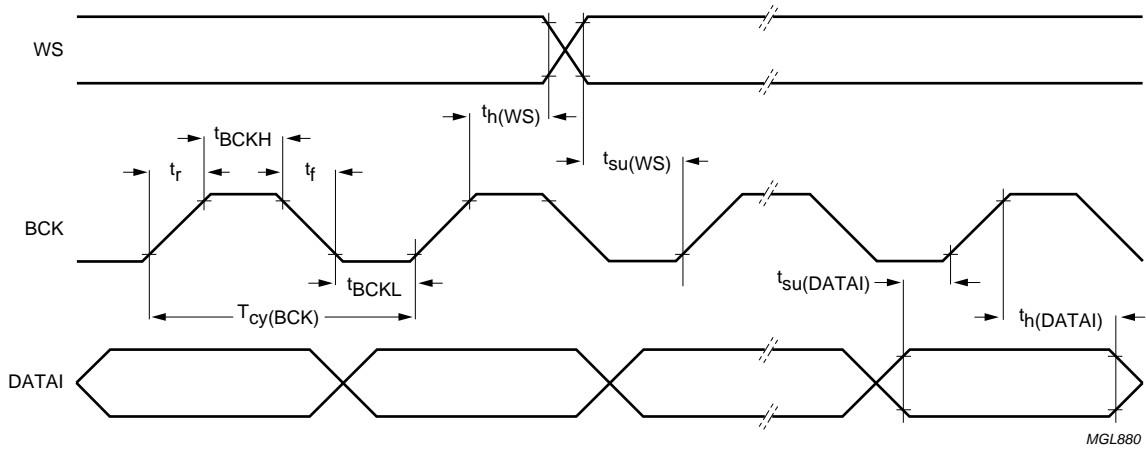

Fig.8 Serial interface timing.

Low-cost stereo filter DAC

UDA1330ATS

APPLICATION INFORMATION

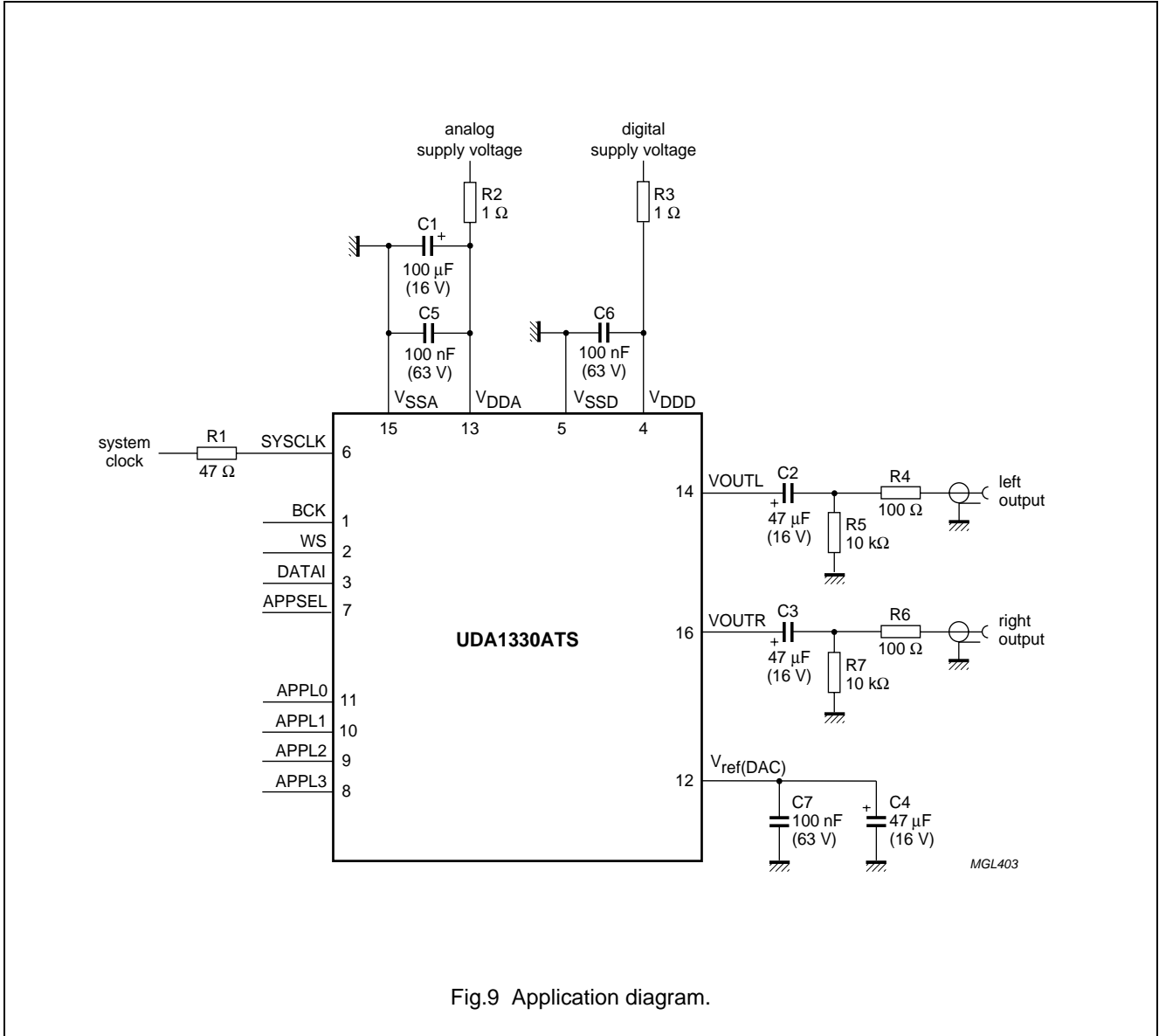

Fig.9 Application diagram.

Low-cost stereo filter DAC

UDA1330ATS

PACKAGE OUTLINE

SSOP16: plastic shrink small outline package; 16 leads; body width 4.4 mm

SOT369-1

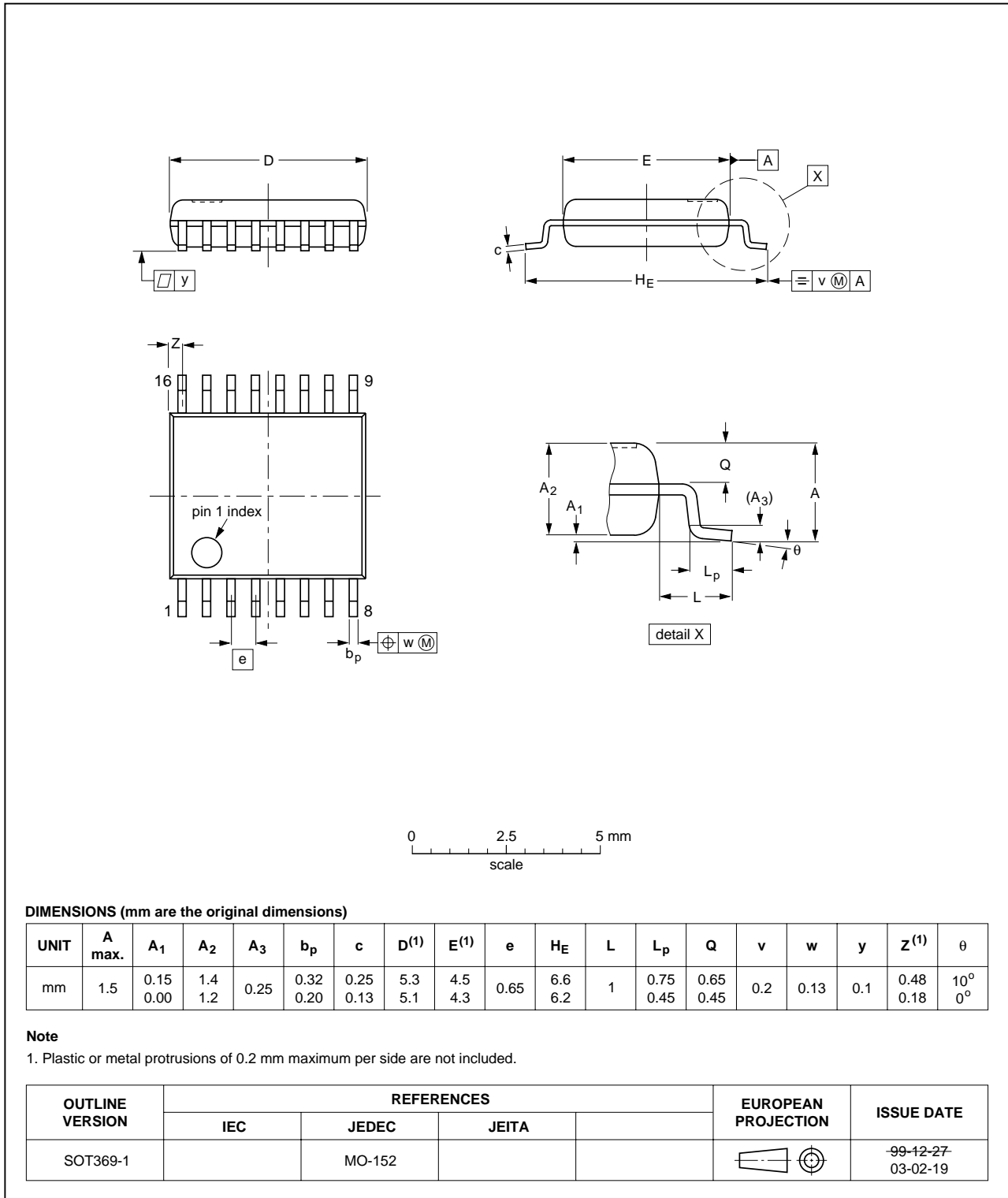

Low-cost stereo filter DAC

UDA1330ATS

SOLDERING

Introduction to soldering surface mount packages

This text gives a very brief insight to a complex technology. A more in-depth account of soldering ICs can be found in our *"Data Handbook IC26; Integrated Circuit Packages"* (document order number 9398 652 90011).

There is no soldering method that is ideal for all surface mount IC packages. Wave soldering is not always suitable for surface mount ICs, or for printed-circuit boards with high population densities. In these situations reflow soldering is often used.

Reflow soldering

Reflow soldering requires solder paste (a suspension of fine solder particles, flux and binding agent) to be applied to the printed-circuit board by screen printing, stencilling or pressure-syringe dispensing before package placement.

Several methods exist for reflowing; for example, infrared/convection heating in a conveyor type oven. Throughput times (preheating, soldering and cooling) vary between 100 and 200 seconds depending on heating method.

Typical reflow peak temperatures range from 215 to 250 °C. The top-surface temperature of the packages should preferably be kept below 230 °C.

Wave soldering

Conventional single wave soldering is not recommended for surface mount devices (SMDs) or printed-circuit boards with a high component density, as solder bridging and non-wetting can present major problems.

To overcome these problems the double-wave soldering method was specifically developed.

If wave soldering is used the following conditions must be observed for optimal results:

- Use a double-wave soldering method comprising a turbulent wave with high upward pressure followed by a smooth laminar wave.
- For packages with leads on two sides and a pitch (e):
 - larger than or equal to 1.27 mm, the footprint longitudinal axis is **preferred** to be parallel to the transport direction of the printed-circuit board;
 - smaller than 1.27 mm, the footprint longitudinal axis **must** be parallel to the transport direction of the printed-circuit board.

The footprint must incorporate solder thieves at the downstream end.

- For packages with leads on four sides, the footprint must be placed at a 45° angle to the transport direction of the printed-circuit board. The footprint must incorporate solder thieves downstream and at the side corners.

During placement and before soldering, the package must be fixed with a droplet of adhesive. The adhesive can be applied by screen printing, pin transfer or syringe dispensing. The package can be soldered after the adhesive is cured.

Typical dwell time is 4 seconds at 250 °C.

A mildly-activated flux will eliminate the need for removal of corrosive residues in most applications.

Manual soldering

Fix the component by first soldering two diagonally-opposite end leads. Use a low voltage (24 V or less) soldering iron applied to the flat part of the lead. Contact time must be limited to 10 seconds at up to 300 °C.

When using a dedicated tool, all other leads can be soldered in one operation within 2 to 5 seconds between 270 and 320 °C.

Low-cost stereo filter DAC

UDA1330ATS

Suitability of surface mount IC packages for wave and reflow soldering methods

PACKAGE	SOLDERING METHOD	
	WAVE	REFLOW ⁽¹⁾
BGA, LFBGA, SQFP, TFBGA	not suitable	suitable
HBCC, HLQFP, HSQFP, HSOP, HTQFP, HTSSOP, SMS	not suitable ⁽²⁾	suitable
PLCC ⁽³⁾ , SO, SOJ	suitable	suitable
LQFP, QFP, TQFP	not recommended ⁽³⁾⁽⁴⁾	suitable
SSOP, TSSOP, VSO	not recommended ⁽⁵⁾	suitable

Notes

1. All surface mount (SMD) packages are moisture sensitive. Depending upon the moisture content, the maximum temperature (with respect to time) and body size of the package, there is a risk that internal or external package cracks may occur due to vaporization of the moisture in them (the so called popcorn effect). For details, refer to the Drypack information in the *"Data Handbook IC26; Integrated Circuit Packages; Section: Packing Methods"*.
2. These packages are not suitable for wave soldering as a solder joint between the printed-circuit board and heatsink (at bottom version) can not be achieved, and as solder may stick to the heatsink (on top version).
3. If wave soldering is considered, then the package must be placed at a 45° angle to the solder wave direction. The package footprint must incorporate solder thieves downstream and at the side corners.
4. Wave soldering is only suitable for LQFP, TQFP and QFP packages with a pitch (e) equal to or larger than 0.8 mm; it is definitely not suitable for packages with a pitch (e) equal to or smaller than 0.65 mm.
5. Wave soldering is only suitable for SSOP and TSSOP packages with a pitch (e) equal to or larger than 0.65 mm; it is definitely not suitable for packages with a pitch (e) equal to or smaller than 0.5 mm.

Low-cost stereo filter DAC

UDA1330ATS

DATA SHEET STATUS

DOCUMENT STATUS ⁽¹⁾	PRODUCT STATUS ⁽²⁾	DEFINITION
Objective data sheet	Development	This document contains data from the objective specification for product development.
Preliminary data sheet	Qualification	This document contains data from the preliminary specification.
Product data sheet	Production	This document contains the product specification.

Notes

1. Please consult the most recently issued document before initiating or completing a design.
2. The product status of device(s) described in this document may have changed since this document was published and may differ in case of multiple devices. The latest product status information is available on the Internet at URL <http://www.nxp.com>.

DISCLAIMERS

Limited warranty and liability — Information in this document is believed to be accurate and reliable. However, NXP Semiconductors does not give any representations or warranties, expressed or implied, as to the accuracy or completeness of such information and shall have no liability for the consequences of use of such information.

In no event shall NXP Semiconductors be liable for any indirect, incidental, punitive, special or consequential damages (including - without limitation - lost profits, lost savings, business interruption, costs related to the removal or replacement of any products or rework charges) whether or not such damages are based on tort (including negligence), warranty, breach of contract or any other legal theory.

Notwithstanding any damages that customer might incur for any reason whatsoever, NXP Semiconductors' aggregate and cumulative liability towards customer for the products described herein shall be limited in accordance with the *Terms and conditions of commercial sale* of NXP Semiconductors.

Right to make changes — NXP Semiconductors reserves the right to make changes to information published in this document, including without limitation specifications and product descriptions, at any time and without notice. This document supersedes and replaces all information supplied prior to the publication hereof.

Suitability for use — NXP Semiconductors products are not designed, authorized or warranted to be suitable for use in life support, life-critical or safety-critical systems or equipment, nor in applications where failure or malfunction of an NXP Semiconductors product can reasonably be expected to result in personal injury, death or severe

property or environmental damage. NXP Semiconductors accepts no liability for inclusion and/or use of NXP Semiconductors products in such equipment or applications and therefore such inclusion and/or use is at the customer's own risk.

Applications — Applications that are described herein for any of these products are for illustrative purposes only. NXP Semiconductors makes no representation or warranty that such applications will be suitable for the specified use without further testing or modification.

Customers are responsible for the design and operation of their applications and products using NXP Semiconductors products, and NXP Semiconductors accepts no liability for any assistance with applications or customer product design. It is customer's sole responsibility to determine whether the NXP Semiconductors product is suitable and fit for the customer's applications and products planned, as well as for the planned application and use of customer's third party customer(s). Customers should provide appropriate design and operating safeguards to minimize the risks associated with their applications and products.

NXP Semiconductors does not accept any liability related to any default, damage, costs or problem which is based on any weakness or default in the customer's applications or products, or the application or use by customer's third party customer(s). Customer is responsible for doing all necessary testing for the customer's applications and products using NXP Semiconductors products in order to avoid a default of the applications and the products or of the application or use by customer's third party customer(s). NXP does not accept any liability in this respect.

Low-cost stereo filter DAC

UDA1330ATS

Limiting values — Stress above one or more limiting values (as defined in the Absolute Maximum Ratings System of IEC 60134) will cause permanent damage to the device. Limiting values are stress ratings only and (proper) operation of the device at these or any other conditions above those given in the Recommended operating conditions section (if present) or the Characteristics sections of this document is not warranted. Constant or repeated exposure to limiting values will permanently and irreversibly affect the quality and reliability of the device.

Terms and conditions of commercial sale — NXP Semiconductors products are sold subject to the general terms and conditions of commercial sale, as published at <http://www.nxp.com/profile/terms>, unless otherwise agreed in a valid written individual agreement. In case an individual agreement is concluded only the terms and conditions of the respective agreement shall apply. NXP Semiconductors hereby expressly objects to applying the customer's general terms and conditions with regard to the purchase of NXP Semiconductors products by customer.

No offer to sell or license — Nothing in this document may be interpreted or construed as an offer to sell products that is open for acceptance or the grant, conveyance or implication of any license under any copyrights, patents or other industrial or intellectual property rights.

Export control — This document as well as the item(s) described herein may be subject to export control regulations. Export might require a prior authorization from national authorities.

Quick reference data — The Quick reference data is an extract of the product data given in the Limiting values and Characteristics sections of this document, and as such is not complete, exhaustive or legally binding.

Non-automotive qualified products — Unless this data sheet expressly states that this specific NXP Semiconductors product is automotive qualified, the product is not suitable for automotive use. It is neither qualified nor tested in accordance with automotive testing or application requirements. NXP Semiconductors accepts no liability for inclusion and/or use of non-automotive qualified products in automotive equipment or applications.

In the event that customer uses the product for design-in and use in automotive applications to automotive specifications and standards, customer (a) shall use the product without NXP Semiconductors' warranty of the product for such automotive applications, use and specifications, and (b) whenever customer uses the product for automotive applications beyond NXP Semiconductors' specifications such use shall be solely at customer's own risk, and (c) customer fully indemnifies NXP Semiconductors for any liability, damages or failed product claims resulting from customer design and use of the product for automotive applications beyond NXP Semiconductors' standard warranty and NXP Semiconductors' product specifications.

NXP Semiconductors

provides High Performance Mixed Signal and Standard Product solutions that leverage its leading RF, Analog, Power Management, Interface, Security and Digital Processing expertise

Customer notification

This data sheet was changed to reflect the new company name NXP Semiconductors, including new legal definitions and disclaimers. No changes were made to the technical content, except for package outline drawings which were updated to the latest version.

Contact information

For additional information please visit: <http://www.nxp.com>

For sales offices addresses send e-mail to: salesaddresses@nxp.com

© NXP B.V. 2010

All rights are reserved. Reproduction in whole or in part is prohibited without the prior written consent of the copyright owner.

The information presented in this document does not form part of any quotation or contract, is believed to be accurate and reliable and may be changed without notice. No liability will be accepted by the publisher for any consequence of its use. Publication thereof does not convey nor imply any license under patent- or other industrial or intellectual property rights.

Printed in The Netherlands

753503/05/pp23

Date of release: 2001 Feb 02

Document order number: 9397 750 07939

Looking for pricing, stock, or lifecycle information?

Click below to explore more details on WIN SOURCE:

- ⊖ [View UDA1330ATS/N2 on WIN SOURCE](#)
- ⊖ [NXP / Nexperia Information](#)

Optimize Your Supply Chain with WIN SOURCE Solutions

- ✓ Global Sourcing Solution
- ✓ Obsolete Management
- ✓ Cost Control Management
- ✓ Shortage Management
- ✓ Alternative Solution
- ✓ Excess Inventory Management