



THE DATASHEET OF UCLAMP3311T.TCT



The μ Clamp[®] series of Transient Voltage Suppressors (TVS) are designed to replace multilayer varistors (MLVs) in portable applications such as cell phones, notebook computers, and PDAs. They offer superior electrical characteristics such as lower clamping voltage and no device degradation when compared to MLVs. They are designed to protect sensitive semiconductor components from damage or upset due to electrostatic discharge (ESD), lightning, electrical fast transients (EFT), and cable discharge events (CDE).

The μ Clamp[®]3311T is constructed using Semtech's proprietary EPD process technology. The EPD process provides low standoff voltages with significant reductions in leakage currents and capacitance over silicon-avalanche diode processes. They feature a true operating voltage of 3.3 volts for superior protection when compared to traditional pn junction devices.

The μ Clamp3311T is in a 2-pin SLP1006P2T package. It measures 1.0 x 0.6 x 0.4mm. The leads are spaced at a pitch of 0.65mm and are finished with lead-free NiPdAu. Each device will protect one line operating at 3.3 volts. It gives the designer the flexibility to protect single lines in applications where arrays are not practical. They may be used to meet the ESD immunity requirements of IEC 61000-4-2. The combination of small size and high ESD surge capability makes them ideal for use in portable applications such as cellular phones, digital cameras, and MP3 players.

- ◆ Transient protection for data lines to **IEC 61000-4-2 (ESD) $\pm 30\text{kV}$ (air), $\pm 30\text{kV}$ (contact) IEC 61000-4-4 (EFT) 40A (tp = 5/50ns) Cable Discharge Event (CDE)**
- ◆ Ultra-small package (1.0 x 0.6 x 0.4mm)
- ◆ Protects one data line
- ◆ Low reverse current: 10nA typical (VR=3.3V)
- ◆ Working voltage: 3.3V
- ◆ Low leakage current
- ◆ Solid-state silicon-avalanche technology

- ◆ SLP1006P2T package
- ◆ Pb-Free, Halogen Free, RoHS/WEEE Compliant
- ◆ Nominal Dimensions: 1.0 x 0.6 x 0.4 mm
- ◆ Lead Finish: NiPdAu
- ◆ Molding compound flammability rating: UL 94V-0
- ◆ Marking : Marking code
- ◆ Packaging : Tape and Reel

- ◆ Cellular Handsets & Accessories
- ◆ Portable Instrumentation
- ◆ Keypads, Side Keys, LCD Displays
- ◆ Notebooks & Desktop Computers
- ◆ MP3 Players

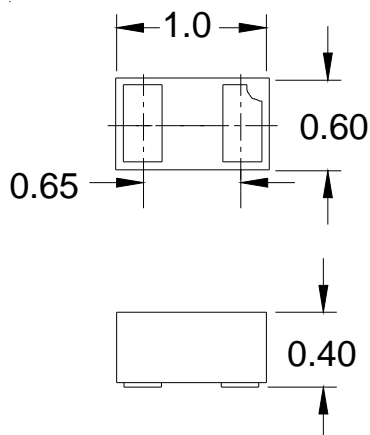

Nominal Dimensions (mm)

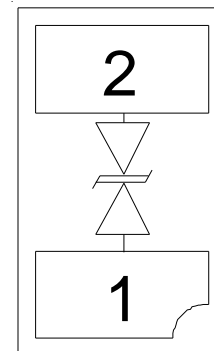

SLP1006P2T (Bottom View)

Rating	Symbol	Value	Units
Peak Pulse Power (tp = 8/20μs)	P_{pk}	40	Watts
Maximum Peak Pulse Current (tp = 8/20μs)	I_{pp}	5	Amps
ESD per IEC 61000-4-2 (Air) ¹ ESD per IEC 61000-4-2 (Contact) ¹	V_{ESD}	+/- 30 +/- 30	kV
Operating Temperature	T_J	-40 to +85	°C
Storage Temperature	T_{STG}	-55 to +150	°C

Parameter	Symbol	Conditions	Minimum	Typical	Maximum	Units
Reverse Stand-Off Voltage	V_{RWM}				3.3	V
Punch-Through Voltage	V_{PT}	$I_{PT} = 2\mu A$	3.5	3.9	4.3	V
Snap-Back Voltage	V_{SB}	$I_{SB} = 50mA$	2.8			V
Reverse Leakage Current	I_R	$V_{RWM} = 3.3V$		0.01	0.05	μA
Clamping Voltage	V_C	$I_{pp} = 1A, tp = 8/20\mu s$			6.5	V
Clamping Voltage	V_C	$I_{pp} = 5A, tp = 8/20\mu s$			8	V
ESD Clamping Voltage ²	V_C	$I_{pp} = 4A,$ $t_{lp} = 0.2/100ns$		5.6		V
ESD Clamping Voltage ²	V_C	$I_{pp} = 16A,$ $t_{lp} = 0.2/100ns$		8.6		V
Dynamic Resistance ^{2, 3}	R_{DYN}	$t_{lp} = 0.2 / 100ns$		0.25		Ohms
Junction Capacitance	C_j	I/O pin to Gnd $V_R = 0V, f = 1MHz$		5	7	pF

Notes

- 1)ESD gun return path connected to ESD ground plane.
- 2)Transmission Line Pulse Test (TLP) Settings: $t_p = 100ns$, $t_r = 0.2ns$, I_{TLP} and V_{TLP} averaging window: $t_1 = 70ns$ to $t_2 = 90ns$.
- 3) Dynamic resistance calculated from $I_{pp} = 4A$ to $I_{pp} = 16A$

Non-Repetitive Peak Pulse Power vs. Pulse Time

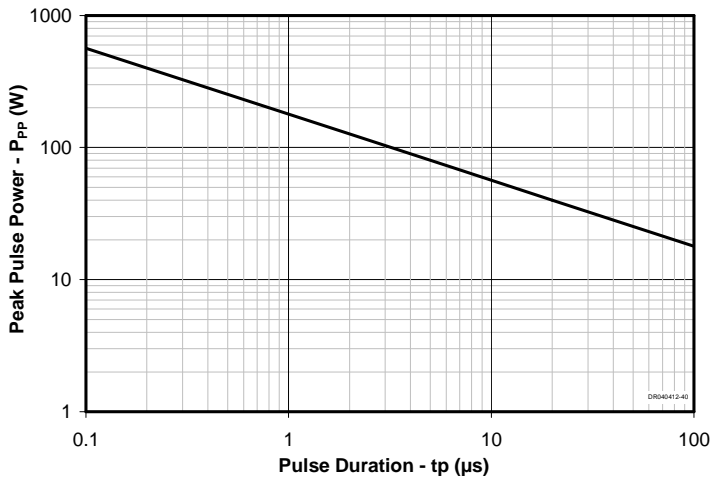

Clamping Voltage vs. Peak Pulse Current

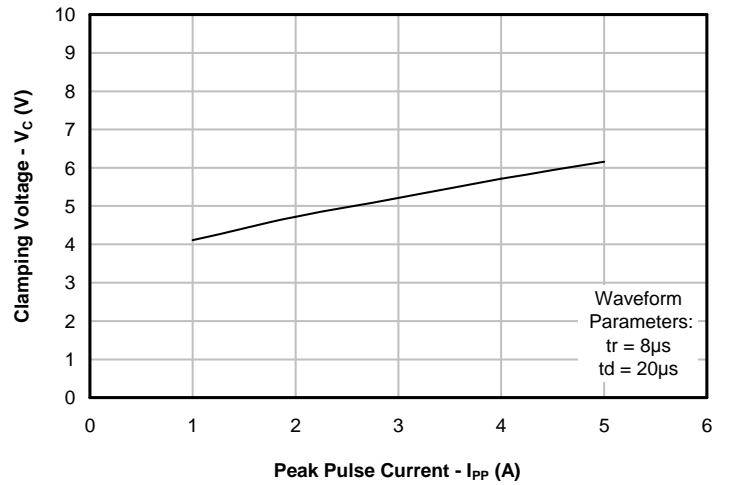

Normalized Capacitance vs. Reverse Voltage

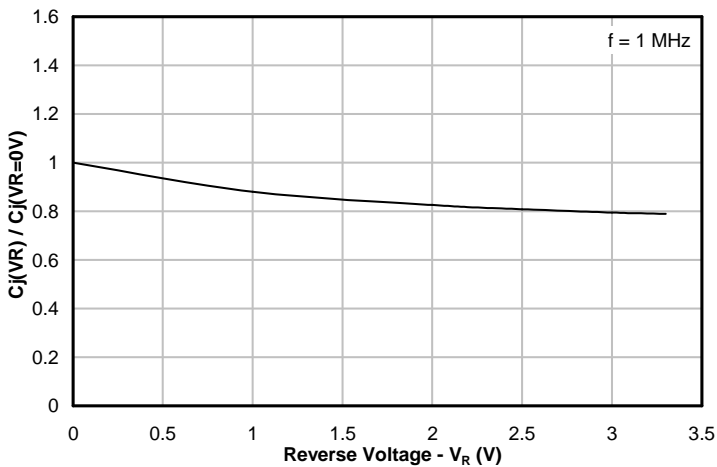

TLP Characteristic

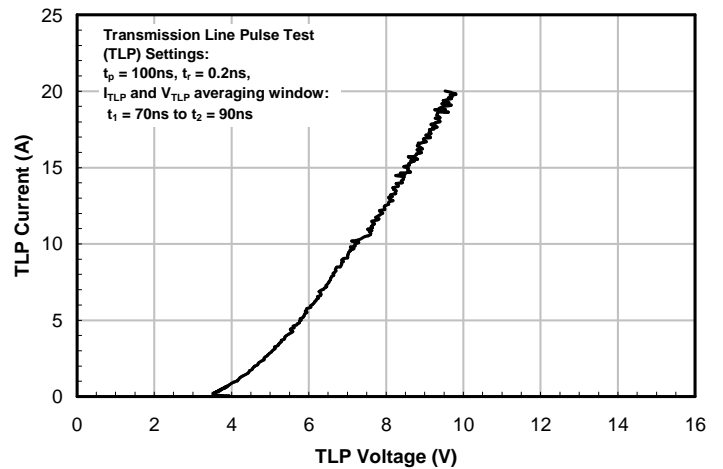

ESD Clamping (+8kV Contact per IEC 61000-4-2)

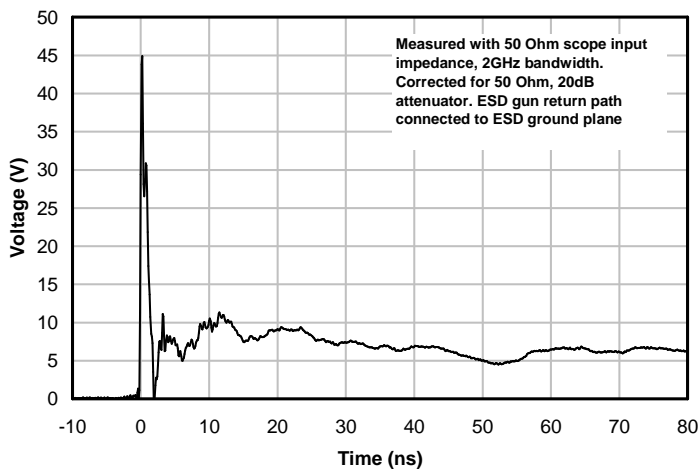

ESD Clamping (-8kV Contact per IEC 61000-4-2)

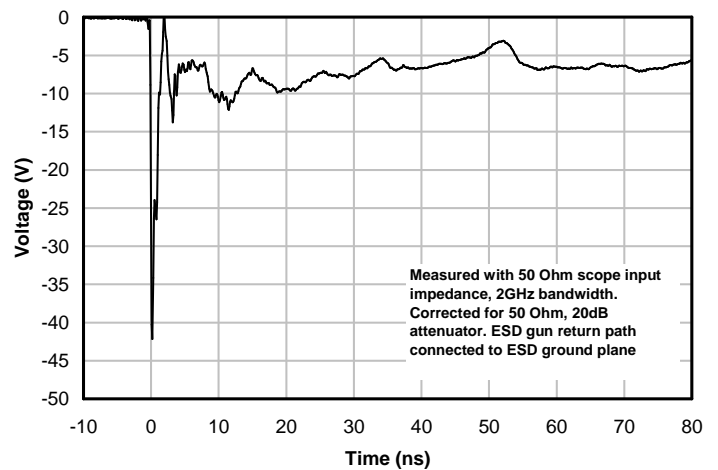

Typical Insertion Loss (S21)

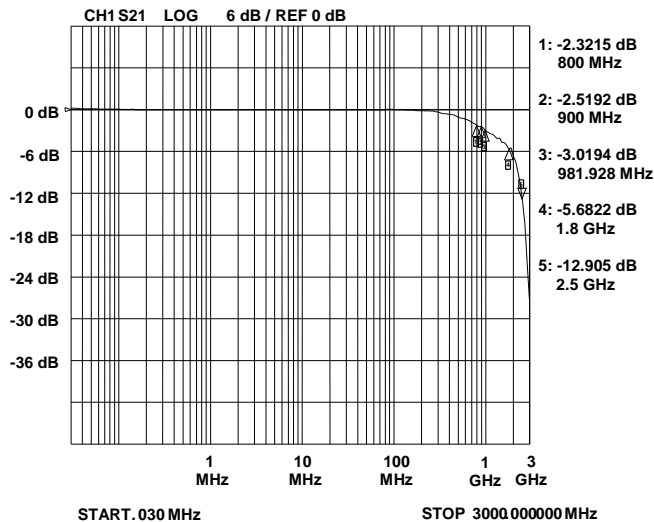

Device Connection Options

The μ Clamp3311T is designed to protect one data line operating up to 3.3 volts. It will present a high impedance to the protected line up to 3.3 volts. It will “turn on” when the line voltage exceeds 3.5 volts. The device is bidirectional and may be used on lines where the signal polarity is above and below ground. These devices are not recommended for use on dc power supply lines due to their snap-back voltage characteristic.

Circuit Board Layout Recommendations for Suppression of ESD.

Good circuit board layout is critical for the suppression of ESD induced transients. The following guidelines are recommended:

- Place the TVS near the input terminals or connectors to restrict transient coupling.
- Minimize the path length between the TVS and the protected line.
- Minimize all conductive loops including power and ground loops.
- The ESD transient return path to ground should be kept as short as possible.
- Never run critical signals near board edges.
- Use ground planes whenever possible.

Device Schematic & Pin Configuration

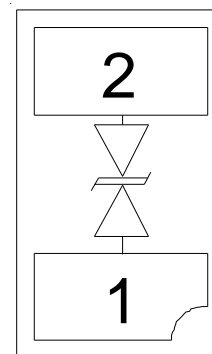

Semtech Low Voltage TVS

Conventional TVS diodes are silicon avalanche, p-n junction devices designed to operate at voltages as low as 5 volts. However, many of today's semiconductor devices operate at voltages below 5 volts, and thus require lower voltage protection devices. Unfortunately, for operating voltages below 5 volts, conventional TVS diode technology becomes impractical. This is due to the adverse effects of high leakage current and high capacitance caused by the high impurity concentrations that are needed to lower the device voltage below 5 volts. Semtech's proprietary low voltage EPD device technology was developed to provide protection for today's circuits operating at voltages below 5 volts. Unlike conventional TVS diodes, the EPD device utilizes a complex four layer (n-p-p-n) structure. The construction of these devices results in very low operating voltage without the adverse effects mentioned above.

Device Operation

Since the EPD TVS devices use a 4-layer structure, they exhibit a slightly different IV characteristic curve when compared to conventional devices. Figure 1 compares the IV characteristic curves of a low voltage TVS with a working voltage (V_{RWM}) of 3.3 volts to a conventional device with a working voltage of 5 volts. During normal operation, each device represents a high-impedance to the circuit up to its working voltage. During an ESD event, they will begin to conduct and will enter a low impedance state. For the 3.3 volt device, this happens when the punch-through voltage (V_{PT}) is exceeded. Unlike a conventional 5 volt device, the low voltage TVS will exhibit a slight negative resistance characteristic as it conducts current. This characteristic aids in lowering the clamping voltage of the device. However, the device can latch up if a DC bias voltage is present. The reason being that in order for the device to turn off, the voltage must fall below the snap-back voltage (V_{SB}). This value is normally a minimum of 2.8 volts. If the device is biased above the 2.8 volts, it will never fall below the snap-back voltage and will therefore stay in a conducting state.

Low Voltage TVS

- **Working Voltage (V_{RWM}):** Maximum rated operating voltage at which the device will appear as a high impedance to the protected circuit.
- **Punch-Through Voltage (V_{PT}):** Minimum rated voltage at which the device will become a low impedance (i.e. Minimum Turn-On Voltage). When V_{PT} is exceeded, the device will conduct.
- **Snap-Back Voltage (V_{SB}):** Minimum rated voltage when the device is in a conducting state measured at $I_{SB} = 50mA$. This voltage is less than the working voltage. The voltage must fall below V_{SB} for the device to turn off.
- **Clamping Voltage (V_C):** Maximum voltage drop across the device at a defined peak pulse current (I_{pp}). This is the voltage seen by the protected circuit during a transient event.

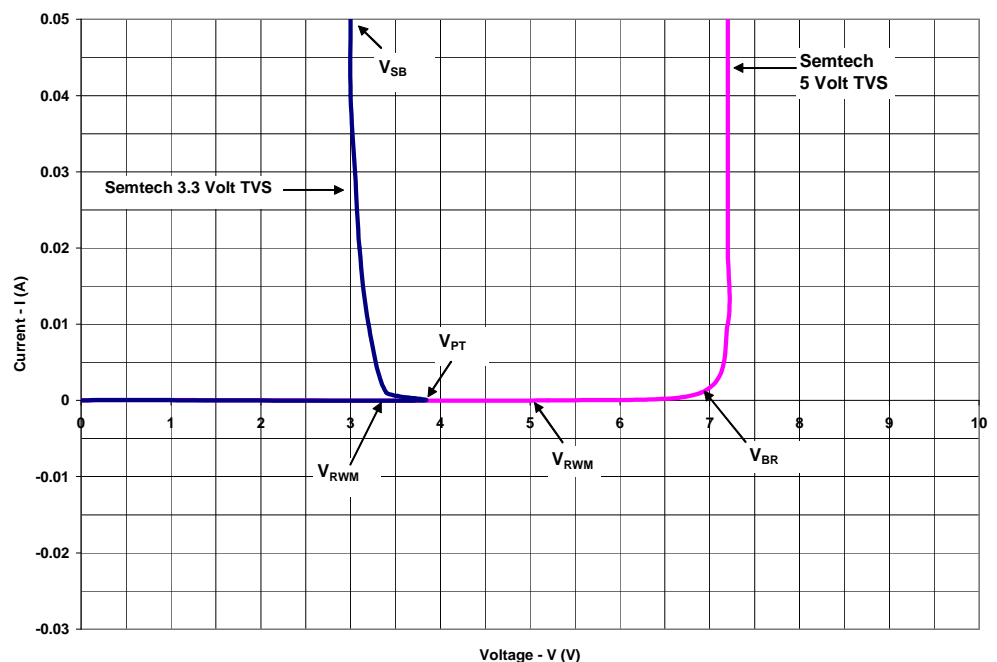
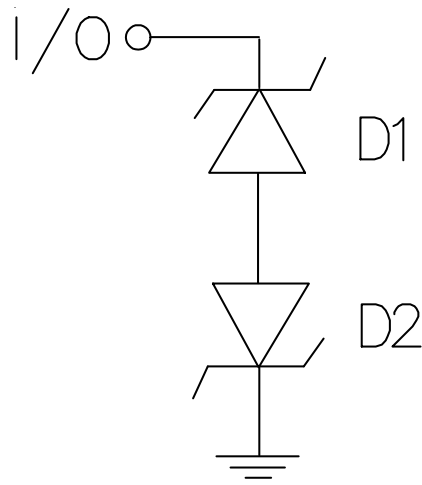
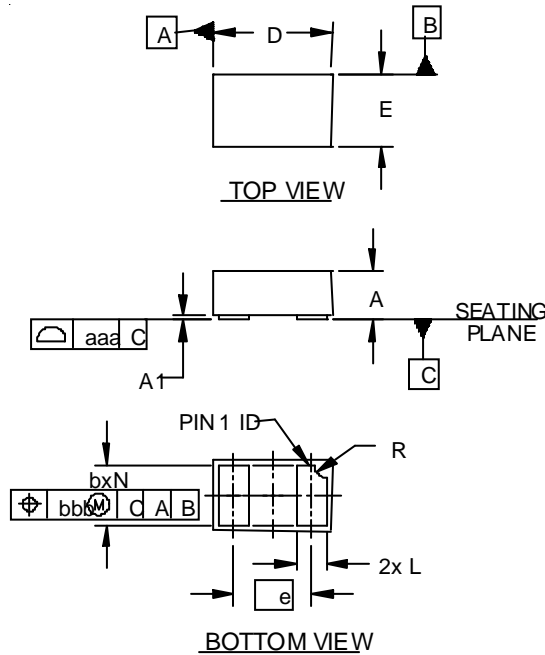

Figure 1 - 3.3 volt vs. 5 volt TVS IV Curve

uClamp3311T Spice Model

uClamp3311T Spice Parameters			
Parameter	Unit	D1 (TVS)	D2 (TVS)
IS	Amp	1E-20	1E-20
BV	Volt	2.8	2.8
VJ	Volt	0.7	0.7
RS	Ohm	0.2	0.2
IBV	Amp	1E-3	1E-3
CJO	Farad	10E-12	1E-12
TT	sec	2.541E-9	2.541E-9
M	--	0.05	0.05
N	--	1.1	1.1
EG	eV	1.11	1.11



DIM	INCHES		MILLIMETERS	
	MIN	NOMMAX	MIN	NOMMAX
A	.015	.016 .017	0.37	0.40 0.43
A1	.000	.001 .002	0.00	0.03 0.05
b	.018	.020 .022	0.45	0.50 0.55
D	.035	.039 .043	0.90	1.00 1.10
E	.020	.024 .028	0.50	0.60 0.70
e	.026 BSC		0.65 BSC	
L	.008	.010 .012	0.20	0.25 0.30
R	.002	.004 .006	0.05	0.10 0.15
N	2		2	
aaa	.003		0.08	
bbb	.004		0.10	

NOTES:

1. CONTROLLING DIMENSIONS ARE IN MILLIMETERS (ANGLES IN DEGREES).

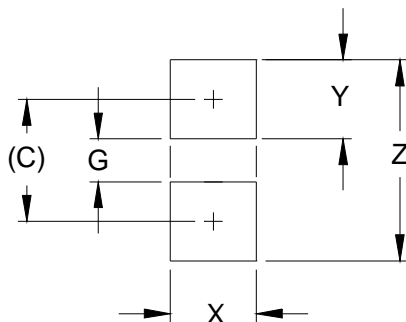

DIM	DIMENSIONS	
	INCHES	MILLIMETERS
C	(.033)	(0.85)
G	.012	0.30
X	.024	0.60
Y	.022	0.55
Z	.055	1.40

NOTES:

1. CONTROLLING DIMENSIONS ARE IN MILLIMETERS (ANGLES IN DEGREES).
2. THIS LAND PATTERN IS FOR REFERENCE PURPOSES ONLY.
CONSULT YOUR MANUFACTURING GROUP TO ENSURE YOUR COMPANY'S MANUFACTURING GUIDELINES ARE MET.

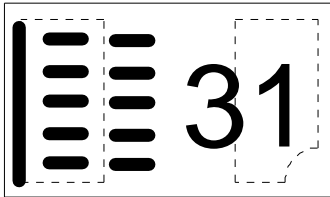

Part Number	Qty per Reel	Reel Size
uClamp3311T.TCT	3,000	7 Inch
uClamp3311T.TNT	10,000	7 Inch

Notes:

- 1) Device is electrically symmetrical
- 2) Marking will also include line matrix date code

MicroClamp, uClamp and μ Clamp are trademarks of Semtech Corporation

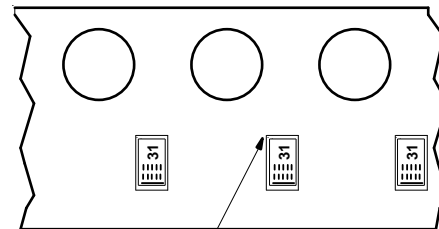
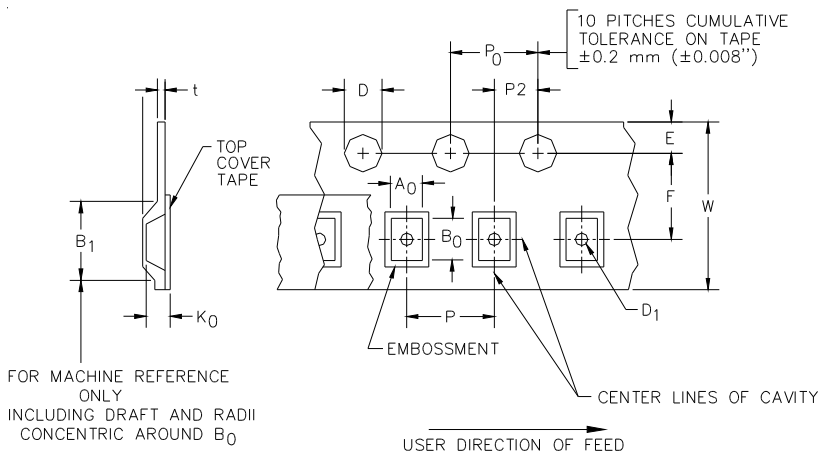

**Pin 1 Location
(Towards Sprocket Holes)**

Device Orientation in Tape

A0	B0	K0
0.69 +/-0.10 mm	1.19 +/-0.10 mm	0.66 +/-0.10 mm

Tape Width	B, (Max)	D	D1	E	F	P	P0	P2	T	W
8 mm	4.2 mm (.165)	1.5 + 0.1 mm - 0.0 mm (0.59 +0.05 -.000)	0.4 mm ± 0.25 (.031)	1.750 \pm .10 mm (.069 \pm .004)	3.5 \pm 0.05 mm (.138 \pm .002)	4.0 \pm 0.10 mm (.157 \pm .004)	4.0 \pm 0.1 mm (.157 \pm .004)	2.0 \pm 0.05 mm (.079 \pm .002)	0.254 \pm 0.02 mm (.016)	8.0 mm + 0.3 mm - 0.1 mm (.312 \pm .012)

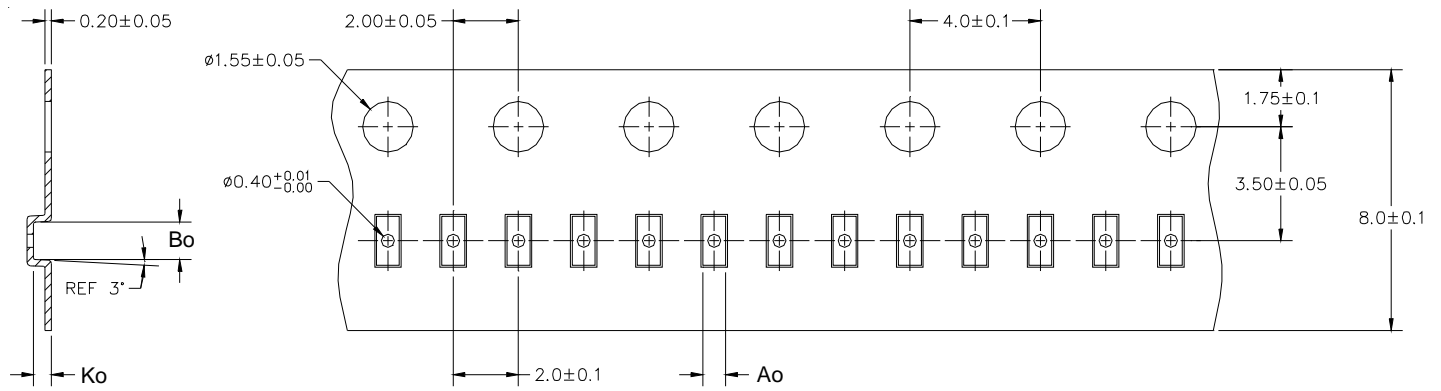

A0	B0	K0
0.70 +/-0.05 mm	1.15 +/-0.05 mm	0.55 +/-0.05 mm

Note: All dimensions in mm unless otherwise specified

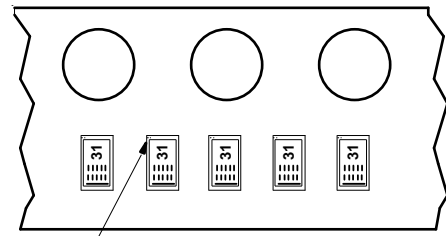



Pin 1 Location
(Towards Sprocket Holes)

Device Orientation in Tape

Semtech Corporation
Protection Products Division
200 Flynn Road, Camarillo, CA 93012
Phone: (805)498-2111 FAX (805)498-3804

Looking for pricing, stock, or lifecycle information?

Click below to explore more details on WIN SOURCE:

-  [View UCLAMP3311T.TCT on WIN SOURCE](#)
-  [Semtech Corporation](#) Information

Optimize Your Supply Chain with WIN SOURCE Solutions

-  Global Sourcing Solution
-  Obsolete Management
-  Cost Control Management
-  Shortage Management
-  Alternative Solution
-  Excess Inventory Management