

## PROTECTION PRODUCTS - MicroClamp™

### Description

The μClamp™ series of TVS arrays are designed to protect sensitive electronics from damage or latch-up due to ESD. They are designed for use in applications where board space is at a premium. Each device requires less than 2.9mm<sup>2</sup> of PCB area and will protect up to five lines. They are unidirectional devices and may be used on lines where the signal polarities are above ground.

TVS diodes are solid-state devices designed specifically for transient suppression. They feature large cross-sectional area junctions for conducting high transient currents. They offer desirable characteristics for board level protection including fast response time, low operating and clamping voltage, and no device degradation.

The uClamp™0505A may be used to meet the immunity requirements of IEC 61000-4-2, level 4. The small SC89 package makes them ideal for use in portable electronics such as cell phones, PDA's, notebook computers, and digital cameras. These devices feature a lead-free, matte tin lead finish. They are compatible with both lead free and SnPb assembly techniques.

### Features

- ◆ Transient protection for data lines to **IEC 61000-4-2 (ESD) ±15kV (air), ±8kV (contact) IEC 61000-4-4 (EFT) 40A (5/50ns)**
- ◆ Protects five I/O lines
- ◆ Ultra-small SC-89 package (**1.7 x 1.7 x 0.6mm**) requires less than 2.9mm<sup>2</sup> of PCB area
- ◆ Working voltage: 5V
- ◆ Low leakage current
- ◆ Low operating and clamping voltages
- ◆ Solid-state silicon-avalanche technology

### Mechanical Characteristics

- ◆ SC-89 (SOT-666) package
- ◆ Molding compound flammability rating: UL 94V-0
- ◆ Marking : Marking Code and pin 1 indicator
- ◆ Weight: 2.9mg (typical)
- ◆ Lead Finish: Matte Tin
- ◆ Packaging : Tape and Reel per EIA 481

### Applications

- ◆ Cellular Handsets & Accessories
- ◆ Cordless Phones
- ◆ Personal Digital Assistants (PDA's)
- ◆ Notebooks & Handhelds
- ◆ Portable Instrumentation
- ◆ Digital Cameras
- ◆ Peripherals
- ◆ MP3 Players

### Dimensions

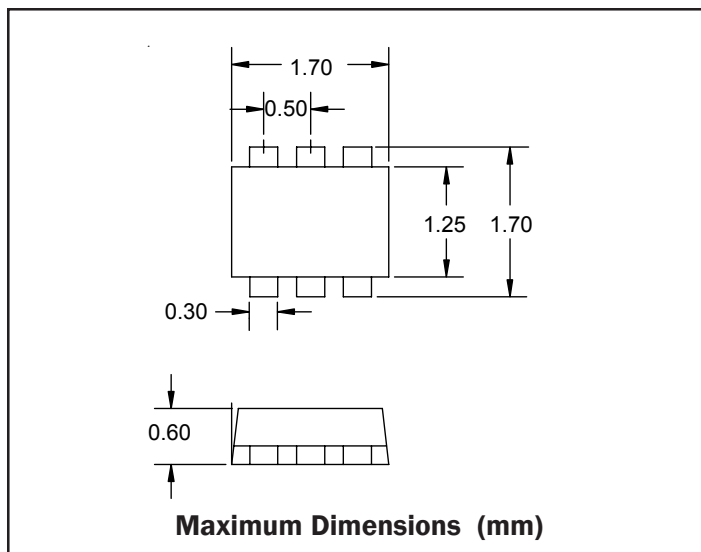

### Schematic & PIN Configuration

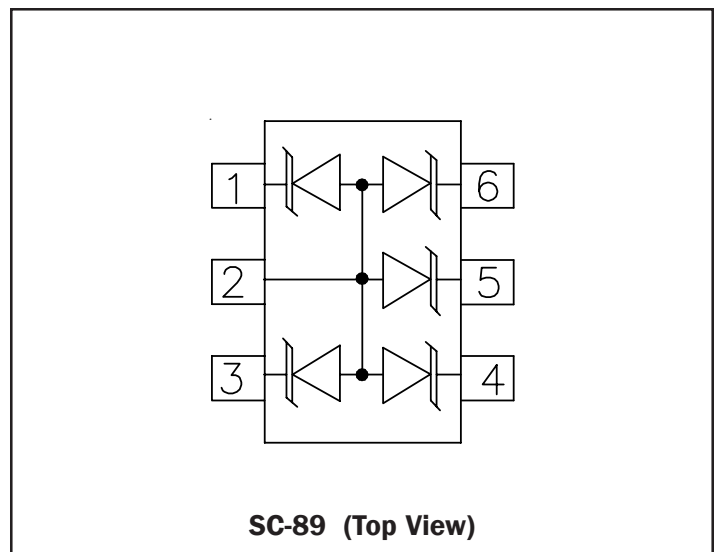

**PROTECTION PRODUCTS**
**Absolute Maximum Rating**

Rating	Symbol	Value	Units
Peak Pulse Power (tp = 8/20μs)	$P_{pk}$	100	Watts
Maximum Peak Pulse Current ( tp = 8/20μs)	$I_{pp}$	7	Amps
ESD per IEC 61000-4-2 (Air) ESD per IEC 61000-4-2 (Contact)	$V_{pp}$	+/- 20 +/- 12	kV
Lead Soldering Temperature	$T_L$	260 (10 sec.)	°C
Operating Temperature	$T_J$	-55 to +125	°C
Storage Temperature	$T_{STG}$	-55 to +150	°C

**Electrical Characteristics (T=25°C)**

Parameter	Symbol	Conditions	Minimum	Typical	Maximum	Units
Reverse Stand-Off Voltage	$V_{RWM}$				5	V
Reverse Breakdown Voltage	$V_{BR}$	$I_t = 1mA$	6			V
Reverse Leakage Current	$I_R$	$V_{RWM} = 5V, T=25°C$			1	μA
Reverse Leakage Current	$I_R$	$V_{RWM} = 3V, T=25°C$			0.500	μA
Forward Voltage	$V_F$	$I_F = 10mA$		0.80		V
Clamping Voltage	$V_C$	$I_{pp} = 1A, t_p = 8/20μs$			10	V
Clamping Voltage	$V_C$	$I_{pp} = 7A, t_p = 8/20μs$			12	V
Junction Capacitance	$C_j$	Between I/O Pins and Gnd $V_R = 0V, f = 1MHz$		60	75	pF

PROTECTION PRODUCTS

Typical Characteristics

Non-Repetitive Peak Pulse Power vs. Pulse Time

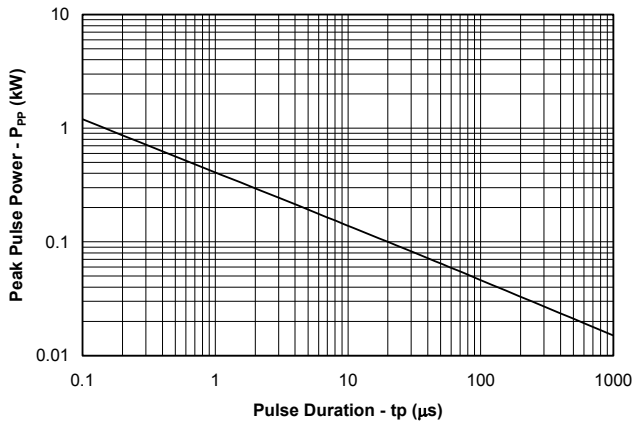

Power Derating Curve

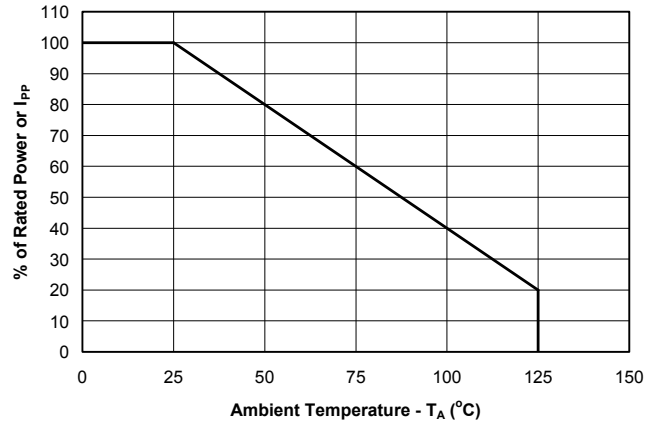

Clamping Voltage vs. Peak Pulse Current

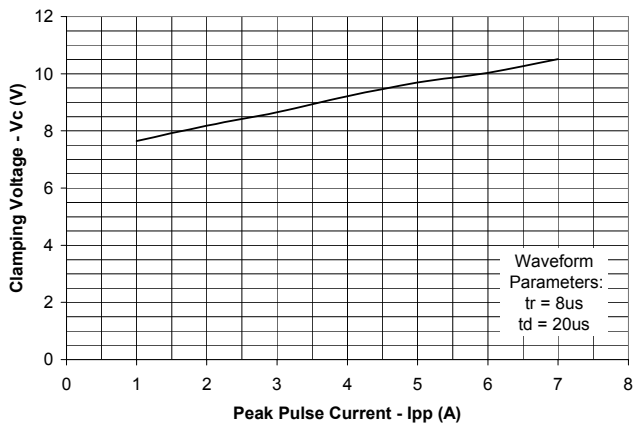

Forward Voltage vs. Forward Current

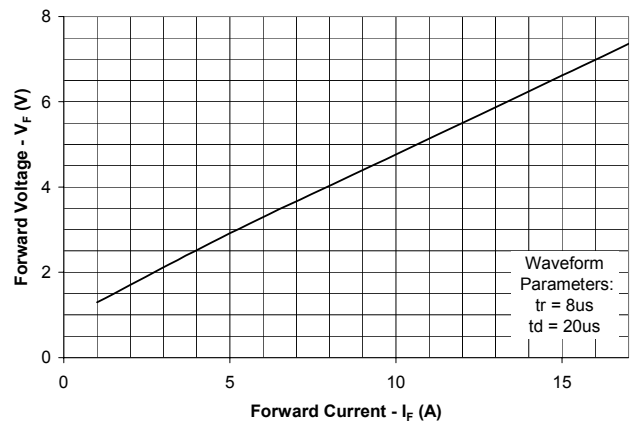

Junction Capacitance vs. Reverse Voltage

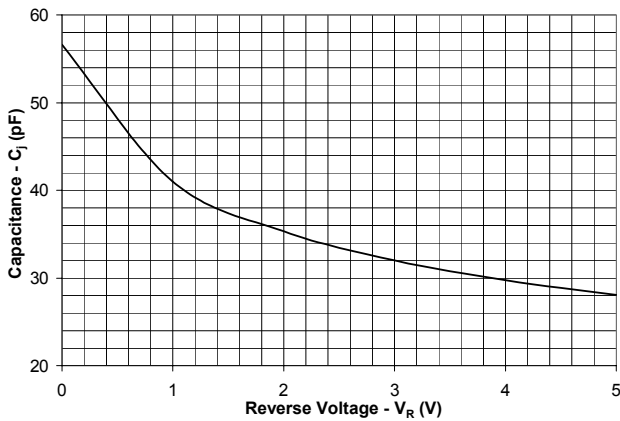

Insertion Loss S21

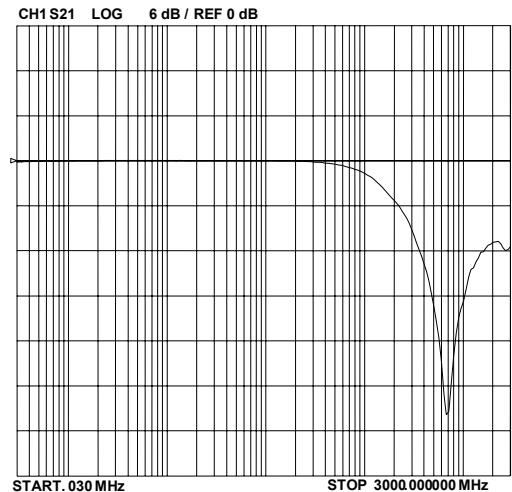

PROTECTION PRODUCTS

Typical Characteristics (Con't.)

**ESD Clamping  
(8kV Contact per IEC 61000-4-2)**

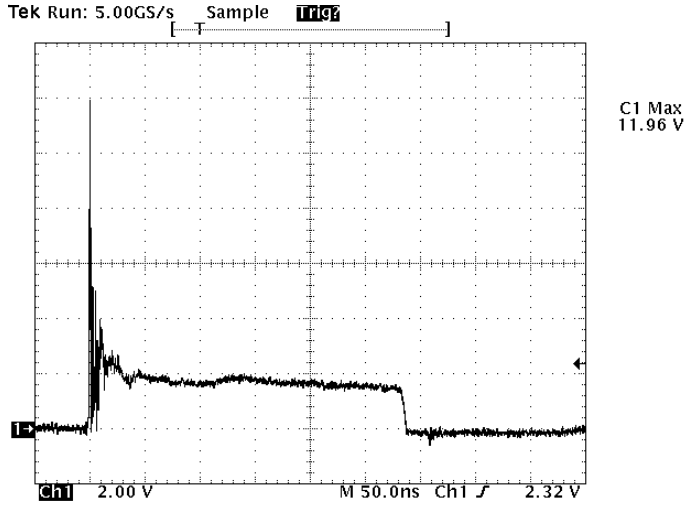

**ESD Clamping  
(-8kV Contact per IEC 61000-4-2)**

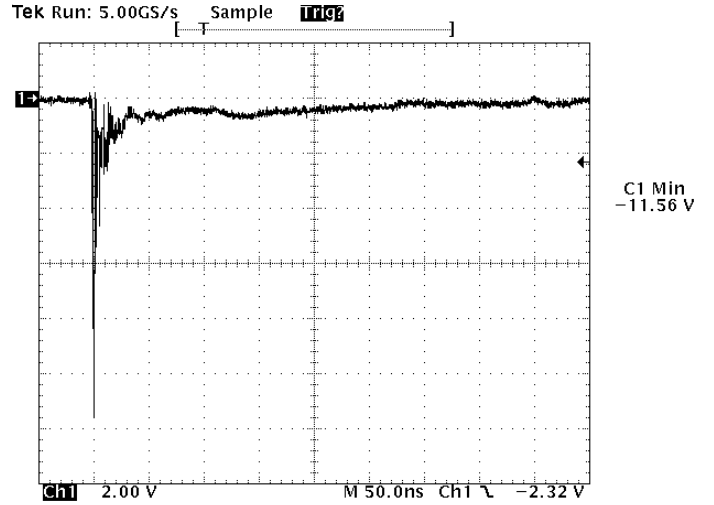

**ESD Clamping  
(15kV air per IEC 61000-4-2)**

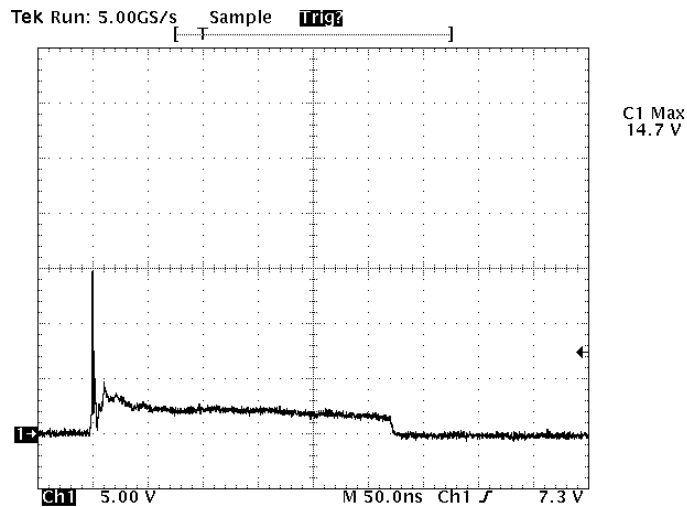

**ESD Clamping  
(-15kV air per IEC 61000-4-2)**

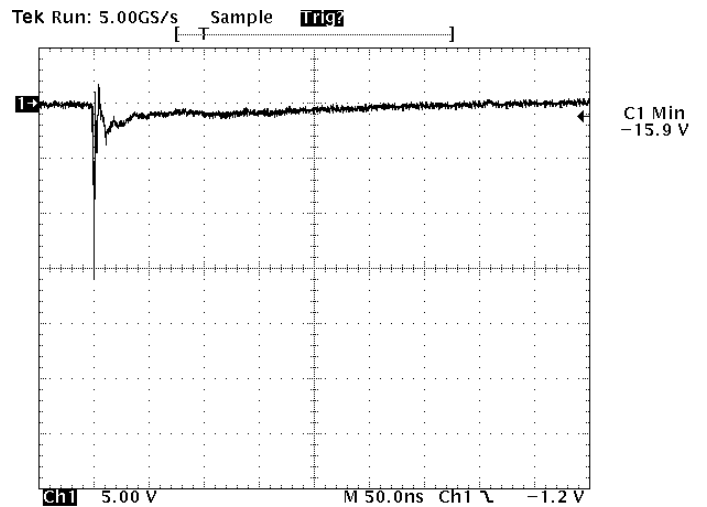

## PROTECTION PRODUCTS

### Applications Information

#### Device Connection for Protection of Five Data Lines

These devices are designed to protect up to five unidirectional data lines. The device is connected as follows:

1. Unidirectional protection of five I/O lines is achieved by connecting pins 1, 3, 4, 5, and 6 to the data lines. Pin 2 is connected to ground. The ground connection should be made directly to the ground plane for best results. The path length is kept as short as possible to reduce the effects of parasitic inductance in the board traces.

#### Circuit Board Layout Recommendations for Suppression of ESD.

Good circuit board layout is critical for the suppression of ESD induced transients. The following guidelines are recommended:

- Place the TVS near the input terminals or connectors to restrict transient coupling.
- Minimize the path length between the TVS and the protected line.
- Minimize all conductive loops including power and ground loops.
- The ESD transient return path to ground should be kept as short as possible.
- Never run critical signals near board edges.
- Use ground planes whenever possible.

#### Matte Tin Lead Finish

Matte tin has become the industry standard lead-free replacement for SnPb lead finishes. A matte tin finish is composed of 100% tin solder with large grains. Since the solder volume on the leads is small compared to the solder paste volume that is placed on the land pattern of the PCB, the reflow profile will be determined by the requirements of the solder paste. Therefore, these devices are compatible with both lead-free and SnPb assembly techniques. In addition, unlike other lead-free compositions, matte tin does not have any added alloys that can cause degradation of the solder joint.

#### Circuit Diagram

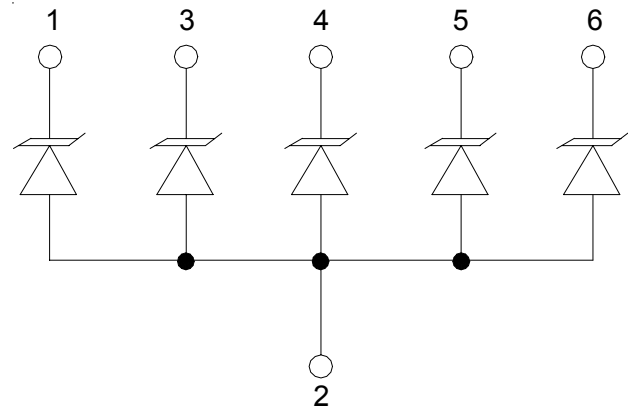

#### Protection of Five Unidirectional Lines

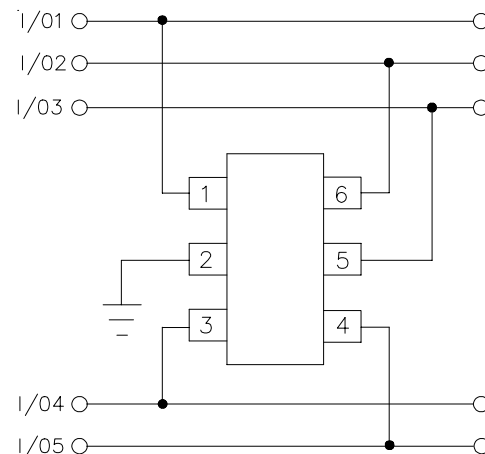

**PROTECTION PRODUCTS**

Typical Applications

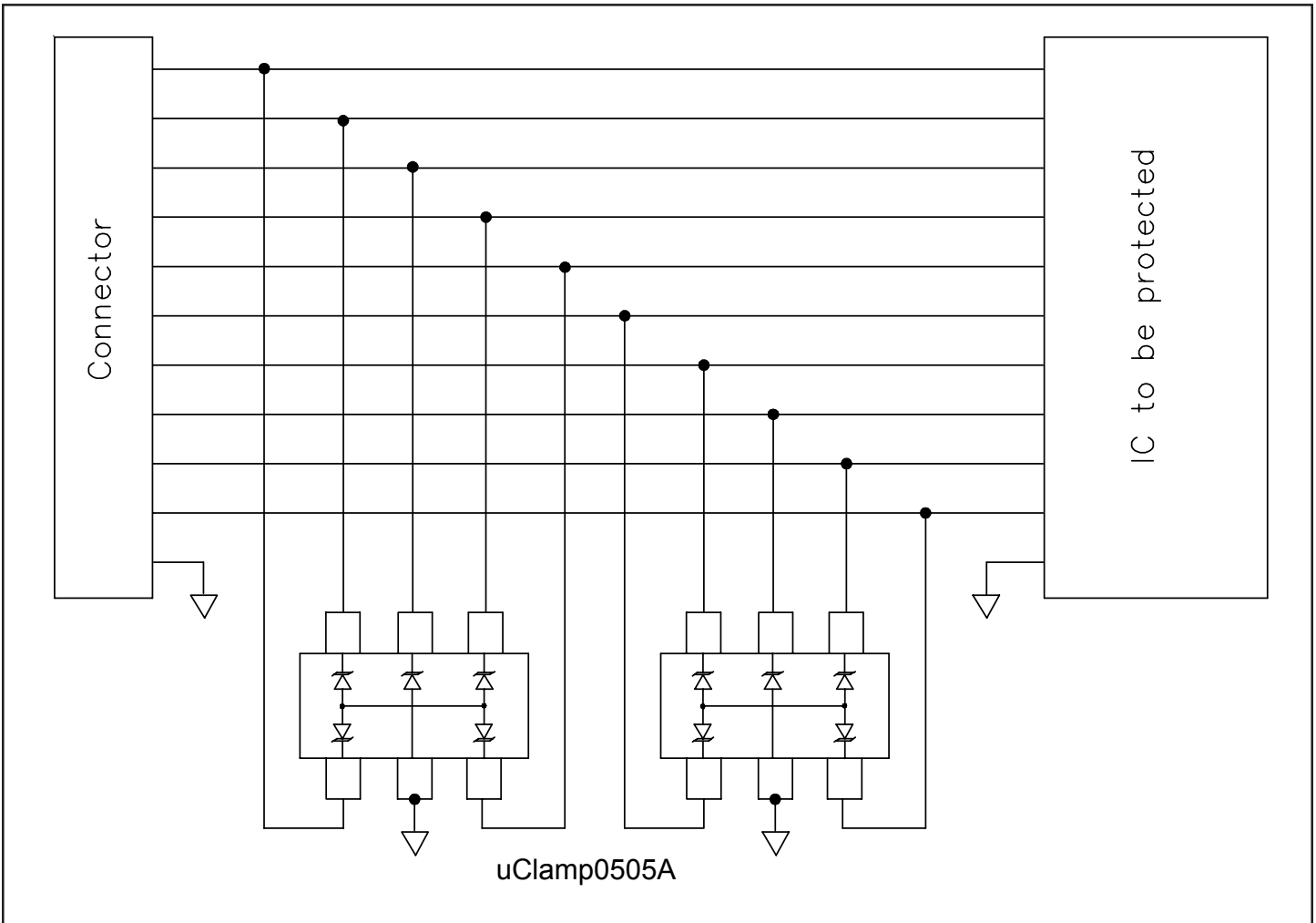

PROTECTION PRODUCTS

Outline Drawing - SC-89 (SOT-666)

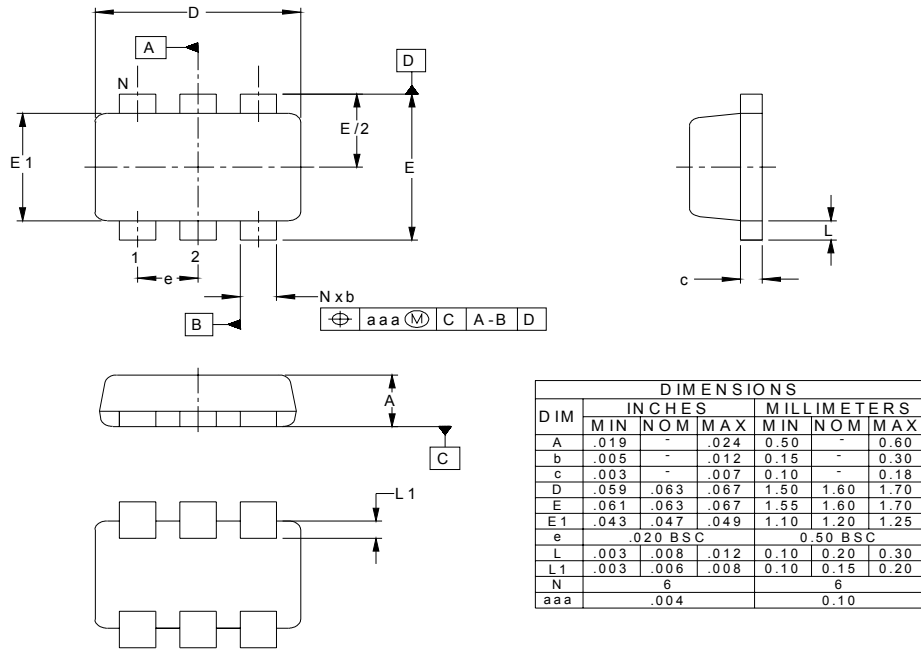

NOTES:

1. CONTROLLING DIMENSIONS ARE IN MILLIMETERS (ANGLES IN DEGREES).
2. DIMENSIONS "E1" AND "D" DO NOT INCLUDE MOLD FLASH, PROTRUSIONS OR GATE BURRS.

Land Pattern - SC-89 (SOT-666)

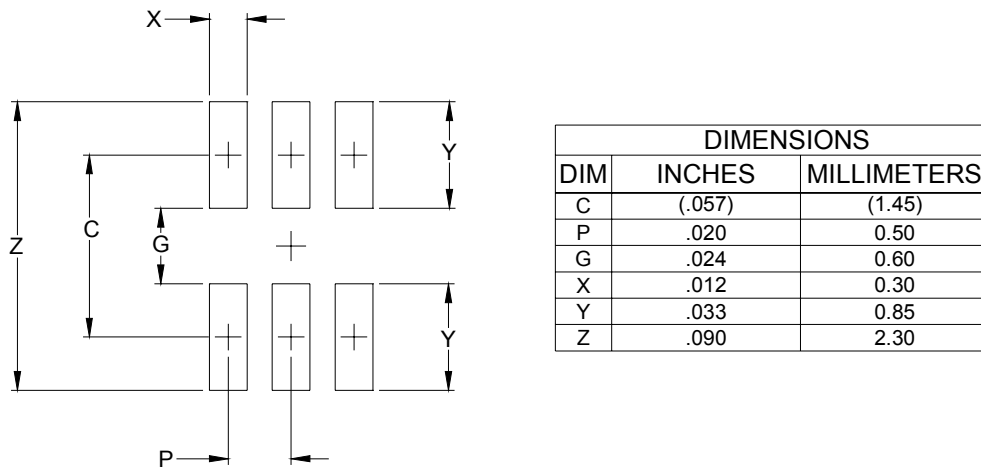

NOTES:

1. THIS LAND PATTERN IS FOR REFERENCE PURPOSES ONLY CONSULT YOUR MANUFACTURING GROUP TO ENSURE YOUR COMPANY'S MANUFACTURING GUIDELINES ARE MET.

**PROTECTION PRODUCTS**

**Marking Code**

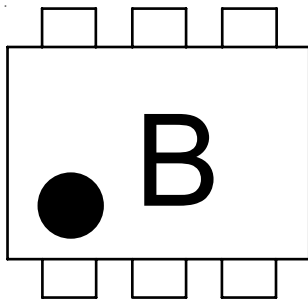

**Ordering Information**

Part Number	Working Voltage	Device Marking	Qty per Reel	Reel Size
uClamp0505A.TCT	5V	B	3,000	7 Inch

MicroClamp, uClamp and  $\mu$ Clamp are trademarks of Semtech Corporation

**Note:**

- (1) Pin 1 Identified with a dot
- (2) Lead finish is matte tin

**Tape and Reel Specification**

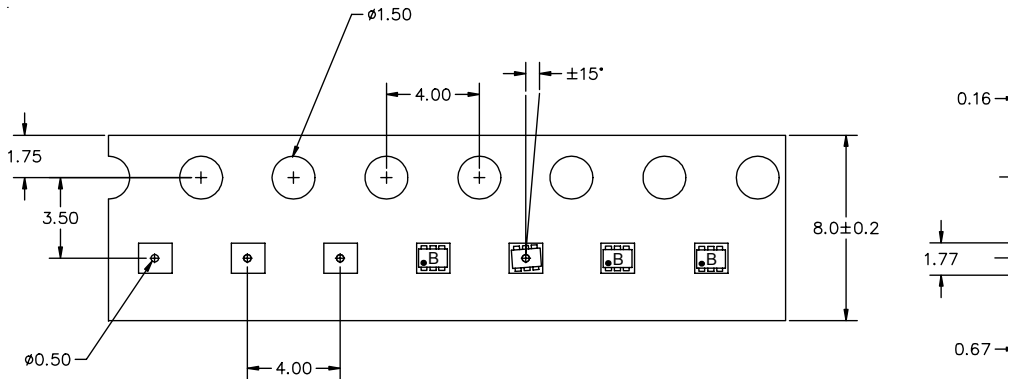

☐ DIMENSIONS ARE IN MILLIMETERS.

☐ SAME AS 3M US046041.



**Tape Specification and Device Orientation**

**Contact Information**

Semtech Corporation  
 Protection Products Division  
 200 Flynn Rd., Camarillo, CA 93012  
 Phone: (805)498-2111 FAX (805)498-3804

## Looking for pricing, stock, or lifecycle information?

Click below to explore more details on WIN SOURCE:

-  [View UCLAMP0505A.TCT on WIN SOURCE](#)
-  [Semtech Corporation](#) Information

## Optimize Your Supply Chain with WIN SOURCE Solutions

-  Global Sourcing Solution
-  Obsolete Management
-  Cost Control Management
-  Shortage Management
-  Alternative Solution
-  Excess Inventory Management