



**THE DATASHEET OF
UCD1V331MNL1GS**



ALUMINUM ELECTROLYTIC CAPACITORS

UCD Chip Type, Low Impedance



- Chip type, low impedance temperature range up to +105°C.
- Designed for surface mounting on high density PC board.
- Applicable to automatic mounting machine fed with carrier tape.
- Compliant to the RoHS directive (2011/65/EU).
- AEC-Q200 compliant. Please contact us for details.



Specifications

| Item | Performance Characteristics | | | | | | | | | | |
|---|---|--|------|------|------|------|------|------|------|------|---|
| Category Temperature Range | - 55 to +105°C | | | | | | | | | | |
| Rated Voltage Range | 6.3 to 100V | | | | | | | | | | |
| Rated Capacitance Range | 1 to 3300μF | | | | | | | | | | |
| Capacitance Tolerance | ±20% at 120Hz, 20°C | | | | | | | | | | |
| Leakage Current | After 2 minutes' application of rated voltage at 20°C, leakage current is not more than 0.01 CV or 3 (μA), whichever is greater. | | | | | | | | | | |
| Tangent of loss angle (tan δ) | Measurement frequency : 120Hz at 20°C | | | | | | | | | | |
| | Rated voltage (V) | 6.3 | 10 | 16 | 25 | 35 | 50 | 63 | 80 | 100 | |
| | tan δ (MAX.) | 0.26 | 0.19 | 0.16 | 0.14 | 0.12 | 0.10 | 0.08 | 0.08 | 0.07 | |
| For capacitance of more than 1000μF, add 0.02 for every increase of 1000μF. | | | | | | | | | | | |
| Stability at Low Temperature | Measurement frequency : 120Hz | | | | | | | | | | |
| | Rated voltage (V) | 6.3 | 10 | 16 | 25 | 35 | 50 | 63 | 80 | 100 | |
| | Impedance ratio ZT / Z20 (MAX.) | Z-25°C / Z+20°C | 2 | 2 | 2 | 2 | 2 | 2 | 2 | 2 | 2 |
| | | Z-40°C / Z+20°C | 3 | 3 | 3 | 3 | 3 | 3 | 3 | 3 | 3 |
| Z-55°C / Z+20°C | | 4 | 4 | 4 | 3 | 3 | 3 | 3 | 3 | 3 | |
| Endurance | The specifications listed at right shall be met when the capacitors are restored to 20°C after the rated voltage is applied for 5000 hours (2000 hours for L < 10 mm: 50V or less, and for L ≤ 10mm: 63V or more) at 105°C. | | | | | | | | | | |
| | Capacitance Change | Within ± 30% of the initial capacitance value | | | | | | | | | |
| | tan δ | 200% or less than the initial specified value 300% or less than the initial specified value for 63V or more | | | | | | | | | |
| Shelf Life | After storing the capacitors under no load at 105°C for 1000 hours and then performing voltage treatment based on JIS C 5101-4 clause 4.1 at 20°C, they shall meet the specified values for the endurance characteristics listed above. | | | | | | | | | | |
| | Capacitance Change | Within ± 10% of the initial capacitance value | | | | | | | | | |
| | tan δ | Less than or equal to the initial specified value | | | | | | | | | |
| Resistance to soldering heat | The capacitors are kept on a hot plate for 30 seconds, which is maintained at 250°C. The capacitors shall meet the characteristic requirements listed at right when they are removed from the plate and restored to 20°C. | | | | | | | | | | |
| | Capacitance Change | Within ± 10% of the initial capacitance value | | | | | | | | | |
| | Leakage current | Less than or equal to the initial specified value | | | | | | | | | |
| Marking | Black print on the case top. | | | | | | | | | | |

Chip Type

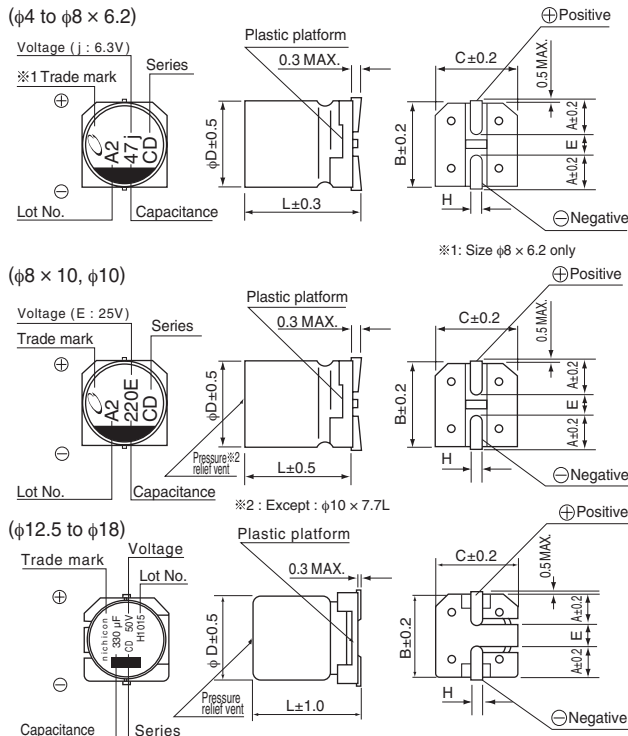

※φ8 × 10L, φ10 × 10L, φ12.5 × 13.5L, φ16 × 16.5L, φ18 × 16.5L :
The vibration structure-resistant product is also available upon request, please ask for details.

Type numbering system (Example : 16V 100μF)

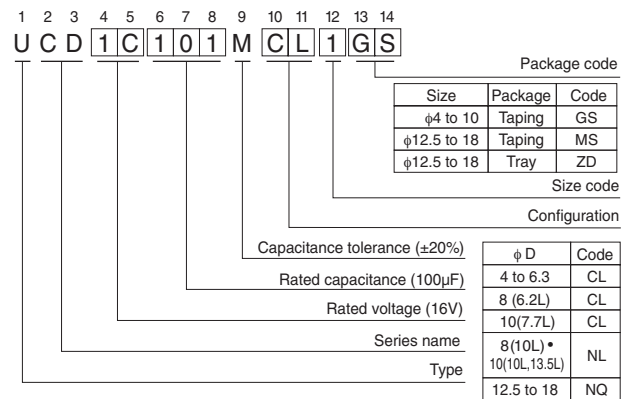

| φD × L | 4 × 5.8 | 5 × 5.8 | 6.3 × 5.8 | 6.3 × 7.7 | 8 × 6.2 | 8 × 10 | 10 × 7.7 | 10 × 10 | (mm) |
|--------|------------|------------|------------|------------|------------|------------|------------|------------|------|
| A | 1.8 | 2.1 | 2.4 | 2.4 | 3.3 | 2.9 | 3.2 | 3.2 | |
| B | 4.3 | 5.3 | 6.6 | 6.6 | 8.3 | 8.3 | 10.3 | 10.3 | |
| C | 4.3 | 5.3 | 6.6 | 6.6 | 8.3 | 8.3 | 10.3 | 10.3 | |
| E | 1.0 | 1.3 | 2.2 | 2.2 | 2.3 | 3.1 | 4.5 | 4.5 | |
| L | 5.8 | 5.8 | 5.8 | 7.7 | 6.2 | 10 | 7.7 | 10 | |
| H | 0.5 to 0.8 | 0.5 to 0.8 | 0.5 to 0.8 | 0.5 to 0.8 | 0.5 to 0.8 | 0.8 to 1.1 | 0.8 to 1.1 | 0.8 to 1.1 | |

| φD × L | 10 × 13.5 | 12.5 × 13.5 | 16 × 16.5 | 18 × 16.5 |
|--------|------------|-------------|------------|------------|
| A | 3.2 | 4.8 | 5.4 | 6.4 |
| B | 10.3 | 13.6 | 17.1 | 19.1 |
| C | 10.3 | 13.6 | 17.1 | 19.1 |
| E | 4.5 | 4.0 | 6.3 | 6.3 |
| L | 13.5 | 13.5 | 16.5 | 16.5 |
| H | 0.8 to 1.1 | 1.0 to 1.4 | 1.0 to 1.4 | 1.0 to 1.4 |



Voltage

| V | 6.3 | 10 | 16 | 25 | 35 | 50 | 63 | 80 | 100 |
|------|-----|----|----|----|----|----|----|----|-----|
| Code | j | A | C | E | V | H | J | K | 2A |

• Dimension table in next page.

Looking for pricing, stock, or lifecycle information?

Click below to explore more details on WIN SOURCE:

-  [View UCD1V331MNL1GS on WIN SOURCE](#)
-  [Nichicon Information](#)

Optimize Your Supply Chain with WIN SOURCE Solutions

-  Global Sourcing Solution
-  Obsolete Management
-  Cost Control Management
-  Shortage Management
-  Alternative Solution
-  Excess Inventory Management