



**THE DATASHEET OF
UCC2895PW**



BiCMOS Advanced Phase-Shift PWM Controller

 Check for Samples: [UCC1895](#), [UCC2895](#), [UCC3895](#)

FEATURES

- Programmable-Output Turnon Delay
- Adaptive Delay Set
- Bidirectional Oscillator Synchronization
- Voltage-Mode, Peak Current-Mode, or Average Current-Mode Control
- Programmable Softstart, Softstop and Chip Disable via a Single Pin
- 0% to 100% Duty-Cycle Control
- 7-MHz Error Amplifier
- Operation to 1 MHz
- Typical 5-mA Operating Current at 500 kHz
- Very Low 150- μ A Current During UVLO

APPLICATIONS

- Phase-Shifted Full-Bridge Converters
- Off-Line, Telecom, Datacom and Servers
- Distributed Power Architecture
- High-Density Power Modules

DESCRIPTION

The UCC3895 is a phase-shift PWM controller that implements control of a full-bridge power stage by phase shifting the switching of one half-bridge with respect to the other. The device allows constant frequency pulse-width modulation in conjunction with resonant zero-voltage switching to provide high efficiency at high frequencies. The part is used either as a voltage-mode or current-mode controller.

While the UCC3895 maintains the functionality of the UC3875/6/7/8 family and UC3879, it improves on that controller family with additional features such as enhanced control logic, adaptive delay set, and shutdown capability. Because the device is built using the BCDMOS process, it operates with dramatically less supply current than its bipolar counterparts. The UCC3895 operates with a maximum clock frequency of 1 MHz.

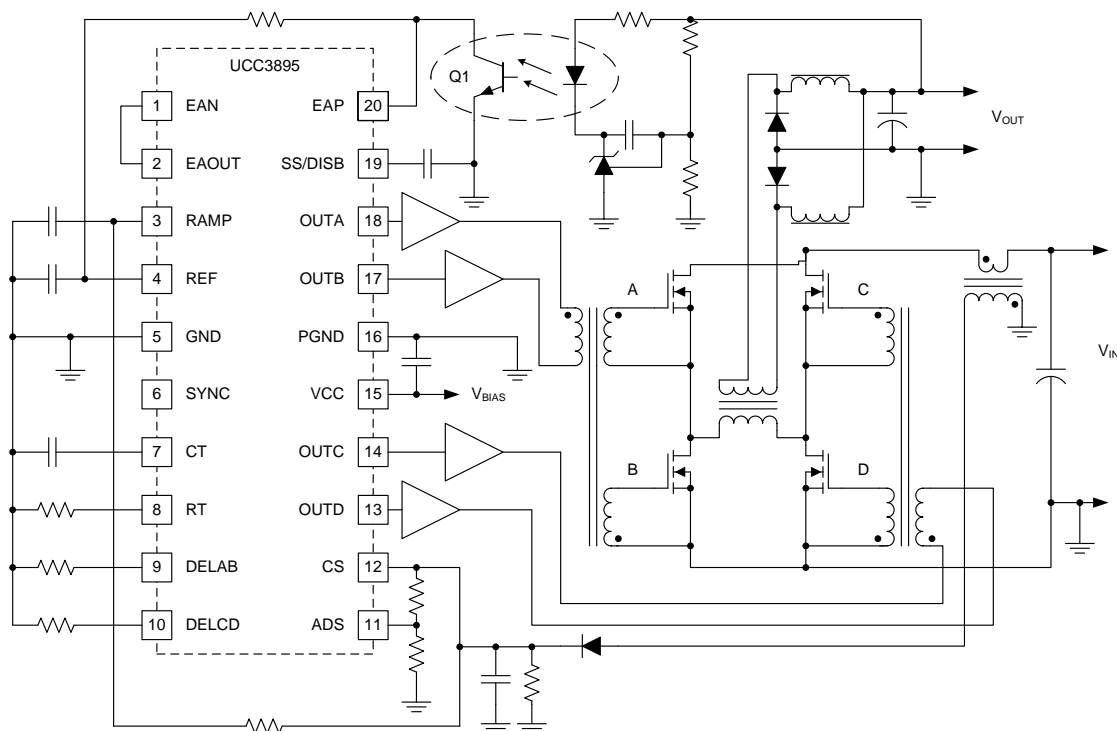

Please be aware that an important notice concerning availability, standard warranty, and use in critical applications of Texas Instruments semiconductor products and disclaimers thereto appears at the end of this data sheet.



This integrated circuit can be damaged by ESD. Texas Instruments recommends that all integrated circuits be handled with appropriate precautions. Failure to observe proper handling and installation procedures can cause damage.

ESD damage can range from subtle performance degradation to complete device failure. Precision integrated circuits may be more susceptible to damage because very small parametric changes could cause the device not to meet its published specifications.

ORDERING INFORMATION

T _A	PACKAGED DEVICES					
	SOIC-20 (DW) ⁽¹⁾	PDIP-20 (N)	TSSOP-20 (PW) ⁽¹⁾	PLCC-20 (FN) ⁽¹⁾	LCCC-20 (FK)	CDIP-20 (J)
–55°C to +125°C					UCC1895L	UCC1895J
–40°C to +85°C	UCC2895DW	UCC2895N	UCC2895PW	UCC2895Q		
0°C to 70°C	UCC3895DW	UCC3895N	UCC3895PW	UCC3895Q		

(1) The DW, PW and Q packages are available taped and reeled. Add TR suffix to device type (for example: UCC2895DWTR) to order quantities of 2000 devices per reel for DW.

ABSOLUTE MAXIMUM RATINGS

All voltage values are with respect to the network ground terminal unless otherwise noted.⁽¹⁾

		VALUE		UNIT
		MIN	MAX	
Supply voltage			17	V
Output current			100	mA
Reference current			15	
Supply current			30	
Analog inputs	EAP, EAN, EAOUT, RAMP, SYNC, ADS, CS, SS/DISB	–0.3	REF + 0.3	V
Drive outputs	OUTA, OUTB, OUTC, OUTD	–0.3	VCC + 0.3	
Power dissipation at T _A = 25°C	DW-20 package		650	mW
	N-20 package		1	W
T _J Junction temperature range		–55	150	°C
Lead temperature 1.6 mm (1/16 in) from case for 10 seconds			300	
T _{stg} Storage temperature range		–65	150	

(1) Stresses beyond those listed under *absolute maximum ratings* may cause permanent damage to the device. These are stress ratings only, and functional operation of the device at these or any other conditions beyond those indicated under *recommended operating conditions* is not implied. Exposure to Absolute Maximum Rated conditions for extended periods may affect device reliability

THERMAL CHARACTERISTICS

PART	T _{JA}	T _{JC}	UNIT
UCC2895DW	90	25	°C/W
UCC2895N	80	35	
UCC2895PW	125	14	
UCC2895Q	75	34	
UCC1895J	85	28	
UCC1895L	80	20	

RECOMMENDED OPERATING CONDITIONS⁽¹⁾

		MIN	NOM	MAX	UNIT
V _{DD}	Supply voltage	10		16.5	V
V _{DD}	Supply voltage bypass capacitor ⁽²⁾	10 × C _{REF}			μF
C _{REF}	Reference bypass capacitor (UCC1895) ⁽³⁾	0.1		1.0	
C _{REF}	Reference bypass capacitor (UCC2895, UCC3895) ⁽³⁾	0.1		4.7	
C _T	Timing capacitor (for 500-kHz switching frequency)	220			pF
R _T	Timing resistor (for 500-kHz switching frequency)	82			kΩ
R _{DEL_AB} , R _{DEL_CD}	Delay resistor	2.5		40	
T _J	Operating junction temperature ⁽⁴⁾	–55		125	°C

- (1) TI recommends that there be a single point grounded between GND and PGND directly under the device. There must be a separate ground plane associated with the GND pin and all components associated with pins 1 through 12, plus 19 and 20, be located over this ground plane. Any connections associated with these pins to ground must be connected to this ground plane.
- (2) The V_{DD} capacitor must be a low ESR, ESL ceramic capacitor located directly across the VDD and PGND pins. A larger bulk capacitor must be located as physically close as possible to the V_{DD} pins.
- (3) The V_{REF} capacitor must be a low ESR, ESL ceramic capacitor located directly across the REF and GND pins. If a larger capacitor is desired for the V_{REF} then it must be located near the V_{REF} cap and connected to the V_{REF} pin with a resistor of 51 Ω or greater. The bulk capacitor on V_{DD} must be a factor of 10 greater than the total V_{REF} capacitance.
- (4) TI does not recommend that the device operate under conditions beyond those specified in this table for extended periods of time.

ELECTRICAL CHARACTERISTICS

V_{DD} = 12 V, R_T = 82 kΩ, C_T = 220 pF, R_{DELAB} = 10 kΩ, R_{DELCD} = 10 kΩ, C_{REF} = 0.1 μF, C_{VDD} = 0.1 μF and no load on the outputs, T_A = T_J. T_A = 0°C to 70°C for UCC3895x, T_A = –40°C to +85°C for UCC2895x and T_A = –55°C to +125°C for the UCC1895x. (unless otherwise noted)

PARAMETER		TEST CONDITIONS	MIN	TYP	MAX	UNIT
UVLO (UNDERVOLTAGE LOCKOUT)						
UVLO _(on)	Start-up voltage threshold		10.2	11	11.8	V
UVLO _(off)	Minimum operating voltage after start-up		8.2	9	9.8	
UVLO _(hys)	Hysteresis		1	2	3	
SUPPLY						
I _{START}	Start-up current	V _{DD} = 8 V		150	250	μA
I _{DD}	Operating current			5	6	mA
V _{DD_CLAMP}	V _{DD} clamp voltage	I _{DD} = 10 mA	16.5	17.5	18.5	V
VOLTAGE REFERENCE						
V _{REF}	Output voltage	T _J = 25°C	4.94	5	5.06	V
		10 V < V _{DD} < V _{DD_CLAMP} 0 mA < I _{REF} < 5 mA temperature	4.85	5	5.15	
I _{SC}	Short circuit current	REF = 0 V, T _J = 25°C	10	20		mA
ERROR AMPLIFIER						
	Common-mode input voltage range		–0.1		3.6	V
V _{IO}	Offset voltage		–7		7	mV
I _{BIAS}	Input bias current (EAP, EAN)		–1		1	μA
EAOUT _{_VOH}	High-level output voltage	EAP-EAN = 500 mV, I _{EAOUT} = –0.5 mA	4	4.5	5	V
EAOUT _{_VOL}	Low-level output voltage	EAP-EAN = –500 mV, I _{EAOUT} = 0.5 mA	0	0.2	0.4	
I _{SOURCE}	Error amplifier output source current	EAP-EAN = 500 mV, EAOUT = 2.5 V	1	1.5		mA
I _{SINK}	Error amplifier output sink current	EAP-EAN = –500 mV, EAOUT = 2.5 V	2.5	4.5		
A _{VOL}	Open-loop dc gain		75	85		dB
GBW	Unity gain bandwidth ⁽¹⁾		5	7		mHz
	Slew rate ⁽¹⁾	1 V < EAN < 0 V, EAP = 500 mV 0.5 V < EAOUT < 3 V	1.5	2.2		V/μs

(1) Ensured by design. Not production tested.

ELECTRICAL CHARACTERISTICS (continued)

$V_{DD} = 12\text{ V}$, $R_T = 82\text{ k}\Omega$, $C_T = 220\text{ pF}$, $R_{DELAB} = 10\text{ k}\Omega$, $R_{DELCD} = 10\text{ k}\Omega$, $C_{REF} = 0.1\text{ }\mu\text{F}$, $C_{VDD} = 0.1\text{ }\mu\text{F}$ and no load on the outputs, $T_A = T_J$. $T_A = 0^\circ\text{C}$ to 70°C for UCC3895x, $T_A = -40^\circ\text{C}$ to $+85^\circ\text{C}$ for UCC2895x and $T_A = -55^\circ\text{C}$ to $+125^\circ\text{C}$ for the UCC1895x. (unless otherwise noted)

PARAMETER		TEST CONDITIONS	MIN	TYP	MAX	UNIT
	No-load comparator turn-off threshold		0.45	0.5	0.55	V
	No-load comparator turn-on threshold		0.55	0.6	0.69	
	No-load comparator hysteresis		0.035	0.1	0.165	
OSCILLATOR						
f_{OSC}	Frequency	$T_J = 25^\circ\text{C}$	473	500	527	kHz
	Frequency total variation(Over line, temperature		2.5%	5%	
V_{IH_SYNC}	SYNC input threshold, SYNC		2.05	2.1	2.4	V
V_{OH_SYNC}	High-level output voltage, SYNC	$I_{SYNC} = -400\text{ }\mu\text{A}$, $V_{CT} = 2.6\text{ V}$	4.1	4.5	5	
V_{OL_SYNC}	Low-level output voltage, SYNC	$I_{SYNC} = 100\text{ }\mu\text{A}$, $V_{CT} = 0\text{ V}$	0	0.5	1	
	Sync output pulse width	$LOAD_{SYNC} = 3.9\text{ k}\Omega$ and 30 pF in parallel		85	135	ns
V_{RT}	Timing resistor voltage		2.9	3	3.1	v
$V_{CT(peak)}$	Timing capacitor peak voltage		2.25	2.35	2.55	
$V_{CT(valley)}$	Timing capacitor valley voltage		0	0.2	0.4	
CURRENT SENSE						
$I_{CS(bias)}$	Current sense bias current	$0\text{ V} < CS < 2.5\text{ V}$ $0\text{ V ADS} < 2.5\text{ V}$	-4.5		20	μA
	Peak current threshold		1.9	2	2.1	V
	Overcurrent threshold		2.4	2.5	2.6	V
	Current sense to output delay	$0\text{ V} \leq CS \leq 2.3\text{ V}$ $DELAB = DELCD = REF$		75	110	ns
SOFT-START/SHUTDOWN						
I_{SOURCE}	Softstart source current	$SS/DISB = 3.0\text{ V}$ $CS = 1.9\text{ V}$	-40	-35	-30	μA
I_{SINK}	Softstart sink current	$SS/DISB = 3.0\text{ V}$, $CS = 2.6\text{ V}$	325	350	375	μA
	Softstart/disable comparator threshold		0.44	0.5	0.56	V
ADAPTIVE DELAY SET (ADS)						
	DELAB/DELCD output voltage	$ADS = CS = 0\text{ V}$	0.45	0.5	0.55	V
		$ADS = 0\text{ V}$ $CS = 2\text{ V}$	1.9	2	2.1	
t_{DELAY}	Output delay ⁽²⁾⁽³⁾	$ADS = CS = 0\text{ V}$	450	560	620	ns
	ADS bias current	$0\text{ V} < ADS < 2.5\text{ V}$ $0\text{ V} < CS < 2.5\text{ V}$	-20		20	μA

(2) Ensured by design. Not production tested.

(3) Output delay is measured between OUTA and OUTB, or OUTC and OUTD. Output delay is defined as shown below where: $t_{f(OUTA)}$ = falling edge of OUTA signal, $t_{r(OUTB)}$ = rising edge of OUTB signal (see Figure 1 and Figure 2).

ELECTRICAL CHARACTERISTICS (continued)

V_{DD} = 12 V, R_T = 82 kΩ, C_T = 220 pF, R_{DELAB} = 10 kΩ, R_{DELCD} = 10 kΩ, C_{REF} = 0.1 μF, C_{VDD} = 0.1 μF and no load on the outputs, T_A = T_J. T_A = 0°C to 70°C for UCC3895x, T_A = -40°C to +85°C for UCC2895x and T_A = -55°C to +125°C for the UCC1895x. (unless otherwise noted)

PARAMETER		TEST CONDITIONS	MIN	TYP	MAX	UNIT
OUTPUT						
V _{OH}	High-level output voltage (all outputs)	I _{OUT} = -10 mA, VDD to output		250	400	mV
V _{OL}	Low-level output voltage (all outputs)	I _{OUT} = 10 mA		150	250	mV
t _R	Rise time ⁽⁴⁾	C _{LOAD} = 100 pF		20	35	ns
t _F	Fall time ⁽⁴⁾	C _{LOAD} = 100 pF		20	35	ns
PWM COMPARATOR						
	EAOUT to RAMP input offset voltage	RAMP = 0 V DELAB = DELCD = REF	0.72	0.85	1.05	V
	Minimum phase shift ⁽⁵⁾ (OUTA to OUTC, OUTB to OUTD)	RAMP = 0 V EAOUT = 650 mV	0.0%	0.85%	1.4%	
t _{DELAY}	Delay ⁽⁶⁾ (RAMP to OUTC, RAMP to OUTD)	0 V < RAMP < 2.5 V, EAOUT = 1.2 V DELAB = DELCD = REF		70	120	ns
I _{R(bias)}	RAMP bias current	RAMP < 5 V, CT = 2.2 V	-5		5	μA
I _{R(sink)}	RAMP sink current	RAMP = 5 V, CT = 2.6 V	12	19		mA

(4) Ensured by design. Not production tested.

(5) Minimum phase shift is defined as:

$$\Phi = 180 \times \frac{t_{f(OUTC)} - t_{f(OUTA)}}{t_{PERIOD}} \quad \text{or} \quad \Phi = 180 \times \frac{t_{f(OUTC)} - t_{f(OUTB)}}{t_{PERIOD}}$$

where

- (a) t_{f(OUTA)} = falling edge of OUTA signal
- (b) t_{f(OUTB)} = falling edge of OUTB signal
- (c) t_{f(OUTC)} = falling edge of OUTC signal,
- (d) t_{f(OUTD)} = falling edge of OUTD signal
- (e) t_{PERIOD} = period of OUTA or OUTB signal

(6) Output delay is measured between OUTA and OUTB, or OUTC and OUTD. Output delay is defined as shown below where: t_{f(OUTA)} = falling edge of OUTA signal, t_{r(OUTB)} = rising edge of OUTB signal (see Figure 1 and Figure 2).

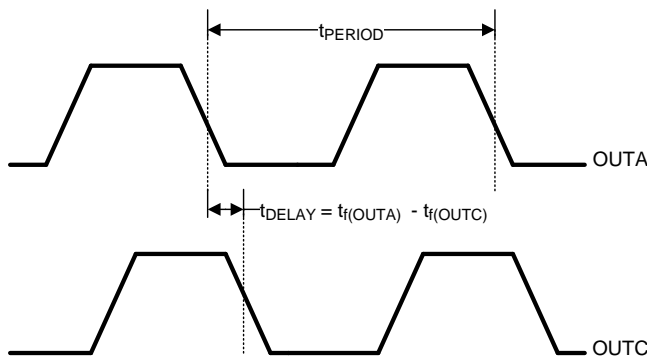

Figure 1. Same Applies to OUTB and OUTD

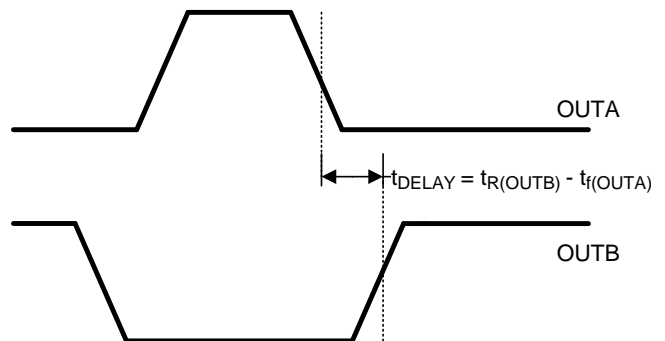
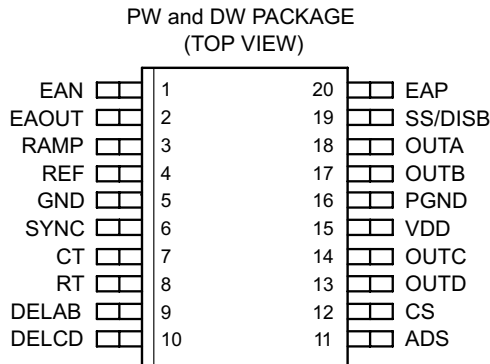

Figure 2. Same Applies to OUTC and OUTD

DEVICE INFORMATION

PW AND DW PACKAGE DRAWINGS (TOP VIEW)



N AND J PACKAGE DRAWINGS (TOP VIEW)

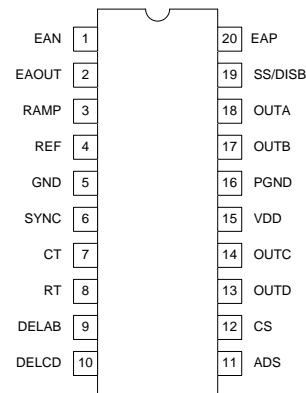

FN AND FK PACKAGE DRAWINGS (TOP VIEW)

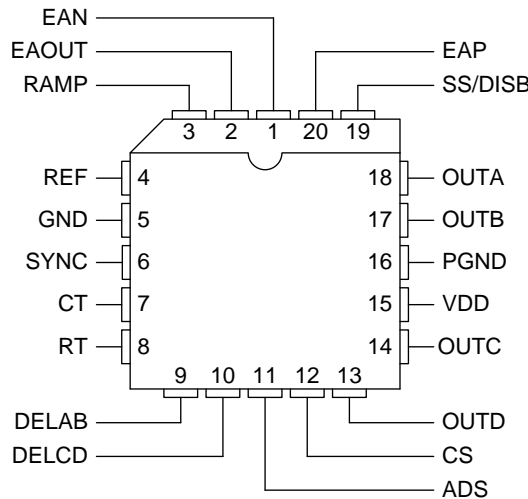

TERMINAL FUNCTIONS

TERMINAL		I/O	DESCRIPTION
NAME	NO.		
ADS	11	I	The adaptive-delay-set pin sets the ratio between the maximum and minimum programmed output delay dead time.
CS	12	I	Current sense input for cycle-by-cycle current limiting and for over-current comparator.
CT	7	I	Oscillator timing capacitor for programming the switching frequency. The UCC3895 oscillator charges CT via a programmed current.
DELAB	9	I	The delay-programming between complementary-outputs pin, DELAB, programs the dead time between switching of output A and output B.
DELCD	10	I	The delay-programming between complementary-outputs pin, DELCD, programs the dead time between switching of output C and output D.
EAOUT	2	I/O	Error amplifier output.
EAP	20	I	Non-inverting input to the error amplifier. Keep below 3.6 V for proper operation.
EAN	1	I	Inverting input to the error amplifier. Keep below 3.6 V for proper operation.
GND	5	-	Chip ground for all circuits except the output stages.

TERMINAL FUNCTIONS (continued)

TERMINAL		I/O	DESCRIPTION
NAME	NO.		
OUTA	18	O	The four outputs are 100-mA complementary MOS drivers, and are optimized to drive FET driver circuits such as UCC27424 or gate drive transformers.
OUTB	17	O	
OUTC	14	O	
OUTD	13	O	
PGND	16	-	Output stage ground.
RAMP	3	I	Inverting input of the PWM comparator.
REF	4	O	5 V, $\pm 1.2\%$, 5 mA voltage reference. For best performance, bypass with a 0.1- μF low ESR, low ESL capacitor to ground. Do not use more than 4.7 μF of total capacitance on this pin.
RT	8	I	Oscillator timing resistor for programming the switching frequency.
SS/DISB	19	I	Soft-start and disable pin which combines the two independent functions.
SYNC	6	I/O	The oscillator synchronization pin is bidirectional.
VDD	15	I	The power supply input pin, VDD, must be bypassed with a minimum of a 1- μF low ESR, low ESL capacitor to ground. The addition of a 10- μF low ESR, low ESL between VDD and PGND is recommended.

BLOCK DIAGRAM

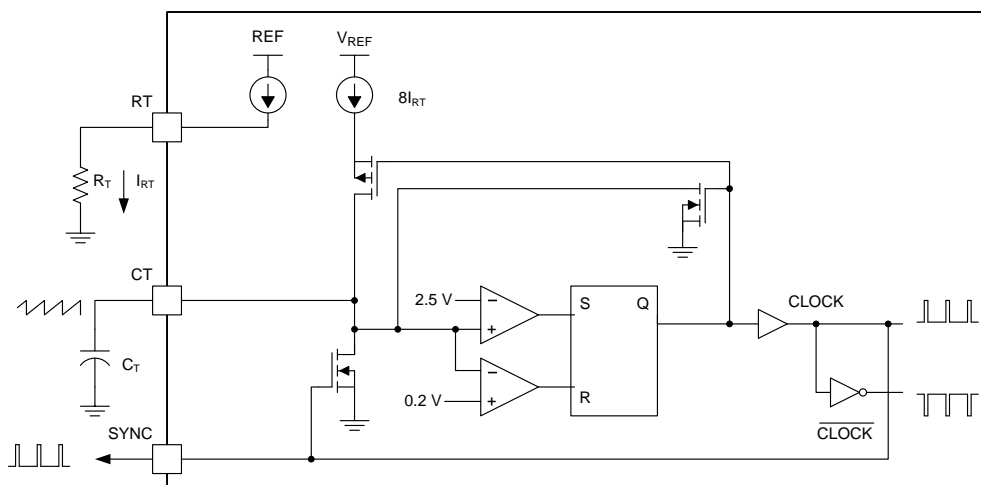
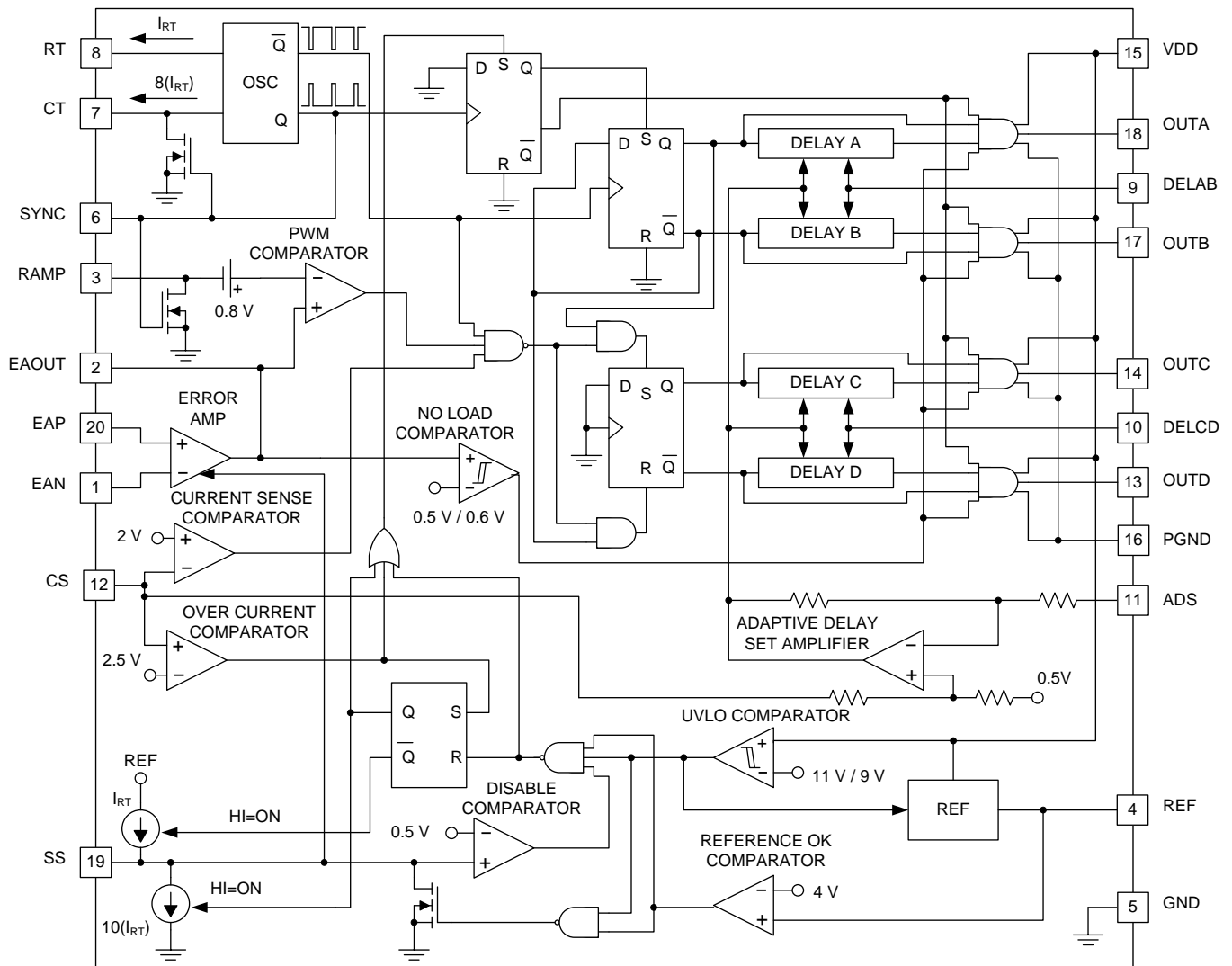

Figure 3. Oscillator Block Diagram

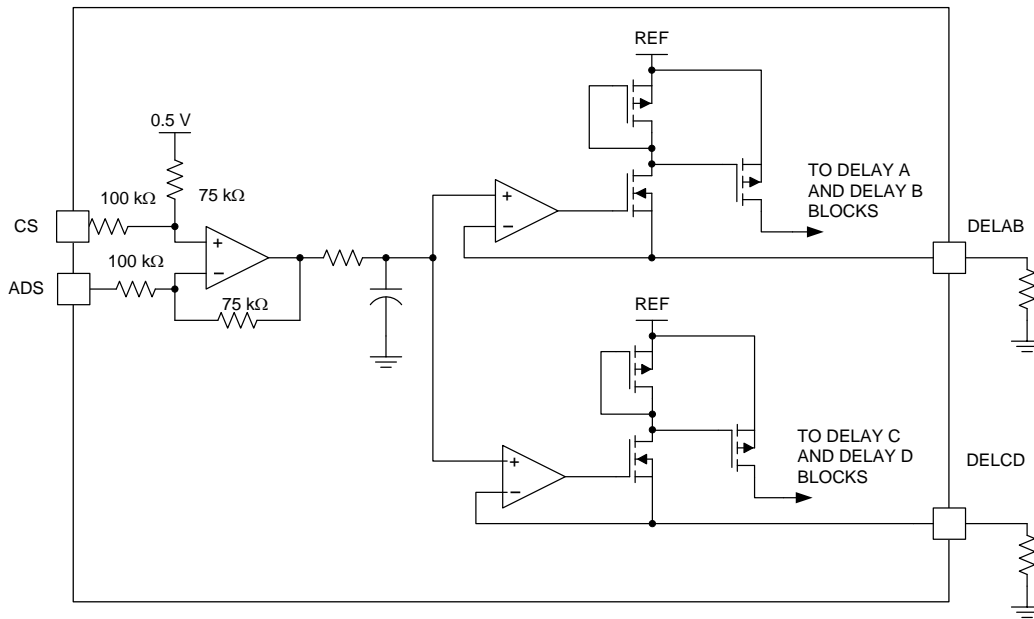

Figure 4. Adaptive Delay Set Block Diagram

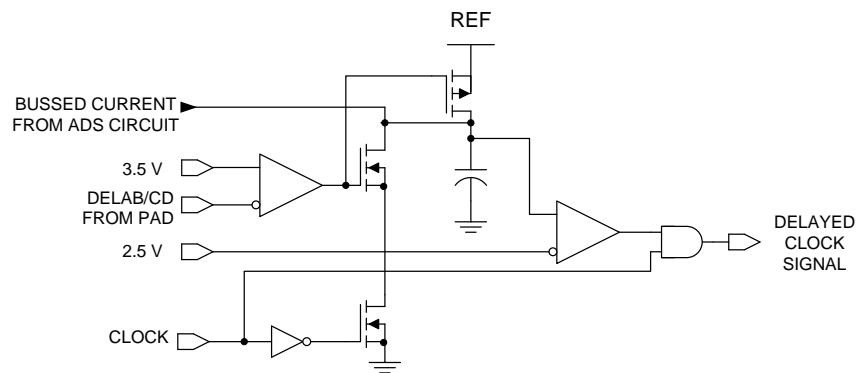

Figure 5. Delay Block Diagram (One Delay Block Per Outlet)

DETAILED PIN DESCRIPTION

ADS (Adaptive Delay Set)

This function sets the ratio between the maximum and minimum programmed output-delay dead time. When the ADS pin is directly connected to the CS pin, no delay modulation occurs. The maximum delay modulation occurs when ADS is grounded. In this case, delay time is four-times longer when CS = 0 than when CS = 2 V (the peak-current threshold), ADS changes the output voltage on the delay pins DELAB and DELCD by [Equation 1](#).

$$V_{\text{DEL}} = [0.75 \times (V_{\text{CS}} - V_{\text{ADS}})] + 0.5 \text{ V}$$

where

- V_{CS} and V_{ADS} are in volts (1)

ADS must be limited to between 0 V and 2.5 V and must be less-than or equal-to CS. DELAB and DELCD are clamped to a minimum of 0.5 V.

CS (Current Sense)

The CS input connects to the inverting input of the current-sense comparator and the non-inverting input of the overcurrent comparator and the ADS amplifier. The current sense signal is used for cycle-by-cycle current limiting in peak current-mode control, and for overcurrent protection in all cases with a secondary threshold for output shutdown. An output disable initiated by an overcurrent fault also results in a restart cycle, called soft-stop, with full soft-start.

CT (Oscillator Timing Capacitor)

The UCC3895 oscillator charges CT via a programmed current. The waveform on C_T is a sawtooth, with a peak voltage of 2.35 V. The approximate oscillator period is calculated by [Equation 2](#).

$$t_{\text{OSC}} = \frac{5 \times R_T \times C_T}{48} + 120 \text{ ns}$$

where

- C_T is in Farads
- R_T is in Ohms
- t_{OSC} is in seconds
- C_T can range from 100 to 880 pF. (2)

NOTE

A large C_T and a small R_T combination results in extended fall times on the C_T waveform. The increased fall time increases the SYNC pulse width, hence limiting the maximum phase shift between OUTA, OUTB and OUTC, OUTD outputs, which limits the maximum duty cycle of the converter (see to [Figure 3](#)).

DELAB and DELCD (Delay Programming Between Complementary Outputs)

DELAB programs the dead time between switching of OUTA and OUTB. DELCD programs the dead time between OUTC and OUTD. This delay is introduced between complementary outputs in the same leg of the external bridge. The UCC2895N allows the user to select the delay, in which the resonant switching of the external power stages takes place. Separate delays are provided for the two half-bridges to accommodate differences in resonant-capacitor charging currents. The delay in each stage is set according to [Equation 3](#).

$$t_{\text{DELAY}} = \frac{(25 \times 10^{-12}) \times R_{\text{DEL}}}{V_{\text{DEL}}} + 25 \text{ ns}$$

where

- V_{DEL} is in volts
- R_{DEL} is in Ohms
- t_{DELAY} is in seconds (3)

DELAB and DELCD source about 1 mA maximum. Choose the delay resistors so that this maximum is not exceeded. Programmable output delay is defeated by tying DELAB and, or, DELCD to REF. For an optimum performance keep stray capacitance on these pins at less than 10 pF.

EAOUT, EAP, and EAN (Error Amplifier)

EAOUT connects internally to the non-inverting input of the PWM comparator and the no-load comparator. EAOUT is internally clamped to the soft-start voltage. The no-load comparator shuts down the output stages when EAOUT falls below 500 mV, and allows the outputs to turn on again when EAOUT rises above 600 mV.

EAP is the non-inverting and the EAN is the inverting input to the error amplifier.

OUTA, OUTB, OUTC, and OUTD (Output MOSFET Drivers)

The four outputs are 100-mA complementary MOS drivers, and are optimized to drive MOSFET driver circuits. OUTA and OUTB are fully complementary, (assuming no programming delay) and operate near 50% duty cycle and one-half the oscillator frequency. OUTA and OUTB are intended to drive one half-bridge circuit in an external power stage. OUTC and OUTD drive the other half-bridge and have the same characteristics as OUTA and OUTB. OUTC is phase shifted with respect to OUTA, and OUTD is phase shifted with respect to OUTB.

NOTE

Changing the phase relationship of OUTC and OUTD with respect to OUTA and OUTB requires other than the nominal 50% duty ratio on OUTC and OUTD during those transients.

PGND (Power Ground)

To keep output switching noise from critical analog circuits, the UCC3895 has two different ground connections. PGND is the ground connection for the high-current output stages. Both GND and PGND must be electrically tied together. Also, because PGND carries high current, board traces must be low impedance.

RAMP (Inverting Input of the PWM Comparator)

This pin receives either the C_T waveform in voltage and average current-mode controls, or the current signal (plus slope compensation) in peak current-mode control.

REF (Voltage Reference)

The 5-V \pm 1.2% reference supplies power to internal circuitry, and also supplies up to 5 mA to external loads. The reference is shutdown during undervoltage lockout but is operational during all other disable modes. For best performance, bypass with a 0.1- μ F low-ESR low-ESL capacitor to GND. To ensure the stability of the internal reference, do not use more than 1.0 μ F of total capacitance on this pin for the UCC1895.

For the UCC2895 and the UCC3895, this capacitance increases as per the limits defined in the [RECOMMENDED OPERATING CONDITIONS](#) table of this specification.

RT (Oscillator Timing Resistor)

The oscillator in the UCC3895 operates by charging an external timing capacitor, C_T , with a fixed current programmed by R_T . R_T current is calculated with [Equation 4](#).

$$I_{RT} \text{ (A)} = \frac{3 \text{ V}}{R_T \text{ (\Omega)}} \quad (4)$$

R_T ranges from 40 to 120 k Ω . Soft-start charging and discharging currents are also programmed by I_{RT} (Refer to [Figure 3](#)).

GND (Analog Ground)

This pin is the chip ground for all internal circuits except the output stages.

SS/DISB (Soft-Start/Disable)

This pin combines two independent functions.

Disable Mode: A rapid shutdown of the chip is accomplished by externally forcing SS/DISB below 0.5 V, externally forcing REF below 4 V, or if VDD drops below the undervoltage lockout threshold. In the case of REF being pulled below 4 V or an undervoltage condition, SS/DISB is actively pulled to ground via an internal MOSFET switch.

If an overcurrent fault is sensed ($CS = 2.5\text{ V}$), a soft-stop is initiated. In this mode, SS/DISB sinks a constant current of $(10 \times I_{RT})$. The soft-stop continues until SS/DISB falls below 0.5 V. When any of these faults are detected, all outputs are forced to ground immediately.

NOTE

If SS/DISB is forced below 0.5 V, the pin starts to source current equal to I_{RT} . The only time the part switches into low I_{DD} current mode, though, is when the part is in undervoltage lockout.

Soft-start Mode: After a fault or disable condition has passed, VDD is above the start threshold, and, or, SS/DISB falls below 0.5 V during a soft-stop, SS/DISB switches to a soft-start mode. The pin then sources current, equal to I_{RT} . A user-selected resistor/capacitor combination on SS/DISB determines the soft start time constant.

NOTE

SS/DISB actively clamps the EAOUT pin voltage to approximately the SS/DISB pin voltage during both soft-start, soft-stop, and disable conditions.

SYNC (Oscillator Synchronization)

This pin is bidirectional (refer to [Figure 3](#)). When used as an output, SYNC is used as a clock, which is the same as the internal clock of the device. When used as an input, SYNC overrides the internal oscillator of the chip and acts as the clock signal. This bidirectional feature allows synchronization of multiple power supplies. Also, the SYNC signal internally discharge the C_T capacitor and any filter capacitors that are present on the RAMP pin. The internal SYNC circuitry is level sensitive, with an input-low threshold of 1.9 V, and an input-high threshold of 2.1 V. A resistor as small as 3.9 k Ω may be tied between SYNC and GND to reduce the sync pulse width.

VDD (Chip Supply)

This is the input pin to the chip. VDD must be bypassed with a minimum of 1- μF low ESR, low ESL capacitor to ground. The addition of a 10- μF low ESR, low ESL between VDD and PGND is recommended.

TYPICAL CHARACTERISTICS

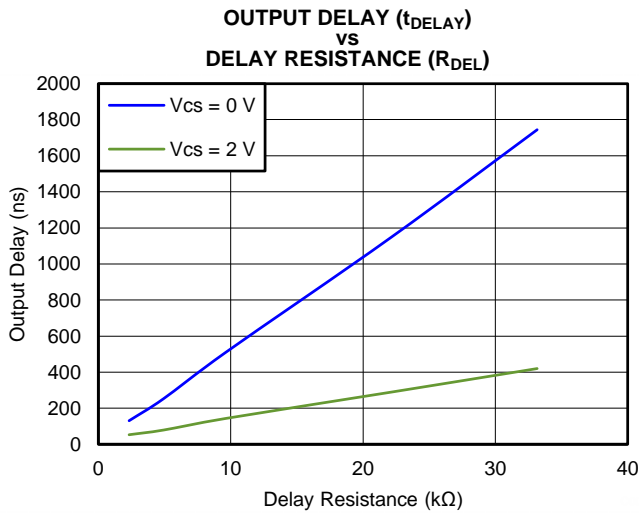

Figure 6.

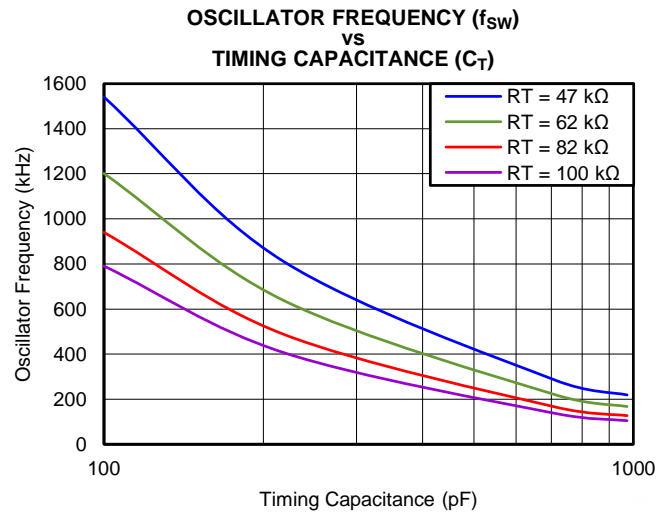

Figure 7.

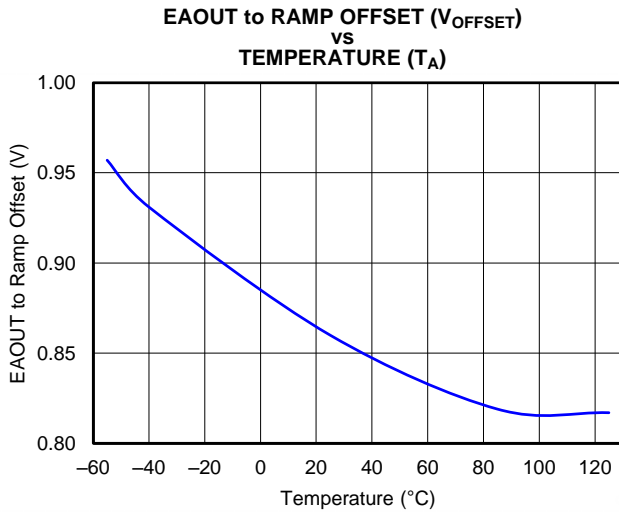

Figure 8.

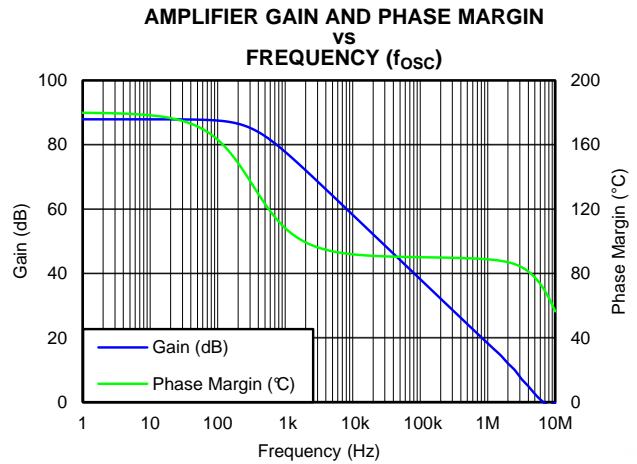

Figure 9.

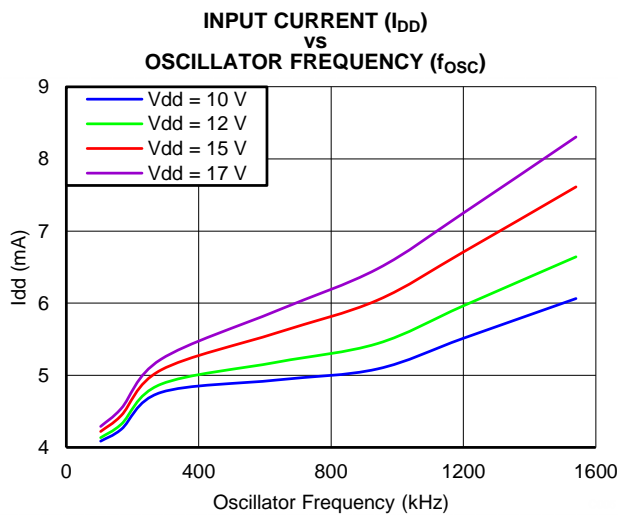

Figure 10.

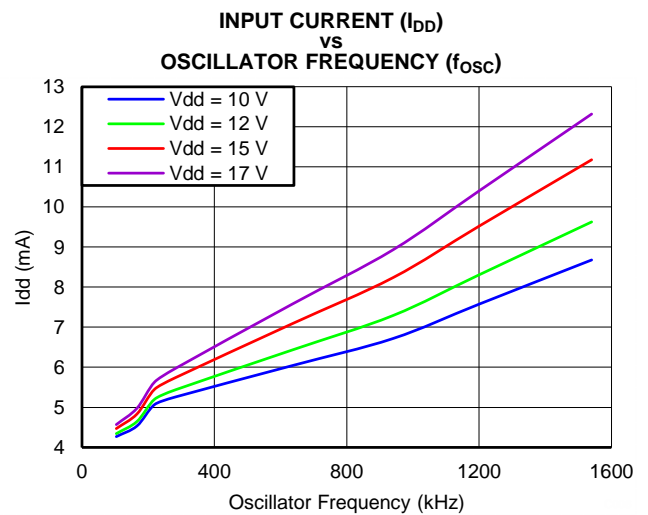

Figure 11.

APPLICATION INFORMATION

Programming DELAB, DELCD and the Adaptive Delay Set

The UCC2895N allows the user to set the delay between switch commands within each leg of the full-bridge power circuit according to Equation 5.

$$t_{\text{DELAY}} = \frac{(25 \times 10^{-12}) \times R_{\text{DEL}}}{V_{\text{DEL}}} + 25 \text{ NS} \quad (5)$$

From Equation 5 V_{DEL} is determined in conjunction with the desire to use (or not) the ADS feature from Equation 6.

$$V_{\text{DEL}} = [0.75 \times (V_{\text{CS}} - V_{\text{ADS}})] + 0.5 \text{ V} \quad (6)$$

Figure 12 illustrates the resistors needed to program the delay periods and the ADS function.

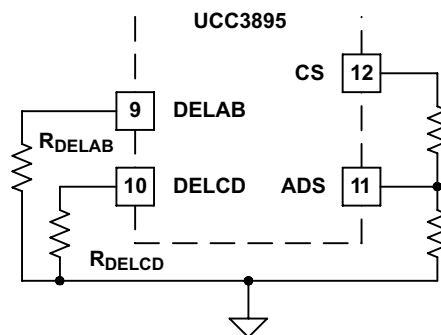

Figure 12. Programming Adaptive Delay Set

The ADS allows the user to vary the delay times between switch commands within each of the two legs of the converter. The delay-time modulation is implemented by connecting ADS (pin 11) to CS, GND, or a resistive divider from CS through ADS to GND to set V_{ADS} as shown in Figure 12. From Equation 6 for V_{DEL} , if ADS is tied to GND then V_{DEL} rises in direct proportion to V_{CS} , causing a decrease in t_{DELAY} as the load increases. In this condition, the maximum value of V_{DEL} is 2 V.

If ADS is connected to a resistive divider between CS and GND, the term $(V_{\text{CS}} - V_{\text{ADS}})$ becomes smaller, reducing the level of V_{DEL} . This reduction decreases the amount of delay modulation. In the limit of ADS tied to CS, $V_{\text{DEL}} = 0.5 \text{ V}$ and no delay modulation occurs. Figure 13 graphically shows the delay time versus load for varying adaptive delay set feature voltages (V_{ADS}).

In the case of maximum delay modulation (ADS = GND), when the circuit goes from light load to heavy load, the variation of V_{DEL} is from 0.5 to 2 V. This change causes the delay times to vary by a 4:1 ratio as the load is changed.

The ability to program an adaptive delay is a desirable feature because the optimum delay time is a function of the current flowing in the primary winding of the transformer, and changes by a factor of 10:1 or more as circuit loading changes. Reference 5 (see References) describes the many interrelated factors for choosing the optimum delay times for the most efficient power conversion, and illustrates an external circuit to enable ADS using the UC3879. Implementing this adaptive feature is simplified in the UCC3895 controller, giving the user the ability to tailor the delay times to suit a particular application with a minimum of external parts.

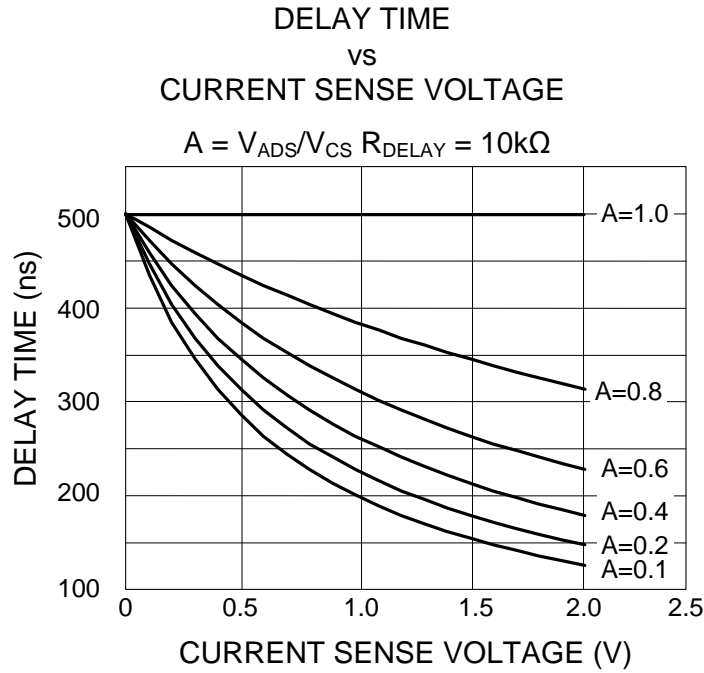
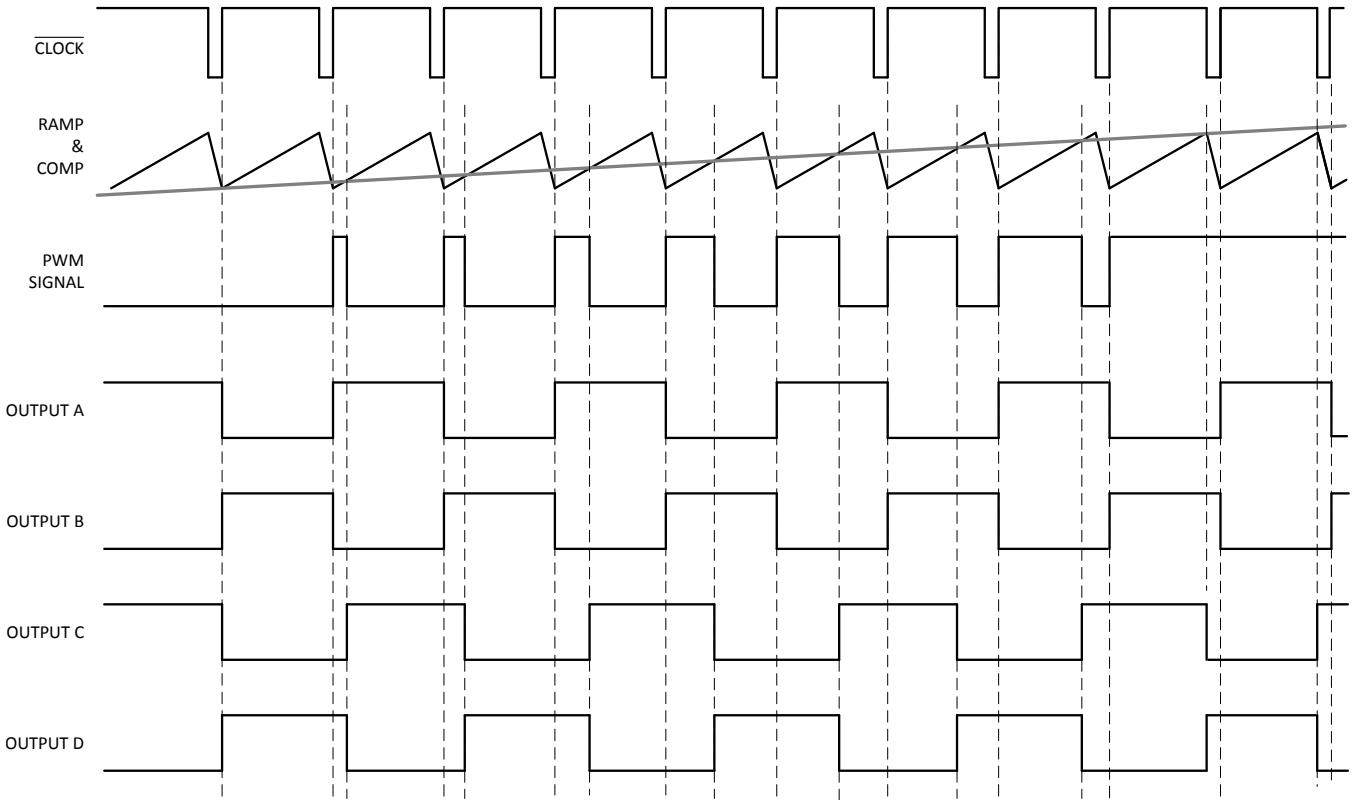

Figure 13. Delay Time Under Varying ADS Voltages



No Output Delay Shown, COMP to RAMP offset not included.

Figure 14. UCC3895 Timing Diagram

References

1. M. Dennis, *A Comparison Between the BiCMOS UCC3895 Phase Shift Controller and the UC3875*, Application Note ([SLUA246](#)).
2. L. Balogh, *The Current-Doubler Rectifier: An Alternative Rectification Technique for Push--Pull and Bridge Converters*, Application Note ([SLUA121](#)).
3. W. Andreyca, *Phase Shifted, Zero Voltage Transition Design Considerations*, Application Note ([SLUA107](#)).
4. L. Balogh, *The New UC3879 Phase Shifted PWM Controller Simplifies the Design of Zero Voltage Transition Full-Bridge Converters*, Application Note ([SLUA122](#)).
5. L. Balogh, *Design Review: 100 W, 400 kHz, dc-to-dc Converter with Current Doubler Synchronous Rectification Achieves 92% Efficiency*, Unitrode Power Supply Design Seminar Manual, SEM-1100, 1996, Topic 2.
6. *UC3875 Phase Shift Resonant Controller*, Datasheet ([SLUS229](#)).
7. *UC3879 Phase Shift Resonant Controller*, Datasheet ([SLUS230](#)).
8. UCC3895EVM--1, *Configuring the UCC3895 for direct Control Driven Synchronous Rectification* ([SLUU109](#)).
9. UCC3895, *CD Output Asymmetrical Duty Cycle Operation* ([SLUA275](#)).
10. Texas Instrument's Literature Number [SLUA323](#).
11. *Synchronous Rectifiers of a Current Doubler* ([SLUA287](#)).

REVISION HISTORY

Changes from Revision N (May 2009) to Revision O	Page
• Added thermal information table.	2
• Changed REF pin description from “Do not use more than 1.0 μ F of total capacitance on this pin.” to “Do not use more than 4.7 μ F of total capacitance on this pin.”	11
Changes from Revision O (April 2010) to Revision P	Page
• Changed Q package drawing to updated FN throughout	2
• Changed L package drawing to updated FK throughout and corresponding package type from CLCC to updated LCCC throughout	2
• Added <i>The CS input connects to</i> text to the beginning of the CS Detailed Pin Description	10
• Added second paragraph to detailed REF Pin Description and included the UCC1895 at the end of the first paragraph to differentiate capacitance capabilities of the devices.	11
• Changed <i>UCC3895 Timing Diagram</i> in the Application Information section to reflect the maximum duty cycle conditions	15

PACKAGING INFORMATION

Orderable Device	Status (1)	Package Type	Package Drawing	Pins	Package Qty	Eco Plan (2)	Lead/Ball Finish (6)	MSL Peak Temp (3)	Op Temp (°C)	Device Marking (4/5)	Samples
UCC1895J	ACTIVE	CDIP	J	20	1	TBD	A42	N / A for Pkg Type	-55 to 125	UCC1895J	Samples
UCC1895L	ACTIVE	LCCC	FK	20	1	TBD	POST-PLATE	N / A for Pkg Type	-55 to 125	UCC1895L	Samples
UCC2895DW	ACTIVE	SOIC	DW	20	25	Green (RoHS & no Sb/Br)	CU NIPDAU	Level-2-260C-1 YEAR	-40 to 85	UCC2895DW	Samples
UCC2895DWG4	ACTIVE	SOIC	DW	20	25	Green (RoHS & no Sb/Br)	CU NIPDAU	Level-2-260C-1 YEAR	-40 to 85	UCC2895DW	Samples
UCC2895DWTR	ACTIVE	SOIC	DW	20	2000	Green (RoHS & no Sb/Br)	CU NIPDAU	Level-2-260C-1 YEAR	-40 to 85	UCC2895DW	Samples
UCC2895DWTRG4	ACTIVE	SOIC	DW	20	2000	Green (RoHS & no Sb/Br)	CU NIPDAU	Level-2-260C-1 YEAR	-40 to 85	UCC2895DW	Samples
UCC2895N	ACTIVE	PDIP	N	20	18	Green (RoHS & no Sb/Br)	CU NIPDAU	N / A for Pkg Type	-40 to 85	UCC2895N	Samples
UCC2895PW	ACTIVE	TSSOP	PW	20	70	Green (RoHS & no Sb/Br)	CU NIPDAU	Level-2-260C-1 YEAR	-40 to 85	UCC2895	Samples
UCC2895PWTR	ACTIVE	TSSOP	PW	20	2000	Green (RoHS & no Sb/Br)	CU NIPDAU	Level-2-260C-1 YEAR	-40 to 85	UCC2895	Samples
UCC3895DW	ACTIVE	SOIC	DW	20	25	Green (RoHS & no Sb/Br)	CU NIPDAU	Level-2-260C-1 YEAR	0 to 70	UCC3895DW	Samples
UCC3895DWG4	ACTIVE	SOIC	DW	20	25	Green (RoHS & no Sb/Br)	CU NIPDAU	Level-2-260C-1 YEAR	0 to 70	UCC3895DW	Samples
UCC3895DWTR	ACTIVE	SOIC	DW	20	2000	Green (RoHS & no Sb/Br)	CU NIPDAU	Level-2-260C-1 YEAR	0 to 70	UCC3895DW	Samples
UCC3895DWTRG4	ACTIVE	SOIC	DW	20	2000	Green (RoHS & no Sb/Br)	CU NIPDAU	Level-2-260C-1 YEAR	0 to 70	UCC3895DW	Samples
UCC3895N	ACTIVE	PDIP	N	20	18	Green (RoHS & no Sb/Br)	CU NIPDAU	N / A for Pkg Type	0 to 70	UCC3895N	Samples
UCC3895NG4	ACTIVE	PDIP	N	20	18	Green (RoHS & no Sb/Br)	CU NIPDAU	N / A for Pkg Type	0 to 70	UCC3895N	Samples
UCC3895PW	ACTIVE	TSSOP	PW	20	70	Green (RoHS & no Sb/Br)	CU NIPDAU	Level-2-260C-1 YEAR	0 to 70	UCC3895	Samples
UCC3895PWTR	ACTIVE	TSSOP	PW	20	2000	Green (RoHS & no Sb/Br)	CU NIPDAU	Level-2-260C-1 YEAR	0 to 70	UCC3895	Samples

Orderable Device	Status (1)	Package Type	Package Drawing	Pins	Package Qty	Eco Plan (2)	Lead/Ball Finish (6)	MSL Peak Temp (3)	Op Temp (°C)	Device Marking (4/5)	Samples
UCC3895PWTRG4	ACTIVE	TSSOP	PW	20	2000	Green (RoHS & no Sb/Br)	CU NIPDAU	Level-2-260C-1 YEAR	0 to 70	UCC3895	Samples

(1) The marketing status values are defined as follows:

ACTIVE: Product device recommended for new designs.

LIFEBUY: TI has announced that the device will be discontinued, and a lifetime-buy period is in effect.

NRND: Not recommended for new designs. Device is in production to support existing customers, but TI does not recommend using this part in a new design.

PREVIEW: Device has been announced but is not in production. Samples may or may not be available.

OBSOLETE: TI has discontinued the production of the device.

(2) **RoHS:** TI defines "RoHS" to mean semiconductor products that are compliant with the current EU RoHS requirements for all 10 RoHS substances, including the requirement that RoHS substance do not exceed 0.1% by weight in homogeneous materials. Where designed to be soldered at high temperatures, "RoHS" products are suitable for use in specified lead-free processes. TI may reference these types of products as "Pb-Free".

RoHS Exempt: TI defines "RoHS Exempt" to mean products that contain lead but are compliant with EU RoHS pursuant to a specific EU RoHS exemption.

Green: TI defines "Green" to mean the content of Chlorine (Cl) and Bromine (Br) based flame retardants meet JS709B low halogen requirements of <=1000ppm threshold. Antimony trioxide based flame retardants must also meet the <=1000ppm threshold requirement.

(3) MSL, Peak Temp. - The Moisture Sensitivity Level rating according to the JEDEC industry standard classifications, and peak solder temperature.

(4) There may be additional marking, which relates to the logo, the lot trace code information, or the environmental category on the device.

(5) Multiple Device Markings will be inside parentheses. Only one Device Marking contained in parentheses and separated by a "~" will appear on a device. If a line is indented then it is a continuation of the previous line and the two combined represent the entire Device Marking for that device.

(6) Lead/Ball Finish - Orderable Devices may have multiple material finish options. Finish options are separated by a vertical ruled line. Lead/Ball Finish values may wrap to two lines if the finish value exceeds the maximum column width.

Important Information and Disclaimer:The information provided on this page represents TI's knowledge and belief as of the date that it is provided. TI bases its knowledge and belief on information provided by third parties, and makes no representation or warranty as to the accuracy of such information. Efforts are underway to better integrate information from third parties. TI has taken and continues to take reasonable steps to provide representative and accurate information but may not have conducted destructive testing or chemical analysis on incoming materials and chemicals. TI and TI suppliers consider certain information to be proprietary, and thus CAS numbers and other limited information may not be available for release.

In no event shall TI's liability arising out of such information exceed the total purchase price of the TI part(s) at issue in this document sold by TI to Customer on an annual basis.

OTHER QUALIFIED VERSIONS OF UCC1895, UCC2895, UCC3895 :

- Catalog: [UCC3895](#)

- Automotive: [UCC2895-Q1](#)
- Enhanced Product: [UCC2895-EP](#)
- Military: [UCC1895](#)

NOTE: Qualified Version Definitions:

- Catalog - TI's standard catalog product
- Automotive - Q100 devices qualified for high-reliability automotive applications targeting zero defects
- Enhanced Product - Supports Defense, Aerospace and Medical Applications
- Military - QML certified for Military and Defense Applications

TAPE AND REEL INFORMATION

QUADRANT ASSIGNMENTS FOR PIN 1 ORIENTATION IN TAPE

*All dimensions are nominal

Device	Package Type	Package Drawing	Pins	SPQ	Reel Diameter (mm)	Reel Width W1 (mm)	A0 (mm)	B0 (mm)	K0 (mm)	P1 (mm)	W (mm)	Pin1 Quadrant
UCC2895PWTR	TSSOP	PW	20	2000	330.0	16.4	6.95	7.1	1.6	8.0	16.0	Q1
UCC3895DWTR	SOIC	DW	20	2000	330.0	24.4	10.8	13.3	2.7	12.0	24.0	Q1

TAPE AND REEL BOX DIMENSIONS

*All dimensions are nominal

Device	Package Type	Package Drawing	Pins	SPQ	Length (mm)	Width (mm)	Height (mm)
UCC2895PWTR	TSSOP	PW	20	2000	367.0	367.0	38.0
UCC3895DWTR	SOIC	DW	20	2000	350.0	350.0	43.0

J (R-GDIP-T**)

14 LEADS SHOWN

CERAMIC DUAL IN-LINE PACKAGE



DIM \ PINS **	14	16	18	20
A	0.300 (7,62) BSC	0.300 (7,62) BSC	0.300 (7,62) BSC	0.300 (7,62) BSC
B MAX	0.785 (19,94)	.840 (21,34)	0.960 (24,38)	1.060 (26,92)
B MIN	—	—	—	—
C MAX	0.300 (7,62)	0.300 (7,62)	0.310 (7,87)	0.300 (7,62)
C MIN	0.245 (6,22)	0.245 (6,22)	0.220 (5,59)	0.245 (6,22)



4040083/F 03/03

- NOTES:
- All linear dimensions are in inches (millimeters).
 - This drawing is subject to change without notice.
 - This package is hermetically sealed with a ceramic lid using glass frit.
 - Index point is provided on cap for terminal identification only on press ceramic glass frit seal only.
 - Falls within MIL STD 1835 GDIP1-T14, GDIP1-T16, GDIP1-T18 and GDIP1-T20.

PW (R-PDSO-G20)

PLASTIC SMALL OUTLINE



- NOTES:
- A. All linear dimensions are in millimeters.
 - B. This drawing is subject to change without notice.
 - C. Publication IPC-7351 is recommended for alternate design.
 - D. Laser cutting apertures with trapezoidal walls and also rounding corners will offer better paste release. Customers should contact their board assembly site for stencil design recommendations. Refer to IPC-7525 for other stencil recommendations.
 - E. Customers should contact their board fabrication site for solder mask tolerances between and around signal pads.

N (R-PDIP-T**)

PLASTIC DUAL-IN-LINE PACKAGE

16 PINS SHOWN



4040049/E 12/2002

- NOTES:
- A. All linear dimensions are in inches (millimeters).
 - B. This drawing is subject to change without notice.
 - $\triangle C$ Falls within JEDEC MS-001, except 18 and 20 pin minimum body length (Dim A).
 - $\triangle D$ The 20 pin end lead shoulder width is a vendor option, either half or full width.

DW0020A



PACKAGE OUTLINE

SOIC - 2.65 mm max height

SOIC



4220724/A 05/2016

NOTES:

1. All linear dimensions are in millimeters. Dimensions in parenthesis are for reference only. Dimensioning and tolerancing per ASME Y14.5M.
2. This drawing is subject to change without notice.
3. This dimension does not include mold flash, protrusions, or gate burrs. Mold flash, protrusions, or gate burrs shall not exceed 0.15 mm per side.
4. This dimension does not include interlead flash. Interlead flash shall not exceed 0.43 mm per side.
5. Reference JEDEC registration MS-013.

EXAMPLE BOARD LAYOUT

DW0020A

SOIC - 2.65 mm max height

SOIC



LAND PATTERN EXAMPLE
SCALE:6X



SOLDER MASK DETAILS

4220724/A 05/2016

NOTES: (continued)

- 6. Publication IPC-7351 may have alternate designs.
- 7. Solder mask tolerances between and around signal pads can vary based on board fabrication site.

EXAMPLE STENCIL DESIGN

DW0020A

SOIC - 2.65 mm max height

SOIC



SOLDER PASTE EXAMPLE
BASED ON 0.125 mm THICK STENCIL
SCALE:6X

4220724/A 05/2016

NOTES: (continued)

- 8. Laser cutting apertures with trapezoidal walls and rounded corners may offer better paste release. IPC-7525 may have alternate design recommendations.
- 9. Board assembly site may have different recommendations for stencil design.

FK (S-CQCC-N**)

LEADLESS CERAMIC CHIP CARRIER

28 TERMINAL SHOWN



NO. OF TERMINALS **	A		B	
	MIN	MAX	MIN	MAX
20	0.342 (8,69)	0.358 (9,09)	0.307 (7,80)	0.358 (9,09)
28	0.442 (11,23)	0.458 (11,63)	0.406 (10,31)	0.458 (11,63)
44	0.640 (16,26)	0.660 (16,76)	0.495 (12,58)	0.560 (14,22)
52	0.740 (18,78)	0.761 (19,32)	0.495 (12,58)	0.560 (14,22)
68	0.938 (23,83)	0.962 (24,43)	0.850 (21,6)	0.858 (21,8)
84	1.141 (28,99)	1.165 (29,59)	1.047 (26,6)	1.063 (27,0)



4040140/D 01/11

- NOTES:
- All linear dimensions are in inches (millimeters).
 - This drawing is subject to change without notice.
 - This package can be hermetically sealed with a metal lid.
 - Falls within JEDEC MS-004

IMPORTANT NOTICE AND DISCLAIMER

TI PROVIDES TECHNICAL AND RELIABILITY DATA (INCLUDING DATASHEETS), DESIGN RESOURCES (INCLUDING REFERENCE DESIGNS), APPLICATION OR OTHER DESIGN ADVICE, WEB TOOLS, SAFETY INFORMATION, AND OTHER RESOURCES "AS IS" AND WITH ALL FAULTS, AND DISCLAIMS ALL WARRANTIES, EXPRESS AND IMPLIED, INCLUDING WITHOUT LIMITATION ANY IMPLIED WARRANTIES OF MERCHANTABILITY, FITNESS FOR A PARTICULAR PURPOSE OR NON-INFRINGEMENT OF THIRD PARTY INTELLECTUAL PROPERTY RIGHTS.

These resources are intended for skilled developers designing with TI products. You are solely responsible for (1) selecting the appropriate TI products for your application, (2) designing, validating and testing your application, and (3) ensuring your application meets applicable standards, and any other safety, security, or other requirements. These resources are subject to change without notice. TI grants you permission to use these resources only for development of an application that uses the TI products described in the resource. Other reproduction and display of these resources is prohibited. No license is granted to any other TI intellectual property right or to any third party intellectual property right. TI disclaims responsibility for, and you will fully indemnify TI and its representatives against, any claims, damages, costs, losses, and liabilities arising out of your use of these resources.

TI's products are provided subject to TI's Terms of Sale (www.ti.com/legal/termsofsale.html) or other applicable terms available either on ti.com or provided in conjunction with such TI products. TI's provision of these resources does not expand or otherwise alter TI's applicable warranties or warranty disclaimers for TI products.

Mailing Address: Texas Instruments, Post Office Box 655303, Dallas, Texas 75265
Copyright © 2019, Texas Instruments Incorporated

Looking for pricing, stock, or lifecycle information?

Click below to explore more details on WIN SOURCE:

 [View UCC2895PW](#) on WIN SOURCE

 [Texas Instruments](#) Information

Optimize Your Supply Chain with WIN SOURCE Solutions

-  Global Sourcing Solution
-  Obsolete Management
-  Cost Control Management
-  Shortage Management
-  Alternative Solution
-  Excess Inventory Management