

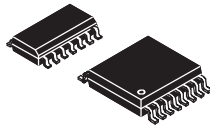

**THE DATASHEET OF
UC3854ADW**





ADVANCED HIGH-POWER FACTOR PREREGULATOR

FEATURES

- Controls Boost PWM to Near-Unity Power Factor
- Limits Line Current Distortion To <3%
- World-Wide Operation Without Switches
- Accurate Power Limiting
- Fixed-Frequency Average Current-Mode Control
- High Bandwidth (5 MHz), Low-Offset Current Amplifier
- Integrated Current- and Voltage-Amplifier Output Clamps
- Multiplier Improvements: Linearity, 500 mV V_{AC} Offset (Eliminates External Resistor), 0 V to 5 V Multout Common-Mode Range
- V_{REF} GOOD Comparator
- Faster and Improved Accuracy ENABLE Comparator
- UVLO Options (16 V/10 V or 10.5 V/10 V)
- 300- μ A Start-Up Supply Current

DESCRIPTION

The UC3854A/B products are pin compatible enhanced versions of the UC3854. Like the UC3854, these products provide all of the functions necessary for active power factor corrected preregulators. The controller achieves near unity power factor by shaping the ac input line current waveform to correspond to the ac input line voltage. To do this the UC3854A/B uses average current mode control. Average current mode control maintains stable, low distortion sinusoidal line current without the need for slope compensation, unlike peak current mode control.

A 1%, 7.5-V reference, fixed frequency oscillator, PWM, voltage amplifier with soft-start, line voltage feedforward (V_{RMS} squarer), input supply voltage clamp, and over current comparator round out the list of features.

Available in the 16-pin N (PDIP), DW (SOIC Wide), and J (CDIP) and 20-pin Q (PLCC) package. See Ordering Information table for availability by temperature range.

BLOCK DIAGRAM

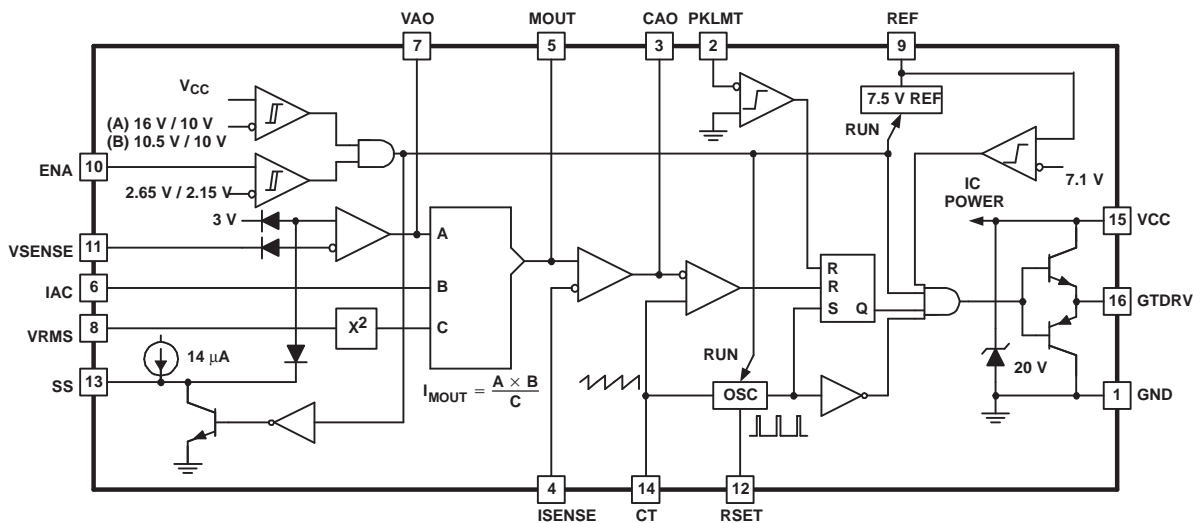

Please be aware that an important notice concerning availability, standard warranty, and use in critical applications of Texas Instruments semiconductor products and disclaimers thereto appears at the end of this data sheet.



These devices have limited built-in ESD protection. The leads should be shorted together or the device placed in conductive foam during storage or handling to prevent electrostatic damage to the MOS gates.

DESCRIPTION (CONTINUED)

The UC3854A/B products improve upon the UC3854 by offering a wide bandwidth, low offset current amplifier, a faster responding and improved accuracy enable comparator, a VREF GOOD comparator, UVLO threshold options (16 V/10 V for offline, 10.5 V/10 V for startup from an auxiliary 12-V regulator), lower startup supply current, and an enhanced multiply/divide circuit. New features like the amplifier output clamps, improved amplifier current sinking capability, and low offset VAC pin reduce the external component count while improving performance. Improved common mode input range of the multiplier output/current amplifier input allow the designer greater flexibility in choosing a method for current sensing. Unlike its predecessor, R_{SET} controls only oscillator charging current and has no effect on clamping the maximum multiplier output current. This current is now clamped to a maximum of $2 \times I_{AC}$ at all times which simplifies the design process and provides foldback power limiting during brownout and extreme low line conditions.

ORDERING INFORMATION

T_A	UVLO TURN-ON (V)	UVLO TURN-OFF (V)	PART NUMBERS			
			CDIP-16 (V)	PDIP-16 (N)	SOIC-16 (DW)	PLCC-20 (Q)
–55°C to 125°C	16	10	–	–	–	–
	10.5	10	UC1854BJ	–	–	–
–40°C to 85°C	16	10	UC2854AJ	UC2854AN	UC2854ADW	UC2854AQ
	10.5	10	UC2854BJ	UC2854BN	UC2854BDW	UC2854BQ
0°C to 70°C	16	10	–	UC2854AN	UC2854ADW	–
	10.5	10	–	UC2854BN	UC2854BDW	–

ABSOLUTE MAXIMUM RATINGS

over operating free-air temperature range (unless otherwise noted)⁽¹⁾

		UCX854A, UCX854B	UNIT
V_{CC}	Supply voltage	22	V
I_{GTDRV}	GTDRV current	Continuous	0.5
		50% duty cycle	1.5
Input voltage	VSENSE, VRMS, ISENSE MOUT	11	V
	PKLMT	5	
Input current	RSET, IAC, PKLMT, ENA	10	mA
Power dissipation		1	W
T_J	Junction temperature	–55 to 150	°C
T_{stg}	Storage temperature	–65 to 150	
T_{sol}	Lead temperature, 1,6 mm (1/16 inch) from case for 10 seconds	300	

- (1) Stresses beyond those listed under *absolutemaximum ratings* may cause permanent damage to the device. These are stress ratings only, and functional operation of the device at these or any other conditions beyond those indicated under *recommended operating conditions* is not implied. Exposure to absolute-maximum-rated conditions for extended periods may affect device reliability. All voltages are with respect to GND. Currents are positive into and negative out of, the specified terminal. ENA input is internally clamped to approximately 10 V.

RECOMMENDED OPERATING CONDITIONS

over operating free-air temperature range (unless otherwise noted)

			MIN	MAX	UNIT
V _{CC}	Supply voltage		10	20	V
T _J	Operating junction temperature	UC1854X	-55	125	°C
		UC2854X	-40	85	
		UC3854X	0	70	

THERMAL RESISTANCE

RESISTANCES	PACKAGED DEVICES			
	CDIP-16 (J)	PDIP-16 (N)	SOP-16 (DW)	PLCC-20 (Q)
θ_{JC} (°C/W)	28 ⁽¹⁾	45	27	34
θ_{JA} (°C/W)	80–120	90 ⁽²⁾	50–130 ⁽²⁾	43–75 ⁽²⁾

- θ_{JC} data values stated are derived from MIL-STD-1835B which states the baseline values shown are worst case (mean +2s) for a 60 × 60 mil microcircuit device silicon die and applicable for devices with die sizes up to 14,400 square mils. For device die sizes greater than 14,400 square mils use the following values, dual-in-line, 11°C/W; flat pack and pin grid array, 10°C/W. are at the end of each trace.
- θ_{JA} (junction-to-ambient) applies to devices mounted to five square inch FR4 PC board with one ounce copper where noted. When resistance range is given, lower values are for five square inch aluminum PC board. Test PWB is 0.062 inches thick and typically uses 0,635 mm trace widths for power packages and 1,3 mm trace widths for non-power packages with a 100 × 100 mil probe land are at the end of each trace.

ELECTRICAL CHARACTERISTICS

$V_{CC} = 18\text{ V}$, $R_T = 8.2\text{ k}\Omega$, $C_T = 1.5\text{ nF}$, $V_{PKLMT} = 1\text{ V}$, $V_{VRMS} = 1.5\text{ V}$, $I_{IAC} = 100\text{ }\mu\text{A}$, $I_{ISENSE} = 0\text{ V}$, $V_{CAO} = 3.5\text{ V}$, $V_{VAO} = 5\text{ V}$, $V_{VSENSE} = 3\text{ V}$, $-40^\circ\text{C} < T_A < 85^\circ\text{C}$ for the UC2854A and UC2854B, and $0^\circ\text{C} < T_A < 70^\circ\text{C}$ for the UC3854A and UC3854B, and $T_A = T_J$ (unless otherwise noted)

PARAMETER		TEST CONDITIONS	MIN	TYP	MAX	UNIT
OVERALL						
Supply current, off		$CAO = 0\text{ V}$, $VAO = 0\text{ V}$, $V_{CC} = V_{UVLO} - 0.3\text{ V}$		250	400	μA
Supply current, on				12	18	mA
V_{CC} turn-on threshold voltage	UCx854A		15.0	16.0	17.5	V
	UCx854B		8.0	10.5	11.2	
V_{CC} turn-off threshold voltage	UCx854A		9	10	12	
	UCx854B		7.8	10.3	11.0	
V_{CC} hysteresis	UCx854A		5	6	7	
	UCx854B		0.10	0.22	0.50	
V_{CC} clamp		$I_{VCC} = I_{VCC(on)} + 5\text{ mA}$	18	20	22	
VOLTAGE AMPLIFIER						
Input voltage			2.9	3.0	3.1	V
V_{SENSE} bias current			-500	-25	500	nA
Open loop gain		$2\text{ V} \leq V_{OUT} \leq 5\text{ V}$	70	100		dB
V_{OH} High-level output voltage		$I_{LOAD} = -500\text{ }\mu\text{A}$		6		V
V_{OL} Low-level output voltage		$I_{LOAD} = 500\text{ }\mu\text{A}$		0.3	0.5	
I_{SC} Output short-circuit current		$V_{OUT} = 0\text{ V}$		1.5	3.5	mA
Gain bandwidth product ⁽¹⁾		$f_{IN} = 100\text{ kHz}$, 10 mVp-p		1		MHz
CURRENT AMPLIFIER						
Input offset voltage		$V_{CM} = 0\text{ V}$, $T_A = 25^\circ\text{C}$	-4		0	mV
		$V_{CM} = 0\text{ V}$, Overtemperature	-5.5		0	
I_{SENSE} Input bias current		$V_{CM} = 0\text{ V}$	-500		500	nA
Open loop gain		$2\text{ V} \leq V_{OUT} = 6\text{ V}$	80	110		dB
V_{OH} High-level output voltage		$I_{LOAD} = -500\text{ }\mu\text{A}$		8		V
V_{OL} Low-level output voltage		$I_{LOAD} = 500\text{ }\mu\text{A}$		0.3	0.5	
I_{SC} Output short-circuit current		$V_{OUT} = 0\text{ V}$		1.5	3.5	mA
CMRR Common mode rejection range			-0.3		5.0	V
Gain bandwidth product ⁽¹⁾		$f_{IN} = 100\text{ kHz}$, 10 mVp-p	3	5		MHz
REFERENCE						
Output voltage		$I_{REF} = 0\text{ mA}$, $T_A = 25^\circ\text{C}$	7.4	7.5	7.6	V
		$I_{REF} = 0\text{ mA}$	7.35	7.50	7.65	
Load regulation		$1\text{ mA} \leq I_{REF} \leq 10\text{ mA}$	0	8	20	mV
Line regulation		$12\text{ V} \leq V_{CC} \leq 18\text{ V}$	0	14	25	
I_{SC} Short circuit current		$V_{REF} = 0\text{ V}$	25	35	60	mA

(1) Ensured by design. Not production tested.

ELECTRICAL CHARACTERISTICS (Continued)

$V_{CC} = 18\text{ V}$, $R_T = 8.2\text{ k}\Omega$, $C_T = 1.5\text{ nF}$, $V_{PKLMT} = 1\text{ V}$, $V_{VRMS} = 1.5\text{ V}$, $I_{IAC} = 100\text{ }\mu\text{A}$, $I_{ISENSE} = 0\text{ V}$, $V_{CAO} = 3.5\text{ V}$, $V_{VAO} = 5\text{ V}$, $V_{VSENSE} = 3\text{ V}$, $-40^\circ\text{C} < T_A < 85^\circ\text{C}$ for the UC2854A and UC2854B, and $0^\circ\text{C} < T_A < 70^\circ\text{C}$ for the UC3854A and UC3854B, and $T_A = T_J$ (unless otherwise noted)

PARAMETER	TEST CONDITIONS	MIN	TYP	MAX	UNIT
OSCILLATOR					
Initial accuracy	$T_A = 25^\circ\text{C}$	85	100	115	kHz
Voltage stability	$12\text{ V} \leq V_{CC} \leq 18\text{ V}$		1%		
Total variation	Line, temperature	80		120	kHz
Ramp amplitude (peak-to-peak)		4.9		5.9	V
Ramp valley voltage		0.8		1.3	V
ENABLE/SOFT-START/CURRENT LIMIT					
Enable threshold voltage		2.35	2.55	2.80	V
Enable hysteresis	$V_{FAULT} = 2.5\text{ V}$		500	600	mV
Enable input bias current	$V_{ENA} = 0\text{ V}$		-2	-5	μA
Propagation delay to disable time ⁽¹⁾	Enable overdrive = 100 mV		300		ns
Soft-start charge current	$V_{SS} = 2.5\text{ V}$	10	14	24	μA
Peak limit offset voltage		-15		15	mV
Peak limit offset current	$V_{PKLMT} = -0.1\text{ V}$	-200	-100		μA
Peak limit propagation delay time ⁽¹⁾			150		ns
MULTIPLIER					
Output current, I_A limited	$I_{IAC} = 100\text{ }\mu\text{A}$, $R_{SET} = 10\text{ k}\Omega$	$V_{RMS} = 1\text{ V}$,			
			-220	-200	-170
Output current, zero	$I_{IAC} = 0\text{ }\mu\text{A}$,	$R_{SET} = 10\text{ k}\Omega$			
			-2.0	-0.2	2.0
Output current, power limited	$V_{RMS} = 1.5\text{ V}$	$V_a = 6\text{ V}$			
			-230	-200	-170
Output current	$V_{RMS} = 1.5\text{ V}$	$V_a = 2\text{ V}$			
					-22
	$V_{RMS} = 1.5\text{ V}$	$V_a = 5\text{ V}$			
					-156
	$V_{RMS} = 5\text{ V}$	$V_a = 2\text{ V}$			
					-2
	$V_{RMS} = 5\text{ V}$	$V_a = 5\text{ V}$			
					-14
Gain constant ⁽²⁾	$V_{RMS} = 1.5\text{ V}$	$V_a = 6\text{ V}$, $T_A = 25^\circ\text{C}$			
			-1.1	-1.0	-0.9
GATE DRIVER					
V_{OH}	High-level output voltage	$I_{OUT} = -200\text{ mA}$, $V_{CC} = 15\text{ V}$			
			12.0	12.8	
V_{OL}	Low-level output voltage	$I_{OUT} = 200\text{ mA}$			
				1.0	2.2
		$I_{OUT} = 10\text{ mA}$			
				300	500
	Low-level UVLO voltage	$I_{OUT} = 50\text{ mA}$, $V_{CC} = 0\text{ V}$			
				0.9	1.5
	Output rise time ⁽¹⁾	$C_{LOAD} = 1\text{ nF}$			
				35	
	Output fall time ⁽¹⁾	$C_{LOAD} = 1\text{ nF}$			
				35	
	Output peak current ⁽¹⁾	$C_{LOAD} = 10\text{ nF}$			
				1.0	A

(1) Ensured by design. Not production tested.

$$(K) = \frac{I_{IAC} \times (V_{VAO} - 1.5\text{ V})}{(V_{VRMS})^2 \times I_{MOUT}}$$

(2) Gain constant.

PACKAGE DESCRIPTION

**J, N and DW PACKAGES
 (TOP VIEW)**

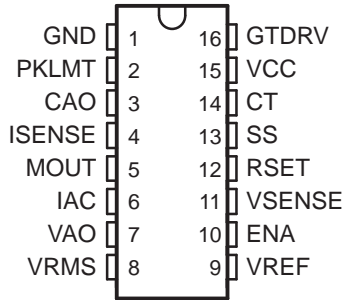

**Q PACKAGE
 (TOP VIEW)**

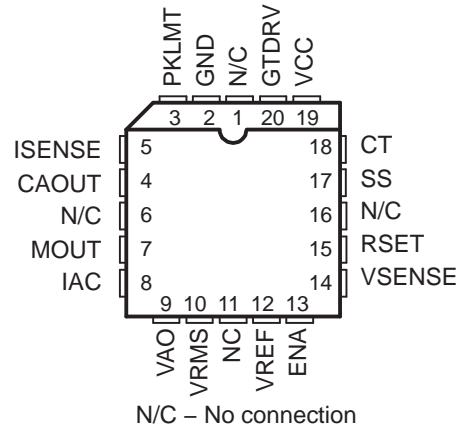

TERMINAL FUNCTIONS

TERMINAL			I/O	DESCRIPTION
NAME	PACKAGES			
	J/N/DW	Q/L		
CAO	3	4	O	Output of the wide bandwidth current amplifier and one of the inputs to the PWM duty-cycle comparator. The output signal generated by this amplifier commands the PWM to force the correct input current. The output can swing from 0.1 V to 7.5 V.
CT	14	18	I	Capacitor from CT to GND sets the PWM oscillator frequency.
ENA	10	13	I	A nominal voltage above 2.65 V on this pin allows the device to begin operating. Once operating, the device shuts off if this pin goes below 2.15 V nominal.
GND	1	2	–	All bypass and timing capacitors connected to GND should have leads as short and direct as possible. All voltages are measured with respect GND.
GTDRV	16	20	O	Output of the PWM is a 1.5-A peak totem-pole MOSFET gate driver on GTDRV. Use a series gate resistor of at least 5 Ω to prevent interaction between the gate impedance and the GTDRV output driver that might cause the GTDRV output to overshoot excessively. Some overshoot of the GTDRV output is always expected when driving a capacitive load.
IAC	6	8	I	Current input to the multiplier, proportional to the instantaneous line voltage. This input to the analog multiplier is a current. The multiplier is tailored for very low distortion from this current input (IAC) to MOUT, so this is the only multiplier input that should be used for sensing instantaneous line voltage.
ISENSE	4	5	I	Switch current sensing input. This is the inverting input to the current amplifier. This input and the non-inverting input MOUT remain functional down to and below GND. Care should be taken to avoid taking these inputs below –0.5 V, because they are protected with diodes to GND.
MOUT	5	7	I/O	Multiplier output and current sense plus. The output of the analog multiplier and the non-inverting input of the current amplifier are connected together at MOUT. The cautions about taking ISENSE below –0.5 V also apply to MOUT. As the multiplier output is a current, this is a high-impedance input similar to I _{SENSE} , so the current amplifier can be configured as a differential amplifier to reject GND noise. $I_{MOUT} \leq 2 \times I_{AC}$
PKLMT	2	3	I	Peak limit. The threshold for PKLMT is 0.0 V. Connect this input to the negative voltage on the current sense resistor. Use a resistor to REF to offset the negative current sense signal up to GND.
RSET	12	15	I	Oscillator charging current and multiplier limit set. A resistor from RSET to ground programs oscillator charging current.
SS	13	17	I	Soft-start. SS remains at GND as long as the device is disabled or V _{CC} is too low. SS pulls up to over 3 V by an internal 14-μA current source when both V _{CC} becomes valid and the device is enabled. SS acts as the reference input to the voltage amplifier if SS is below VREF. With a large capacitor from SS to GND, the reference to the voltage regulating amplifier rises slowly, and increase the PWM duty cycle slowly. In the event of a disable command or a supply dropout, SS will quickly discharge to ground and disable the PWM.
VAO	7	9	I	Voltage amplifier output
VCC	15	19	I	Positive supply rail
VREF	9	12	O	Used to set the peak limit point and as an internal reference for various device functions. This voltage must be present for the device to operate.
VRMS	8	10	I	One of the inputs into the multiplier. This pin provides the input RMS voltage to the multiplier circuitry.
VSENSE	11	14	I	This pin provides the feedback from the output. This input goes into the voltage error amplifier and the output of the error amplifier is another of the inputs into the multiplier circuit.

FUNCTIONAL DESCRIPTION

The UC3854A and UC3854B family of products are designed as pin compatible upgrades to the industry standard UC3854 active power factor correction circuits. The circuit enhancements allow the user to eliminate in most cases several external components currently required to successfully apply the UC3854. In addition, linearity improvements to the multiply, square and divide circuitry optimizes overall system performance. Detailed descriptions of the circuit enhancements are provided below. For in-depth design applications reference data refer to the application notes, *UC3854 Controlled Power Factor Correction Circuit Design (SLUA144)* and *UC3854A and UC3854B Advanced Power Factor Correction Control ICs (SLUA177)*.

Multiply/Square and Divide

The UC3854A/B multiplier design maintains the same gain constant $\left(K = \frac{-1}{V}\right)$ as the UC3854. The relationship between the inputs and output current is given as:

$$I_{MOUT} = I_{IAC} \times \frac{(V_{VAO} - 1.5V)}{K \times (V_{VRMS})^2} \quad (1)$$

This is nearly the same as the UC3854, but circuit differences have improved the performance and application.

The first difference is with the IAC input. The UC3854A/B regulated this pin voltage to the nominal 500 mV over the full operating temperature range, rather than the 6.0 V used on the UC3854. The low offset voltage eliminates the need for a line zero crossing compensating resistor to VREF from IAC that UC3854 designs require. The maximum current at high line into IAC should be limited to 250 μ A for best performance.

Therefore, if $V_{VAC(max)} = 270$ V,

$$R_{IAC} = \frac{270 \times 1.414}{250 \mu A} = 1.53 M\Omega \quad (2)$$

The V_{RMS} pin linear operating range is improved with the UC3854A/B as well. The input range for VRMS extends from 0 V to 5.5 V. Since the UC3854A squaring circuit employs an analog multiplier, rather than a linear approximation, accuracy is improved, and discontinuities are eliminated. The external divider network connected to VRMS should produce 1.5 V at low line (85 VAC). This puts 4.77 V on VRMS at high line (270 VAC) which is well within its operating range.

The voltage amplifier output forms the third input to the multiplier and is internally clamped to 6.0 V. This eliminated an external zener clamp often used in UC3854 designs. The offset voltage at this input to the multiplier has been raised on the UC3854A/B to 1.5 V.

The multiplier output pin, which is also common to the current amplifier non-inverting input, has a -0.3 V to 5.0 V output range, compared to the -0.3 V to 2.5 V range of the UC3854. This improvement allows the UC3854A/B to be used in applications where the current sense signal amplitude is very large.

Voltage Amplifier

The UC3854A/B voltage amplifier design is essentially similar to the UC3854 with two exceptions. The first is with the internal connection. The lower voltage reduces the amount of charge on the compensation capacitors, which provides improved recovery from large signal events, such as line dropouts, or power interruption. It also minimizes the dc current flowing through the feedback. The output of the voltage amplifier is also changed. In addition to a 6.0-V temperature compensated clamp, the output short circuit current has been lowered to 2 mA typical, and an active pull down has replaced the passive pull down of the UC3854.

Current Amplifier

The current amplifier for an average current PFC controller needs a low offset voltage in order to minimize ac line current distortion. With this in mind, the UC3854A/B current amplifier has improved the input offset voltage from ± 4 mV to 0 V to ± 3 mV. The negative offset of the UC3854A/B assures that the PWM circuit will not drive the MOSFET is the current command is zero (both current amplifier inputs zero.) Previous designs required an external offset cancellation network to implement this key feature. The bandwidth of the current amplifier has been improved as well to 5 MHz typical. While this is not generally an issue at 50 Hz or 60 Hz inputs, it is essential for 400 Hz input avionics applications.

Miscellaneous

Several other important enhancements have been implemented in the UC3854A/B. AV_{CC} supply voltage clamp at 20 V allows the controller to be current fed if desired. The lower startup supply current (250 μ A typical), substantially reduces the power requirements of an offline startup resistor. The 10.5 V/10 V UVLO option (UC3854B) enables the controller to be powered off of an auxiliary 12-V supply.

The VREF GOOD comparator assures that the MOSFET driver output remains low if the supply of the 7.5 V reference are not yet up. This improvement eliminates the need for external Schottky diodes on the PKLMT and Mult Out pins that some UC3854 designs require. The propagation delay of the disable feature has been improved to 300 ns typical. This delay was proportional to the size of the VREF capacitor on the UC3854, and is typically several orders of magnitude slower.

TYPICAL CHARACTERISTICS

GATE DRIVE TIMING
 VS
 LOAD CAPACITANCE

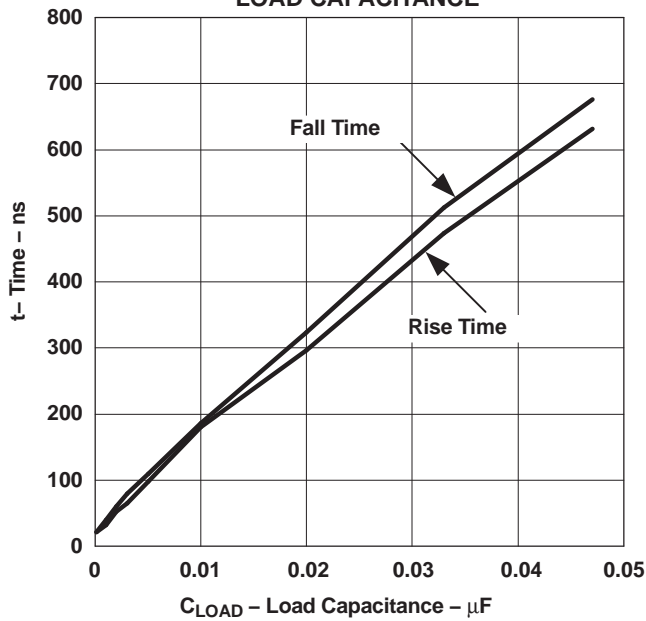

Figure 1.

GATE DRIVE MAXIMUM DUTY CYCLE
 VS
 OSCILLATOR CHARGING RESISTANCE

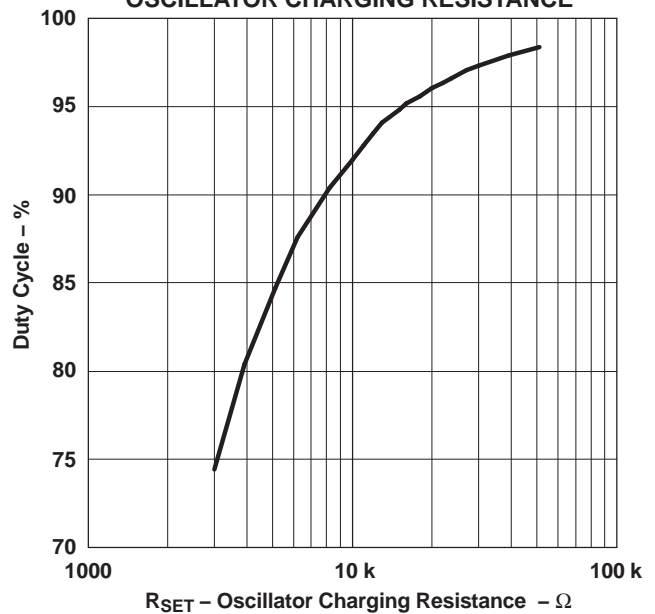

Figure 2.

MULTIPLIER GAIN CONSTANT
 VS
 SUPPLY CURRENT

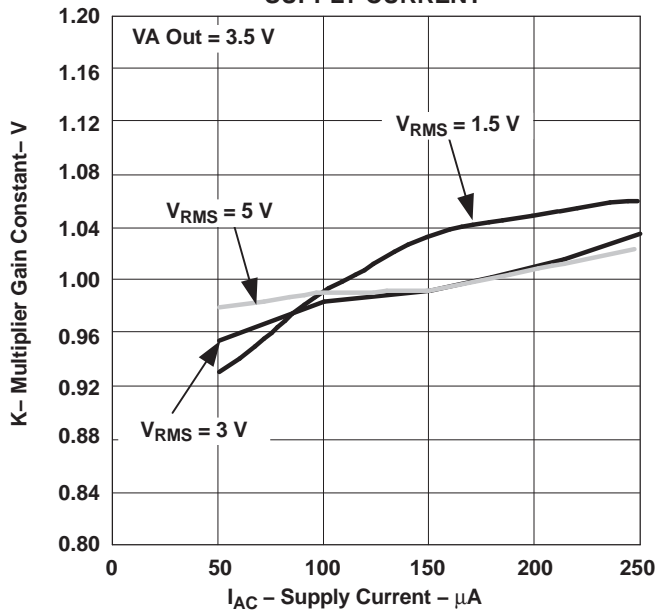

Figure 3.

MULTIPLIER GAIN CONSTANT
 VS
 SUPPLY CURRENT

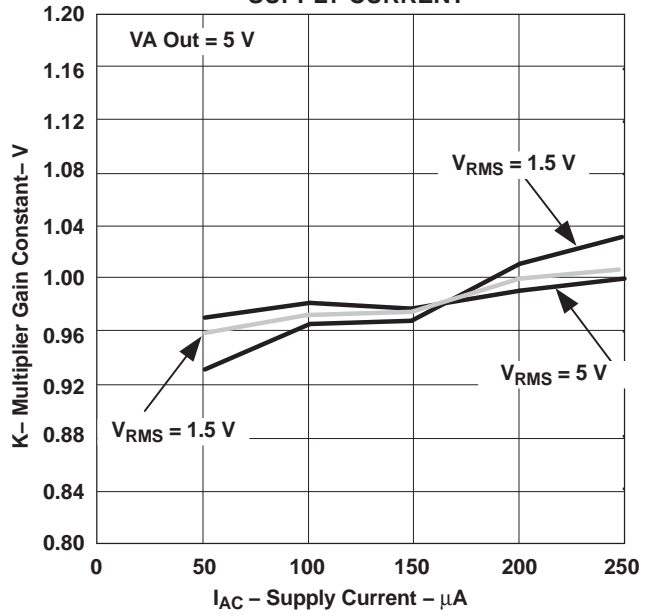
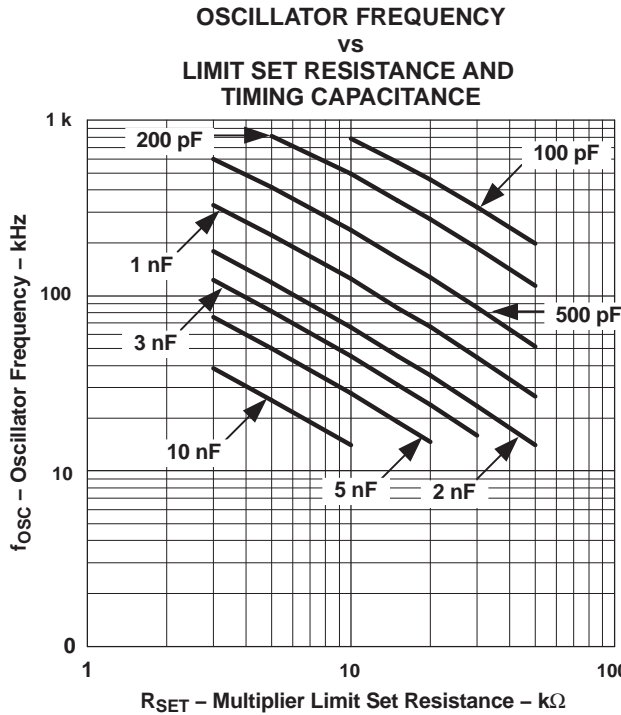
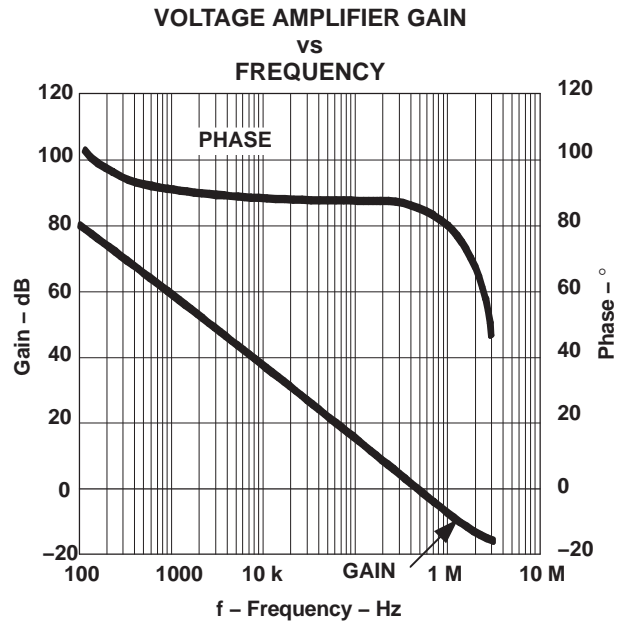
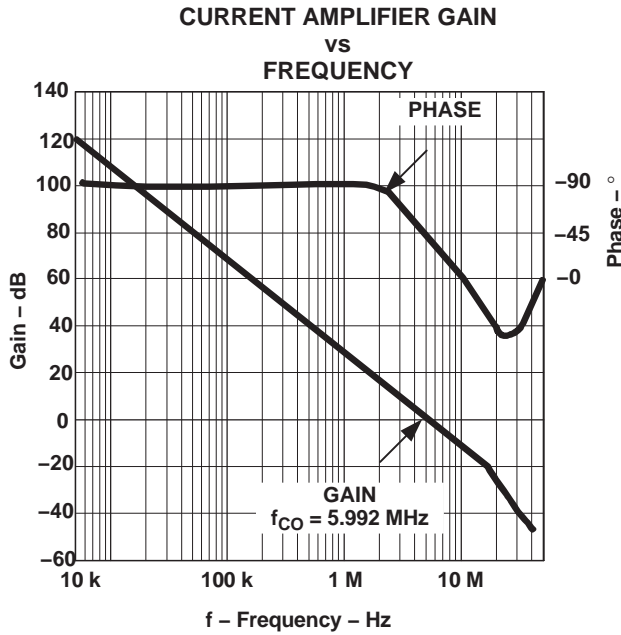

Figure 4.

TYPICAL CHARACTERISTICS (continued)



PACKAGING INFORMATION

Orderable Device	Status (1)	Package Type	Package Drawing	Pins	Package Qty	Eco Plan (2)	Lead/Ball Finish (6)	MSL Peak Temp (3)	Op Temp (°C)	Device Marking (4/5)	Samples
5962-9326102MEA	ACTIVE	CDIP	J	16	1	TBD	A42	N / A for Pkg Type	-55 to 125	5962-9326102MEA A UC1854BJ/883B	Samples
UC1854BJ	ACTIVE	CDIP	J	16	1	TBD	A42	N / A for Pkg Type	-55 to 125	UC1854BJ	Samples
UC1854BJ883B	ACTIVE	CDIP	J	16	1	TBD	A42	N / A for Pkg Type	-55 to 125	5962-9326102MEA A UC1854BJ/883B	Samples
UC2854ADW	ACTIVE	SOIC	DW	16	40	Green (RoHS & no Sb/Br)	CU NIPDAU	Level-2-260C-1 YEAR	-40 to 85	UC2854ADW	Samples
UC2854ADWTR	ACTIVE	SOIC	DW	16	2000	Green (RoHS & no Sb/Br)	CU NIPDAU	Level-2-260C-1 YEAR	-40 to 85	UC2854ADW	Samples
UC2854AN	ACTIVE	PDIP	N	16	25	Green (RoHS & no Sb/Br)	CU NIPDAU	N / A for Pkg Type	-40 to 85	UC2854AN	Samples
UC2854ANG4	ACTIVE	PDIP	N	16	25	Green (RoHS & no Sb/Br)	CU NIPDAU	N / A for Pkg Type	-40 to 85	UC2854AN	Samples
UC2854BDW	ACTIVE	SOIC	DW	16	40	Green (RoHS & no Sb/Br)	CU NIPDAU	Level-2-260C-1 YEAR	-40 to 85	UC2854BDW	Samples
UC2854BDWG4	ACTIVE	SOIC	DW	16	40	Green (RoHS & no Sb/Br)	CU NIPDAU	Level-2-260C-1 YEAR	-40 to 85	UC2854BDW	Samples
UC2854BDWTR	ACTIVE	SOIC	DW	16	2000	Green (RoHS & no Sb/Br)	CU NIPDAU	Level-2-260C-1 YEAR	-40 to 85	UC2854BDW	Samples
UC2854BDWTRG4	ACTIVE	SOIC	DW	16	2000	Green (RoHS & no Sb/Br)	CU NIPDAU	Level-2-260C-1 YEAR	-40 to 85	UC2854BDW	Samples
UC2854BN	ACTIVE	PDIP	N	16	25	Green (RoHS & no Sb/Br)	CU NIPDAU	N / A for Pkg Type	-40 to 85	UC2854BN	Samples
UC2854J	ACTIVE	CDIP	J	16	1	TBD	A42	N / A for Pkg Type	-40 to 85	UC2854J	Samples
UC3854ADW	ACTIVE	SOIC	DW	16	40	Green (RoHS & no Sb/Br)	CU NIPDAU	Level-2-260C-1 YEAR	0 to 70	UC3854ADW	Samples
UC3854ADWG4	ACTIVE	SOIC	DW	16	40	Green (RoHS & no Sb/Br)	CU NIPDAU	Level-2-260C-1 YEAR	0 to 70	UC3854ADW	Samples
UC3854ADWTR	ACTIVE	SOIC	DW	16	2000	Green (RoHS & no Sb/Br)	CU NIPDAU	Level-2-260C-1 YEAR	0 to 70	UC3854ADW	Samples

Orderable Device	Status (1)	Package Type	Package Drawing	Pins	Package Qty	Eco Plan (2)	Lead/Ball Finish (6)	MSL Peak Temp (3)	Op Temp (°C)	Device Marking (4/5)	Samples
UC3854ADWTRG4	ACTIVE	SOIC	DW	16	2000	Green (RoHS & no Sb/Br)	CU NIPDAU	Level-2-260C-1 YEAR	0 to 70	UC3854ADW	Samples
UC3854AN	ACTIVE	PDIP	N	16	25	Green (RoHS & no Sb/Br)	CU NIPDAU	N / A for Pkg Type	0 to 70	UC3854AN	Samples
UC3854ANG4	ACTIVE	PDIP	N	16	25	Green (RoHS & no Sb/Br)	CU NIPDAU	N / A for Pkg Type	0 to 70	UC3854AN	Samples
UC3854BDW	ACTIVE	SOIC	DW	16	40	Green (RoHS & no Sb/Br)	CU NIPDAU	Level-2-260C-1 YEAR	0 to 70	UC3854BDW	Samples
UC3854BDWG4	ACTIVE	SOIC	DW	16	40	Green (RoHS & no Sb/Br)	CU NIPDAU	Level-2-260C-1 YEAR	0 to 70	UC3854BDW	Samples
UC3854BDWTR	ACTIVE	SOIC	DW	16	2000	Green (RoHS & no Sb/Br)	CU NIPDAU	Level-2-260C-1 YEAR	0 to 70	UC3854BDW	Samples
UC3854BDWTRG4	ACTIVE	SOIC	DW	16	2000	Green (RoHS & no Sb/Br)	CU NIPDAU	Level-2-260C-1 YEAR	0 to 70	UC3854BDW	Samples
UC3854BN	ACTIVE	PDIP	N	16	25	Green (RoHS & no Sb/Br)	CU NIPDAU	N / A for Pkg Type	0 to 70	UC3854BN	Samples
UC3854BNG4	ACTIVE	PDIP	N	16	25	Green (RoHS & no Sb/Br)	CU NIPDAU	N / A for Pkg Type	0 to 70	UC3854BN	Samples

(1) The marketing status values are defined as follows:

ACTIVE: Product device recommended for new designs.

LIFEBUY: TI has announced that the device will be discontinued, and a lifetime-buy period is in effect.

NRND: Not recommended for new designs. Device is in production to support existing customers, but TI does not recommend using this part in a new design.

PREVIEW: Device has been announced but is not in production. Samples may or may not be available.

OBSELETE: TI has discontinued the production of the device.

(2) **RoHS:** TI defines "RoHS" to mean semiconductor products that are compliant with the current EU RoHS requirements for all 10 RoHS substances, including the requirement that RoHS substance do not exceed 0.1% by weight in homogeneous materials. Where designed to be soldered at high temperatures, "RoHS" products are suitable for use in specified lead-free processes. TI may reference these types of products as "Pb-Free".

RoHS Exempt: TI defines "RoHS Exempt" to mean products that contain lead but are compliant with EU RoHS pursuant to a specific EU RoHS exemption.

Green: TI defines "Green" to mean the content of Chlorine (Cl) and Bromine (Br) based flame retardants meet JS709B low halogen requirements of <=1000ppm threshold. Antimony trioxide based flame retardants must also meet the <=1000ppm threshold requirement.

(3) MSL, Peak Temp. - The Moisture Sensitivity Level rating according to the JEDEC industry standard classifications, and peak solder temperature.

(4) There may be additional marking, which relates to the logo, the lot trace code information, or the environmental category on the device.

(5) Multiple Device Markings will be inside parentheses. Only one Device Marking contained in parentheses and separated by a "-" will appear on a device. If a line is indented then it is a continuation of the previous line and the two combined represent the entire Device Marking for that device.

(6) Lead/Ball Finish - Orderable Devices may have multiple material finish options. Finish options are separated by a vertical ruled line. Lead/Ball Finish values may wrap to two lines if the finish value exceeds the maximum column width.

Important Information and Disclaimer:The information provided on this page represents TI's knowledge and belief as of the date that it is provided. TI bases its knowledge and belief on information provided by third parties, and makes no representation or warranty as to the accuracy of such information. Efforts are underway to better integrate information from third parties. TI has taken and continues to take reasonable steps to provide representative and accurate information but may not have conducted destructive testing or chemical analysis on incoming materials and chemicals. TI and TI suppliers consider certain information to be proprietary, and thus CAS numbers and other limited information may not be available for release.

In no event shall TI's liability arising out of such information exceed the total purchase price of the TI part(s) at issue in this document sold by TI to Customer on an annual basis.

OTHER QUALIFIED VERSIONS OF UC1854B, UC2854B, UC2854M, UC3854B :

- Catalog: [UC3854B](#), [UC2854](#)
- Enhanced Product: [UC2854B-EP](#)
- Military: [UC2854BM](#), [UC1854B](#)

NOTE: Qualified Version Definitions:

- Catalog - TI's standard catalog product
- Enhanced Product - Supports Defense, Aerospace and Medical Applications
- Military - QML certified for Military and Defense Applications

TAPE AND REEL INFORMATION

QUADRANT ASSIGNMENTS FOR PIN 1 ORIENTATION IN TAPE

*All dimensions are nominal

Device	Package Type	Package Drawing	Pins	SPQ	Reel Diameter (mm)	Reel Width W1 (mm)	A0 (mm)	B0 (mm)	K0 (mm)	P1 (mm)	W (mm)	Pin1 Quadrant
UC2854ADWTR	SOIC	DW	16	2000	330.0	16.4	10.75	10.7	2.7	12.0	16.0	Q1
UC3854ADWTR	SOIC	DW	16	2000	330.0	16.4	10.75	10.7	2.7	12.0	16.0	Q1

TAPE AND REEL BOX DIMENSIONS

*All dimensions are nominal

Device	Package Type	Package Drawing	Pins	SPQ	Length (mm)	Width (mm)	Height (mm)
UC2854ADWTR	SOIC	DW	16	2000	367.0	367.0	38.0
UC3854ADWTR	SOIC	DW	16	2000	367.0	367.0	38.0

FK (S-CQCC-N**)

LEADLESS CERAMIC CHIP CARRIER

28 TERMINAL SHOWN



NO. OF TERMINALS **	A		B	
	MIN	MAX	MIN	MAX
20	0.342 (8,69)	0.358 (9,09)	0.307 (7,80)	0.358 (9,09)
28	0.442 (11,23)	0.458 (11,63)	0.406 (10,31)	0.458 (11,63)
44	0.640 (16,26)	0.660 (16,76)	0.495 (12,58)	0.560 (14,22)
52	0.740 (18,78)	0.761 (19,32)	0.495 (12,58)	0.560 (14,22)
68	0.938 (23,83)	0.962 (24,43)	0.850 (21,6)	0.858 (21,8)
84	1.141 (28,99)	1.165 (29,59)	1.047 (26,6)	1.063 (27,0)



4040140/D 01/11

- NOTES:
- All linear dimensions are in inches (millimeters).
 - This drawing is subject to change without notice.
 - This package can be hermetically sealed with a metal lid.
 - Falls within JEDEC MS-004

FN 20

GENERIC PACKAGE VIEW

PLCC - 4.57 mm max height

PLASTIC CHIP CARRIER

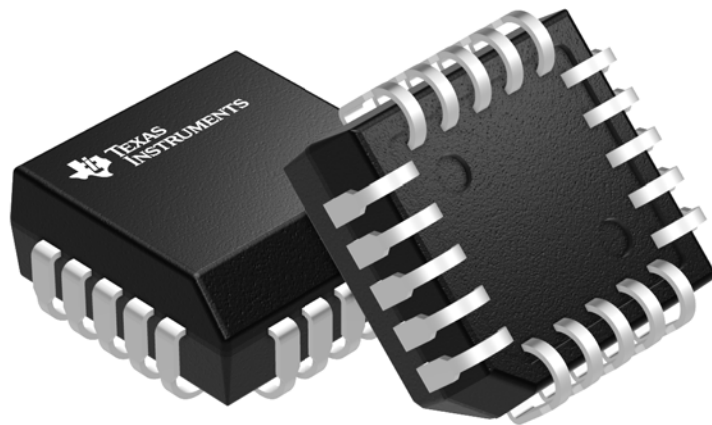

Images above are just a representation of the package family, actual package may vary.
Refer to the product data sheet for package details.

4040005-2/C



PACKAGE OUTLINE

FN0020A

PLCC - 4.57 mm max height

PLASTIC CHIP CARRIER

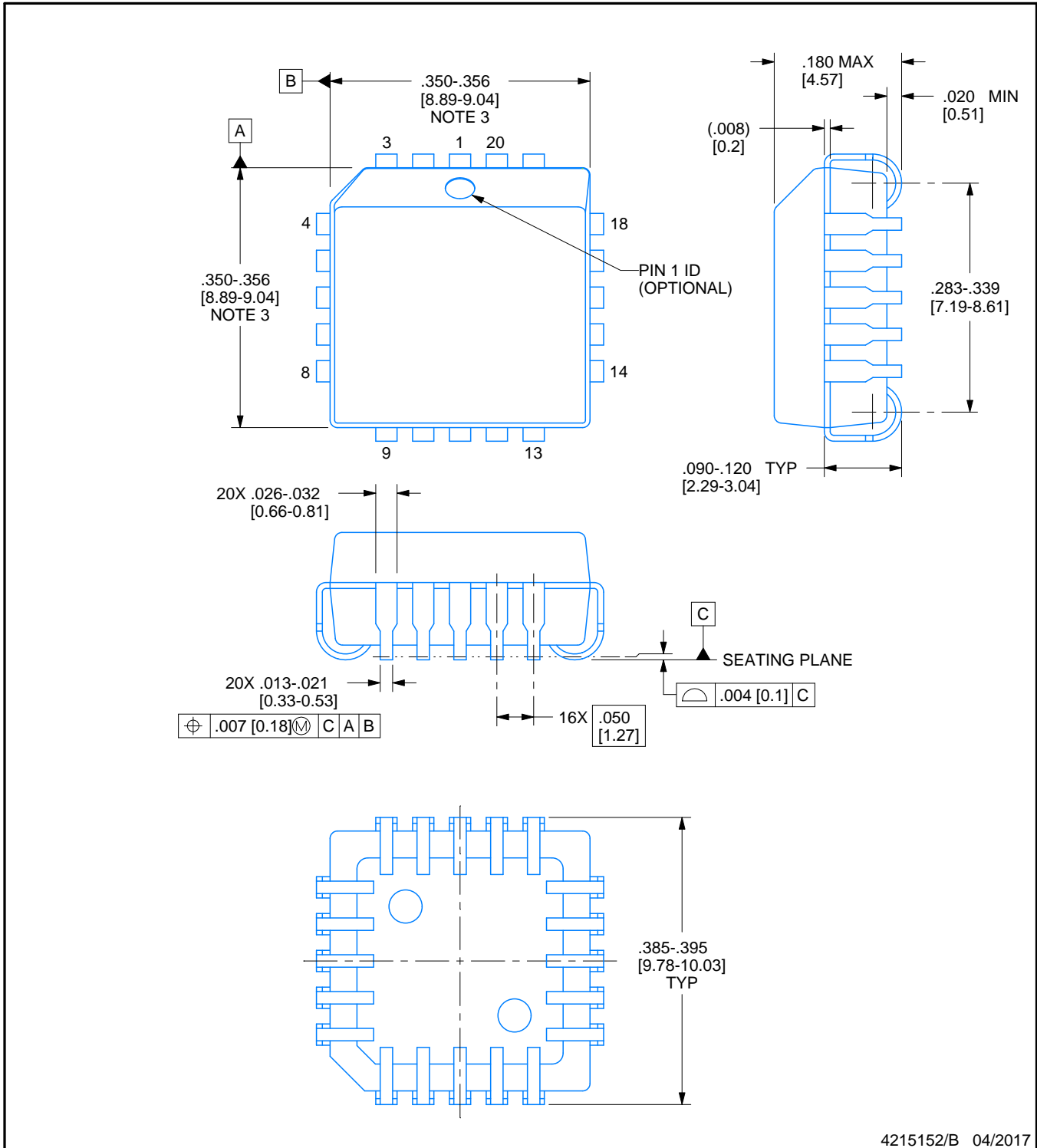

4215152/B 04/2017

NOTES:

1. All linear dimensions are in inches. Any dimensions in brackets are in millimeters. Any dimensions in parenthesis are for reference only. Controlling dimensions are in inches. Dimensioning and tolerancing per ASME Y14.5M.
2. This drawing is subject to change without notice.
3. Dimension does not include mold protrusion. Maximum allowable mold protrusion .01 in [0.25 mm] per side.
4. Reference JEDEC registration MS-018.

EXAMPLE BOARD LAYOUT

FN0020A

PLCC - 4.57 mm max height

PLASTIC CHIP CARRIER

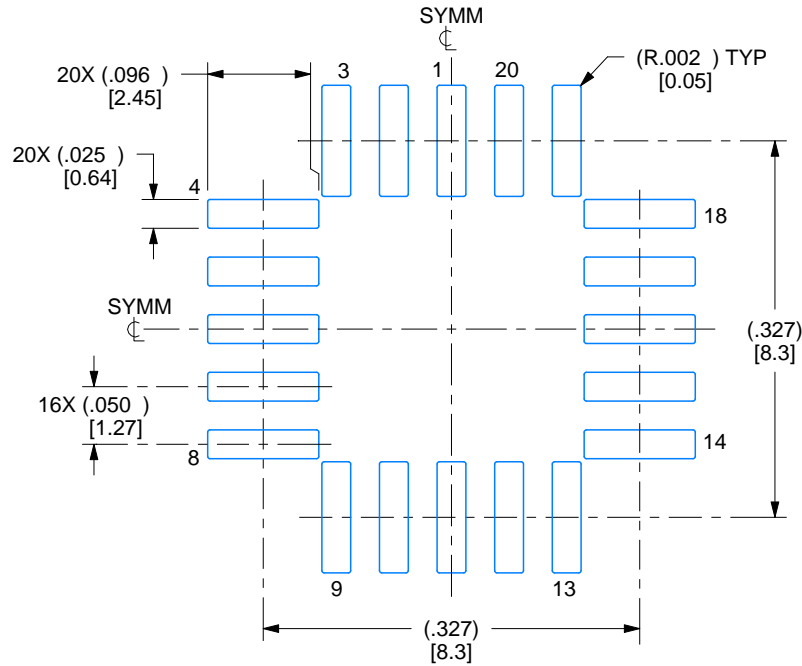

LAND PATTERN EXAMPLE
EXPOSED METAL SHOWN
SCALE:6X

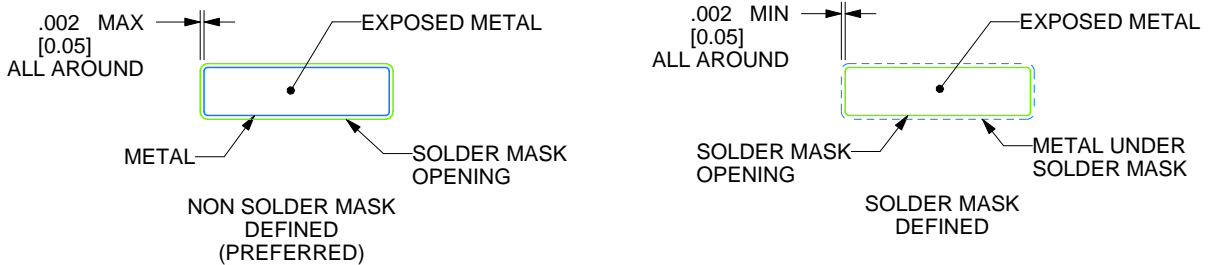

SOLDER MASK DETAILS

4215152/B 04/2017

NOTES: (continued)

- Publication IPC-7351 may have alternate designs.
- Solder mask tolerances between and around signal pads can vary based on board fabrication site.

EXAMPLE STENCIL DESIGN

FN0020A

PLCC - 4.57 mm max height

PLASTIC CHIP CARRIER

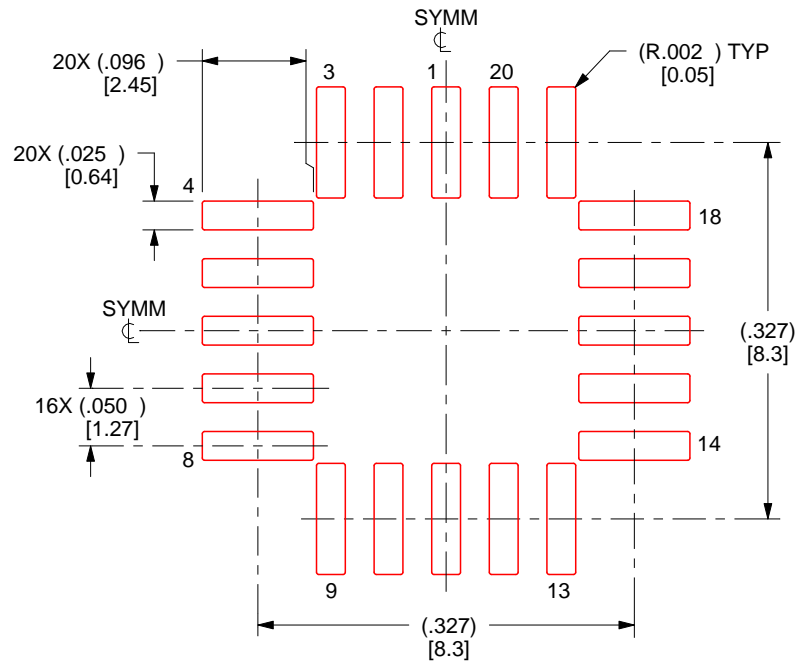

SOLDER PASTE EXAMPLE
BASED ON 0.125 mm THICK STENCIL
SCALE:6X

4215152/B 04/2017

NOTES: (continued)

7. Laser cutting apertures with trapezoidal walls and rounded corners may offer better paste release. IPC-7525 may have alternate design recommendations.
8. Board assembly site may have different recommendations for stencil design.

GENERIC PACKAGE VIEW

DW 16

SOIC - 2.65 mm max height

7.5 x 10.3, 1.27 mm pitch

SMALL OUTLINE INTEGRATED CIRCUIT

This image is a representation of the package family, actual package may vary.
Refer to the product data sheet for package details.



4224780/A

EXAMPLE STENCIL DESIGN

DW0016A

SOIC - 2.65 mm max height

SOIC



SOLDER PASTE EXAMPLE
BASED ON 0.125 mm THICK STENCIL
SCALE:7X

4220721/A 07/2016

NOTES: (continued)

8. Laser cutting apertures with trapezoidal walls and rounded corners may offer better paste release. IPC-7525 may have alternate design recommendations.
9. Board assembly site may have different recommendations for stencil design.

J (R-GDIP-T**)

14 LEADS SHOWN

CERAMIC DUAL IN-LINE PACKAGE



DIM \ PINS **	14	16	18	20
A	0.300 (7,62) BSC	0.300 (7,62) BSC	0.300 (7,62) BSC	0.300 (7,62) BSC
B MAX	0.785 (19,94)	.840 (21,34)	0.960 (24,38)	1.060 (26,92)
B MIN	—	—	—	—
C MAX	0.300 (7,62)	0.300 (7,62)	0.310 (7,87)	0.300 (7,62)
C MIN	0.245 (6,22)	0.245 (6,22)	0.220 (5,59)	0.245 (6,22)



4040083/F 03/03

- NOTES:
- All linear dimensions are in inches (millimeters).
 - This drawing is subject to change without notice.
 - This package is hermetically sealed with a ceramic lid using glass frit.
 - Index point is provided on cap for terminal identification only on press ceramic glass frit seal only.
 - Falls within MIL STD 1835 GDIP1-T14, GDIP1-T16, GDIP1-T18 and GDIP1-T20.

IMPORTANT NOTICE AND DISCLAIMER

TI PROVIDES TECHNICAL AND RELIABILITY DATA (INCLUDING DATASHEETS), DESIGN RESOURCES (INCLUDING REFERENCE DESIGNS), APPLICATION OR OTHER DESIGN ADVICE, WEB TOOLS, SAFETY INFORMATION, AND OTHER RESOURCES "AS IS" AND WITH ALL FAULTS, AND DISCLAIMS ALL WARRANTIES, EXPRESS AND IMPLIED, INCLUDING WITHOUT LIMITATION ANY IMPLIED WARRANTIES OF MERCHANTABILITY, FITNESS FOR A PARTICULAR PURPOSE OR NON-INFRINGEMENT OF THIRD PARTY INTELLECTUAL PROPERTY RIGHTS.

These resources are intended for skilled developers designing with TI products. You are solely responsible for (1) selecting the appropriate TI products for your application, (2) designing, validating and testing your application, and (3) ensuring your application meets applicable standards, and any other safety, security, or other requirements. These resources are subject to change without notice. TI grants you permission to use these resources only for development of an application that uses the TI products described in the resource. Other reproduction and display of these resources is prohibited. No license is granted to any other TI intellectual property right or to any third party intellectual property right. TI disclaims responsibility for, and you will fully indemnify TI and its representatives against, any claims, damages, costs, losses, and liabilities arising out of your use of these resources.

TI's products are provided subject to TI's Terms of Sale (www.ti.com/legal/termsofsale.html) or other applicable terms available either on ti.com or provided in conjunction with such TI products. TI's provision of these resources does not expand or otherwise alter TI's applicable warranties or warranty disclaimers for TI products.

Mailing Address: Texas Instruments, Post Office Box 655303, Dallas, Texas 75265
Copyright © 2019, Texas Instruments Incorporated

Looking for pricing, stock, or lifecycle information?

Click below to explore more details on WIN SOURCE:

 [View UC3854ADW](#) on WIN SOURCE

 [Texas Instruments](#) Information

Optimize Your Supply Chain with WIN SOURCE Solutions

-  Global Sourcing Solution
-  Obsolete Management
-  Cost Control Management
-  Shortage Management
-  Alternative Solution
-  Excess Inventory Management