



# THE DATASHEET OF UC3844AD1





# UC284XA UC384XA

## HIGH PERFORMANCE CURRENT MODE PWM CONTROLLER

NOT FOR NEW DESIGN

### 1 FEATURES

- TRIMMED OSCILLATOR DISCHARGE CURRENT
- CURRENT MODE OPERATION TO 500kHz  
AUTOMATIC FEED FORWARD  
COMPENSATION
- LATCHING PWM FOR CYCLE-BY-CYCLE  
CURRENT LIMITING
- INTERNALLY TRIMMED REFERENCE WITH  
UNDERVOLTAGE LOCKOUT
- HIGH CURRENT TOTEM POLE OUTPUT  
UNDERVOLTAGE LOCKOUT WITH  
HYSTERESIS
- LOW START-UP CURRENT ( $< 0.5\text{mA}$ )  
DOUBLE PULSE SUPPRESSION

### 2 DESCRIPTION

The UC384xA family of control ICs provides the necessary features to implement off-line or DC to DC fixed frequency current mode control schemes with a minimal external parts count. Internally implemented circuits include a trimmed oscillator for precise DUTY CYCLE CONTROL under voltage lockout featuring start-up current less than 0.5mA, a precision reference trimmed for accuracy at the error amp input, logic to insure latched operation, a PWM comparator which also provides current limit control, and a totem pole output stage designed to source or sink high peak current. The output stage, suitable for driving N-Channel MOS-FETs, is low in the off-state.

Figure 1. Package

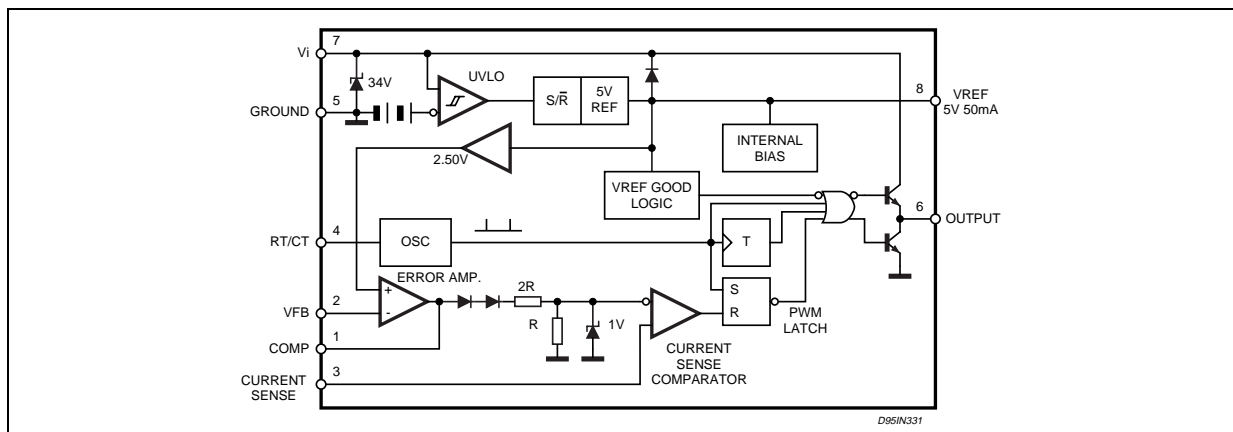

Table 1. Order Codes

Part Number	Package
UC2842AD1; UC3842AD1; UC2843AD1; UC3843AD1; UC2844AD1; UC3844AD1; UC2845AD1; UC3845AD1	SO-8
UC2842AN; UC3842AN; UC2843AN; UC3843AN; UC2844AN; UC3844AN; UC2845AN; UC3845AN	DIP-8

Differences between members of this family are the under-voltage lockout thresholds and maximum duty cycle ranges. The UC3842A and UC3844A have UVLO thresholds of 16V (on) and 10V (off), ideally suited off-line applications. The corresponding thresholds for the UC3843A and UC3845A are 8.5 V and 7.9V. The UC3842A and UC3843A can operate to duty cycles approaching 100%. A range of the zero to  $< 50\%$  is obtained by the UC3844A and UC3845A by the addition of an internal toggle flip flop which blanks the output off every other clock cycle.

Figure 2. Block Diagram (toggle flip flop used only in UC3844A and UC3845A)



## UC384XA - UC284XA

**Table 2. Absolute Maximum Ratings**

Symbol	Parameter	Value	Unit
$V_i$	Supply Voltage (low impedance source)	30	V
$V_i$	Supply Voltage ( $I_i < 30\text{mA}$ )	Self Limiting	
$I_O$	Output Current	$\pm 1$	A
$E_O$	Output Energy (capacitive load)	5	$\mu\text{J}$
	Analog Inputs (pins 2, 3)	- 0.3 to 5.5	V
	Error Amplifier Output Sink Current	10	mA
$P_{tot}$	Power Dissipation at $T_{amb} \leq 25^\circ\text{C}$ (DIP-8)	1.25	W
$P_{tot}$	Power Dissipation at $T_{amb} \leq 25^\circ\text{C}$ (SO-8)	800	mW
$T_{stg}$	Storage Temperature Range	- 65 to 150	$^\circ\text{C}$
$T_J$	Junction Operating Temperature	- 40 to 150	$^\circ\text{C}$
$T_L$	Lead Temperature (soldering 10s)	300	$^\circ\text{C}$

\* All voltages are with respect to pin 5, all currents are positive into the specified terminal.

**Figure 3. DIP-8/SO-8 Pin Connection (Top view)**

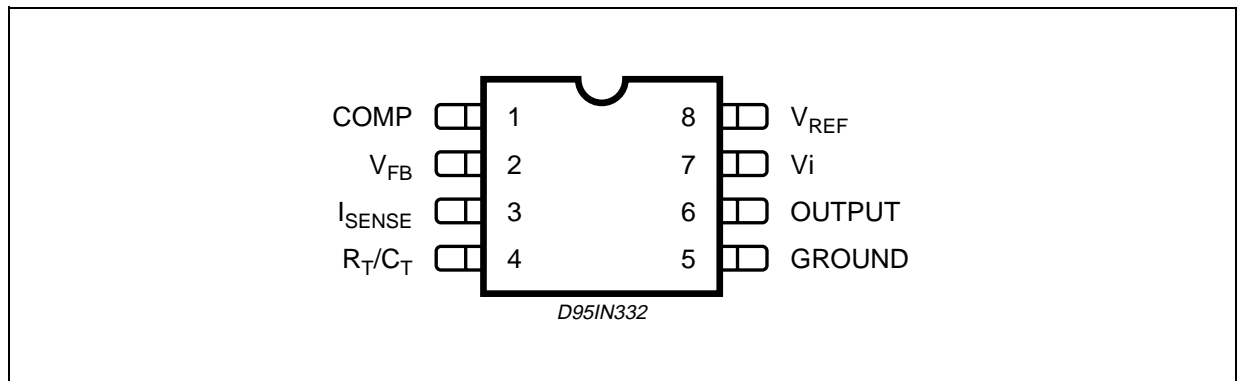

**Table 3. Pin Description**

N°	Pin	Function
1	COMP	This pin is the Error Amplifier output and is made available for loop compensation.
2	$V_{FB}$	This is the inverting input of the Error Amplifier. It is normally connected to the switching power supply output through a resistor divider.
3	$I_{SENSE}$	A voltage proportional to inductor current is connected to this input. The PWM uses this information to terminate the output switch conduction.
4	$R_T/C_T$	The oscillator frequency and maximum Output duty cycle are programmed by connecting resistor $R_T$ to $V_{ref}$ and capacitor $C_T$ to ground. Operation to 500kHz is possible.
5	GROUND	This pin is the combined control circuitry and power ground.
6	OUTPUT	This output directly drives the gate of a power MOSFET. Peak currents up to 1A are sourced and sunk by this pin.
7	$V_{CC}$	This pin is the positive supply of the control IC.
8	$V_{ref}$	This is the reference output. It provides charging current for capacitor $C_T$ through resistor $R_T$ .

Table 4. Thermal Data

Symbol	Parameter	DIP-8	SO-8	Unit
$R_{th\ j-amb}$	Thermal Resistance Junction-ambient	Max. 100	150	°C/W

Table 5. Electrical Characteristics

( [note 1] Unless otherwise stated, these specifications apply for  $-25 < T_{amb} < 85^{\circ}\text{C}$  for UC284XA;  $0 < T_{amb} < 70^{\circ}\text{C}$  for UC384XA;  $V_i = 15\text{V}$  (note 5);  $R_T = 10\text{K}$ ;  $C_T = 3.3\text{nF}$ )

Symbol	Parameter	Test Condition	UC284XA			UC384XA			Unit
			Min.	Typ.	Max.	Min.	Typ.	Max.	
<b>REFERENCE SECTION</b>									
$V_{REF}$	Output Voltage	$T_j = 25^{\circ}\text{C}$ $I_o = 1\text{mA}$	4.95	5.00	5.05	4.90	5.00	5.10	V
$\Delta V_{REF}$	Line Regulation	$12\text{V} \leq V_i \leq 25\text{V}$		2	20		2	20	mV
$\Delta V_{REF}$	Load Regulation	$1 \leq I_o \leq 20\text{mA}$		3	25		3	25	mV
$\Delta V_{REF}/\Delta T$	Temperature Stability	(Note 2)		0.2			0.2		mV/°C
	Total Output Variation	Line, Load, Temperature	4.9		5.1	4.82		5.18	V
$e_N$	Output Noise Voltage	$10\text{Hz} \leq f \leq 10\text{KHz}$ $T_j = 25^{\circ}\text{C}$ (note 2)		50			50		$\mu\text{V}$
	Long Term Stability	$T_{amb} = 125^{\circ}\text{C}$ , 1000Hrs (note 2)		5	25		5	25	mV
ISC	Output Short Circuit		-30	-100	-180	-30	-100	-180	mA
<b>OSCILLATOR SECTION</b>									
$f_{OSC}$	Frequency	$T_j = 25^{\circ}\text{C}$	47	52	57	47	52	57	KHz
$\Delta f_{OSC}/\Delta V$	Frequency Change with Volt.	$V_{CC} = 12\text{V}$ to $25\text{V}$	-	0.2	1	-	0.2	1	%
$\Delta V_{REF}/\Delta T$	Frequency Change with Temp.	$T_A = T_{low}$ to $T_{high}$	-	5	-	-	5	-	%
$V_{OSC}$	Oscillator Voltage Swing	(peak to peak)	-	1.6	-	-	1.6	-	V
$I_{dischg}$	Discharge Current ( $V_{OSC} = 2\text{V}$ )	$T_j = 25^{\circ}\text{C}$	7.8	8.3	8.8	7.8	8.3	8.8	mA
<b>ERROR AMP SECTION</b>									
$V_2$	Input Voltage	$V_{PIN1} = 2.5\text{V}$	2.45	2.50	2.55	2.42	2.50	2.58	V
$I_b$	Input Bias Current	$V_{FB} = 5\text{V}$		-0.1	-1		-0.1	-2	$\mu\text{A}$
	$A_{VOL}$	$2\text{V} \leq V_o \leq 4\text{V}$	65	90		65	90		dB
BW	Unity Gain Bandwidth	$T_j = 25^{\circ}\text{C}$	0.7	1		0.7	1		MHz
PSRR	Power Supply Rejec. Ratio	$12\text{V} \leq V_i \leq 25\text{V}$	60	70		60	70		dB
$I_o$	Output Sink Current	$V_{PIN2} = 2.7\text{V}$ $V_{PIN1} = 1.1\text{V}$	2	12		2	12		mA
$I_o$	Output Source Current	$V_{PIN2} = 2.3\text{V}$ $V_{PIN1} = 5\text{V}$	-0.5	-1		-0.5	-1		mA
	$V_{OUT}$ High	$V_{PIN2} = 2.3\text{V}$ ; $R_L = 15\text{K}\Omega$ to Ground	5	6.2		5	6.2		V
	$V_{OUT}$ Low	$V_{PIN2} = 2.7\text{V}$ ; $R_L = 15\text{K}\Omega$ to Pin 8		0.8	1.1		0.8	1.1	V
<b>CURRENT SENSE SECTION</b>									
$G_V$	Gain	(note 3 & 4)	2.85	3	3.15	2.85	3	3.15	V/V
$V_3$	Maximum Input Signal	$V_{PIN1} = 5\text{V}$ (note 3)	0.9	1	1.1	0.9	1	1.1	V
SVR	Supply Voltage Rejection	$12 \leq V_i \leq 25\text{V}$ (note 3)		70			70		dB
$I_b$	Input Bias Current			-2	-10		-2	-10	$\mu\text{A}$
	Delay to Output			150	300		150	300	ns

## UC384XA - UC284XA

**Table 5. Electrical Characteristics** (continued)

( [note 1] Unless otherwise stated, these specifications apply for  $-25 < T_{amb} < 85^{\circ}\text{C}$  for UC284XA;  $0 < T_{amb} < 70^{\circ}\text{C}$  for UC384XA;  $V_i = 15\text{V}$  (note 5);  $R_T = 10\text{K}$ ;  $C_T = 3.3\text{nF}$ )

Symbol	Parameter	Test Condition	UC284XA			UC384XA			Unit
			Min.	Typ.	Max.	Min.	Typ.	Max.	
<b>OUTPUT SECTION</b>									
V <sub>OL</sub>	Output Low Level	I <sub>SINK</sub> = 20mA		0.1	0.4		0.1	0.4	V
		I <sub>SINK</sub> = 200mA		1.6	2.2		1.6	2.2	V
V <sub>OH</sub>	Output High Level	I <sub>SOURCE</sub> = 20mA	13	13.5		13	13.5		V
		I <sub>SOURCE</sub> = 200mA	12	13.5		12	13.5		V
V <sub>OLS</sub>	UVLO Saturation	V <sub>CC</sub> = 6V; I <sub>SINK</sub> = 1mA		0.7	1.2		0.7	1.2	V
t <sub>r</sub>	Rise Time	T <sub>j</sub> = 25°C C <sub>L</sub> = 1nF <sup>(2)</sup>		50	150		50	150	ns
t <sub>f</sub>	Fall Time	T <sub>j</sub> = 25°C C <sub>L</sub> = 1nF <sup>(2)</sup>		50	150		50	150	ns
<b>UNDER-VOLTAGE LOCKOUT SECTION</b>									
	Start Threshold	X842A/4A	15	16	17	14.5	16	17.5	V
		X843A/5A	7.8	8.4	9.0	7.8	8.4	9.0	V
	Min Operating Voltage After Turn-on	X842A/4A	9	10	11	8.5	10	11.5	V
<b>PWM SECTION</b>									
	Maximum Duty Cycle	X842A/3A	94	96	100	94	96	100	%
		X844A/5A	47	48	50	47	48	50	%
	Minimum Duty Cycle				0		0	%	
<b>TOTAL STANDBY CURRENT</b>									
I <sub>st</sub>	Start-up Current	V <sub>i</sub> = 6.5V for UCX843A/45A		0.3	0.5		0.3	0.5	mA
		V <sub>i</sub> = 14V for UCX842A/44A		0.3	0.5		0.3	0.5	mA
I <sub>i</sub>	Operating Supply Current	V <sub>PIN2</sub> = V <sub>PIN3</sub> = 0V		12	17		12	17	mA
V <sub>iz</sub>	Zener Voltage	I <sub>i</sub> = 25mA	30	36		30	36	V	

- Notes: 1. Max package power dissipation limits must be respected; low duty cycle pulse techniques are used during test maintain T<sub>j</sub> as close to T<sub>amb</sub> as possible.  
2. These parameters, although guaranteed, are not 100% tested in production.  
3. Parameter measured at trip point of latch with V<sub>PIN2</sub> = 0.  
4. Gain defined as :  $A = \Delta V_{PIN1} / \Delta V_{PIN3}$ ;  $0 \leq V_{PIN3} \leq 0.8\text{V}$   
5. Adjust V<sub>i</sub> above the start threshold before setting at 15 V.

Figure 4. Open Loop Test Circuit.

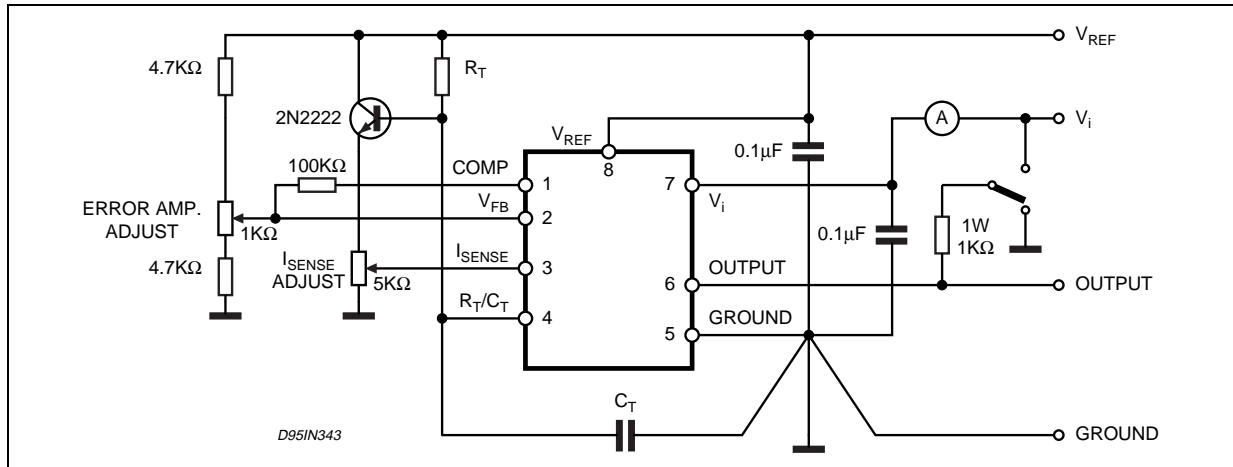

High peak currents associated with capacitive loads necessitate careful grounding techniques. Timing and bypass capacitors should be connected close to pin 5 in a single point ground. The transistor and 5 KΩ potentiometer are used to sample the oscillator waveform and apply an adjustable ramp to pin 3.

Figure 5. Oscillator Frequency vs Timing Resistance

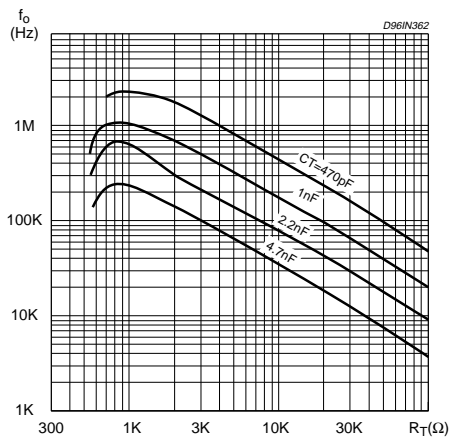

Figure 6. Maximum Duty Cycle vs Timing Resistor

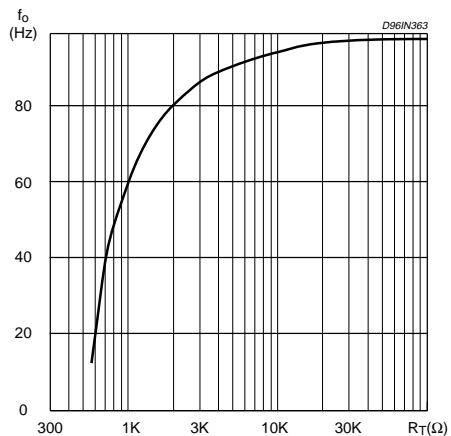

Figure 7. Oscillator Discharge Current vs. Temperature.

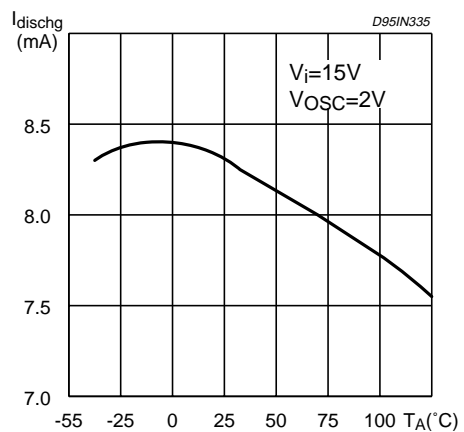

Figure 8. Error Amp Open-Loop Gain and Phase vs. Frequency.

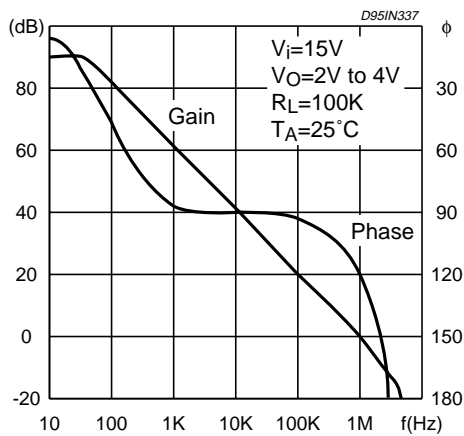

Figure 9. Current Sense Input Threshold vs. Error Amp Output Voltage.

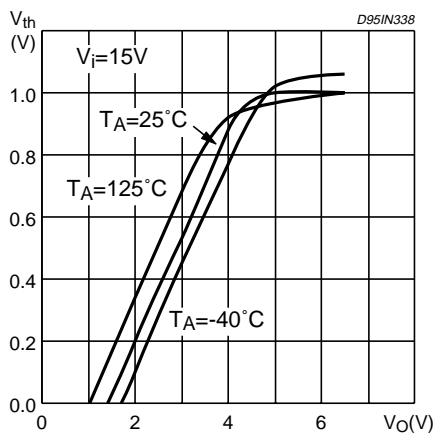

Figure 10. Reference Voltage Change vs. Source Current..

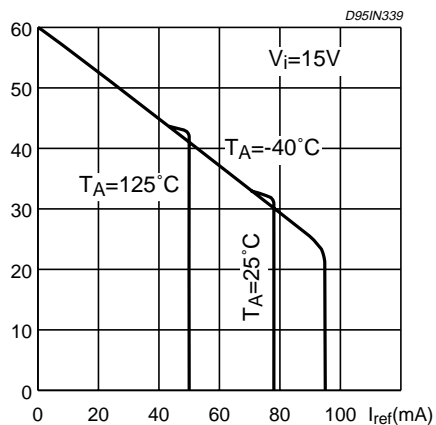

Figure 11. Reference Short Circuit Current vs. Temperature..

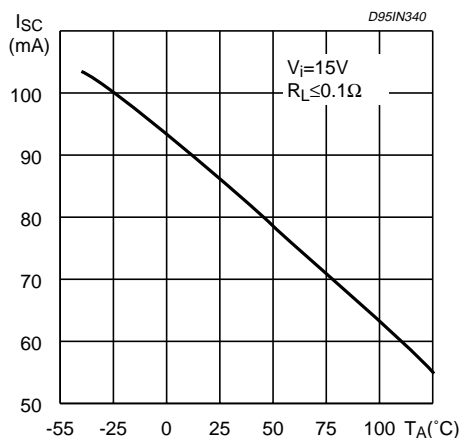

Figure 12. Output Saturation Voltage vs. Load Current.

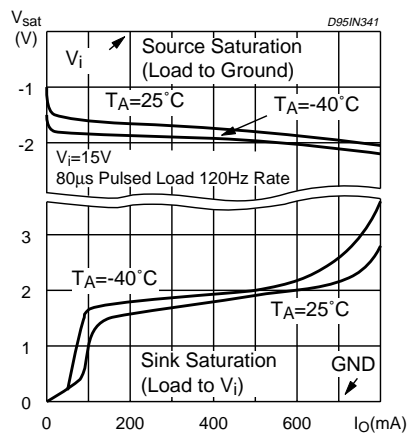

Figure 13. Supply Current vs. Supply Voltage.

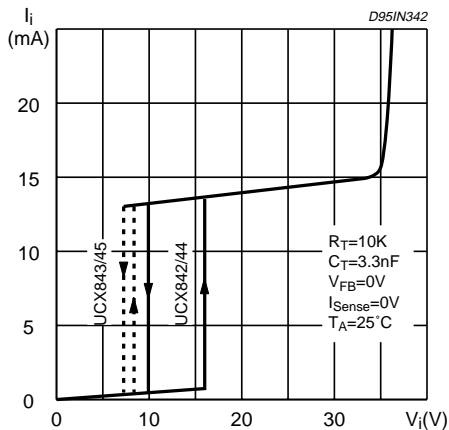

Figure 14. Output Waveform.

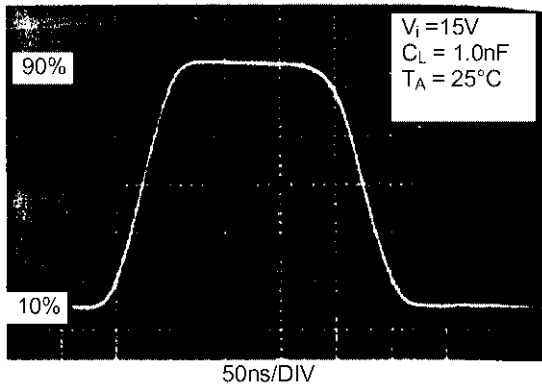

Figure 15. Output Cross Conduction

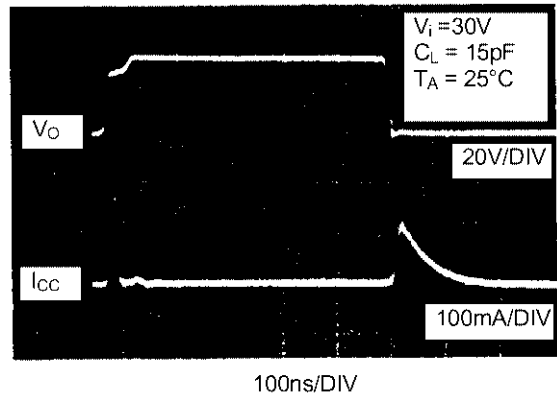

Figure 16. Oscillator and Output Waveforms.

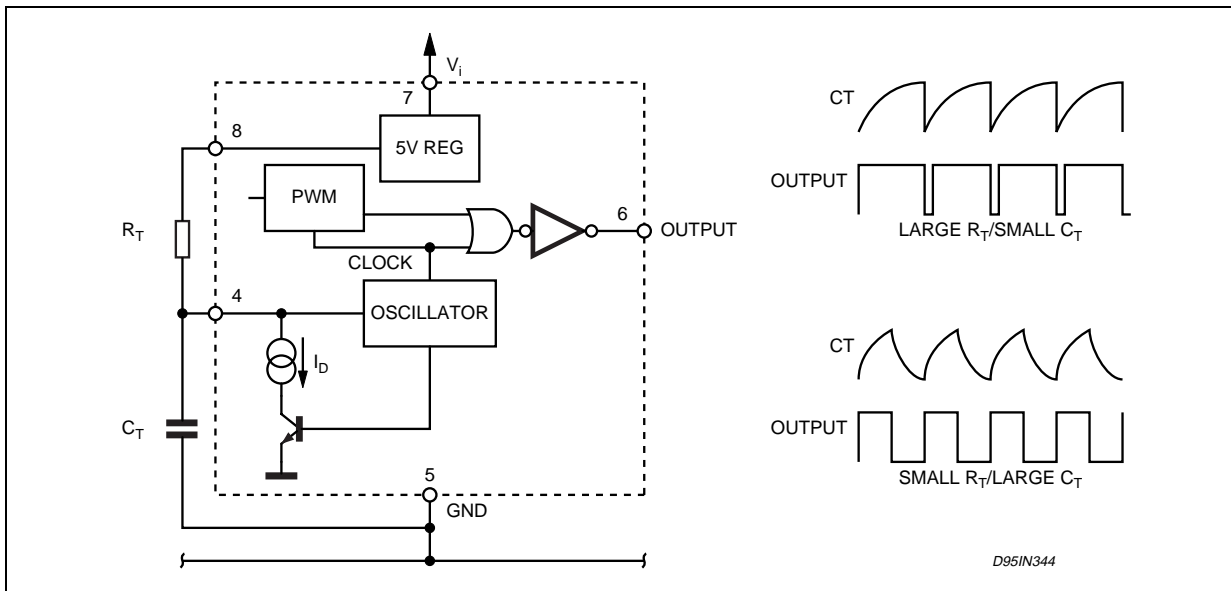

Figure 17. Error Amp Configuration.

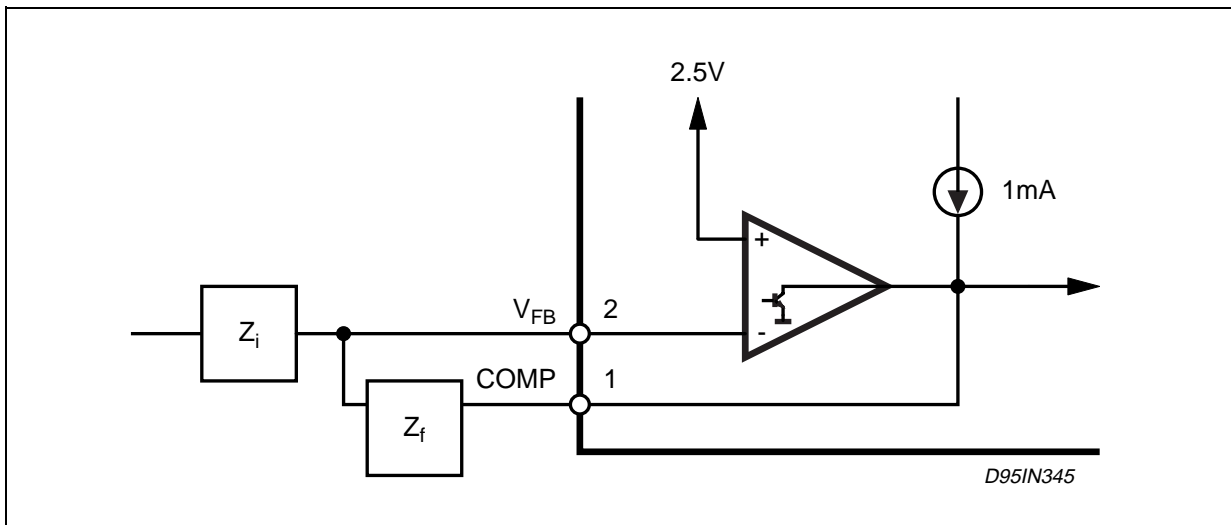

Figure 18. Under Voltage Lockout.

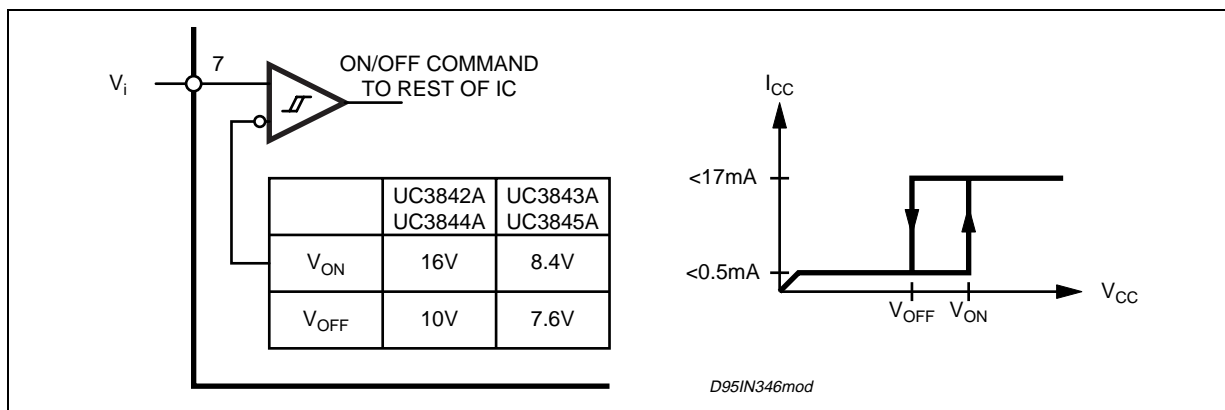
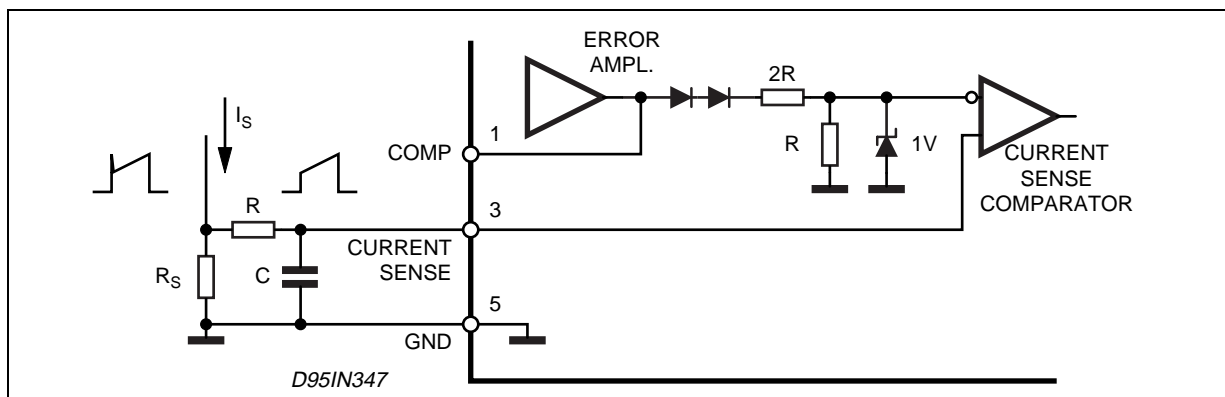

Figure 19. Current Sense Circuit.



Peak current ( $i_s$ ) is determined by the formula

$$I_{Smax} \approx \frac{1.0V}{R_S}$$

A small RC filter may be required to suppress switch transients.

Figure 20. Slope Compensation Techniques.

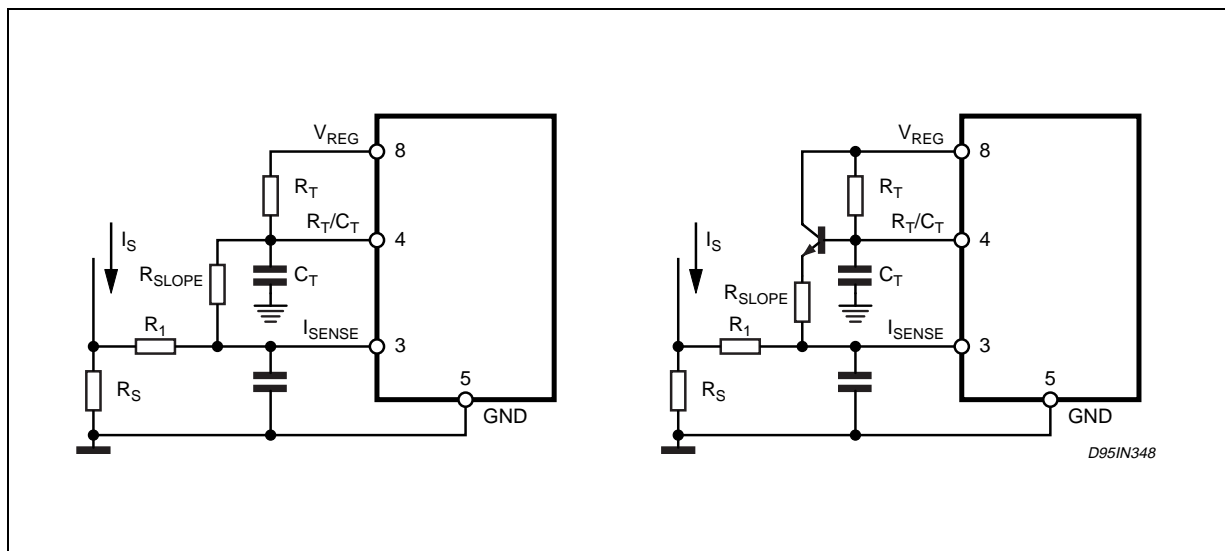

Figure 21. Isolated MOSFET Drive and Current Transformer Sensing.

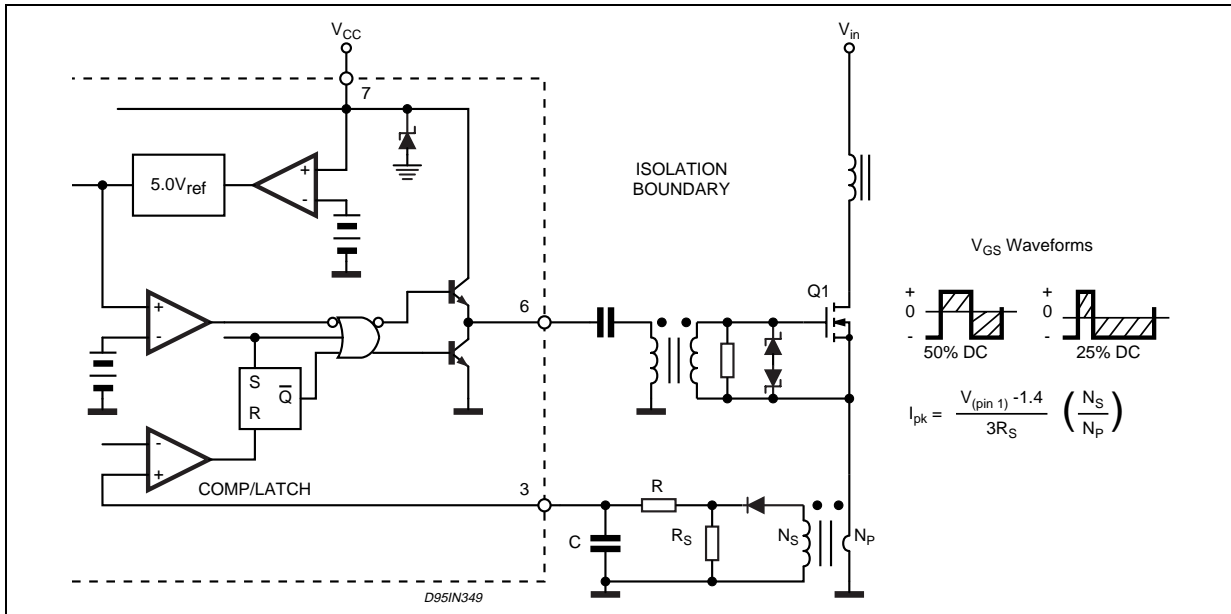

Figure 22. Latched Shutdown.

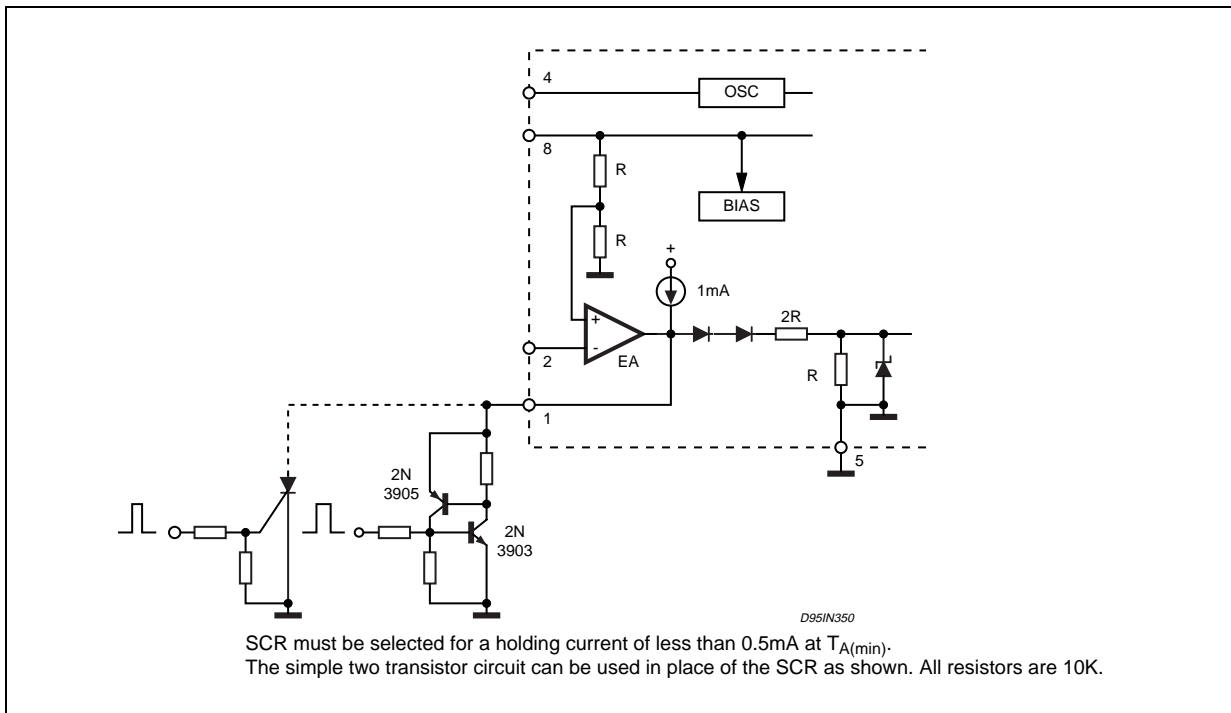

Figure 23. Error Amplifier Compensation

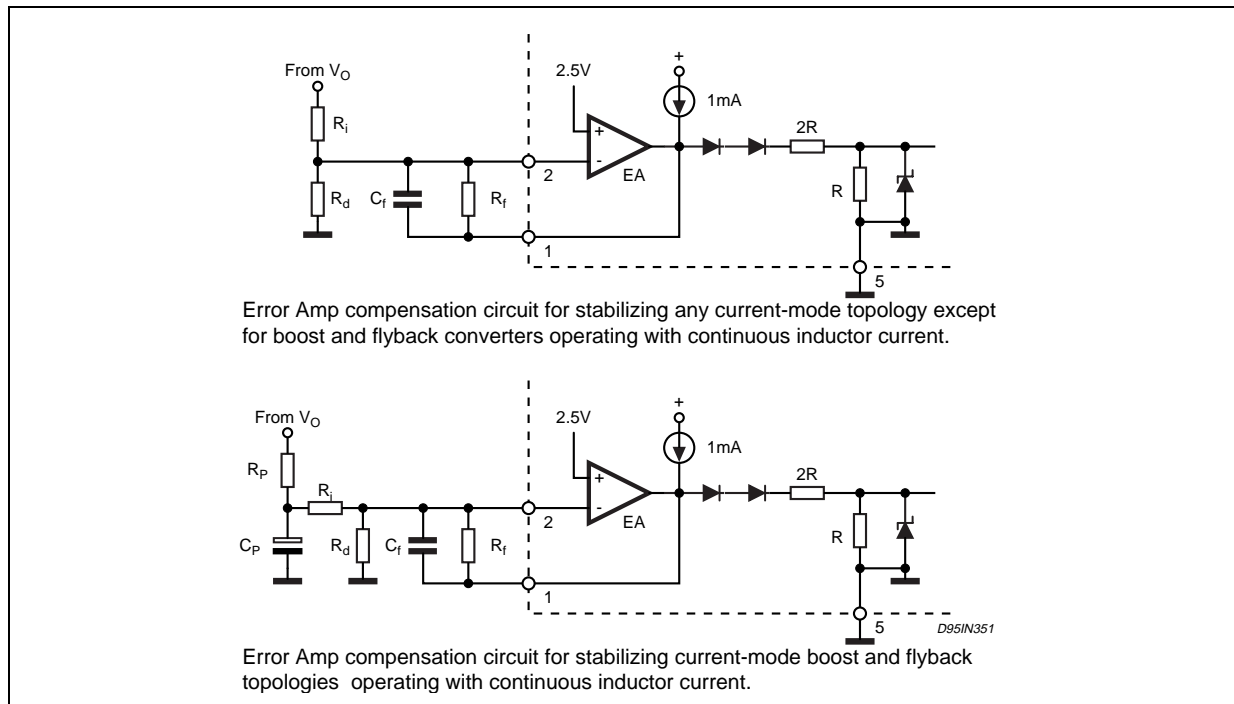

Figure 24. External Clock Synchronization.

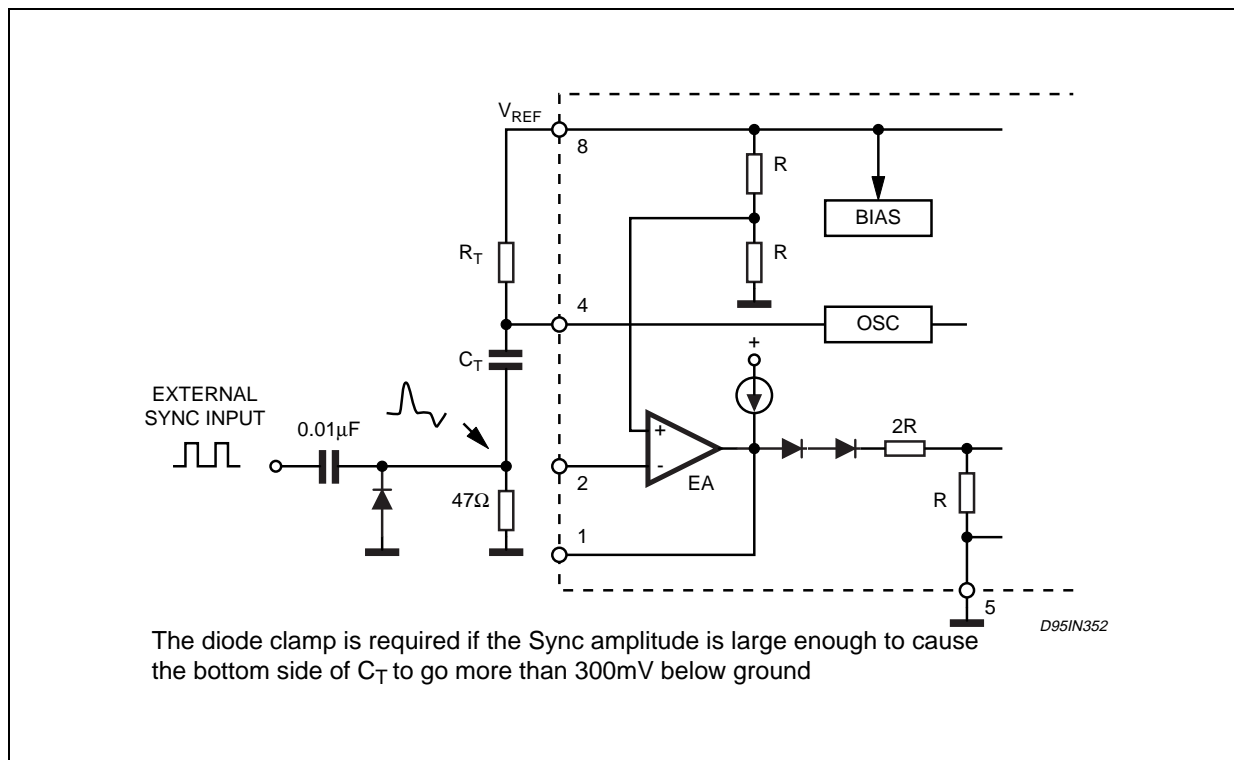

Figure 25. External Duty Cycle Clamp and Multi Unit Synchronization.

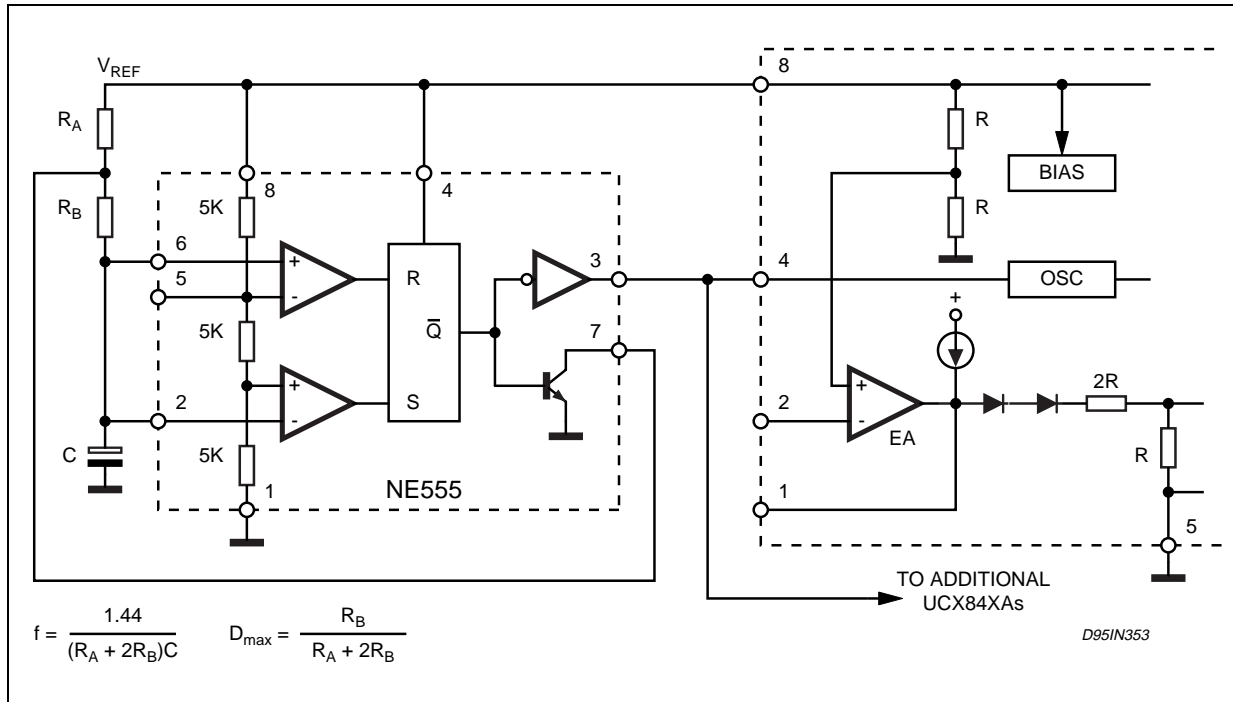

Figure 26. Soft-Start Circuit

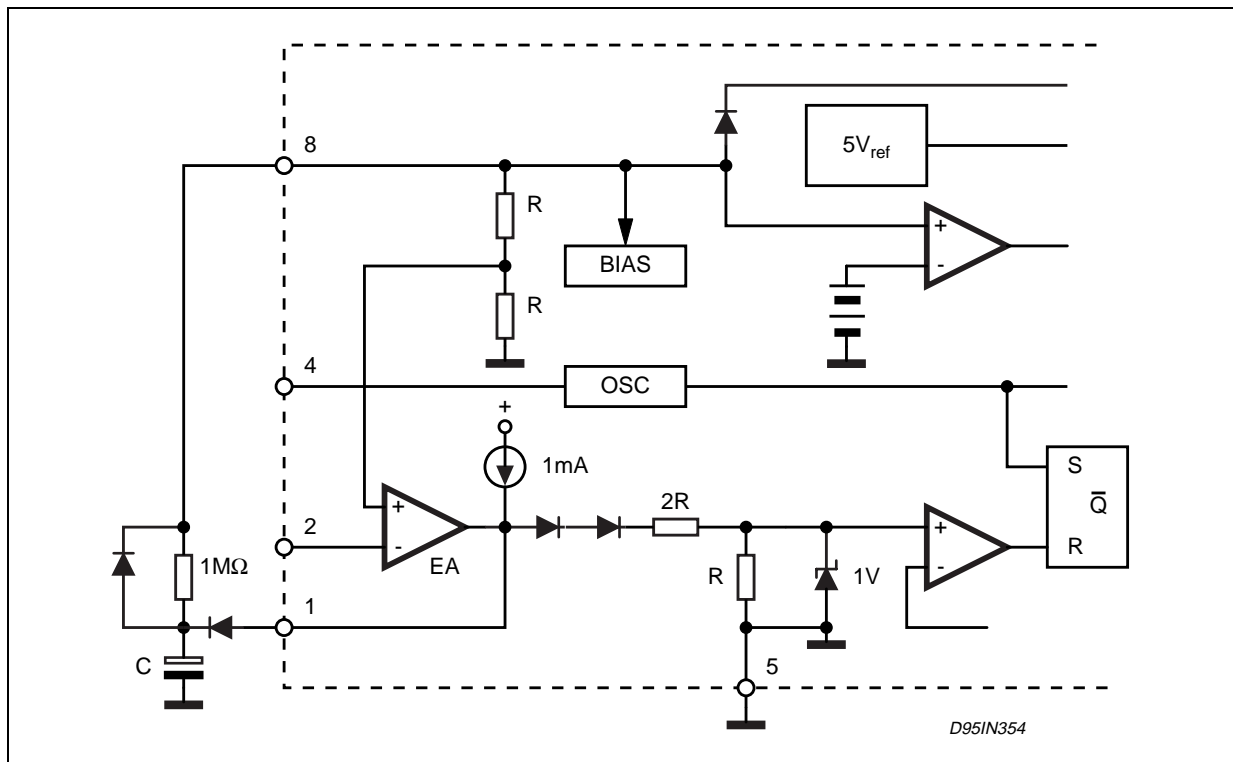

Figure 27. Soft-Start and Error Amplifier Output Duty Cycle Clamp.

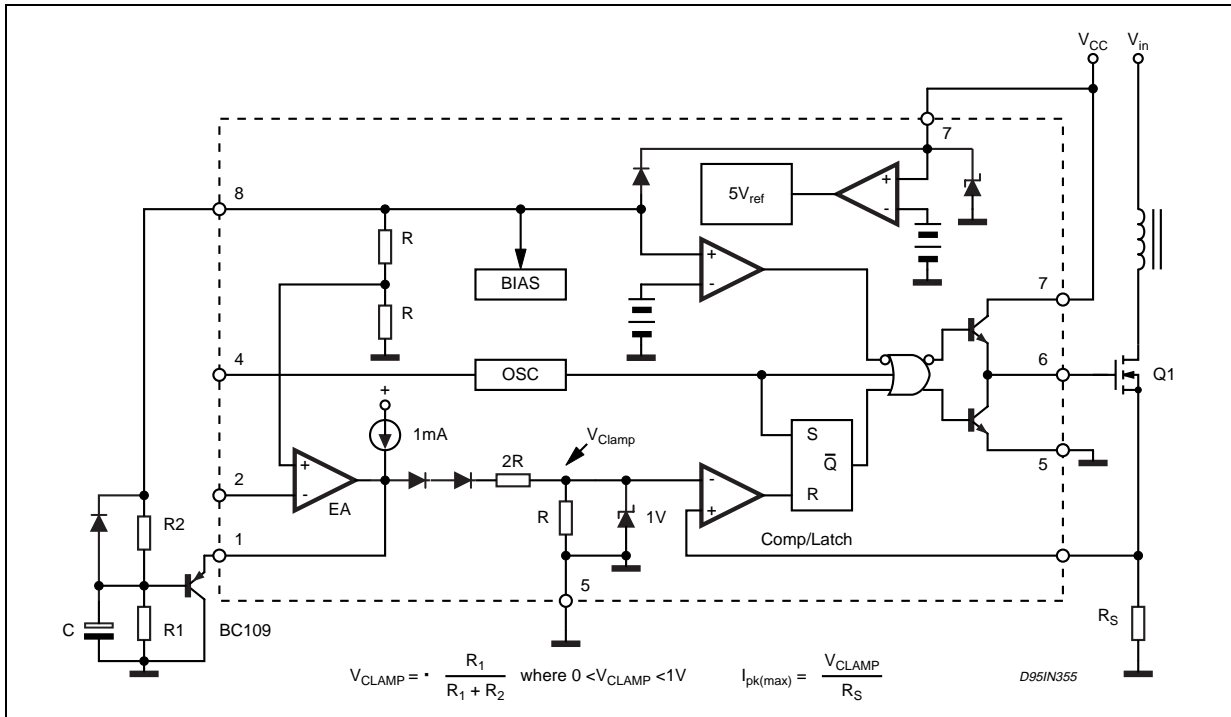
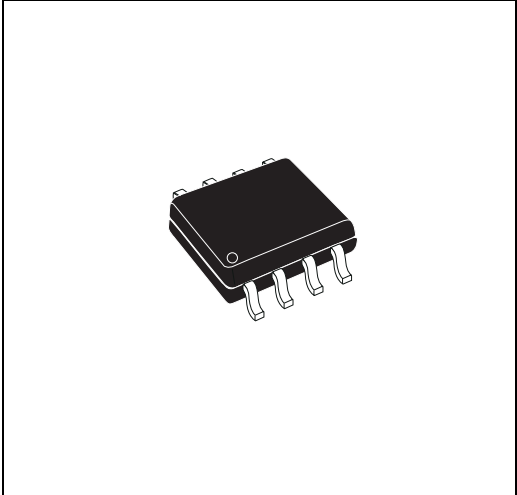

Figure 28. SO-8 Mechanical Data & Package Dimensions

DIM.	mm			inch		
	MIN.	TYP.	MAX.	MIN.	TYP.	MAX.
A	1.35		1.75	0.053		0.069
A1	0.10		0.25	0.004		0.010
A2	1.10		1.65	0.043		0.065
B	0.33		0.51	0.013		0.020
C	0.19		0.25	0.007		0.010
D (1)	4.80		5.00	0.189		0.197
E	3.80		4.00	0.15		0.157
e		1.27			0.050	
H	5.80		6.20	0.228		0.244
h	0.25		0.50	0.010		0.020
L	0.40		1.27	0.016		0.050
k	0° (min.), 8° (max.)					
ddd			0.10			0.004

Note: (1) Dimensions D does not include mold flash, protrusions or gate burrs.  
 Mold flash, protrusions or gate burrs shall not exceed 0.15mm (.006inch) in total (both side).

**OUTLINE AND MECHANICAL DATA**



**SO-8**

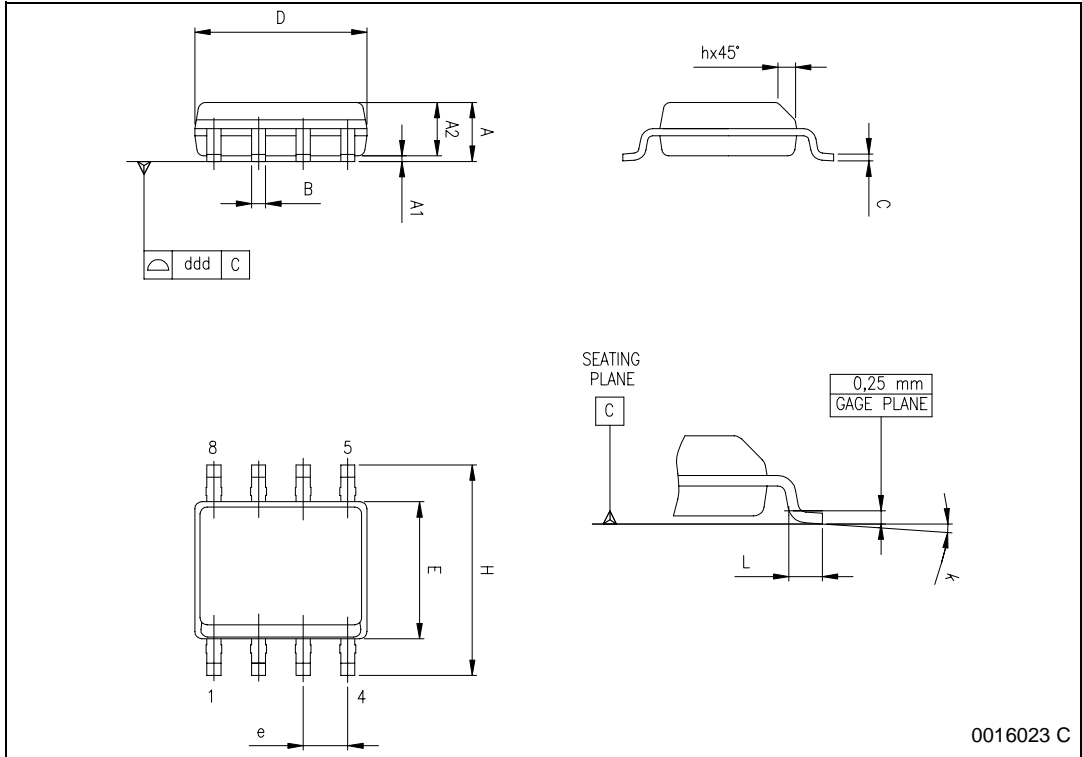

0016023 C

Figure 29. DIP-8 Mechanical Data & Package Dimensions

DIM.	mm			inch		
	MIN.	TYP.	MAX.	MIN.	TYP.	MAX.
A		3.32			0.131	
a1	0.51			0.020		
B	1.15		1.65	0.045		0.065
b	0.356		0.55	0.014		0.022
b1	0.204		0.304	0.008		0.012
D			10.92			0.430
E	7.95		9.75	0.313		0.384
e		2.54			0.100	
e3		7.62			0.300	
e4		7.62			0.300	
F			6.6			0.260
I			5.08			0.200
L	3.18		3.81	0.125		0.150
Z			1.52			0.060

OUTLINE AND MECHANICAL DATA

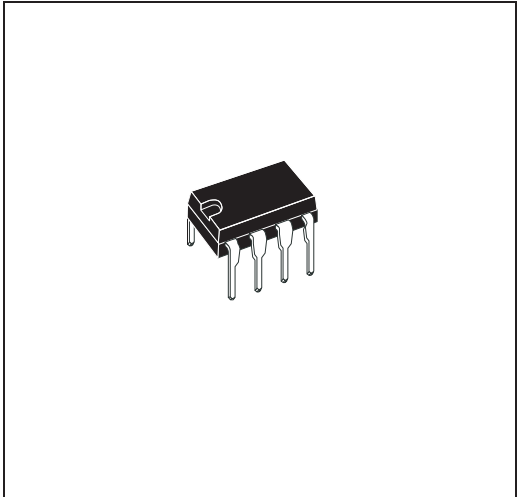

DIP-8

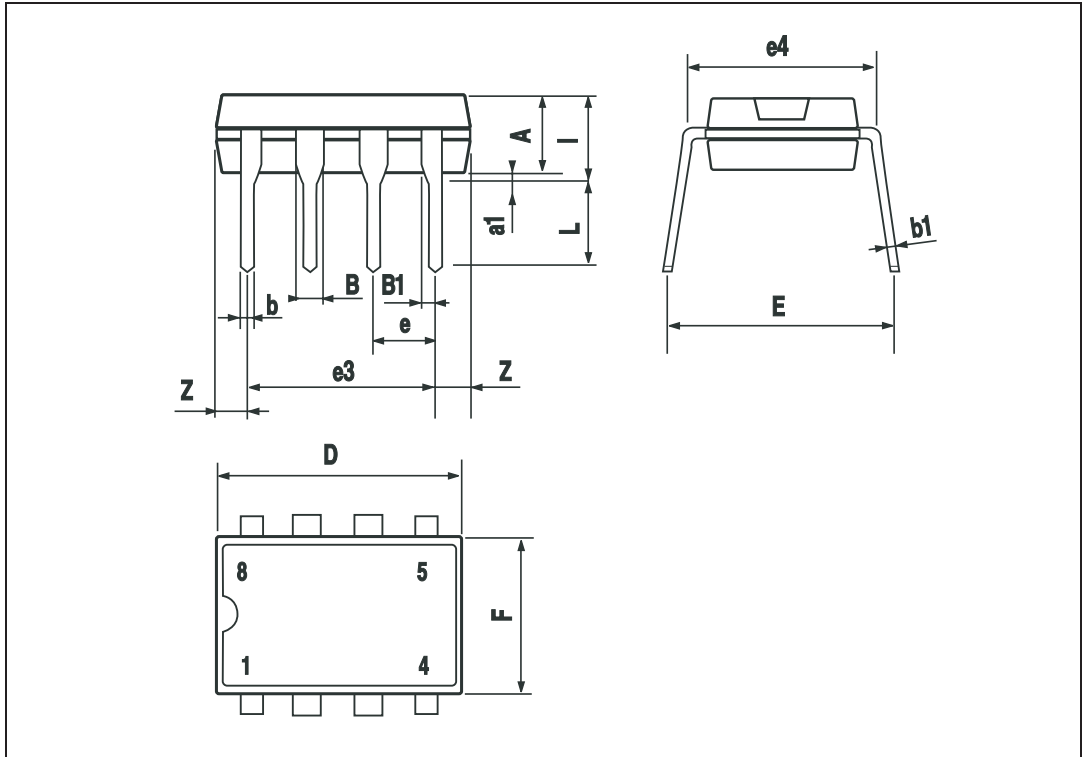

**Table 6. Revision History**

<b>Date</b>	<b>Revision</b>	<b>Description of Changes</b>
March 1999	4	First Issue in EDOCS
May 2004	5	NOT FOR NEW DESIGN

Information furnished is believed to be accurate and reliable. However, STMicroelectronics assumes no responsibility for the consequences of use of such information nor for any infringement of patents or other rights of third parties which may result from its use. No license is granted by implication or otherwise under any patent or patent rights of STMicroelectronics. Specifications mentioned in this publication are subject to change without notice. This publication supersedes and replaces all information previously supplied. STMicroelectronics products are not authorized for use as critical components in life support devices or systems without express written approval of STMicroelectronics.

The ST logo is a registered trademark of STMicroelectronics.  
All other names are the property of their respective owners

© 2004 STMicroelectronics - All rights reserved



**STMicroelectronics GROUP OF COMPANIES**

Australia - Belgium - Brazil - Canada - China - Czech Republic - Finland - France - Germany - Hong Kong - India - Israel - Italy - Japan -  
Malaysia - Malta - Morocco - Singapore - Spain - Sweden - Switzerland - United Kingdom - United States

**[www.st.com](http://www.st.com)**

## Looking for pricing, stock, or lifecycle information?

Click below to explore more details on WIN SOURCE:

-  [View UC3844AD1](#) on WIN SOURCE
-  [STMicroelectronics](#) Information

## Optimize Your Supply Chain with WIN SOURCE Solutions

-  Global Sourcing Solution
-  Obsolete Management
-  Cost Control Management
-  Shortage Management
-  Alternative Solution
-  Excess Inventory Management