



THE DATASHEET OF UC3709N



- 1.5 Amp Source/Sink Drive
- Pin Compatible with 0026 Products
- 40 ns Rise and Fall into 1000pF
- Low Quiescent Current
- 5 V to 40 V Operation
- Thermal Protection

description

The UC3709 family of power drivers is an effective low-cost solution to the problem of providing fast turn-on and off for the capacitive gates of power MOSFETs. Made with a high-speed Schottky process, these devices will provide up to 1.5 A of either source or sink current from a totem-pole output stage configured for minimal cross-conduction current spike.

The UC3709 is pin compatible with the MMH0026 or DS0026, and while the delay times are longer, the supply current is much less than these older devices.

With inverting logic, these units feature complete TTL compatibility at the inputs with an output stage that can swing over 30 V. This design also includes thermal shutdown protection.

simplified schematic (only one driver shown)

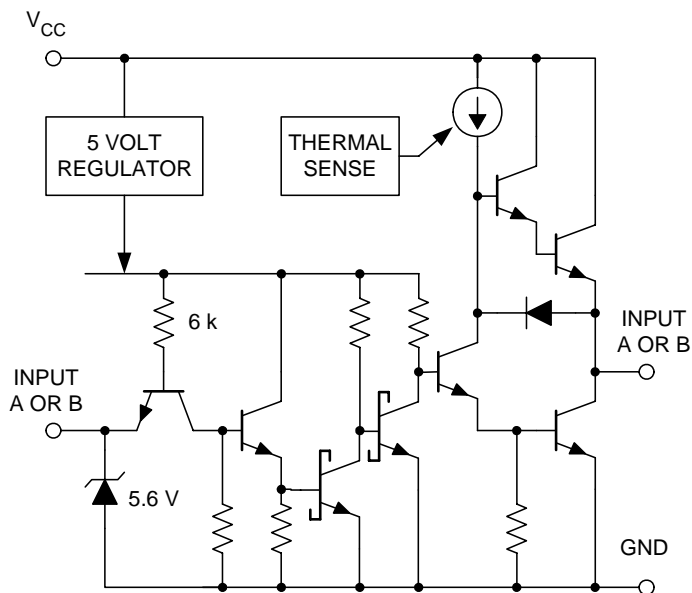

UDG-00068

absolute maximum ratings over operating free-air temperature range (unless otherwise noted)^{†‡}

Parameter	DW PACKAGE	J PACKAGE	L PACKAGE	N PACKAGE	UNIT
Supply Voltage, V _{CC}	40	40	40	40	V
Output Current (Source or Sink)					
..... Steady-State	±500	±500	±500	±500	mA
..... Peak Transient	±1.5	±1.0	±1.0	±1.5	A
..... Capacitive Discharge Energy	20	15	15	20	mJ
Digital Inputs [‡]	5.5	5.5	5.5	5.5	V
Power Dissipation at T _A = 25°C	1	1	1	1	W
Power Dissipation at T _C = 25°C	3	2	2	3	W
Operating Junction Temperature Range (T _J)	-55 to 125	-55 to 125	-55 to 125	-55 to 125	°C
Storage Temperature Range	-65 to 150	-65 to 150	-65 to 150	-65 to 150	°C
Lead Temperature (Soldering, 10 Seconds)	300	300	300	300	°C

[†] Stresses beyond those listed under "absolute maximum ratings" may cause permanent damage to the device. These are stress ratings only, and functional operation of the device at these or any other conditions beyond those indicated under "recommended operating conditions" is not implied. Exposure to absolute-maximum-rated conditions for extended periods may affect device reliability.

[‡] All currents are positive into and negative out of the specified terminals. Digital drive can exceed 5.5V if input is limited to 10mA. Consult the Packaging Section of the Databook for thermal limitations and considerations of the package.



Please be aware that an important notice concerning availability, standard warranty, and use in critical applications of Texas Instruments semiconductor products and disclaimers thereto appears at the end of this data sheet.

PRODUCTION DATA information is current as of publication date. Products conform to specifications per the terms of Texas Instruments standard warranty. Production processing does not necessarily include testing of all parameters.

UC1709, UC2709, UC3709 DUAL HIGH-SPEED FET DRIVER

SLUS196C - NOVEMBER 1996 - REVISED FEBRUARY 2008

THERMAL RESISTANCE TABLE

PACKAGE	$\theta_{jc} (^{\circ}\text{C}/\text{W})$	$\theta_{ja} (^{\circ}\text{C}/\text{W})$
SOIC-16 (DW)	20 ⁽¹⁾	35 to 58 ⁽³⁾
DIL-16 (J)	28 ⁽²⁾	125 to 160
LCC-16 (L)	20 ⁽²⁾	70 to 80
DIL-16 (N)	45	90 ⁽³⁾

- NOTES: (1) Specified thermal resistance is θ_{jl} (junction to lead) where noted.
 (2) θ_{jc} data values stated were derived from MIL-STD-1835B. MIL-STD-1835B states, "The baseline values shown are worst case (mean +2s) for a 60x60 mil microcircuit device silicon die and applicable for devices with die sizes up to 14400 square mils. For device die sizes greater than 14400 square mils use the following values; dual-in-line, 11 $^{\circ}\text{C}/\text{W}$; flat pack, .10 $^{\circ}\text{C}/\text{W}$; pin grid array, 10 $^{\circ}\text{C}/\text{W}$ ".
 (3) Specified θ_{ja} (junction to ambient) is for devices mounted to 5-inch² FR4 PC board with one ounce copper where noted. When resistance range is given, lower values are for 5 inch² aluminum PC board. Test PWB was 0.062 inch thick and typically used 0.635-mm trace widths for power packages and 1.3-mm trace widths for non-power packages with a 100-mil x 100-mil probe land area at the end of each trace.

**LCC-20 (TOP VIEW)
L PACKAGES**

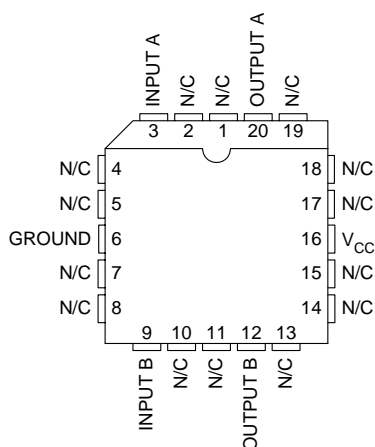

**8 PIN DIL N OR J PACKAGE
(TOP VIEW)**

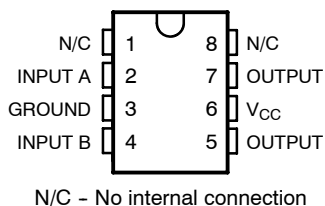

**SOIC-16 (TOP VIEW)
DW PACKAGE**

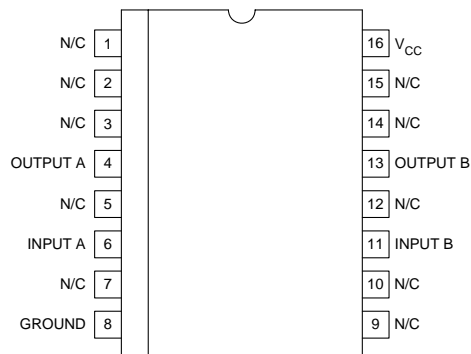

UC1709, UC2709, UC3709 DUAL HIGH-SPEED FET DRIVER

SLUS196C - NOVEMBER 1996 - REVISED FEBRUARY 2008

electrical characteristics over recommended operating free-air temperature range, $T_A = 55^\circ\text{C}$ to 125°C for the UC1709, -40°C to 85°C for the UC2709, and 0°C to 70°C for the UC3709; $V_{CC} = 20\text{ V}$, $T_A = T_J$.

PARAMETER	TEST CONDITIONS	MIN	TYP	MAX	UNIT
Supply current	Both outputs low		10	12	mA
	Both outputs high		7	10	mA
Logic 0 input voltage				0.8	V
Logic 1 input voltage		2.2			V
Input current	$V_I = 0$		-0.6	-1.0	mA
Input leakage	$V_I = 5\text{ V}$		0.05	0.1	mA
Output high saturation $V_{CC}-V_O$	$I_O = -50\text{ mA}$		1.5	2.0	V
	$I_O = -500\text{ mA}$		2.0	2.5	V
Output low saturation V_O	$I_O = 50\text{ mA}$		0.1	0.4	V
	$I_O = 500\text{ mA}$		2.0	2.5	V
Thermal shutdown			155		mA

typical switching characteristics, $V_{CC} = 20\text{ V}$, $T_A = 25^\circ\text{C}$, delays measured to 10% output change

PARAMETER	TEST CONDITIONS	OUTPUT $C_L =$		UNITS
		0 nF	2.2 nF	
Rise time delay		80	80	ns
10% to 90% rise		20	40	ns
Fall time delay		60	80	ns
10% to 90% fall		20	40	ns
VCC cross-conduction current spike duration	Output rise	25		ns
	Output fall	0		ns

NOTE: Refer to UC1705 specifications for further information.

UC1709, UC2709, UC3709 DUAL HIGH-SPEED FET DRIVER

SLUS196C - NOVEMBER 1996 - REVISED FEBRUARY 2008

APPLICATION INFORMATION

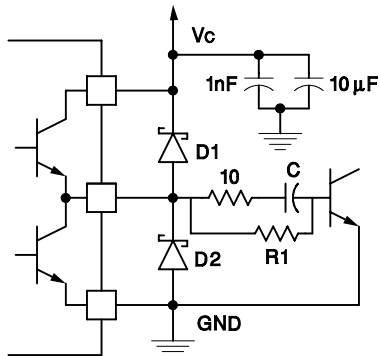

D1, D2: UC3611 Schottky Diodes

Figure 1. Power bipolar drive circuit.

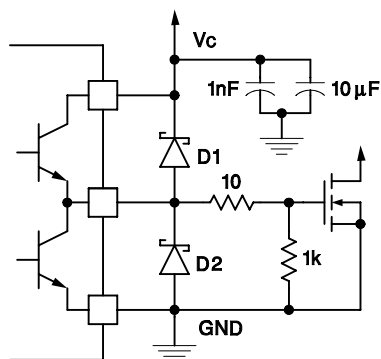

D1, D2: UC3611 Schottky Diodes

Figure 2. Power MOSFET drive circuit.

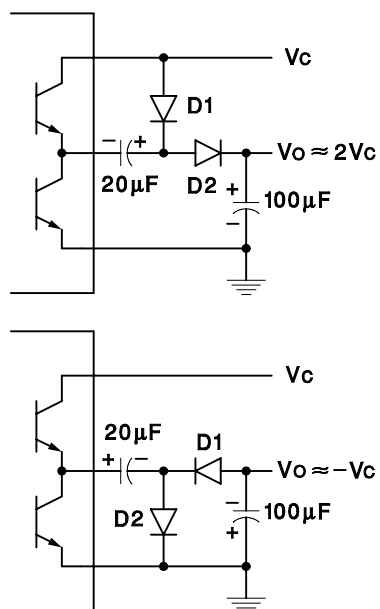

Figure 3. Charge pump circuits.

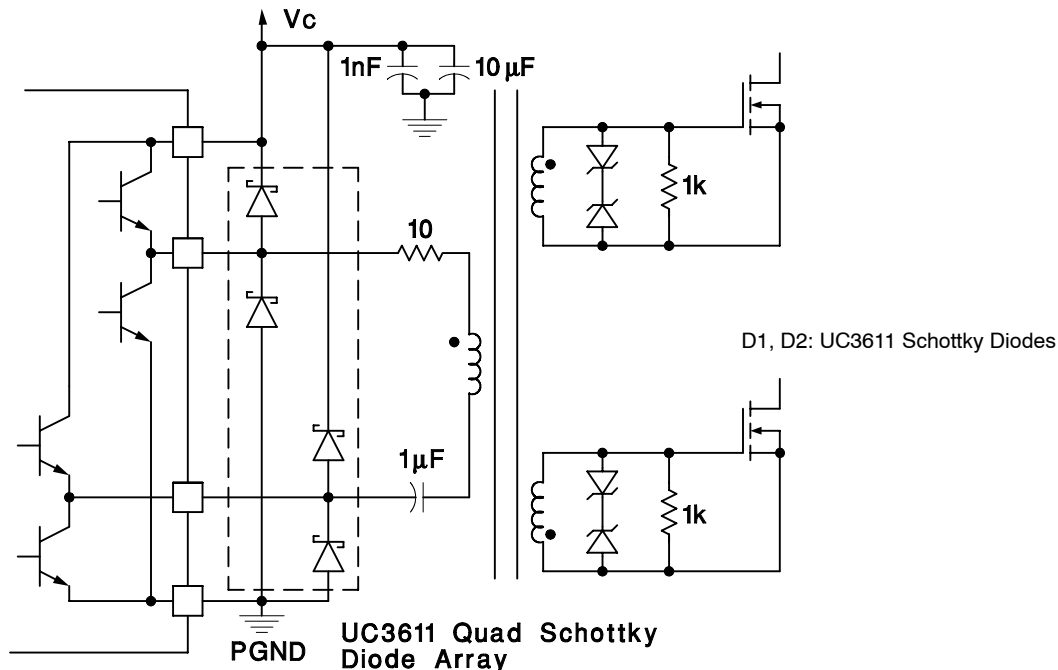

Figure 4. Transformer coupled push-pull MOSFET drive circuit.

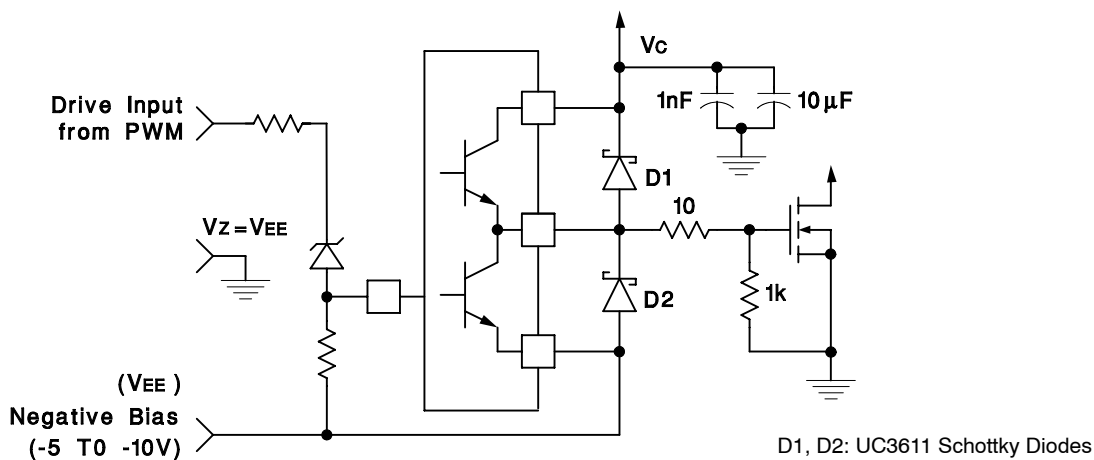

Figure 5. Power MOSFET drive circuit using negative bias voltage and level shifting to ground referenced PWM

PACKAGING INFORMATION

Orderable Device	Status (1)	Package Type	Package Drawing	Pins	Package Qty	Eco Plan (2)	Lead/Ball Finish (6)	MSL Peak Temp (3)	Op Temp (°C)	Device Marking (4/5)	Samples
5962-0151201VPA	ACTIVE	CDIP	JG	8	1	TBD	A42	N / A for Pkg Type	-55 to 125	0151201VPA UC1709	Samples
UC1709J	ACTIVE	CDIP	JG	8	1	TBD	A42	N / A for Pkg Type	-55 to 125	UC1709J	Samples
UC1709J883B	ACTIVE	CDIP	JG	8	1	TBD	A42	N / A for Pkg Type	-55 to 125	UC1709J/ 883B	Samples
UC1709L	ACTIVE	LCCC	FK	20	1	TBD	POST-PLATE	N / A for Pkg Type	-55 to 125	UC1709L	Samples
UC1709L883B	ACTIVE	LCCC	FK	20	1	TBD	POST-PLATE	N / A for Pkg Type	-55 to 125	UC1709L/ 883B	Samples
UC2709DW	ACTIVE	SOIC	DW	16	40	Green (RoHS & no Sb/Br)	CU NIPDAU	Level-2-260C-1 YEAR	-40 to 85	UC2709DW	Samples
UC2709N	ACTIVE	PDIP	P	8	50	Green (RoHS & no Sb/Br)	CU NIPDAU Call TI	N / A for Pkg Type	-40 to 85	UC2709N	Samples
UC3709DW	ACTIVE	SOIC	DW	16	40	Green (RoHS & no Sb/Br)	CU NIPDAU	Level-2-260C-1 YEAR	0 to 70	UC3709DW	Samples
UC3709N	ACTIVE	PDIP	P	8	50	Green (RoHS & no Sb/Br)	CU NIPDAU Call TI	N / A for Pkg Type	0 to 70	UC3709N	Samples
UC3709NG4	ACTIVE	PDIP	P	8	50	Green (RoHS & no Sb/Br)	Call TI	N / A for Pkg Type	0 to 70	UC3709N	Samples

(1) The marketing status values are defined as follows:

ACTIVE: Product device recommended for new designs.

LIFEBUY: TI has announced that the device will be discontinued, and a lifetime-buy period is in effect.

NRND: Not recommended for new designs. Device is in production to support existing customers, but TI does not recommend using this part in a new design.

PREVIEW: Device has been announced but is not in production. Samples may or may not be available.

OBSOLETE: TI has discontinued the production of the device.

(2) **RoHS:** TI defines "RoHS" to mean semiconductor products that are compliant with the current EU RoHS requirements for all 10 RoHS substances, including the requirement that RoHS substance do not exceed 0.1% by weight in homogeneous materials. Where designed to be soldered at high temperatures, "RoHS" products are suitable for use in specified lead-free processes. TI may reference these types of products as "Pb-Free".

RoHS Exempt: TI defines "RoHS Exempt" to mean products that contain lead but are compliant with EU RoHS pursuant to a specific EU RoHS exemption.

Green: TI defines "Green" to mean the content of Chlorine (Cl) and Bromine (Br) based flame retardants meet JS709B low halogen requirements of <=1000ppm threshold. Antimony trioxide based flame retardants must also meet the <=1000ppm threshold requirement.

(3) MSL, Peak Temp. - The Moisture Sensitivity Level rating according to the JEDEC industry standard classifications, and peak solder temperature.

(4) There may be additional marking, which relates to the logo, the lot trace code information, or the environmental category on the device.

(5) Multiple Device Markings will be inside parentheses. Only one Device Marking contained in parentheses and separated by a "~" will appear on a device. If a line is indented then it is a continuation of the previous line and the two combined represent the entire Device Marking for that device.

(6) Lead/Ball Finish - Orderable Devices may have multiple material finish options. Finish options are separated by a vertical ruled line. Lead/Ball Finish values may wrap to two lines if the finish value exceeds the maximum column width.

Important Information and Disclaimer:The information provided on this page represents TI's knowledge and belief as of the date that it is provided. TI bases its knowledge and belief on information provided by third parties, and makes no representation or warranty as to the accuracy of such information. Efforts are underway to better integrate information from third parties. TI has taken and continues to take reasonable steps to provide representative and accurate information but may not have conducted destructive testing or chemical analysis on incoming materials and chemicals. TI and TI suppliers consider certain information to be proprietary, and thus CAS numbers and other limited information may not be available for release.

In no event shall TI's liability arising out of such information exceed the total purchase price of the TI part(s) at issue in this document sold by TI to Customer on an annual basis.

OTHER QUALIFIED VERSIONS OF UC1709, UC1709-SP, UC3709 :

- Catalog: [UC3709](#), [UC1709](#)
- Military: [UC1709](#)
- Space: [UC1709-SP](#)

NOTE: Qualified Version Definitions:

- Catalog - TI's standard catalog product
- Military - QML certified for Military and Defense Applications
- Space - Radiation tolerant, ceramic packaging and qualified for use in Space-based application

FK (S-CQCC-N**)

LEADLESS CERAMIC CHIP CARRIER

28 TERMINAL SHOWN



NO. OF TERMINALS **	A		B	
	MIN	MAX	MIN	MAX
20	0.342 (8,69)	0.358 (9,09)	0.307 (7,80)	0.358 (9,09)
28	0.442 (11,23)	0.458 (11,63)	0.406 (10,31)	0.458 (11,63)
44	0.640 (16,26)	0.660 (16,76)	0.495 (12,58)	0.560 (14,22)
52	0.740 (18,78)	0.761 (19,32)	0.495 (12,58)	0.560 (14,22)
68	0.938 (23,83)	0.962 (24,43)	0.850 (21,6)	0.858 (21,8)
84	1.141 (28,99)	1.165 (29,59)	1.047 (26,6)	1.063 (27,0)



4040140/D 01/11

- NOTES:
- All linear dimensions are in inches (millimeters).
 - This drawing is subject to change without notice.
 - This package can be hermetically sealed with a metal lid.
 - Falls within JEDEC MS-004

GENERIC PACKAGE VIEW

DW 16

SOIC - 2.65 mm max height

7.5 x 10.3, 1.27 mm pitch

SMALL OUTLINE INTEGRATED CIRCUIT

This image is a representation of the package family, actual package may vary.
Refer to the product data sheet for package details.

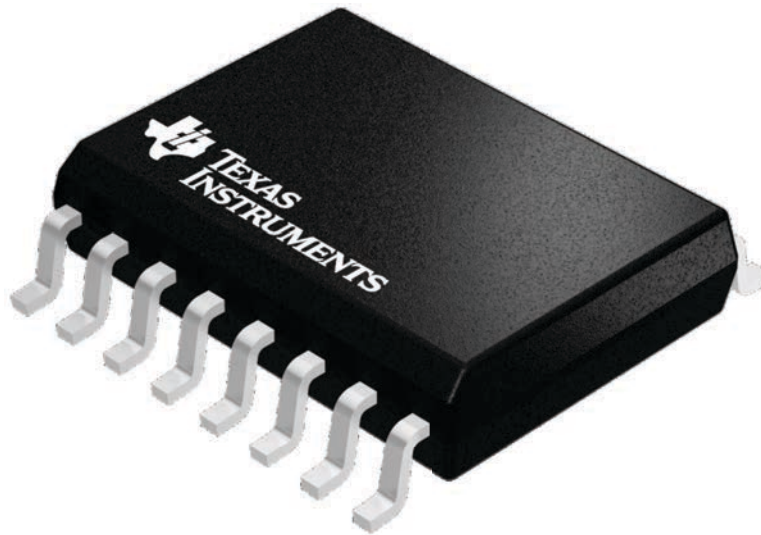

4224780/A

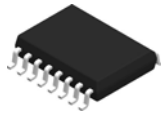

DW0016A

PACKAGE OUTLINE SOIC - 2.65 mm max height

SOIC

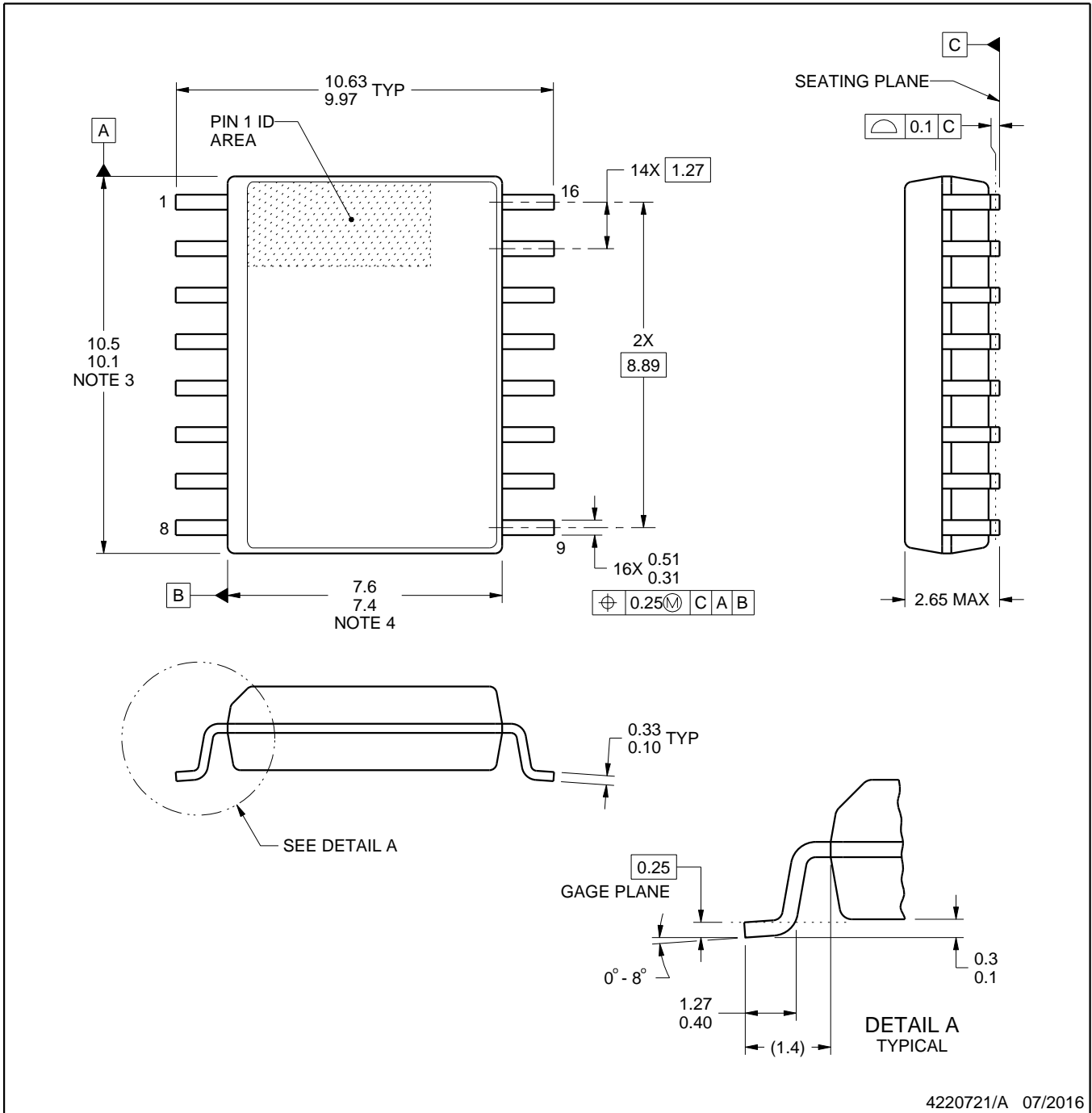

4220721/A 07/2016

NOTES:

1. All linear dimensions are in millimeters. Dimensions in parenthesis are for reference only. Dimensioning and tolerancing per ASME Y14.5M.
2. This drawing is subject to change without notice.
3. This dimension does not include mold flash, protrusions, or gate burrs. Mold flash, protrusions, or gate burrs shall not exceed 0.15 mm, per side.
4. This dimension does not include interlead flash. Interlead flash shall not exceed 0.25 mm, per side.
5. Reference JEDEC registration MS-013.

EXAMPLE BOARD LAYOUT

DW0016A

SOIC - 2.65 mm max height

SOIC

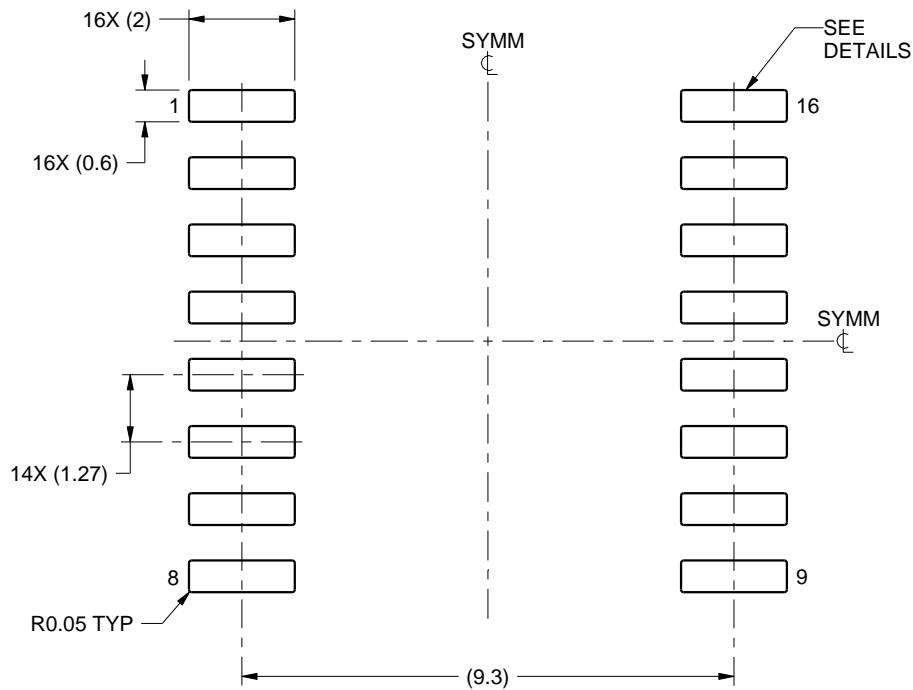

LAND PATTERN EXAMPLE
SCALE:7X

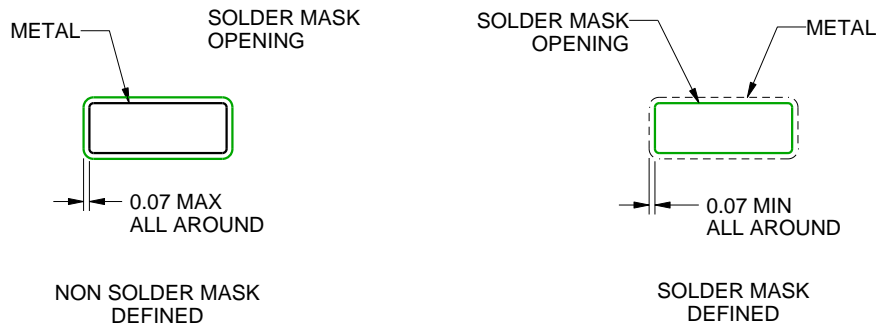

SOLDER MASK DETAILS

4220721/A 07/2016

NOTES: (continued)

6. Publication IPC-7351 may have alternate designs.

7. Solder mask tolerances between and around signal pads can vary based on board fabrication site.

EXAMPLE STENCIL DESIGN

DW0016A

SOIC - 2.65 mm max height

SOIC

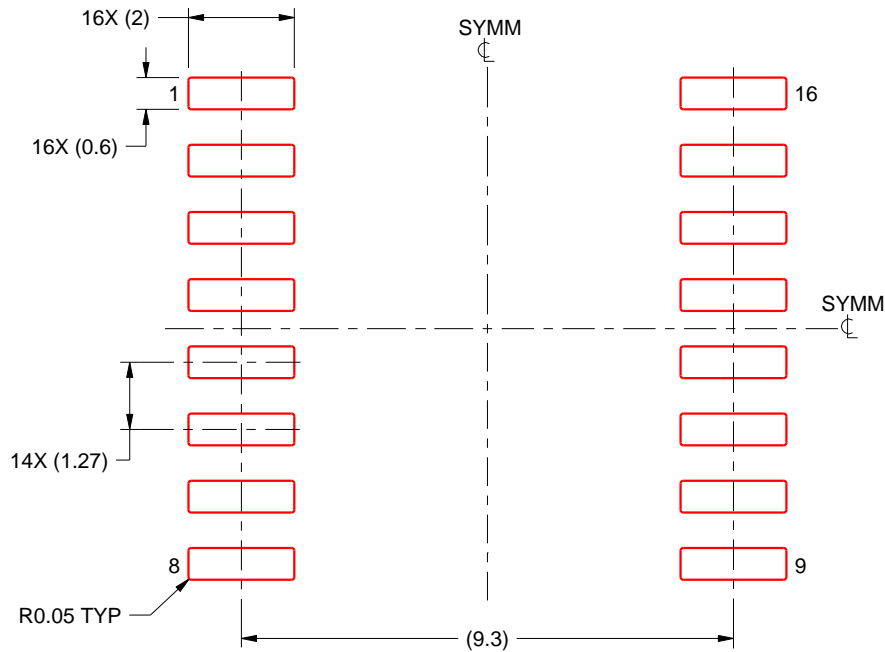

SOLDER PASTE EXAMPLE
BASED ON 0.125 mm THICK STENCIL
SCALE:7X

4220721/A 07/2016

NOTES: (continued)

8. Laser cutting apertures with trapezoidal walls and rounded corners may offer better paste release. IPC-7525 may have alternate design recommendations.
9. Board assembly site may have different recommendations for stencil design.

JG (R-GDIP-T8)

CERAMIC DUAL-IN-LINE

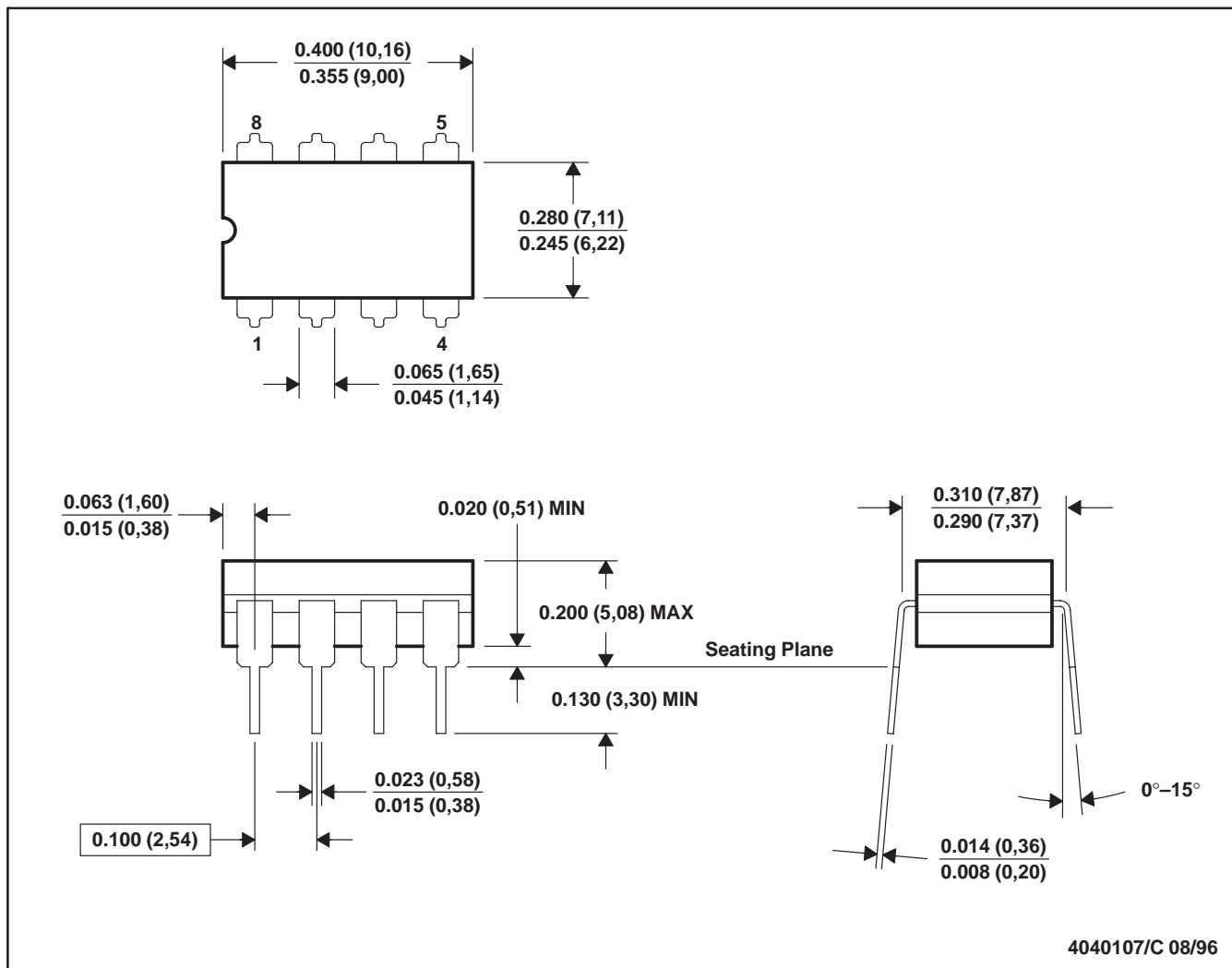

- NOTES: A. All linear dimensions are in inches (millimeters).
 B. This drawing is subject to change without notice.
 C. This package can be hermetically sealed with a ceramic lid using glass frit.
 D. Index point is provided on cap for terminal identification.
 E. Falls within MIL STD 1835 GDIP1-T8

P (R-PDIP-T8)

PLASTIC DUAL-IN-LINE PACKAGE



- NOTES:
- A. All linear dimensions are in inches (millimeters).
 - B. This drawing is subject to change without notice.
 - C. Falls within JEDEC MS-001 variation BA.

IMPORTANT NOTICE AND DISCLAIMER

TI PROVIDES TECHNICAL AND RELIABILITY DATA (INCLUDING DATASHEETS), DESIGN RESOURCES (INCLUDING REFERENCE DESIGNS), APPLICATION OR OTHER DESIGN ADVICE, WEB TOOLS, SAFETY INFORMATION, AND OTHER RESOURCES "AS IS" AND WITH ALL FAULTS, AND DISCLAIMS ALL WARRANTIES, EXPRESS AND IMPLIED, INCLUDING WITHOUT LIMITATION ANY IMPLIED WARRANTIES OF MERCHANTABILITY, FITNESS FOR A PARTICULAR PURPOSE OR NON-INFRINGEMENT OF THIRD PARTY INTELLECTUAL PROPERTY RIGHTS.



These resources are intended for skilled developers designing with TI products. You are solely responsible for (1) selecting the appropriate TI products for your application, (2) designing, validating and testing your application, and (3) ensuring your application meets applicable standards, and any other safety, security, or other requirements. These resources are subject to change without notice. TI grants you permission to use these resources only for development of an application that uses the TI products described in the resource. Other reproduction and display of these resources is prohibited. No license is granted to any other TI intellectual property right or to any third party intellectual property right. TI disclaims responsibility for, and you will fully indemnify TI and its representatives against, any claims, damages, costs, losses, and liabilities arising out of your use of these resources.

TI's products are provided subject to TI's Terms of Sale (www.ti.com/legal/termsofsale.html) or other applicable terms available either on ti.com or provided in conjunction with such TI products. TI's provision of these resources does not expand or otherwise alter TI's applicable warranties or warranty disclaimers for TI products.

Mailing Address: Texas Instruments, Post Office Box 655303, Dallas, Texas 75265
Copyright © 2019, Texas Instruments Incorporated

Looking for pricing, stock, or lifecycle information?

Click below to explore more details on WIN SOURCE:

-  [View UC3709N on WIN SOURCE](#)
-  [Texas Instruments](#) Information

Optimize Your Supply Chain with WIN SOURCE Solutions

-  Global Sourcing Solution
-  Obsolete Management
-  Cost Control Management
-  Shortage Management
-  Alternative Solution
-  Excess Inventory Management