



**THE DATASHEET OF
UC3707DWTR**



DUAL CHANNEL POWER DRIVER

FEATURES

- Two Independent Drivers
- 1.5 A Totem Pole Outputs
- Inverting and Non-Inverting Inputs
- 40 ns Rise and Fall Into 1000 pF
- High-Speed, Power MOSFET Compatible
- Low Cross-Conduction Current Spike
- Analog Shutdown With Optional Latch
- Low Quiescent Current
- 5 V to 40 V Operation
- Thermal Shutdown Protection
- 16-Pin Dual-In-Line Package
- 20-Pin PLCC and CLCC Package

DESCRIPTION

The UC1707 family of power drivers is made with a high-speed Schottky process to interface between low-level control functions and high-power switching devices—particularly power MOSFETs. These devices contain two independent channels, each of which can be activated by either a high or low input logic level signal. Each output can source or sink up to 1.5 A as long as power dissipation limits are not exceeded.

Although each output can be activated independently with its own inputs, it can be forced low in common through the action either of a digital high signal at the Shutdown terminal or a differential low-level analog signal. The Shutdown command from either source can either be latching or not, depending on the status of the Latch Disable pin.

Supply voltage for both V_{IN} and V_C can independently range from 5 V to 40 V.

These devices are available in two-watt plastic "bat-wing" DIP for operation over a 0°C to 70°C temperature range and, with reduced power, in a hermetically sealed cerdip for –55°C to +125°C operation. Also available in surface mount DW, Q, L packages.

**TRUTH TABLE
(Each Channel)⁽¹⁾**

INV.	N.I.	OUT
H	H	L
L	H	H
H	L	L
L	L	L

(1) $\overline{OUT} = \overline{INV}$ and N.I.
 $\overline{OUT} = INV$ or N.I.



Please be aware that an important notice concerning availability, standard warranty, and use in critical applications of Texas Instruments semiconductor products and disclaimers thereto appears at the end of this data sheet.

BLOCK DIAGRAM

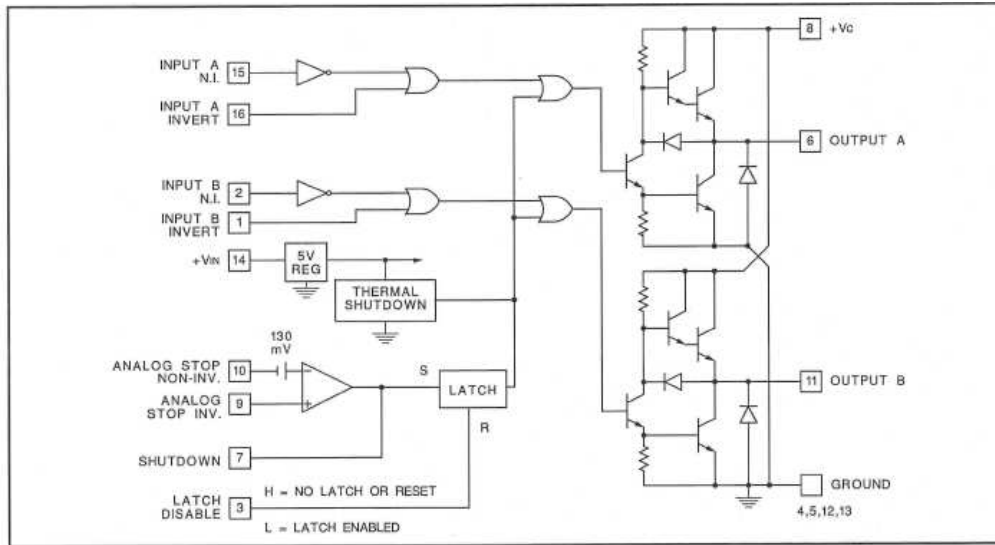

CONNECTION DIAGRAMS

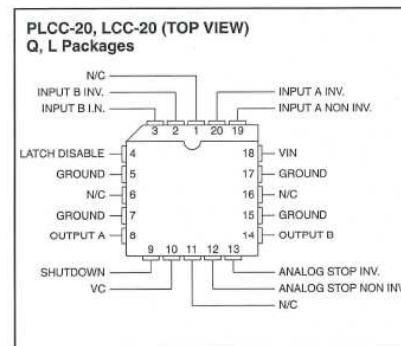
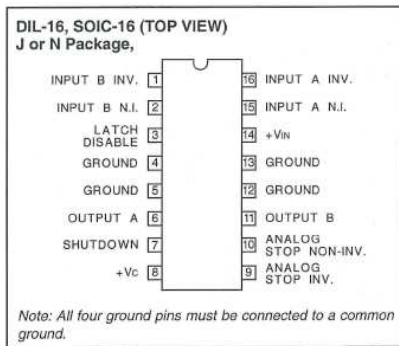

ABSOLUTE MAXIMUM RATINGS

over operating free-air temperature range (unless otherwise noted)

			MIN	MAX	UNIT
V_{IN}	Supply voltage	N/J package		40	V
V_C	Collector supply voltage	N/J package		40	V
	Output current (each output, source or sink) steady-state	N/J package		±500	mA
	Peak transient	N package		±1.5	A
		J package		±1.0	
	Capacitive discharge energy	N package		20	mJ
		J package		15	
	Digital inputs ⁽¹⁾	N/J-package		5.5	V
	Analog stop inputs	N/J package		V_{IN}	
	Power dissipation at $T_A = 25^\circ\text{C}$	N package		2	W
		J package		1	
	Power dissipation at T (leads/case) = 25°C ⁽¹⁾	N package		5	W
		J package		2	
	Operating temperature range		-55	+125	$^\circ\text{C}$
	Storage temperature range		-65	+150	$^\circ\text{C}$
	Lead temperature (soldering, 10 seconds)			300	$^\circ\text{C}$

- (1) All voltages are with respect to the four ground pins which must be connected together. All currents are positive into, negative out of the specified terminal. Digital drive can exceed 5.5 V if input current is limited to 10 mA. Consult packaging section of databook for thermal limitations and considerations of package.

ELECTRICAL CHARACTERISTICS

Unless otherwise stated, these specifications apply for $T_A = -55^\circ\text{C}$ to $+125^\circ\text{C}$ for the UC1707, -25°C to $+85^\circ\text{C}$ for the UC2707, and 0°C to $+70^\circ\text{C}$ for the UC3707; $V_{IN} = V_C = 20\text{ V}$. $T_A = T_J$.

PARAMETER		TEST CONDITIONS	MIN	TYP	MAX	UNIT
V_{IN}	Supply current	$V_{IN} = 40\text{ V}$		12	15	mA
V_C	Supply current	$V_C = 40\text{ V}$, outputs low		5.2	7.5	mA
V_C	Leakage current	$V_{IN} = 0$, $V_C = 30\text{ V}$, no load		0.05	0.1	mA
	Digital input low level				0.8	V
	Digital input high level		2.2			V
	Input current	$V_I = 0$		-0.06	-1.0	mA
	Input leakage	$V_I = 5\text{ V}$		0.05	0.1	mA
$V_C - V_O$	Output high sat.	$I_O = -50\text{ mA}$			2.0	V
		$I_O = -500\text{ mA}$			2.5	
V_O	Output low sat.	$I_O = -50\text{ mA}$			0.4	V
		$I_O = -500\text{ mA}$			2.5	
	Analog threshold	$V_{CM} = 0$ to 15 V	100	130	160	mV
	Input bias current	$V_{CM} = 0$		-10	-20	μA
	Thermal shutdown			155		$^\circ\text{C}$
	Shutdown threshold	Pin 7 input	0.4	1.0	2.2	V
	Latch disable threshold	Pin 3 input	0.8	1.2	2.2	V

TYPICAL SWITCHING CHARACTERISTICS

$V_{IN} = V_C = 20\text{ V}$, $T_A = 25^\circ\text{C}$. Delays measured to 10% output change.

PARAMETER	TEST CONDITIONS	OUTPUT CL =			UNIT
From Inv. Input to Output		open	1.0	2.2	nF
Rise time delay		40	50	60	ns
10% to 90% rise		25	40	50	ns
Fall time delay		30	40	50	ns
90% to 10% fall		25	40	50	ns
From N.I. Input to Output					
Rise time delay		30	40	50	ns
10% to 90% rise		25	40	50	ns
Fall time delay		45	55	65	ns
90% to 10% fall		25	40	50	ns
V_C cross-conduction current spike duration	Output rise	25			ns
	Output fall	0			ns
Analog shutdown delay	Stop non-Inv. = 0 V	180			ns
	Stop Inv. = 0 to 0.5 V	180			ns
Digital shutdown delay	2 V input on Pin 7	50			ns

SIMPLIFIED INTERNAL CIRCUITRY

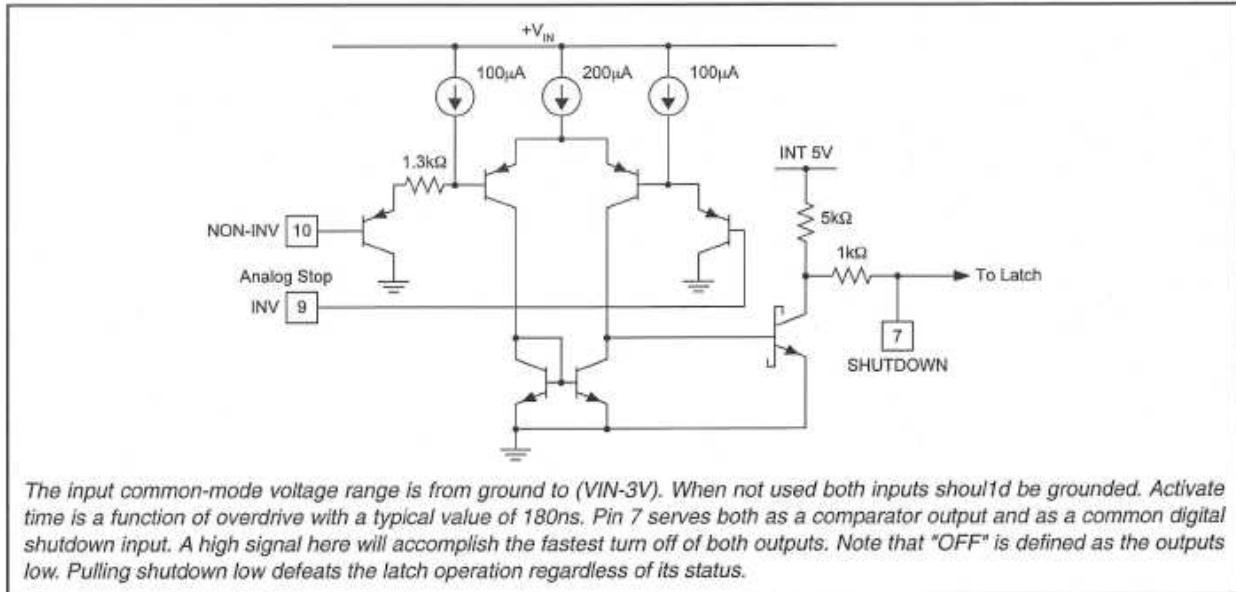

Figure 1. Typical Digital Input Gate

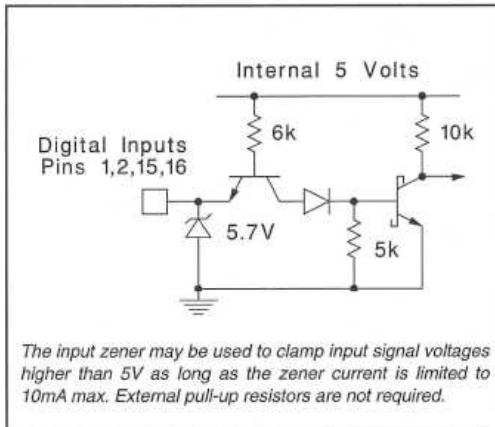

Figure 2. Typical Digital Input Gate

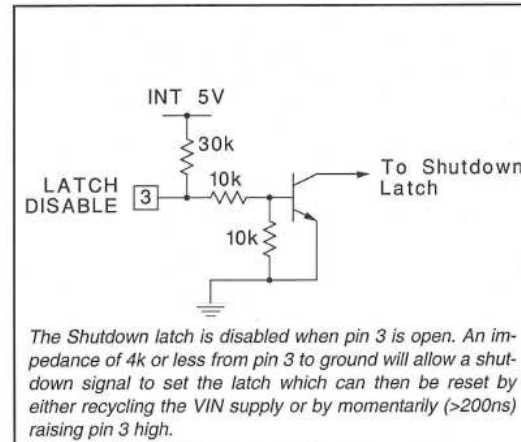

Figure 3. Latch Disable

SIMPLIFIED INTERNAL CIRCUITRY (continued)

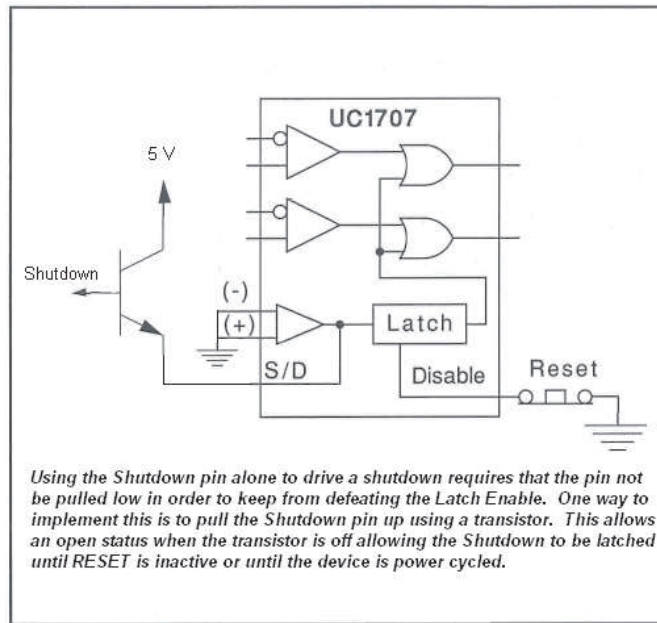

Figure 4. Use of the Shutdown Pin

SHUTDOWN CIRCUIT DESCRIPTION

The function of the circuitry is to be able to provide a shutdown of the device. This is defined as functionality that will drive both outputs to the low state. There are three different inputs that govern this shutdown capability.

- Analog Stop Pins — The differential inputs to this comparator provide a way to execute a shutdown.
- Latch Disable Pin — Assuming that the Shutdown pin is left open, a high on this pin disables the latching functionality of the Analog Stop shutdown. A low on this pin enables the latching functionality of the Analog Stop shutdown. If a shutdown occurs through the Analog Stop circuit while Latch Disable is high, then the outputs will go low, but will return to normal operation as soon as the Analog Stop circuit allows it. If a shutdown occurs through the Analog Stop circuit while Latch Disable is low, then the outputs will go low and remain low even if the Analog Stop circuit no longer drives the shutdown. The outputs will remain "latched" low (in shutdown) until the Latch Disable goes high and the Analog Stop circuit allows it to return from shutdown or the VIN voltage is cycled to 0V and then returned above 5V.
- Shutdown Pin — This pin serves two purposes.
 1. It can be used as an output of the Analog Stop circuit.
 2. It can be used as an input to force a shutdown or to force the device out of shutdown. This pin can override both the Analog Stop circuit as well as the Latch Disable Pin. When driving hard logic levels into the Shutdown pin, the Latch Disable functionality will be overridden and the Latch Disable will not function as it does when used in conjunction with the Analog Stop circuit. When the Shutdown pin is high, the outputs will be in the low state (shutdown). When the Shutdown pin is low (hard logic low) the outputs will operate normally, regardless of the state of the Latch Disable pin or the Analog Stop pins.

In order to use the Shutdown Pin with the Latch Disable functional it is necessary to use either a diode in series with the Shutdown signal or to use an open collector pull-up so that the Shutdown pin is not pulled low. This configuration will allow the Latch Disable function to work with the Shutdown pin.

SIMPLIFIED INTERNAL CIRCUITRY (continued)
UG1707 SHUTDOWN TRUTH TABLE

ANALOG STOP LOGIC	SHUTDOWN	LATCH DISABLE	PREVIOUS STATE OF OUTPUT	OUTPUT
X	0	X	X	Follows Input Logic
X	1	X	X	Low (Shutdown)
1	Open	X	X	Low (Shutdown)
0	Open	0	Shutdown	⁽¹⁾ Latched Shutdown
0	Open	0	Normal	Follows Input Logic
0	Open	1	X	Follows Input Logic

(1) If the output was previously in Shutdown and Latch Disable was low and stays low, then even if the Analog Stop Logic is changed or the Shutdown pin is open, the outputs will remain in Shutdown.

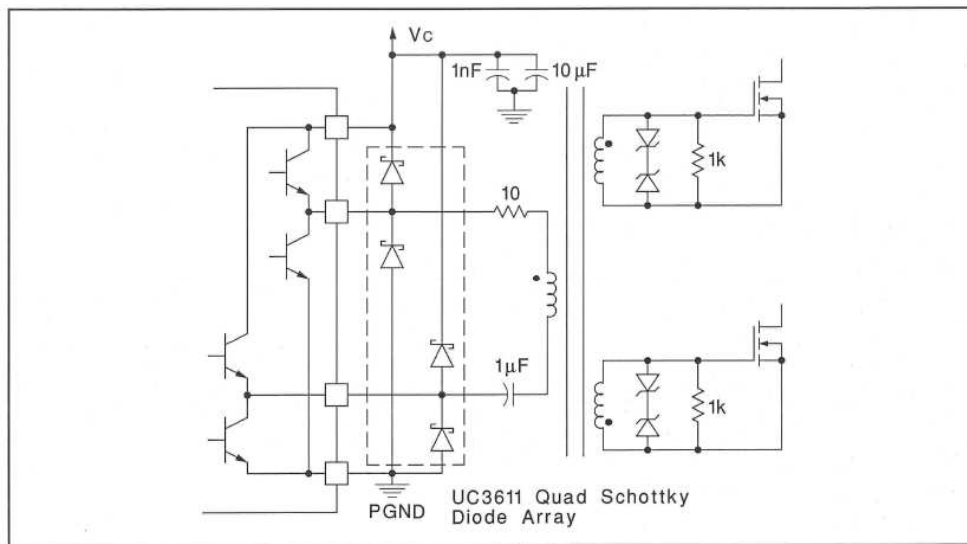

Figure 5. Transformer Coupled Push-Pull MOSFET Drive Circuit

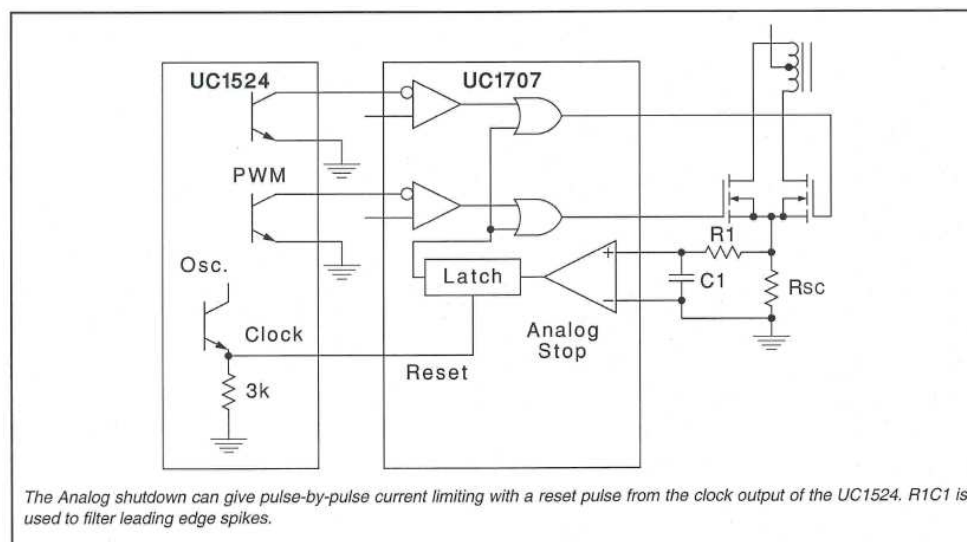

Figure 6. Current Limiting

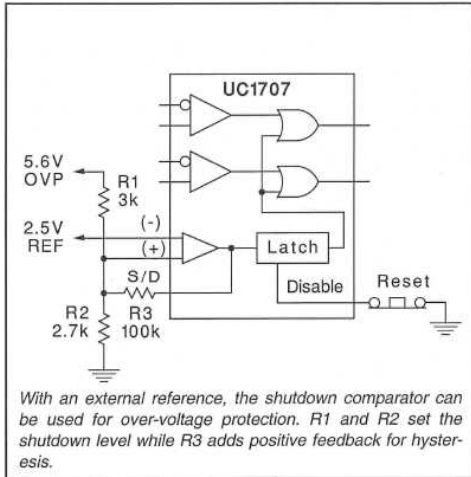

Figure 7. Over-Voltage Protection

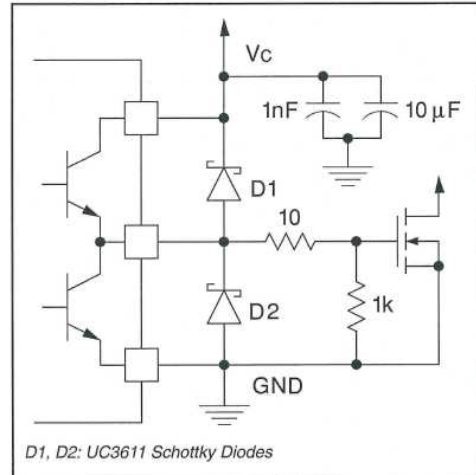

Figure 8. Power MOSFET Drive Circuit

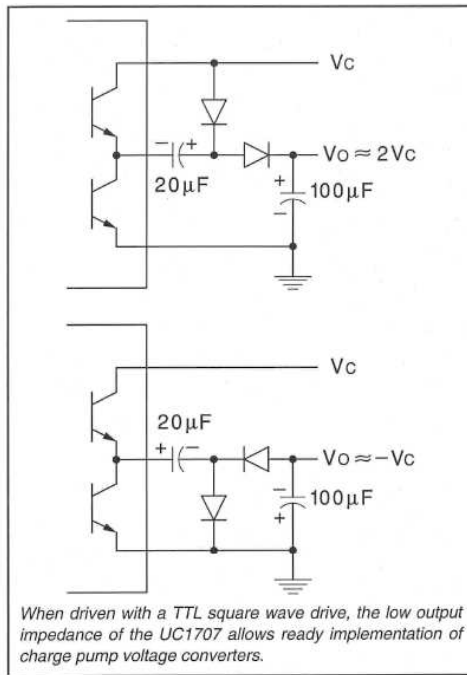

Figure 9. Charge Pump Circuits

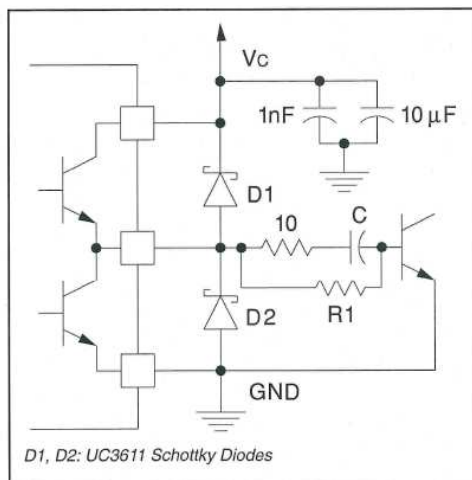

Figure 10. Power Bipolar Drive Circuit

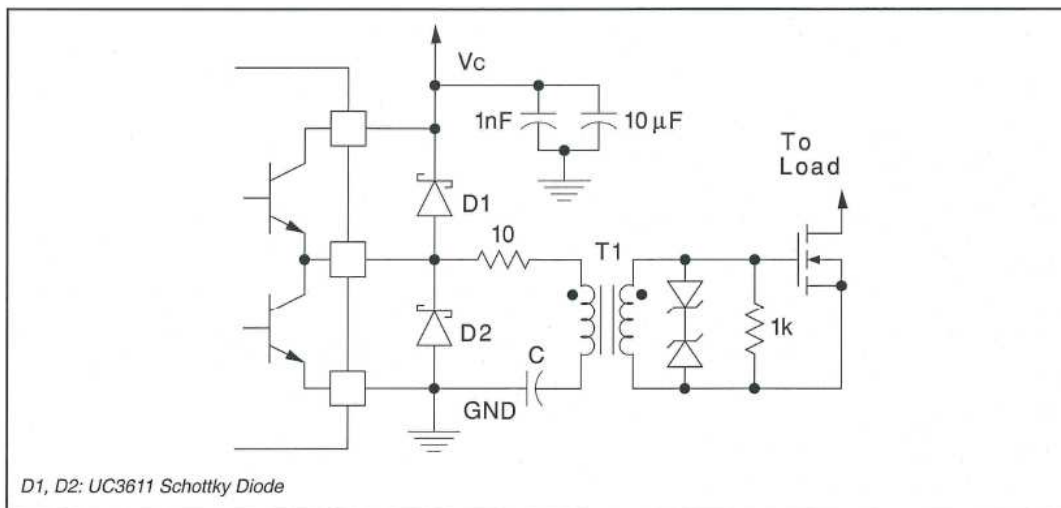

Figure 11. Transformer Coupled MOSFET Drive Circuit

PACKAGING INFORMATION

Orderable Device	Status (1)	Package Type	Package Drawing	Pins	Package Qty	Eco Plan (2)	Lead finish/ Ball material (6)	MSL Peak Temp (3)	Op Temp (°C)	Device Marking (4/5)	Samples
5962-87619012A	ACTIVE	LCCC	FK	20	55	Non-RoHS & Green	SNPB	N / A for Pkg Type	-55 to 125	5962-87619012A UC1707L/ 81032	Samples
5962-8761901EA	ACTIVE	CDIP	J	16	25	Non-RoHS & Green	SNPB	N / A for Pkg Type	-55 to 125	5962-8761901EA UC1707J/80900	Samples
5962-8761901V2A	ACTIVE	LCCC	FK	20	55	Non-RoHS & Green	SNPB	N / A for Pkg Type	-55 to 125	5962-8761901V2A UC1707L QMLV	Samples
5962-8761901VEA	ACTIVE	CDIP	J	16	25	Non-RoHS & Green	SNPB	N / A for Pkg Type	-55 to 125	5962-8761901VE A UC1707JQMLV	Samples
5962-8761903V2A	ACTIVE	LCCC	FK	20	55	Non-RoHS & Green	SNPB	N / A for Pkg Type	-55 to 125	5962-8761903V2A UC1707L-SP	Samples
5962-8761903VEA	ACTIVE	CDIP	J	16	25	Non-RoHS & Green	SNPB	N / A for Pkg Type	-55 to 125	5962-8761903VE A UC1707J-SP	Samples
5962-8761903VFA	ACTIVE	CFP	W	16	25	Non-RoHS & Green	SNPB	N / A for Pkg Type	-55 to 125	5962-8761903VF A UC1707W-SP	Samples
UC1707J	ACTIVE	CDIP	J	16	25	Non-RoHS & Green	SNPB	N / A for Pkg Type	-55 to 125	UC1707J	Samples
UC1707J883B	ACTIVE	CDIP	J	16	25	Non-RoHS & Green	SNPB	N / A for Pkg Type	-55 to 125	UC1707J/883B	Samples
UC1707L	ACTIVE	LCCC	FK	20	55	Non-RoHS & Green	SNPB	N / A for Pkg Type	-55 to 125	UC1707L	Samples
UC1707L883B	ACTIVE	LCCC	FK	20	55	Non-RoHS & Green	SNPB	N / A for Pkg Type	-55 to 125	UC1707L/ 883B	Samples
UC2707DW	ACTIVE	SOIC	DW	16	40	RoHS & Green	NIPDAU	Level-2-260C-1 YEAR	-40 to 85	UC2707DW	Samples
UC2707DWTR	ACTIVE	SOIC	DW	16	2000	RoHS & Green	NIPDAU	Level-2-260C-1 YEAR	-40 to 85	UC2707DW	Samples
UC2707N	ACTIVE	PDIP	N	16	25	RoHS & Green	NIPDAU	N / A for Pkg Type	-40 to 85	UC2707N	Samples

Orderable Device	Status (1)	Package Type	Package Drawing	Pins	Package Qty	Eco Plan (2)	Lead finish/ Ball material (6)	MSL Peak Temp (3)	Op Temp (°C)	Device Marking (4/5)	Samples
UC2707NG4	ACTIVE	PDIP	N	16	25	RoHS & Green	NIPDAU	N / A for Pkg Type	-40 to 85	UC2707N	Samples
UC3707DW	ACTIVE	SOIC	DW	16	40	RoHS & Green	NIPDAU	Level-2-260C-1 YEAR	0 to 70	UC3707DW	Samples
UC3707DWTR	ACTIVE	SOIC	DW	16	2000	RoHS & Green	NIPDAU	Level-2-260C-1 YEAR	0 to 70	UC3707DW	Samples
UC3707J	ACTIVE	CDIP	J	16	25	Non-RoHS & Green	SNPB	N / A for Pkg Type	0 to 70	UC3707J	Samples
UC3707N	ACTIVE	PDIP	N	16	25	RoHS & Green	NIPDAU	N / A for Pkg Type	0 to 70	UC3707N	Samples
UC3707NG4	ACTIVE	PDIP	N	16	25	RoHS & Green	NIPDAU	N / A for Pkg Type	0 to 70	UC3707N	Samples

(1) The marketing status values are defined as follows:

ACTIVE: Product device recommended for new designs.

LIFEBUY: TI has announced that the device will be discontinued, and a lifetime-buy period is in effect.

NRND: Not recommended for new designs. Device is in production to support existing customers, but TI does not recommend using this part in a new design.

PREVIEW: Device has been announced but is not in production. Samples may or may not be available.

OBSOLETE: TI has discontinued the production of the device.

(2) **RoHS:** TI defines "RoHS" to mean semiconductor products that are compliant with the current EU RoHS requirements for all 10 RoHS substances, including the requirement that RoHS substance do not exceed 0.1% by weight in homogeneous materials. Where designed to be soldered at high temperatures, "RoHS" products are suitable for use in specified lead-free processes. TI may reference these types of products as "Pb-Free".

RoHS Exempt: TI defines "RoHS Exempt" to mean products that contain lead but are compliant with EU RoHS pursuant to a specific EU RoHS exemption.

Green: TI defines "Green" to mean the content of Chlorine (Cl) and Bromine (Br) based flame retardants meet JS709B low halogen requirements of <=1000ppm threshold. Antimony trioxide based flame retardants must also meet the <=1000ppm threshold requirement.

(3) MSL, Peak Temp. - The Moisture Sensitivity Level rating according to the JEDEC industry standard classifications, and peak solder temperature.

(4) There may be additional marking, which relates to the logo, the lot trace code information, or the environmental category on the device.

(5) Multiple Device Markings will be inside parentheses. Only one Device Marking contained in parentheses and separated by a "~" will appear on a device. If a line is indented then it is a continuation of the previous line and the two combined represent the entire Device Marking for that device.

(6) Lead finish/Ball material - Orderable Devices may have multiple material finish options. Finish options are separated by a vertical ruled line. Lead finish/Ball material values may wrap to two lines if the finish value exceeds the maximum column width.

Important Information and Disclaimer:The information provided on this page represents TI's knowledge and belief as of the date that it is provided. TI bases its knowledge and belief on information provided by third parties, and makes no representation or warranty as to the accuracy of such information. Efforts are underway to better integrate information from third parties. TI has taken and continues to take reasonable steps to provide representative and accurate information but may not have conducted destructive testing or chemical analysis on incoming materials and chemicals. TI and TI suppliers consider certain information to be proprietary, and thus CAS numbers and other limited information may not be available for release.

In no event shall TI's liability arising out of such information exceed the total purchase price of the TI part(s) at issue in this document sold by TI to Customer on an annual basis.

OTHER QUALIFIED VERSIONS OF UC1707, UC1707-SP, UC3707, UC3707M :

- Catalog : [UC3707](#), [UC1707](#), [UC3707M](#), [UC3707](#)
- Military : [UC1707](#), [UC1707](#)
- Space : [UC1707-SP](#)

NOTE: Qualified Version Definitions:

- Catalog - TI's standard catalog product
- Military - QML certified for Military and Defense Applications
- Space - Radiation tolerant, ceramic packaging and qualified for use in Space-based application

TAPE AND REEL INFORMATION

QUADRANT ASSIGNMENTS FOR PIN 1 ORIENTATION IN TAPE



*All dimensions are nominal

Device	Package Type	Package Drawing	Pins	SPQ	Reel Diameter (mm)	Reel Width W1 (mm)	A0 (mm)	B0 (mm)	K0 (mm)	P1 (mm)	W (mm)	Pin1 Quadrant
UC2707DWTR	SOIC	DW	16	2000	330.0	16.4	10.75	10.7	2.7	12.0	16.0	Q1
UC3707DWTR	SOIC	DW	16	2000	330.0	16.4	10.75	10.7	2.7	12.0	16.0	Q1

TAPE AND REEL BOX DIMENSIONS

*All dimensions are nominal

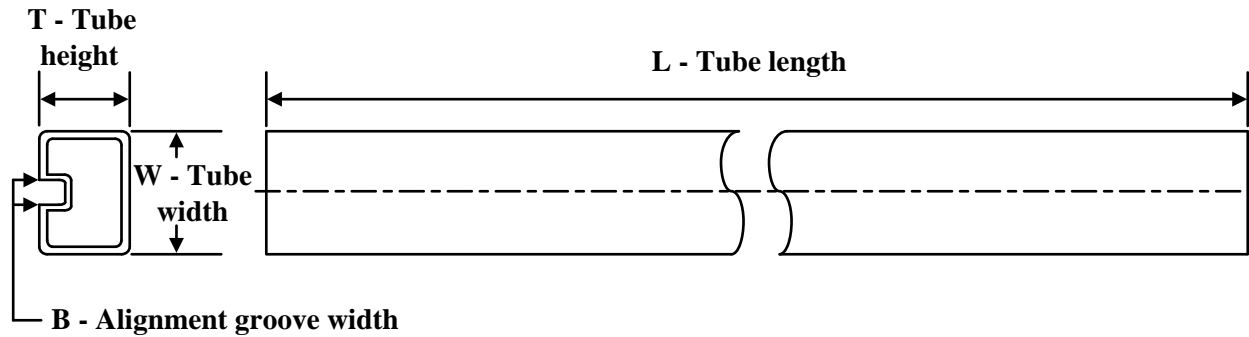
Device	Package Type	Package Drawing	Pins	SPQ	Length (mm)	Width (mm)	Height (mm)
UC2707DWTR	SOIC	DW	16	2000	356.0	356.0	35.0
UC3707DWTR	SOIC	DW	16	2000	356.0	356.0	35.0

TUBE

*All dimensions are nominal

Device	Package Name	Package Type	Pins	SPQ	L (mm)	W (mm)	T (μm)	B (mm)
5962-87619012A	FK	LCCC	20	55	506.98	12.06	2030	NA
5962-8761901V2A	FK	LCCC	20	55	506.98	12.06	2030	NA
5962-8761903V2A	FK	LCCC	20	55	506.98	12.06	2030	NA
5962-8761903VEA	J	CDIP	16	25	506.98	15.24	13440	NA
5962-8761903VFA	W	CFP	16	25	506.98	26.16	6220	NA
UC1707L	FK	LCCC	20	55	506.98	12.06	2030	NA
UC1707L883B	FK	LCCC	20	55	506.98	12.06	2030	NA
UC2707DW	DW	SOIC	16	40	507	12.83	5080	6.6
UC2707N	N	PDIP	16	25	506	13.97	11230	4.32
UC2707NG4	N	PDIP	16	25	506	13.97	11230	4.32
UC3707DW	DW	SOIC	16	40	507	12.83	5080	6.6
UC3707N	N	PDIP	16	25	506	13.97	11230	4.32
UC3707NG4	N	PDIP	16	25	506	13.97	11230	4.32

IMPORTANT NOTICE AND DISCLAIMER

TI PROVIDES TECHNICAL AND RELIABILITY DATA (INCLUDING DATA SHEETS), DESIGN RESOURCES (INCLUDING REFERENCE DESIGNS), APPLICATION OR OTHER DESIGN ADVICE, WEB TOOLS, SAFETY INFORMATION, AND OTHER RESOURCES "AS IS" AND WITH ALL FAULTS, AND DISCLAIMS ALL WARRANTIES, EXPRESS AND IMPLIED, INCLUDING WITHOUT LIMITATION ANY IMPLIED WARRANTIES OF MERCHANTABILITY, FITNESS FOR A PARTICULAR PURPOSE OR NON-INFRINGEMENT OF THIRD PARTY INTELLECTUAL PROPERTY RIGHTS.

These resources are intended for skilled developers designing with TI products. You are solely responsible for (1) selecting the appropriate TI products for your application, (2) designing, validating and testing your application, and (3) ensuring your application meets applicable standards, and any other safety, security, regulatory or other requirements.

These resources are subject to change without notice. TI grants you permission to use these resources only for development of an application that uses the TI products described in the resource. Other reproduction and display of these resources is prohibited. No license is granted to any other TI intellectual property right or to any third party intellectual property right. TI disclaims responsibility for, and you will fully indemnify TI and its representatives against, any claims, damages, costs, losses, and liabilities arising out of your use of these resources.

TI's products are provided subject to [TI's Terms of Sale](#) or other applicable terms available either on [ti.com](https://www.ti.com) or provided in conjunction with such TI products. TI's provision of these resources does not expand or otherwise alter TI's applicable warranties or warranty disclaimers for TI products.

TI objects to and rejects any additional or different terms you may have proposed.

Mailing Address: Texas Instruments, Post Office Box 655303, Dallas, Texas 75265
Copyright © 2024, Texas Instruments Incorporated

Looking for pricing, stock, or lifecycle information?

Click below to explore more details on WIN SOURCE:

 [View UC3707DWTR on WIN SOURCE](#)

 [Texas Instruments](#) Information

Optimize Your Supply Chain with WIN SOURCE Solutions

-  Global Sourcing Solution
-  Obsolete Management
-  Cost Control Management
-  Shortage Management
-  Alternative Solution
-  Excess Inventory Management