



UNIVERSAL ACTIVE FILTER

 Check for Samples: [UAF42](#)

FEATURES

- **VERSATILE:**
 - Low-Pass, High-Pass
 - Band-Pass, Band-Reject
- **SIMPLE DESIGN PROCEDURE**
- **ACCURATE FREQUENCY AND Q:**
 - Includes On-Chip 1000pF $\pm 0.5\%$ Capacitors

APPLICATIONS

- **TEST EQUIPMENT**
- **COMMUNICATIONS EQUIPMENT**
- **MEDICAL INSTRUMENTATION**
- **DATA ACQUISITION SYSTEMS**
- **MONOLITHIC REPLACEMENT FOR UAF41**

DESCRIPTION

The UAF42 is a universal active filter that can be configured for a wide range of low-pass, high-pass, and band-pass filters. It uses a classic state-variable analog architecture with an inverting amplifier and two integrators. The integrators include on-chip 1000pF capacitors trimmed to 0.5%. This architecture solves one of the most difficult problems of active filter design—obtaining tight tolerance, low-loss capacitors.

A DOS-compatible filter design program allows easy implementation of many filter types, such as Butterworth, Bessel, and Chebyshev. A fourth, uncommitted FET-input op amp (identical to the other three) can be used to form additional stages, or for special filters such as band-reject and Inverse Chebyshev.

The classical topology of the UAF42 forms a time-continuous filter, free from the anomalies and switching noise associated with switched-capacitor filter types.

The UAF42 is available in 14-pin plastic DIP and SOIC-16 surface-mount packages, specified for the -25°C to $+85^{\circ}\text{C}$ temperature range.

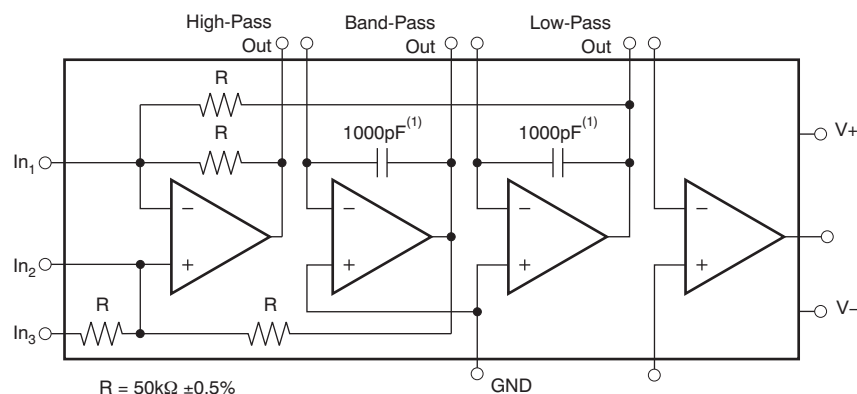

NOTE: (1) $\pm 0.5\%$.



Please be aware that an important notice concerning availability, standard warranty, and use in critical applications of Texas Instruments semiconductor products and disclaimers thereto appears at the end of this data sheet.

All trademarks are the property of their respective owners.



This integrated circuit can be damaged by ESD. Texas Instruments recommends that all integrated circuits be handled with appropriate precautions. Failure to observe proper handling and installation procedures can cause damage.

ESD damage can range from subtle performance degradation to complete device failure. Precision integrated circuits may be more susceptible to damage because very small parametric changes could cause the device not to meet its published specifications.

ABSOLUTE MAXIMUM RATINGS⁽¹⁾

Over operating free-air temperature range unless otherwise noted.

	UAF42	UNIT
Power Supply Voltage	±18	V
Input Voltage	±V _S ±0.7	V
Output Short-Circuit	Continuous	
Operating Temperature	–40 to +85	°C
Storage Temperature	–40 to +125	°C
Junction Temperature	+125	°C

- (1) Stresses above these ratings may cause permanent damage. Exposure to absolute maximum conditions for extended period may degrade device reliability. These are stress ratings only, and functional operation of the device at these or any other conditions beyond those specified is not supported.

ORDERING INFORMATION⁽¹⁾

PRODUCT	PACKAGE-LEAD	PACKAGE DESIGNATOR	PACKAGE MARKING
UAF42AP	PDIP-14	N	UAF42AP
UAF42APG4			
UAF42AU	SOIC-16	DW	UAF42AU
UAF42AUE4			

- (1) For the most current package and ordering information see the Package Option Addendum at the end of this document, or see the TI web site at www.ti.com.

PIN CONFIGURATIONS

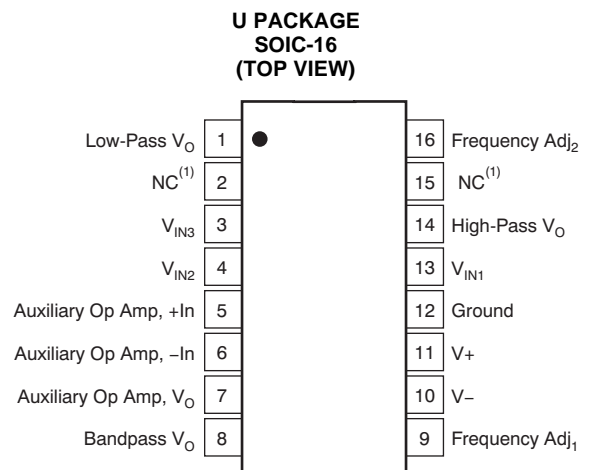
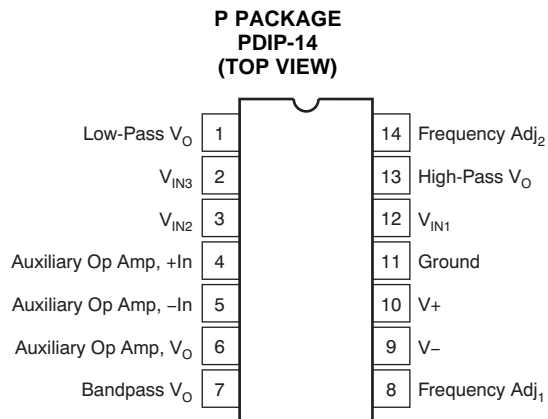

NOTE: (1) NC = no connection. For best performance connect all NC pins to ground to minimize inter-lead capacitance.

ELECTRICAL CHARACTERISTICS

 At $T_A = +25^\circ\text{C}$, and $V_S = \pm 15\text{V}$, unless otherwise noted.

PARAMETER	CONDITIONS	UAF42AP, AU			UNIT
		MIN	TYP	MAX	
FILTER PERFORMANCE					
Frequency Range, f_n			0 to 100		kHz
Frequency Accuracy vs Temperature	$f = 1\text{kHz}$		0.01	1	%
Maximum Q			400		—
Maximum (Q • Frequency) Product			500		kHz
Q vs Temperature	$(f_O \cdot Q) < 10^4$		0.01		%/°C
	$(f_O \cdot Q) < 10^5$		0.025		%/°C
Q Repeatability	$(f_O \cdot Q) < 10^5$		2		%
Offset Voltage, Low-Pass Output				±5	mV
Resistor Accuracy			0.5	1	%
OFFSET VOLTAGE⁽¹⁾					
Input Offset Voltage vs Temperature			±0.5	±5	mV
vs Power Supply	$V_S = \pm 6\text{V to } \pm 18\text{V}$	80	96		μV/°C
INPUT BIAS CURRENT⁽¹⁾					
Input Bias Current	$V_{CM} = 0\text{V}$		10	50	pA
Input Offset Current	$V_{CM} = 0\text{V}$		5		pA
NOISE					
Input Voltage Noise					
Noise Density: $f = 10\text{Hz}$			25		nV/√Hz
Noise Density: $f = 10\text{kHz}$			10		nV/√Hz
Voltage Noise: BW = 0.1Hz to 10Hz			2		μV _{PP}
Input Bias Current Noise					
Noise Density: $f = 10\text{kHz}$			2		fA/√Hz
INPUT VOLTAGE RANGE⁽¹⁾					
Common-Mode Input Range			±11.5		V
Common-Mode Rejection	$V_{CM} = \pm 10\text{V}$	80	96		dB
INPUT IMPEDANCE⁽¹⁾					
Differential			$10^{13} \parallel 2$		Ω pF
Common-Mode			$10^{13} \parallel 6$		Ω pF
OPEN-LOOP GAIN⁽¹⁾					
Open-Loop Voltage Gain	$V_O = \pm 10\text{V}, R_L = 2\text{k}\Omega$	90	126		dB
FREQUENCY RESPONSE					
Slew Rate			10		V/μs
Gain-Bandwidth Product	$G = +1$		4		MHz
Total Harmonic Distortion	$G = +1, f = 1\text{kHz}$		0.1		%
OUTPUT⁽¹⁾					
Voltage Output	$R_L = 2\text{k}\Omega$	±11	±11.5		V
Short Circuit Current			±25		mA

(1) Specifications apply to uncommitted op amp, A_4 . The three op amps forming the filter are identical to A_4 but are tested as a complete filter.

ELECTRICAL CHARACTERISTICS (continued)At $T_A = +25^\circ\text{C}$, and $V_S = \pm 15\text{V}$, unless otherwise noted.

PARAMETER	CONDITIONS	UAF42AP, AU			UNIT
		MIN	TYP	MAX	
POWER SUPPLY					
Specified Operating Voltage			± 15		V
Operating Voltage Range		± 6		± 18	V
Current			± 6	± 7	mA
TEMPERATURE RANGE					
Specified		-25		$+85$	$^\circ\text{C}$
Operating		-25		$+85$	$^\circ\text{C}$
Storage		-40		$+125$	$^\circ\text{C}$
Thermal Resistance, θ_{JA}			100		$^\circ\text{C/W}$

APPLICATION INFORMATION

The UAF42 is a monolithic implementation of the proven state-variable analog filter topology. This device is pin-compatible with the popular UAF41 analog filter, and it provides several improvements.

The slew rate of the UAF42 has been increased to 10V/μs, versus 1.6V/μs for the UAF41. Frequency • Q product of the UAF42 has been improved, and the useful natural frequency extended by a factor of four to 100kHz. FET input op amps on the UAF42 provide very low input bias current. The monolithic construction of the UAF42 provides lower cost and improved reliability.

DESIGN PROGRAM

Application report [SBFA002](#) (available for download at www.ti.com) and a computer-aided design program also available from Texas Instruments, make it easy to design and implement many kinds of active filters. The DOS-compatible program guides you through the design process and automatically calculates component values.

Low-pass, high-pass, band-pass and band-reject (notch) filters can be designed. The program supports the three most commonly-used all-pole filter types: Butterworth, Chebyshev and Bessel. The less-familiar inverse Chebyshev is also supported, providing a smooth passband response with ripple in the stop band.

With each data entry, the program automatically calculates and displays filter performance. This feature allows a spreadsheet-like *what-if* design approach. For example, a user can quickly determine, by trial and error, how many poles are required for a desired attenuation in the stopband. Gain/phase plots may be viewed for any response type.

The basic building element of the most commonly-used filter types is the second-order section. This section provides a complex-conjugate pair of poles. The natural frequency, ω_n , and Q of the pole pair determine the characteristic response of the section. The low-pass transfer function is shown in [Equation 1](#):

$$\frac{V_O(s)}{V_I(s)} = \frac{A_{LP}\omega_n^2}{s^2 + s\omega_n/Q + \omega_n^2} \quad (1)$$

The high-pass transfer function is given by [Equation 2](#):

$$\frac{V_{HP}(s)}{V_I(s)} = \frac{A_{HP}s^2}{s^2 + s\omega_n/Q + \omega_n^2} \quad (2)$$

The band-pass transfer function is calculated using [Equation 3](#):

$$\frac{V_{BP}(s)}{V_I(s)} = \frac{A_{BP}(\omega_n/Q) s}{s^2 + s\omega_n/Q + \omega_n^2} \quad (3)$$

A band-reject response is obtained by summing the low-pass and high-pass outputs, yielding the transfer function shown in [Equation 4](#):

$$\frac{V_{BR}(s)}{V_I(s)} = \frac{A_{BR}(s^2 + \omega_n^2)}{s^2 + s\omega_n/Q + \omega_n^2} \quad (4)$$

The most common filter types are formed with one or more cascaded second-order sections. Each section is designed for ω_n and Q according to the filter type (Butterworth, Bessel, Chebyshev, etc.) and cutoff frequency. While tabulated data can be found in virtually any filter design text, the design program eliminates this tedious procedure.

Second-order sections may be noninverting ([Figure 1](#)) or inverting ([Figure 2](#)). Design equations for these two basic configurations are shown for reference. The design program solves these equations, providing complete results, including component values.

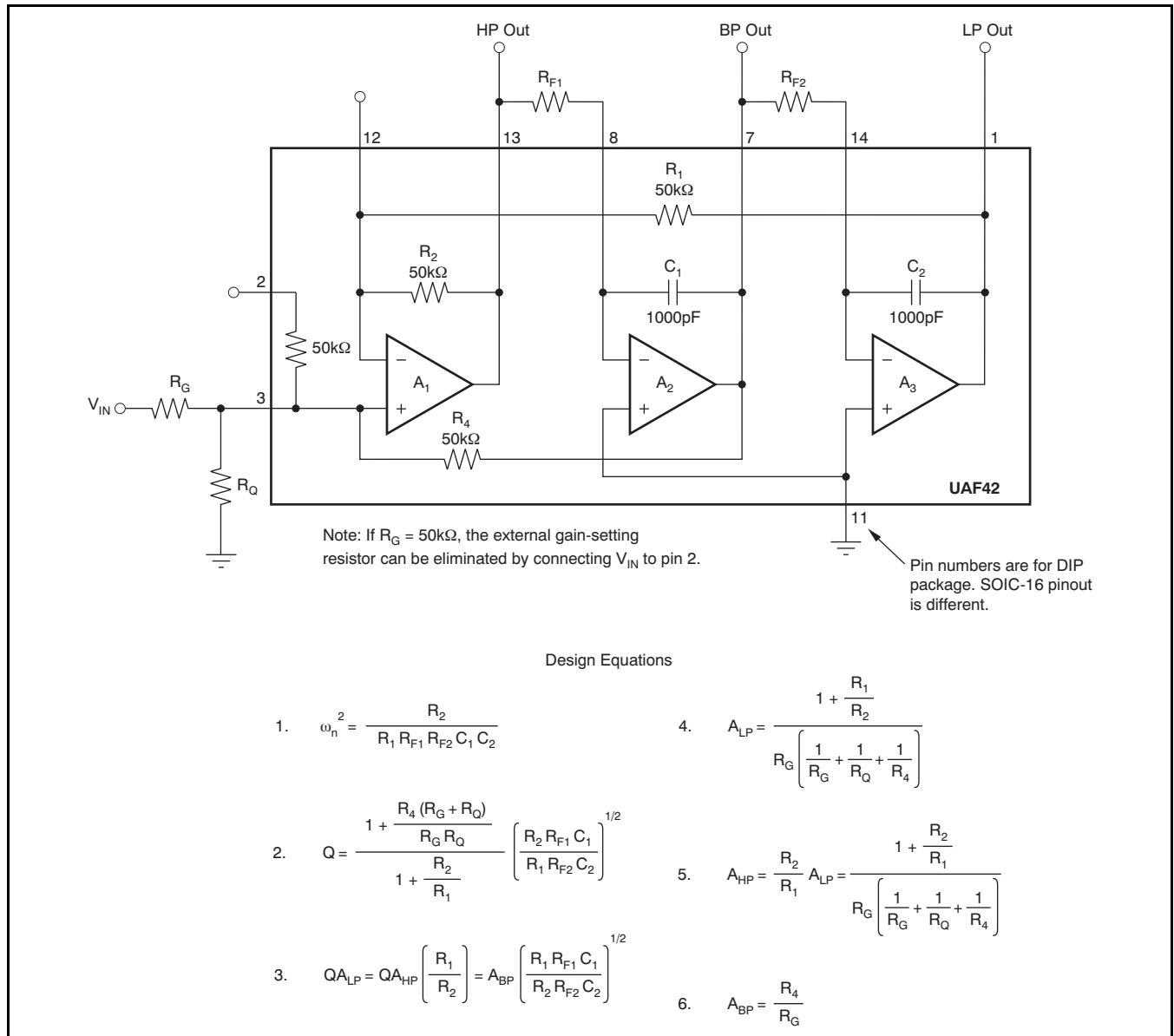

Figure 1. Noninverting Pole-Pair

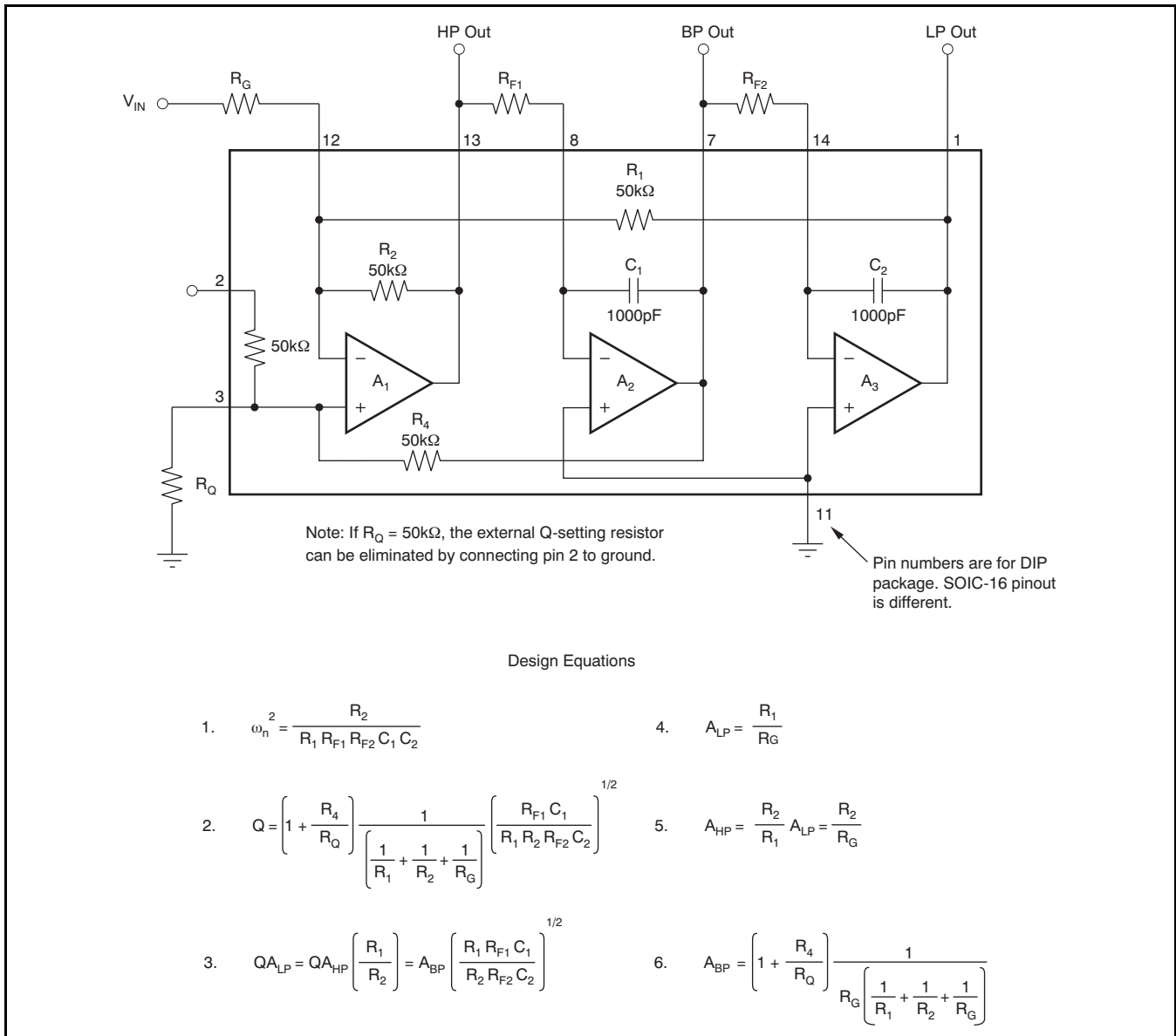

Figure 2. Inverting Pole-Pair

REVISION HISTORY

NOTE: Page numbers for previous revisions may differ from page numbers in the current version.

Changes from Revision A (November, 2007) to Revision B	Page
--	------

- | | |
|--|---|
| • Corrected package marking information shown in <i>Ordering Information</i> table | 2 |
|--|---|

PACKAGING INFORMATION

Orderable Device	Status (1)	Package Type	Package Drawing	Pins	Package Qty	Eco Plan (2)	Lead/Ball Finish	MSL Peak Temp (3)	Op Temp (°C)	Top-Side Markings (4)	Samples
UAF42AP	ACTIVE	PDIP	N	14	25	Green (RoHS & no Sb/Br)	CU NIPDAU	N / A for Pkg Type		UAF42AP	Samples
UAF42AP-1	OBSOLETE	PDIP	N	14		TBD	Call TI	Call TI			
UAF42APG4	ACTIVE	PDIP	N	14	25	Green (RoHS & no Sb/Br)	CU NIPDAU	N / A for Pkg Type		UAF42AP	Samples
UAF42AU	ACTIVE	SOIC	DW	16	40	Green (RoHS & no Sb/Br)	CU NIPDAU	Level-3-260C-168 HR	-25 to 85	UAF42AU	Samples
UAF42AU-1	OBSOLETE	SOIC	DW	16		TBD	Call TI	Call TI			
UAF42AUE4	ACTIVE	SOIC	DW	16	40	Green (RoHS & no Sb/Br)	CU NIPDAU	Level-3-260C-168 HR	-25 to 85	UAF42AU	Samples

(1) The marketing status values are defined as follows:

ACTIVE: Product device recommended for new designs.

LIFEBUY: TI has announced that the device will be discontinued, and a lifetime-buy period is in effect.

NRND: Not recommended for new designs. Device is in production to support existing customers, but TI does not recommend using this part in a new design.

PREVIEW: Device has been announced but is not in production. Samples may or may not be available.

OBSOLETE: TI has discontinued the production of the device.

(2) Eco Plan - The planned eco-friendly classification: Pb-Free (RoHS), Pb-Free (RoHS Exempt), or Green (RoHS & no Sb/Br) - please check <http://www.ti.com/productcontent> for the latest availability information and additional product content details.

TBD: The Pb-Free/Green conversion plan has not been defined.

Pb-Free (RoHS): TI's terms "Lead-Free" or "Pb-Free" mean semiconductor products that are compatible with the current RoHS requirements for all 6 substances, including the requirement that lead not exceed 0.1% by weight in homogeneous materials. Where designed to be soldered at high temperatures, TI Pb-Free products are suitable for use in specified lead-free processes.

Pb-Free (RoHS Exempt): This component has a RoHS exemption for either 1) lead-based flip-chip solder bumps used between the die and package, or 2) lead-based die adhesive used between the die and leadframe. The component is otherwise considered Pb-Free (RoHS compatible) as defined above.

Green (RoHS & no Sb/Br): TI defines "Green" to mean Pb-Free (RoHS compatible), and free of Bromine (Br) and Antimony (Sb) based flame retardants (Br or Sb do not exceed 0.1% by weight in homogeneous material)

(3) MSL, Peak Temp. -- The Moisture Sensitivity Level rating according to the JEDEC industry standard classifications, and peak solder temperature.

(4) Multiple Top-Side Markings will be inside parentheses. Only one Top-Side Marking contained in parentheses and separated by a "~" will appear on a device. If a line is indented then it is a continuation of the previous line and the two combined represent the entire Top-Side Marking for that device.

Important Information and Disclaimer: The information provided on this page represents TI's knowledge and belief as of the date that it is provided. TI bases its knowledge and belief on information provided by third parties, and makes no representation or warranty as to the accuracy of such information. Efforts are underway to better integrate information from third parties. TI has taken and

continues to take reasonable steps to provide representative and accurate information but may not have conducted destructive testing or chemical analysis on incoming materials and chemicals. TI and TI suppliers consider certain information to be proprietary, and thus CAS numbers and other limited information may not be available for release.

In no event shall TI's liability arising out of such information exceed the total purchase price of the TI part(s) at issue in this document sold by TI to Customer on an annual basis.

N (R-PDIP-T**)

PLASTIC DUAL-IN-LINE PACKAGE

16 PINS SHOWN



- NOTES:
- A. All linear dimensions are in inches (millimeters).
 - B. This drawing is subject to change without notice.
 - Falls within JEDEC MS-001, except 18 and 20 pin minimum body length (Dim A).
 - The 20 pin end lead shoulder width is a vendor option, either half or full width.

DW (R-PDSO-G16)

PLASTIC SMALL OUTLINE

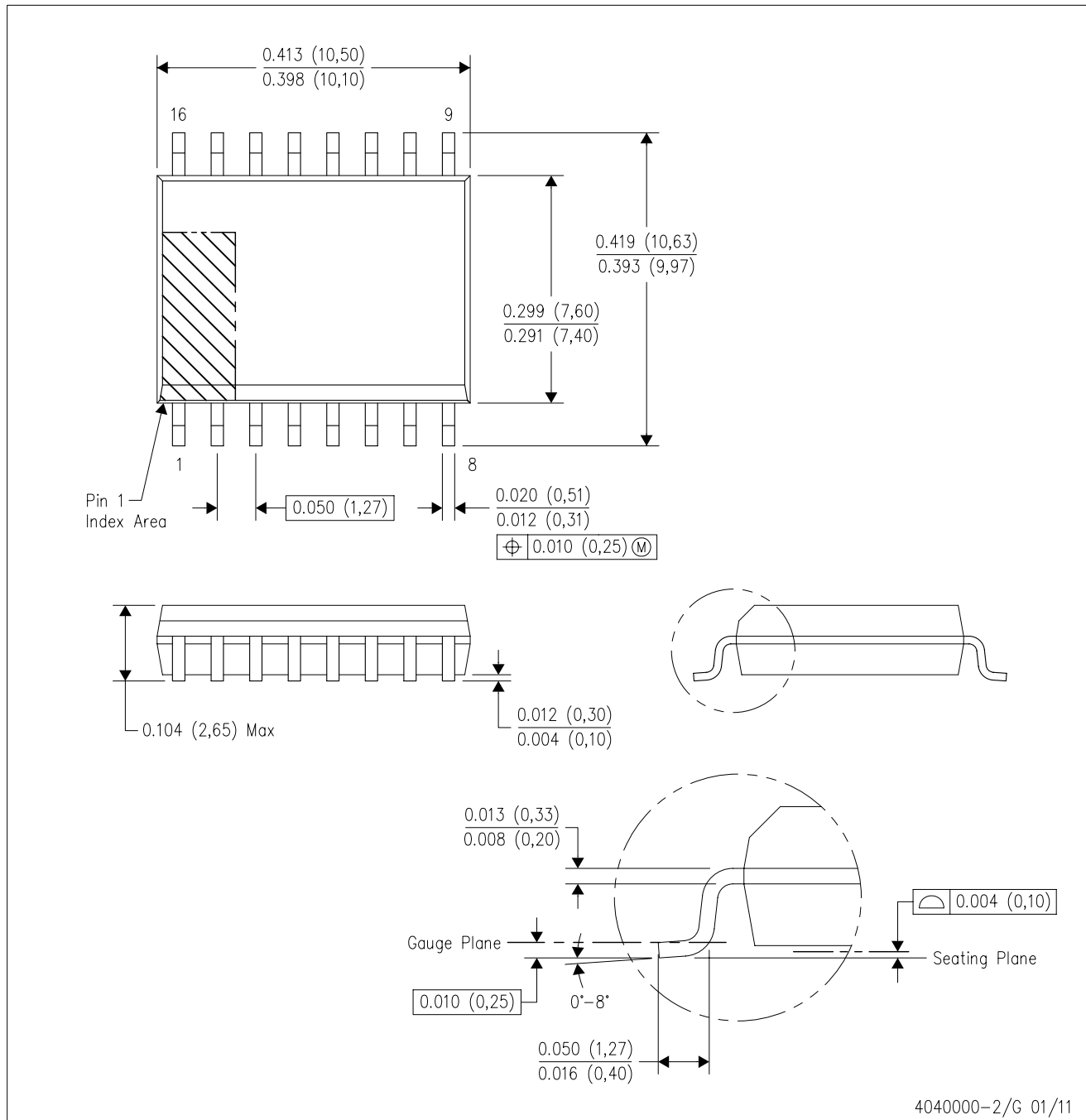

- NOTES:
- A. All linear dimensions are in inches (millimeters). Dimensioning and tolerancing per ASME Y14.5M-1994.
 - B. This drawing is subject to change without notice.
 - C. Body dimensions do not include mold flash or protrusion not to exceed 0.006 (0,15).
 - D. Falls within JEDEC MS-013 variation AA.

DW (R-PDSO-G16)

PLASTIC SMALL OUTLINE

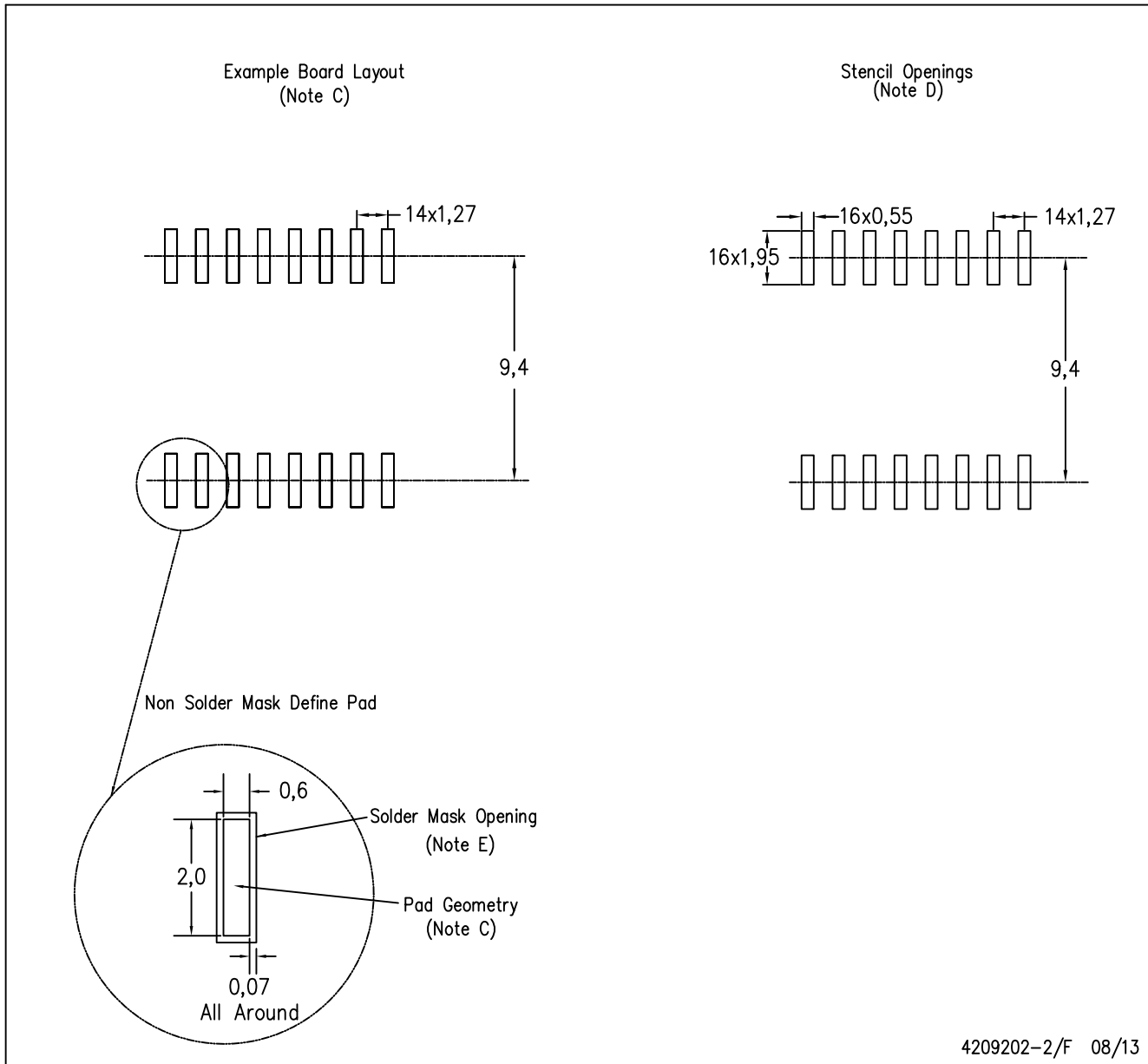

4209202-2/F 08/13

- NOTES:
- A. All linear dimensions are in millimeters.
 - B. This drawing is subject to change without notice.
 - C. Refer to IPC7351 for alternate board design.
 - D. Laser cutting apertures with trapezoidal walls and also rounding corners will offer better paste release. Customers should contact their board assembly site for stencil design recommendations. Refer to IPC-7525
 - E. Customers should contact their board fabrication site for solder mask tolerances between and around signal pads.

IMPORTANT NOTICE

Texas Instruments Incorporated and its subsidiaries (TI) reserve the right to make corrections, enhancements, improvements and other changes to its semiconductor products and services per JESD46, latest issue, and to discontinue any product or service per JESD48, latest issue. Buyers should obtain the latest relevant information before placing orders and should verify that such information is current and complete. All semiconductor products (also referred to herein as "components") are sold subject to TI's terms and conditions of sale supplied at the time of order acknowledgment.

TI warrants performance of its components to the specifications applicable at the time of sale, in accordance with the warranty in TI's terms and conditions of sale of semiconductor products. Testing and other quality control techniques are used to the extent TI deems necessary to support this warranty. Except where mandated by applicable law, testing of all parameters of each component is not necessarily performed.

TI assumes no liability for applications assistance or the design of Buyers' products. Buyers are responsible for their products and applications using TI components. To minimize the risks associated with Buyers' products and applications, Buyers should provide adequate design and operating safeguards.

TI does not warrant or represent that any license, either express or implied, is granted under any patent right, copyright, mask work right, or other intellectual property right relating to any combination, machine, or process in which TI components or services are used. Information published by TI regarding third-party products or services does not constitute a license to use such products or services or a warranty or endorsement thereof. Use of such information may require a license from a third party under the patents or other intellectual property of the third party, or a license from TI under the patents or other intellectual property of TI.

Reproduction of significant portions of TI information in TI data books or data sheets is permissible only if reproduction is without alteration and is accompanied by all associated warranties, conditions, limitations, and notices. TI is not responsible or liable for such altered documentation. Information of third parties may be subject to additional restrictions.

Resale of TI components or services with statements different from or beyond the parameters stated by TI for that component or service voids all express and any implied warranties for the associated TI component or service and is an unfair and deceptive business practice. TI is not responsible or liable for any such statements.

Buyer acknowledges and agrees that it is solely responsible for compliance with all legal, regulatory and safety-related requirements concerning its products, and any use of TI components in its applications, notwithstanding any applications-related information or support that may be provided by TI. Buyer represents and agrees that it has all the necessary expertise to create and implement safeguards which anticipate dangerous consequences of failures, monitor failures and their consequences, lessen the likelihood of failures that might cause harm and take appropriate remedial actions. Buyer will fully indemnify TI and its representatives against any damages arising out of the use of any TI components in safety-critical applications.

In some cases, TI components may be promoted specifically to facilitate safety-related applications. With such components, TI's goal is to help enable customers to design and create their own end-product solutions that meet applicable functional safety standards and requirements. Nonetheless, such components are subject to these terms.

No TI components are authorized for use in FDA Class III (or similar life-critical medical equipment) unless authorized officers of the parties have executed a special agreement specifically governing such use.

Only those TI components which TI has specifically designated as military grade or "enhanced plastic" are designed and intended for use in military/aerospace applications or environments. Buyer acknowledges and agrees that any military or aerospace use of TI components which have **not** been so designated is solely at the Buyer's risk, and that Buyer is solely responsible for compliance with all legal and regulatory requirements in connection with such use.

TI has specifically designated certain components as meeting ISO/TS16949 requirements, mainly for automotive use. In any case of use of non-designated products, TI will not be responsible for any failure to meet ISO/TS16949.

Products

Audio	www.ti.com/audio
Amplifiers	amplifier.ti.com
Data Converters	dataconverter.ti.com
DLP® Products	www.dlp.com
DSP	dsp.ti.com
Clocks and Timers	www.ti.com/clocks
Interface	interface.ti.com
Logic	logic.ti.com
Power Mgmt	power.ti.com
Microcontrollers	microcontroller.ti.com
RFID	www.ti-rfid.com
OMAP Applications Processors	www.ti.com/omap
Wireless Connectivity	www.ti.com/wirelessconnectivity

Applications

Automotive and Transportation	www.ti.com/automotive
Communications and Telecom	www.ti.com/communications
Computers and Peripherals	www.ti.com/computers
Consumer Electronics	www.ti.com/consumer-apps
Energy and Lighting	www.ti.com/energy
Industrial	www.ti.com/industrial
Medical	www.ti.com/medical
Security	www.ti.com/security
Space, Avionics and Defense	www.ti.com/space-avionics-defense
Video and Imaging	www.ti.com/video

TI E2E Community

e2e.ti.com

Looking for pricing, stock, or lifecycle information?

Click below to explore more details on WIN SOURCE:

 [View UAF42AUE4](#) on WIN SOURCE

 [Texas Instruments](#) Information

Optimize Your Supply Chain with WIN SOURCE Solutions

-  Global Sourcing Solution
-  Obsolete Management
-  Cost Control Management
-  Shortage Management
-  Alternative Solution
-  Excess Inventory Management