



THE DATASHEET OF UA741CP



μA741 General-Purpose Operational Amplifiers

1 Features

- Short-Circuit Protection
- Offset-Voltage Null Capability
- Large Common-Mode and Differential Voltage Ranges
- No Frequency Compensation Required
- No Latch-Up

2 Applications

- DVD Recorders and Players
- Pro Audio Mixers

3 Description

The μA741 device is a general-purpose operational amplifier featuring offset-voltage null capability.

The high common-mode input voltage range and the absence of latch-up make the amplifier ideal for voltage-follower applications. The device is short-circuit protected and the internal frequency compensation ensures stability without external components. A low-value potentiometer may be connected between the offset null inputs to null out the offset voltage as shown in [Figure 12](#).

The μA741C device is characterized for operation from 0°C to 70°C.

Device Information⁽¹⁾

PART NUMBER	PACKAGE	BODY SIZE (NOM)
μA741CD	SOIC (8)	4.90 mm × 3.91 mm
μA741CP	PDIP (8)	9.81 mm × 6.35 mm
μA741CPS	SO (8)	6.20 mm × 5.30 mm

(1) For all available packages, see the orderable addendum at the end of the data sheet.

Simplified Schematic

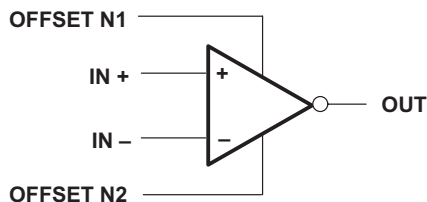

Table of Contents

1 Features	1	7.3 Feature Description	10
2 Applications	1	7.4 Device Functional Modes	11
3 Description	1	7.5 μ A741Y Chip Information	11
4 Revision History	2	8 Application and Implementation	12
5 Pin Configurations and Functions	4	8.1 Application Information	12
6 Specifications	5	8.2 Typical Application	12
6.1 Absolute Maximum Ratings	5	9 Power Supply Recommendations	14
6.2 Recommended Operating Conditions	5	10 Layout	14
6.3 Thermal Information	5	10.1 Layout Guidelines	14
6.4 Electrical Characteristics: μ A741C	6	10.2 Layout Example	14
6.5 Electrical Characteristics: μ A741Y	7	11 Device and Documentation Support	16
6.6 Switching Characteristics: μ A741C	7	11.1 Receiving Notification of Documentation Updates	16
6.7 Switching Characteristics: μ A741Y	7	11.2 Trademarks	16
6.8 Typical Characteristics	8	11.3 Electrostatic Discharge Caution	16
7 Detailed Description	10	11.4 Glossary	16
7.1 Overview	10	12 Mechanical, Packaging, and Orderable Information	16
7.2 Functional Block Diagram	10		

4 Revision History

Changes from Revision F (May 2017) to Revision G Page

• Changed supply voltage unit from "°C" to "V" in <i>Absolute Maximum Ratings</i> table	5
---	----------

Changes from Revision E (January 2015) to Revision F Page

• Updated data sheet text to the latest documentation and translation standards	1
• Deleted text regarding μ A741M device (obsolete package) from <i>Description</i> section	1
• Added μ A741CD, μ A741CP, and μ A741CPS devices to <i>Device Information</i> table	1
• Deleted μ A741x device from <i>Device Information</i> table	1
• Updated pinout diagrams and <i>Pin Functions</i> tables in the <i>Pin Configurations and Functions</i> section	4
• Deleted μ A741M pinout drawings information from <i>Pin Configurations and Functions</i> section	4
• Deleted Electrical Characteristics: μ A741M table from <i>Specifications</i> section	5
• Added operating junction temperature (T_J) and values to <i>Absolute Maximum Ratings</i> table	5
• Deleted text regarding μ A741M from <i>Absolute Maximum Ratings</i> table	5
• Deleted text regarding μ A741M device from <i>Recommended Operating Conditions</i> table	5
• Deleted <i>Dissipation Ratings</i> table	5
• Added <i>Thermal Information</i> table and values	5
• Deleted μ A741M in <i>Switching Characteristics</i> table	7
• Correct typo in Figure 1	8
• Deleted text regarding μ A741M device from <i>Detailed Description</i> section	10
• Updated text in <i>Overview</i> section	10
• Added 2017 copyright to <i>Functional Block Diagram</i>	10
• Added caption to Figure 11 in <i>Device Functional Modes</i> section	11
• Changed pins 1 and 5 from "NC" to "Offset N1" and "Offset N2" in Figure 18	15

Changes from Revision D (February 2014) to Revision E **Page**

- Added *Applications*, *Device Information* table, *Pin Functions* table, *ESD Ratings* table, *Thermal Information* table, *Feature Description* section, *Device Functional Modes*, *Application and Implementation* section, *Power Supply Recommendations* section, *Layout* section, *Device and Documentation Support* section, and *Mechanical, Packaging, and Orderable Information* section. 1
 - Moved *Typical Characteristics* into *Specifications* section. 8
-

Changes from Revision C (January 2014) to Revision D **Page**

- Fixed *Typical Characteristics* graphs to remove extra lines. 8
-

Changes from Revision B (September 2000) to Revision C **Page**

- Updated document to new TI data sheet format - no specification changes. 1
 - Deleted *Ordering Information* table. 1
-

5 Pin Configurations and Functions

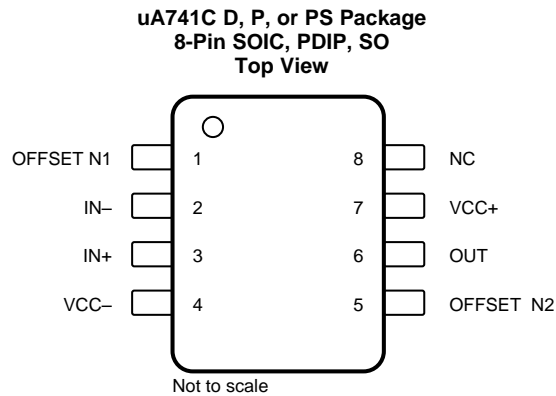

NC- no internal connection

Pin Functions

PIN		I/O	DESCRIPTION
NAME	NO.		
IN+	3	I	Noninverting input
IN-	2	I	Inverting input
NC	8	—	No internal connection
OFFSET N1	1	I	External input offset voltage adjustment
OFFSET N2	5	I	External input offset voltage adjustment
OUT	6	O	Output
VCC+	7	—	Positive supply
VCC-	4	—	Negative supply

6 Specifications

6.1 Absolute Maximum Ratings

over virtual junction temperature range (unless otherwise noted)⁽¹⁾

		MIN	MAX	UNIT
Supply voltage, V_{CC} ⁽²⁾	μ A741C	-18	18	V
Differential input voltage, V_{ID} ⁽³⁾	μ A741C	-15	15	V
Input voltage, V_I (any input) ⁽²⁾⁽⁴⁾	μ A741C	-15	15	V
Voltage between offset null (either OFFSET N1 or OFFSET N2) and V_{CC-}	μ A741C	-15	15	V
Duration of output short circuit ⁽⁵⁾		Unlimited		
Continuous total power dissipation		See Thermal Information		
Case temperature for 60 seconds	μ A741C	N/A	N/A	°C
Lead temperature 1.6 mm (1/16 inch) from case for 60 seconds	μ A741C	N/A	N/A	°C
Lead temperature 1.6 mm (1/16 inch) from case for 10 seconds	D, P, or PS package μ A741C		260	°C
Operating junction temperature, T_J			150	°C
Storage temperature range, T_{stg}	μ A741C	-65	150	°C

- (1) Stresses beyond those listed under *Absolute Maximum Ratings* may cause permanent damage to the device. These are stress ratings only, and functional operation of the device at these or any other conditions beyond those indicated under *Recommended Operating Conditions* is not implied. Exposure to absolute-maximum-rated conditions for extended periods may affect device reliability.
- (2) All voltage values, unless otherwise noted, are with respect to the midpoint between V_{CC+} and V_{CC-} .
- (3) Differential voltages are at IN+ with respect to IN-.
- (4) The magnitude of the input voltage must never exceed the magnitude of the supply voltage or 15 V, whichever is less.
- (5) The output may be shorted to ground or either power supply.

6.2 Recommended Operating Conditions

		MIN	MAX	UNIT
V_{CC+} — Supply voltage		5	15	V
V_{CC-}		-5	-15	V
T_A — Operating free-air temperature	μ A741C	0	70	°C

6.3 Thermal Information

THERMAL METRIC ⁽¹⁾	μ A741			UNIT
	D (SOIC)	P (PDIP)	PS (SO)	
	8 PINS	8 PINS	8 PINS	
$R_{\theta JA}$ — Junction-to-ambient thermal resistance	129.2	87.4	119.7	°C/W
$R_{\theta JC(top)}$ — Junction-to-case (top) thermal resistance	73.6	89.3	66	°C/W
$R_{\theta JB}$ — Junction-to-board thermal resistance	72.4	64.4	70	°C/W
Ψ_{JT} — Junction-to-top characterization parameter	25.9	49.8	27.2	°C/W
Ψ_{JB} — Junction-to-board characterization parameter	71.7	64.1	69	°C/W

- (1) For more information about traditional and new thermal metrics, see the [Semiconductor and IC Package Thermal Metrics](#) application report.

6.4 Electrical Characteristics: μ A741C

 at specified virtual junction temperature, $V_{CC\pm} = \pm 15$ V (unless otherwise noted)

PARAMETER		TEST CONDITIONS ⁽¹⁾		MIN	TYP	MAX	UNIT
V_{IO}	Input offset voltage	$V_O = 0$	25°C		1	6	mV
			Full range			7.5	
$\Delta V_{IO(adj)}$	Offset voltage adjust range	$V_O = 0$	25°C		± 15		mV
I_{IO}	Input offset current	$V_O = 0$	25°C		20	200	nA
			Full range			300	
I_{IB}	Input bias current	$V_O = 0$	25°C		80	500	nA
			Full range			800	
V_{ICR}	Common-mode input voltage range	25°C		± 12	± 13		V
		Full range		± 12			
V_{OM}	Maximum peak output voltage swing	$R_L = 10$ k Ω	25°C	± 12	± 14		V
		$R_L \geq 10$ k Ω	Full range	± 12			
		$R_L = 2$ k Ω	25°C	± 10			
		$R_L \geq 2$ k Ω	Full range	± 10			
A_{VD}	Large-signal differential voltage amplification	$R_L \geq 2$ k Ω	25°C	20	200		V/mV
		$V_O = \pm 10$ V	Full range	15			
r_i	Input resistance	25°C		0.3	2		M Ω
r_o	Output resistance	$V_O = 0$; see ⁽²⁾	25°C		75		Ω
C_i	Input capacitance	25°C			1.4		pF
CMRR	Common-mode rejection ratio	$V_{IC} = V_{ICRmin}$	25°C		70	90	dB
			Full range		70		
k_{SVS}	Supply voltage sensitivity ($\Delta V_{IO}/\Delta V_{CC}$)	$V_{CC} = \pm 9$ V to ± 15 V	25°C		30	150	μ V/V
			Full range			150	
I_{OS}	Short-circuit output current	25°C			± 25	± 40	mA
I_{CC}	Supply current	$V_O = 0$; no load	25°C		1.7	2.8	mA
			Full range			3.3	
P_D	Total power dissipation	$V_O = 0$; no load	25°C		50	85	mW
			Full range			100	

(1) All characteristics are measured under open-loop conditions with zero common-mode input voltage unless otherwise specified. Full range for the μ A741C is 0°C to 70°C.

(2) This typical value applies only at frequencies above a few hundred hertz because of the effects of drift and thermal feedback.

6.5 Electrical Characteristics: μ A741Y

at specified virtual junction temperature, $V_{CC\pm} = \pm 15$ V, $T_A = 25^\circ\text{C}$ (unless otherwise noted)⁽¹⁾

PARAMETER		TEST CONDITIONS ⁽²⁾	MIN	TYP	MAX	UNIT
V_{IO}	Input offset voltage	$V_O = 0$		1	5	mV
$\Delta V_{IO(\text{adj})}$	Offset voltage adjust range	$V_O = 0$		± 15		mV
I_{IO}	Input offset current	$V_O = 0$		20	200	nA
I_{IB}	Input bias current	$V_O = 0$		80	500	nA
V_{ICR}	Common-mode input voltage range		± 12	± 13		V
V_{OM}	Maximum peak output voltage swing	$R_L = 10$ k Ω	± 12	± 14		V
		$R_L = 2$ k Ω	± 10	± 13		
A_{VD}	Large-signal differential voltage amplification	$R_L \geq 2$ k Ω	20	200		V/mV
r_i	Input resistance		0.3	2		M Ω
r_o	Output resistance	$V_O = 0$; see ⁽¹⁾		75		Ω
C_i	Input capacitance			1.4		pF
CMRR	Common-mode rejection ratio	$V_{IC} = V_{ICR\text{min}}$	70	90		dB
k_{SVS}	Supply voltage sensitivity ($\Delta V_{IO}/\Delta V_{CC}$)	$V_{CC} = \pm 9$ V to ± 15 V		30	150	$\mu\text{V/V}$
I_{OS}	Short-circuit output current			± 25	± 40	mA
I_{CC}	Supply current	$V_O = 0$; no load		1.7	2.8	mA
P_D	Total power dissipation	$V_O = 0$; no load		50	85	mW

(1) This typical value applies only at frequencies above a few hundred hertz because of the effects of drift and thermal feedback.

(2) All characteristics are measured under open-loop conditions with zero common-mode voltage unless otherwise specified.

6.6 Switching Characteristics: μ A741C

over operating free-air temperature range, $V_{CC\pm} = \pm 15$ V, $T_A = 25^\circ\text{C}$ (unless otherwise noted)

PARAMETER		TEST CONDITIONS	MIN	TYP	MAX	UNIT
t_r	Rise time	$V_I = 20$ mV, $R_L = 2$ k Ω		0.3		μs
	Overshoot factor	$C_L = 100$ pF; see Figure 1		5%		
SR	Slew rate at unity gain	$V_I = 10$ V, $R_L = 2$ k Ω $C_L = 100$ pF; see Figure 1		0.5		V/ μs

6.7 Switching Characteristics: μ A741Y

over operating free-air temperature range, $V_{CC\pm} = \pm 15$ V, $T_A = 25^\circ\text{C}$ (unless otherwise noted)

PARAMETER		TEST CONDITIONS	MIN	TYP	MAX	UNIT
t_r	Rise time	$V_I = 20$ mV, $R_L = 2$ k Ω		0.3		μs
	Overshoot factor	$C_L = 100$ pF; see Figure 1		5%		
SR	Slew rate at unity gain	$V_I = 10$ V, $R_L = 2$ k Ω $C_L = 100$ pF; see Figure 1		0.5		V/ μs

6.8 Typical Characteristics

Data at high and low temperatures are applicable only within the rated operating free-air temperature ranges of the various devices.

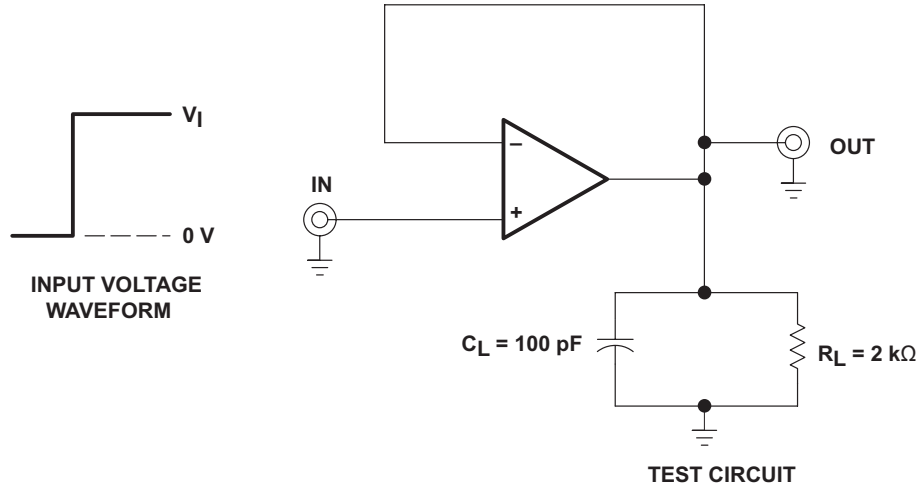

Figure 1. Rise Time, Overshoot, and Slew Rate

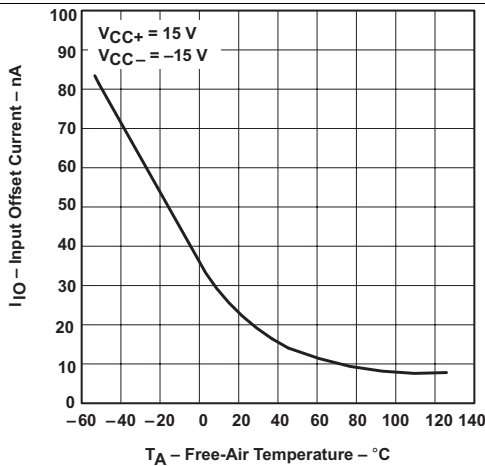

Figure 2. Input Offset Current vs Free-Air Temperature

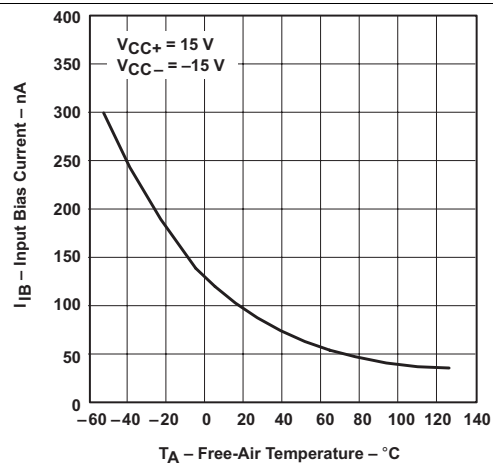

Figure 3. Input Bias Current vs Free-Air Temperature

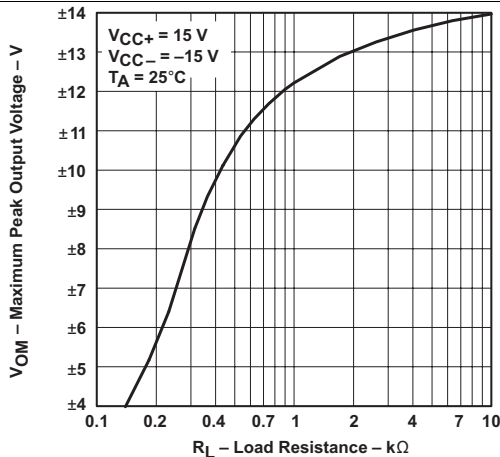

Figure 4. Maximum Output Voltage vs Load Resistance

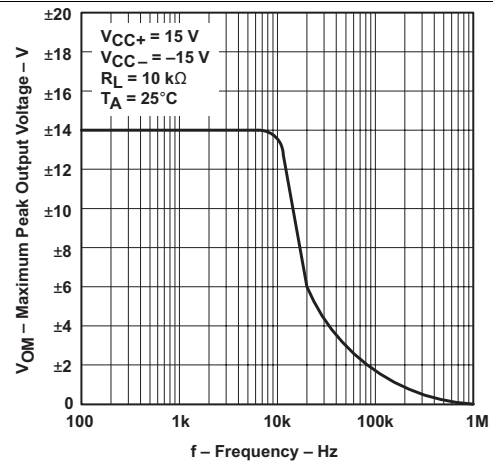

Figure 5. Maximum Peak Output Voltage vs Frequency

Typical Characteristics (continued)

Data at high and low temperatures are applicable only within the rated operating free-air temperature ranges of the various devices.

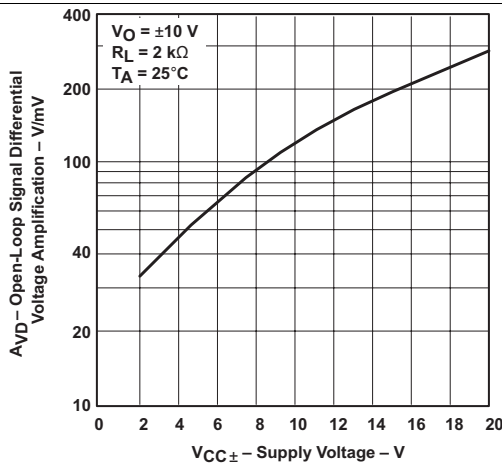

Figure 6. Open-Loop Signal Differential Voltage Amplification vs Supply Voltage

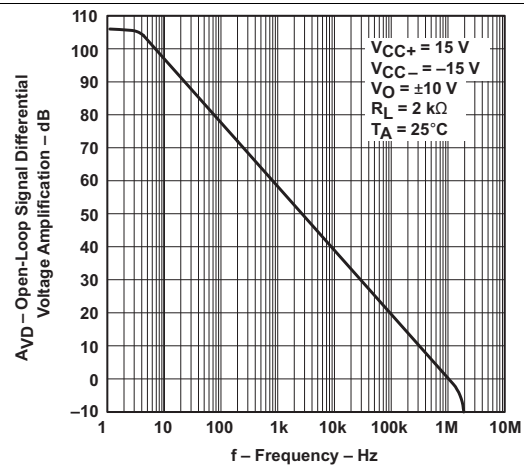

Figure 7. Open-Loop Large-Signal Differential Voltage Amplification vs Frequency

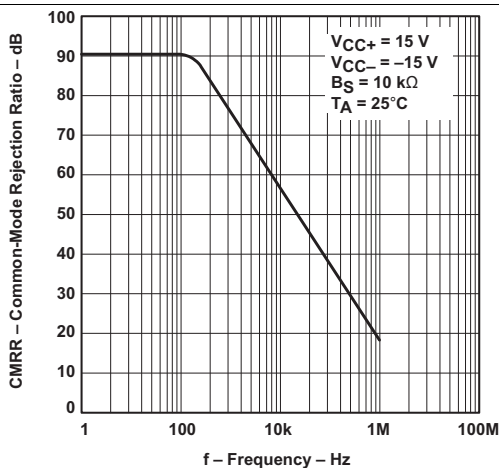

Figure 8. Common-Mode Rejection Ratio vs Frequency

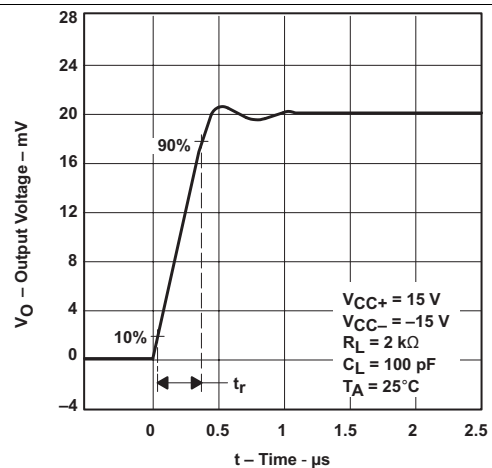

Figure 9. Output Voltage vs Elapsed Time

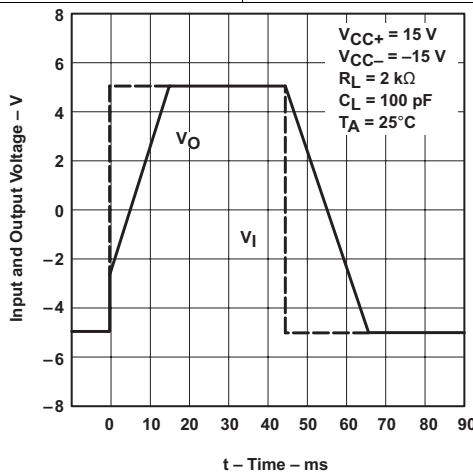

Figure 10. Voltage-Follower Large-Signal Pulse Response

7 Detailed Description

7.1 Overview

The μ A741 has been a popular operational amplifier for over four decades. Typical open loop gain is 106 dB while driving a 2000- Ω load. Short circuit tolerance, offset voltage trimming, and unity-gain stability makes the μ A741 useful for many applications.

7.2 Functional Block Diagram

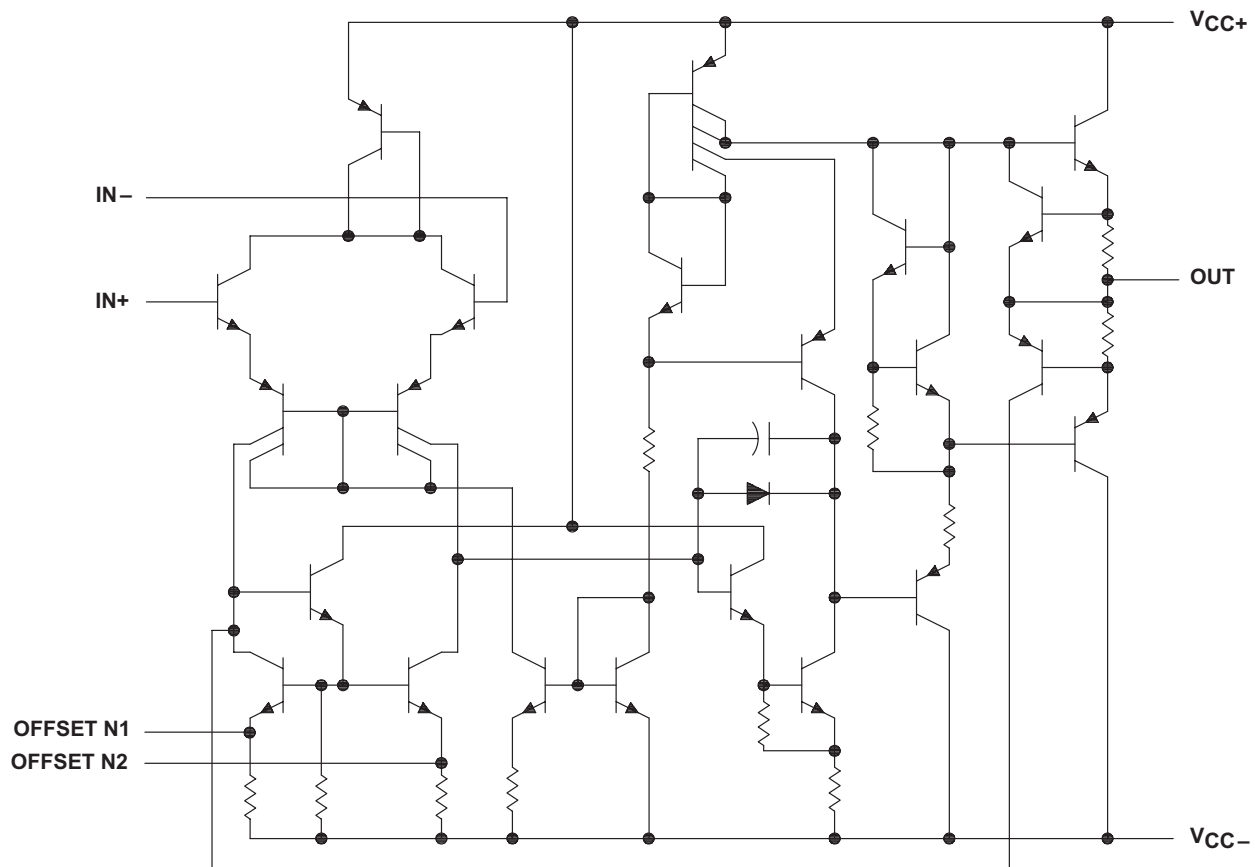

Component Count	
Transistors	22
Resistors	11
Diode	1
Capacitor	1

Copyright © 2017, Texas Instruments Incorporated

7.3 Feature Description

7.3.1 Offset-Voltage Null Capability

The input offset voltage of operational amplifiers (op amps) arises from unavoidable mismatches in the differential input stage of the op-amp circuit caused by mismatched transistor pairs, collector currents, current-gain betas (β), collector or emitter resistors and so forth. The input offset pins allow the designer to adjust for mismatches caused by external circuitry. See [Application and Implementation](#) for more details on design techniques.

8 Application and Implementation

NOTE

Information in the following applications sections is not part of the TI component specification, and TI does not warrant its accuracy or completeness. TI's customers are responsible for determining suitability of components for their purposes. Customers should validate and test their design implementation to confirm system functionality.

8.1 Application Information

The input offset voltage of operational amplifiers (op amps) arises from unavoidable mismatches in the differential input stage of the op-amp circuit caused by mismatched transistor pairs, collector currents, current-gain betas (β), collector or emitter resistors and so forth. The input offset pins allow the designer to adjust for mismatches resulting from external circuitry. These input mismatches can be adjusted by placing resistors or a potentiometer between the inputs as shown in [Figure 12](#). A potentiometer can fine-tune the circuit during testing or for applications which require precision offset control. For more information about designing using the input-offset pins, see [Nulling Input Offset Voltage of Operational Amplifiers](#).

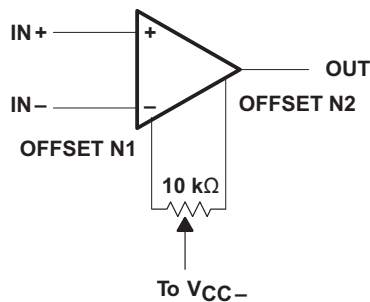

Figure 12. Input Offset Voltage Null Circuit

8.2 Typical Application

The voltage follower configuration of the operational amplifier is used for applications where a weak signal drives a relatively high current load. This circuit is also called a buffer amplifier or unity-gain amplifier. The inputs of an operational amplifier have a very high resistance which puts a negligible current load on the voltage source. The output resistance of the operational amplifier is almost negligible, so the resistance can provide as much current as necessary to the output load.

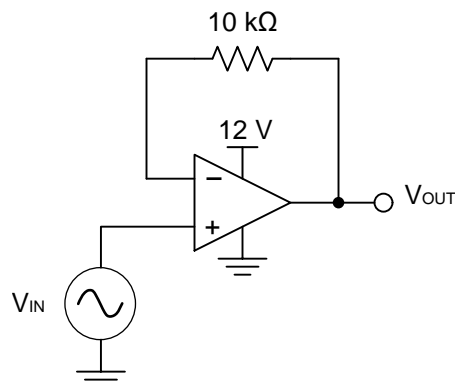

Figure 13. Voltage Follower Schematic

Typical Application (continued)

8.2.1 Design Requirements

- Output range from 2 V to 11.5 V
- Input range from 2 V to 11.5 V
- Resistive feedback to negative input

8.2.2 Detailed Design Procedure

8.2.2.1 Output Voltage Swing

The output voltage of an operational amplifier is limited by the internal circuitry to some level below the supply rails. For this amplifier, the output voltage swing is within ± 12 V, which accommodates the input and output voltage requirements.

8.2.2.2 Supply and Input Voltage

For correct operation of the amplifier, neither input must be higher than the recommended positive supply rail voltage or lower than the recommended negative supply rail voltage. The selected amplifier must be able to operate at the supply voltage that accommodates the inputs. Because the input for this application goes up to 11.5 V, the supply voltage must be 12 V. Using a negative voltage on the lower rail rather than ground allows the amplifier to maintain linearity for inputs below 2 V.

8.2.3 Application Curves for Output Characteristics

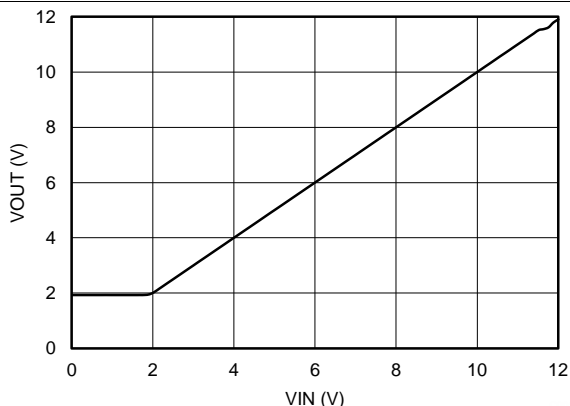

Figure 14. Output Voltage vs Input Voltage

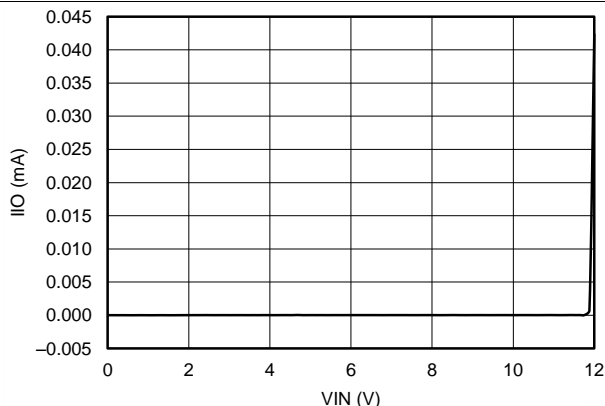

Figure 15. Current Drawn Input of Voltage Follower (I_{IO}) vs Input Voltage

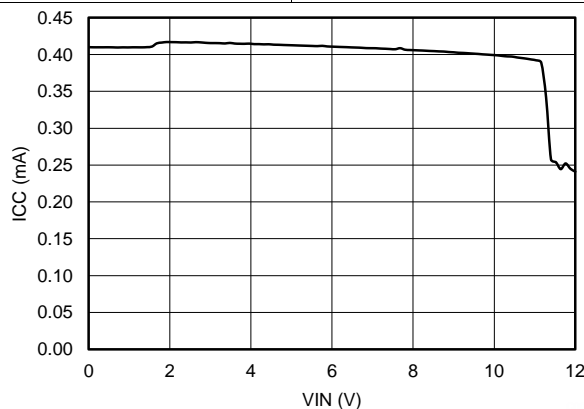

Figure 16. Current Drawn from Supply (I_{CC}) vs Input Voltage

9 Power Supply Recommendations

The μ A741 device is specified for operation from ± 5 to ± 15 V; many specifications apply from 0°C to 70°C . [Typical Characteristics](#) presents parameters that can exhibit significant variance with regard to operating voltage or temperature.

Place 0.1- μF bypass capacitors close to the power-supply pins to reduce errors coupling in from noisy or high impedance power supplies. For more detailed information on bypass capacitor placement, see [Layout Guidelines](#).

CAUTION

Supply voltages larger than ± 18 V can permanently damage the device (see [Absolute Maximum Ratings](#)).

10 Layout

10.1 Layout Guidelines

For best operational performance of the device, use good PCB layout practices, including:

- Noise can propagate into analog circuitry through the power pins of the circuit as a whole and the operational amplifier. Bypass capacitors reduce the coupled noise by providing low impedance power sources local to the analog circuitry.
 - Connect low-ESR, 0.1- μF ceramic bypass capacitors between each supply pin and ground, placed as close as possible to the device. A single bypass capacitor from $V+$ to ground is applicable for single-supply applications.
- Separate grounding for analog and digital portions of circuitry is one of the simplest and most-effective methods of noise suppression. One or more layers on multilayer PCBs are usually devoted to ground planes. A ground plane helps distribute heat and reduces EMI noise pickup. Make sure to physically separate digital and analog grounds, paying attention to the flow of the ground current. For more detailed information, see [Circuit Board Layout Techniques](#).
- To reduce parasitic coupling, run the input traces as far away as possible from the supply or output traces. If it is not possible to keep them separate, it is much better to cross the sensitive trace perpendicular as opposed to in parallel with the noisy trace.
- Place the external components as close as possible to the device. Keeping R_F and R_G close to the inverting input minimizes parasitic capacitance, as shown in [Layout Example](#).
- Keep the length of input traces as short as possible. Always remember that the input traces are the most sensitive part of the circuit.
- Consider a driven, low-impedance guard ring around the critical traces. A guard ring can significantly reduce leakage currents from nearby traces that are at different potentials.

10.2 Layout Example

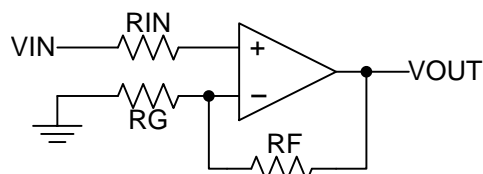

Figure 17. Operational Amplifier Schematic for Noninverting Configuration

Layout Example (continued)

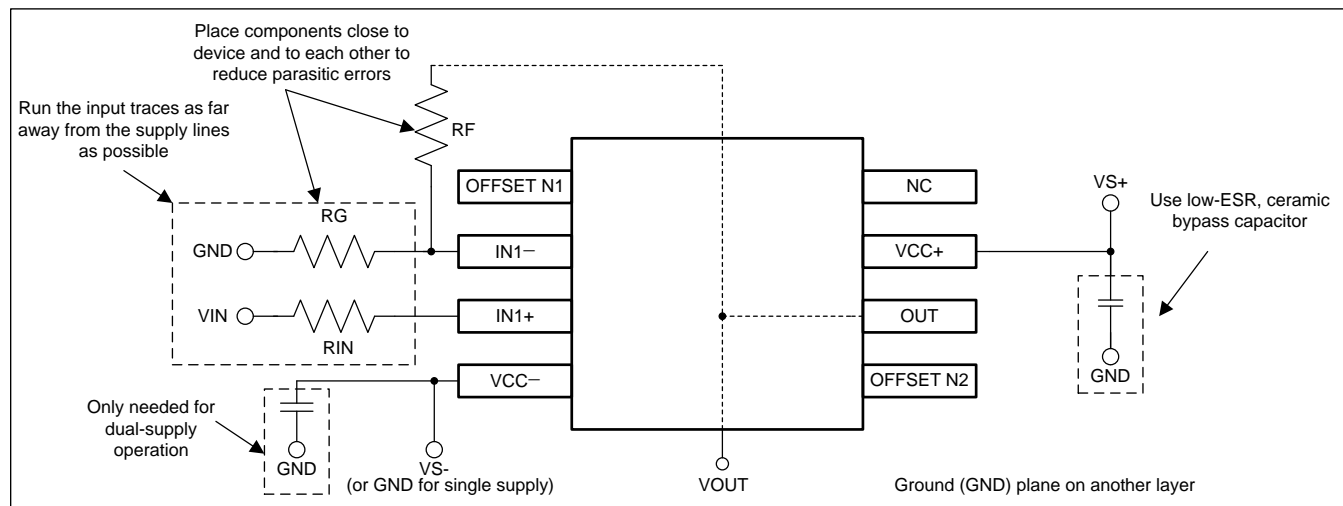

Figure 18. Operational Amplifier Board Layout for Noninverting Configuration

11 Device and Documentation Support

11.1 Receiving Notification of Documentation Updates

To receive notification of documentation updates, navigate to the device product folder on ti.com. In the upper right corner, click on *Alert me* to register and receive a weekly digest of any product information that has changed. For change details, review the revision history included in any revised document.

11.2 Trademarks

All trademarks are the property of their respective owners.

11.3 Electrostatic Discharge Caution



These devices have limited built-in ESD protection. The leads should be shorted together or the device placed in conductive foam during storage or handling to prevent electrostatic damage to the MOS gates.

11.4 Glossary

[SLYZ022](#) — *TI Glossary*.

This glossary lists and explains terms, acronyms, and definitions.

12 Mechanical, Packaging, and Orderable Information

The following pages include mechanical packaging and orderable information. This information is the most current data available for the designated devices. This data is subject to change without notice and revision of this document. For browser based versions of this data sheet, refer to the left hand navigation.

PACKAGING INFORMATION

Orderable Device	Status (1)	Package Type	Package Drawing	Pins	Package Qty	Eco Plan (2)	Lead finish/ Ball material (6)	MSL Peak Temp (3)	Op Temp (°C)	Device Marking (4/5)	Samples
UA741CDR	ACTIVE	SOIC	D	8	2500	RoHS & Green	NIPDAU	Level-1-260C-UNLIM	0 to 70	UA741C	Samples
UA741CP	ACTIVE	PDIP	P	8	50	RoHS & Green	NIPDAU	N / A for Pkg Type	0 to 70	UA741CP	Samples
UA741CPE4	ACTIVE	PDIP	P	8	50	TBD	Call TI	Call TI	0 to 70		Samples
UA741CPSR	ACTIVE	SO	PS	8	2000	RoHS & Green	NIPDAU	Level-1-260C-UNLIM	0 to 70	U741	Samples
UA741CPSRE4	ACTIVE	SO	PS	8	2000	RoHS & Green	NIPDAU	Level-1-260C-UNLIM	0 to 70	U741	Samples

(1) The marketing status values are defined as follows:

ACTIVE: Product device recommended for new designs.

LIFEBUY: TI has announced that the device will be discontinued, and a lifetime-buy period is in effect.

NRND: Not recommended for new designs. Device is in production to support existing customers, but TI does not recommend using this part in a new design.

PREVIEW: Device has been announced but is not in production. Samples may or may not be available.

OBSELETE: TI has discontinued the production of the device.

(2) **RoHS:** TI defines "RoHS" to mean semiconductor products that are compliant with the current EU RoHS requirements for all 10 RoHS substances, including the requirement that RoHS substance do not exceed 0.1% by weight in homogeneous materials. Where designed to be soldered at high temperatures, "RoHS" products are suitable for use in specified lead-free processes. TI may reference these types of products as "Pb-Free".

RoHS Exempt: TI defines "RoHS Exempt" to mean products that contain lead but are compliant with EU RoHS pursuant to a specific EU RoHS exemption.

Green: TI defines "Green" to mean the content of Chlorine (Cl) and Bromine (Br) based flame retardants meet JS709B low halogen requirements of <=1000ppm threshold. Antimony trioxide based flame retardants must also meet the <=1000ppm threshold requirement.

(3) MSL, Peak Temp. - The Moisture Sensitivity Level rating according to the JEDEC industry standard classifications, and peak solder temperature.

(4) There may be additional marking, which relates to the logo, the lot trace code information, or the environmental category on the device.

(5) Multiple Device Markings will be inside parentheses. Only one Device Marking contained in parentheses and separated by a "~" will appear on a device. If a line is indented then it is a continuation of the previous line and the two combined represent the entire Device Marking for that device.

(6) Lead finish/Ball material - Orderable Devices may have multiple material finish options. Finish options are separated by a vertical ruled line. Lead finish/Ball material values may wrap to two lines if the finish value exceeds the maximum column width.

Important Information and Disclaimer: The information provided on this page represents TI's knowledge and belief as of the date that it is provided. TI bases its knowledge and belief on information provided by third parties, and makes no representation or warranty as to the accuracy of such information. Efforts are underway to better integrate information from third parties. TI has taken and continues to take reasonable steps to provide representative and accurate information but may not have conducted destructive testing or chemical analysis on incoming materials and chemicals. TI and TI suppliers consider certain information to be proprietary, and thus CAS numbers and other limited information may not be available for release.

In no event shall TI's liability arising out of such information exceed the total purchase price of the TI part(s) at issue in this document sold by TI to Customer on an annual basis.

TAPE AND REEL INFORMATION



QUADRANT ASSIGNMENTS FOR PIN 1 ORIENTATION IN TAPE



*All dimensions are nominal

Device	Package Type	Package Drawing	Pins	SPQ	Reel Diameter (mm)	Reel Width W1 (mm)	A0 (mm)	B0 (mm)	K0 (mm)	P1 (mm)	W (mm)	Pin1 Quadrant
UA741CDR	SOIC	D	8	2500	330.0	12.4	6.4	5.2	2.1	8.0	12.0	Q1
UA741CPSR	SO	PS	8	2000	330.0	16.4	8.35	6.6	2.4	12.0	16.0	Q1

TAPE AND REEL BOX DIMENSIONS

*All dimensions are nominal

Device	Package Type	Package Drawing	Pins	SPQ	Length (mm)	Width (mm)	Height (mm)
UA741CDR	SOIC	D	8	2500	340.5	338.1	20.6
UA741CPSR	SO	PS	8	2000	356.0	356.0	35.0

TUBE

*All dimensions are nominal

Device	Package Name	Package Type	Pins	SPQ	L (mm)	W (mm)	T (μm)	B (mm)
UA741CP	P	PDIP	8	50	506	13.97	11230	4.32

EXAMPLE BOARD LAYOUT

D0008A

SOIC - 1.75 mm max height

SMALL OUTLINE INTEGRATED CIRCUIT



LAND PATTERN EXAMPLE
EXPOSED METAL SHOWN
SCALE:8X



SOLDER MASK DETAILS

4214825/C 02/2019

NOTES: (continued)

6. Publication IPC-7351 may have alternate designs.

7. Solder mask tolerances between and around signal pads can vary based on board fabrication site.

EXAMPLE STENCIL DESIGN

D0008A

SOIC - 1.75 mm max height

SMALL OUTLINE INTEGRATED CIRCUIT



SOLDER PASTE EXAMPLE
BASED ON .005 INCH [0.125 MM] THICK STENCIL
SCALE:8X

4214825/C 02/2019

NOTES: (continued)

8. Laser cutting apertures with trapezoidal walls and rounded corners may offer better paste release. IPC-7525 may have alternate design recommendations.
9. Board assembly site may have different recommendations for stencil design.

MECHANICAL DATA

PS (R-PDSO-G8)

PLASTIC SMALL-OUTLINE PACKAGE

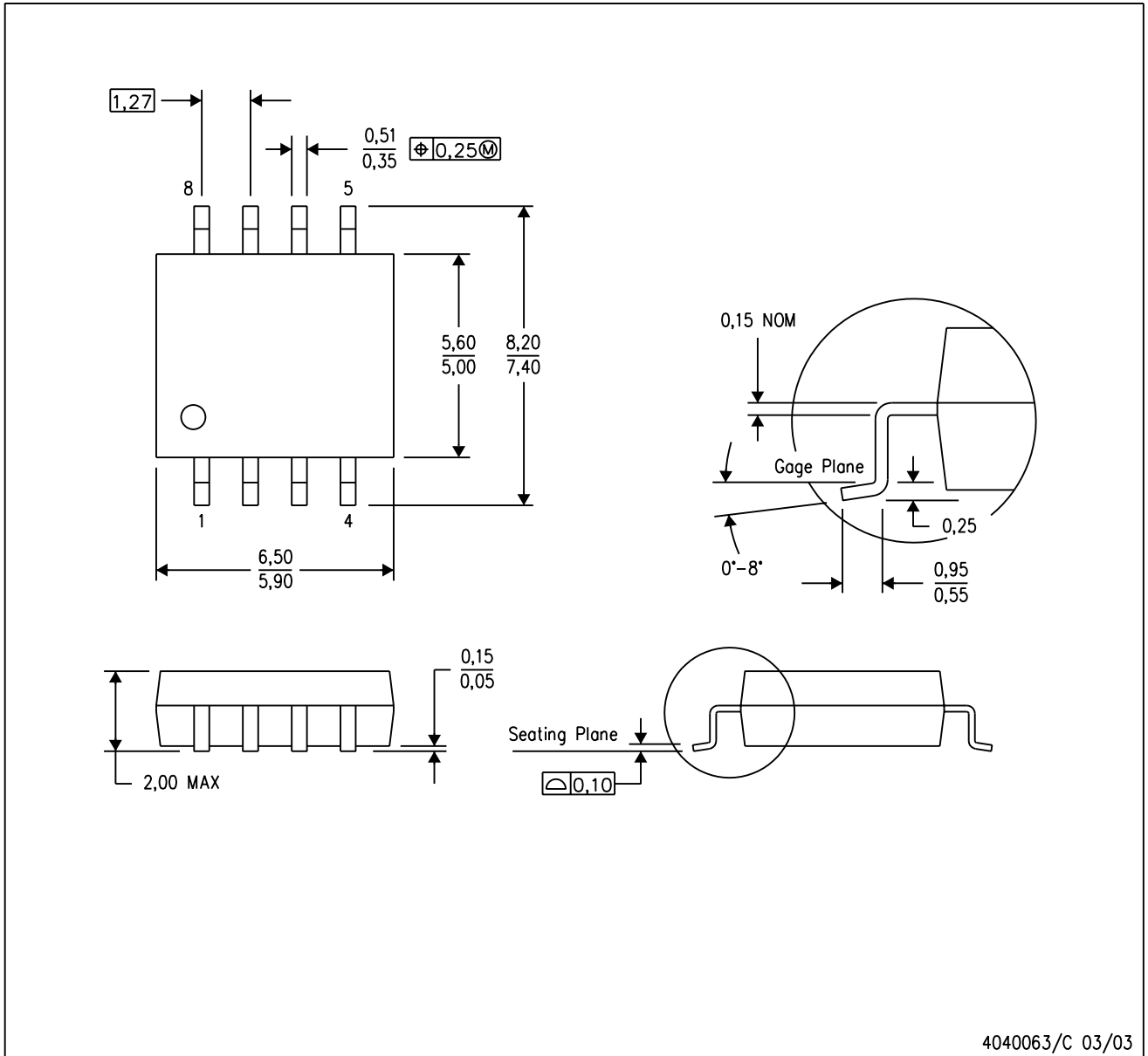

- NOTES:
- A. All linear dimensions are in millimeters.
 - B. This drawing is subject to change without notice.
 - C. Body dimensions do not include mold flash or protrusion, not to exceed 0,15.

PS (R-PDSO-G8)

PLASTIC SMALL OUTLINE

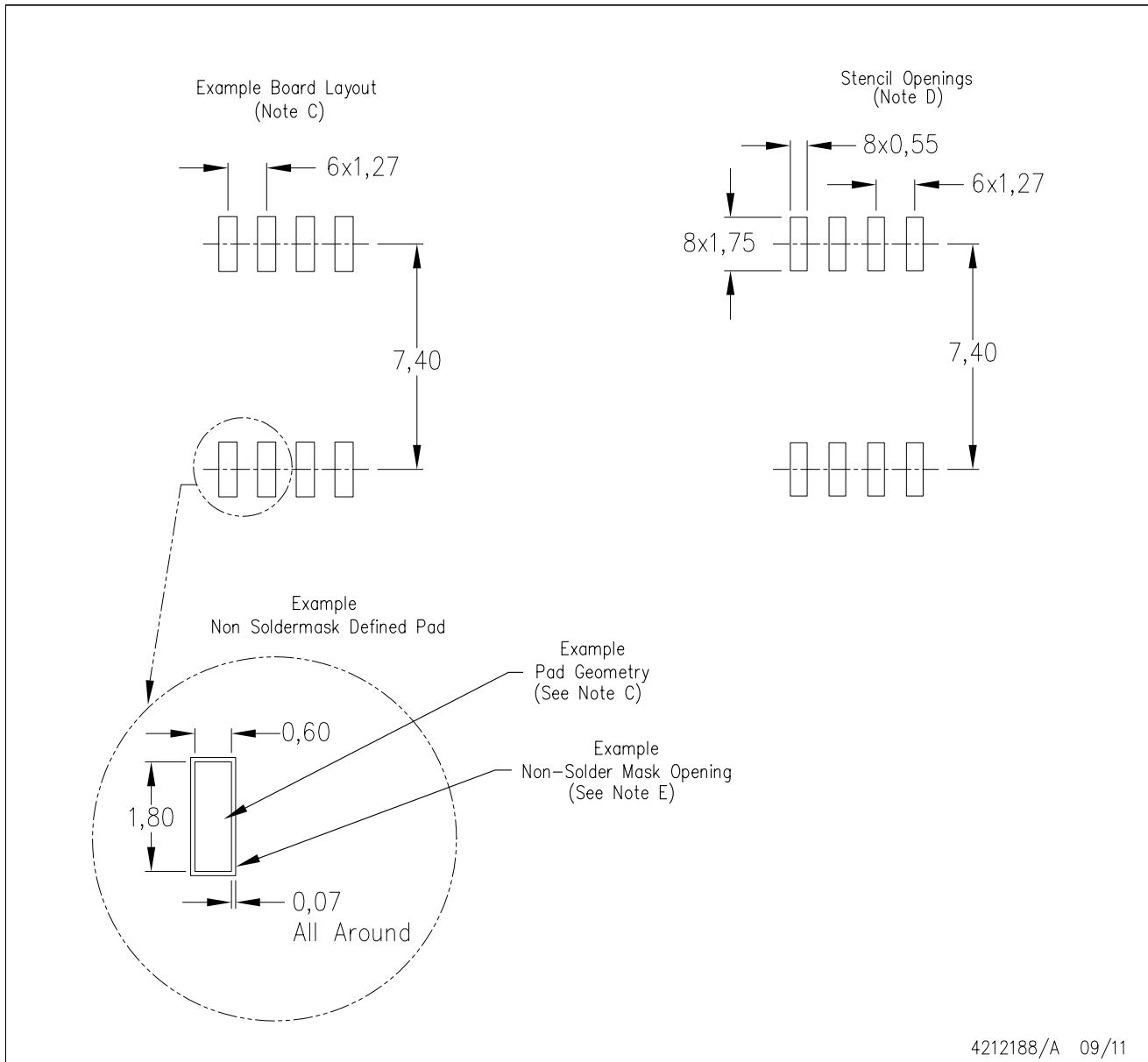

- NOTES:
- A. All linear dimensions are in millimeters.
 - B. This drawing is subject to change without notice.
 - C. Publication IPC-7351 is recommended for alternate designs.
 - D. Laser cutting apertures with trapezoidal walls and also rounding corners will offer better paste release. Customers should contact their board assembly site for stencil design recommendations. Refer to IPC-7525 for other stencil recommendations.
 - E. Customers should contact their board fabrication site for solder mask tolerances between and around signal pads.

P (R-PDIP-T8)

PLASTIC DUAL-IN-LINE PACKAGE



4040082/E 04/2010

- NOTES:
- A. All linear dimensions are in inches (millimeters).
 - B. This drawing is subject to change without notice.
 - C. Falls within JEDEC MS-001 variation BA.

IMPORTANT NOTICE AND DISCLAIMER

TI PROVIDES TECHNICAL AND RELIABILITY DATA (INCLUDING DATA SHEETS), DESIGN RESOURCES (INCLUDING REFERENCE DESIGNS), APPLICATION OR OTHER DESIGN ADVICE, WEB TOOLS, SAFETY INFORMATION, AND OTHER RESOURCES "AS IS" AND WITH ALL FAULTS, AND DISCLAIMS ALL WARRANTIES, EXPRESS AND IMPLIED, INCLUDING WITHOUT LIMITATION ANY IMPLIED WARRANTIES OF MERCHANTABILITY, FITNESS FOR A PARTICULAR PURPOSE OR NON-INFRINGEMENT OF THIRD PARTY INTELLECTUAL PROPERTY RIGHTS.

These resources are intended for skilled developers designing with TI products. You are solely responsible for (1) selecting the appropriate TI products for your application, (2) designing, validating and testing your application, and (3) ensuring your application meets applicable standards, and any other safety, security, regulatory or other requirements.

These resources are subject to change without notice. TI grants you permission to use these resources only for development of an application that uses the TI products described in the resource. Other reproduction and display of these resources is prohibited. No license is granted to any other TI intellectual property right or to any third party intellectual property right. TI disclaims responsibility for, and you will fully indemnify TI and its representatives against, any claims, damages, costs, losses, and liabilities arising out of your use of these resources.

TI's products are provided subject to [TI's Terms of Sale](#) or other applicable terms available either on [ti.com](https://www.ti.com) or provided in conjunction with such TI products. TI's provision of these resources does not expand or otherwise alter TI's applicable warranties or warranty disclaimers for TI products.

TI objects to and rejects any additional or different terms you may have proposed.

Mailing Address: Texas Instruments, Post Office Box 655303, Dallas, Texas 75265
Copyright © 2024, Texas Instruments Incorporated

Looking for pricing, stock, or lifecycle information?

Click below to explore more details on WIN SOURCE:

 [View UA741CP](#) on WIN SOURCE

 [Texas Instruments](#) Information

Optimize Your Supply Chain with WIN SOURCE Solutions

-  Global Sourcing Solution
-  Obsolete Management
-  Cost Control Management
-  Shortage Management
-  Alternative Solution
-  Excess Inventory Management