

TXB0104 4-Bit Bidirectional Voltage-Level Translator With Automatic Direction Sensing and ± 15 -kV ESD Protection

1 Features

- 1.2-V to 3.6-V on A port and 1.65-V to 5.5-V on B port ($V_{CCA} \leq V_{CCB}$)
- V_{CC} isolation feature: if either V_{CC} input ss at GND, all outputs are in the high-impedance state
- Output enable (OE) input circuit referenced to V_{CCA}
- Low power consumption, 5- μ A maximum I_{CC}
- I_{OFF} supports partial power-down mode operation
- Latch-up Performance Exceeds 100 mA Per JESD 78, Class II
- ESD Protection Exceeds JESD 22
 - A Port:
 - 2500-V Human-Body Model (A114-B)
 - 1500-V Charged-Device Model (C101)
 - B Port:
 - ± 15 -kV Human-Body Model (A114-B)
 - 1500-V Charged-Device Model (C101)

2 Applications

- Headsets
- Smartphones
- Tablets
- Desktop PC

3 Description

This TXB0104 4-bit noninverting translator uses two separate configurable power-supply rails. The A port is designed to track V_{CCA} . V_{CCA} accepts any supply voltage from 1.2 V to 3.6 V. The B port is designed to track V_{CCB} . V_{CCB} accepts any supply voltage from 1.65 V to 5.5 V. This allows for universal low-voltage bidirectional translation between any of the 1.2-V, 1.5-V, 1.8-V, 2.5-V, 3.3-V, and 5-V voltage nodes. V_{CCA} must not exceed V_{CCB} .

When the OE input is low, all outputs are placed in the high-impedance state. To ensure the high-impedance state during power up or power down, OE must be tied to GND through a pulldown resistor. The current sourcing capability of the driver determines the minimum value of the resistor.

The TXB0104 device is designed so the OE input circuit is supplied by V_{CCA} .

This device is fully specified for partial power-down applications using I_{OFF} . The I_{OFF} circuitry disables the outputs, which prevents damaging current backflow through the device when the device is powered down.

Device Information

(1) PART NUMBER	PACKAGE	BODY SIZE (NOM)
TXB0104RUT	UQFN (12)	2.00 mm \times 1.70 mm
TXB0104D	SOIC (14)	8.65 mm \times 3.91 mm
TXB0104ZXU/GXU	BGA MICROSTAR JUNIOR™ (12)	2.00 mm \times 2.50 mm
TXB0104PW	TSSOP (14)	5.00 mm \times 4.40 mm
TXB0104RGY	VQFN (14)	3.50 mm \times 3.50 mm
TXB0104YZT	DSBGA (12)	1.40 mm \times 1.90 mm
TXB0104NMN	NFBGA (12)	2.00 mm \times 2.50 mm

- (1) For all available packages, see the orderable addendum at the end of the data sheet.

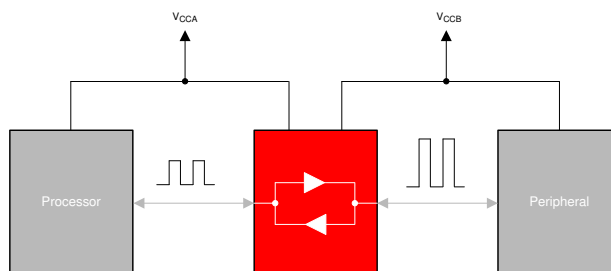

Typical Application Block Diagram for TXB010X



Table of Contents

1 Features	1	6.18 Typical Characteristics.....	13
2 Applications	1	7 Parameter Measurement Information	14
3 Description	1	8 Detailed Description	16
4 Revision History	2	8.1 Overview.....	16
5 Pin Configuration and Functions	3	8.2 Functional Block Diagram.....	16
6 Specifications	5	8.3 Feature Description.....	17
6.1 Absolute Maximum Ratings.....	5	8.4 Device Functional Modes.....	19
6.2 ESD Ratings.....	5	9 Application and Implementation	20
6.3 Recommended Operating Conditions.....	6	9.1 Application Information.....	20
6.4 Thermal Information.....	6	9.2 Typical Application.....	20
6.5 Electrical Characteristics.....	7	10 Power Supply Recommendations	22
6.6 Timing Requirements: $V_{CCA} = 1.2\text{ V}$	8	11 Layout	22
6.7 Timing Requirements: $V_{CCA} = 1.5\text{ V} \pm 0.1\text{ V}$	8	11.1 Layout Guidelines.....	22
6.8 Timing Requirements: $V_{CCA} = 1.8\text{ V} \pm 0.15\text{ V}$	8	11.2 Layout Example.....	22
6.9 Timing Requirements: $V_{CCA} = 2.5\text{ V} \pm 0.2\text{ V}$	8	12 Device and Documentation Support	23
6.10 Timing Requirements: $V_{CCA} = 3.3\text{ V} \pm 0.3\text{ V}$	8	12.1 Receiving Notification of Documentation Updates.....	23
6.11 Switching Characteristics: $V_{CCA} = 1.2\text{ V}$	9	12.2 Support Resources.....	23
6.12 Switching Characteristics: $V_{CCA} = 1.5\text{ V} \pm 0.1\text{ V}$	9	12.3 Trademarks.....	23
6.13 Switching Characteristics: $V_{CCA} = 1.8\text{ V} \pm 0.15\text{ V}$	10	12.4 Electrostatic Discharge Caution.....	23
6.14 Switching Characteristics: $V_{CCA} = 2.5\text{ V} \pm 0.2\text{ V}$	10	12.5 Glossary.....	23
6.15 Switching Characteristics: $V_{CCA} = 3.3\text{ V} \pm 0.3\text{ V}$	11	13 Mechanical, Packaging, and Orderable Information	23
6.16 Operating Characteristics: $V_{CCA} = 1.2\text{ V}$ to 1.5 V , $V_{CCB} = 1.5\text{ V}$ to 1.8 V	12		
6.17 Operating Characteristics: $V_{CCA} = 1.8\text{ V}$ to 3.3 V , $V_{CCB} = 1.8\text{ V}$ to 5 V	12		

4 Revision History

NOTE: Page numbers for previous revisions may differ from page numbers in the current version.

Changes from Revision I (March 2018) to Revision J (October 2020)	Page
• Updated the numbering format for tables, figures, and cross-references throughout the document.....	1
• Added NMN Package, 12-Pin NFBGA pinout drawing in <i>Pin Configuration and Functions</i> section.....	3
Changes from Revision H (January 2018) to Revision I (March 2018)	Page
• Updated <i>Pin Functions</i> table	3
• Added <i>Pin Assignments</i> table for YZT package	3
• Added <i>Pin Assignments</i> table for GXU and ZXU package	3
• Updated <i>Layout Example</i>	22
Changes from Revision G (November 2014) to Revision H (January 2018)	Page
• Added Package, families to Package, pinout drawings in <i>Pin Configuration and Functions</i> section	3
• Added junction temperature range in <i>Absolute Maximum Rating</i> table.....	5
• Changed unit from V to kV in <i>ESD Ratings</i> table.....	5
Changes from Revision F (May 2012) to Revision G (November 2014)	Page
• Added <i>Pin Configuration and Functions</i> section, <i>Handling Rating</i> table, <i>Feature Description</i> section, <i>Device Functional Modes</i> , <i>Application and Implementation</i> section, <i>Power Supply Recommendations</i> section, <i>Layout</i> section, <i>Device and Documentation Support</i> section, and <i>Mechanical, Packaging, and Orderable Information</i> section	1

5 Pin Configuration and Functions

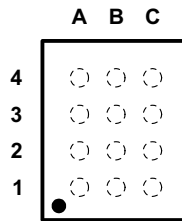

Figure 5-1. GXU and ZXU Package, 12-Pin BGA Microstar Junior (Top View)

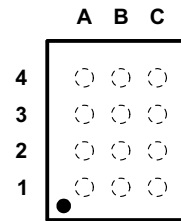

Figure 5-2. NMN Package, 12-Pin NFBGA (Top View)

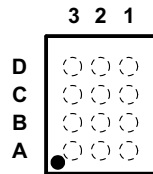
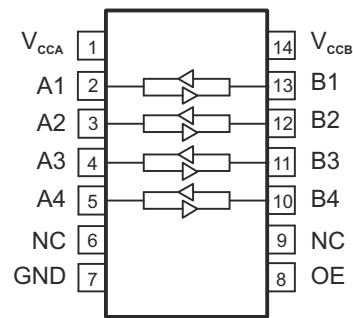
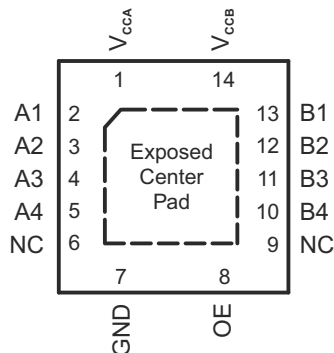

Figure 5-3. YZT Package, 12-Pin DSBGA (Top View)



NC – No internal connection

Figure 5-4. D or PW Package, 14-Pin SOIC or TSSOP (Top View)



NC – No internal connection

Figure 5-5. RGY Package, 14-Pin VQFN With Exposed Thermal Pad (Top View)

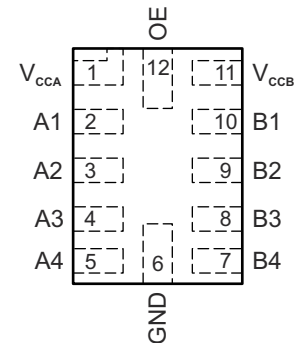

Figure 5-6. RUT Package, 12-Pin UQFN (Top View)

Table 5-1. Pin Functions

NAME	PIN					I/O	DESCRIPTION
	D, PW	RGY	RUT	GXU, ZXU, NMN	YZT		
A1	2	2	2	A1	A3	I/O	Input/output 1. Referenced to V_{CCA} .
A2	3	3	3	A2	B3	I/O	Input/output 2. Referenced to V_{CCA} .
A3	4	4	4	A3	C3	I/O	Input/output 3. Referenced to V_{CCA} .
A4	5	5	5	A4	D3	I/O	Input/output 4. Referenced to V_{CCA} .
B1	13	13	10	C1	A1	I/O	Input/output 1. Referenced to V_{CCB} .
B2	12	12	9	C2	B1	I/O	Input/output 2. Referenced to V_{CCB} .
B3	11	11	8	C3	C1	I/O	Input/output 3. Referenced to V_{CCB} .
B4	10	10	7	C4	D1	I/O	Input/output 4. Referenced to V_{CCB} .
GND	7	7	6	B4	D2	—	Ground
NC	6, 9	6,9	—	—	—	—	No connection. Not internally connected.
OE	8	8	12	B3	C2	I	Tri-state output-mode enable. Pull OE low to place all outputs in tri-state mode. Referenced to V_{CCA} .
V_{CCA}	1	1	1	B2	B2	—	A-port supply voltage $1.2\text{ V} \leq V_{CCA} \leq 3.6\text{ V}$ and $V_{CCA} \leq V_{CCB}$.
V_{CCB}	14	14	11	B1	A2	—	B-port supply voltage $1.65\text{ V} \leq V_{CCB} \leq 5.5\text{ V}$.
Thermal pad	—	—	—	—	—	—	For the RGY package, the exposed center thermal pad must either be connected to Ground or left electrically open.

Table 5-2. Pin Assignments: NMN, GXU and ZXU Package

	A	B	C
4	A4	GND	B4
3	A3	OE	B3
2	A2	V_{CCA}	B2
1	A1	V_{CCB}	B1

Table 5-3. Pin Assignments: YZT Package

	3	2	1
D	A4	GND	B4
C	A3	OE	B3
B	A2	V_{CCA}	B2
A	A1	V_{CCB}	B1

6 Specifications

6.1 Absolute Maximum Ratings

over operating free-air temperature range (unless otherwise noted)

(1)		MIN	MAX	UNIT
Supply voltage, V_{CCA}		-0.5	4.6	V
Supply voltage, V_{CCB}		-0.5	6.5	
Input voltage, V_I	A port	-0.5	4.6	V
	B port	-0.5	6.5	
Voltage applied to any output in the high-impedance or power-off state, V_O	A port	-0.5	4.6	V
	B port	-0.5	6.5	
Voltage applied to any output in the high or low state, V_O (2)	A port	-0.5	$V_{CCA} + 0.5$	V
	B port	-0.5	$V_{CCB} + 0.5$	
Input clamp current, I_{IK}	$V_I < 0$		-50	mA
Output clamp current, I_{OK}	$V_O < 0$		-50	mA
Continuous output current, I_O		-50	50	mA
Continuous current through V_{CCA} , V_{CCB} , or GND		-100	100	mA
Junction temperature range, T_J			150	°C
Storage temperature range, T_{stg}		-65	150	°C

- (1) Stresses beyond those listed under *Absolute Maximum Ratings* may cause permanent damage to the device. These are stress ratings only, and functional operation of the device at these or any other conditions beyond those indicated under [Section 6.3](#) is not implied. Exposure to absolute-maximum-rated conditions for extended periods may affect device reliability.
- (2) The value of V_{CCA} and V_{CCB} are provided in the recommended operating conditions table.

6.2 ESD Ratings

			VALUE	UNIT	
$V_{(ESD)}$	Electrostatic discharge	Human-body model (HBM), per ANSI/ESDA/JEDEC JS-001(1)	A port	±2.5	kV
		Human-body model (HBM), per ANSI/ESDA/JEDEC JS-001(1)	B port	±15	
		Charged-device model (CDM), per JEDEC specification JESD22-C101(2)	A port	±1.5	
		Charged-device model (CDM), per JEDEC specification JESD22-C101(2)	B port	±1.5	

- (1) JEDEC document JEP155 states that 500-V HBM allows safe manufacturing with a standard ESD control process.
- (2) JEDEC document JEP157 states that 250-V CDM allows safe manufacturing with a standard ESD control process.

6.3 Recommended Operating Conditions

over operating free-air temperature range (unless otherwise noted)^{(1) (2)}

			MIN	MAX	UNIT	
V _{CCA}	Supply voltage		1.2	3.6	V	
V _{CCB}	Supply voltage		1.65	5.5		
V _{IH}	High-level input voltage	Data inputs	V _{CCA} = 1.2 V to 3.6 V V _{CCB} = 1.65 V to 5.5 V	V _{CCI} × 0.65 ⁽³⁾	V _{CCI}	V
		OE	V _{CCA} = 1.2 V to 3.6 V V _{CCB} = 1.65 V to 5.5 V	V _{CCA} × 0.65	5.5	
V _{IL}	Low-level input voltage	Data inputs	V _{CCA} = 1.2 V to 5.5 V V _{CCB} = 1.65 V to 5.5 V	0	V _{CCI} × 0.35 ⁽³⁾	V
		OE	V _{CCA} = 1.2 V to 3.6 V V _{CCB} = 1.65 V to 5.5 V	0	V _{CCA} × 0.35	
V _O	Voltage applied to any output in the high-impedance or power-off state	A-port	V _{CCA} = 1.2 V to 3.6 V V _{CCB} = 1.65 V to 5.5 V	0	3.6	V
		B-port	V _{CCA} = 1.2 V to 3.6 V V _{CCB} = 1.65 V to 5.5 V	0	5.5	
Δt/Δv	Input transition rise or fall rate	A-port inputs	V _{CCA} = 1.2 V to 3.6 V V _{CCB} = 1.65 V to 5.5 V		40	ns/V
		B-port inputs	V _{CCA} = 1.2 V to 3.6 V	V _{CCB} = 1.65 V to 3.6 V	40	
				V _{CCB} = 4.5 V to 5.5 V	30	
T _A	Operating free-air temperature		-40	85	°C	

(1) The A and B sides of an unused data I/O pair must be held in the same state, that is, both at V_{CCI} or both at GND.

(2) V_{CCA} must be less than or equal to V_{CCB} and must not exceed 3.6 V.

(3) V_{CCI} is the supply voltage associated with the input port.

6.4 Thermal Information

THERMAL METRIC ⁽¹⁾	TXB0104							UNIT	
	D	GXU/ZXU	PW	RGY	RUT	YZT	NMN		
	14 PINS	12 PINS	14 PINS	14 PINS	12 PINS	12 PINS	12 PINS		
R _{θJA}	Junction-to-ambient thermal resistance	90.7	127.1	121.0	52.8	119.8	89.2	134.3	°C/W
R _{θJC(top)}	Junction-to-case (top) thermal resistance	50.5	92.8	50.0	67.7	42.6	0.9	90.7	
R _{θJB}	Junction-to-board thermal resistance	45.4	62.2	62.8	28.9	52.5	14.4	88.4	
Ψ _{JT}	Junction-to-top characterization parameter	14.7	2.3	6.4	2.6	0.7	3.0	4.3	
Ψ _{JB}	Junction-to-board characterization parameter	45.1	62.2	62.2	29.0	52.3	14.4	89.3	
R _{θJC(bot)}	Junction-to-case (bottom) thermal resistance	—	—	—	—	—	—	—	

(1) For more information about traditional and new thermal metrics, see the [IC Package Thermal Metrics](#) application report.

6.5 Electrical Characteristics

over recommended operating free-air temperature range (unless otherwise noted)

PARAMETER ^{(1) (2)}	TEST CONDITIONS	V _{CCA}	V _{CCB}	T _A = 25°C			–40°C to 85°C		UNIT
				MIN	TYP	MAX	MIN	MAX	
V _{OHA} Port A output high voltage	I _{OH} = –20 μA	1.2 V		1.1					V
		1.4 V to 3.6 V					V _{CCA} – 0.4		
V _{OLA} Port A output low voltage	I _{OL} = 20 μA	1.2 V		0.3					V
		1.4 V to 3.6 V					0.4		
V _{OHB} Port B output high voltage	I _{OH} = –20 μA		1.65 V to 5.5 V				V _{CCB} – 0.4		V
V _{OLB} Port B output low voltage	I _{OL} = 20 μA		1.65 V to 5.5 V				0.4		V
I _I Inflection-point current	OE: V _I = V _{CCI} or GND	1.2 V to 3.6 V	1.65 V to 5.5 V	–1		1	–2	2	μA
I _{off} Off-state current	A port: V _I or V _O = 0 to 3.6 V	0 V	0 V to 5.5 V	–1		1	–2	2	μA
	B port: V _I or V _O = 0 to 5.5 V	0 V to 3.6 V	0 V	–1		1	–2	2	
I _{OZ} High-impedance-state output current	A or B port: OE = GND	1.2 V to 3.6 V	1.65 V to 5.5 V	–1		1	–2	2	μA
I _{CCA} V _{CCA} supply current	V _I = V _{CCI} or GND I _O = 0	1.2 V	1.65 V to 5.5 V	0.06					μA
		1.4 V to 3.6 V	1.65 V to 5.5 V				5		
		3.6 V	0 V				2		
		0 V	5.5 V				–2		
I _{CCB} V _{CCB} supply current	V _I = V _{CCI} or GND I _O = 0	1.2 V	1.65 V to 5.5 V	3.4					μA
		1.4 V to 3.6 V	1.65 V to 5.5 V				5		
		3.6 V	0 V				–2		
		0 V	5.5 V				2		
I _{CCA} + I _{CCB} Combined supply current	V _I = V _{CCI} or GND I _O = 0	1.2 V	1.65 V to 5.5 V	3.5					μA
		1.4 V to 3.6 V	1.65 V to 5.5 V				10		
I _{CCZA} High-impedance state, V _{CCA} supply current	V _I = V _{CCI} or GND I _O = 0, OE = GND	1.2 V	1.65 V to 5.5 V	0.05					μA
		1.4 V to 3.6 V	1.65 V to 5.5 V				5		
I _{CCZB} High-impedance state, V _{CCB} supply current	V _I = V _{CCI} or GND I _O = 0, OE = GND	1.2 V	1.65 V to 5.5 V	3.3					μA
		1.4 V to 3.6 V	1.65 V to 5.5 V				5		
C _i Input capacitance	OE	1.2 V to 3.6 V	1.65 V to 5.5 V	3			4		pF
C _{io} Input-to-output internal capacitance	A port	1.2 V to 3.6 V	1.65 V to 5.5 V	5			6		pF
	B port	1.2 V to 3.6 V	1.65 V to 5.5 V	11			14		

- (1) V_{CCI} is the supply voltage associated with the input port.
(2) V_{CCO} is the supply voltage associated with the output port.

6.6 Timing Requirements: $V_{CCA} = 1.2\text{ V}$

$T_A = 25^\circ\text{C}$, $V_{CCA} = 1.2\text{ V}$

		$V_{CCB} = 1.8\text{ V}$			$V_{CCB} = 2.5\text{ V}$			$V_{CCB} = 3.3\text{ V}$			$V_{CCB} = 5\text{ V}$			UNIT
		MIN	TYP	MAX	MIN	TYP	MAX	MIN	TYP	MAX	MIN	TYP	MAX	
Data rate		20			20			20			20			Mbps
t_w	Pulse duration	50			50			50			50			ns

6.7 Timing Requirements: $V_{CCA} = 1.5\text{ V} \pm 0.1\text{ V}$

over recommended operating free-air temperature range, $V_{CCA} = 1.5\text{ V} \pm 0.1\text{ V}$ (unless otherwise noted)

		$V_{CCB} = 1.8\text{ V} \pm 0.15\text{ V}$		$V_{CCB} = 2.5\text{ V} \pm 0.2\text{ V}$		$V_{CCB} = 3.3\text{ V} \pm 0.3\text{ V}$		$V_{CCB} = 5\text{ V} \pm 0.5\text{ V}$		UNIT
		MIN	MAX	MIN	MAX	MIN	MAX	MIN	MAX	
Data rate		40		40		40		40		Mbps
t_w	Pulse duration	25		25		25		25		ns

6.8 Timing Requirements: $V_{CCA} = 1.8\text{ V} \pm 0.15\text{ V}$

over recommended operating free-air temperature range, $V_{CCA} = 1.8\text{ V} \pm 0.15\text{ V}$ (unless otherwise noted)

		$V_{CCB} = 1.8\text{ V} \pm 0.15\text{ V}$		$V_{CCB} = 2.5\text{ V} \pm 0.2\text{ V}$		$V_{CCB} = 3.3\text{ V} \pm 0.3\text{ V}$		$V_{CCB} = 5\text{ V} \pm 0.5\text{ V}$		UNIT
		MIN	MAX	MIN	MAX	MIN	MAX	MIN	MAX	
Data rate		60		60		60		60		Mbps
t_w	Pulse duration	17		17		17		17		ns

6.9 Timing Requirements: $V_{CCA} = 2.5\text{ V} \pm 0.2\text{ V}$

over recommended operating free-air temperature range, $V_{CCA} = 2.5\text{ V} \pm 0.2\text{ V}$ (unless otherwise noted)

		$V_{CCB} = 2.5\text{ V} \pm 0.2\text{ V}$		$V_{CCB} = 3.3\text{ V} \pm 0.3\text{ V}$		$V_{CCB} = 5\text{ V} \pm 0.5\text{ V}$		UNIT
		MIN	MAX	MIN	MAX	MIN	MAX	
Data rate		100		100		100		Mbps
t_w	Pulse duration	10		10		10		ns

6.10 Timing Requirements: $V_{CCA} = 3.3\text{ V} \pm 0.3\text{ V}$

over recommended operating free-air temperature range, $V_{CCA} = 3.3\text{ V} \pm 0.3\text{ V}$ (unless otherwise noted)

		$V_{CCB} = 3.3\text{ V} \pm 0.3\text{ V}$		$V_{CCB} = 5\text{ V} \pm 0.5\text{ V}$		UNIT
		MIN	MAX	MIN	MAX	
Data rate		100		100		Mbps
t_w	Pulse duration	10		10		ns

6.11 Switching Characteristics: $V_{CCA} = 1.2\text{ V}$

 $T_A = 25^\circ\text{C}$, $V_{CCA} = 1.2\text{ V}$

PARAMETER	TEST CONDITIONS	$V_{CCB} = 1.8\text{ V}$			$V_{CCB} = 2.5\text{ V}$			$V_{CCB} = 3.3\text{ V}$			$V_{CCB} = 5\text{ V}$			UNIT			
		MIN	TYP	MAX	MIN	TYP	MAX	MIN	TYP	MAX	MIN	TYP	MAX				
t_{pd}	Propagation delay time	A-to-B	6.9			5.7			5.3			5.5			ns		
		B-to-A	7.4			6.4			6			5.8					
t_{en}	Enable time	OE-to-A	1			1			1			1			μs		
		OE-to-B	1			1			1			1					
t_{dis}	Disable time	OE-to-A	18			15			14			14			ns		
		OE-to-B	20			17			16			16					
t_{rA} , t_{fA}	Input rise time, input fall time	A-port rise and fall times			4.2			4.2			4.2			ns			
t_{rB} , t_{fB}	Input rise time, input fall time	B-port rise and fall times			2.1			1.5			1.2			1.1			ns
$t_{SK(O)}$	Skew (time), output	Channel-to-channel skew			0.4			0.5			0.5			1.4			ns
	Maximum data rate	20			20			20			20			Mbps			

6.12 Switching Characteristics: $V_{CCA} = 1.5\text{ V} \pm 0.1\text{ V}$

 over recommended operating free-air temperature range, $V_{CCA} = 1.5\text{ V} \pm 0.1\text{ V}$ (unless otherwise noted)

PARAMETER	TEST CONDITIONS	$V_{CCB} = 1.8\text{ V} \pm 0.15\text{ V}$		$V_{CCB} = 2.5\text{ V} \pm 0.2\text{ V}$		$V_{CCB} = 3.3\text{ V} \pm 0.3\text{ V}$		$V_{CCB} = 5\text{ V} \pm 0.5\text{ V}$		UNIT		
		MIN	MAX	MIN	MAX	MIN	MAX	MIN	MAX			
t_{pd}	Propagation delay time	A-to-B	1.4	12.9	1.2	10.1	1.1	10	0.8	9.9	ns	
		B-to-A	0.9	14.2	0.7	12	0.4	11.7	0.3	13.7		
t_{en}	Enable time	OE-to-A	1		1		1		1		μs	
		OE-to-B	1		1		1		1			
t_{dis}	Disable time	OE-to-A	5.9	31	5.7	25.9	5.6	23	5.7	22.4	ns	
		OE-to-B	5.4	30.3	4.9	22.8	4.8	20	4.9	19.5		
t_{rA} , t_{fA}	Input rise time, input fall time	A-port rise and fall times		1.4	5.1	1.4	5.1	1.4	5.1	1.4	5.1	ns
t_{rB} , t_{fB}	Input rise time, input fall time	B-port rise and fall times		0.9	4.5	0.6	3.2	0.5	2.8	0.4	2.7	ns
$t_{SK(O)}$	Skew (time), output	Channel-to-channel skew		0.5		0.5		0.5		0.5		ns
	Maximum data rate	40		40		40		40		Mbps		

6.13 Switching Characteristics: $V_{CCA} = 1.8\text{ V} \pm 0.15\text{ V}$

over recommended operating free-air temperature range, $V_{CCA} = 1.8\text{ V} \pm 0.15\text{ V}$ (unless otherwise noted)

PARAMETER	TEST CONDITIONS	$V_{CCB} = 1.8\text{ V} \pm 0.15\text{ V}$		$V_{CCB} = 2.5\text{ V} \pm 0.2\text{ V}$		$V_{CCB} = 3.3\text{ V} \pm 0.3\text{ V}$		$V_{CCB} = 5\text{ V} \pm 0.5\text{ V}$		UNIT	
		MIN	MAX	MIN	MAX	MIN	MAX	MIN	MAX		
t_{pd}	Propagation delay time	A-to-B	1.6	11	1.4	7.7	1.3	6.8	1.2	6.5	ns
		B-to-A	1.5	12	1.3	8.4	1	7.6	0.9	7.1	
t_{en}	Enable time	OE-to-A		1		1		1		1	μs
		OE-to-B		1		1		1		1	
t_{dis}	Disable time	OE-to-A	5.9	31	5.1	21.3	5	19.3	5	17.4	ns
		OE-to-B	5.4	30.3	4.4	20.8	4.2	17.9	4.3	16.3	
t_{rA}, t_{fA}	Input rise time, input fall time	A-port rise and fall times	1	4.2	1.1	4.1	1.1	4.1	1.1	4.1	ns
t_{rB}, t_{fB}	Input rise time, input fall time	B-port rise and fall times	0.9	3.8	0.6	3.2	0.5	2.8	0.4	2.7	ns
$t_{SK(O)}$	Skew (time), output	Channel-to-channel skew		0.5		0.5		0.5		0.5	ns
	Maximum data rate		60		60		60		60	Mbps	

6.14 Switching Characteristics: $V_{CCA} = 2.5\text{ V} \pm 0.2\text{ V}$

over recommended operating free-air temperature range, $V_{CCA} = 2.5\text{ V} \pm 0.2\text{ V}$ (unless otherwise noted)

PARAMETER	TEST CONDITIONS	$V_{CCB} = 2.5\text{ V} \pm 0.2\text{ V}$		$V_{CCB} = 3.3\text{ V} \pm 0.3\text{ V}$		$V_{CCB} = 5\text{ V} \pm 0.5\text{ V}$		UNIT	
		MIN	MAX	MIN	MAX	MIN	MAX		
t_{pd}	Propagation delay time	A-to-B	1.1	6.3	1	5.2	0.9	4.7	ns
		B-to-A	1.2	6.6	1.1	5.1	0.9	4.4	
t_{en}	Enable time	OE-to-A		1		1		1	μs
		OE-to-B		1		1		1	
t_{dis}	Disable time	OE-to-A	5.1	21.3	4.6	15.2	4.6	13.2	ns
		OE-to-B	4.4	20.8	3.8	16	3.9	13.9	
t_{rA}, t_{fA}	Input rise time, input fall time	A-port rise and fall times	0.8	3	0.8	3	0.8	3	ns
t_{rB}, t_{fB}	Input rise time, input fall time	B-port rise and fall times	0.7	2.6	0.5	2.8	0.4	2.7	ns
$t_{SK(O)}$	Skew (time), output	Channel-to-channel skew		0.5		0.5		0.5	ns
	Maximum data rate		100		100		100		Mbps

6.15 Switching Characteristics: $V_{CCA} = 3.3\text{ V} \pm 0.3\text{ V}$

over recommended operating free-air temperature range, $V_{CCA} = 3.3\text{ V} \pm 0.3\text{ V}$ (unless otherwise noted)

PARAMETER	TEST CONDITIONS	$V_{CCB} = 3.3\text{ V} \pm 0.3\text{ V}$		$V_{CCB} = 5\text{ V} \pm 0.5\text{ V}$		UNIT	
		MIN	MAX	MIN	MAX		
t_{pd}	Propagation delay time	A-to-B	0.9	4.7	0.8	4	ns
		B-to-A	1	4.9	0.9	3.8	
t_{en}	Enable time	OE-to-A		1		1	μs
		OE-to-B		1		1	
t_{dis}	Disable time	OE-to-A	4.6	15.2	4.3	12.1	ns
		OE-to-B	3.8	16	3.4	13.2	
t_{rA}, t_{fA}	Input rise time, input fall time	A-port rise and fall times	0.7	2.5	0.7	2.5	ns
t_{rB}, t_{fB}	Input rise time, input fall time	B-port rise and fall times	0.5	2.1	0.4	2.7	ns
$t_{SK(O)}$	Skew (time), output	Channel-to-channel skew		0.5		0.5	ns
	Maximum data rate		100		100		Mbps

6.16 Operating Characteristics: $V_{CCA} = 1.2\text{ V to }1.5\text{ V}$, $V_{CCB} = 1.5\text{ V to }1.8\text{ V}$

 $T_A = 25^\circ\text{C}$

PARAMETER	TEST CONDITIONS	$V_{CCA} = 1.2\text{ V}, V_{CCB} = 1.5\text{ V}$			$V_{CCA} = 1.2\text{ V}, V_{CCB} = 1.8\text{ V}$			$V_{CCA} = 1.5\text{ V}, V_{CCB} = 1.8\text{ V}$			UNIT	
		MIN	TYP	MAX	MIN	TYP	MAX	MIN	TYP	MAX		
C_{pdA} Power dissipation capacitance	$C_L = 0$ $f = 10\text{ MHz}$ $t_r = t_f = 1\text{ ns}$	A-port input, B-port output	7.8			10			9			pF
		B-port input, A-port output	12			11			11			
C_{pdB} Power dissipation capacitance	OE = V_{CCA} (outputs enabled)	A-port input, B-port output	38.1			28			28			
		B-port input, A-port output	25.4			19			18			
C_{pdA} Power dissipation capacitance	$C_L = 0$ $f = 10\text{ MHz}$ $t_r = t_f = 1\text{ ns}$	A-port input, B-port output	0.01			0.01			0.01			pF
		B-port input, A-port output	0.01			0.01			0.01			
C_{pdB} Power dissipation capacitance	OE = GND (outputs disabled)	A-port input, B-port output	0.01			0.01			0.01			
		B-port input, A-port output	0.01			0.01			0.01			

6.17 Operating Characteristics: $V_{CCA} = 1.8\text{ V to }3.3\text{ V}$, $V_{CCB} = 1.8\text{ V to }5\text{ V}$

 $T_A = 25^\circ\text{C}$

PARAMETER	TEST CONDITIONS	$V_{CCA} = 1.8\text{ V}, V_{CCB} = 1.8\text{ V}$			$V_{CCA} = 2.5\text{ V}, V_{CCB} = 2.5\text{ V}$			$V_{CCA} = 2.5\text{ V}, V_{CCB} = 5\text{ V}$			$V_{CCA} = 3.3\text{ V}, V_{CCB} = 3.3\text{ V to }5\text{ V}$			UNIT	
		MIN	TYP	MAX	MIN	TYP	MAX	MIN	TYP	MAX	MIN	TYP	MAX		
C_{pdA} Power dissipation capacitance	$C_L = 0$ $f = 10\text{ MHz}$ $t_r = t_f = 1\text{ ns}$	A-port input, B-port output	8			8			8			9			pF
		B-port input, A-port output	11			11			11			11			
C_{pdB} Power dissipation capacitance	OE = V_{CCA} (outputs enabled)	A-port input, B-port output	28			29			29			29			
		B-port input, A-port output	18			19			21			22			
C_{pdA} Power dissipation capacitance	$C_L = 0$ $f = 10\text{ MHz}$ $t_r = t_f = 1\text{ ns}$	A-port input, B-port output	0.01			0.01			0.01			0.01			pF
		B-port input, A-port output	0.01			0.01			0.01			0.01			
C_{pdB} Power dissipation capacitance	OE = GND (outputs disabled)	A-port input, B-port output	0.01			0.01			0.01			0.03			
		B-port input, A-port output	0.01			0.01			0.01			0.04			

6.18 Typical Characteristics

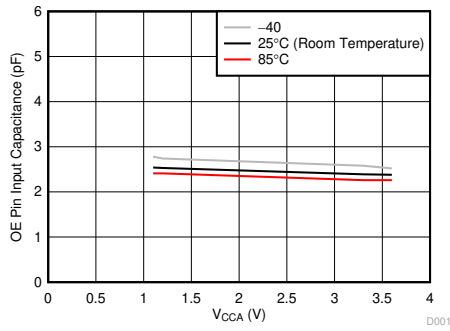

V_{CCB} = 3.3 V

Figure 6-1. Input Capacitance for OE Pin (C_i) vs Power Supply (V_{CCA})

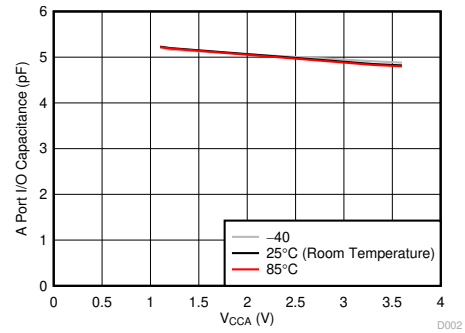

V_{CCB} = 3.3 V

Figure 6-2. Capacitance for A port I/O Pins (C_{iO}) vs Power Supply (V_{CCA})

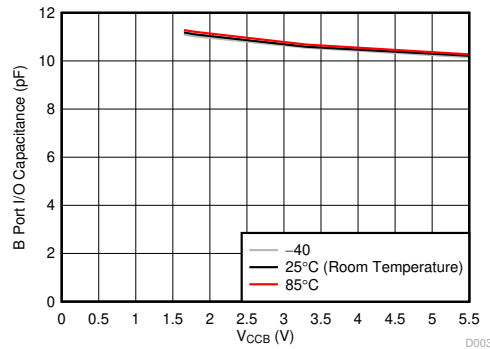

V_{CCA} = 1.8 V

Figure 6-3. Capacitance for B Port I/O Pins (C_{iO}) vs Power Supply (V_{CCB})

7 Parameter Measurement Information

Unless otherwise noted, all input pulses are supplied by generators that have the following characteristics:

- PRR 10 MHz
- $Z_O = 50 \Omega$
- $dv/dt \geq 1 \text{ V/ns}$

Note

All parameters and waveforms are not applicable to all devices.

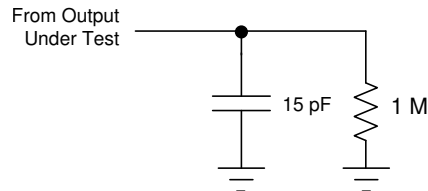

- A. The outputs are measured one at a time, with one transition per measurement.

Figure 7-1. Load Circuit For Maximum Data Rate: Pulse Duration, Propagation Delay Output Rise, And Fall Time Measurement

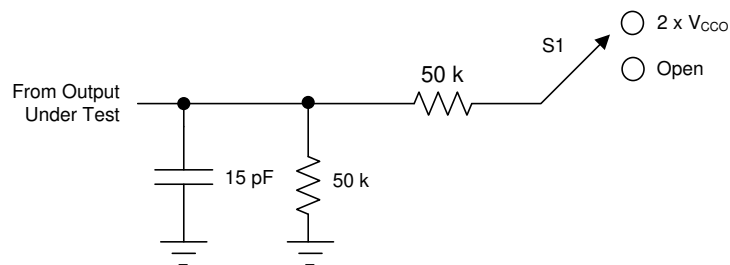

- A. The outputs are measured one at a time, with one transition per measurement.

Figure 7-2. Load Circuit For Enable and Disable Time Measurement

Table 7-1. Switch Position For Enable and Disable Time Measurement (See Figure 7-2)

TEST	S1
t_{PZL}, t_{PLZ}	$2 \times V_{CC0}$
t_{PHZ}, t_{PZH}	Open

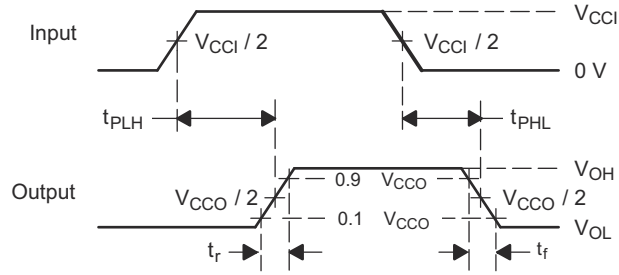

- A. V_{CCI} is the V_{CC} associated with the input port.
- B. V_{CCO} is the V_{CC} associated with the output port.
- C. t_{PLH} and t_{PHL} are the same as t_{pd} .
- D. The outputs are measured one at a time, with one transition per measurement.

Figure 7-3. Voltage Waveforms Propagation Delay Times

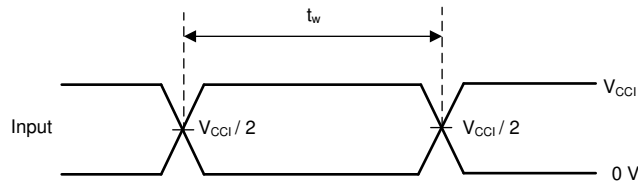

Figure 7-4. Voltage Waveforms Pulse Duration

8 Detailed Description

8.1 Overview

The TXB0104 device is a 4-bit, directionless voltage-level translator specifically designed for translating logic voltage levels. The A port is able to accept I/O voltages ranging from 1.2 V to 3.6 V, while the B port can accept I/O voltages from 1.65 V to 5.5 V. The device is a buffered architecture with edge-rate accelerators (one-shots) to improve the overall data rate. This device can only translate push-pull CMOS logic outputs. If for open-drain signal translation, please refer to TI's TXS010X products.

8.2 Functional Block Diagram

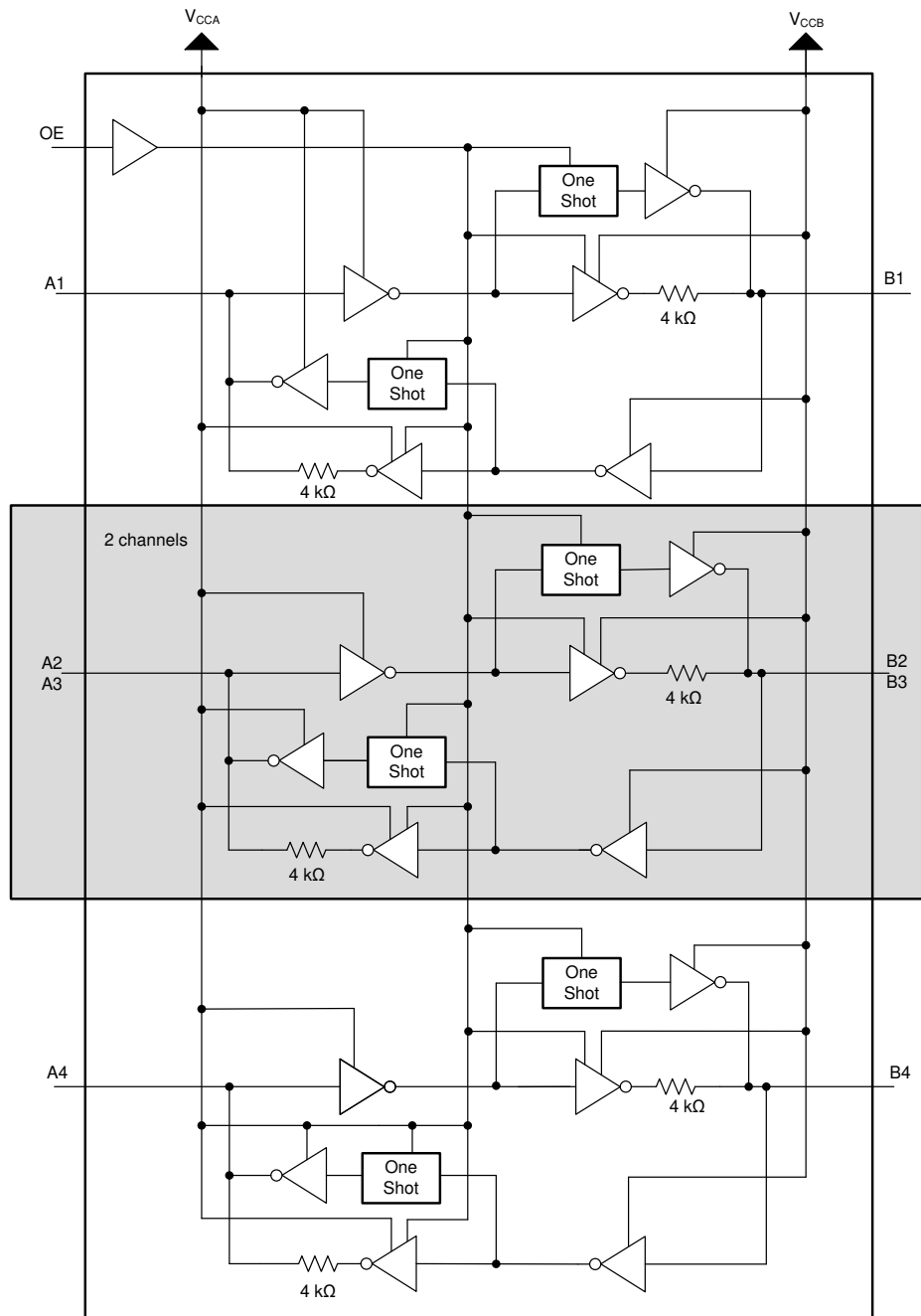

8.3 Feature Description

8.3.1 Architecture

The TXB0104 device architecture (see [Figure 8-1](#)) does not require a direction-control signal to control the direction of data flow from A to B or from B to A. In a DC state, the output drivers of the device maintain a high or low, but are designed to be weak, so the output drivers can be overdriven by an external driver when data on the bus flows the opposite direction.

The output one-shots detect rising or falling edges on the A or B ports. During a rising edge, the one-shot turns on the PMOS transistors (T1, T3) for a short duration, which speeds up the low-to-high transition. Similarly, during a falling edge, the one-shot turns on the NMOS transistors (T2, T4) for a short duration, which speeds up the high-to-low transition. The typical output impedance during output transition is 70 Ω at $V_{CCO} = 1.2\text{ V to }1.8\text{ V}$, 50 Ω at $V_{CCO} = 1.8\text{ V to }3.3\text{ V}$, and 40 Ω at $V_{CCO} = 3.3\text{ V to }5\text{ V}$.

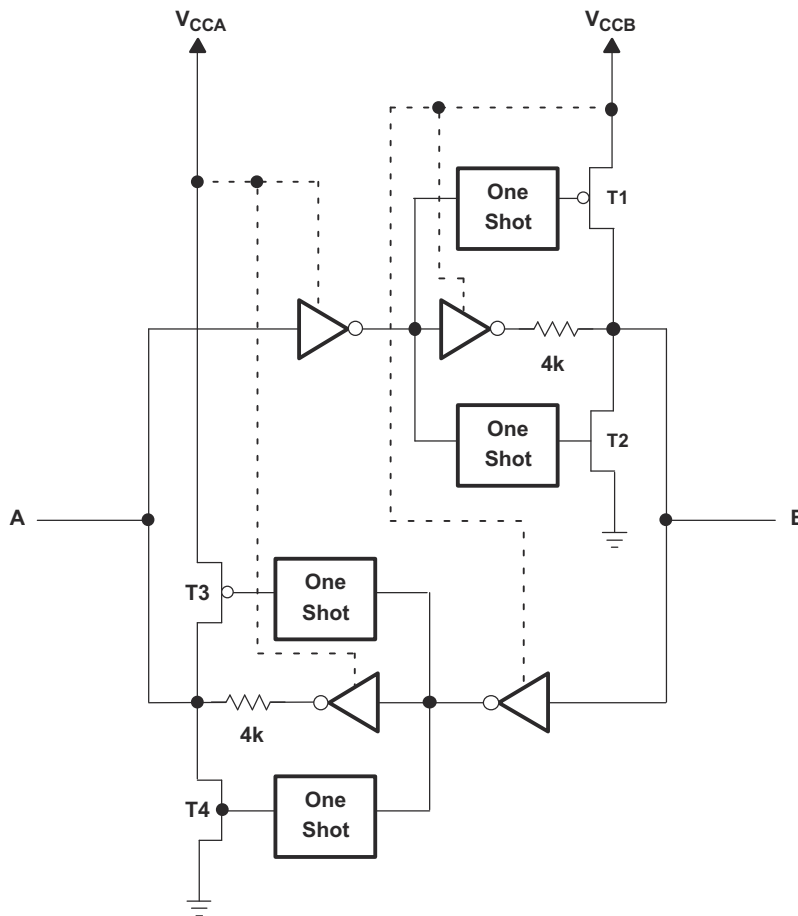
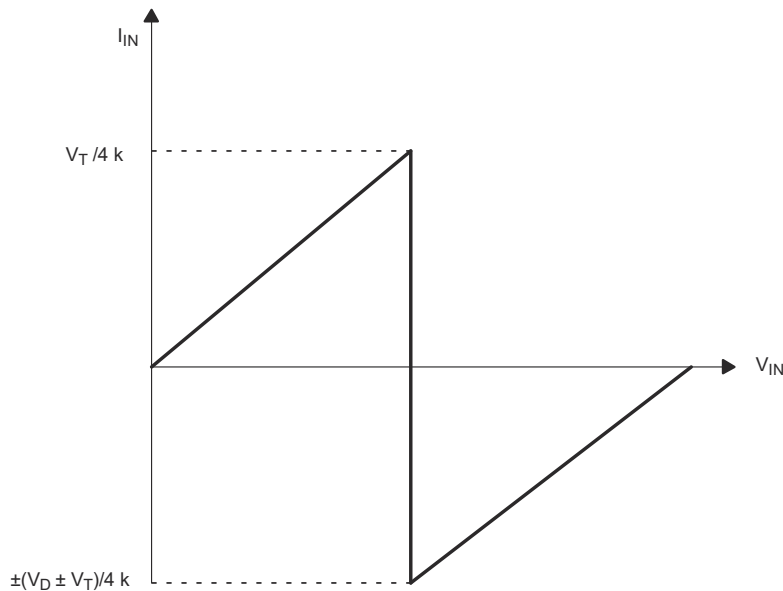

Figure 8-1. Architecture of TXB0104 Device I/O Cell

8.3.2 Input Driver Requirements

Typical I_{IN} vs V_{IN} characteristics of the device are shown in Figure 8-2. For proper operation, the device driving the data I/Os of the TXB0104 device must have drive strength of at least ± 2 mA.



- A. V_T is the input threshold of the TXB0104 device, (typically $V_{CC} / 2$).
- B. V_D is the supply voltage of the external driver.

Figure 8-2. Typical I_{IN} vs V_{IN} Curve

8.3.3 Output Load Considerations

TI recommends careful PCB layout practices with short PCB trace lengths to avoid excessive capacitive loading and to ensure that proper O.S. triggering takes place. PCB signal trace-lengths must be kept short enough such that the round trip delay of any reflection is less than the one-shot duration. This improves signal integrity by ensuring that any reflection sees a low impedance at the driver. The O.S. circuits have been designed to stay on for approximately 10 ns. The maximum capacitance of the lumped load that can be driven also depends directly on the one-shot duration. With very heavy capacitive loads, the one-shot can time-out before the signal is driven fully to the positive rail. The O.S. duration has been set to best optimize trade-offs between dynamic ICC, load driving capability, and maximum bit-rate considerations. Both PCB trace length and connectors add to the capacitance that the device output sees, so it is recommended that this lumped-load capacitance be considered to avoid O.S. retriggering, bus contention, output signal oscillations, or other adverse system-level affects.

8.3.4 Enable and Disable

The TXB0104 device has an OE input that is used to disable the device by setting OE = low, which places all I/Os in the high-impedance (Hi-Z) state. The disable time (t_{dis}) indicates the delay between when OE goes low and when the outputs actually get disabled (Hi-Z). The enable time (t_{en}) indicates the amount of time the user must allow for the one-shot circuitry to become operational after OE is taken high.

8.3.5 Pullup or Pulldown Resistors on I/O Lines

The device is designed to drive capacitive loads of up to 70 pF. The output drivers of the TXB0104 device have low dc drive strength. If pullup or pulldown resistors are connected externally to the data I/Os, their values must be kept higher than 50 k Ω to ensure that they do not contend with the output drivers of the TXB0104 device.

For the same reason, the TXB0104 device must not be used in applications such as I²C or 1-Wire where an open-drain driver is connected on the bidirectional data I/O. For these applications, use a device from the TI TXS01xx series of level translators.

8.4 Device Functional Modes

The device has two functional modes, enabled and disabled. To disable the device, set the OE input to low, which places all I/Os in a high impedance state. Setting the OE input to high will enable the device.

9 Application and Implementation

Note

Information in the following applications sections is not part of the TI component specification, and TI does not warrant its accuracy or completeness. TI's customers are responsible for determining suitability of components for their purposes, as well as validating and testing their design implementation to confirm system functionality.

9.1 Application Information

The TXB0104 device can be used in level-translation applications for interfacing devices or systems operating at different interface voltages with one another. It can only translate push-pull CMOS logic outputs. If for open-drain signal translation, please refer to TI TXS010X products. Any external pulldown or pullup resistors are recommended larger than 50 k Ω .

9.2 Typical Application

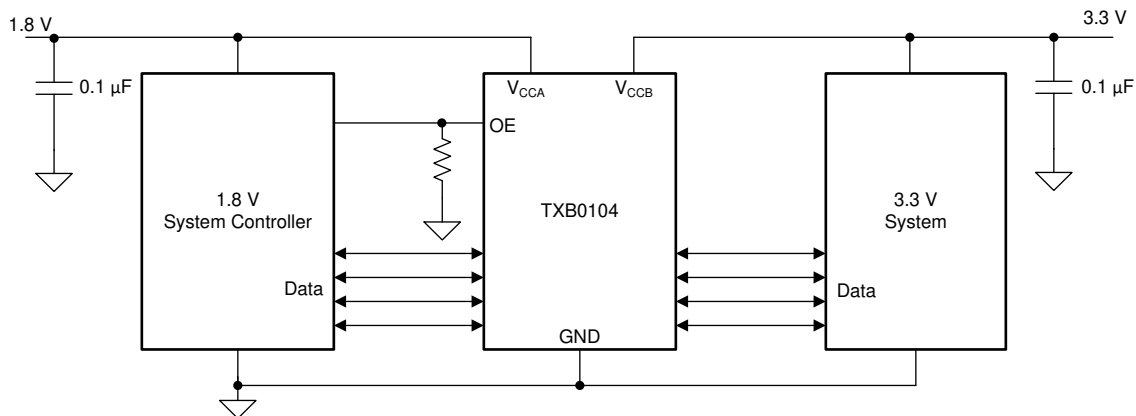

9.2.1 Design Requirements

For this design example, use the parameters listed in [Table 9-1](#). And make sure the $V_{CCA} \leq V_{CCB}$.

Table 9-1. Design Parameters

DESIGN PARAMETERS	EXAMPLE VALUE
Input voltage range	1.2 V to 3.6 V
Output voltage range	1.65 V to 5.5 V

9.2.2 Detailed Design Procedure

To begin the design process, determine the following:

- Input voltage range
 - Use the supply voltage of the device that is driving the TXB0104 device to determine the input voltage range. For a valid logic high, the value must exceed the V_{IH} of the input port. For a valid logic low, the value must be less than the V_{IL} of the input port.
- Output voltage range
 - Use the supply voltage of the device that the device is driving to determine the output voltage range.
 - External pullup or pulldown resistors are not recommended. If mandatory, it is recommended that the value must be larger than 50 k Ω .
 - An external pulldown or pullup resistor decreases the output V_{OH} and V_{OL} . Use the below equations to draft estimate the V_{OH} and V_{OL} as a result of an external pulldown and pullup resistor.

$$V_{OH} = V_{CCx} \times R_{PD} / (R_{PD} + 4.5 \text{ k}\Omega)$$

$$V_{OL} = V_{CCx} \times 4.5 \text{ k}\Omega / (R_{PU} + 4.5 \text{ k}\Omega)$$

Where

- V_{CCx} is the output port supply voltage on either V_{CCA} or V_{CCB}
- R_{PD} is the value of the external pull down resistor
- R_{PU} is the value of the external pull up resistor
- 4.5 k Ω is the counting the variation of the serial resistor 4 k Ω in the I/O line.

9.2.3 Application Curves

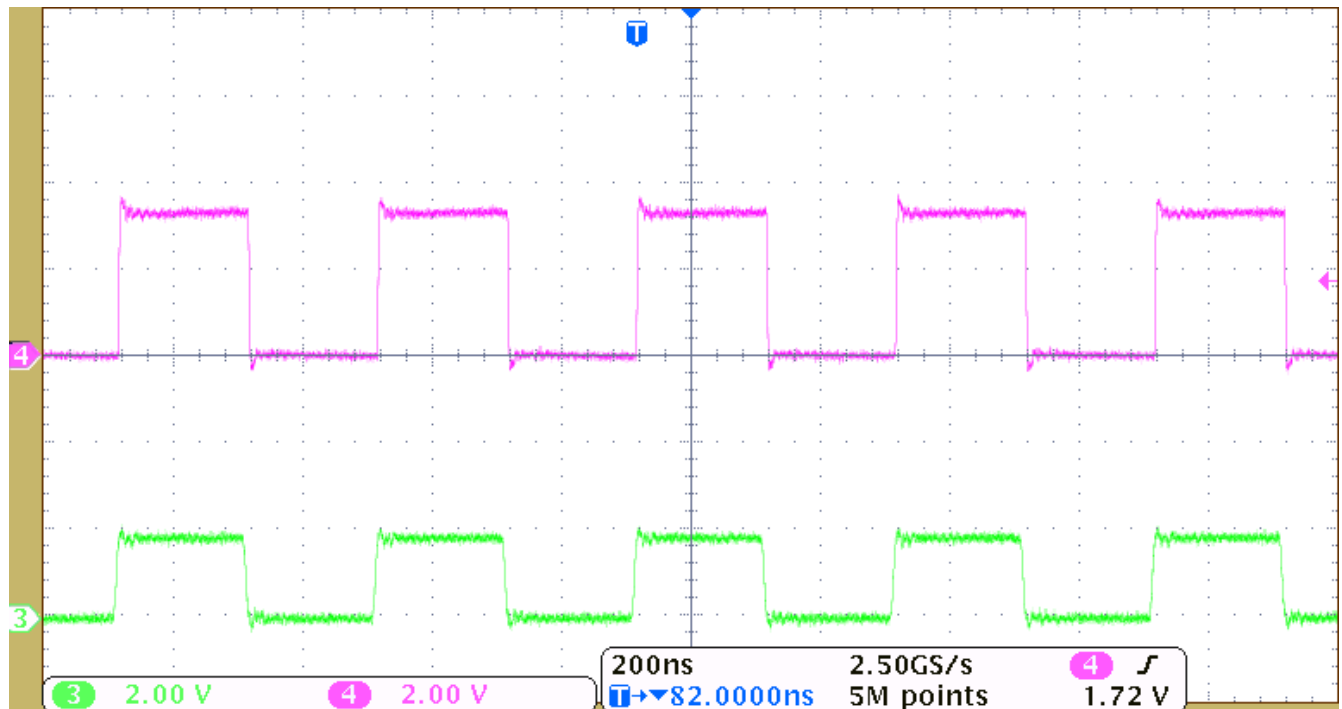

Figure 9-1. Level-Translation of a 2.5-MHz Signal

10 Power Supply Recommendations

During operation, ensure that $V_{CCA} \leq V_{CCB}$ at all times. During power-up sequencing, $V_{CCA} \geq V_{CCB}$ does not damage the device, so any power supply can be ramped up first. The device has circuitry that disables all output ports when either V_{CC} is switched off ($V_{CCA/B} = 0\text{ V}$). The output-enable (OE) input circuit is designed so that it is supplied by V_{CCA} and when the (OE) input is low, all outputs are placed in the high-impedance state. To ensure the high-impedance state of the outputs during power up or power down, the OE input pin must be tied to GND through a pulldown resistor and must not be enabled until V_{CCA} and V_{CCB} are fully ramped and stable. The minimum value of the pulldown resistor to ground is determined by the current-sourcing capability of the driver.

11 Layout

11.1 Layout Guidelines

To ensure reliability of the device, following common printed-circuit board layout guidelines is recommended.

- Bypass capacitors must be used on power supplies, and must be placed as close as possible to the V_{CCA} , V_{CCB} pin and GND pin.
- Short trace-lengths must be used to avoid excessive loading.
- PCB signal trace-lengths must be kept short enough so that the round-trip delay of any reflection is less than the one-shot duration, approximately 10 ns, ensuring that any reflection encounters low impedance at the source driver.

11.2 Layout Example

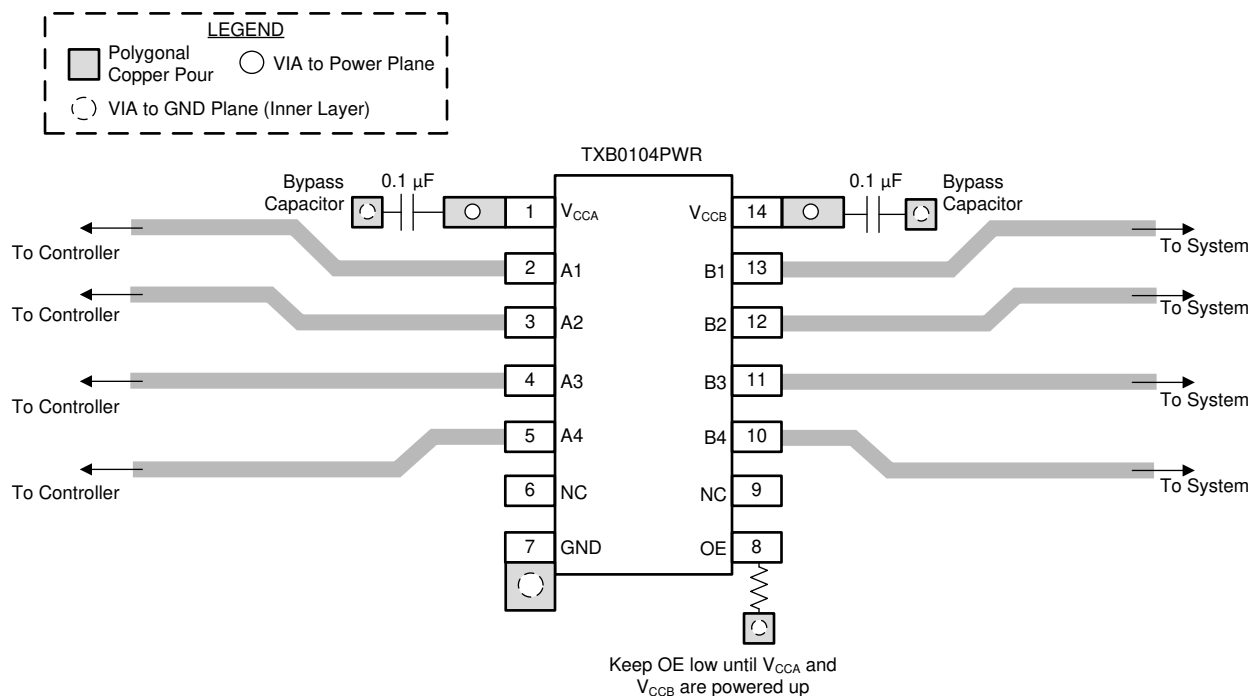

12 Device and Documentation Support

12.1 Receiving Notification of Documentation Updates

To receive notification of documentation updates, navigate to the device product folder on ti.com. Click on *Subscribe to updates* to register and receive a weekly digest of any product information that has changed. For change details, review the revision history included in any revised document.

12.2 Support Resources

[TI E2E™ support forums](#) are an engineer's go-to source for fast, verified answers and design help — straight from the experts. Search existing answers or ask your own question to get the quick design help you need.

Linked content is provided "AS IS" by the respective contributors. They do not constitute TI specifications and do not necessarily reflect TI's views; see TI's [Terms of Use](#).

12.3 Trademarks

BGA MICROSTAR JUNIOR™ is a trademark of Texas Instruments.

TI E2E™ is a trademark of Texas Instruments.

All trademarks are the property of their respective owners.

12.4 Electrostatic Discharge Caution



This integrated circuit can be damaged by ESD. Texas Instruments recommends that all integrated circuits be handled with appropriate precautions. Failure to observe proper handling and installation procedures can cause damage.

ESD damage can range from subtle performance degradation to complete device failure. Precision integrated circuits may be more susceptible to damage because very small parametric changes could cause the device not to meet its published specifications.

12.5 Glossary

[TI Glossary](#) This glossary lists and explains terms, acronyms, and definitions.

13 Mechanical, Packaging, and Orderable Information

The following pages include mechanical, packaging, and orderable information. This information is the most current data available for the designated devices. This data is subject to change without notice and revision of this document. For browser-based versions of this data sheet, refer to the left-hand navigation.

MECHANICAL DATA

YZT (R-XBGA-N12)

(CUSTOM) DIE-SIZE BALL GRID ARRAY

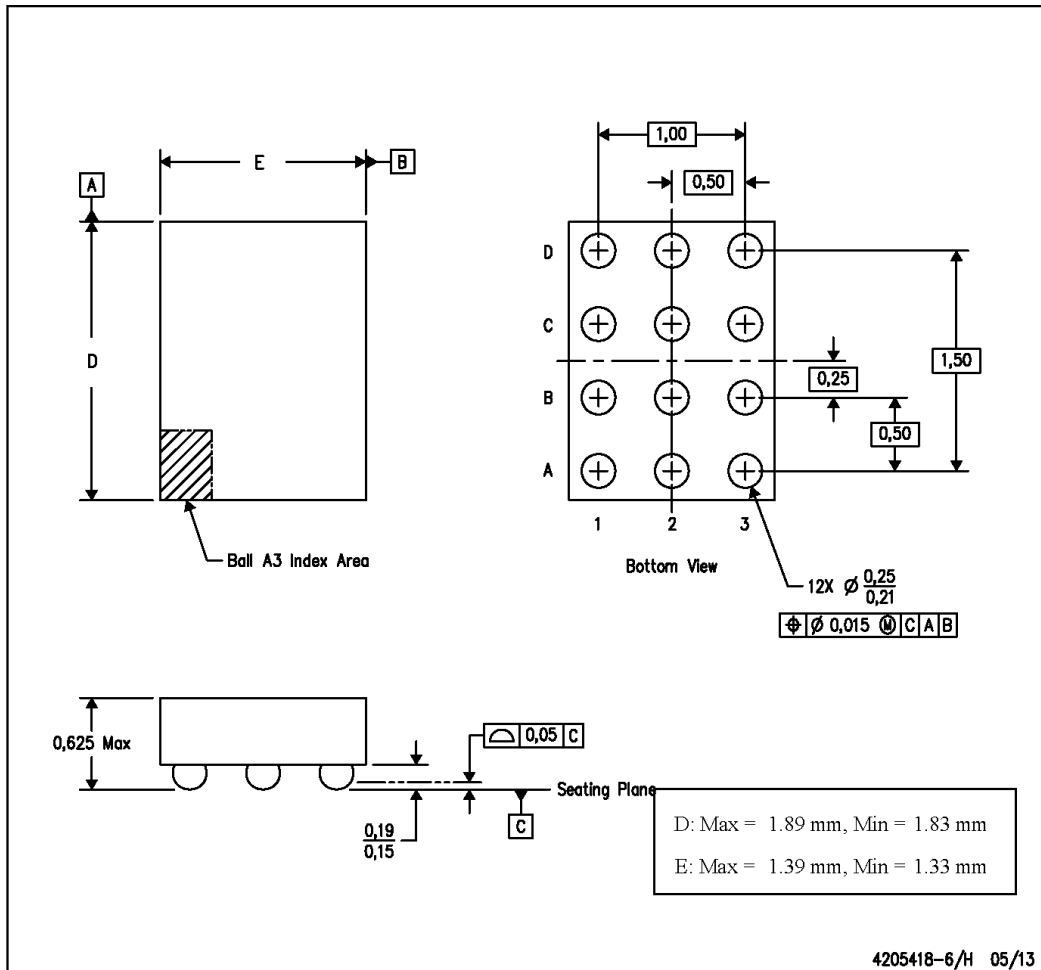

- NOTES:
- A. All linear dimensions are in millimeters. Dimensioning and tolerancing per ASME Y14.5M-1994.
 - B. This drawing is subject to change without notice.
 - C. NanoFree™ package configuration.

NanoFree is a trademark of Texas Instruments.

PACKAGING INFORMATION

Orderable Device	Status (1)	Package Type	Package Drawing	Pins	Package Qty	Eco Plan (2)	Lead finish/ Ball material (6)	MSL Peak Temp (3)	Op Temp (°C)	Device Marking (4/5)	Samples
TXB0104D	ACTIVE	SOIC	D	14	50	RoHS & Green	NIPDAU	Level-1-260C-UNLIM	-40 to 85	TXB0104	Samples
TXB0104DG4	ACTIVE	SOIC	D	14	50	RoHS & Green	NIPDAU	Level-1-260C-UNLIM	-40 to 85	TXB0104	Samples
TXB0104DR	ACTIVE	SOIC	D	14	2500	RoHS & Green	NIPDAU	Level-1-260C-UNLIM	-40 to 85	TXB0104	Samples
TXB0104DRG4	ACTIVE	SOIC	D	14	2500	RoHS & Green	NIPDAU	Level-1-260C-UNLIM	-40 to 85	TXB0104	Samples
TXB0104NMNR	ACTIVE	NFBGA	NMN	12	2500	RoHS & Green	SNAGCU	Level-2-260C-1 YEAR	-40 to 85	2AQW	Samples
TXB0104PWR	ACTIVE	TSSOP	PW	14	2000	RoHS & Green	NIPDAU	Level-1-260C-UNLIM	-40 to 85	YE04	Samples
TXB0104PWRG4	ACTIVE	TSSOP	PW	14	2000	RoHS & Green	NIPDAU	Level-1-260C-UNLIM	-40 to 85	YE04	Samples
TXB0104RGYR	ACTIVE	VQFN	RGY	14	3000	RoHS & Green	NIPDAU	Level-2-260C-1 YEAR	-40 to 85	YE04	Samples
TXB0104RGYRG4	ACTIVE	VQFN	RGY	14	3000	RoHS & Green	NIPDAU	Level-2-260C-1 YEAR	-40 to 85	YE04	Samples
TXB0104RUTR	ACTIVE	UQFN	RUT	12	3000	RoHS & Green	NIPDAUAG	Level-1-260C-UNLIM	-40 to 85	(2KR, 2KV)	Samples
TXB0104YZTR	ACTIVE	DSBGA	YZT	12	3000	RoHS & Green	SNAGCU	Level-1-260C-UNLIM	-40 to 85	2K	Samples

(1) The marketing status values are defined as follows:

ACTIVE: Product device recommended for new designs.

LIFEBUY: TI has announced that the device will be discontinued, and a lifetime-buy period is in effect.

NRND: Not recommended for new designs. Device is in production to support existing customers, but TI does not recommend using this part in a new design.

PREVIEW: Device has been announced but is not in production. Samples may or may not be available.

OBSELETE: TI has discontinued the production of the device.

(2) **RoHS:** TI defines "RoHS" to mean semiconductor products that are compliant with the current EU RoHS requirements for all 10 RoHS substances, including the requirement that RoHS substance do not exceed 0.1% by weight in homogeneous materials. Where designed to be soldered at high temperatures, "RoHS" products are suitable for use in specified lead-free processes. TI may reference these types of products as "Pb-Free".

RoHS Exempt: TI defines "RoHS Exempt" to mean products that contain lead but are compliant with EU RoHS pursuant to a specific EU RoHS exemption.

Green: TI defines "Green" to mean the content of Chlorine (Cl) and Bromine (Br) based flame retardants meet JS709B low halogen requirements of <=1000ppm threshold. Antimony trioxide based flame retardants must also meet the <=1000ppm threshold requirement.

(3) MSL, Peak Temp. - The Moisture Sensitivity Level rating according to the JEDEC industry standard classifications, and peak solder temperature.

(4) There may be additional marking, which relates to the logo, the lot trace code information, or the environmental category on the device.

(5) Multiple Device Markings will be inside parentheses. Only one Device Marking contained in parentheses and separated by a "~" will appear on a device. If a line is indented then it is a continuation of the previous line and the two combined represent the entire Device Marking for that device.

(6) Lead finish/Ball material - Orderable Devices may have multiple material finish options. Finish options are separated by a vertical ruled line. Lead finish/Ball material values may wrap to two lines if the finish value exceeds the maximum column width.

Important Information and Disclaimer:The information provided on this page represents TI's knowledge and belief as of the date that it is provided. TI bases its knowledge and belief on information provided by third parties, and makes no representation or warranty as to the accuracy of such information. Efforts are underway to better integrate information from third parties. TI has taken and continues to take reasonable steps to provide representative and accurate information but may not have conducted destructive testing or chemical analysis on incoming materials and chemicals. TI and TI suppliers consider certain information to be proprietary, and thus CAS numbers and other limited information may not be available for release.

In no event shall TI's liability arising out of such information exceed the total purchase price of the TI part(s) at issue in this document sold by TI to Customer on an annual basis.

OTHER QUALIFIED VERSIONS OF TXB0104 :

- Automotive : [TXB0104-Q1](#)

NOTE: Qualified Version Definitions:

- Automotive - Q100 devices qualified for high-reliability automotive applications targeting zero defects

TAPE AND REEL INFORMATION

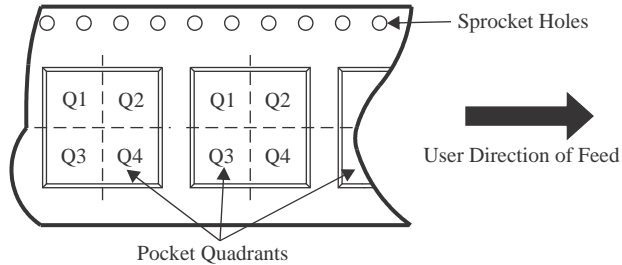
QUADRANT ASSIGNMENTS FOR PIN 1 ORIENTATION IN TAPE

*All dimensions are nominal

Device	Package Type	Package Drawing	Pins	SPQ	Reel Diameter (mm)	Reel Width W1 (mm)	A0 (mm)	B0 (mm)	K0 (mm)	P1 (mm)	W (mm)	Pin1 Quadrant
TXB0104DR	SOIC	D	14	2500	330.0	16.4	6.5	9.0	2.1	8.0	16.0	Q1
TXB0104NMNR	NFBGA	NMN	12	2500	180.0	8.4	2.3	2.8	1.15	4.0	8.0	Q2
TXB0104PWR	TSSOP	PW	14	2000	330.0	12.4	6.9	5.6	1.6	8.0	12.0	Q1
TXB0104RGYR	VQFN	RGY	14	3000	330.0	12.4	3.75	3.75	1.15	8.0	12.0	Q1
TXB0104RUTR	UQFN	RUT	12	3000	180.0	8.4	1.95	2.3	0.75	4.0	8.0	Q1
TXB0104RUTR	UQFN	RUT	12	3000	180.0	9.5	1.9	2.2	0.7	4.0	8.0	Q1
TXB0104YZTR	DSBGA	YZT	12	3000	180.0	8.4	1.49	1.99	0.75	4.0	8.0	Q2

TAPE AND REEL BOX DIMENSIONS

*All dimensions are nominal

Device	Package Type	Package Drawing	Pins	SPQ	Length (mm)	Width (mm)	Height (mm)
TXB0104DR	SOIC	D	14	2500	356.0	356.0	35.0
TXB0104NMNR	NFBGA	NMN	12	2500	210.0	185.0	35.0
TXB0104PWR	TSSOP	PW	14	2000	356.0	356.0	35.0
TXB0104RGYR	VQFN	RGY	14	3000	356.0	356.0	35.0
TXB0104RUTR	UQFN	RUT	12	3000	202.0	201.0	28.0
TXB0104RUTR	UQFN	RUT	12	3000	189.0	185.0	36.0
TXB0104YZTR	DSBGA	YZT	12	3000	182.0	182.0	20.0

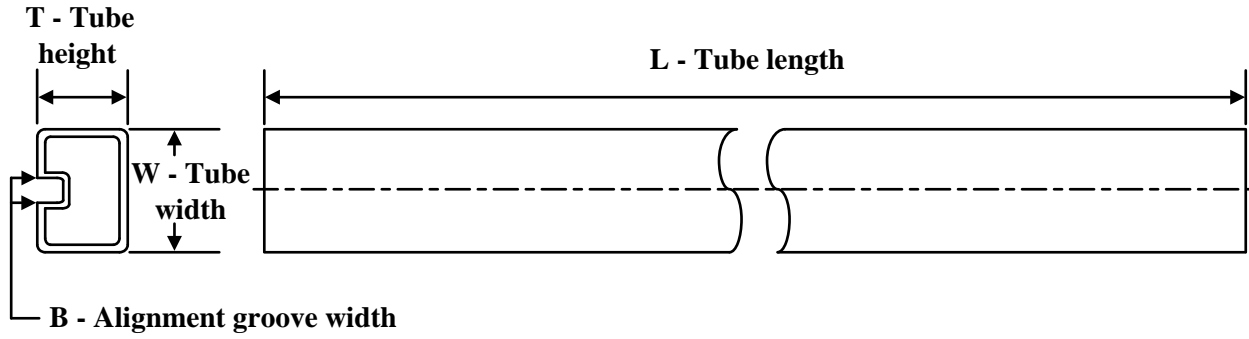
TUBE

*All dimensions are nominal

Device	Package Name	Package Type	Pins	SPQ	L (mm)	W (mm)	T (μm)	B (mm)
TXB0104D	D	SOIC	14	50	506.6	8	3940	4.32
TXB0104DG4	D	SOIC	14	50	506.6	8	3940	4.32

MECHANICAL DATA

YZT (R-XBGA-N12)

(CUSTOM) DIE-SIZE BALL GRID ARRAY

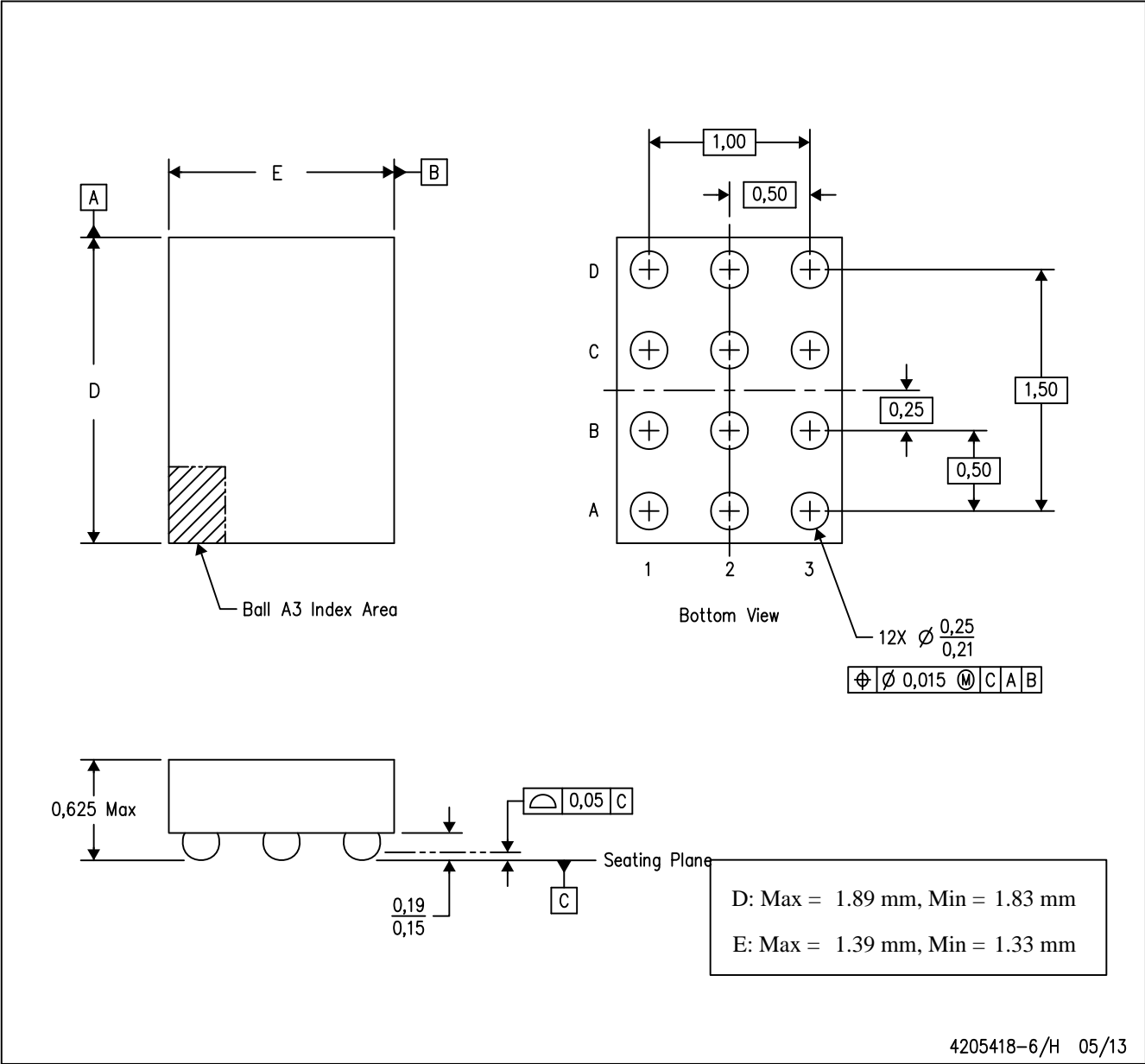

- NOTES:
- A. All linear dimensions are in millimeters. Dimensioning and tolerancing per ASME Y14.5M-1994.
 - B. This drawing is subject to change without notice.
 - C. NanoFree™ package configuration.

NanoFree is a trademark of Texas Instruments.

RGY (S-PVQFN-N14)

PLASTIC QUAD FLATPACK NO-LEAD

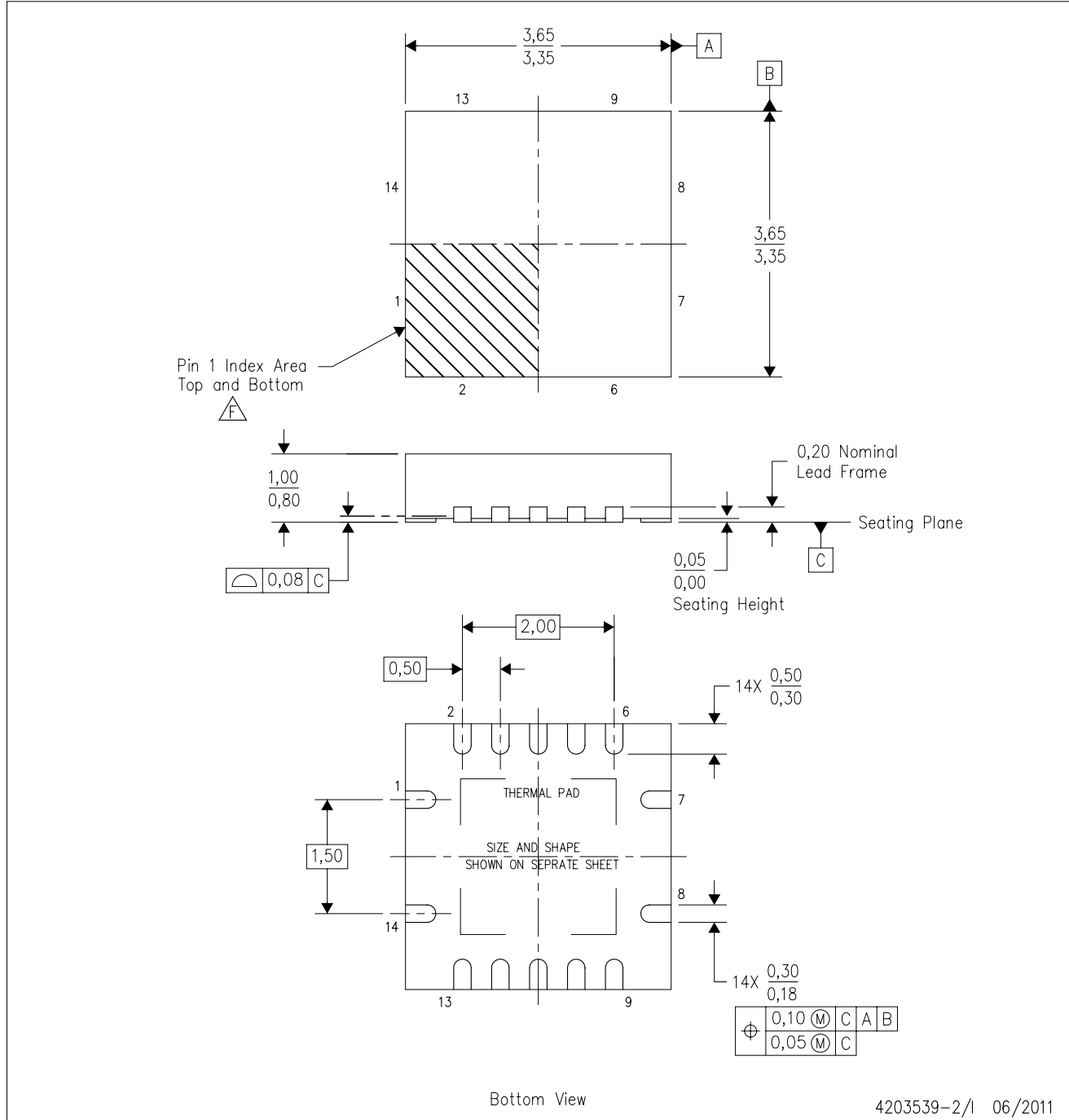

- NOTES:
- A. All linear dimensions are in millimeters. Dimensioning and tolerancing per ASME Y14.5M-1994.
 - B. This drawing is subject to change without notice.
 - C. QFN (Quad Flatpack No-Lead) package configuration.
 - D. The package thermal pad must be soldered to the board for thermal and mechanical performance.
 - E. See the additional figure in the Product Data Sheet for details regarding the exposed thermal pad features and dimensions.
 - $\triangle F$ Pin 1 identifiers are located on both top and bottom of the package and within the zone indicated. The Pin 1 identifiers are either a molded, marked, or metal feature.
 - G. Package complies to JEDEC MO-241 variation BA.

RGY (S-PVQFN-N14)

PLASTIC QUAD FLATPACK NO-LEAD

THERMAL INFORMATION

This package incorporates an exposed thermal pad that is designed to be attached directly to an external heatsink. The thermal pad must be soldered directly to the printed circuit board (PCB). After soldering, the PCB can be used as a heatsink. In addition, through the use of thermal vias, the thermal pad can be attached directly to the appropriate copper plane shown in the electrical schematic for the device, or alternatively, can be attached to a special heatsink structure designed into the PCB. This design optimizes the heat transfer from the integrated circuit (IC).

For information on the Quad Flatpack No-Lead (QFN) package and its advantages, refer to Application Report, QFN/SON PCB Attachment, Texas Instruments Literature No. SLUA271. This document is available at www.ti.com.

The exposed thermal pad dimensions for this package are shown in the following illustration.

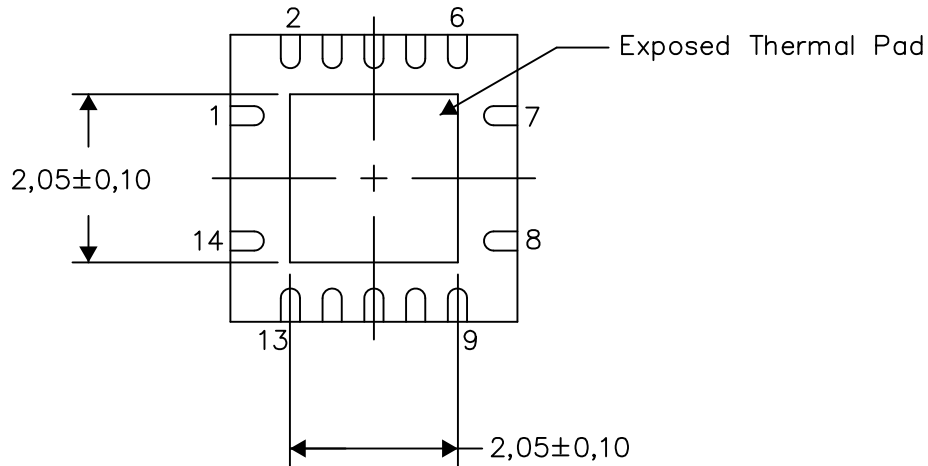

Bottom View

Exposed Thermal Pad Dimensions

4206353-2/P 03/14

NOTE: All linear dimensions are in millimeters

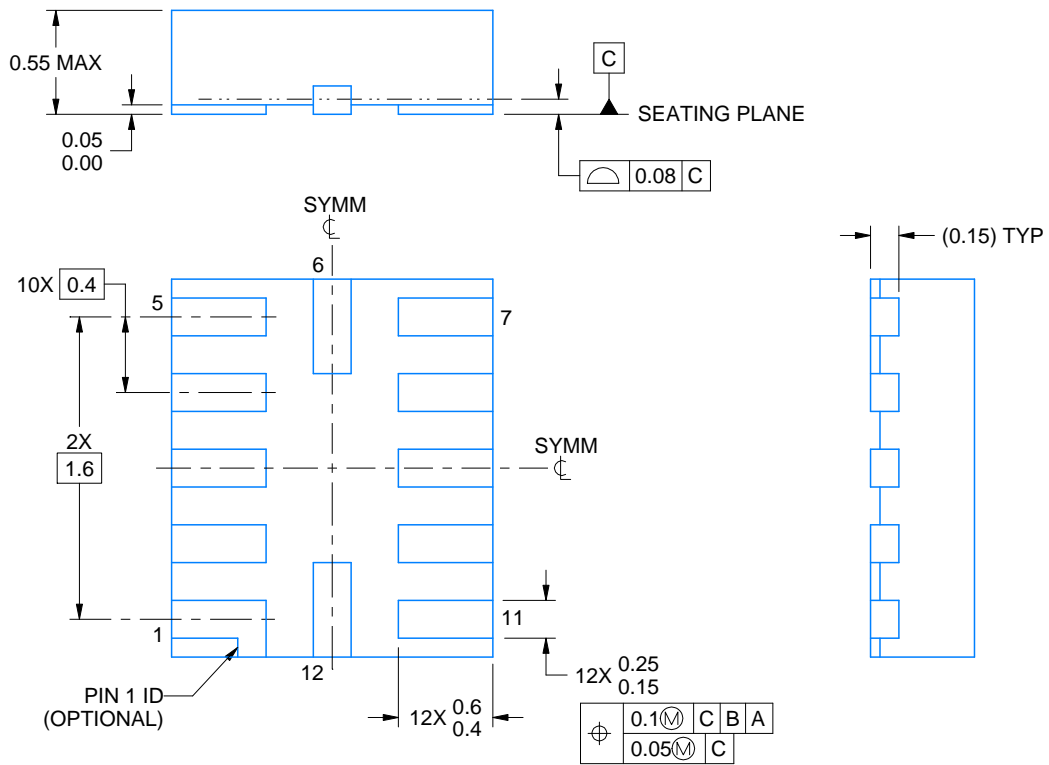
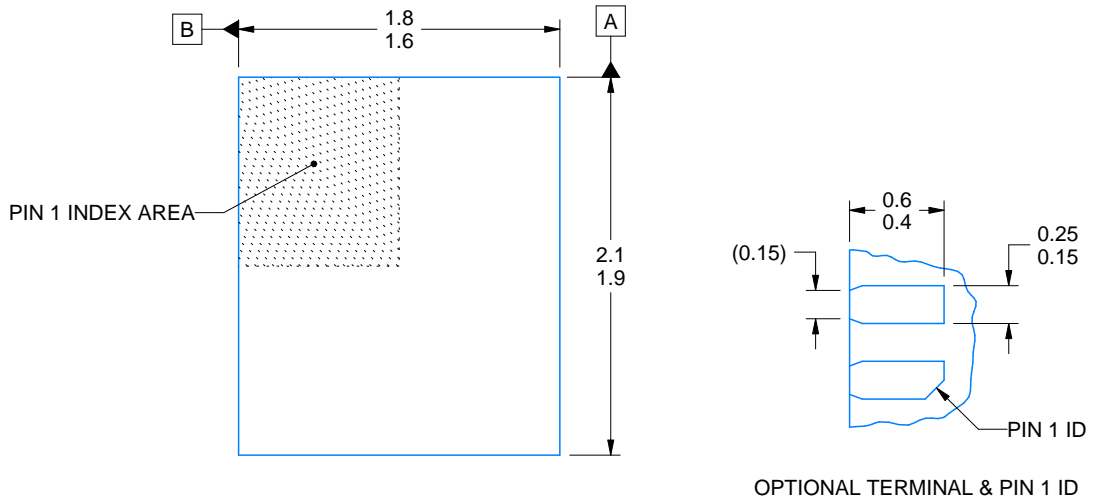
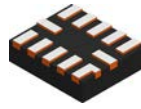

4220310/A 11/2016

NOTES:

1. All linear dimensions are in millimeters. Any dimensions in parenthesis are for reference only. Dimensioning and tolerancing per ASME Y14.5M.
2. This drawing is subject to change without notice.

EXAMPLE BOARD LAYOUT

RUT0012A

UQFN - 0.55 mm max height

PLASTIC QUAD FLATPACK - NO LEAD

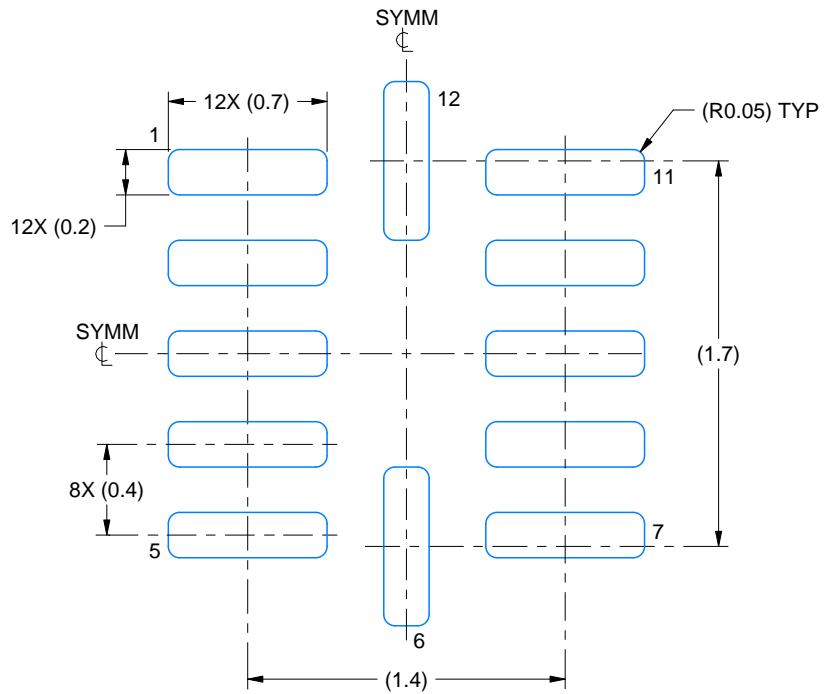

LAND PATTERN EXAMPLE
SCALE:30X

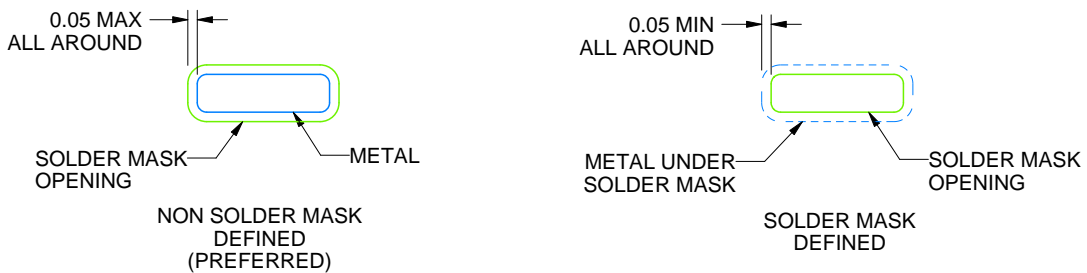

SOLDER MASK DETAILS

4220310/A 11/2016

NOTES: (continued)

3. For more information, see Texas Instruments literature number SLUA271 (www.ti.com/lit/sluea271).

EXAMPLE STENCIL DESIGN

RUT0012A

UQFN - 0.55 mm max height

PLASTIC QUAD FLATPACK - NO LEAD

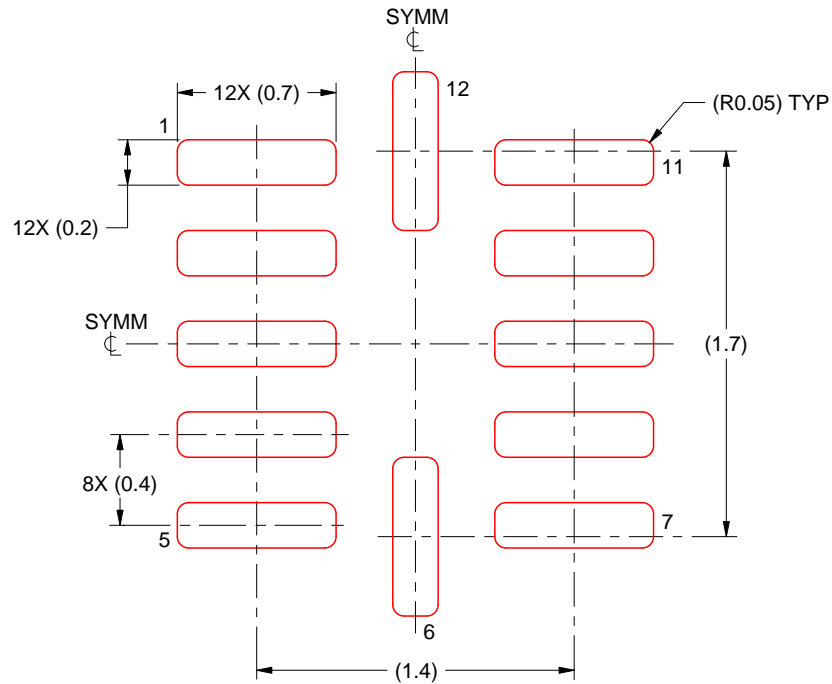

SOLDER PASTE EXAMPLE
BASED ON 0.1 mm THICK STENCIL
SCALE: 30X

4220310/A 11/2016

NOTES: (continued)

4. Laser cutting apertures with trapezoidal walls and rounded corners may offer better paste release. IPC-7525 may have alternate design recommendations.

D (R-PDSO-G14)

PLASTIC SMALL OUTLINE

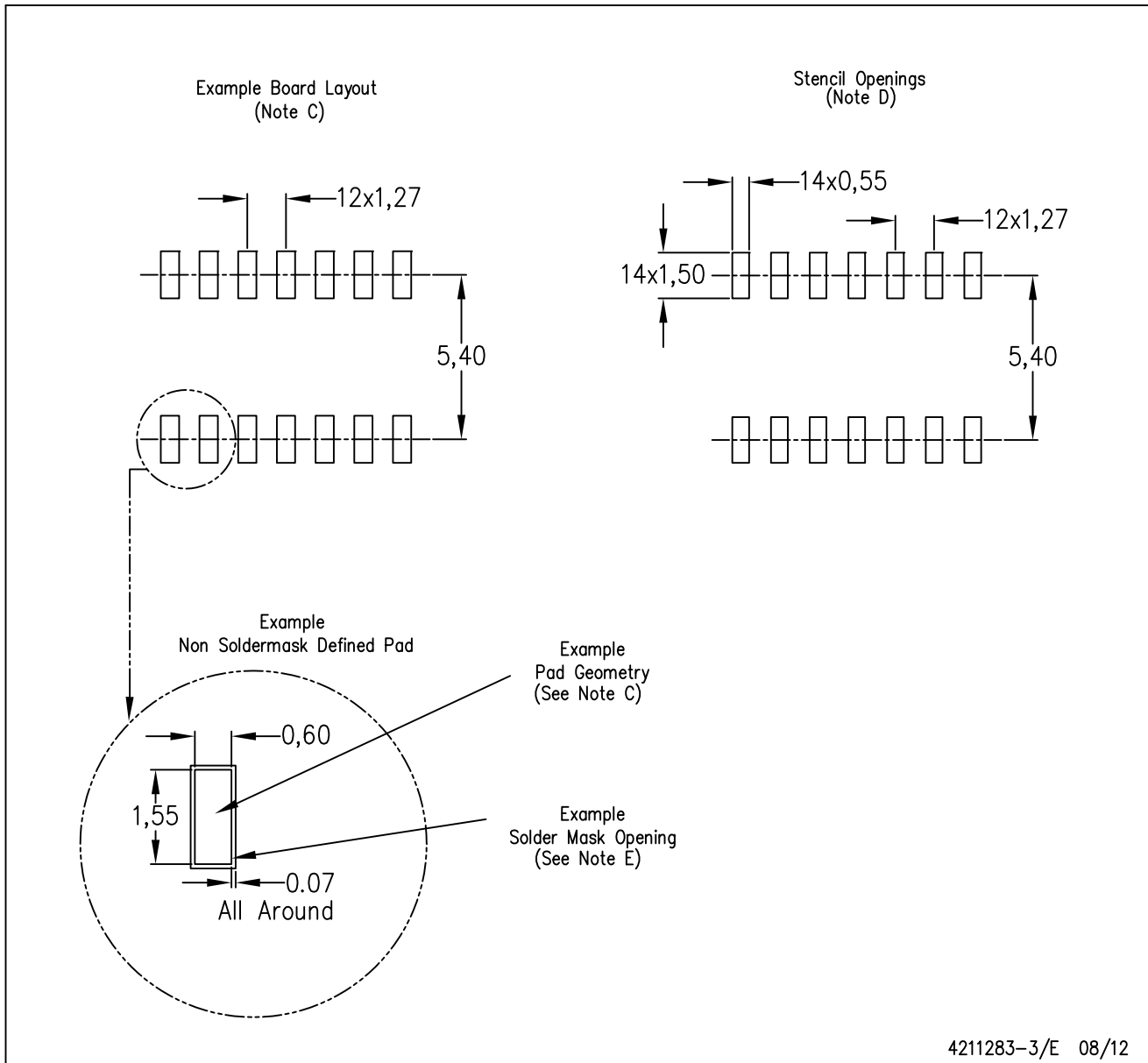

4211283-3/E 08/12

- NOTES:
- All linear dimensions are in millimeters.
 - This drawing is subject to change without notice.
 - Publication IPC-7351 is recommended for alternate designs.
 - Laser cutting apertures with trapezoidal walls and also rounding corners will offer better paste release. Customers should contact their board assembly site for stencil design recommendations. Refer to IPC-7525 for other stencil recommendations.
 - Customers should contact their board fabrication site for solder mask tolerances between and around signal pads.

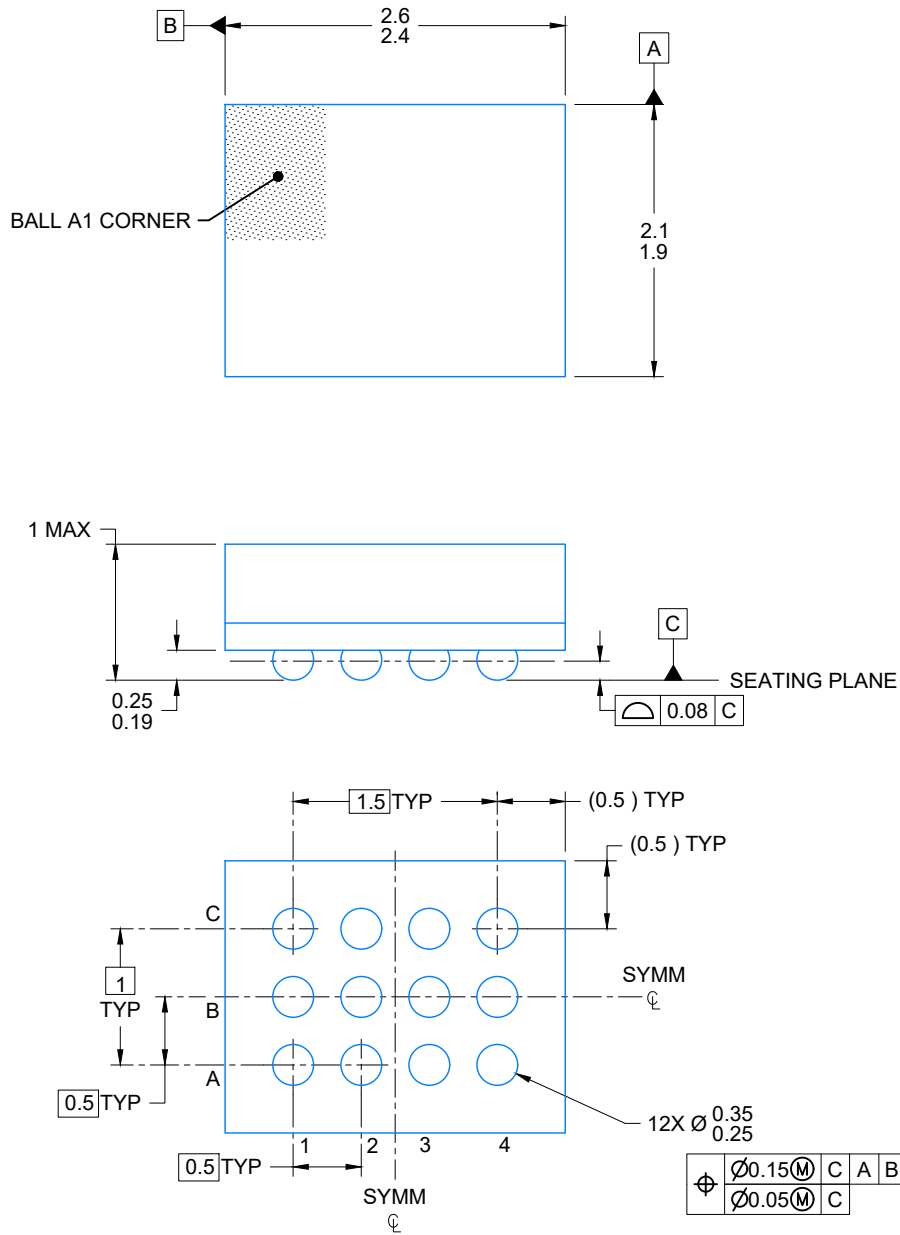

4225768/A 03/2020

NOTES:

NanoFree is a trademark of Texas Instruments.

1. All linear dimensions are in millimeters. Any dimensions in parenthesis are for reference only. Dimensioning and tolerancing per ASME Y14.5M.
2. This drawing is subject to change without notice.

EXAMPLE BOARD LAYOUT

NMN0012A

NFBGA - 1 mm max height

PLASTIC BALL GRID ARRAY

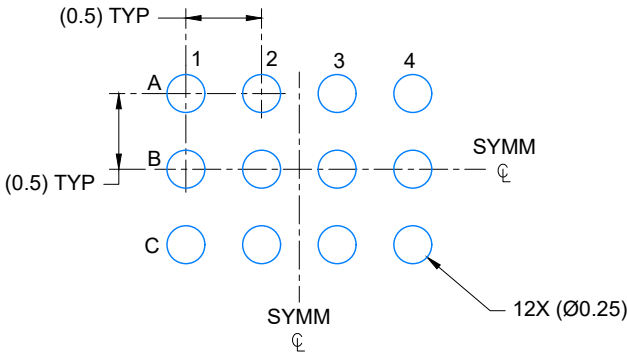

LAND PATTERN EXAMPLE
SCALE: 20X

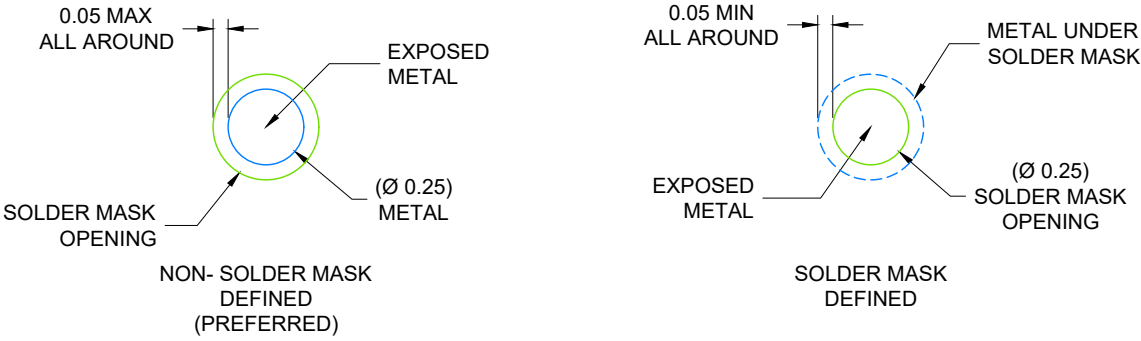

SOLDER MASK DETAILS
NOT TO SCALE

4225768/A 03/2020

NOTES: (continued)

- 3. Final dimensions may vary due to manufacturing tolerance considerations and also routing constraints. Refer to Texas Instruments Literature number SNVA009 (www.ti.com/lit/snva009).

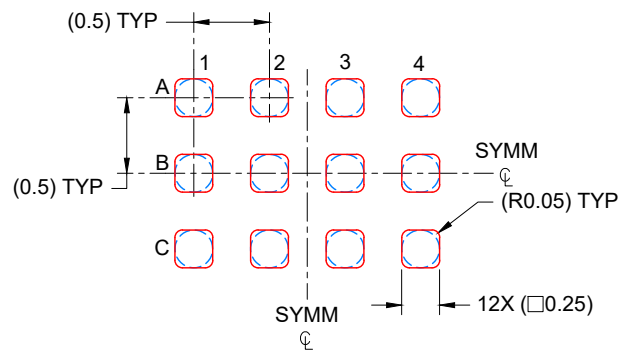

SOLDER PASTE EXAMPLE
 BASED ON 0.100 mm THICK STENCIL
 SCALE: 20X

4225768/A 03/2020

NOTES: (continued)

4. Laser cutting apertures with trapezoidal walls and rounded corners may offer better paste release.

IMPORTANT NOTICE AND DISCLAIMER

TI PROVIDES TECHNICAL AND RELIABILITY DATA (INCLUDING DATA SHEETS), DESIGN RESOURCES (INCLUDING REFERENCE DESIGNS), APPLICATION OR OTHER DESIGN ADVICE, WEB TOOLS, SAFETY INFORMATION, AND OTHER RESOURCES "AS IS" AND WITH ALL FAULTS, AND DISCLAIMS ALL WARRANTIES, EXPRESS AND IMPLIED, INCLUDING WITHOUT LIMITATION ANY IMPLIED WARRANTIES OF MERCHANTABILITY, FITNESS FOR A PARTICULAR PURPOSE OR NON-INFRINGEMENT OF THIRD PARTY INTELLECTUAL PROPERTY RIGHTS.

These resources are intended for skilled developers designing with TI products. You are solely responsible for (1) selecting the appropriate TI products for your application, (2) designing, validating and testing your application, and (3) ensuring your application meets applicable standards, and any other safety, security, regulatory or other requirements.

These resources are subject to change without notice. TI grants you permission to use these resources only for development of an application that uses the TI products described in the resource. Other reproduction and display of these resources is prohibited. No license is granted to any other TI intellectual property right or to any third party intellectual property right. TI disclaims responsibility for, and you will fully indemnify TI and its representatives against, any claims, damages, costs, losses, and liabilities arising out of your use of these resources.

TI's products are provided subject to [TI's Terms of Sale](#) or other applicable terms available either on [ti.com](https://www.ti.com) or provided in conjunction with such TI products. TI's provision of these resources does not expand or otherwise alter TI's applicable warranties or warranty disclaimers for TI products.

TI objects to and rejects any additional or different terms you may have proposed.

Mailing Address: Texas Instruments, Post Office Box 655303, Dallas, Texas 75265
Copyright © 2024, Texas Instruments Incorporated

Looking for pricing, stock, or lifecycle information?

Click below to explore more details on WIN SOURCE:

 [View TXB0104DR](#) on WIN SOURCE

 [Texas Instruments](#) Information

Optimize Your Supply Chain with WIN SOURCE Solutions

-  Global Sourcing Solution
-  Obsolete Management
-  Cost Control Management
-  Shortage Management
-  Alternative Solution
-  Excess Inventory Management