



THE DATASHEET OF TX1318T



FEATURES

- 5.0+ GHz Toggle Frequency
- 470ps Propagation Delay
- Internal Input Pull-down Resistors
- 3.0V to 5.5V Power Supply
- RoHS Compliant Pb Free Packages

BLOCK DIAGRAM

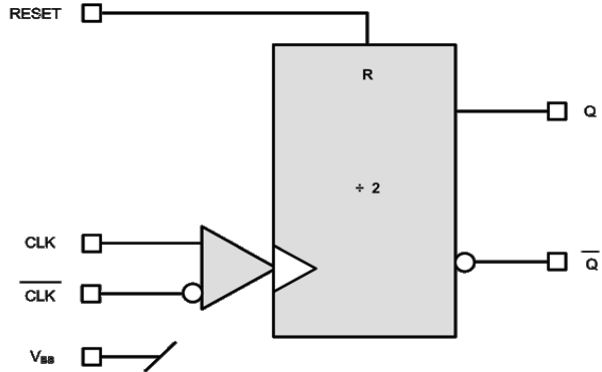

DESCRIPTION

The CTS100LVEL33 is an integrated ÷4 divider. The reset pin is asynchronous and is asserted on the rising edge. Upon power-up, the internal flip-flop will attain a random logic state; the reset allows for the synchronization of multiple CTS100LVEL33's in a system.

The CTS100LVEL33 is a direct replacement for the On Semiconductor MC100EL/LVEL33.

ENGINEERING NOTES

The CTS100LVEL33 provides a V_{BB} output for single-ended use or a DC bias reference for AC coupling to the device. For single-ended input applications, the V_{BB} reference should be connected to one side of the CLK/ \overline{CLK} differential input pair. The input signal is then fed to the other CLK/ \overline{CLK} input. The V_{BB} pin should be used only as a bias for the CTS100LVEL32 as its sink/source capability is limited. When used, the V_{BB} pin should be bypassed to ground via a 0.01 μ F capacitor.

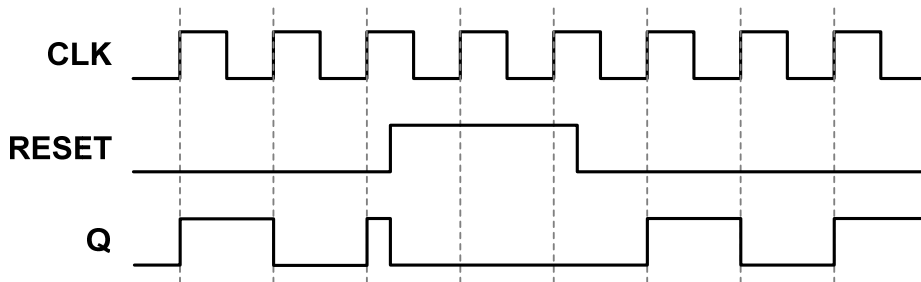

Figure 1 - Timing Diagram

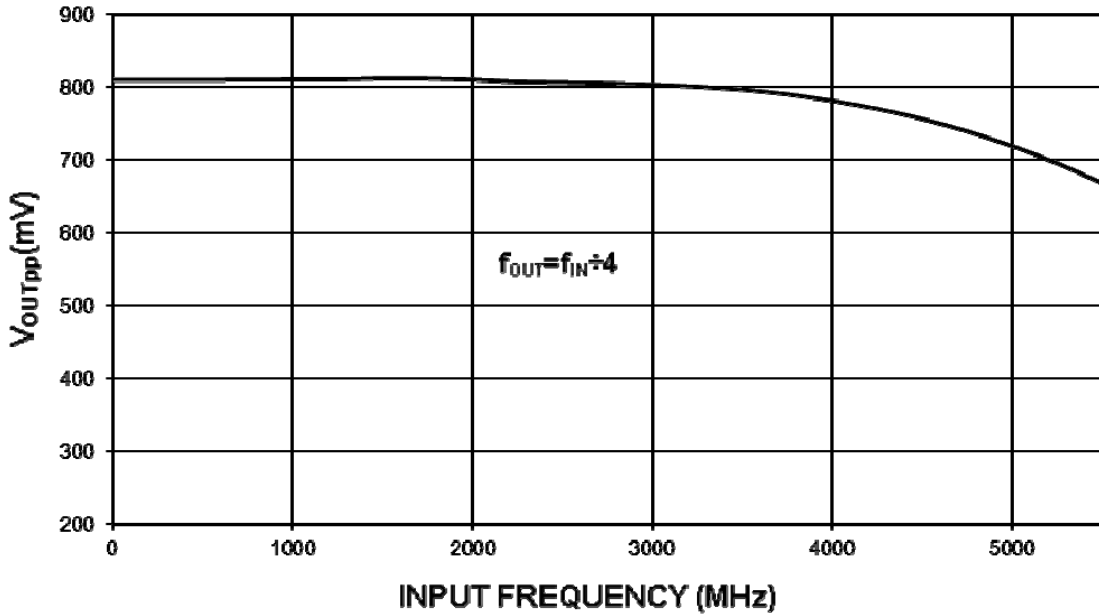

Figure 2 - Typical Large Signal Output Swing
 Measured with 750mV input, output terminated to VCC-2V via 50Ω resistors.

ELECTRICAL SPECIFICATIONS

Absolute Maximum Ratings are those values beyond which device life may be impaired.

Symbol	Characteristic	Condition	Rating	Unit
V _{CC}	PECL Power Supply	V _{EE} = 0V	0 to + 6.0	V
V _{I,PECL}	PECL Input Voltage	V _{EE} = 0V	0 to + 6.0	V
V _{EE}	ECL Power Supply	V _{CC} = 0V	-6.0 to 0	V
V _{I,ECL}	ECL Input Supply	V _{CC} = 0V	-6.0 to 0	V
I _{OUT}	Output Current	Continuous	50	mA
		Surge	100	
T _A	Operating Temperature Range	-	-40 to +85	°C
T _{STG}	Storage Temperature Range	-	-65 to +150	°C
ESD _{HBM}	Human Body Model Electro Static Discharge	-	2500	V
ESD _{MM}	Machine Model Electro Static Discharge	-	200	V
ESD _{CDM}	Charged Device Model Electro Static Discharge	-	2000	V

ECL DC Characteristics (VEE = -3.0V to -5.5V, VCC = GND)

Symbol	Characteristic	-40°C		0°C		25°C		85°C		Unit
		Min	Max	Min	Max	Min	Max	Min	Max	
V _{OH}	Output HIGH Voltage ¹	-1085	-880	-1025	-880	-1025	-880	-1025	-880	mV
V _{OL}	Output LOW Voltage ¹	-1830	-1555	-1810	-1620	-1810	-1620	-1810	-1620	mV
V _{IH}	Input HIGH Voltage	-1165	-880	-1165	-880	-1165	-880	-1165	-880	mV
V _{IL}	Input LOW Voltage	-1810	-1475	-1810	-1475	-1810	-1475	-1810	-1475	mV
V _{BB}	Reference Voltage	-1380	-1260	-1380	-1260	-1380	-1260	-1380	-1260	mV
I _{IH}	Input HIGH Current		150		150		150		150	μA
I _{IL}	Input LOW Current CLK	-150		-150		-150		-150		μA
	Input LOW Current RESET	0.5		0.5		0.5		0.5		
I _{EE}	Power Supply Current		33		33		33		37	mA

¹ Specified with each output terminated through 50Ω resistors to V_{CC} -2V.

LVPECL DC Characteristics (VEE = GND, VCC = +3.3V)

Symbol	Characteristic	-40°C		0°C		25°C		85°C		Unit
		Min	Max	Min	Max	Min	Max	Min	Max	
V _{OH}	Output HIGH Voltage ^{1,2}	2215	2420	2275	2420	2275	2420	2275	2420	mV
V _{OL}	Output LOW Voltage ^{1,2}	1470	1745	1490	1680	1490	1680	1490	1680	mV
V _{IH}	Input HIGH Voltage ¹	2135	2420	2135	2420	2135	2420	2135	2420	mV
V _{IL}	Input LOW Voltage ¹	1490	1825	1490	1825	1490	1825	1490	1825	mV
V _{BB}	Reference Voltage ¹	1920	2040	1920	2040	1920	2040	1920	2040	mV
I _{IH}	Input HIGH Current		150		150		150		150	μA
I _{IL}	Input LOW Current CLK	-150		-150		-150		-150		μA
	Input LOW Current RESET	0.5		0.5		0.5		0.5		
I _{EE}	Power Supply Current		33		33		33		37	mA

¹ For supply voltages other than 3.3V, use the ECL table values and ADD supply voltage value.

² Specified with each output terminated through 50Ω resistors to V_{CC} -2V.

PECL DC Characteristics (VEE = GND, VCC = +5.0V)

Symbol	Characteristic	-40°C		0°C		25°C		85°C		Unit
		Min	Max	Min	Max	Min	Max	Min	Max	
V _{OH}	Output HIGH Voltage ^{1,2}	3915	4120	3975	4120	3975	4120	3975	4120	mV
V _{OL}	Output LOW Voltage ^{1,2}	3170	3445	3190	3380	3190	3380	3190	3380	mV
V _{IH}	Input HIGH Voltage ¹	3835	4120	3835	4120	3835	4120	3835	4120	mV
V _{IL}	Input LOW Voltage ¹	3190	3525	3190	3525	3190	3525	3190	3525	mV
V _{BB}	Reference Voltage ¹	3620	3740	3620	3740	3620	3740	3620	3740	mV
I _{IH}	Input HIGH Current		150		150		150		150	µA
I _{IL}	Input LOW Current CLK	-150		-150		-150		-150		µA
	Input LOW Current RESET	0.5		0.5		0.5		0.5		
I _{EE}	Power Supply Current		33		33		33		37	mA

¹ For supply voltages other than 3.3V, use the ECL table values and ADD supply voltage value.

² Specified with each output terminated through 50Ω resistors to V_{CC} -2V.

AC Characteristics (VEE = -3.0V to -5.5V; VCC=GND or VEE=GND; VCC = +3.0V to +5.5V)

Symbol	Characteristic	-40°C			0°C			25°C			85°C			Unit
		Min	Typ	Max	Min	Typ	Max	Min	Typ	Max	Min	Typ	Max	
f _{MAX}	Maximum Toggle Frequency	4.2			4.2			4.2			4.2			GHz
t _{PLH} /t _{PHL}	CLK to Q̄	360	450	540	320	460	550	380	470	560	400	490	580	ps
	RESET to Q̄	310	460	610	340	460	580	360	460	560	380	480	580	ps
t _{SKEW}	Duty Cycle Skew			20			20			20			20	ps
V _{PP} (AC)	Input Swing	150		1000	150		1000	150		1000	150		1000	mV
V _{CMR}	Common Mode Range	V _{EE+}		V _{CC-}	V _{EE+}		V _{CC-}	V _{EE+}		V _{CC-}	V _{EE+}		V _{CC-}	
	V _{PP} < 500mV	1.2		0.4	1.1		0.4	1.1		0.4	1.1		0.4	V
	V _{PP} ≥ 500mV	1.4		0.4	1.3		0.4	1.3		0.4	1.3		0.4	V
t _R /t _F	Output Rise/Fall (20%-80%)	100		260	100		260	100		260	100		260	ps

Pin Description and Configuration

Pin Assignments for CTS100LVEL33N

Pin	Name	Type	Function
1	RESET	Input	Asynchronous Reset
2	CLK	Input	Clock Input
3	$\overline{\text{CLK}}$	Input	Inverting Clock Input
4	V_{BB}	Output	Reference Voltage
5	V_{EE}	Power	Negative Supply
6	\overline{Q}	Output	Inverting PECL Output
7	Q	Output	PECL Output
8	V_{CC}	Power	Positive Supply

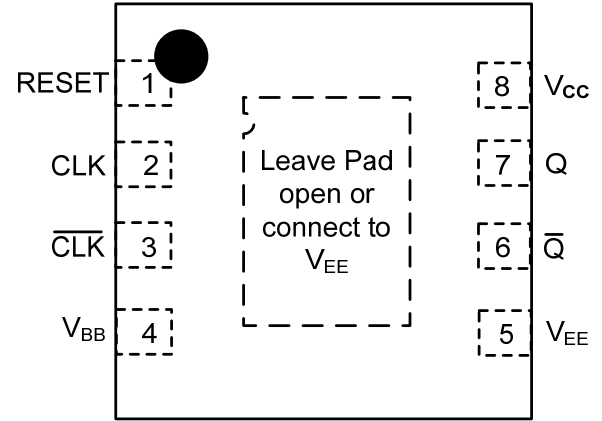

CTS100LVEL33N

Pin Assignments for CTS100LVEL33T & CTS100LVEL33D

Pin	Name	Type	Function
1	RESET	Input	Asynchronous Reset
2	CLK	Input	Clock Input
3	$\overline{\text{CLK}}$	Input	Inverting Clock Input
4	V_{BB}	Output	Reference Voltage
5	V_{EE}	Power	Negative Supply
6	\overline{Q}	Output	Inverting PECL Output
7	Q	Output	PECL Output
8	V_{CC}	Power	Positive Supply

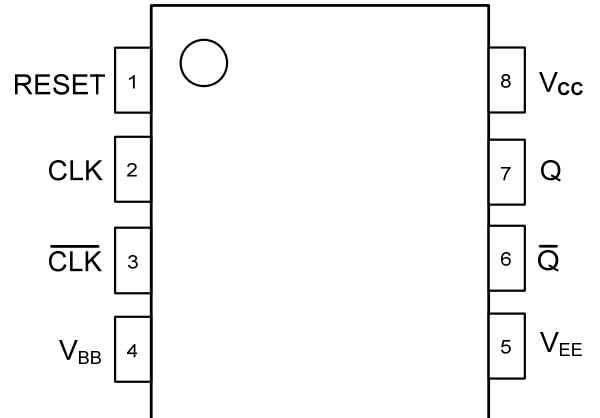

CTS100LVEL33T & CTS100LVEL33D

PACKAGE DIMENSIONS

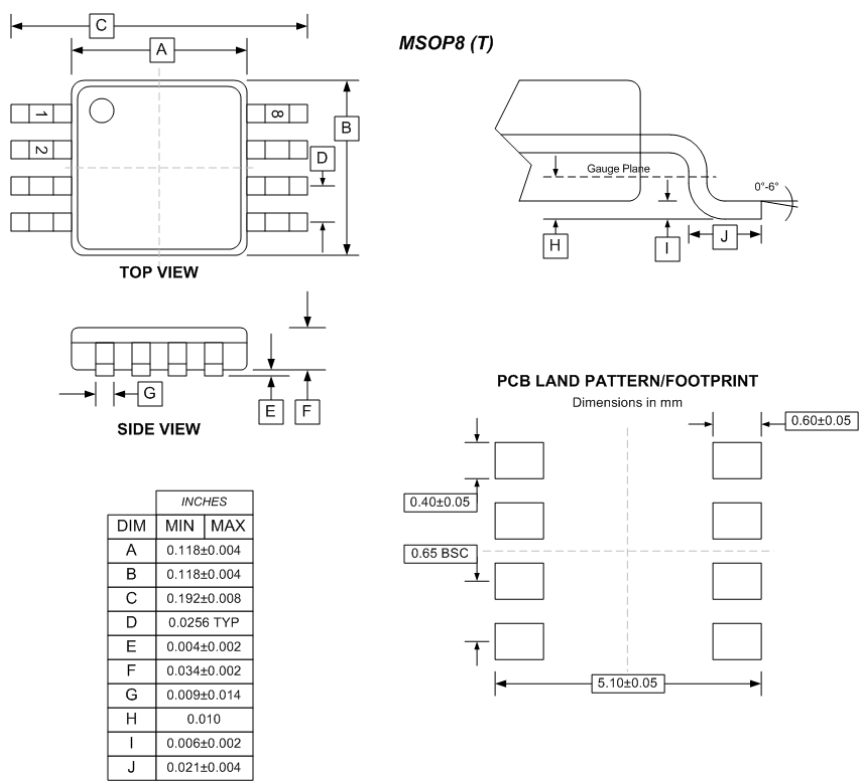
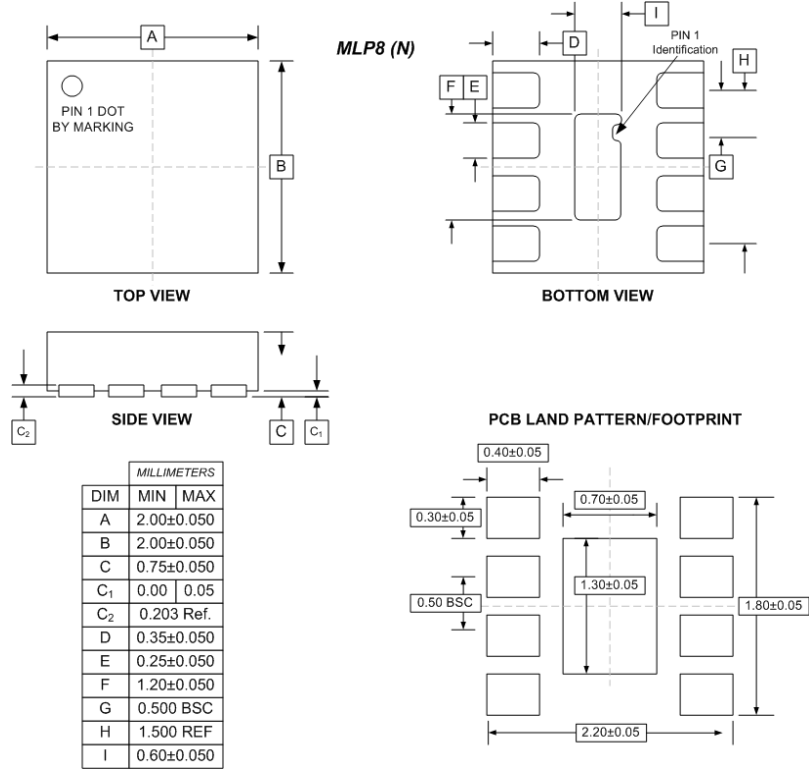

PACKAGE DIMENSIONS

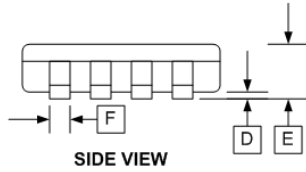
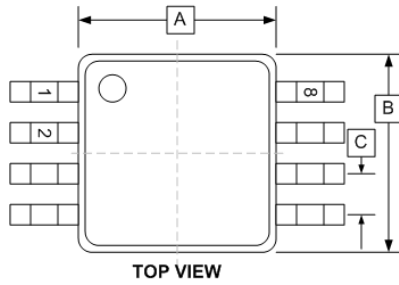

DIM	mm	
	MIN	MAX
A	3.81	3.99
B	4.80	4.98
C	1.27 BSC	
D	0.10	0.25
E	1.37	1.68
F	0.36	0.48
G	0.25	
H	0.19	0.25
I	0.41	0.86

SOIC8 (D)

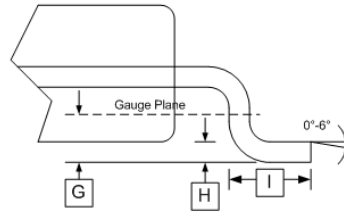

PCB LAND PATTERN/FOOTPRINT

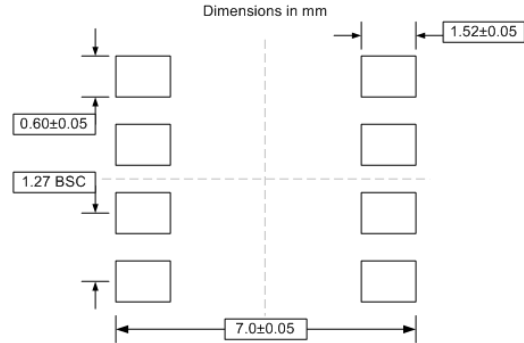

PART ORDERING INFORMATION

Part Number	Package	Marking
CTS100LVEL33NG	MLP8	C3G / YWW
CTS100LVEL33TG	MSOP8	HL33G / YYWW
CTS100LVEL33DG	SOIC8	CTS100G / LVEL33 / YYWW

Looking for pricing, stock, or lifecycle information?

Click below to explore more details on WIN SOURCE:

 [View TX1318T on WIN SOURCE](#)

 [Pulse Information](#)

Optimize Your Supply Chain with WIN SOURCE Solutions

-  Global Sourcing Solution
-  Obsolete Management
-  Cost Control Management
-  Shortage Management
-  Alternative Solution
-  Excess Inventory Management