



## TRIPLE 8-/10-BIT 165-/110-MSPS VIDEO AND GRAPHICS DIGITIZER WITH HORIZONTAL PLL

Check for Samples: [TVP7002](#)

### FEATURES

- **Analog Channels**
  - –6-dB to 6-dB Analog Gain
  - Analog Input Multiplexers (MUXs)
  - Automatic Video Clamp
  - Three Digitizing Channels, Each With Independently Controllable Clamp, Gain, Offset, and Analog-to-Digital Converter (ADC)
  - Clamping: Selectable Clamping Between Bottom Level and Mid Level
  - Offset: 1024-Step Programmable RGB or YPbPr Offset Control
  - Gain: 8-Bit Programmable Gain Control
  - ADC: 8-/10-Bit 165-/110-MSPS ADC
  - Automatic Level Control (ALC) Circuit
  - Composite Sync: Integrated Sync-on-Green Extraction From Green/Luminance Channel
  - Support for DC- and AC-Coupled Input Signals
  - Supports Component Video Standards 480i, 576i, 480p, 576p, 720p, 1080i, and 1080p
  - Supports PC Graphics Inputs up to UXGA
    - Programmable RGB-to-YCbCr Color Space Conversion
- **Horizontal PLL**
  - Fully Integrated Horizontal PLL for Pixel Clock Generation
  - 12-MHz to 165-MHz Pixel Clock Generation From HSYNC Input
  - Adjustable Horizontal PLL Loop Bandwidth for Minimum Jitter
  - 5-Bit Programmable Subpixel Accurate Positioning of Sampling Phase
- **Output Formatter**
  - Supports 20-bit 4:2:2 Outputs With Embedded Syncs
  - Support for RGB/YCbCr 4:4:4 and YCbCr 4:2:2 Output Modes to Reduce Board Traces
  - Dedicated DATACLK Output With Programmable Output Polarity for Easy Latching of Output Data
- **System**
  - Industry-Standard Normal/Fast I<sup>2</sup>C Interface With Register Readback Capability
  - Space-Saving 100-Pin TQFP Package
  - Thermally-Enhanced PowerPAD™ Package for Better Heat Dissipation

### APPLICATIONS

- LCD TVs/Monitors/Projectors
- DLP TVs/Projectors
- PDP TVs/Monitors
- LCOS TVs/Monitors
- PCTV Set-Top Boxes
- Digital Image Processing
- Video Capture/Video Editing
- Scan Rate/Image Resolution Converters
- Video Conferencing
- Video/Graphics Digitizing Equipment

### DESCRIPTION

The TVP7002 is a complete solution for digitizing video and graphic signals in RGB or YPbPr color spaces. The device supports pixel rates up to 165 MHz. Therefore, it can be used for PC graphics digitizing up to the VESA standard of UXGA (1600 × 1200) resolution at a 60-Hz screen refresh rate, and in video environments for the digitizing of digital TV formats, including HDTV up to 1080p.



Please be aware that an important notice concerning availability, standard warranty, and use in critical applications of Texas Instruments semiconductor products and disclaimers thereto appears at the end of this data sheet.

PowerPAD is a trademark of Texas Instruments.

All other trademarks are the property of their respective owners.

The TVP7002 is powered from 3.3-V and 1.9-V supply and integrates a triple high-performance analog-to-digital (A/D) converter with clamping functions and variable gain, independently programmable for each channel. The clamp timing window is provided by an external pulse or can be generated internally. The TVP7002 includes analog slicing circuitry on the SOG inputs to support sync-on-luminance or sync-on-green extraction. In addition, TVP7002 can extract discrete HSYNC and VSYNC from composite sync using a sync slicer.

The TVP7002 also contains a complete horizontal phase-locked loop (PLL) block to generate a pixel clock from the HSYNC input. Pixel clock output frequencies range from 12 MHz to 165 MHz.

All programming of the device is done via an industry-standard I<sup>2</sup>C interface, which supports both reading and writing of register settings. The TVP7002 is available in a space-saving 100-pin TQFP PowerPAD package.

**Ordering Information<sup>(1)</sup>**

T <sub>A</sub>	PACKAGED DEVICES	PACKAGE OPTION
	100-PIN PLASTIC FLATPACK PowerPAD	
0°C to 70°C	TVP7002PZP	Tray
	TVP7002PZPR	Reel

(1) For the most current package and ordering information, see the Package Option Addendum at the end of this document, or see the TI web site at [www.ti.com](http://www.ti.com).

**Functional Block Diagram**

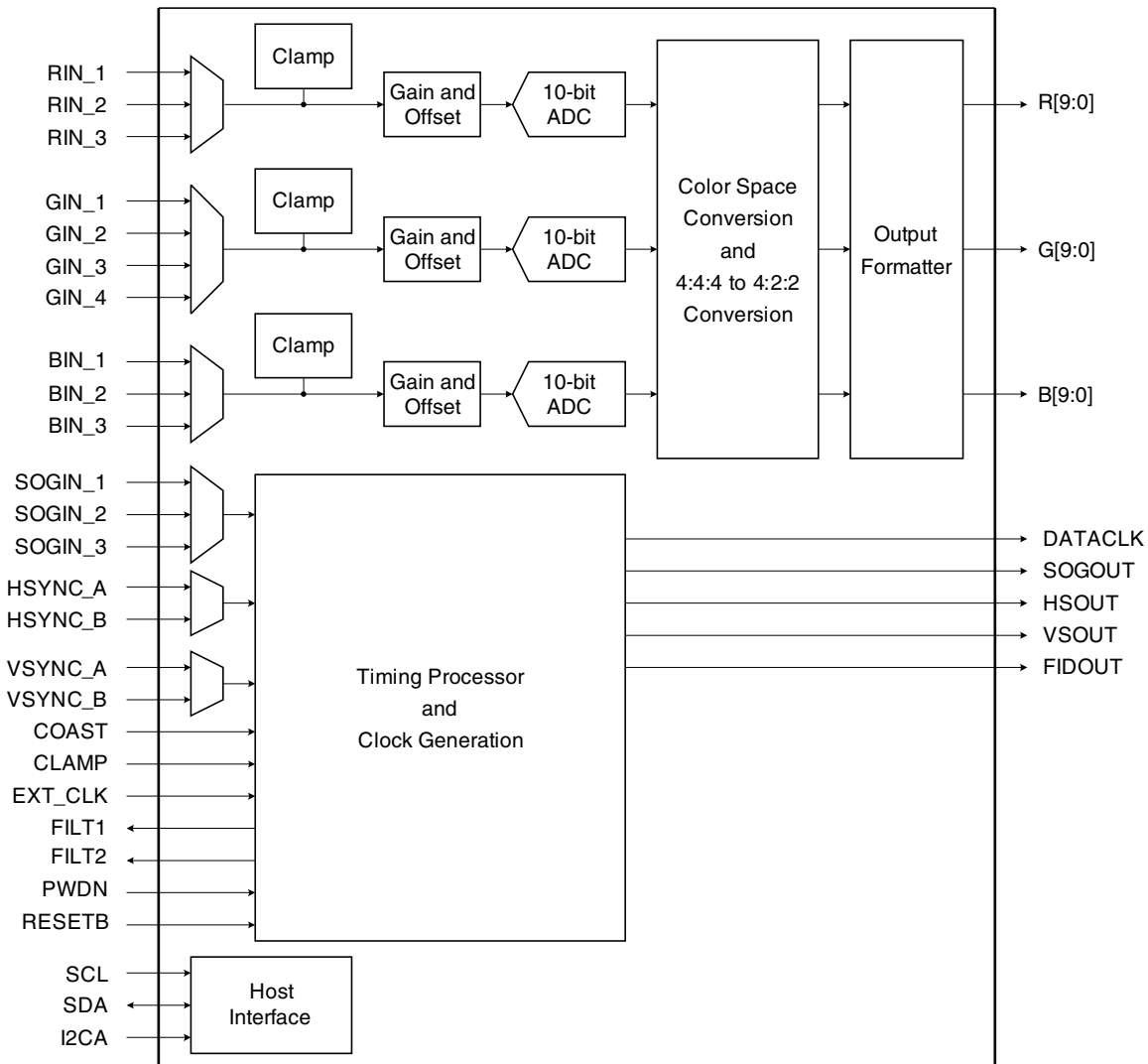

Terminal Assignments

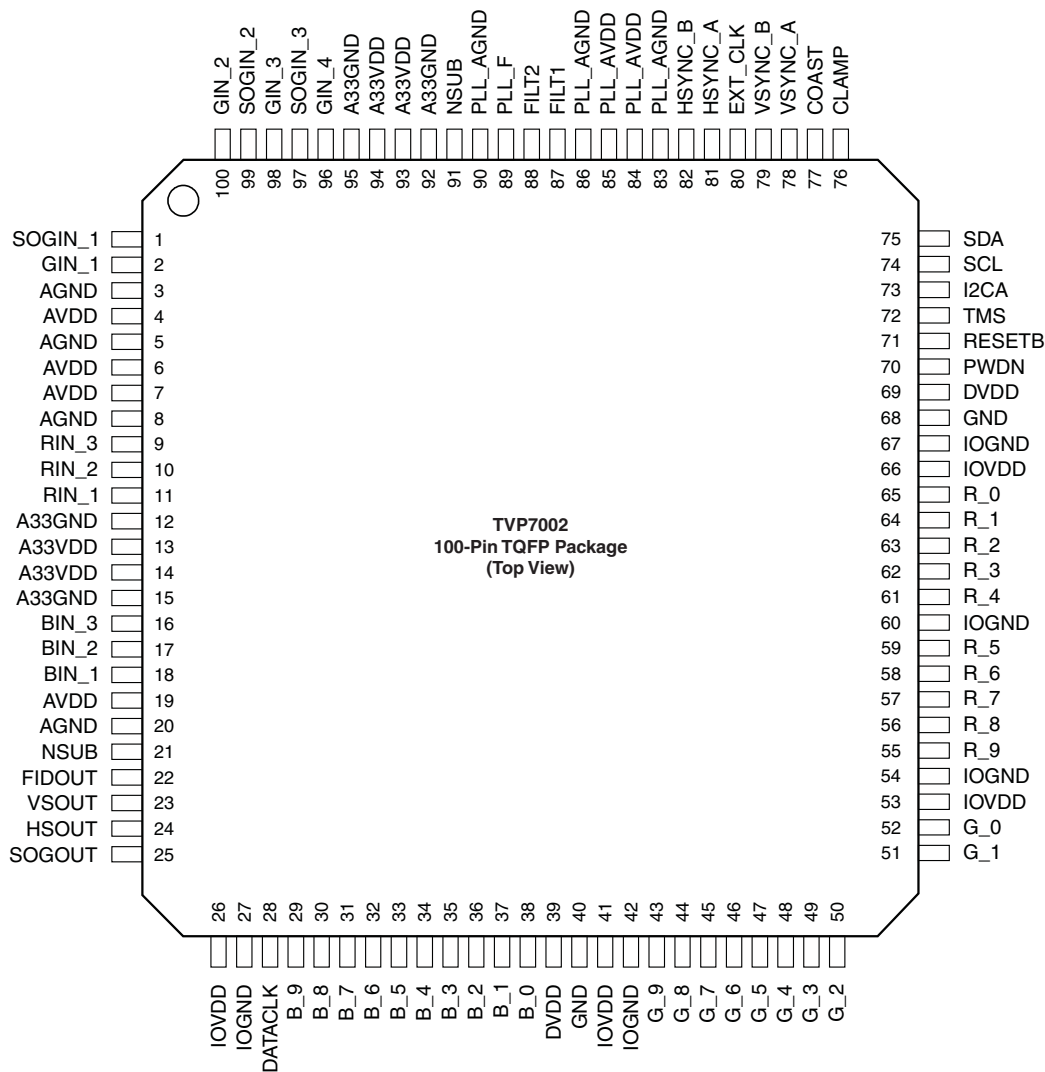

**Table 1. Terminal Functions**

TERMINAL		I/O	DESCRIPTION
NAME	NO.		
<b>Analog Video</b>			
RIN_1	11	I	Analog video input for R/Pr 1
RIN_2	10	I	Analog video input for R/Pr 2
RIN_3	9	I	Analog video input for R/Pr 3
GIN_1	2	I	Analog video input for G/Y 1
GIN_2	100	I	Analog video input for G/Y 2
GIN_3	98	I	Analog video input for G/Y 3
GIN_4	96	I	Analog video input for G/Y 4
BIN_1	18	I	Analog video input for B/Pb 1
BIN_2	17	I	Analog video input for B/Pb 2
BIN_3	16	I	Analog video input for B/Pb 3
The inputs must be ac coupled. The recommended coupling capacitor is 0.1 $\mu$ F. Unused analog inputs should be connected to ground using a 10-nF capacitor.			
<b>Clock Signals</b>			
DATACLK	28	O	Data clock output
EXT_CLK	80	I	External clock input. May be used as a timing reference for the mode detection block instead of the internal clock reference. May also be used as the ADC sample clock instead of the H-PLL generated clock.
<b>Digital Video</b>			
R[9:0]	55–59, 61–65	O	Digital video output of R/Cr, R[9] is the most significant bit (MSB).
G[9:0]	43–52	O	Digital video output of G/Y, G[9] is the MSB.
B[9:0]	29–38	O	Digital video output of B/Cb, B[9] is the MSB. For 4:2:2 mode, multiplexed CbCr data is output on B[9:0]. Unused outputs can be left unconnected.
<b>Miscellaneous Signals</b>			
PWDN	70	I	Power down input 0 = Normal mode 1 = Power down
RESETB	71	I	Reset input, active low. Outputs are placed in a high-impedance mode during reset (see <a href="#">Table 11</a> ).
TMS	72	I	Test mode select input, active high. Used to enable scan test mode. For normal operation, connect to ground.
FILT1	87	O	External filter connection for the horizontal PLL. A 0.1- $\mu$ F capacitor in series with a 1.5-k $\Omega$ resistor should be connected from this pin to pin 89 (see <a href="#">Figure 4</a> ).
FILT2	88	O	External filter connection for the horizontal PLL. A 4.7-nF capacitor should be connected from this pin to pin 89 (see <a href="#">Figure 4</a> ).
PLL_F	89	I	Horizontal PLL filter internal supply connection
<b>Host Interface</b>			
I2CA	73	I	I <sup>2</sup> C slave address input. The I <sup>2</sup> C slave address must be configured with an external pullup or pulldown resistor (see <a href="#">Table 10</a> ). 0 = Slave address = B8h 1 = Slave address = BAh
SCL	74	I	I <sup>2</sup> C clock input
SDA	75	I/O	I <sup>2</sup> C data bus

**Table 1. Terminal Functions (continued)**

TERMINAL		I/O	DESCRIPTION
NAME	NO.		
<b>Power Supplies</b>			
NSUB	21, 91	I	Substrate ground. Connect to analog ground.
A33VDD	13, 14, 93, 94	I	Analog power. Connect to 3.3 V.
A33GND	12, 15, 92, 95	I	Analog 3.3-V return. Connect to ground.
AGND	3, 5, 8, 20	I	Analog 1.9-V return. Connect to ground.
AVDD	4, 6, 7, 19	I	Analog power. Connect to 1.9 V.
PLL_AVDD	84, 85	I	PLL analog power. Connect to 1.9 V.
PLL_AGND	83, 86, 90	I	PLL analog power return. Connect to ground.
DGND	40, 68	I	Digital return. Connect to ground.
DVDD	39, 69	I	Digital power. Connect to 1.9 V.
IOGND	27, 42, 54, 60, 67	I	Digital power return. Connect to ground.
IOVDD	26, 41, 53, 66	I	Digital power. Connect to 3.3 V or less for reduced noise.
<b>Sync Signals</b>			
CLAMP	76	I	External clamp input. Unused inputs can be connected to ground.
COAST	77	I	External PLL COAST signal input. Unused inputs can be connected to ground.
VSYNC_A	78	I	Vertical sync input A
VSYNC_B	79	I	Vertical sync input B Unused inputs can be connected to ground.
HSYNC_A	81	I	Horizontal sync input A
HSYNC_B	82	I	Horizontal sync input B Unused inputs can be connected to ground.
SOGIN_1	1	I	Sync-on-green input 1
SOGIN_2	99	I	Sync-on-green input 2
SOGIN_3	97	I	Sync-on-green input 3 Unused inputs should be connected to ground using a 1-nF capacitor.
FIDOUT	22	O	Field ID output. Using register 17h, this pin may also be programmed to be the internal sync processing REFCLK output, coast output, clamp pulse output, or data enable.
VSOUT	23	O	Vertical sync output
HSOUT	24	O	Horizontal sync output
SOGOUT	25	O	Sync-on-green slicer output

## Absolute Maximum Ratings<sup>(1)</sup>

over operating free-air temperature range (unless otherwise noted)

Supply voltage range	IOVDD to IOGND	–0.5 V to 4.5 V
	DVDD to DGND	–0.5 V to 2.3 V
	PLL_AVDD to PLL_AGND and AVDD to AGND	–0.5 V to 2.3 V
	A33VDD to A33GND	–0.5 V to 4.5 V
Digital input voltage range	V <sub>I</sub> to DGND	–0.5 V to 4.5 V
Analog input voltage range	A <sub>I</sub> to A33GND	–0.2 V to 2.3 V
Digital output voltage range	V <sub>O</sub> to DGND	–0.5 V to 4.5 V
T <sub>A</sub>	Operating free-air temperature range	0°C to 70°C
T <sub>stg</sub>	Storage temperature range	–65°C to 150°C

- (1) Stresses beyond those listed under *Absolute Maximum Ratings* may cause permanent damage to the device. These are stress ratings only and functional operation of the device at these or any other conditions beyond those indicated under *Recommended Operating Conditions* is not implied. Exposure to absolute-maximum-rated conditions for extended periods may affect device reliability.

## Thermal Specifications

PARAMETER		TEST CONDITIONS <sup>(1)</sup>	MIN	TYP	MAX	UNIT
θ <sub>JA</sub>	Junction-to-ambient thermal resistance, still air	Thermal pad soldered to 4-layer High-K PCB		17.28		°C/W
θ <sub>JC</sub>	Junction-to-case thermal resistance, still air	Thermal pad soldered to 4-layer High-K PCB		0.154		°C/W
T <sub>J(MAX)</sub>	Maximum junction temperature for reliable operation				110	°C

- (1) Exposed thermal pad must be soldered to JEDEC High-K PCB with adequate ground plane. If split ground planes are used, connect the thermal pad to the digital ground plane.

## Recommended Operating Conditions

		MIN	NOM	MAX	UNIT
IOVDD	Digital I/O supply voltage	3	3.3	3.6	V
DVDD	Digital supply voltage	1.8	1.9	2	V
PLL_AVDD	Analog supply voltage for horizontal PLL	1.8	1.9	2	V
AVDD	Analog supply voltage	1.8	1.9	2	V
A33VDD	Analog supply voltage	3	3.3	3.6	V
V <sub>I(P-P)</sub>	Analog input voltage (ac coupling necessary)	0.5		2	V
V <sub>IH</sub>	Digital input voltage high	0.7 IOVDD			V
V <sub>IL</sub>	Digital input voltage low		0.3 IOVDD		V
I <sub>OH</sub>	High-level output current			2	mA
I <sub>OL</sub>	Low-level output current			–2	mA
I <sub>OH_DATACLK</sub>	DATACLK high-level output current			4	mA
I <sub>OL_DATACLK</sub>	DATACLK low-level output current			–4	mA
	ADC conversion rate	12		162	MHz
T <sub>A</sub>	Operating free-air temperature	0		70	°C

## Electrical Characteristics

 IOVDD = 3.3 V, DVDD = 1.9 V, PLL\_AVDD = 1.9 V, AVDD = 1.9 V, A33VDD = 3.3 V, T<sub>A</sub> = 25°C

PARAMETER		TEST CONDITIONS <sup>(1)</sup>	TYP <sup>(2)</sup>	TYP <sup>(3)</sup>	UNIT
<b>Power Supply</b>					
I <sub>A33VDD</sub>	3.3-V supply current	78.75 MHz, BC = 5	67	67	mA
I <sub>IOVDD</sub>	3.3-V supply current	78.75 MHz, BC = 5	21	56	mA
I <sub>AVDD</sub>	1.9-V supply current	78.75 MHz, BC = 5	206	209	mA
I <sub>PLL_VDD</sub>	1.9-V supply current	78.75 MHz, BC = 5	16	16	mA
I <sub>DVDD</sub>	1.9-V supply current	78.75 MHz, BC = 5	30	46	mA
P <sub>TOT</sub>	Total power dissipation, normal mode	78.75 MHz, BC = 5	743	893	mW
I <sub>A33VDD</sub>	3.3-V supply current	162 MHz, BC = 8	110	110	mA
I <sub>IOVDD</sub>	3.3-V supply current	162 MHz, BC = 8	35	102	mA
I <sub>AVDD</sub>	1.9-V supply current	162 MHz, BC = 8	275	279	mA
I <sub>PLL_VDD</sub>	1.9-V supply current	162 MHz, BC = 8	22	23	mA
I <sub>DVDD</sub>	1.9-V supply current	162 MHz, BC = 8	56	89	mA
P <sub>TOT</sub>	Total power dissipation, normal mode	162 MHz, BC = 8	1112	1403	mW
P <sub>DOWN</sub>	Total power dissipation, power-down mode		15	15	mW

- (1) BC = ADC bias control setting in I<sup>2</sup>C register, 2Ch
- (2) SMPTE color bar RGB input pattern used
- (3) Worst-case vertical line RGB input pattern used

## Electrical Characteristics

IOVDD = 3.3 V, DVDD = 1.9 V, PLL\_AVDD = 1.9 V, AVDD = 1.9 V, A33VDD = 3.3 V, T<sub>A</sub> = 0°C to 70°C (unless otherwise noted)

PARAMETER		TEST CONDITIONS <sup>(1)</sup>	MIN	TYP	MAX	UNIT
<b>Analog Interface</b>						
	Input voltage range	By design	0.5	1	2	V <sub>pp</sub>
Z <sub>I</sub>	Input impedance, analog video inputs	By design		500		kΩ
<b>Digital Logic Interface</b>						
C <sub>I</sub>	Input capacitance	By design		10		pF
Z <sub>I</sub>	Input impedance	By design		500		kΩ
V <sub>OH</sub>	Output voltage high	I <sub>OH</sub> = 2 mA	0.8 IOVDD			V
V <sub>OL</sub>	Output voltage low	I <sub>OL</sub> = -2 mA		0.2 IOVDD		V
V <sub>OH_SCLK</sub>	DATACLK output voltage high	I <sub>OH</sub> = 4 mA	0.8 IOVDD			V
V <sub>OL_SCLK</sub>	DATACLK output voltage low	I <sub>OH</sub> = -4 mA		0.2 IOVDD		V
V <sub>IH</sub>	High-level input voltage	By design	0.7 IOVDD			V
V <sub>IL</sub>	Low-level input voltage	By design		0.3 IOVDD		V
<b>ADCs</b>						
	ADC full-scale input range	Clamp disabled	0.95	1	1.05	V <sub>pp</sub>
	ADC resolution	10-bit range			10	bits
DNL	DC differential nonlinearity	10 bit, 110 MHz, BC = 5	-1	±0.5	+1	LSB
		8 bit, 162 MHz, BC = 8	-1	±0.5	+1	
INL	DC integral nonlinearity	10 bit, 110 MHz, BC = 5	-4	±1	+4	LSB
		8 bit, 162 MHz, BC = 8	-4	±1	+4	
	Missing code	10 bit, 110 MHz, BC = 5		none		
		8 bit, 162 MHz, BC = 8		none		
SNR	Signal-to-noise ratio	10 MHz, 1 V <sub>P-P</sub> at 110 MSPS		55		dB
	Analog 3-dB bandwidth	By design	350	500		MHz
<b>Horizontal PLL</b>						
	Clock jitter			500		ps
	Phase adjustment			11.6		degree
	VCO frequency range	By design	12		162	MHz
<b>Analog ADC Channel</b>						
	Coarse gain full-scale control range	Gain control value N <sub>G</sub> = 15		±6		dB
	Coarse offset full-scale control range	Referred to 10-bit ADC output		±124		counts
	Coarse offset step size	Referred to 10-bit ADC output		4		counts
<b>Sync Processing</b>						
	Internal clock reference frequency	By design		6.5		MHz

(1) BC = ADC bias control setting in I<sup>2</sup>C register, 2Ch

### Timing Requirements

PARAMETER		TEST CONDITIONS <sup>(1)</sup>	MIN	TYP	MAX	UNIT
<b>Clocks, Video Data, Sync Timing</b>						
	Positive duty cycle, DATACLK (CLK POL = 0)		48	50	52	%
	Positive duty cycle, DATACLK (CLK POL = 1)		41	43	45	%
t1	DATACLK rise time	10% to 90%		1		ns
t2	DATACLK fall time	90% to 10%		1		ns
t3 (RGB data)	RGB output delay time		0		1.5	ns

(1) Measured at 162 MHz with 22-Ω series termination resistor and 10-pF load. Specified by characterization only. Data is clocked out on the rising edge of DATACLK with Reg 18h CLK POL=0 and is clocked out on the falling edge of DATACLK with CLK POL=1.

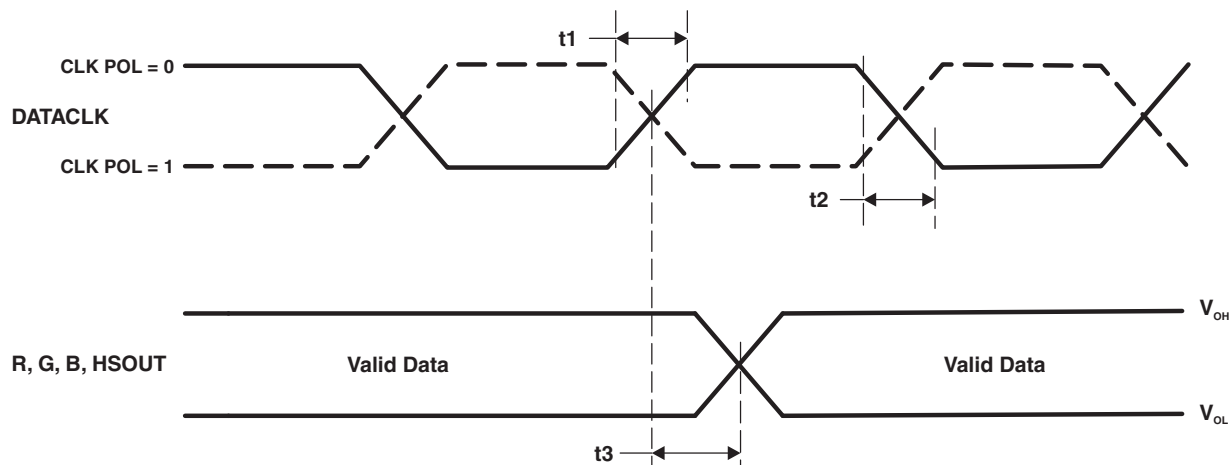

Figure 1. Clock, Video Data, and HSOUT Timing

### Timing Requirements

PARAMETER		TEST CONDITIONS	MIN	TYP	MAX	UNIT
<b>I<sup>2</sup>C Host Port</b>						
t1	Bus free time between Stop and Start	Specified by design	1.3			μs
t2	Setup time for a (repeated) Start condition	Specified by design	0.6			μs
t3	Hold time (repeated) Start condition	Specified by design	0.6			μs
t4	Setup time for a Stop condition	Specified by design	0.6			ns
t5	Data setup time	Specified by design	100			ns
t6	Data hold time	Specified by design	0	0.9		μs
t7	Rise time, SDA and SCL signal	Specified by design		250		ns
t8	Fall time, SDA and SCL signal	Specified by design </td <td></td> <td>250</td> <td></td> <td>ns</td>		250		ns
C <sub>b</sub>	Capacitive load for each bus line	Specified by design		400		pF
f <sub>I2C</sub>	I <sup>2</sup> C clock frequency	Specified by design		400		kHz

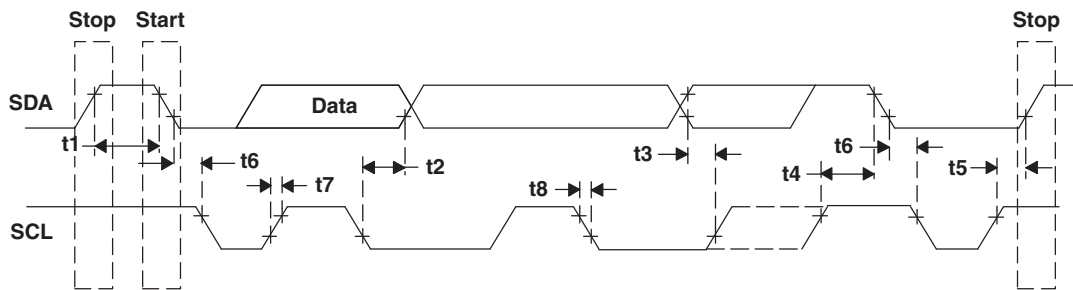

Figure 2. I<sup>2</sup>C Host Port Timing

## FUNCTIONAL DESCRIPTION

### Analog Channel

The TVP7002 contains three identical analog channels that are independently programmable. Each channel consists of a clamping circuit, programmable gain control, programmable offset control, and an ADC.

### Analog Input Switch Control

TVP7002 has three analog channels that accept up to ten video inputs. The user can configure the internal analog video switches via the I<sup>2</sup>C interface. The ten analog video inputs can be used for different input configurations, some of which are:

- Up to three SDTV, EDTV, or HDTV component video inputs (limited by number of SOG inputs)
- Up to two 5-wire PC graphics inputs (limited by number of HSYNC and VSYNC inputs)

The input selection is performed by the input select register at I<sup>2</sup>C subaddress 19h a 1Ah (see Input Mux Select 1 and Input Mux Select 2).

### Supported Video Formats

The TVP7002 supports A/D conversion of SDTV (480i, 576i), EDTV (480p, 576p), and HDTV (720p, 1080i, 1080p) YPbPr component video inputs. The TVP7002 also supports A/D conversion and color space conversion of all standard PC graphics formats (RGB) from VGA up to UXGA. The internal sync separator provides support for field rates (VSYNC frequencies) at or above 40 Hz. Separated VSYNC or an external sync separator must be used to support formats having field rates less than 40 Hz. A summary of the analog video standards supported by the TVP7002 module is show in [Table 2](#).

**Table 2. Analog Video Standards**

VIDEO FORMAT	VIDEO STANDARDS
SDTV (YPbPr component)	480i, 576i
EDTV (YPbPr component)	480p, 576p
HDTV (YPbPr component)	720p50, 720p60, 1080i50, 1080i60, 1080p50, 1080p60
PC graphics (RGB component)	VGA to UXGA
SCART (RGB component)	576i

### Analog Input Clamping

The TVP7002 provides dc restoration for all analog video inputs including the SOG slicer inputs. The dc restoration circuit (a.k.a. clamp circuit) restores the ac-coupled video signal to a fixed dc level. One dc restoration circuit is implemented prior to each of the three ADCs, and a fourth one is located prior to the SOG slicer. The dc restoration circuit can be programmed to operate as either a sync-tip clamp (a.k.a. coarse clamp) or a back-porch clamp (a.k.a. fine clamp). The sync-tip clamp always clamps the video sync-tip level near the bottom of the ADC range. The back-porch type clamp supports two clamping levels (bottom level and mid level) that are selectable using bits 0, 1, and 2 of register 10h. When using the fine bottom-level clamp, an optional 300-mV common-mode offset may be selected using bit 7 of register 2Ah.

In general, the analog video input being used for horizontal synchronization purposes should always use the sync-tip clamp; all other analog video inputs should use the back-porch clamp. The advantage of the back-porch clamp is that it has negligible video droop or tilt across a video line.

The selection between bottom- and mid-level clamping is performed by I<sup>2</sup>C subaddress 10h (see *Sync-On-Green Threshold*). The fine clamps must also be enabled via I<sup>2</sup>C register 2Ah for proper operation. The internal clamping time can be adjusted using the I<sup>2</sup>C clamp start and width registers at subaddress 05h and 06h, respectively (see *Clamp Start* and *Clamp Width*).

**Table 3. Recommended Clamp Setting by Video Mode**

VIDEO MODE	SOG INPUT (Y/G)	GREEN ADC CHANNEL (Y/G)	RED ADC CHANNEL (Pr/R)	BLUE ADC CHANNEL (Pb/B)
YPbPr component	Coarse	Fine Bottom Level	Fine Mid Level	Fine Mid Level
PC graphics	Coarse	Fine Bottom Level	Fine Bottom Level	Fine Bottom Level
SCART-RGB	Coarse	Fine Bottom Level	Fine Bottom Level	Fine Bottom Level

A single-pole low-pass filter with three selectable cutoff frequencies (0.5, 1.7, and 4.8 MHz) is implemented in the feedback loop of the sync-tip clamp circuit.

### Programmable Gain Control

The TVP7002 provides a 4-bit coarse analog gain control (before A/D conversion) and an 8-bit fine digital gain control (after A/D conversion). The coarse analog gain and the fine digital gain are both independently programmable for each ADC channel.

#### Coarse Gain Control

The 4-bit coarse analog gain control has a 4:1 linear gain control range defined by the following equation.

$$\text{Coarse Gain} = 0.5 + N_{CG}/10, \text{ where } 0 \leq N_{CG} \leq 15$$

$$0.5 \leq \text{Coarse Gain} \leq 2.0$$

$$\text{Default: } N_{CG} = 7 \text{ (Coarse Gain} = 1.2)$$

The 4-bit coarse gain control can scale a signal with a voltage-input compliance of 0.5 V<sub>P,P</sub> to 2 V<sub>P,P</sub> to a full-scale 10-bit A/D output code range. The minimum gain corresponds to a code 0h (2-V<sub>P,P</sub> full-scale input, -6-dB gain) while the maximum gain corresponds to code Fh (0.5-V<sub>P,P</sub> full scale, +6 dB gain). The 4-bit coarse gain control is independently controllable for each ADC channel (Red Coarse Gain, Green Coarse Gain, and Blue Coarse Gain).

#### Fine Gain Control

The 8-bit fine digital gain control has a 2:1 linear gain control range defined by the following equation.

$$\text{Fine Gain} = 1.0 + N_{FG}/256 \text{ where } 0 \leq N_{FG} \leq 255$$

$$1.0 \leq \text{Fine Gain} < 2.0$$

$$\text{Default: } N_{FG} = 0 \text{ (Fine Gain} = 1.0)$$

The 8-bit fine gain control is independently controllable for each ADC channel (Red Fine Gain, Green Fine Gain, and Blue Fine Gain). For a normal PC graphics input, the fine gain is used mostly.

### Programmable Offset Control

The TVP7002 provides a 6-bit coarse analog offset control (before A/D conversion) and a 10-bit fine digital offset control (after A/D conversion). The coarse analog offset and the fine digital offset are both independently programmable for each ADC channel.

#### Coarse Offset Control

A 6-bit code sets the coarse offset (Red Coarse Offset, Green Coarse Offset, Blue Coarse Offset) with individual adjustment per channel. The coarse offset ranges from -32 counts to +31 counts. The coarse offset registers apply before the ADC.

#### Fine Offset Control

A 10-bit fine offset registers (Red Fine Offset, Green Fine Offset, Blue Fine Offset) apply after the ADC. The fine offset ranges from -512 counts to +511 counts.

### Automatic Level Control (ALC)

The ALC circuit maintains the level of the signal to be set at a value that is programmed at the fine offset I<sup>2</sup>C register. It consists of a pixel averaging filter and feedback loop. This ALC function can be enabled or disabled by the I<sup>2</sup>C register at subaddress 26h.

The ALC circuit needs a timing pulse generated internally but the user should program the position properly. The ALC pulse must be positioned after the clamp pulse. The position of ALC pulse is controlled by ALC placement I<sup>2</sup>C register at address 31h. This is available only for internal ALC pulse timing. When using an external clamp pulse, the fine clamp and the ALC both start on the leading edge of the external clamp pulse. Therefore, it is recommended to keep the external clamp pulse as long as possible.

### Analog-to-Digital Converters (ADCs)

All ADCs have a resolution of 10 bits and can operate up to 165 MSPS. All A/D channels receive an identical clock from the on-chip phase-locked loop (PLL) at a frequency between 12 MHz and 165 MHz. All ADC reference voltages are generated internally. Also the external sampling clock can be used.

### Horizontal PLL

The horizontal PLL generates a high-frequency internal clock used by the ADC sampling and data clocking out to derive the pixel output frequency with programmable phase. The reference signal for this PLL is the horizontal sync signal supplied on the HSYNC input or from extracted horizontal sync of the sync slicer block for embedded sync signals. The horizontal PLL consists of a phase detector, charge pump, loop filter, voltage controlled oscillator (VCO), phase select, feedback divider, and post divider. The horizontal PLL block diagram is shown in Figure 3.

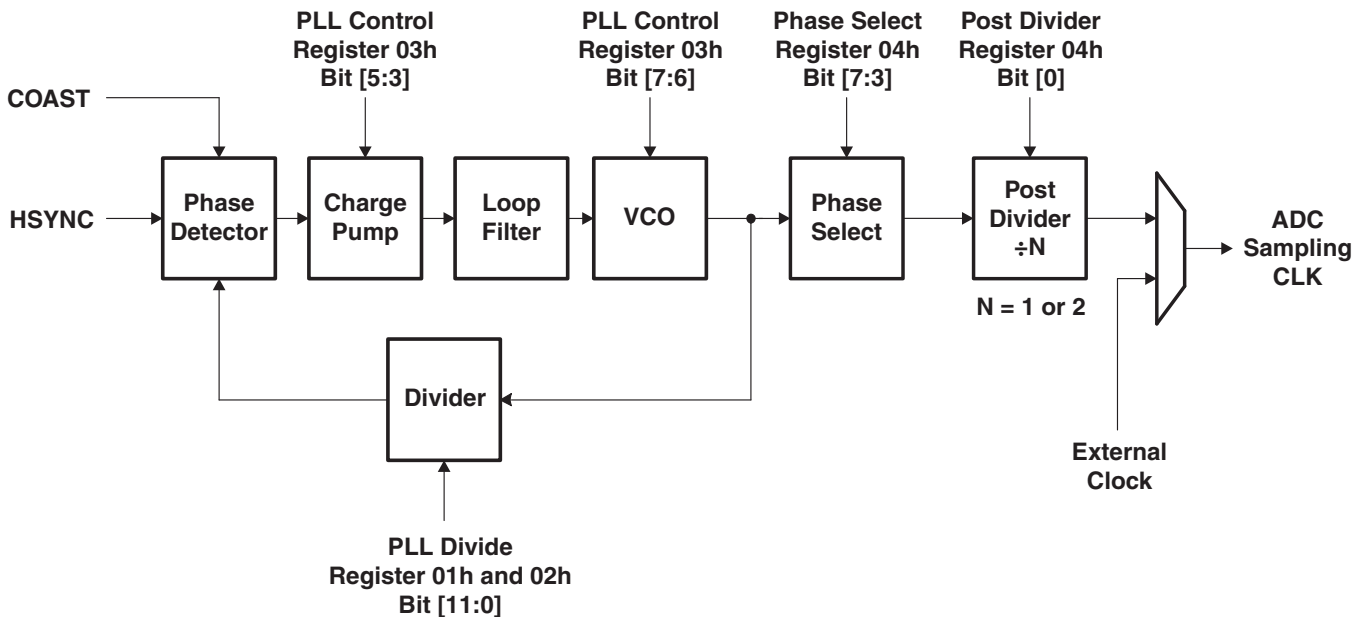

Figure 3. Horizontal PLL Block Diagram

The COAST signal is used to allow the PLL to keep running at the same frequency, in the absence of the incoming HSYNC signal or disordered HSYNC period. This is useful during the vertical sync period, or any other time that the HSYNC is not available.

There are several PLL controls to produce the correct sampling clock. The 12-bit feedback divider register is programmable to select exact multiplication number to generate the pixel clock in the range of 12 MHz to 165 MHz. The 3-bit loop filter current control register is to control the charge pump current that drives the low-pass loop filter. The applicable current values are listed in the Table 4.

The purpose of the 2-bit VCO range control is to improve the noise performance of the TVP7002. The frequency ranges for the VCO are shown in Table 4. The phase of the ADC sample clock generated by the horizontal PLL can be accurately controlled in 32 uniform steps over a single clock period ( $360/32 = 11.25$  degrees phase resolution) using the phase select register located at subaddress 04h.

The horizontal PLL characteristics are determined by the loop filter design, the PLL charge pump current, and the VCO range setting. The loop filter design is shown in Figure 4. Supported settings of VCO range and charge pump current for VESA standard display modes are listed in Table 4.

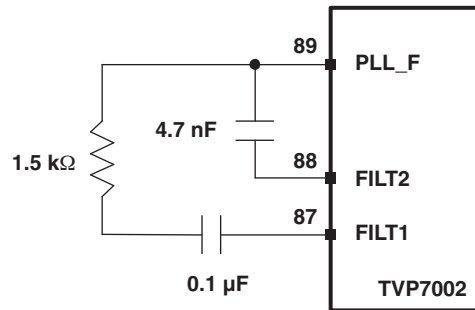

Figure 4. Horizontal PLL Loop Filter

In addition to sourcing the ADC sample clock from the horizontal PLL, an external pixel clock can be used (from pin 80).

Table 4. Recommended VCO Range and Charge Pump Current Settings for Supporting Standard Display Formats

STANDARD	RESOLUTION	FRAME RATE (Hz)	LINE RATE (kHz)	PIXEL RATE (MHz)	PLL DIVIDER TOTAL PIX/LINE	PLLDIV [11:4] REG 01h [7:0]	PLLDIV [3:0] REG 02h [7:4]	REG 03h	OUTPUT DIVIDER REG 04h [0]	VCO RANGE REG 03h [7:6]	CP CURRENT REG 03h [5:3]
VGA	640 × 480	59.94	31.469	25.175	800	32h	00h	20h	0	ULow (00b)	100b
	640 × 480	72.809	37.861	31.5	832	34h	00h	20h	0	ULow (00b)	100b
	640 × 480	75	37.5	31.5	840	34h	80h	20h	0	ULow (00b)	100b
	640 × 480	85.008	43.269	36	832	34h	00h	60h	0	Low (01b)	100b
SVGA	800 × 600	56.25	35.156	36	1024	40h	00h	58h	0	Low (01b)	011b
	800 × 600	60.317	37.879	40	1056	42h	00h	58h	0	Low (01b)	011b
	800 × 600	72.188	48.077	50	1040	41h	00h	58h	0	Low (01b)	011b
	800 × 600	75	46.875	49.5	1056	42h	00h	58h	0	Low (01b)	011b
	800 × 600	85.061	53.674	56.25	1048	41h	80h	58h	0	Low (01b)	011b
XGA	1024 × 768	60.004	48.363	65	1344	54h	00h	58h	0	Low (01b)	011b
	1024 × 768	70.069	56.476	75	1328	53h	00h	A8h	0	Med (10b)	101b
	1024 × 768	75.029	60.023	78.75	1312	52h	00h	A8h	0	Med (10b)	101b
WXGA (I)	1280 × 768	59.995	47.396	68.25	1440	5Ah	00h	50h	0	Low (01b)	010b
	1280 × 768	59.87	47.776	79.5	1664	68h	00h	A0h	0	Med (10b)	100b
	1280 × 768	74.893	60.289	102.25	1696	6Ah	00h	A0h	0	Med (10b)	100b
	1280 × 768	84.837	68.633	117.5	1712	6Bh	00h	A0h	0	Med (10b)	100b
SXGA	1280 × 1024	60.02	63.981	108	1688	69h	80h	A0h	0	Med (10b)	100b
	1280 × 1024	75.025	79.976	135	1688	69h	80h	E8h	0	High (11b)	101b
	1280 × 1024	85.024	91.146	157.5	1728	6Ch	00h	E8h	0	High (11b)	101b
SXGA+	1400 × 1050	59.948	64.744	101	1560	61h	80h	A0h	0	Med (10b)	100b
	1400 × 1050	59.978	65.317	121.75	1864	74h	80h	98h	0	Med (10b)	011b
	1400 × 1050	74.867	82.278	156	1896	76h	80h	E0h	0	High (11b)	100b
WXGA (II)	1440 × 900	59.901	55.469	88.75	1600	64h	00h	A0h	0	Med (10b)	100b
	1440 × 900	59.887	55.935	106.5	1904	77h	00h	98h	0	Med (10b)	011b
	1440 × 900	74.984	70.635	136.75	1936	79h	00h	E0h	0	High (11b)	100b
	1440 × 900	84.842	80.43	157	1952	7Ah	00h	E0h	0	High (11b)	100b
UXGA	1600 × 1200	60	75	162	2160	87h	00h	E0h	0	High (11b)	100b

**Table 4. Recommended VCO Range and Charge Pump Current Settings for Supporting Standard Display Formats (continued)**

STANDARD	RESOLUTION	FRAME RATE (Hz)	LINE RATE (kHz)	PIXEL RATE (MHz)	PLL DIVIDER TOTAL PIX/LINE	PLLDIV [11:4] REG 01h [7:0]	PLLDIV [3:0] REG 02h [7:4]	REG 03h	OUTPUT DIVIDER REG 04h [0]	VCO RANGE REG 03h [7:6]	CP CURRENT REG 03h [5:3]
Video	720 x 480i	29.97	15.734	13.5	858	35h	A0h	18h	0	ULow (00b)	011b
	720 x 576i	25	15.625	13.5	864	36h	00h	18h	0	ULow (00b)	011b
	720 x 480p	59.94	31.469	27	858	35h	A0h	18h	0	ULow (00b)	011b
	720 x 576p	50	31.25	27	864	36h	00h	18h	0	ULow (00b)	011b
	1280 x 720p	60	45	74.25	1650	67h	20h	A0h	0	Med (10b)	100b
	1280 x 720p	50	37.5	74.25	1980	7Bh	C0h	98h	0	Med (10b)	011b
	1920 x 1080i	30	33.75	74.25	2200	89h	80h	98h	0	Med (10b)	011b
	1920 x 1080i	25	28.125	74.25	2640	A5h	00h	90h	0	Med (10b)	010b
	1920 x 1080p	60	67.5	148.5	2200	89h	80h	E0h	0	High (11b)	100b
1920 x 1080p	50	56.25	148.5	2640	A5h	00h	D8h	0	High (11b)	011b	

### RGB-to-YCbCr Color Space Conversion

The TVP7002 supports RGB-to-YCbCr color space conversion (CSC) with I<sup>2</sup>C programmable coefficients. The TVP7002 should default to the CSC coefficients required for HDTV component video inputs. The TVP7002 supports the ability to bypass the CSC block and defaults to the bypass mode (bit 4 of subaddress 18h).

RGB-to-YCbCr CSC coefficients for HDTV component video (see CEA-770.3-C, ITU-R BT.709) (default coefficients):

	G'	B'	R'
Y	00000016E3	000000024F	00000006CE
Pb	FFFFFFFF3AB	0000001000	FFFFFFFFC55
Pr	FFFFFFFF178	FFFFFFFFE88	0000001000

RGB-to-YCbCr CSC coefficients for SDTV component video (see CEA-770.2-C, ITU-R BT.601) (informative only):

	G'	B'	R'
Y	00000012C9	00000003A6	0000000991
Pb	FFFFFFFF566	0000001000	FFFFFFFFA9A
Pr	FFFFFFFF29A	FFFFFFFFD66	0000001000

### 4:4:4 to 4:2:2 Conversion

For 4:4:4 YPbPr component video inputs, the TVP7002 can downsample the chroma samples (CbCr) from 1x to 0.5x using a 27-tap half-band filter.

#### NOTE

- Selection between the 30-bit 4:4:4 output format and the 20-bit 4:2:2 output format is made using bit 1 of register 15h.
- Multiplexed CbCr data is output on BOUT [9:0] in the 20-bit 4:2:2 output format.
- 4:4:4 to 4:2:2 conversion is implemented after RGB-to-YCbCr color space conversion.

## Sync Processing

### Horizontal Sync Selection

The TVP7002 provides two HSYNC inputs and three analog SOG inputs for HDTV and PC graphics inputs. The sync input used by the horizontal PLL is automatically selected based on activity detection.

### Sync Slicer

TVP7002 includes a circuit that compares the input signal on Green channel to a level 150 mV (typical value) above the clamped level (sync tip). The slicing level is programmable by I<sup>2</sup>C register subaddress at 10h. The digital output of the composite sync slicer is available on the SOGOUT pin.

### Noise Immunity

In general, noise on a slowly varying input signal (i.e., sync falling edge) may cause a voltage comparator to false trigger as the input passes through the linear range of the comparator. To improve the overall performance of the TVP7002 sync slicer in the presence of noise on the SOG input, the voltage comparator includes hysteresis. Maintaining a 50% slice level using the I<sup>2</sup>C programmable slice level control can further improve the noise immunity of the Sync slicer. The slice level is programmable in 11.2-mV increments over a 350-mV range as follows.

$$\text{slice\_level} = (350 \text{ mV}) \times (N_{\text{TH}}/31)$$

$$\text{where } 0 \leq N_{\text{TH}} \leq 31, \text{ default: } 11$$

$$0 \leq \text{slice\_level} \leq 350 \text{ mV}$$

### Glitch Immunity

During white-to-black transitions, the input video waveform may undershoot below the sync slicer threshold. To help attenuate the amplitude of such glitches, a single-pole low-pass filter with three selectable cutoff frequencies (2.5, 10, and 33 MHz) is provided at the input of the SOG voltage comparator circuit. This filter is bypassed in the default mode.

---

#### NOTE

Although the low-pass filter may attenuate the amplitude of glitches present on the SOG input, it also makes the sync falling edge less sharp.

---

### Sync Separator

The sync separator automatically extracts VSYNC and HSYNC from the sliced composite sync input supplied at the SOG input. The G or Y input containing the composite sync must be ac coupled to the SOG input pin using a 1-nF capacitor. Support for PC graphics, SDTV, EDTV, and HDTV up to 1080p is provided. The internal sync separator provides support for formats having field rates (VSYNC frequencies) at or above 40 Hz. An external sync separator or separated VSYNC must be used for field rates less than 40 Hz.

### Sync Activity Detection

The TVP7002 provides activity detection on the sync inputs (VSYNC, HSYNC) to enable the host processor to determine whether the PC graphics source is configured as a 3-wire, 4-wire, or 5-wire interface as defined here:

- 5 wire (G, B, R, HSYNC, VSYNC)
- 4 wire (G, B, R, CSYNC)
- 3 wire (G, B, R with SOG)

If activity is detected on the VSYNC input, the host processor should assume that the PC graphics input is a standard 5-wire interface. In this case, the HSYNC input of the TVP7002 should be configured as an HSYNC input. If AHSO and AVSO are set for automatic selection in I<sup>2</sup>C Reg 0Eh, the TVP7002 will automatically use the HSYNC and VSYNC inputs, provided signals are present at both inputs.

If activity is detected on the HSYNC input but not on the VSYNC input, the host processor should assume that the PC graphics input is a standard 4-wire interface. In this case, the HSYNC input of the TVP7002 should be used as a digital CSYNC input. If AHSO and AVSO are set for automatic selection, VSYNC will be properly decoded from the CSYNC input, provided no signal is present at the VSYNC input pin. Some test sources output CSYNC on both the HSYNC pin and the VSYNC pin. In this case, the active VSYNC source (AVSS) must be manually set to Sync separated VSYNC in Reg 0Eh.

If activity is not detected on either the HSYNC input or the VSYNC input, the host processor should assume that the PC graphics input is a standard 3-wire interface. With AHSO and AVSO set for automatic selection and no signals present at the HSYNC and VSYNC input pins, the TVP7002 will automatically select the SOG input as the sync source.

**Table 5. Sync Activity Detection**

VSYNC INPUT ACTIVITY DETECT	HSYNC INPUT ACTIVITY DETECT	PC GRAPHICS INPUT TYPE
1	1	5 wire (default)
0	1	4 wire
0	0	3 wire

The activity detection status for the VSYNC and HSYNC inputs is written to the I<sup>2</sup>C status register at subaddress 14h.

---

**NOTE**

Pin 13 of a standard 15-pin VGA video connector can be either a horizontal sync (HSYNC) or a composite sync (CSYNC). Automatic HSYNC polarity detection is recommended (Reg 0Eh HSPO=0) for all sync types.

---



---

**NOTE**

For component video inputs, the active HSYNC and VSYNC should always be derived from the selected SOG input. This can most easily be ensured by setting the AHSO, AVSO, AHSS and AVSS bit fields in register 0Eh to logic 1.

---



---

**NOTE**

For proper operation when separate HSYNC and VSYNC inputs are used, the leading edge of VSYNC must not be precisely aligned with the leading edge of HSYNC. A simple RC delay circuit will provide adequate delay in most applications.

---



## Output Formatter

The output formatter sets how the data is formatted for output on the TVP7002 output buses. [Table 6](#) shows the available component video output modes.

**Table 6. YCbCr Component Video Output Formats<sup>(1)</sup>**

TERMINAL NAME	TERMINAL NUMBER	30-BIT 4:2:2 YCbCr	20-BIT 4:2:2 YCbCr
G_9	43	Y9	Y9
G_8	44	Y8	Y8
G_7	45	Y7	Y7
G_6	46	Y6	Y6
G_5	47	Y5	Y5
G_4	48	Y4	Y4
G_3	49	Y3	Y3
G_2	50	Y2	Y2
G_1	51	Y1	Y1
G_0	52	Y0	Y0
B_9	29	Cb9	Cb9, Cr9
B_8	30	Cb8	Cb8, Cr8
B_7	31	Cb7	Cb7, Cr7
B_6	32	Cb6	Cb6, Cr6
B_5	33	Cb5	Cb5, Cr5
B_4	34	Cb4	Cb4, Cr4
B_3	35	Cb3	Cb3, Cr3
B_2	36	Cb2	Cb2, Cr2
B_1	37	Cb1	Cb1, Cr1
B_0	38	Cb0	Cb0, Cr0
R_9	29	Cr9	
R_8	30	Cr8	
R_7	31	Cr7	
R_6	32	Cr6	
R_5	33	Cr5	
R_4	34	Cr4	
R_3	35	Cr3	
R_2	36	Cr2	
R_1	37	Cr1	
R_0	38	Cr0	

(1) 10-bit 4:2:2 YCbCr output format (i.e., ITU-R BT.656) is not supported by the TVP7002.

### NOTE

In the 20-bit 4:2:2 YCbCr output mode, the unused Red outputs (R[9:0]) are placed in a high-impedance state.

## Embedded Syncs

Standard embedded syncs insert SAV and EAV codes into the data stream on the rising and falling edges of AVID. These codes contain the V and F bits that also define vertical timing. [Table 7](#) gives the format of the SAV and EAV codes.

H = 1 always indicates EAV. H = 0 always indicates SAV. The alignment of V and F to the line and field counter varies depending on the standard. The P bits are protection bits:

$$P3 = V \text{ xor } H$$

$$P2 = F \text{ xor } H$$

$$P1 = F \text{ xor } V$$

$$P0 = F \text{ xor } V \text{ xor } H$$

**Table 7. EAV and SAV Sequence**

	Y9 (MSB)	Y8	Y7	Y6	Y5	Y4	Y3	Y2	Y1	Y0
Preamble	1	1	1	1	1	1	1	1	1	1
Preamble	0	0	0	0	0	0	0	0	0	0
Preamble	0	0	0	0	0	0	0	0	0	0
Status	1	F	V	H	P3	P2	P1	P0	0	0

The pixel locations where SAV/EAV embedded sync codes are inserted can be programmed using the AVID Start Pixel and AVID Stop Pixel I<sup>2</sup>C registers. The AVID start location is determined from the HSYNC interval, horizontal back porch interval ( $H_{bp}$ ) and a digital process delay factor ( $P_{DELAY}$ ) required for compensation of internal TVP7002 delays. An additional four bytes must be added to the active pixel interval between AVID start and AVID stop to accommodate embedded sync insertion.

$$\text{AVID Start Pixel} = P_{DELAY} + \text{HSYNC} + H_{bp}$$

$$\text{AVID Stop Pixel} = \text{AVID Start Pixel} + \text{Active Pixels} + 4$$

### NOTE

Some AVID Stop Pixel calculations will exceed the HPLL-Feedback Register setting, or total pixels per line. When this occurs, subtract total pixels per line from AVID Stop Pixel.

### NOTE

$P_{DELAY}$  is typically 27 pixels but may vary slightly depending on other TVP7002 settings such as the Sync-on-Green Threshold setting (I<sup>2</sup>C register 10h) and the SOG LPF setting (I<sup>2</sup>C register 1Ah).

The line numbers where the embedded V-bit and F-bit occur are controlled by I<sup>2</sup>C registers 44h to 49h, which define the vertical blanking interval and field start positions. See [Table 8](#) for typical embedded syncs settings.

**Table 8. Typical Embedded Sync Settings**

Input Format	Output Format REG 15h	AVID Start Pixel		AVID Stop Pixel		VBLK Field 0 Start Line	VBLK Field 1 Start Line	VBLK Field 0 Duration	VBLK Field 1 Duration	F-bit Field 0 Start Line	F-bit Field 1 Start Line
		REG 41h	REG 40h	REG 43h	REG 42h	REG 44h	REG 45h	REG 46h	REG 47h	REG 48h	REG 49h
480i60Hz	47h	00h	95h	00h	0Fh	01h	01h	13h	13h	02h	01h
480p60Hz	47h	00h	93h	00h	0Dh	09h	09h	2Dh	2Dh	00h	00h
720p60Hz	47h	01h	47h	06h	4Bh	05h	05h	1Eh	1Eh	00h	00h
1080i60Hz	47h	01h	07h	08h	8Bh	02h	02h	16h	17h	00h	00h
1080p60Hz	47h	01h	07h	08h	8Bh	04h	04h	2Dh	2Dh	00h	00h

## Output Range Limits

The TVP7002 provides selectable output range limits in I<sup>2</sup>C subaddress 15h:

- 00 = RGB coding range (Y, Cb, and Cr range from 0 to 1023) (default)
- 01 = Extended coding range (Y, Cb, and Cr range from 4 to 1019)
- 10 = ITU-R BT.601 coding range (Y ranges from 64 to 940, Cb and Cr range from 64 to 960)
- 11 = Reserved

---

### NOTE

RGB coding range not allowed with embedded syncs.

---

## Power Management

The TVP7002 supports both automatic and manual power-down modes. The automatic power-down mode can be selected by setting bit 2 of subaddress 0Fh to logic 0.

In the automatic power-down mode, the TVP7002 powers down the ADCs, the ADC reference, and horizontal PLL when activity is not detected on both the selected HSYNC input and the selected SOG input (VSYNC is no longer used). The TVP7002 restores power whenever activity is detected on either the selected HSYNC input or the selected SOG input.

The TVP7002 can also be placed in power-down mode via the active-high PWDN input (pin 70). When the PWDN input is driven high, the TVP7002 powers down everything including the I<sup>2</sup>C interface, and the digital outputs are not placed in a high-impedance mode.

The TVP7002 can also be placed in a power-down mode using bit 1 of register 0Fh.

Individual blocks of the TVP7002 can be independently powered down using register 2Bh.

### Timing

The TVP7002 supports RGB/YCbCr 4:4:4 and YCbCr 4:2:2 modes. Output timing is shown in Figure 6. All timing diagrams are shown for operation with internal PLL clock at phase 0 and HSOUT Output Start = 0. For the 4:2:2 mode, CbCr data output is on the BOUT[9:0] output port.

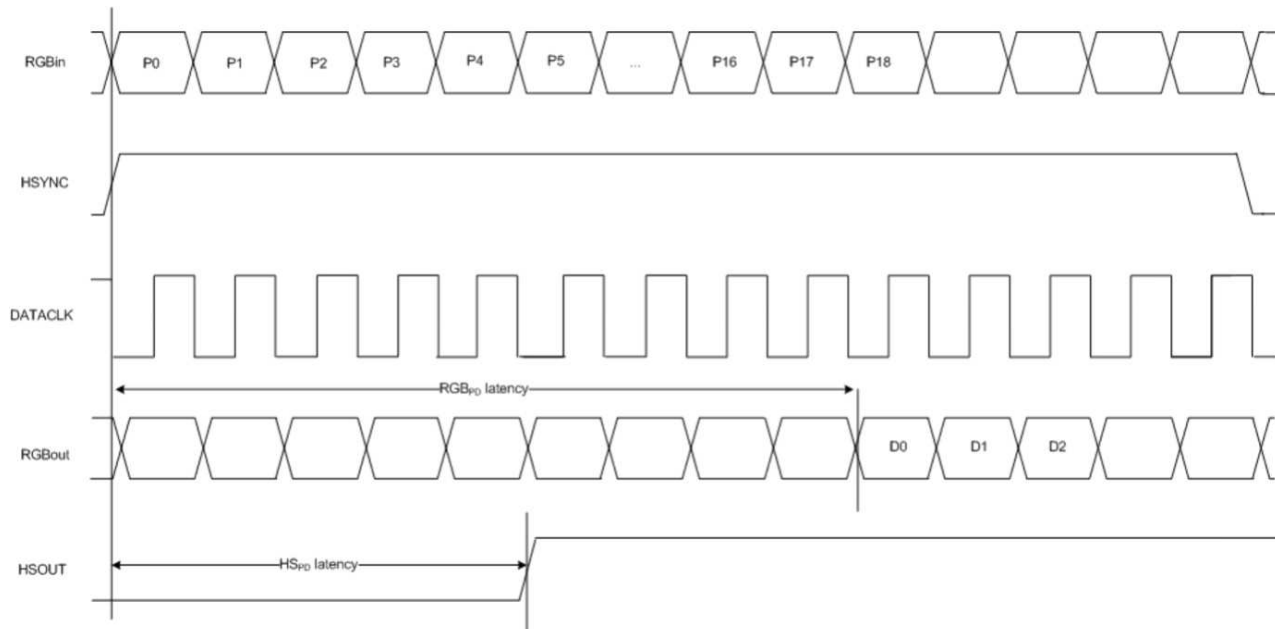

**4:4:4 RGB Output Timing.** RGB output latency ( $RGB_{pd}$ ) is 18 clock cycles. HSOUT latency ( $HS_{pd}$ ) is 5 clock cycles with HS Start set to 0.

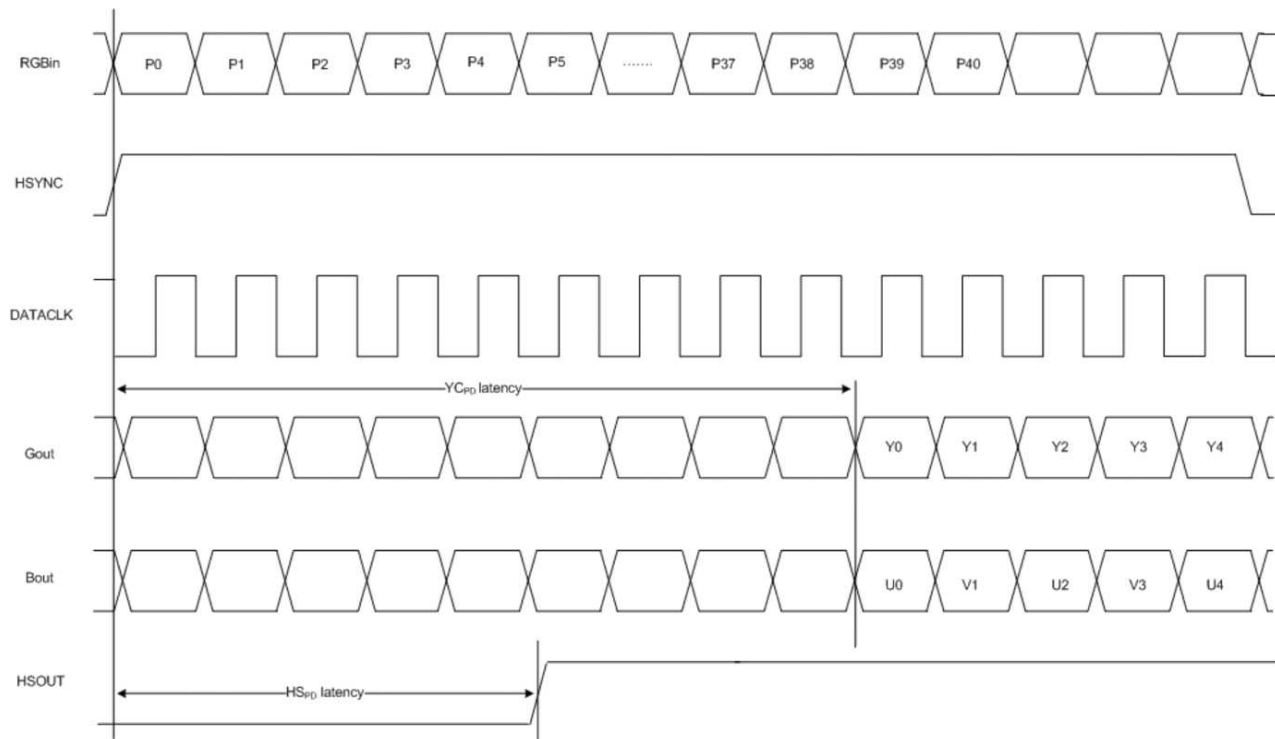

**4:2:2 YCbCr Output Timing.** YCbCr output latency ( $YCr_{pd}$ ) is 39 clock cycles. HSOUT latency ( $HS_{pd}$ ) is 5 clock cycles with HS Start set to 0.

**Figure 6. Output Timing Diagram**

## I<sup>2</sup>C Host Interface

Communication with the TVP7002 device is via an I<sup>2</sup>C host interface. The I<sup>2</sup>C standard consists of two signals, serial input/output data (SDA) line and input clock line (SCL), which carry information between the devices connected to the bus. A third signal (I2CA) is used for slave address selection. Although an I<sup>2</sup>C system can be multi-mastered, the TVP7002 can function as a slave device only.

Since SDA and SCL are kept open drain at logic high output level or when the bus is not driven, the user should connect SDA and SCL to a positive supply voltage via a pullup resistor on the board. SDA is implemented bidirectional. The slave addresses select, terminal 73 (I2CA), enables the use of two TVP7002 devices tied to the same I<sup>2</sup>C bus, as it controls the least significant bit of the I<sup>2</sup>C device address

**Table 9. I<sup>2</sup>C Host Interface Terminal Description**

SIGNAL	TYPE	DESCRIPTION
I2CA	I	Slave address selection
SCL	I	Input clock line
SDA	I/O	Input/output data line

## Reset and I<sup>2</sup>C Bus Address Selection

The TVP7002 can respond to two possible chip addresses. The I<sup>2</sup> slave address is continuously interpreted from the logic level present at the I2CA terminal. The I<sup>2</sup>C slave address must be configured with an external connection to either IOGND (I<sup>2</sup>C address = B8h) or IOVDD (I<sup>2</sup>C address= BAh). A 2.2-kΩ pullup or pulldown resistor may be used for this connection.

**Table 10. I<sup>2</sup>C Host Interface Device Addresses**

A6	A5	A4	A3	A2	A1	A0 (I2CA)	R/W	HEX
1	0	1	1	1	0	0 <sup>(1)</sup>	1/0	B9h/B8h
1	0	1	1	1	0	1 <sup>(2)</sup>	1/0	BBh/BAh

(1) If I2CA terminal 73 is strapped to IOGND, I<sup>2</sup>C device address A0 is set to 0.

(2) If I2CA terminal 73 is strapped to IOVDD, I<sup>2</sup>C device address A0 is set to 1.

## I<sup>2</sup>C Operation

Data transfers occur utilizing the following illustrated formats.

S	10111000	ACK	Subaddress	ACK	Send data	ACK	P
---	----------	-----	------------	-----	-----------	-----	---

Read from I<sup>2</sup>C control registers

S	10111000	ACK	Subaddress	ACK	S	10111001	ACK	Receive data	NAK	P
---	----------	-----	------------	-----	---	----------	-----	--------------	-----	---

S = I<sup>2</sup>C bus Start condition

P = I<sup>2</sup>C bus Stop condition

ACK = Acknowledge generated by the slave

NAK = Acknowledge generated by the master, for multiple byte read master with ACK each byte except last byte

Subaddress = Subaddress byte

Data = Data byte, if more than one byte of DATA is transmitted (read and write), the subaddress pointer is automatically incremented

I<sup>2</sup>C bus address = Example shown that I2CA is in default mode; write (B8h), read (B9h).

### Power Up, Reset, and Initialization

No specific power-up sequence is required, but all power supplies should be active and stable within 500 ms of each other. RESETB may be low during power up, but must remain low for at least 1  $\mu$ s after the power supplies become stable. Alternatively, reset may be asserted any time with minimum 5-ms delay after power-up and must remain asserted for at least 1  $\mu$ s. Reset timing is shown in Figure 7. I<sup>2</sup>C SCL and SDA signals must not change state until the TVP7002 reset sequence has been completed. Keeping RESETB low prior to any I<sup>2</sup>C activity will prevent this. Table 11 shows the status of the TVP7002 terminals during and immediately after reset.

**Table 11. Output Mode Per Reset Sequence State**

SIGNAL NAME	OUTPUT MODE	
	DURING RESET	RESET COMPLETED
R[9:0], B[9:0], G[9:0]	High impedance	Default condition (see bit 0 of subaddress 17h)
HSOUT, VSOUT, FIDOUT, DATACLK	High impedance	Default condition (see bit 0 of subaddress 17h)
SOGOUT	High impedance	Default condition (see bit 1 of subaddress 17h)

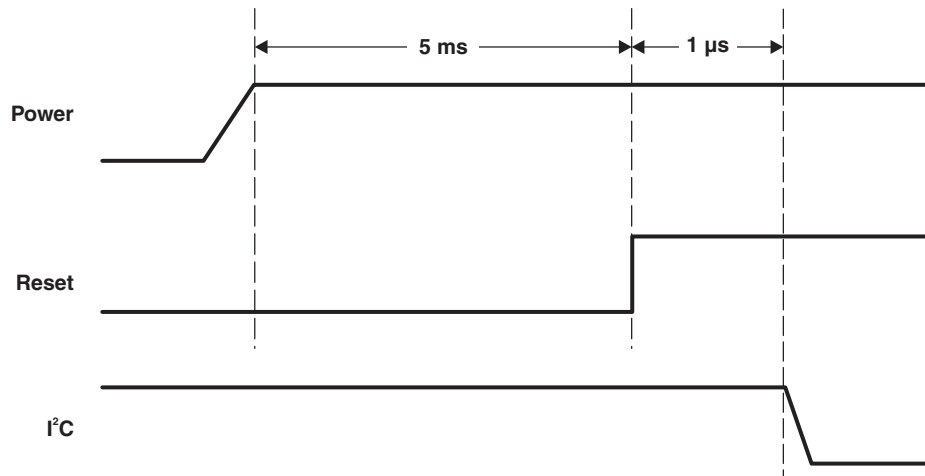

**Figure 7. Reset Timing**

## CONTROL REGISTERS

The TVP7002 is initialized and controlled by a set of internal registers that define the operating parameters of the entire device. Communication between the external controller and the TVP7002 is through a standard I<sup>2</sup>C host port interface, as previously described.

Table 12 shows the summary of these registers. Detailed programming information for each register is described in the following sections.

**Table 12. Control Registers Summary<sup>(1) (2)</sup>**

REGISTER NAME	I <sup>2</sup> C SUBADDRESS	DEFAULT	R/W <sup>(3)</sup>
Chip Revision	00h	02h	R
H-PLL Feedback Divider MSBs	01h	67h	R/W
H-PLL Feedback Divider LSBs	02h	20h	R/W
H-PLL Control	03h	A8h	R/W
H-PLL Phase Select	04h	80h	R/W
Clamp Start	05h	32h	R/W
Clamp Width	06h	20h	R/W
HSYNC Output Width	07h	20h	R/W
Blue Fine Gain	08h	00h	R/W
Green Fine Gain	09h	00h	R/W
Red Fine Gain	0Ah	00h	R/W
Blue Fine Offset MSBs	0Bh	80h	R/W
Green Fine Offset MSBs	0Ch	80h	R/W
Red Fine Offset MSBs	0Dh	80h	R/W
Sync Control 1	0Eh	5Bh	R/W
H-PLL and Clamp Control	0Fh	2Eh	R/W
Sync On Green Threshold	10h	5Dh	R/W
Sync Separator Threshold	11h	20h	R/W
H-PLL Pre-Coast	12h	00h	R/W
H-PLL Post-Coast	13h	00h	R/W
Sync Detect Status	14h		R
Output Formatter	15h	04h	R/W
MISC Control 1	16h	11h	R/W
MISC Control 2	17h	03h	R/W
MISC Control 3	18h	00h	R/W
Input Mux Select 1	19h	00h	R/W
Input Mux Select 2	1Ah	C2h	R/W
Blue and Green Coarse Gain	1Bh	77h	R/W
Red Coarse Gain	1Ch	07h	R/W
Fine Offset LSBs	1Dh	00h	R/W
Blue Coarse Offset	1Eh	10h	R/W
Green Coarse Offset	1Fh	10h	R/W
Red Coarse Offset	20h	10h	R/W
HSOUT Output Start	21h	0Dh	R/W
MISC Control 4	22h	08h	R/W
Blue Digital ALC Output LSBs	23h		R
Green Digital ALC Output LSBs	24h		R

(1) For proper operation of the TVP7002 device, the default settings for all register locations designated as "Reserved" in the register map summary should never be changed from the values provided.

(2) For registers with reserved bits, a 0b must be written to reserved bit locations, unless otherwise stated.

(3) R = Read only, W = Write only, R/W = Read/Write

**Table 12. Control Registers Summary<sup>(1) (2)</sup> (continued)**

REGISTER NAME	I <sup>2</sup> C SUBADDRESS	DEFAULT	R/W <sup>(3)</sup>
Red Digital ALC Output LSBs	25h		R
Automatic Level Control Enable	26h	80h	R/W
Digital ALC Output MSBs	27h		R
Automatic Level Control Filter	28h	53h	R/W
Reserved	29h	08h	R/W
Fine Clamp Control	2Ah	07h	R/W
Power Control	2Bh	00h	R/W
ADC Setup	2Ch	50h	R/W
Coarse Clamp Control	2Dh	00h	R/W
SOG Clamp	2Eh	80h	R/W
RGB Coarse Clamp Control	2Fh	8Ch	R/W
SOG Coarse Clamp Control	30h	04h	R/W
ALC Placement	31h	5Ah	R/W
Reserved	32h	18h	R/W
Reserved	33h	60h	R/W
Macrovision Stripper Width	34h	03h	R/W
VSYNC Alignment	35h	10h	R/W
Sync Bypass	36h	00h	R/W
Lines Per Frame Status	37h–38h		R
Clocks Per Line Status	39h–3Ah		R
HSYNC Width	3Bh		R
VSYNC Width	3Ch		R
Line Length Tolerance	3Dh	03h	R/W
Reserved	3Eh	04h	R/W
Video Bandwidth Control	3Fh	00h	R/W
AVID Start Pixel	40h–41h	012Ch	R/W
AVID Stop Pixel	42h–43h	062Ch	R/W
VBLK Field 0 Start Line Offset	44h	05h	R/W
VBLK Field 1 Start Line Offset	45h	05h	R/W
VBLK Field 0 Duration	46h	1Eh	R/W
VBLK Field 1 Duration	47h	1Eh	R/W
F-bit Field 0 Start Line Offset	48h	00h	R/W
F-bit Field 1 Start Line Offset	49h	00h	R/W
1st CSC Coefficient	4Ah–4Bh	16E3h	R/W
2nd CSC Coefficient	4Ch–4Dh	024Fh	R/W
3rd CSC Coefficient	4Eh–4Fh	06CEh	R/W
4th CSC Coefficient	50h–51h	F3ABh	R/W
5th CSC Coefficient	52h–53h	1000h	R/W
6th CSC Coefficient	54h–55h	FC55h	R/W
7th CSC Coefficient	56h–57h	F178h	R/W
8th CSC Coefficient	58h–59h	FE88h	R/W
9th CSC Coefficient	5Ah–5Bh	1000h	R/W
Reserved	5Ch–5Dh	0000h	R/W
Reserved	5Eh–FFh	0000h	R/W

## Register Definitions

### Chip Revision

Subaddress	00h							Read Only
7	6	5	4	3	2	1	0	
Chip revision [7:0]								

Chip revision [7:0]: Chip revision number

### H-PLL Feedback Divider MSBs

Subaddress	01h							Default (67h)
7	6	5	4	3	2	1	0	
PLL divide [11:4]								

PLL divide [11:0]: Controls the 12-bit horizontal PLL feedback divider value that determines the number of pixels per line. PLL divide [11:4] bits should be loaded first whenever a change is required.

### H-PLL Feedback Divider LSBs

Subaddress	02h							Default (20h)
7	6	5	4	3	2	1	0	
PLL divide [3:0]				Reserved				

PLL divide [11:0]: Controls the 12-bit horizontal PLL feedback divider value that determines the number of pixels per line. PLL divide [11:4] bits should be loaded first whenever a change is required.

### H-PLL Control

Subaddress	03h							Default (A8h)
7	6	5	4	3	2	1	0	
VCO [1:0]		Charge Pump Current [2:0]			Reserved			

VCO [1:0]: Selects VCO frequency range

	VCO Gain ( $K_{VCO}$ )	VCO Range	Pixel Clock Frequency (PCLK)
00 =	75	Ultra low	$PCLK < 36 \text{ MHz}$
01 =	85	Low	$36 \text{ MHz} \leq PCLK < 70 \text{ MHz}$
10 =	150	Medium (default)	$70 \text{ MHz} \leq PCLK < 135 \text{ MHz}$
11 =	200	High	$135 \text{ MHz} \leq PCLK \leq 165 \text{ MHz}$

Charge Pump Current [2:0]: Selects PLL charge pump current setting. The recommended charge pump current setting (ICP) can be determined using the following equation.

$$I_{CP} = 40 \times K_{VCO} / (\text{pixels per line})$$

000 =	0: Small
101 =	5 (default)
111 =	7: Large

NOTE: Also see the PLL and CLAMP Control register at subaddress 0Fh.

## H-PLL Phase Select

Subaddress		04h						Default (80h)
7	6	5	4	3	2	1	0	
Phase Select [4:0]					Reserved		DIV2	

Phase Select [4:0]: ADC sampling clock phase select. (1 LSB =  $360/32 = 11.25^\circ$ ). A host-based automatic phase control algorithm can be used to control this setting to optimize graphics sampling phase.

00h = 0 degrees

10h = 180 degrees (default)

1Fh = 348.75 degrees

DIV2: DATACLK divide-by-2. H-PLL post divider. May be used with a 2x H-PLL feedback divider to improve jitter at low frequencies. When used, only half of the Phase Select [4:0] settings are functional.

0 = DATACLK/1 (default)

1 = DATACLK/2

## Clamp Start

Subaddress		05h						Default (32h)
7	6	5	4	3	2	1	0	
Clamp Start [7:0]								

Clamp Start [7:0]: Positions the clamp signal an integer number of clock periods after the HSYNC signal. If external clamping is selected this value has no meaning. Clamp Start must be correctly positioned for proper operation. See [Table 13](#) for the recommended settings.

## Clamp Width

Subaddress		06h						Default (20h)
7	6	5	4	3	2	1	0	
Clamp Width [7:0]								

Clamp Width [7:0]: Sets the width in pixels for the fine clamp. See also register Clamp Start (subaddress 05h).

**Table 13. Recommended Fine Clamp Settings**

VIDEO STANDARD	CLAMP START	CLAMP WIDTH
HDTV (tri-level)	50 (32h)	32 (20h)
SDTV (bi-level)	6 (06h)	16 (10h)
PC graphics	6 (06h)	16 (10h)

## HSYNC Output Width

Subaddress		07h						Default (20h)
7	6	5	4	3	2	1	0	
HSOUT Width [7:0]								

HSOUT Width [7:0]: Sets the width in pixels for HSYNC output.

## Blue Fine Gain

Subaddress		08h						Default (00h)
7	6	5	4	3	2	1	0	
Blue Fine Gain [7:0]								

Blue Fine Gain [7:0]: 8-bit fine digital gain (contrast) for Blue channel (applied after the ADC). Offset binary value.

Blue Fine Gain = 1 + Blue Fine Gain [7:0]/256

Blue Fine Gain [7:0]	Blue Fine Gain
00h	1.0 (default)
80h	1.5
FFh	2.0

### Green Fine Gain

Subaddress	09h							Default (00h)
7	6	5	4	3	2	1	0	
Green Fine Gain [7:0]								

Green Fine Gain [7:0]: 8-bit fine digital gain (contrast) for Green channel (applied after the ADC). Offset binary value.

Green Fine Gain = 1 + Green Fine Gain [7:0]/256

Green Fine Gain [7:0]	Green Fine Gain
00h	1.0 (default)
80h	1.5
FFh	2.0

### Red Fine Gain

Subaddress	0Ah							Default (00h)
7	6	5	4	3	2	1	0	
Red Fine Gain [7:0]								

Red Fine Gain [7:0]: 8-bit fine digital gain (contrast) for Red channel (applied after the ADC). Offset binary value.

Red Fine Gain = 1 + Red Fine Gain [7:0]/256

Red Fine Gain [7:0]	Red Fine Gain
00h	1.0 (default)
80h	1.5
FFh	2.0

### Blue Fine Offset MSBs

Subaddress	0Bh							Default (80h)
7	6	5	4	3	2	1	0	
Blue Fine Offset [9:2]								

Blue Fine Offset [9:2]: Eight MSBs of 10-bit fine digital offset (brightness) for Blue channel (applied after ADC). Corresponding two LSBs located at register 1Dh. Offset binary value.

The default setting of 80h places the bottom-level (RGB) clamped output blank levels at 0 and mid-level clamped (PbPr) output blank levels at 512.

FFh =	Maximum fine offset
81h =	1 LSB
80h =	0 (default)
7Fh =	-1 LSB
00h =	Minimum fine offset

### Green Fine Offset MSBs

Subaddress	0Ch							Default (80h)
7	6	5	4	3	2	1	0	
Green Fine Offset [9:2]								

Green Fine Offset [9:2]: Eight MSBs of 10-bit fine digital offset (brightness) for Green channel (applied after ADC). Corresponding two LSBs located at register 1Dh. Offset binary value.

The default setting of 80h places the bottom-level (RGB) clamped output blank levels at 0 and mid-level clamped (PbPr) output blank levels at 512.

FFh =	Maximum fine offset
81h =	1 LSB
80h =	0 (default)
7Fh =	-1 LSB
00h =	Minimum fine offset

## Red Fine Offset MSBs

Subaddress	0Dh							Default (80h)
7	6	5	4	3	2	1	0	
Red Fine Offset [9:2]								

Red Fine Offset [9:2]: 8 MSBs of 10-bit fine digital offset (brightness) for Red channel (applied after ADC). Corresponding two LSBs located at register 1Dh. Offset binary value.

The default setting of 80h places the bottom-level (RGB) clamped output blank levels at 0 and mid-level clamped (PbPr) output blank levels at 512.

- FFh = Maximum fine offset
- 81h = 1 LSB
- 80h = 0 (default)
- 7Fh = -1 LSB
- 00h = Minimum fine offset

## Sync Control 1

Subaddress	0Eh							Default (5Bh)
7	6	5	4	3	2	1	0	
HSPO	HSIP	HSOP	AHSO	AHSS	VSOP	AVSO	AVSS	

HSPO: HSYNC polarity override

- 0 = Polarity determined by chip (default)
- 1 = Polarity set by bit 6 in register 0Eh (not recommended)

HSIP: HSYNC input polarity

- 0 = Indicates input HSYNC polarity active low
- 1 = Indicates input HSYNC polarity active high (default)

HSOP: HSYNC output polarity

- 0 = Active-low HSYNC output (default)
- 1 = Active-high HSYNC output

NOTE: HSOP has no effect in raw sync bypass mode. See register 36h.

AHSO: Active HSYNC override

- 0 = Active HSYNC is automatically selected by TVP7002. If selected, SOG and HSYNC inputs both have active inputs, HSYNC is selected as the active sync source. The selected active HSYNC is provided via the AHS status bit (bit 6 of register 14h).
- 1 = Active HSYNC is manually selected via the AHSS control bit (bit 3 of register 0Eh). (default)

NOTE: Automatic sync selection should be enabled only for 5-wire PC graphics inputs.

AHSS: Active HSYNC select. The indicated HSYNC is used only if the AHSO control bit (bit 4) is set to 1 or if activity is detected on both the selected HSYNC input and the selected SOG input (bits 1, 7 = 1 in register 14h).

- 0 = Active HSYNC is derived from the selected HSYNC input.
- 1 = Active HSYNC is derived from the selected SOG input (default).

VSOP: VSYNC output polarity

- 0 = Active-low VSYNC output (default)
- 1 = Active-high VSYNC output

AVSO: Active VSYNC override

- 0 = Active VSYNC is automatically selected by TVP7002. If selected, SOG and VSYNC inputs both have active inputs, VSYNC is selected as the active sync source. The selected active VSYNC is provided via the AVS status bit (bit 3 of register 14h).
- 1 = Active VSYNC is manually selected via the AVSS control bit (bit 0 of register 0Eh) (default).

NOTE: Automatic sync selection should be enabled only for 5-wire PC graphics inputs.

AVSS: Active VSYNC select. This bit is effective when the AVSO control bit (bit 1) is set to 1.

- 0 = Active VSYNC is derived from the selected VSYNC input.
- 1 = Active VSYNC is derived from the Sync separated VSYNC (default).

## H-PLL and Clamp Control

Subaddress 0Fh							Default (2Eh)
7	6	5	4	3	2	1	0
CF	CP	Coast Sel	CPO	CPC	SMO	FCPD	ADC Test

CF: Clamp Function. Clamp pulse select. This control bit determines whether the timing for both the fine clamp and the ALC circuit are generated internally or externally.

- 0 = Internal fine clamp and ALC timing (default)
- 1 = External fine clamp and ALC timing (pin 76)

CP: Clamp Polarity. External clamp polarity select

- 0 = Active-high clamp pulse (default)
- 1 = Active-low clamp pulse

CS: Coast Select. Coast signal select. This control bit determines whether the timing for H-PLL coast signal is generated internally or externally.

- 0 = External H-PLL coast timing (pin 77)
- 1 = Internal H-PLL coast timing (default)

CPO: Coast Polarity Override

- 0 = Polarity determined by chip (default)
- 1 = Polarity set by Bit 3 in register 0Fh

CPC: Coast Polarity Change. External coast polarity select

- 0 = Active-low coast signal
- 1 = Active-high coast signal (default)

SMO: Seek Mode Override. Places the TVP7002 in a low power mode whenever no activity is detected on the selected sync inputs.

- 0 = Enable automatic power management mode
- 1 = Disable automatic power management mode (default)

NOTE: Digital outputs are not high impedance and may be in a random state during low power mode. Outputs can be put in high impedance state by I<sup>2</sup>C register 17h.

FCPD: Full Chip Power Down. Active-low power down. FCPD powers down all blocks except I<sup>2</sup>C. The I<sup>2</sup>C register values are retained.

- 0 = Power-down mode
- 1 = Normal operation (default)

NOTE: Digital outputs are not high impedance and may be in random state during FCPD. Outputs can be put in high impedance state by I<sup>2</sup>C register 17h.

ADC Test: Active-high ADC test mode select. When placed in the ADC test mode, the TVP7002 disables the fine clamp, enables the coarse clamp, and selects the external clock input (pin 80) for each ADC channel.

- 0 = ADC test mode disabled (default)
- 1 = ADC test mode enabled

NOTE: Also see the Horizontal PLL Control register at subaddress 03h.

## Sync-On-Green Threshold

Subaddress 10h							Default (5Dh)
7	6	5	4	3	2	1	0
SOG Threshold [4:0]					Blue CS	Green CS	Red CS

SOG Threshold [4:0]: Sets the voltage level of the SOG slicer comparator according to the following equation.

$$\text{slice\_level} = (350 \text{ mV}) \times (N_{TH}/31)$$

$$00h = 0 \text{ mV}$$

$$0Bh = 124 \text{ mV (default)}$$

$$1Fh = 350 \text{ mV}$$

Blue Clamp Select: This bit has no effect when the Blue channel fine clamp is disabled (bit 2 of subaddress 2Ah).

0 = Bottom-level fine clamp

1 = Mid-level fine clamp (default)

Green Clamp Select: This bit has no effect when the Green channel fine clamp is disabled (bit 1 of subaddress 2Ah).

0 = Bottom-level fine clamp (default)

1 = Mid level fine clamp

Red Clamp Select: This bit has no effect when the Red channel fine clamp is disabled (bit 0 of subaddress 2Ah).

0 = Bottom-level fine clamp

1 = Mid-level fine clamp (default)

NOTE: Bottom-level clamping is required for Y and RGB inputs, while mid-level clamping is required for Pb and Pr inputs. The internal clamp pulse must also be correctly positioned for proper clamp operation (see register 05h)

## Sync Separator Threshold

Subaddress 11h							Default (20h)
7	6	5	4	3	2	1	0
Sync Separator Threshold [7:0]							

Sync Separator Threshold [7:0]: Sets how many internal clock reference periods the sync separator counts to before toggling high or low. Sync Separator Threshold [7:0] × (minimum clock period) must be greater than the width of the negative sync pulse. This setting can also affect the position of the VSOUT (see register 22h).

NOTE: The internal clock reference is typically 6.5 MHz, but a minimum clock period of 133 ns is recommended to allow for clock variation.

40h = recommended setting for support of most video formats

NOTE: Margin for a particular format can be maximized by using a mid-range setting below.

Format	MIN	MID	MAX
480i60Hz	1Fh	75h	ABh
480p60Hz	10h	64h	BAh
576i50Hz	20h	75h	ACh
576p50Hz	11h	64h	BCh
720p60Hz	1Bh	43h	6Ch
720p50Hz	37h	50h	6Ch
1080i60Hz	0Eh	2Ch	4Bh
1080i50Hz	21h	36h	4Bh
1080p60Hz	08h	2Dh	53h
1080p50Hz	1Bh	36h	53h

## H-PLL Pre-Coast

Subaddress 12h							Default (00h)
7	6	5	4	3	2	1	0
Pre-Coast [7:0]							

Pre-Coast [7:0]: Sets the number of HSYNC periods that coast becomes active prior to VSYNC leading edge. A minimum setting of 1 is required to guarantee generation of an internal coast signal.

## H-PLL Post-Coast

Subaddress							13h	Default (00h)
7	6	5	4	3	2	1	0	
Post-Coast [7:0]								

Post-Coast [7:0]: Sets the number of HSYNC periods that coast stays active following VSYNC trailing edge. Post-Coast settings must be extended to include Macrovision™ pseudo syncs when Macrovision is present.

**Table 14. Recommended H-PLL Pre-Coast and H-PLL Post-Coast Settings**

STANDARD	H-PLL PRE-COAST	H-PLL POST-COAST
480i/p	3	3
576i/p	3	3
1080i	1	0
1080p	1	0
720p	1	0
PC SOG Graphics	1	0

## Sync Detect Status

Subaddress							14h	Read Only
7	6	5	4	3	2	1	0	
HSD	AHS	IHSPD	VSD	AVS	VSPD	SOGD	ICPD	

HSD: HSYNC Detect. HSYNC activity detection for selected HSYNC input (pin 81 or 82).

- 0 = No HSYNC activity detected
- 1 = HSYNC activity detected

AHS: Active HSYNC. Indicates whether the active HSYNC is derived from the selected HSYNC input or the selected SOG input.

- 0 = HSYNC from selected HSYNC input (pin 81 or 82)
- 1 = HSYNC from selected SOG input (pin 1, 99, or 97)

IHSPD: Input HSYNC Polarity Detect. HSYNC polarity detection for selected HSYNC input (pin 81 or 82).

- 0 = Active-low HSYNC
- 1 = Active-high HSYNC

VSD: VSYNC Detect. VSYNC activity detection for selected VSYNC input (pin 78 or 79).

- 0 = No VSYNC activity detected
- 1 = VSYNC activity detected

AVS: Active VSYNC. Indicates whether the active VSYNC is derived from the selected VSYNC input or the sync separator.

- 0 = VSYNC from selected VSYNC input (pin 78 or 79)
- 1 = VSYNC from sync separator

VSPD: Input VSYNC Polarity Detect. VSYNC polarity detection for selected VSYNC input (pin 78 or 79).

- 0 = Active-low VSYNC
- 1 = Active-high VSYNC

SOGD: SOG Detect. SOG activity detection for selected SOG input (pin 1, 99, or 97).

- 0 = No SOG activity detected
- 1 = SOG activity detected

ICPD: Input Coast Polarity Detect. Coast signal polarity detection.

- 0 = Active-low coast signal
- 1 = Active-high coast signal

## Output Formatter

Subaddress 15h							Default (04h)
7	6	5	4	3	2	1	0
Reserved	Output code range [1:0]		Reserved	Clamp REF	CbCr order	422/444	Sync En

Reserved [7]:

0 = Required (default)

Output code range [1:0]:

00 = RGB coding range (Y, Cb, and Cr range from 0 to 1023) (default)

01 = Extended coding range (Y, Cb, and Cr range from 4 to 1019)

10 = ITU-R BT.601 coding range (Y ranges from 64 to 940, Cb and Cr range from 64 to 960)

11 = Reserved

Reserved [4]:

0 = Required (default)

Clamp REF: Selects which edge of HSYNC is used as the timing reference for the fine clamp pulse placement and also the ALC placement.

0 = Clamp pulse placement referred to the trailing edge of HSYNC (default)

1 = Clamp pulse placement referred to the leading edge of HSYNC

CbCr order: This bit is only effective in the 4:2:2 output mode (i.e., bit 1 is set to 1).

0 = CbCr order

1 = CrCb order (default)

422/444: Active-high 4:4:4 to 4:2:2 decimation filter enable

0 = 30-bit 4:4:4 output format (default)

1 = 20-bit 4:2:2 output format

Notes:

1. Multiplexed CbCr data is output on BOUT [9:0] in the 20-bit 4:2:2 output format.

2. 10-bit 4:2:2 output format is not supported.

Sync En: Active-high embedded sync enable

0 = Embedded sync disabled (default)

1 = Embedded sync enabled

Notes:

1. Embedded syncs are not supported when the RGB coding range (0 to 1023) is selected.

2. Embedded syncs are not supported when the 30-bit 4:4:4 output format is selected.

3. Discrete syncs are always enabled except when outputs are placed in the high-impedance mode.

4. When enabled, embedded syncs are present in both the Y and C outputs.

## MISC Control 1

Subaddress 16h							Default (11h)
7	6	5	4	3	2	1	0
Reserved			CbCr Align	Reserved		PLL PD	STRTB

CbCr Align: CbCr alignment

0 = Alternative operation

1 = Normal operation (default)

PLL PD: Active-high H-PLL power down

0 = Normal operation (default)

1 = H-PLL powered down

STRTB: Active-high H-PLL start-up circuit enable

0 = H-PLL start-up circuit disabled

1 = H-PLL start-up circuit enabled (default)

## MISC Control 2

Subaddress 17h							Default (03h)
7	6	5	4	3	2	1	0
Reserved	Test output control [2:0]			Reserved		SOG En	Output En

Test output control [2:0]: Selects which signal is output on pin 22. Output polarity control is also provided using bit 2 of subaddress 18h.

- 000 = Field ID output (default)
- 001 = Data Enable output
- 010 = Reserved
- 011 = Reserved
- 100 = Internal clock reference output (~6.5 MHz typical)
- 101 = Coast output
- 110 = Clamp pulse output
- 111 = High-impedance mode

SOG En: Active-low output enable for SOGOUT output.

- 0 = SOG output enabled
- 1 = SOG output placed in high-impedance mode (default)

Output En: Active-low output enable for RGB, DATACLK, HSOUT, VSOUT, and FIDOUT outputs. This control bit allows selecting a high-impedance output mode for multiplexing the output of the TVP7002 with another device.

- 0 = Outputs enabled
- 1 = Outputs placed in high-impedance mode (default)

NOTE: Data Enable output is equivalent to the internal active video signal that is controlled by the AVID start/stop pixel values and the VBLK offset/duration line values.

## MISC Control 3

Subaddress 18h							Default (00h)
7	6	5	4	3	2	1	0
Reserved	Reserved	Blank En	CSC En	Reserved	FID POL	SOG POL	CLK POL

Reserved [7]:

- 0 = Required (default)

Blank En: Active-high blank level enable. Forces the video blank level to a standard value when using embedded syncs.

- 0 = Normal operation (default)
- 1 = Force standard blank levels

CSC En: Active-high CSC enable. When disabled, the CSC block is bypassed.

- 0 = CSC disabled (default)
- 1 = CSC enabled

FID POL: Active-high Field ID output polarity control. Under normal operation, the field ID output is set to logic 1 for an odd field (field 1) and set to logic 0 for an even field (field 0).

- 0 = Normal operation (default)
- 1 = FID output polarity inverted

NOTE: This control bit also affects the polarity of the data enable output when selected (see Test output control [2:0] at subaddress 17h).

SOG POL: Active-high SOG output polarity control

- 0 = Normal operation (default)
- 1 = SOG output polarity inverted

CLK POL: Allows selecting the polarity of the output data clock.

- 0 = Data is clocked out on rising edge of DATACLK (default)
- 1 = Data is clocked out on falling edge of DATACLK

## Input Mux Select 1

Subaddress		19h		Default (00h)			
7	6	5	4	3	2	1	0
SOG Select [1:0]		Red Select [1:0]		Green Select [1:0]		Blue Select [1:0]	

SOG Select [1:0]: Selects one of three SOG inputs.

- 00 = SOGIN\_1 input selected (default)
- 01 = SOGIN\_2 input selected
- 10 = SOGIN\_3 input selected
- 11 = Reserved

Red Select [1:0]: Selects one of three R/Pr inputs.

- 00 = RIN\_1 input selected (default)
- 01 = RIN\_2 input selected
- 10 = RIN\_3 input selected
- 11 = Reserved

Green Select [1:0]: Selects one of four G/Y inputs.

- 00 = GIN\_1 input selected (default)
- 01 = GIN\_2 input selected
- 10 = GIN\_3 input selected
- 11 = GIN\_4 input selected

Blue Select [1:0]: Selects one of three B/Pb inputs.

- 00 = BIN\_1 input selected (default)
- 01 = BIN\_2 input selected
- 10 = BIN\_3 input selected
- 11 = Reserved

## Input Mux Select 2

Subaddress 1Ah							Default (C2h)
7	6	5	4	3	2	1	0
SOG LPF SEL [1:0]		CLP LPF SEL [1:0]		CLK SEL	VS SEL	PCLK SEL	HS SEL

SOG LPF SEL [1:0]: SOG low-pass filter selection. The SOG low-pass filter can be used to attenuate glitches present on the SOG input. Excessive filtering can lead to sync detection issues and increased sample clock jitter.

- 00 = 2.5-MHz low-pass filter
- 01 = 10-MHz low-pass filter
- 10 = 33-MHz low-pass filter
- 11 = Low-pass filter bypass (default)

CLP LPF SEL [1:0]: Coarse clamp low-pass filter selection. This filter effects the operation of all enabled coarse clamps which is generally the SOG coarse clamp only.

- 00 = 4.8-MHz low-pass filter (default). Suitable for HDTV and graphics formats.
- 01 = 0.5-MHz low-pass filter. Suitable for SDTV formats.
- 10 = 1.7-MHz low-pass filter
- 11 = Reserved

CLK SEL: Clock reference select for Sync Processing block. The internal reference clock is typically 6.5 MHz, but it should not be considered a precise clock. An external 27-MHz reference clock is therefore recommended for accurate mode detection. NOTE: The I<sup>2</sup>C interface, Sync Separator, and activity detection circuitry always uses the internal clock reference.

- 0 = Internal clock reference (default)
- 1 = External clock reference (EXT\_CLK)

NOTE: The external clock input can also be selected as the sample clock for the ADCs (see bit 1).

VS SEL: VSYNC input select

- 0 = VSYNC\_A input selected (default)
- 1 = VSYNC\_B input selected

PCLK SEL: Pixel clock selection. When the external clock input (pin 80) is selected as the ADC sample clock, the external clamp pulse (pin 76) should also be selected (Bit 7 of subaddress 0Fh).

- 0 = ADC samples data using external clock input (pin 80)
- 1 = ADC samples data using H-PLL generated clock (default)

NOTE: The external clock input can also be selected as the reference clock for the Sync Processing block (see bit 3).

HS SEL: HSYNC input select

- 0 = HSYNC\_A input selected (default)
- 1 = HSYNC\_B input selected

NOTE: See the Sync Control register at subaddress 0Eh.

## Blue and Green Coarse Gain

Subaddress		1Bh						Default (77h)
7	6	5	4	3	2	1	0	
Green Coarse Gain [3:0]				Blue Coarse Gain [3:0]				

Green Coarse Gain [3:0]: 4-bit coarse analog gain for Green channel (applied before the ADC). To avoid clipping at the ADC,  $V_{P,P}$  in X Gain must be less than  $1 V_{P,P}$ .

Gain [3:0]	Description
0000	= 0.5
0001	= 0.6
0010	= 0.7
0011	= 0.8
0100	= 0.9
0101	= 1.0
0110	= 1.1
0111	= 1.2
1000	= 1.3
1001	= 1.4
1010	= 1.5
1011	= 1.6
1100	= 1.7
1101	= 1.8
1110	= 1.9
1111	= 2.0

Default  
Maximum recommended gain for 700 mV<sub>P,P</sub> input

Blue Coarse Gain [3:0]: 4-bit coarse analog gain for Blue channel (applied before the ADC).

## Red Coarse Gain

Subaddress		1Ch						Default (07h)
7	6	5	4	3	2	1	0	
Reserved				Red Coarse Gain [3:0]				

Red Coarse Gain [3:0]: 4-bit coarse analog gain for Red channel (applied before ADC).

## Fine Offset LSBs

Subaddress		1Dh						Default (00h)
7	6	5	4	3	2	1	0	
Reserved		Red Fine Offset [1:0]		Green Fine Offset [1:0]		Blue Fine Offset [1:0]		

Red Fine Offset [1:0]: Two LSBs of 10-bit fine digital offset for Red channel (applied after ADC). Corresponding eight MSBs located at register 0Dh. Offset binary value.

Green Fine Offset [1:0]: Two LSBs of 10-bit fine digital offset for Green channel (applied after ADC). Corresponding eight MSBs located at register 0Ch. Offset binary value.

Blue Fine Offset [1:0]: Two LSBs of 10-bit fine digital offset for Blue channel (applied after ADC). Corresponding eight MSBs located at register 0Bh. Offset binary value.

### Blue Coarse Offset

Subaddress		1Eh						Default (10h)
7	6	5	4	3	2	1	0	
Reserved		Blue Coarse Offset [5:0]						

Blue Coarse Offset [5:0]: 6-bit coarse analog offset for Blue channel (applied before ADC). 6-bit sign magnitude value. Coarse Offset settings less than 10h can lead to bottom level clipping at the ADC input.

- 1Fh = +124 counts
- 10h = +64 counts referred to ADC output (default)
- 01h = +4 counts
- 00h = +0 counts
- 20h = –0 counts
- 21h = –4 counts
- 3Fh = –124 LSB

### Green Coarse Offset

Subaddress		1Fh						Default (10h)
7	6	5	4	3	2	1	0	
Reserved		Green Coarse Offset [5:0]						

Green Coarse Offset [5:0]: 6-bit coarse analog offset for Green channel (applied before ADC). 6-bit sign magnitude value.

### Red Coarse Offset

Subaddress		20h						Default (10h)
7	6	5	4	3	2	1	0	
Reserved		Red Coarse Offset [5:0]						

Red Coarse Offset [5:0]: 6-bit coarse analog offset for Red channel (applied before ADC). 6-bit sign magnitude value.

### HSOUT Output Start

Subaddress		21h						Default (0Dh)
7	6	5	4	3	2	1	0	
HSOUT Start [7:0]								

HSOUT Start [7:0]: Adjusts the leading edge of the HSYNC output relative to the leading edge of the HSYNC input in pixel or clock cycles.

### MISC Control 4

Subaddress	22h						Default (08h)
7	6	5	4	3	2	1	0
SP Reset	Yadj_delay [2:0]			MAC_EN	Coast Dis	VS Select	VS Bypass

SP Reset: Active-high reset for Sync Processing block. This bit may be used to manually reset the sync separator, sync accumulator, activity and polarity detectors, and line and pixels counters.

- 0 = Normal operation (default)
- 1 = Sync processing reset

Yadj\_delay [2:0]: Adjusts the phase delay of the luma output relative to the chroma output. Used to compensate for the chroma delay associated with the 4:4:4 to 4:2:2 chroma sample conversion.

- 0h = Minimum delay (default)
- 7h = Maximum delay

MAC\_EN: Toggling of the MAC\_EN bit was required for TVP7000 and TVP7001 Macrovision support. This is no longer required with the TVP7002.

- 0 = Macrovision stripper disabled (recommended setting for nominal HD and PC graphics inputs).
- 1 = Macrovision stripper enabled (default)

NOTE: When the Macrovision stripper is enabled, ALC and Clamp pulse placement is affected by the Macrovision Stripper Width setting. See Register 34h for details.

Coast Dis: Active-high internal coast signal disable for 5-wire PC graphics inputs. Has no effect when the external coast signal is selected. See bit 5 of register 0Fh.

- 0 = Internal coast signal enabled (default)
- 1 = Internal coast signal disabled

VS Select: VSYNC select

- 0 = VSOUT is generated by the sync separator (default). When there is no sync separator activity, VSOUT will be generated by the half line accumulator .
- 1 = VSOUT is generated by the half line accumulator

VS Bypass: VSYNC timing bypass

- 0 = Normal operation (default). VS is derived from the sync separator or half line accumulator based on VS select, and the internal pixel/line counters. Register 35h can be used to adjust VSOUT alignment relative to HSOUT.
- 1 = Bypass VSYNC processing. VSOUT is derived directly from the sync separator. VSOUT delay varies with sync separator threshold (register 11h). Register 35h has no effect.

### Blue Digital ALC Output LSBs

Subaddress	23h							Read only
7	6	5	4	3	2	1	0	
Blue ALC Out [7:0]								

Blue ALC Out [7:0]: Eight LSBs of 10-bit filtered digital ALC output for Blue channel. The corresponding two MSBs are located at subaddress 27h. With the internal ALC loop enabled, the ADC dynamic range can be maximized by adjusting the coarse offset settings based on the ALC read back values. See registers 1Eh–20h for analog coarse offset control. If large adjustments are made to the analog coarse offset control, adequate time must be allowed for the ALC to converge prior to reading of this register. ALC delay requirements will depend on the ALC NSV filter settings and the video input line rate. A delay of 30ms should be adequate for a 480i input with an NSV setting of 1/64. ALC NSV filtering can be increased following final coarse offset adjustment. See register 28h for more information on ALC filter settings. Twos-complement value.

ALC Out[9:0] = ADC output – 512

For bottom-level clamped inputs (YRGB):

- Target ADC output blank level = 32 to avoid bottom level clipping at ADC  
ALC Out[9:0] = 32 – 512 = –480 = 220h
- Starting from positive offset, decrement YRGB coarse offset until ALC Out [9:0] ≤ 220h

For mid-level clamped inputs (PbPr):

- Target ADC output blank level = 512  
ALC Out[9:0] = 512 – 512 = 0
- Starting from positive offset, decrement PbPr coarse offset until ALC Out [9:0] ≤ 0.

### Green Digital ALC Output LSBs

Subaddress	24h							Read only
7	6	5	4	3	2	1	0	
Green ALC Out [7:0]								

Green ALC Out [7:0]: Eight LSBs of 10-bit filtered digital ALC output for Green channel. The corresponding two MSBs are located at subaddress 27h. Twos-complement value. Also see register 23h.

### Red Digital ALC Output LSBs

Subaddress	25h							Read only
7	6	5	4	3	2	1	0	
Red ALC Out [7:0]								

Red ALC Out [7:0]: Eight LSBs of 10-bit filtered digital ALC output for Red channel. The corresponding two MSBs are located at subaddress 27h. Twos-complement value. Also see register 23h.

### Automatic Level Control Enable

Subaddress	26h							Default (80h)
7	6	5	4	3	2	1	0	
ALC enable	Reserved							

ALC enable: Active-high automatic level control (ALC) enable

0 = ALC disabled

1 = ALC enabled (default)

See the ALC Placement register located at subaddress 31h.

### Digital ALC Output MSBs

Subaddress	27h							Read only
7	6	5	4	3	2	1	0	
Reserved		Red ALC Out [9:8]		Green ALC Out [9:8]		Blue ALC Out [9:8]		

Red ALC Out [9:8]: Two MSBs of 10-bit filtered digital ALC output for Red channel. The corresponding eight LSBs are located at subaddress 25h. Twos-complement value.

Green ALC Out [9:8]: Two MSBs of 10-bit filtered digital ALC output for Green channel. The corresponding eight LSBs are located at subaddress 24h. Twos-complement value.

Blue ALC Out [9:8]: Two MSBs of 10-bit filtered digital ALC output for Blue channel. The corresponding eight LSBs are located at subaddress 23h. Twos-complement value.

### Automatic Level Control Filter

Subaddress	28h							Default (53h)
7	6	5	4	3	2	1	0	
Reserved	NSV [3:0]				NSH [2:0]			

NSV [3:0]: ALC vertical filter coefficient. First-order recursive filter coefficient. ALC updates once per video line.

NSV [3:0]	Description
0000 = 1	Fastest setting. ALC converges in one iteration (i.e., one video line)
0001 = 1/2	
0010 = 1/4	
0011 = 1/8	
0100 = 1/16	
0101 = 1/32	
0110 = 1/64	
0111 = 1/128	
1000 = 1/256	
1001 = 1/512	
1010 = 1/1024 (default)	Slowest setting. Provides the most filtering.
1011 = 1/1024	
1100 = 1/1024	
1101 = 1/1024	
1110 = 1/1024	
1111 = 1/1024	

NSH [2:0]: ALC horizontal sample filter coefficient. Multi-tap running average filter coefficient.

NSH [2:0]	Description
000 = 1/2	2-tap running average filter
001 = 1/4	
010 = 1/8	
011 = 1/16 (default)	
100 = 1/32	
101 = 1/64	
110 = 1/128	
111 = 1/256	256-tap running average filter

### Reserved

Subaddress	29h							Default (08h)
7	6	5	4	3	2	1	0	
Reserved [7:0]								

Reserved [7:0]:

08h = Required (default)

## Fine Clamp Control

Subaddress	2Ah						Default (07h)
7	6	5	4	3	2	1	0
CM Offset	Reserved		Fine swsel [1:0]		Reserved	Fine GB	Fine R

CM Offset: Fine bottom-level clamp common mode offset enable. The common mode offset is approximately 300 mV when enabled. Has no effect when the coarse clamp or fine mid-level clamp is selected. See registers 10h and 2Dh.

0 = Common mode offset disabled (default)

1 = Common mode offset enabled

NOTE: The 300-mV common-mode offset can be enabled to improve isolation and channel crosstalk, when inputs with sync tips larger than nominal (>300 mV) must be supported.

Reserved [6:5]:

0 = Normal operation (default)

Fine swsel [1:0]: Fine clamp time constant adjustment

00 = Longest time constant (default)

11 = Shortest time constant

Reserved [2]:

1 = Normal operation (default)

Fine GB: Active-high fine clamp enable for Green and Blue channel

0 = Green channel fine clamp disabled

1 = Green and Blue channel fine clamps enabled (default)

Fine R: Active-high fine clamp enable for Red channel

0 = Red channel fine clamp disabled

1 = Red channel fine clamp enabled (default)

NOTE: Leave Fine GB and Fine R bits turned on for proper clamp operation. See register 10h for mid and bottom level clamping control.

## Power Control

Subaddress	2Bh						(Default 00h)
7	6	5	4	3	2	1	0
Reserved	SOG	SLICER	REF	CURRENT	PW ADC B	PW ADC G	PW ADC R

SOG:

0 = Normal operation (default)

1 = SOG power-down

Slicer:

0 = Normal operation (default)

1 = Slicer power-down

Reference:

0 = Normal operation (default)

1 = Reference block power-down

Current control:

0 = Normal operation (default)

1 = Current control block power-down

PW ADC B: Active-high power-down for ADC Blue channel

0 = ADC Blue channel power-down disabled (default)

1 = ADC Blue channel power-down enabled

PW ADC G: Active-high power-down for ADC Green channel

0 = ADC Green channel power-down disabled (default)

1 = ADC Green channel power-down enabled

PW ADC R: Active-high power-down for ADC Red channel

0 = ADC Red channel power-down disabled (default)

1 = ADC Red channel power-down enabled

## ADC Setup

Subaddress	2Ch							(Default 50h)
7	6	5	4	3	2	1	0	
ADC bias control [3:0]				Trim clamp [3:0]				

ADC bias control [3:0]: Allows adjusting the internal ADC bias current for optimum performance.

- 0h = Minimum setting
- 5h = Recommended setting for sample rates  $\leq$  110 MSPS (default)
- 8h = Recommended setting for sample rates  $>$  110 MSPS
- Fh = Maximum setting

Trim clamp [3:0]: SOG coarse clamp bias current control.

- 0h = 2  $\mu$ A (default)
- 3h = 8  $\mu$ A
- Fh = 32  $\mu$ A

IBIAS = 2 + 2  $\times$  NBIAS, where  $0 \leq$  NBIAS  $\leq$  15

The SOG coarse clamp leakage current (subaddress 30h) is derived from the SOG coarse clamp bias current.

## Coarse Clamp Control

Subaddress	2Dh							Default (00h)
7	6	5	4	3	2	1	0	
CCCLP_cur_CH1 [1:0]		Reserved [5:3]			Coarse B	Coarse G	Coarse R	

CCCLP\_cur\_CH1 [1:0]: Coarse clamp charge current switch selection.

- 00 = Highest charge current setting (default)
- 11 = Lowest charge current setting

Reserved [5:3]:

- 000 = Normal operation (default)

Coarse B: Active-high coarse clamp enable for Blue channel

- 0 = Blue channel coarse clamp disabled (default)
- 1 = Blue channel coarse clamp enabled

Coarse G: Active-high coarse clamp enable for Green channel

- 0 = Green channel coarse clamp disabled (default)
- 1 = Green channel coarse clamp enabled

Coarse R: Active-high coarse clamp enable for Red channel

- 0 = Red channel coarse clamp disabled (default)
- 1 = Red channel coarse clamp enabled

NOTE: Enabling Coarse clamps will disable Fine clamps and override Fine clamp enable settings in subaddress 2Ah.

## SOG Clamp

Subaddress	2Eh							(Default 80h)
7	6	5	4	3	2	1	0	
SOG_CE	CCCLP_cur_SOG [1:0]		upi_sog	dwni_sog	upi_ch123 [2:0]			

SOG\_CE: Active-high SOG clamp enable.

- 0 = SOG clamp disabled
- 1 = SOG clamp enabled (default)

CCCLP\_cur\_SOG [1:0]: SOG coarse clamp charge current switch selection.

- 00 = Lowest charge current setting (default)
- 11 = Highest charge current setting

Reserved [4:0]:

- 0 = Normal operation (default)

## RGB Coarse Clamp Control

Subaddress		2Fh						(Default 8Ch)
7	6	5	4	3	2	1	0	
Reserved		RGB leakage [5:0]						

RGB leakage [5:0]: RGB channel coarse clamp leakage current switch. Increasing the coarse clamp leakage current increases horizontal droop but improves hum rejection.

00h = 0.5  $\mu$ A

0Ch = 6.5  $\mu$ A when IBIAS = 2  $\mu$ A (default)

3Fh = 32.0  $\mu$ A when IBIAS = 2  $\mu$ A

Droop\_Current =  $0.5 + (\text{IBIAS}/4) \times N_{\text{DC}}$ , where  $0 \leq N_{\text{DC}} \leq 63$

## SOG Coarse Clamp Control

Subaddress		30h						(Default 04h)
7	6	5	4	3	2	1	0	
Reserved		SOG leakage [5:0]						

SOG leakage [5:0]: SOG coarse clamp leakage current switch. The SOG coarse clamp leakage current is derived from the bias current. Increasing the coarse clamp leakage current increases horizontal droop but improves hum rejection.

00h = 0.01  $\mu$ A

04h = 0.21  $\mu$ A when IBIAS = 2  $\mu$ A (default)

3Fh = 3.16  $\mu$ A when IBIAS = 2  $\mu$ A

Droop\_Current =  $(0.01 + (\text{IBIAS}/40)) \times N_{\text{DC}}$ , where  $0 \leq N_{\text{DC}} \leq 63$

NOTE: IBIAS is controlled using Trim clamp [3:0] at subaddress 2Ch.

## ALC Placement

Subaddress		31h						(Default 5Ah)
7	6	5	4	3	2	1	0	
ALC placement [7:0]								

ALC placement [7:0]: Positions the ALC signal an integer number of clock periods after either the leading edge or the trailing edge (default) of the HSYNC signal. Bit 3 of subaddress 15h allows selecting which edge of HSYNC is used as the timing reference for ALC placement. The ALC must be applied after the end of the fine clamp interval.

0 = Minimum setting

18h = PC graphics and SDTV with bi-level syncs

5Ah = HDTV with tri-level syncs (default)

## Reserved

Subaddress		32h						Default (18h)
7	6	5	4	3	2	1	0	
Reserved [7:0]								

## Reserved

Subaddress		33h						Default (60h)
7	6	5	4	3	2	1	0	
Reserved								

## Macrovision Stripper Width

Subaddress	34h							Default (03h)
7	6	5	4	3	2	1	0	
stripper width [7:0]								

When the MAC\_EN bit in Reg 22h is set to 1, this setting creates a stripper window around HSYNC for masking Macrovision pseudo-syncs or glitches that could affect PLL lock. The actual stripper width is determined from the stripper width [7:0] setting and can be approximated by  $2 \times \text{stripper width [7:0]} \times \text{REFCLK period}$ . If set too low, stripper width [7:0] can adversely affect fine clamp and ALC placement. Reg 3Bh can be used for read-back of the HSYNC width for automation of this setup. To ensure proper operation of fine clamp and ALC, a minimum stripper width [7:0] setting of Reg 3Bh (HSYNC width) + Reg 3Dh (Line Length Tolerance) can be used. The maximum width is determined from the start of the Macrovision pseudo-syncs and the video input line length. Stripper width [7:0] settings exceeding one half of the input video line length cannot be used. Recommended settings for the more common formats are shown below for a Line Length Tolerance setting of 3. Stripper width [7:0] has no effect, when the MAC\_EN bit in Reg 22h is set to 0.

**Table 15. Recommended Stripper Width Settings**

VIDEO STANDARD	INTERNAL REFCLK USED	EXTERNAL 27-MHZ REFCLK USED
480i and 576i	24h	83h
480p and 576p	12h	43h
720p	07h	12h
1080i	07h	13h
1080p	03h	09h

## VSYNC Alignment

Subaddress	35h							Default (10h)
7	6	5	4	3	2	1	0	
VS-HS Align [7:0]								

VS-HS Align [7:0]: Specifies the number of pixels that the leading edge of the VSYNC output should be delayed or advanced relative to the leading edge of the HSYNC output. The Field ID output is delayed by the same amount. Twos-complement number. This register has no effect when either Sync bypass mode is enabled (see subaddresses 22h and 36h).

00h–7Fh = VSYNC leading edge delayed relative to the HSYNC leading edge

FFh–80h = VSYNC leading edge advanced relative to the HSYNC leading edge

## Sync Bypass

Subaddress	36h							Default (00h)
7	6	5	4	3	2	1	0	
Reserved				VS INV	HS INV	VS BP	HS BP	

VS INV: VSYNC output polarity control. This bit only has an effect if the VSYNC bypass is asserted (bit 1 = 1).

0 = HSYNC output polarity matches input polarity (default)

1 = HSYNC output polarity inverted

HS INV: HSYNC output polarity control. This bit only has an effect if the HSYNC bypass is asserted (bit 0 = 1).

0 = HSYNC output polarity matches input polarity (default)

1 = HSYNC output polarity inverted

VS BP: VSYNC bypass. This bit enables bypassing the Sync processing block in order to output a raw unprocessed VSYNC.

0 = Normal operation (default)

1 = VSYNC bypass mode. Can be used with PC graphics using discrete syncs.

HS BP: HSYNC bypass. This bit enables bypassing the Sync processing block in order to output a raw unprocessed HSYNC.

0 = Normal operation (default)

1 = HSYNC bypass mode. Can be used for sync detection but is not recommended for normal operation

NOTE: See register 14h for input sync polarity detect.

## Lines Per Frame Status

Subaddress	37h–38h							Read only
Subaddress	7	6	5	4	3	2	1	0
37h	Lines per Frame [7:0]							
38h	Reserved	mac detect	P/I detect	Reserved	Lines per Frame [11:8]			

mac detect: Macrovision pseudo-sync detection status

0 = Macrovision not detected

1 = Macrovision detected

P/I detect: Progressive/interlaced video detection status. Not dependent on the H-PLL being locked.

0 = Interlaced video detected

1 = Progressive video detected

Lines per Frame [11:0]: Number of lines per frame.

The lines per frame value may be used along with the clocks per line value (subaddresses 39h–3Ah) to determine the vertical frequency ( $f_v$ ) of the video input.

$$f_v = \text{clock reference frequency} / \text{clocks per line} / \text{lines per frame}$$

NOTE: The Lines per Frame counter is not dependent on the H-PLL being locked.

**Table 16. Expected Status Read-Back When Using a 27-MHz REFCLK**

Format	Clocks Per Line	Lines per frame	HSYNC Width	I/P Bit	HS POL	HS POL
480i60Hz	1716	525	126	0	1	1
480p60Hz	858	525	63	1	1	1
576i50Hz	1728	625	126	0	1	1
576p50Hz	864	625	63	1	1	1
720p60Hz	600	750	14	1	1	1
1080i60Hz	800	1125	16	0	1	1
1080p60Hz	400	1125	8	1	1	1
XGA60Hz	558	806	56	1	0	0
XGA75Hz	449	800	32	1	1	1

## Clocks Per Line Status

Subaddress	39h–3Ah							Read only
Subaddress	7	6	5	4	3	2	1	0
39h	Clocks per Line [7:0]							
3Ah	Reserved				Clocks per Line [11:8]			

Clocks per Line [11:0]: Number of clock cycles per line. The value written to this register represents the length of the longest line per frame. A known timing reference based on either the internal clock reference (~6.5 MHz) or an external clock reference input (EXT\_CLK) of up to 27 MHz may be selected using subaddress 1Ah.

The clocks per line value may be used to determine the horizontal frequency ( $f_H$ ) of the video input.

$$f_H = \text{clock reference frequency} / \text{clocks per line}$$

NOTE: The Clocks per Line counter is not dependent on the H-PLL being locked.

## HSYNC Width

Subaddress	3Bh							Read only
7	6	5	4	3	2	1	0	
HSYNC width [7:0]								

HSYNC width [7:0]: Number of clock cycles between the leading and trailing edges of the HSYNC input. A known timing reference based on either the internal clock reference (~6.5 MHz) or an external clock reference input (EXT\_CLK) of up to 27 MHz may be selected using subaddress 1Ah.

NOTE: The HSYNC width counter is not dependent on the H-PLL being locked.

**VSYNC Width**

Subaddress	3Ch							Read only
7	6	5	4	3	2	1	0	
Reserved			VSYNC width [4:0]					

VSYNC width [4:0]: Number of lines between the leading and trailing edges of the VSYNC input. The VSYNC width along with the HSYNC and VSYNC polarities can be used to determine whether the input graphics format is using VESA-CVT generated timings.

NOTE: The VSYNC width counter is not dependent on the H-PLL being locked.

**Line Length Tolerance**

Subaddress	3Dh							Default (03h)
7	6	5	4	3	2	1	0	
Reserved	Line length tolerance [6:0]							

Line length tolerance [6:0]: Controls sensitivity to HSYNC input stability when using either the internal or external clock reference. Increased line length tolerance settings may be required for input signals having horizontal instability. This setting may affect the precision of the clock cycles per line counter (see subaddresses 39h–3Ah)

- 00h = (minimum) tolerance
- 03h = (default) tolerance
- 06h = (recommended) tolerance
- 7Fh = (maximum) tolerance

**Reserved**

Subaddress	3Eh							Default (04h)
7	6	5	4	3	2	1	0	
Reserved [7:0]								

Reserved [7:0]:

- 04h = Required setting (default)

**Video Bandwidth Control**

Subaddress	3Fh							Default (00h)
7	6	5	4	3	2	1	0	
Reserved			BW select [3:0]					

BW select [3:0]: Selectable low-pass filter settings for controlling the analog video bandwidth. This control affects the analog video bandwidth of all three ADC channels.

- 0h = Highest video bandwidth (default)
- Fh = Lowest video bandwidth (~95 MHz analog video bandwidth )

NOTE: This register can be used to filter high frequency noise but lacks the precision for maximum filtering of various video formats. The lowest bandwidth setting provides a video bandwidth of at least 50 MHz.

**AVID Start Pixel**

Subaddress	40h–41h							Default (012Ch)
Subaddress	7	6	5	4	3	2	1	0
40h	AVID start [7:0]							
41h	Reserved		AVID active	AVID start [12:8]				

AVID active

- 0 = AVID out active during VBLK (default)
- 1 = AVID out inactive during VBLK

AVID start [12:0]: AVID start pixel number, this is an absolute pixel location from the leading edge of HSYNC (start pixel 0). The TVP7002 updates the AVID start only when the AVID start MSB byte is written to.

AVID start pixel register also controls the position of SAV code. The TVP7002 inserts the SAV code four pixels before the pixel number specified in the AVID start pixel register.

### AVID Stop Pixel

Subaddress	42h–43h							Default (062Ch)
Subaddress	7	6	5	4	3	2	1	0
42h	AVID stop [7:0]							
43h	Reserved			AVID stop [12:8]				

AVID stop [12:0]: AVID stop pixel number. The number of pixels of active video must be an even number. This is an absolute pixel location from the leading edge of HSYNC (start pixel 0).

The TVP7002 updates the AVID Stop only when the AVID Stop MSB byte is written to.

AVID stop pixel register also controls the position of EAV code.

### VBLK Field 0 Start Line Offset

Subaddress	44h							Default (05h)
	7	6	5	4	3	2	1	0
VBLK start 0 [7:0]								

VBLK start 0 [7:0]: VBLK start line offset for field 0 relative to the leading edge of VSYNC. The VBLK start line offset value affects the location of transitions on the embedded sync V-bit and VBLK of the Data Enable output, but not the VSYNC output (VSOUT). Unsigned integer.

### VBLK Field 1 Start Line Offset

Subaddress	45h							Default (05h)
	7	6	5	4	3	2	1	0
VBLK start 1 [7:0]								

VBLK start 1 [7:0]: VBLK start line offset for field 1 relative to the leading edge of VSYNC. The VBLK start line offset value affects the location of transitions on the embedded sync V-bit and VBLK of the Data Enable output, but not the VSYNC output (VSOUT). Unsigned integer.

### VBLK Field 0 Duration

Subaddress	46h							Default (1Eh)
	7	6	5	4	3	2	1	0
VBLK duration 0 [7:0]								

VBLK duration 0 [7:0]: VBLK duration in lines for field 0.

### VBLK Field 1 Duration

Subaddress	47h							Default (1Eh)
	7	6	5	4	3	2	1	0
VBLK duration 1 [7:0]								

VBLK duration 1 [7:0]: VBLK duration in lines for field 1.

### F-bit Field 0 Start Line Offset

Subaddress	48h							Default (00h)
	7	6	5	4	3	2	1	0
F-bit start 0 [7:0]								

F-bit start 0 [7:0]: F-bit Field 0 start line offset relative to the leading edge of VSYNC, signed integer, set F-bit to 0 until field 1 start line, it only applies in interlaced mode. For a non-interlace mode, F-bit is always set to 0.

NOTE: The field ID output (FIDOUT) is always aligned with the leading edge of the VSYNC output (VSOUT).

### F-bit Field 1 Start Line Offset

Subaddress		49h						Default (00h)	
		7	6	5	4	3	2	1	0
F-bit start 1 [7:0]									

F-bit start 1 [7:0]: F-bit Field 1 start line offset relative to the leading edge of VSYNC, signed integer, set F-bit to 1 until field 0 start line, it only applies in interlaced mode. For a non-interlace mode, F-Bit is always set to 0.

NOTE: The field ID output (FIDOUT) is always aligned with the leading edge of the VSYNC output (VSOUT).

### 1st CSC Coefficient

Subaddress		4Ah–4Bh						Default (16E3h)	
Subaddress		7	6	5	4	3	2	1	0
4Ah		1st Coefficient [7:0]							
4Bh		1st Coefficient [15:8]							

1st Coefficient [15:0]: 16-bit G' coefficient MSB for Y

### 2nd CSC Coefficient

Subaddress		4Ch–4Dh						Default (024Fh)	
Subaddress		7	6	5	4	3	2	1	0
4Ch		2nd Coefficient [7:0]							
4Dh		2nd Coefficient [15:8]							

2nd Coefficient [15:0]: 16-bit B' coefficient MSB for Y

### 3rd CSC Coefficient

Subaddress		4Eh–4Fh						Default (06CEh)	
Subaddress		7	6	5	4	3	2	1	0
4Eh		3rd Coefficient [7:0]							
4Fh		3rd Coefficient [15:8]							

3rd Coefficient [15:0]: 16-bit R' coefficient MSB for Y

### 4th CSC Coefficient

Subaddress		50h–51h						Default (F3ABh)	
Subaddress		7	6	5	4	3	2	1	0
50h		4th Coefficient [7:0]							
51h		4th Coefficient [15:8]							

4th Coefficient [15:0]: 16-bit G' coefficient MSB for U

### 5th CSC Coefficient

Subaddress		52h–53h						Default (1000h)	
Subaddress		7	6	5	4	3	2	1	0
52h		5th Coefficient [7:0]							
53h		5th Coefficient [15:8]							

5th Coefficient [15:0]: 16-bit B' coefficient MSB for U

### 6th CSC Coefficient

Subaddress	54h–55h							Default (FC55h)	
Subaddress	7	6	5	4	3	2	1	0	
54h	6th Coefficient [7:0]								
55h	6th Coefficient [15:8]								

6th Coefficient [15:0]: 16-bit R' coefficient MSB for U

### 7th CSC Coefficient

Subaddress	56h–57h							Default (F178h)	
Subaddress	7	6	5	4	3	2	1	0	
56h	7th Coefficient [7:0]								
57h	7th Coefficient [15:8]								

7th Coefficient [15:0]: 16-bit G' coefficient MSB for V

### 8th CSC Coefficient

Subaddress	58h–59h							Default (FE88h)	
Subaddress	7	6	5	4	3	2	1	0	
58h	8th Coefficient [7:0]								
59h	8th Coefficient [15:8]								

8th Coefficient [15:0]: 16-bit B' coefficient MSB for V

### 9th CSC Coefficient

Subaddress	5Ah–5Bh							Default (1000h)	
Subaddress	7	6	5	4	3	2	1	0	
5Ah	9th Coefficient [7:0]								
5Bh	9th Coefficient [15:8]								

9th Coefficient [15:0]: 16-bit R' coefficient MSB for V

APPLICATION INFORMATION

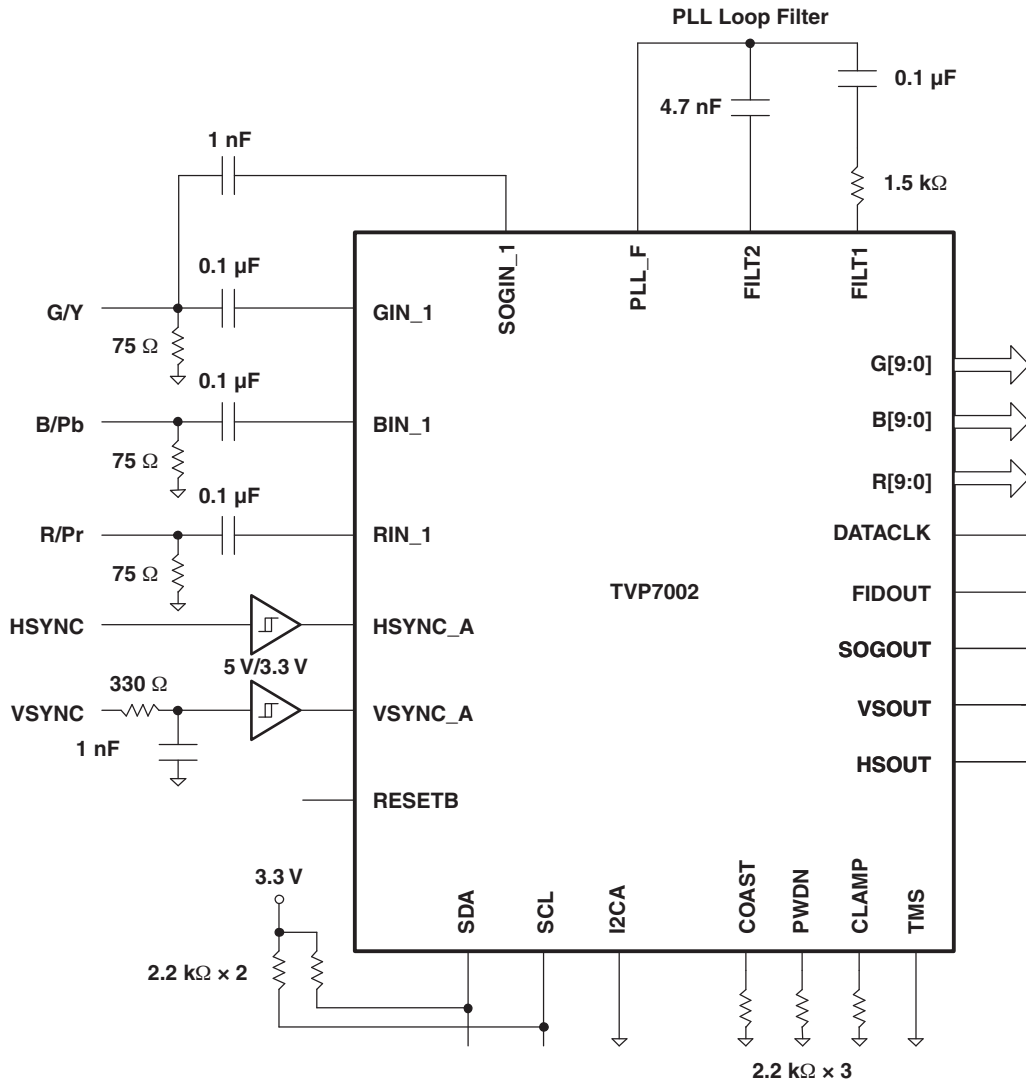

NOTE: System level ESD protection is not shown in this application circuit but is highly recommended on the RGB and H/VSYNC inputs.

Figure 8. TVP7002 Application Example

## REVISION HISTORY

Revision	Comments
SLES206	Initial Release
SLES206A	Changed Functional Block Diagram Updated Timing Requirements Changed Sync Activity Detection section Changed Power Up, Reset, and Initialization section Editorial changes throughout
SLES206B	Modified pin 73 I2CA pin description in <a href="#">Table 1</a> , Terminal Functions. <a href="#">Reset and I2C Bus Address Selection</a> section, Modified I2CA description and <a href="#">Table 10</a> . Modified Supported Formats and Sync Separator sections. Added format detection information to the <a href="#">Control Registers</a> section Added sync separator information to the <a href="#">Control Registers</a> section Modified H-PLL Phase Select register bit description. Modified Input Mux Select 2 register bit description. Modified Blue Coarse Offset register bit description. Modified the Output Timing Information in <a href="#">Figure 6</a> . Added information to the <a href="#">Embedded Syncs</a> section.
SLES206C	<a href="#">Table 4</a> , Standard: Video, Resolution: 720 x 480i: Changed Line Rate (kHz) from 15.374 to 15.734. <a href="#">Table 4</a> , Standard: Video, Resolution: 1920 x 1080i: Changed Frame Rate (Hz) from 60 to 30 and from 50 to 25.

**PACKAGING INFORMATION**

Orderable Device	Status (1)	Package Type	Package Drawing	Pins	Package Qty	Eco Plan (2)	Lead/Ball Finish (6)	MSL Peak Temp (3)	Op Temp (°C)	Device Marking (4/5)	Samples
TVP7002PZP	NRND	HTQFP	PZP	100	90	Green (RoHS & no Sb/Br)	CU NIPDAU	Level-3-260C-168 HR	0 to 70	TVP7002	
TVP7002PZPR	NRND	HTQFP	PZP	100	1000	Green (RoHS & no Sb/Br)	CU NIPDAU	Level-3-260C-168 HR	0 to 70	TVP7002	

(1) The marketing status values are defined as follows:

**ACTIVE:** Product device recommended for new designs.

**LIFEBUY:** TI has announced that the device will be discontinued, and a lifetime-buy period is in effect.

**NRND:** Not recommended for new designs. Device is in production to support existing customers, but TI does not recommend using this part in a new design.

**PREVIEW:** Device has been announced but is not in production. Samples may or may not be available.

**OBSOLETE:** TI has discontinued the production of the device.

(2) Eco Plan - The planned eco-friendly classification: Pb-Free (RoHS), Pb-Free (RoHS Exempt), or Green (RoHS & no Sb/Br) - please check <http://www.ti.com/productcontent> for the latest availability information and additional product content details.

**TBD:** The Pb-Free/Green conversion plan has not been defined.

**Pb-Free (RoHS):** TI's terms "Lead-Free" or "Pb-Free" mean semiconductor products that are compatible with the current RoHS requirements for all 6 substances, including the requirement that lead not exceed 0.1% by weight in homogeneous materials. Where designed to be soldered at high temperatures, TI Pb-Free products are suitable for use in specified lead-free processes.

**Pb-Free (RoHS Exempt):** This component has a RoHS exemption for either 1) lead-based flip-chip solder bumps used between the die and package, or 2) lead-based die adhesive used between the die and leadframe. The component is otherwise considered Pb-Free (RoHS compatible) as defined above.

**Green (RoHS & no Sb/Br):** TI defines "Green" to mean Pb-Free (RoHS compatible), and free of Bromine (Br) and Antimony (Sb) based flame retardants (Br or Sb do not exceed 0.1% by weight in homogeneous material)

(3) MSL, Peak Temp. - The Moisture Sensitivity Level rating according to the JEDEC industry standard classifications, and peak solder temperature.

(4) There may be additional marking, which relates to the logo, the lot trace code information, or the environmental category on the device.

(5) Multiple Device Markings will be inside parentheses. Only one Device Marking contained in parentheses and separated by a "~" will appear on a device. If a line is indented then it is a continuation of the previous line and the two combined represent the entire Device Marking for that device.

(6) Lead/Ball Finish - Orderable Devices may have multiple material finish options. Finish options are separated by a vertical ruled line. Lead/Ball Finish values may wrap to two lines if the finish value exceeds the maximum column width.

**Important Information and Disclaimer:** The information provided on this page represents TI's knowledge and belief as of the date that it is provided. TI bases its knowledge and belief on information provided by third parties, and makes no representation or warranty as to the accuracy of such information. Efforts are underway to better integrate information from third parties. TI has taken and continues to take reasonable steps to provide representative and accurate information but may not have conducted destructive testing or chemical analysis on incoming materials and chemicals. TI and TI suppliers consider certain information to be proprietary, and thus CAS numbers and other limited information may not be available for release.

In no event shall TI's liability arising out of such information exceed the total purchase price of the TI part(s) at issue in this document sold by TI to Customer on an annual basis.

# MECHANICAL DATA

PZP (S-PQFP-G100)

PowerPAD™ PLASTIC QUAD FLATPACK

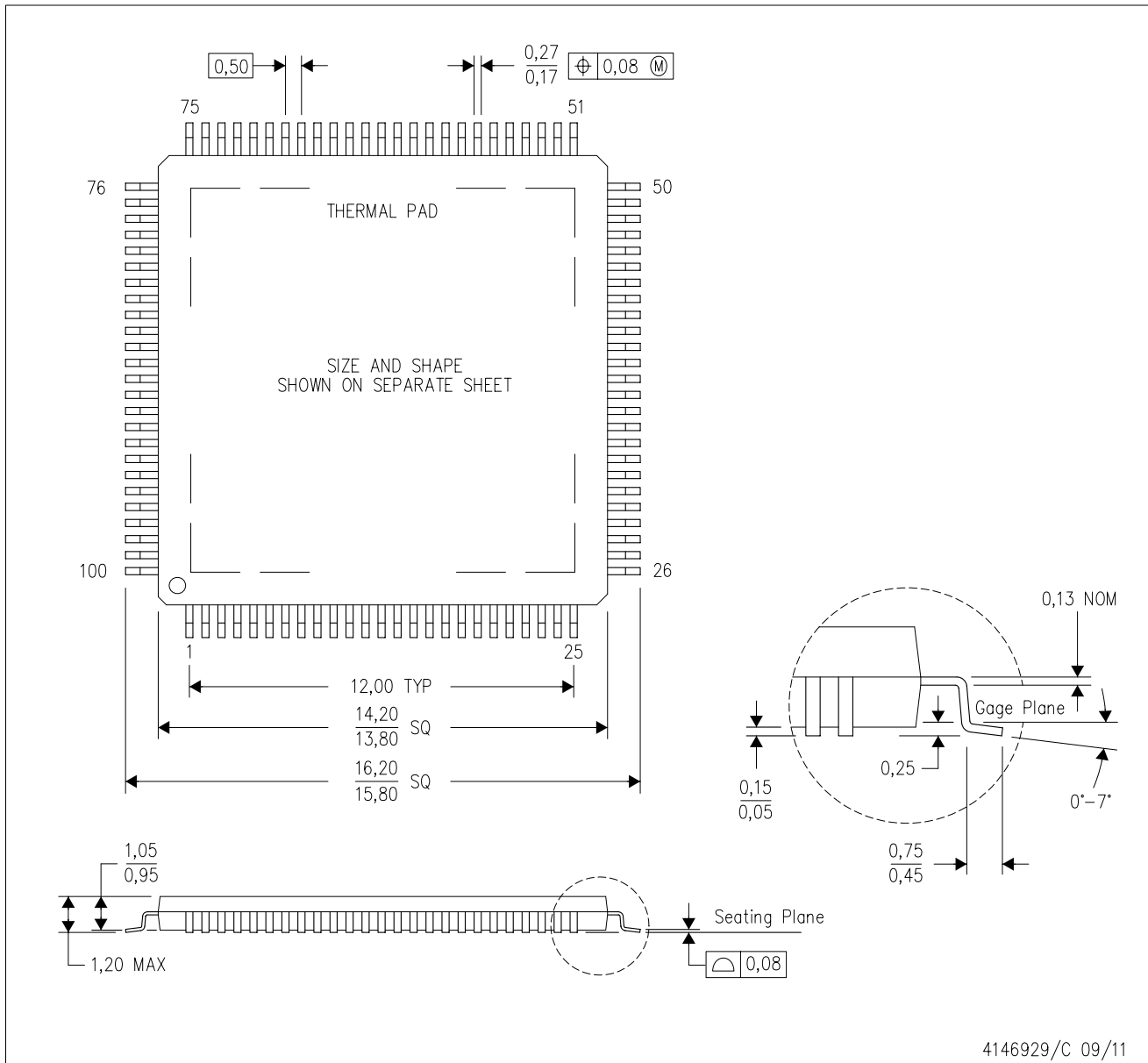

- NOTES:
- A. All linear dimensions are in millimeters.
  - B. This drawing is subject to change without notice.
  - C. Body dimensions do not include mold flash or protrusion
  - D. This package is designed to be soldered to a thermal pad on the board. Refer to Technical Brief, PowerPad Thermally Enhanced Package, Texas Instruments Literature No. SLMA002 for information regarding recommended board layout. This document is available at [www.ti.com](http://www.ti.com) <<http://www.ti.com>>.
  - E. See the additional figure in the Product Data Sheet for details regarding the exposed thermal pad features and dimensions.
  - F. Falls within JEDEC MS-026

PowerPAD is a trademark of Texas Instruments.

# THERMAL PAD MECHANICAL DATA

PZP (S-PQFP-G100)

PowerPAD™ PLASTIC QUAD FLATPACK

## THERMAL INFORMATION

This PowerPAD™ package incorporates an exposed thermal pad that is designed to be attached to a printed circuit board (PCB). The thermal pad must be soldered directly to the PCB. After soldering, the PCB can be used as a heatsink. In addition, through the use of thermal vias, the thermal pad can be attached directly to the appropriate copper plane shown in the electrical schematic for the device, or alternatively, can be attached to a special heatsink structure designed into the PCB. This design optimizes the heat transfer from the integrated circuit (IC).

For additional information on the PowerPAD package and how to take advantage of its heat dissipating abilities, refer to Technical Brief, PowerPAD Thermally Enhanced Package, Texas Instruments Literature No. SLMA002 and Application Brief, PowerPAD Made Easy, Texas Instruments Literature No. SLMA004. Both documents are available at [www.ti.com](http://www.ti.com).

The exposed thermal pad dimensions for this package are shown in the following illustration.

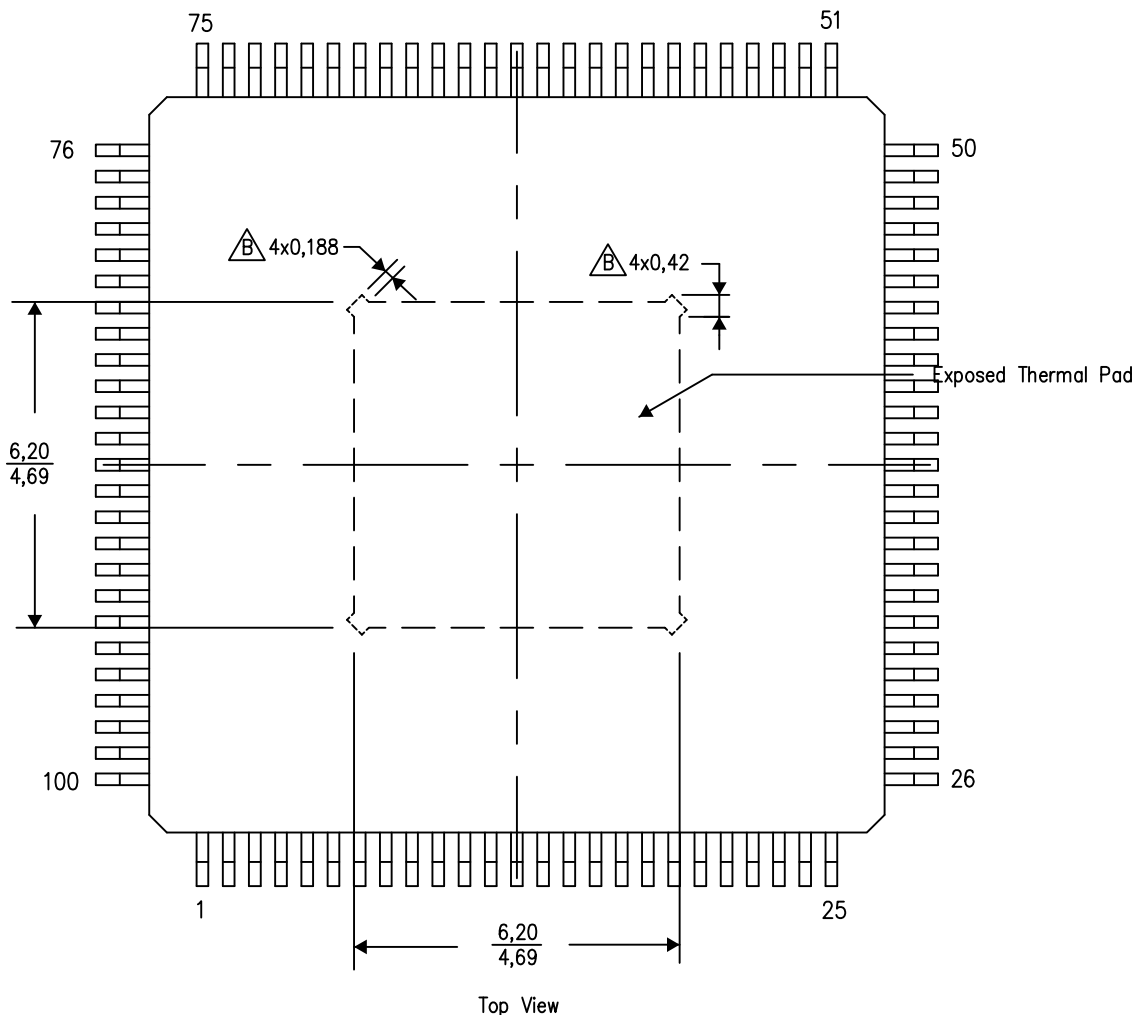

Exposed Thermal Pad Dimensions

4206333-3/L 05/14

NOTE: A. All linear dimensions are in millimeters

 Tie strap features may not be present.

PowerPAD is a trademark of Texas Instruments

## IMPORTANT NOTICE

Texas Instruments Incorporated (TI) reserves the right to make corrections, enhancements, improvements and other changes to its semiconductor products and services per JESD46, latest issue, and to discontinue any product or service per JESD48, latest issue. Buyers should obtain the latest relevant information before placing orders and should verify that such information is current and complete.

TI's published terms of sale for semiconductor products (<http://www.ti.com/sc/docs/stdterms.htm>) apply to the sale of packaged integrated circuit products that TI has qualified and released to market. Additional terms may apply to the use or sale of other types of TI products and services.

Reproduction of significant portions of TI information in TI data sheets is permissible only if reproduction is without alteration and is accompanied by all associated warranties, conditions, limitations, and notices. TI is not responsible or liable for such reproduced documentation. Information of third parties may be subject to additional restrictions. Resale of TI products or services with statements different from or beyond the parameters stated by TI for that product or service voids all express and any implied warranties for the associated TI product or service and is an unfair and deceptive business practice. TI is not responsible or liable for any such statements.

Buyers and others who are developing systems that incorporate TI products (collectively, "Designers") understand and agree that Designers remain responsible for using their independent analysis, evaluation and judgment in designing their applications and that Designers have full and exclusive responsibility to assure the safety of Designers' applications and compliance of their applications (and of all TI products used in or for Designers' applications) with all applicable regulations, laws and other applicable requirements. Designer represents that, with respect to their applications, Designer has all the necessary expertise to create and implement safeguards that (1) anticipate dangerous consequences of failures, (2) monitor failures and their consequences, and (3) lessen the likelihood of failures that might cause harm and take appropriate actions. Designer agrees that prior to using or distributing any applications that include TI products, Designer will thoroughly test such applications and the functionality of such TI products as used in such applications.

TI's provision of technical, application or other design advice, quality characterization, reliability data or other services or information, including, but not limited to, reference designs and materials relating to evaluation modules, (collectively, "TI Resources") are intended to assist designers who are developing applications that incorporate TI products; by downloading, accessing or using TI Resources in any way, Designer (individually or, if Designer is acting on behalf of a company, Designer's company) agrees to use any particular TI Resource solely for this purpose and subject to the terms of this Notice.

TI's provision of TI Resources does not expand or otherwise alter TI's applicable published warranties or warranty disclaimers for TI products, and no additional obligations or liabilities arise from TI providing such TI Resources. TI reserves the right to make corrections, enhancements, improvements and other changes to its TI Resources. TI has not conducted any testing other than that specifically described in the published documentation for a particular TI Resource.

Designer is authorized to use, copy and modify any individual TI Resource only in connection with the development of applications that include the TI product(s) identified in such TI Resource. NO OTHER LICENSE, EXPRESS OR IMPLIED, BY ESTOPPEL OR OTHERWISE TO ANY OTHER TI INTELLECTUAL PROPERTY RIGHT, AND NO LICENSE TO ANY TECHNOLOGY OR INTELLECTUAL PROPERTY RIGHT OF TI OR ANY THIRD PARTY IS GRANTED HEREIN, including but not limited to any patent right, copyright, mask work right, or other intellectual property right relating to any combination, machine, or process in which TI products or services are used. Information regarding or referencing third-party products or services does not constitute a license to use such products or services, or a warranty or endorsement thereof. Use of TI Resources may require a license from a third party under the patents or other intellectual property of the third party, or a license from TI under the patents or other intellectual property of TI.

TI RESOURCES ARE PROVIDED "AS IS" AND WITH ALL FAULTS. TI DISCLAIMS ALL OTHER WARRANTIES OR REPRESENTATIONS, EXPRESS OR IMPLIED, REGARDING RESOURCES OR USE THEREOF, INCLUDING BUT NOT LIMITED TO ACCURACY OR COMPLETENESS, TITLE, ANY EPIDEMIC FAILURE WARRANTY AND ANY IMPLIED WARRANTIES OF MERCHANTABILITY, FITNESS FOR A PARTICULAR PURPOSE, AND NON-INFRINGEMENT OF ANY THIRD PARTY INTELLECTUAL PROPERTY RIGHTS. TI SHALL NOT BE LIABLE FOR AND SHALL NOT DEFEND OR INDEMNIFY DESIGNER AGAINST ANY CLAIM, INCLUDING BUT NOT LIMITED TO ANY INFRINGEMENT CLAIM THAT RELATES TO OR IS BASED ON ANY COMBINATION OF PRODUCTS EVEN IF DESCRIBED IN TI RESOURCES OR OTHERWISE. IN NO EVENT SHALL TI BE LIABLE FOR ANY ACTUAL, DIRECT, SPECIAL, COLLATERAL, INDIRECT, PUNITIVE, INCIDENTAL, CONSEQUENTIAL OR EXEMPLARY DAMAGES IN CONNECTION WITH OR ARISING OUT OF TI RESOURCES OR USE THEREOF, AND REGARDLESS OF WHETHER TI HAS BEEN ADVISED OF THE POSSIBILITY OF SUCH DAMAGES.

Unless TI has explicitly designated an individual product as meeting the requirements of a particular industry standard (e.g., ISO/TS 16949 and ISO 26262), TI is not responsible for any failure to meet such industry standard requirements.

Where TI specifically promotes products as facilitating functional safety or as compliant with industry functional safety standards, such products are intended to help enable customers to design and create their own applications that meet applicable functional safety standards and requirements. Using products in an application does not by itself establish any safety features in the application. Designers must ensure compliance with safety-related requirements and standards applicable to their applications. Designer may not use any TI products in life-critical medical equipment unless authorized officers of the parties have executed a special contract specifically governing such use. Life-critical medical equipment is medical equipment where failure of such equipment would cause serious bodily injury or death (e.g., life support, pacemakers, defibrillators, heart pumps, neurostimulators, and implantables). Such equipment includes, without limitation, all medical devices identified by the U.S. Food and Drug Administration as Class III devices and equivalent classifications outside the U.S.

TI may expressly designate certain products as completing a particular qualification (e.g., Q100, Military Grade, or Enhanced Product). Designers agree that it has the necessary expertise to select the product with the appropriate qualification designation for their applications and that proper product selection is at Designers' own risk. Designers are solely responsible for compliance with all legal and regulatory requirements in connection with such selection.

Designer will fully indemnify TI and its representatives against any damages, costs, losses, and/or liabilities arising out of Designer's non-compliance with the terms and provisions of this Notice.

## Looking for pricing, stock, or lifecycle information?

Click below to explore more details on WIN SOURCE:

 [View TVP7002PZP on WIN SOURCE](#)

 [Texas Instruments](#) Information

## Optimize Your Supply Chain with WIN SOURCE Solutions

-  Global Sourcing Solution
-  Obsolete Management
-  Cost Control Management
-  Shortage Management
-  Alternative Solution
-  Excess Inventory Management