



**THE DATASHEET OF
TVP5147M1PFPR**



TVP5147M1

NTSC/PAL/SECAM 2 11-Bit Digital Video Decoder With Macrovision™ Detection, YPbPr Inputs, and 5-Line Comb Filter

Data Manual



PRODUCTION DATA information is current as of publication date. Products conform to specifications per the terms of the Texas Instruments standard warranty. Production processing does not necessarily include testing of all parameters.

Literature Number: SLES140G
July 2005–Revised February 2012

Contents

1	Introduction	8
1.1	Features	8
1.2	Description	10
1.3	Applications	11
1.4	Related Products	11
1.5	Ordering Information	11
1.6	Functional Block Diagram	12
1.7	Terminal Assignments	13
1.8	Terminal Functions	14
2	Functional Description	16
2.1	Analog Processing and A/D Converters	16
2.1.1	Video Input Switch Control	17
2.1.2	Analog Input Clamping	17
2.1.3	Automatic Gain Control	17
2.1.4	Analog Video Output	17
2.1.5	A/D Converters	18
2.2	Digital Video Processing	18
2.2.1	2x Decimation Filter	18
2.2.2	Composite Processor	18
2.2.2.1	Color Low-Pass Filter	20
2.2.2.2	Y/C Separation	21
2.2.3	Luminance Processing	22
2.2.4	Color Transient Improvement	22
2.3	Clock Circuits	23
2.4	Real-Time Control (RTC)	23
2.5	Output Formatter	24
2.5.1	Separate Syncs	25
2.5.2	Embedded Syncs	30
2.6	I ² C Host Interface	30
2.6.1	Reset and I ² C Bus Address Selection	31
2.6.2	I ² C Operation	31
2.6.3	VBUS Access	32
2.7	VBI Data Processor	33
2.7.1	VBI FIFO and Ancillary Data in Video Stream	34
2.7.2	VBI Raw Data Output	35
2.8	Reset and Initialization	35
2.9	Adjusting External Syncs	36
2.10	Internal Control Registers	37
2.11	Register Definitions	41
2.12	VBUS Register Definitions	86
3	Electrical Specifications	93
3.1	Absolute Maximum Ratings	93
3.2	Recommended Operating Conditions	94
3.3	Crystal Specifications	94
3.4	Electrical Characteristics	95
3.5	DC Electrical Characteristics	95
3.6	Analog Processing and A/D Converters	95
3.7	Clocks, Video Data, Sync Timing	96
3.8	I ² C Host Port Timing	96
3.9	Thermal Specifications	97
4	Example Register Settings	98

4.1	Example 1	98
4.1.1	Assumptions	98
4.1.2	Recommended Settings	98
4.2	Example 2	99
4.2.1	Assumptions	99
4.2.2	Recommended Settings	99
4.3	Example 3	100
4.3.1	Assumptions	100
4.3.2	Recommended Settings	100
5	Application Information	101
5.1	Application Example	101
5.2	Designing With PowerPAD™ Devices	102
	Revision History	103

List of Figures

1-1	Functional Block Diagram	13
1-2	Terminal Assignments Diagram	13
2-1	Analog Processors and A/D Converters	16
2-2	Digital Video Processing Block Diagram	18
2-3	Composite and S-Video Processing Block Diagram.....	19
2-8	Luminance Edge-Enhancer Peaking Block Diagram	22
2-9	Peaking Filter Response, NTSC/PAL ITU-R BT.601 Sampling	22
2-10	Reference Clock Configurations.....	23
2-11	RTC Timing	24
2-12	Vertical Synchronization Signals for 525-Line System	27
2-13	Vertical Synchronization Signals for 625-Line System	28
2-14	Horizontal Synchronization Signals for 10-Bit 4:2:2 Mode.....	29
2-15	Horizontal Synchronization Signals for 20-Bit 4:2:2 Mode.....	30
2-16	VSYNC Position With Respect to HSYNC.....	30
2-17	VBUS Access	33
2-18	Reset Timing	36
2-19	Teletext Filter Function	75
3-1	Clocks, Video Data, and Sync Timing	96
3-2	I ² C Host Port Timing	96
5-1	Example Application Circuit	101

List of Tables

1-1	Terminal Functions	14
2-1	Output Format	24
2-2	Summary of Line Frequencies, Data Rates, and Pixel/Line Counts.....	25
2-3	EAV and SAV Sequence	30
2-4	I ² C Host Interface Terminal Description	31
2-5	I ² C Address Selection	31
2-6	Supported VBI System	33
2-7	Ancillary Data Format and Sequence	34
2-8	VBI Raw Data Output Format	35
2-9	Reset Sequence.....	35
2-10	I ² C Register Summary	37
2-11	VBUS Register Summary	40
2-12	Input Select Register	41
2-13	Analog Channel and Video Mode Selection	41
2-14	AFE Gain Control Register	42
2-15	Video Standard Select Register	42
2-16	Operation Mode Control Register	43
2-17	Autoswitch Mask Register	43
2-18	Color Killer Register	44
2-19	Luminance Processing Control 1 Register	44
2-20	Luminance Processing Control 2 Register	45
2-21	Luminance Processing Control 3 Register	45
2-22	Luminance Brightness Register	45
2-23	Luminance Contrast Register	46
2-24	Chrominance Saturation Register	46
2-25	Chroma Hue Register	46
2-26	Chrominance Processing Control 1 Register	47
2-27	Chrominance Processing Control 2 Register	47
2-28	R/Pr Gain (Color Saturation) Register	47
2-29	G/Y Gain (Contrast) Register	48
2-30	B/Pb Gain (Color Saturation) Register	48
2-31	G/Y Offset Register	48
2-32	AVID Start Pixel Register	49
2-33	AVID Stop Pixel Register	49
2-34	HSYNC Start Pixel Register	49
2-35	HSYNC Stop Pixel Register	50
2-36	VSYNC Start Line Register	50
2-37	VSYNC Stop Line Register	50
2-38	VBLK Start Line Register	50
2-39	VBLK Stop Line Register	51
2-40	Embedded Sync Offset Control 1 Register	51
2-41	Embedded Sync Offset Control 2 Register	51
2-42	CTI Delay Register	52
2-43	CTI Control Register	52
2-44	Brightness and Contrast Range Extender Register	52
2-45	Sync Control Register	53
2-46	Output Formatter Control 1 Register	53

2-47	Output Formatter Control 2 Register	54
2-48	Output Formatter Control 3 Register	54
2-49	Output Formatter Control 4 Register	55
2-50	Output Formatter Control 5 Register	56
2-51	Output Formatter Control 6 Register	57
2-52	Clear Lost Lock Detect Register	57
2-53	Status 1 Register	58
2-54	Status 2 Register	59
2-55	AGC Gain Status Register	59
2-56	Video Standard Status Register	60
2-57	GPIO Input 1 Register	60
2-58	GPIO Input 2 Register	61
2-59	AFE Coarse Gain for CH 1 Register	61
2-60	AFE Coarse Gain for CH 2 Register	62
2-61	AFE Coarse Gain for CH 3 Register	62
2-62	AFE Coarse Gain for CH 4 Register	63
2-63	AFE Fine Gain for Pb Register	63
2-64	AFE Fine Gain for Y_Chroma Register	64
2-65	AFE Fine Gain for Pr Register	64
2-66	AFE Fine Gain for CVBS_Luma Register	64
2-67	Field ID Control Register	65
2-68	F-Bit and V-Bit Decode Control 1 Register	66
2-69	Back-End AGC Control Register	67
2-70	AGC Decrement Speed Register	67
2-71	ROM Version Register	67
2-72	RAM Version MSB Register	67
2-73	AGC White Peak Processing Register	68
2-74	F-Bit and V-Bit Control 2 Register	69
2-75	VCR Trick Mode Control Register	69
2-76	Horizontal Shake Increment Register	70
2-77	AGC Increment Speed Register	70
2-78	AGC Increment Delay Register	70
2-79	Analog Output Control 1 Register	70
2-80	Chip ID MSB Register	71
2-81	Chip ID LSB Register	71
2-82	RAM Version LSB Register	71
2-83	Color PLL Speed Control Register	71
2-84	Status Request Register	71
2-85	Vertical Line Count Register	72
2-86	AGC Decrement Delay Register	72
2-87	VDP TTX Filter and Mask Register	73
2-88	VDP TTX Filter Control Register	74
2-89	VDP FIFO Word Count Register	75
2-90	VDP FIFO Interrupt Threshold Register	76
2-91	VDP FIFO Reset Register	76
2-92	VDP FIFO Output Control Register	76
2-93	VDP Line Number Interrupt Register	76
2-94	VDP Pixel Alignment Register	77

2-95	VDP Line Start Register	77
2-96	VDP Line Stop Register	77
2-97	VDP Global Line Mode Register	77
2-98	VDP Full Field Enable Register	78
2-99	VDP Full Field Mode Register	78
2-100	VBUS Data Access With No VBUS Address Increment Register	78
2-101	VBUS Data Access With VBUS Address Increment Register	78
2-102	FIFO Read Data Register	78
2-103	VBUS Address Register	79
2-104	Interrupt Raw Status 0 Register	79
2-105	Interrupt Raw Status 1 Register	80
2-106	Interrupt Status 0 Register	81
2-107	Interrupt Status 1 Register	82
2-108	Interrupt Mask 0 Register	83
2-109	Interrupt Mask 1 Register	84
2-110	Interrupt Clear 0 Register	85
2-111	Interrupt Clear 1 Register	86
2-112	VDP Closed Caption Data Register	86
2-113	VDP WSS Data Register	87
2-114	VDP VITC Data Register	87
2-115	VDP V-Chip TV Rating Block 1 Register	88
2-116	VDP V-Chip TV Rating Block 2 Register	88
2-117	VDP V-Chip TV Rating Block 3 Register	88
2-118	VDP V-Chip MPAA Rating Data Register	89
2-119	VDP General Line Mode and Line Address Register	90
2-120	VDP VPS/Gemstar Data Register	91
2-121	Analog Output Control 2 Register	92
2-122	Interrupt Configuration Register	92

NTSC/PAL/SECAM 2 11-Bit Digital Video Decoder With Macrovision™ Detection, YPbPr Inputs, and 5-Line Comb Filter

Check for Samples: [TVP5147M1](#)

1 Introduction

1.1 Features

- Two 30-MSPS 11-bit A/D channels with programmable gain control
- Supports NTSC (J, M, 4.43), PAL (B, D, G, H, I, M, N, Nc, 60), and SECAM (B, D, G, K, K1, L) CVBS, and S-video
- Supports analog component YPbPr video format with embedded sync
- Ten analog video input terminals for multisource connection
- Supports analog video output
- User-programmable video output formats
 - 10-bit ITU-R BT.656 4:2:2 YCbCr with embedded syncs
 - 10-bit 4:2:2 YCbCr with separate syncs
 - 20-bit 4:2:2 YCbCr with separate syncs
 - 2x sampled raw VBI data in active video during a vertical blanking period
 - Sliced VBI data during a vertical blanking period or active video period (full field mode)
- HSYNC/VSNC outputs with programmable position, polarity, width, and field ID (FID) output
- Composite and S-video processing
 - Adaptive 2-D 5-line adaptive comb filter for composite video inputs; chroma-trap available
 - Automatic video standard detection (NTSC/PAL/SECAM) and switching
 - Luma-peaking with programmable gain
 - Patented chroma transient improvement (CTI)
 - Patented architecture for locking to weak, noisy, or unstable signals
 - Single 14.31818-MHz reference crystal for all standards
 - Line-locked internal pixel sampling clock generation with horizontal and vertical lock signal outputs
 - Genlock output RTC format for downstream
- Certified Macrovision™ copy protection detection
- Available in commercial (0°C to 70°C) and industrial (–40°C to 85°C) temperature ranges
- Qualified for Automotive Applications (AEC-Q100 Rev G – TVP5147M1IPFPQ1 or TVP5147M1IPFPRQ1)
- VBI data processor
 - Teletext (NABTS, WST)
 - CC and extended data service (EDS)
 - Wide screen signaling (WSS)
 - Copy generation management system (CGMS)
 - Video program system (VPS/PDC)
 - Vertical interval time code (VITC)
 - Gemstar™ 1x/2x mode
 - V-Chip decoding
 - Register readback of CC, WSS (CGMS), VPS/PDC, VITC and Gemstar 1x/2x sliced data
- I²C host port interface
- Reduced power consumption: 1.8-V digital video encoder synchronization



Please be aware that an important notice concerning availability, standard warranty, and use in critical applications of Texas Instruments semiconductor products and disclaimers thereto appears at the end of this data sheet.

PowerPAD, DLP are trademarks of Texas Instruments.
 Gemstar is a trademark of Gemstar-TV Guide International.
 Macrovision is a trademark of Macrovision Corporation.
 All other trademarks are the property of their respective owners.

core, 3.3-V for digital I/O, and 1.8-V/3.3 V analog
core with power-save and power-down modes

- 80-terminal TQFP PowerPAD™ package

1.2 Description

The TVP5147M1 device is a high-quality, single-chip digital video decoder that digitizes and decodes all popular baseband analog video formats into digital component video. The TVP5147M1 decoder supports the analog-to-digital (A/D) conversion of component YPbPr signals, as well as the A/D conversion and decoding of NTSC, PAL, and SECAM composite and S-video into component YCbCr. This decoder includes two 11-bit 30-MSPS A/D converters (ADCs). Preceding each ADC in the device, the corresponding analog channel contains an analog circuit that clamps the input to a reference voltage and applies a programmable gain and offset. A total of ten video input terminals can be configured to a combination of YPbPr, CVBS, or S-video video inputs.

Composite or S-video signals are sampled at 2× the ITU-R BT.601 clock frequency, line-locked alignment, and are then decimated to the 1× pixel rate. CVBS decoding uses five-line adaptive comb filtering for both the luma and chroma data paths to reduce both cross-luma and cross-chroma artifacts. A chroma trap filter is also available. On CVBS and S-video inputs, the user can control video characteristics such as contrast, brightness, saturation, and hue via an I²C host port interface. Furthermore, luma peaking (sharpness) with programmable gain is included, as well as a patented chroma transient improvement (CTI) circuit.

The following output formats can be selected: 20-bit 4:2:2 YCbCr or 10-bit 4:2:2 YCbCr.

The TVP5147M1 decoder generates synchronization, blanking, field, active video window, horizontal and vertical syncs, clock, genlock (for downstream video encoder synchronization), host CPU interrupt and programmable logic I/O signals, in addition to digital video outputs.

The TVP5147M1 decoder includes methods for advanced vertical blanking interval (VBI) data retrieval. The VBI data processor (VDP) slices, parses, and performs error checking on teletext, closed caption (CC), and other VBI data. A built-in FIFO stores up to 11 lines of teletext data, and with proper host port synchronization, full-screen teletext retrieval is possible. The TVP5147M1 decoder can pass through the output formatter 2× sampled raw luma data for host-based VBI processing.

The main blocks of the TVP5147M1 decoder include:

- Robust sync detection for weak and noisy signals as well as VCR trick modes
- Y/C separation by 2-D 5-line adaptive comb or chroma trap filter
- Two 11-bit, 30-MSPS A/D converters with analog preprocessors [clamp and automatic gain control (AGC)]
- Analog video output
- Luminance processor
- Chrominance processor
- Clock/timing processor and power-down control
- Software-controlled power-saving standby mode
- Output formatter
- I²C host port interface
- VBI data processor
- Macrovision™ copy protection detection circuit (Type 1, 2, 3, and separate color stripe detection)
- 3.3-V tolerant digital I/O ports

1.3 Applications

- DLP™ projectors
- Digital TV
- LCD TV/monitors
- DVD recorders
- PVR
- PC video cards
- Video capture/video editing
- Video conferencing
- Automotive
- Industrial

1.4 Related Products

TVP5146M2 NTSC/PAL/SECAM 2 11-Bit Digital Video Decoder With Macrovision™ Detection, YPbPr/RGB Inputs, and 5-Line Comb Filter

TVP5150AM1 Ultralow Power NTSC/PAL/SECAM Video Decoder With Robust Sync Detector

1.5 Ordering Information

T_A	PACKAGED DEVICES⁽¹⁾ ⁽²⁾ 80-TERMINAL PLASTIC FLAT-PACK PowerPAD™ PACKAGE	PACKAGE OPTION
0°C to 70°C	TVP5147M1PFP	Tray
	TVP5147M1PFPR	Tape and reel
-40°C to 85°C	TVP5147M1IPFP	Tray
	TVP5147M1IPFPR	Tape and reel
	TVP5147M1IPFPQ1 ⁽³⁾	Tray
	TVP5147M1IPFPRQ1 ⁽³⁾	Tape and reel

(1) For the most current package and ordering information, see the Package Option Addendum at the end of this document, or see the TI web site at www.ti.com.

(2) Package drawings, standard packing quantities, thermal data, symbolization, and PCB design guidelines are available at www.ti.com/package.

(3) AEC-Q100 Rev G Certified

1.6 Functional Block Diagram

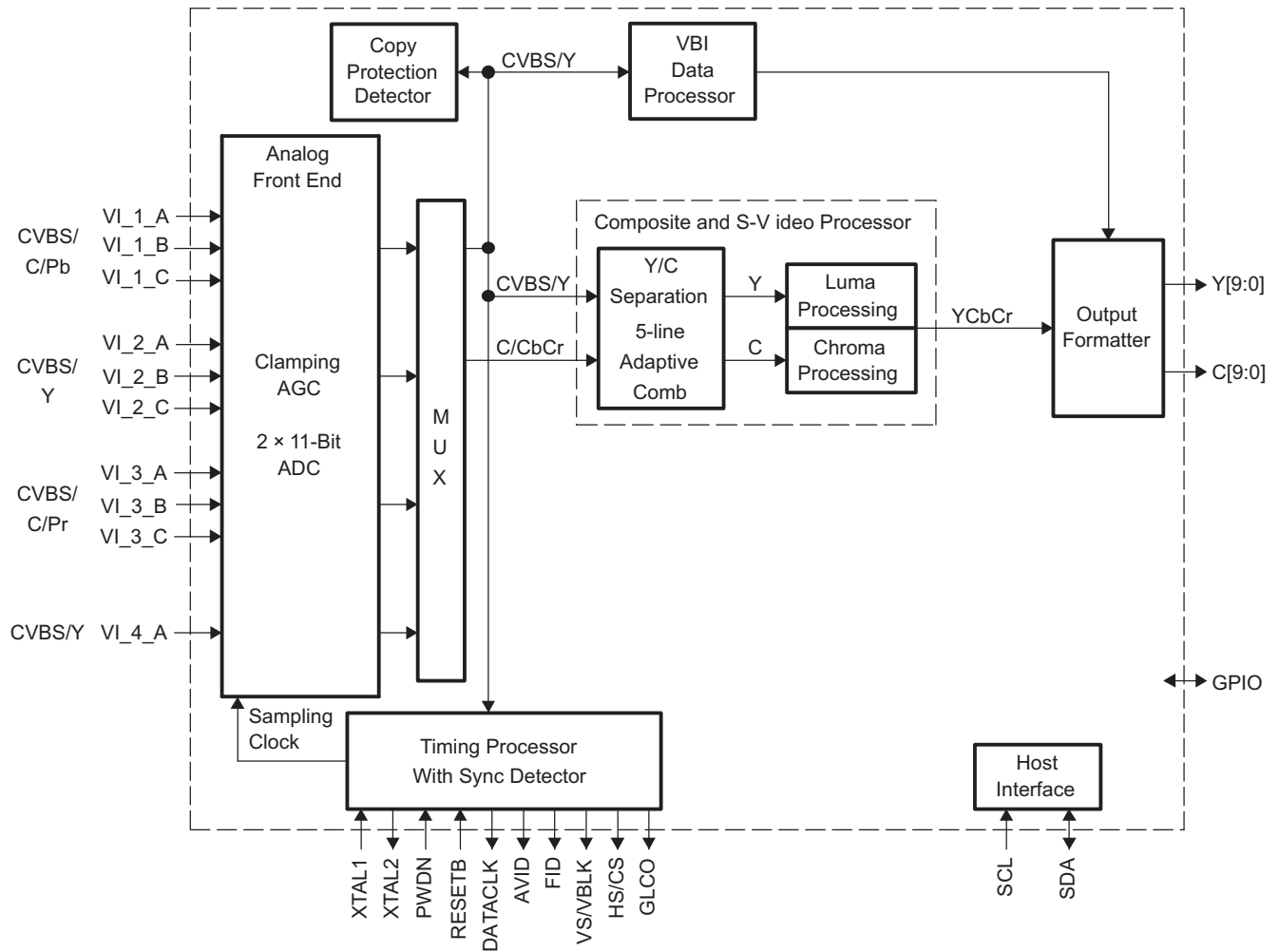

Figure 1-1. Functional Block Diagram

1.7 Terminal Assignments

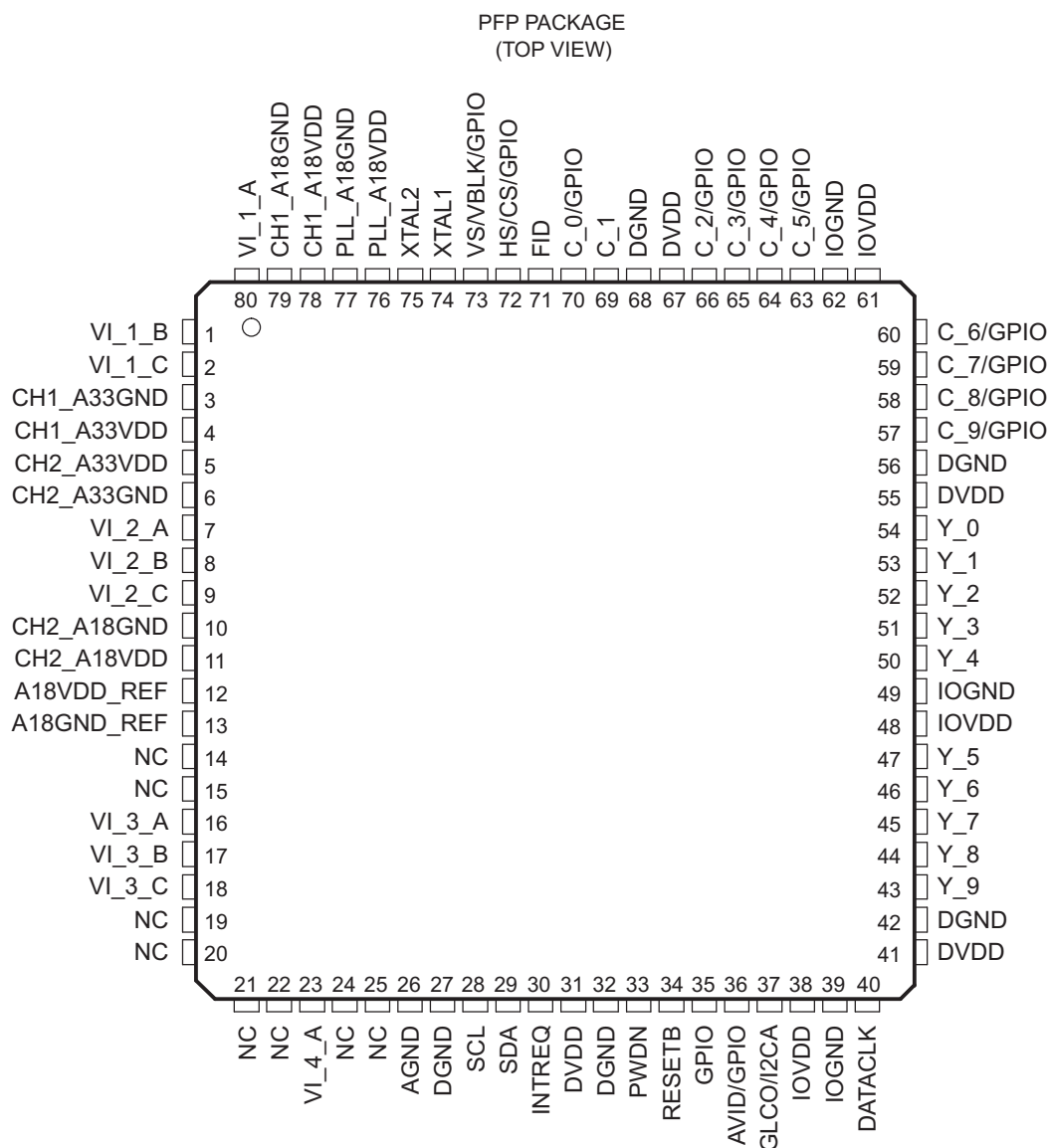

Figure 1-2. Terminal Assignments Diagram

1.8 Terminal Functions

Table 1-1. Terminal Functions

TERMINAL		I/O	DESCRIPTION
NAME	NO.		
Analog Video			
VI_1_A	80	I/O	VI_1_A: Analog video input for CVBS/Pb/C or analog video output (see Table 2-79) VI_1_x: Analog video input for CVBS/Pb/C VI_2_x: Analog video input for CVBS/Y VI_3_x: Analog video input for CVBS/Pr/C VI_4_A: Analog video input for CVBS/Y Up to ten composite, four S-video, and two composite or three component video inputs (or a combination thereof) can be supported. The inputs must be ac-coupled. The recommended coupling capacitor is 0.1 μ F. The possible input configurations are listed in the input select register at I ² C subaddress 00h (see Table 2-12).
VI_1_B	1	I	
VI_1_C	2	I	
VI_2_A	7	I	
VI_2_B	8	I	
VI_2_C	9	I	
VI_3_A	16	I	
VI_3_B	17	I	
VI_3_C	18	I	
VI_4_A	23	I	
Clock Signals			
DATACLK	40	O	Line-locked data output clock
XTAL1	74	I	External clock reference input. It can be connected to an external oscillator with a 1.8-V compatible clock signal or a 14.31818-MHz crystal oscillator.
XTAL2	75	O	External clock reference output. Not connected if XTAL1 is driven by an external single-ended oscillator.
Digital Video			
C_[9:0]	57, 58, 59, 60, 63, 64, 65, 66, 69, 70	I/O	Digital video output of CbCr, C[9] is MSB and C[0] is LSB. C_0 and C_[9-2] can be used as programmable general purpose I/O. C_1 (pin 69) requires an external pulldown resistor and should not be used for general purpose I/O. For the 8-bit mode, the two LSBs are ignored. Unused outputs can be left unconnected.
Y[9:0]	43, 44, 45, 46, 47, 50, 51, 52, 53, 54	O	Digital video output of Y/YCbCr, Y[9] is MSB and Y[0] is LSB. For the 8-bit mode, the two LSBs are ignored. Unused outputs can be left unconnected.
Miscellaneous Signals			
GPIO	35	I/O	Programmable general-purpose I/O
GLCO/I2CA	37	I/O	Genlock control output (GLCO) uses real time control (RTC) format. During reset, this terminal is an input used to program the I ² C address LSB.
INTREQ	30	O	Interrupt request
NC	14, 15, 19, 20, 21, 22, 24, 25		Not connected. These terminals can be connected to power or ground (compatible with TVP5146 terminals), internally floating.
PWDN	33	I	Power down input: 1 = Power down 0 = Normal mode
RESETB	34	I	Reset input, active low (see Section 2.8)
Host Interface			
SCL	28	I	I ² C clock input
SDA	29	I/O	I ² C data bus
Power Supplies			
AGND	26		Analog ground. Connect to analog ground.
A18GND_REF	13		Analog 1.8-V return
A18VDD_REF	12		Analog power for reference 1.8 V
CH1_A18GND	79		Analog 1.8-V return
CH2_A18GND	10		
CH1_A18VDD	78		Analog power. Connect to 1.8 V.

Table 1-1. Terminal Functions (continued)

TERMINAL		I/O	DESCRIPTION
NAME	NO.		
CH2_A18VDD	11		
CH1_A33GND	3		Analog 3.3-V return
CH2_A33GND	6		
CH1_A33VDD	4		Analog power. Connect to 3.3 V.
CH2_A33VDD	5		
DGND	27, 32, 42, 56, 68		Digital return
DVDD	31, 41, 55, 67		Digital power. Connect to 1.8 V.
IOGND	39, 49, 62		Digital power return
IOVDD	38, 48, 61		Digital power. Connect to 3.3 V or less for reduced noise.
PLL_A18GND	77		Analog power return
PLL_A18VDD	76		Analog power. Connect to 1.8 V.
Sync Signals			
HS/CS/GPIO	72	I/O	Horizontal sync output or digital composite sync output Programmable general-purpose I/O
VS/VBLK/GPIO	73	I/O	Vertical sync output (for modes with dedicated VSYNC) or VBLK output Programmable general-purpose I/O
FID	71	I/O	Odd/even field indicator output. This terminal needs a pulldown resistor (see Figure 5-1).
AVID/GPIO	36	I/O	Active video indicator output Programmable general-purpose I/O

2 Functional Description

2.1 Analog Processing and A/D Converters

Figure 2-1 shows a functional diagram of the analog processors and A/D converters, which provide the analog interface to all video inputs. It accepts up to ten inputs and performs source selection, video clamping, video amplification, A/D conversion, and gain and offset adjustments to center the digitized video signal. The TVP5147M1 supports one analog video output for the selected analog input video.

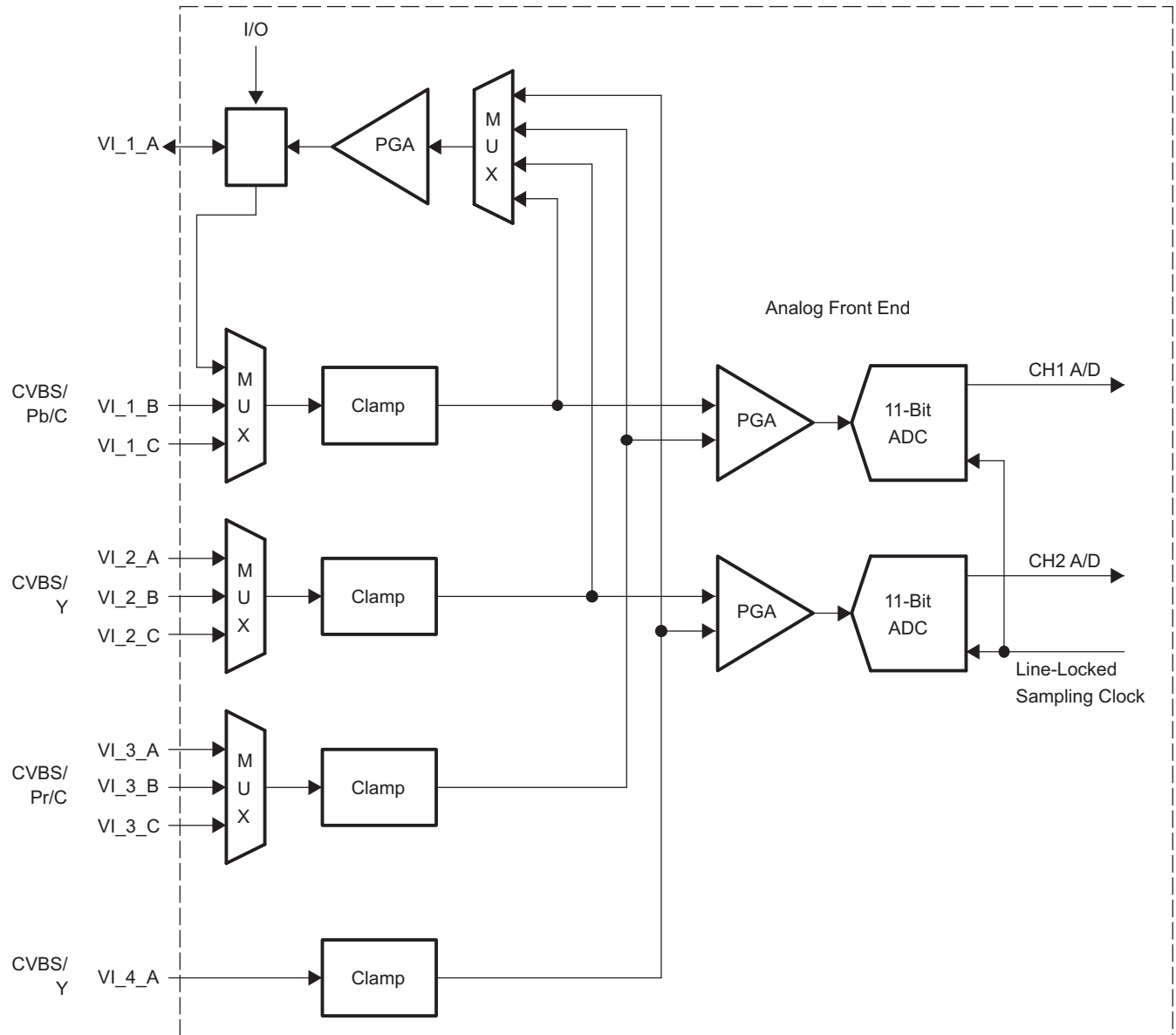

Figure 2-1. Analog Processors and A/D Converters

2.1.1 Video Input Switch Control

The TVP5147M1 decoder has two analog channels that accept up to ten video inputs. The user can configure the internal analog video switches via the I²C interface. The ten analog video inputs can be used for different input configurations, some of which are:

- Up to ten selectable individual composite video inputs
- Up to four selectable S-video inputs
- Up to three selectable analog YPbPr video inputs and one CVBS input
- Up to two selectable analog YPbPr video inputs, one S-video input, and two CVBS inputs

The input selection is performed by the input select register at I²C subaddress 00h (see [Table 2-12](#)).

2.1.2 Analog Input Clamping

An internal clamping circuit restores the ac-coupled video signal to a fixed dc level. The clamping circuit provides line-by-line restoration of the video sync level to a fixed dc reference voltage. The selection between bottom and mid clamp is performed automatically by the TVP5147M1 decoder.

2.1.3 Automatic Gain Control

The TVP5147M1 decoder uses two programmable gain amplifiers (PGAs), one per channel. The PGA can scale a signal with a voltage-input compliance of 0.5-V_{PP} to 2.0-V_{PP} to a full-scale 10-bit A/D output code range. A 4-bit code sets the coarse gain with individual adjustment per channel. Minimum gain corresponds to a code 0x0 (2.0-V_{PP} full-scale input, -6-dB gain) while maximum gain corresponds to code 0xF (0.5 V_{PP} full scale, +6-dB gain). The TVP5147M1 decoder also has 12-bit fine gain controls for each channel and applies independently to coarse gain controls. For composite video, the input video signal amplitude can vary significantly from the nominal level of 1 V_{PP}. The TVP5147M1 decoder can adjust its PGA setting automatically: an automatic gain control (AGC) can be enabled and can adjust the signal amplitude such that the maximum range of the ADC is reached without clipping. Some nonstandard video signals contain peak white levels that saturate the ADC. In these cases, the AGC automatically cuts back gain to avoid clipping. If the AGC is on, then the TVP5147M1 decoder can read the gain currently being used.

The TVP5147M1 AGC comprises the front-end AGC before Y/C separation and the back-end AGC after Y/C separation. The back-end AGC restores the optimum system gain whenever an amplitude reference such as the composite peak (which is only relevant before Y/C separation) forces the front-end AGC to set the gain too low. The front-end and back-end AGC algorithms can use up to four amplitude references: sync height, color burst amplitude, composite peak, and luma peak.

The specific amplitude references being used by the front-end and back-end AGC algorithms can be independently controlled using the AGC white peak processing register located at subaddress 74h. The TVP5147M1 gain increment speed and gain increment delay can be controlled using the AGC increment speed register located at subaddress 78h and the AGC increment delay register located at subaddress 79h.

2.1.4 Analog Video Output

One of the analog input signals is available at the analog video output terminal, which is shared with input selected by I²C registers. The signal at this terminal must be buffered by a source follower. The nominal output voltage is 2 V p-p, thus the signal can be used to drive a 75-Ω line. The magnitude is maintained with an AGC in 16 steps controlled by the TVP5147M1 decoder. To use this function, terminal VI_1_A must be set as an output terminal. The input mode selection register also selects an active analog output signal.

2.1.5 A/D Converters

All ADCs have a resolution of 11 bits and can operate up to 30 MSPS. All A/D channels receive an identical clock from the on-chip phase-locked loop (PLL) at a frequency between 24 MHz and 30 MHz. All ADC reference voltages are generated internally.

2.2 Digital Video Processing

Figure 2-2 is a block diagram of the TVP5147M1 digital video decoder processing. This block receives digitized video signals from the ADCs and performs composite processing for CVBS and S-video inputs and YCbCr signal enhancements for CVBS and S-video inputs. It also generates horizontal and vertical syncs and other output control signals such as genlock for CVBS and S-video inputs. Additionally, it can provide field identification, horizontal and vertical lock, vertical blanking, and active video window indication signals. The digital data output can be programmed to two formats: 20-bit 4:2:2 with external syncs or 10-bit 4:2:2 with embedded/separate syncs. The circuit detects pseudosync pulses, AGC pulses, and color striping in Macrovision-encoded copy-protected material. Information present in the VBI interval can be retrieved and either inserted in the ITU-R BT.656 output as ancillary data or stored in internal FIFO and/or registers for retrieval via the host port interface.

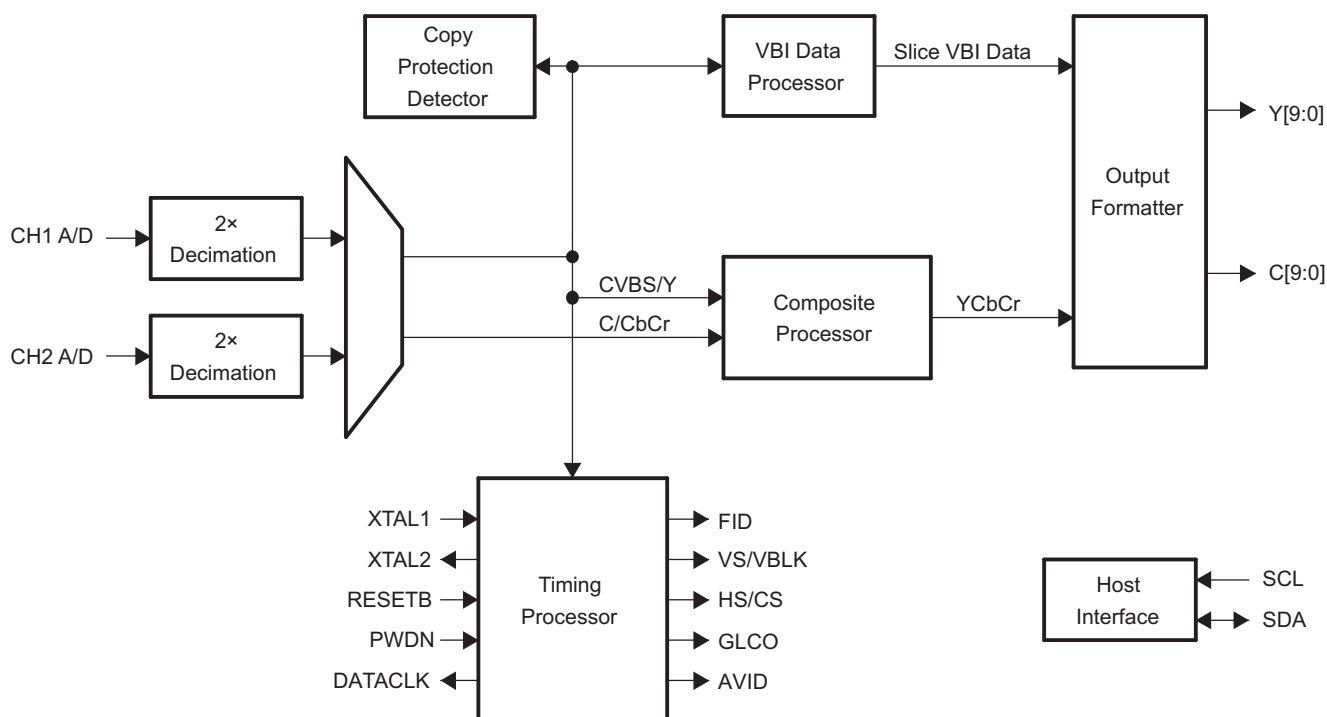

Figure 2-2. Digital Video Processing Block Diagram

2.2.1 2x Decimation Filter

All input signals are typically oversampled by a factor of 2 (27 MHz). The A/D outputs initially pass through decimation filters that reduce the data rate to 1x the pixel rate. The decimation filter is a half-band filter. Oversampling and decimation filtering can effectively increase the overall signal-to-noise ratio by 3 dB.

2.2.2 Composite Processor

Figure 2-3 is a block diagram of the TVP5147M1 digital composite video processing circuit. This processing circuit receives a digitized composite or S-video signal from the ADCs and performs Y/C separation (bypassed for S-video input), chroma demodulation for PAL/NTSC and SECAM, and YUV signal enhancements.

The 10-bit composite video is multiplied by the subcarrier signals in the quadrature demodulator to generate color difference signals U and V. The U and V signals are then sent to low-pass filters to achieve the desired bandwidth. An adaptive 5-line comb filter separates UV from Y based on the unique property of color phase shifts from line to line. The chroma is remodulated through a quadrature modulator and subtracted from line-delayed composite video to generate luma. This form of Y/C separation is completely complementary, thus there is no loss of information. However, in some applications, it is desirable to limit the U/V bandwidth to avoid crosstalk. In that case, notch filters can be turned on. To accommodate some viewing preferences, a peaking filter is also available in the luma path. Contrast, brightness, saturation, hue, and saturation controls are programmable through the host port.

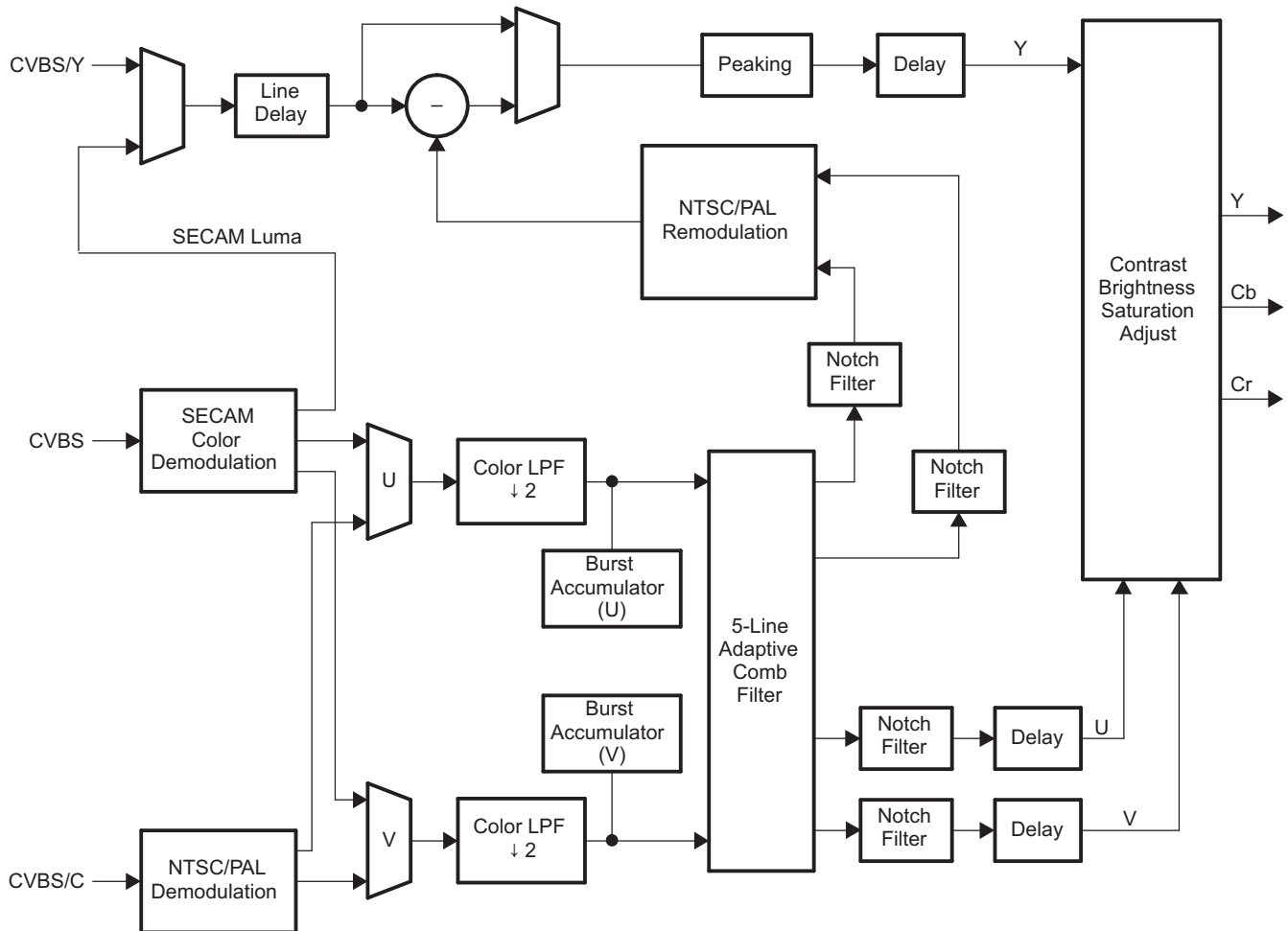

Figure 2-3. Composite and S-Video Processing Block Diagram

2.2.2.1 Color Low-Pass Filter

High filter bandwidth preserves sharp color transitions and produces crisp color boundaries. However, for nonstandard video sources that have asymmetrical U and V side bands, it is desirable to limit the filter bandwidth to avoid UV crosstalk. The color low-pass filter bandwidth is programmable to enable one of the three notch filters. Figure 2-4 and Figure 2-5 represent the frequency responses of the wideband color low-pass filters.

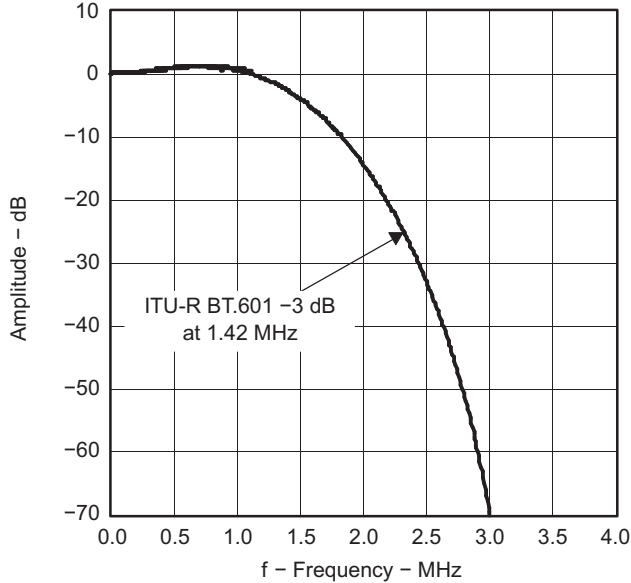

Figure 2-4. Color Low-Pass Filter Frequency Response

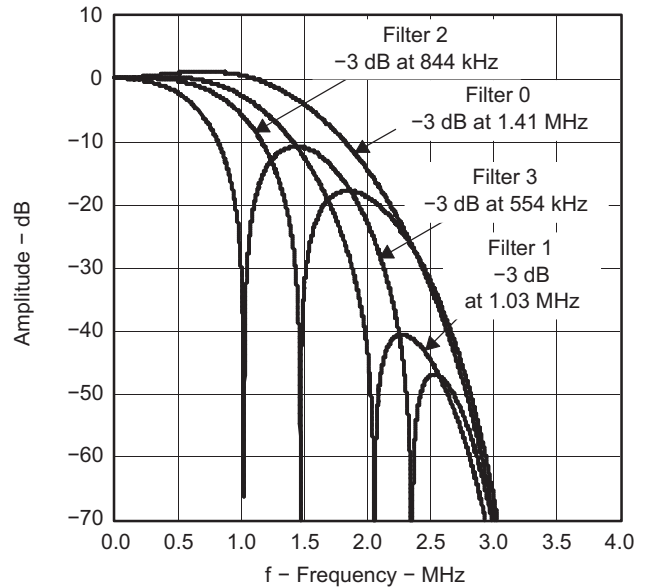

Figure 2-5. Color Low-Pass Filter With Filter Characteristics, NTSC/PAL ITU-R BT.601 Sampling

2.2.2.2 Y/C Separation

Y/C separation can be done using adaptive 5-line (5-H delay) comb filters or a chroma trap filter. The comb filter can be selectively bypassed in the luma or chroma path. If the comb filter is bypassed in the luma path, then chroma trap filters are used which are shown in Figure 2-6 and Figure 2-7. The TI patented adaptive comb filter algorithm reduces artifacts such as hanging dots at color boundaries. It detects and properly handles false colors in high-frequency luminance images such as a multiburst pattern or circle pattern.

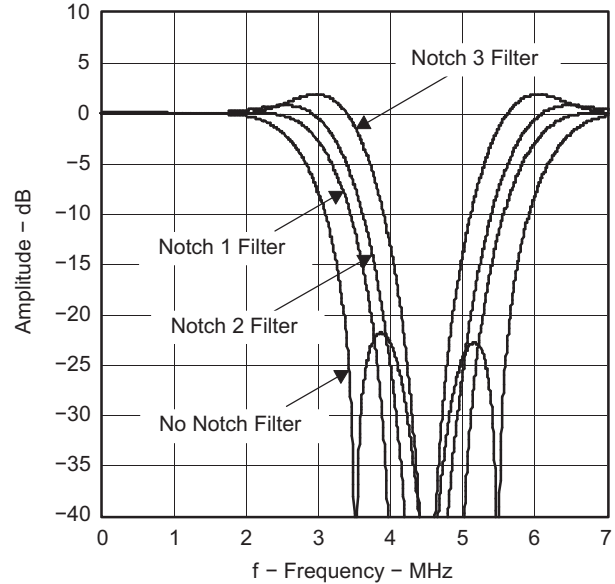
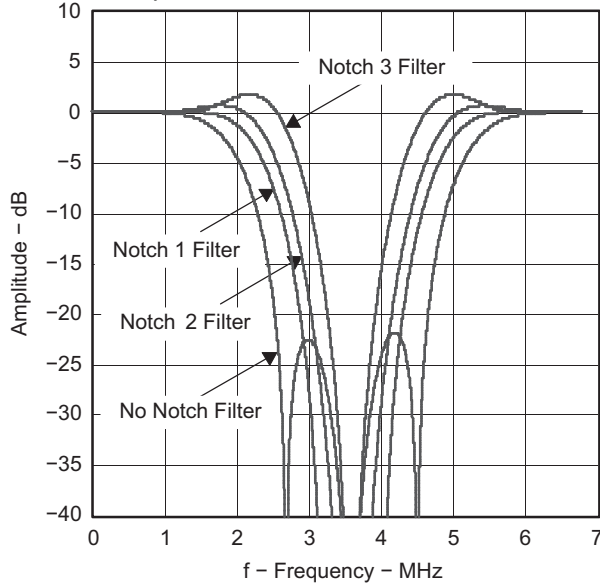

Figure 2-6. Chroma Trap Filter Frequency Response, Figure 2-7. Chroma Trap Filter Frequency Response, NTSC ITU-R BT.601 Sampling
NTSC ITU-R BT.601 Sampling
PAL ITU-R BT.601 Sampling

2.2.3 Luminance Processing

The digitized composite video signal passes through either a luminance comb filter or a chroma trap filter, either of which removes chrominance information from the composite signal to generate a luminance signal. The luminance signal is then fed into the input of a peaking circuit. Figure 2-8 illustrates the basic functions of the luminance data path. In the case of S-video, the luminance signal bypasses the comb filter or chroma trap filter and is fed directly to the circuit. A peaking filter (edge enhancer) amplifies high-frequency components of the luminance signal. Figure 2-9 shows the characteristics of the peaking filter at four different gain settings that are user-programmable via the I²C interface.

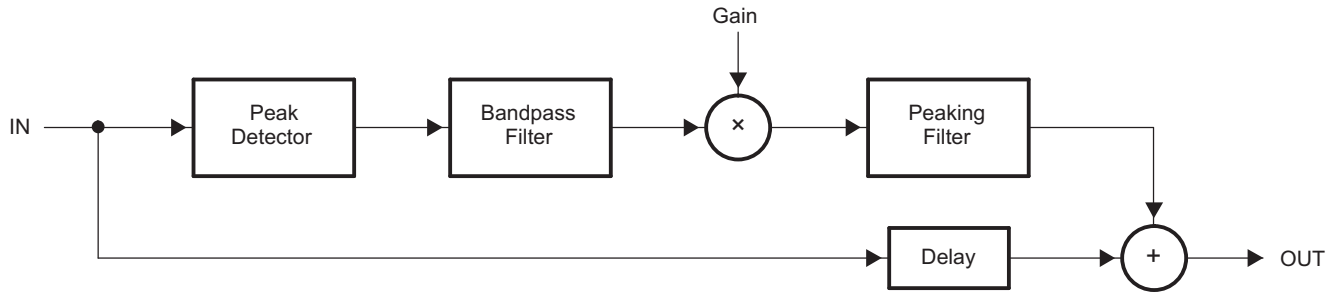

Figure 2-8. Luminance Edge-Enhancer Peaking Block Diagram

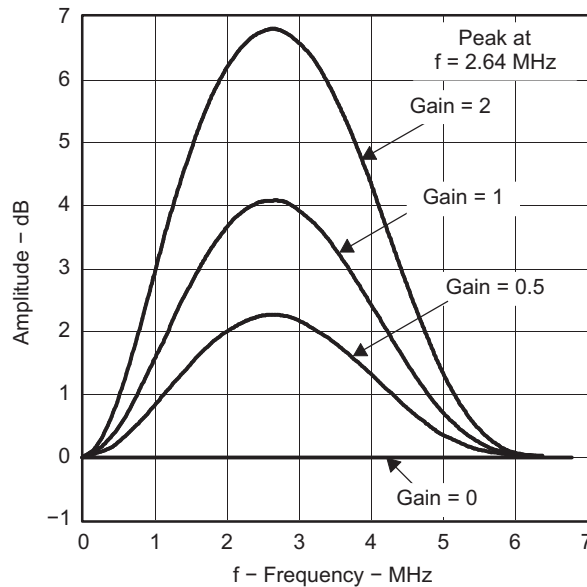

Figure 2-9. Peaking Filter Response, NTSC/PAL ITU-R BT.601 Sampling

2.2.4 Color Transient Improvement

Color transient improvement (CTI) enhances horizontal color transients. The color difference signal transition points are maintained, but the edges are enhanced for signals that have bandwidth-limited color components.

2.3 Clock Circuits

An internal line-locked PLL generates the system and pixel clocks. A 14.318-MHz clock is required to drive the PLL. This can be input to the TVP5147M1 decoder at the 1.8-V level on terminal 74 (XTAL1), or a crystal of 14.318-MHz fundamental resonant frequency can be connected across terminals 74 and 75 (XTAL2). If a parallel resonant circuit is used as shown in Figure 2-10, then the external capacitors must have the following relationship:

$$C_{L1} = C_{L2} = 2C_L - C_{STRAY} \quad (1)$$

Where,

C_{STRAY} is the terminal capacitance with respect to ground

C_L is the crystal load capacitance specified by the crystal manufacturer

Figure 2-10 shows the reference clock configurations. The TVP5147M1 decoder generates the DATACLK signal used for clocking data.

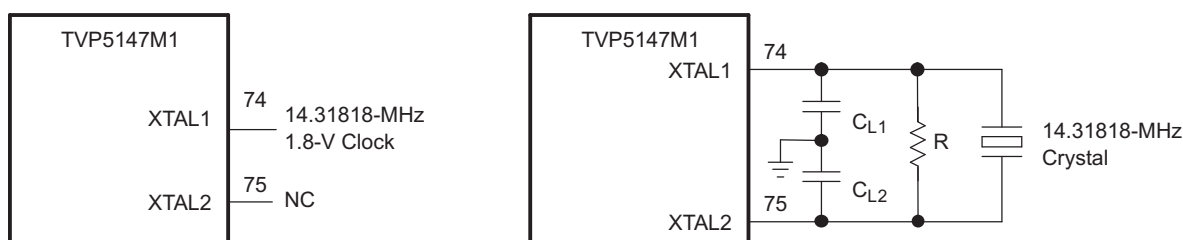

NOTE: The resistor (R) in parallel with the crystal is recommended to support a wide range of crystal types. A 100-k Ω resistor may be used for most crystal types.

Figure 2-10. Reference Clock Configurations

2.4 Real-Time Control (RTC)

Although the TVP5147M1 decoder is a line-locked system, the color burst information is used to determine accurately the color subcarrier frequency and phase. This ensures proper operation with nonstandard video signals that do not follow exactly the required frequency multiple between color subcarrier frequency and video line frequency. The frequency control word of the internal color subcarrier PLL and the subcarrier reset bit are transmitted via terminal 37 (GLCO) for optional use in an end system (for example, by a video encoder). The frequency control word is a 23-bit binary number. The instantaneous frequency of the color subcarrier can be calculated using the following equation:

$$F_{PLL} = (F_{ctrl} / 2^{23}) \times F_{sclk} \quad (2)$$

Where,

F_{PLL} is the frequency of the subcarrier PLL

F_{ctrl} is the 23-bit PLL frequency control word

F_{sclk} is two times the pixel frequency

This information can be generated on the GLCO terminal. Figure 2-11 shows the detailed timing diagram.

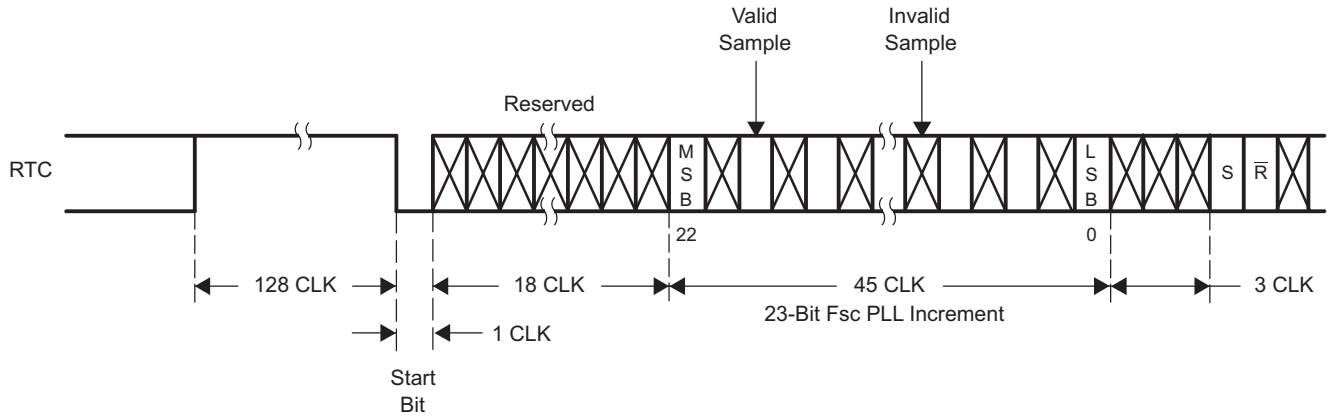

NOTE: RTC reset bit (\bar{R}) is active-low, Sequence bit (S) PAL: 1 = (R-Y) line normal, 0 = (R-Y) line inverted, NTSC: 1 = no change

Figure 2-11. RTC Timing

2.5 Output Formatter

The output formatter sets how the data is formatted for output on the TVP5147M1 output buses. Table 2-1 shows the available output modes.

Table 2-1. Output Format

TERMINAL NAME	TERMINAL NUMBER	10-Bit 4:2:2 YCbCr	20-Bit 4:2:2 YCbCr
Y_9	43	Cb9, Y9, Cr9	Y9
Y_8	44	Cb8, Y8, Cr8	Y8
Y_7	45	Cb7, Y7, Cr7	Y7
Y_6	46	Cb6, Y6, Cr6	Y6
Y_5	47	Cb5, Y5, Cr5	Y5
Y_4	50	Cb4, Y4, Cr4	Y4
Y_3	51	Cb3, Y3, Cr3	Y3
Y_2	52	Cb2, Y2, Cr2	Y2
Y_1	53	Cb1, Y1, Cr1	Y1
Y_0	54	Cb0, Y0, Cr0	Y0
C_9	57		Cb9, Cr9
C_8	58		Cb8, Cr8
C_7	59		Cb7, Cr7
C_6	60		Cb6, Cr6
C_5	63		Cb5, Cr5
C_4	64		Cb4, Cr4
C_3	65		Cb3, Cr3
C_2	66		Cb2, Cr2
C_1	69		Cb1, Cr1
C_0	70		Cb0, Cr0

Table 2-2. Summary of Line Frequencies, Data Rates, and Pixel/Line Counts

STANDARDS	PIXELS PER LINE	ACTIVE PIXELS PER LINE	LINES PER FRAME	PIXEL FREQUENCY (MHz)	COLOR SUBCARRIER FREQUENCY (MHz)	HORIZONTAL LINE RATE (kHz)
601 Sampling						
NTSC-J, M	858	720	525	13.5	3.579545	15.73426
NTSC-4.43	858	720	525	13.5	4.43361875	15.73426
PAL-M	858	720	525	13.5	3.57561149	15.73426
PAL-60	858	720	525	13.5	4.43361875	15.73426
PAL-B, D, G, H, I	864	720	625	13.5	4.43361875	15.625
PAL-N	864	720	625	13.5	4.43361875	15.625
PAL-Nc	864	720	625	13.5	3.58205625	15.625
SECAM	864	720	625	13.5	Dr = 4.406250 Db = 4.250000	15.625

2.5.1 Separate Syncs

VS, HS, and VBLK are independently software programmable to a 1× pixel count. This allows any possible alignment to the internal pixel count and line count. The default settings for 525-line and 625-line video outputs are given as examples below. FID changes at the same transient time when the trailing edge of vertical sync occurs. The polarity of FID is programmable by an I²C interface.

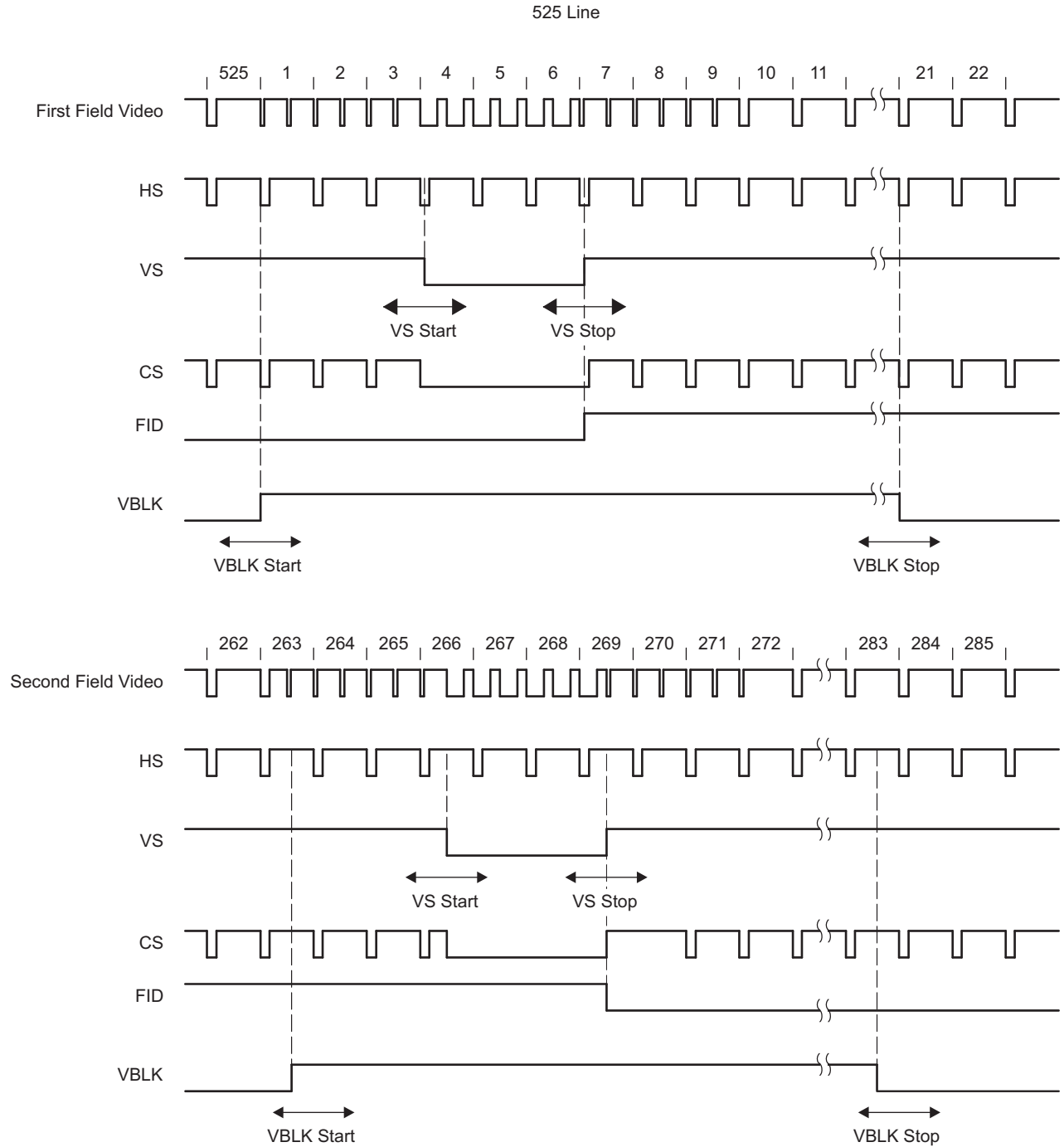

NOTE: Line numbering conforms to ITU-R BT.470.

Figure 2-12. Vertical Synchronization Signals for 525-Line System

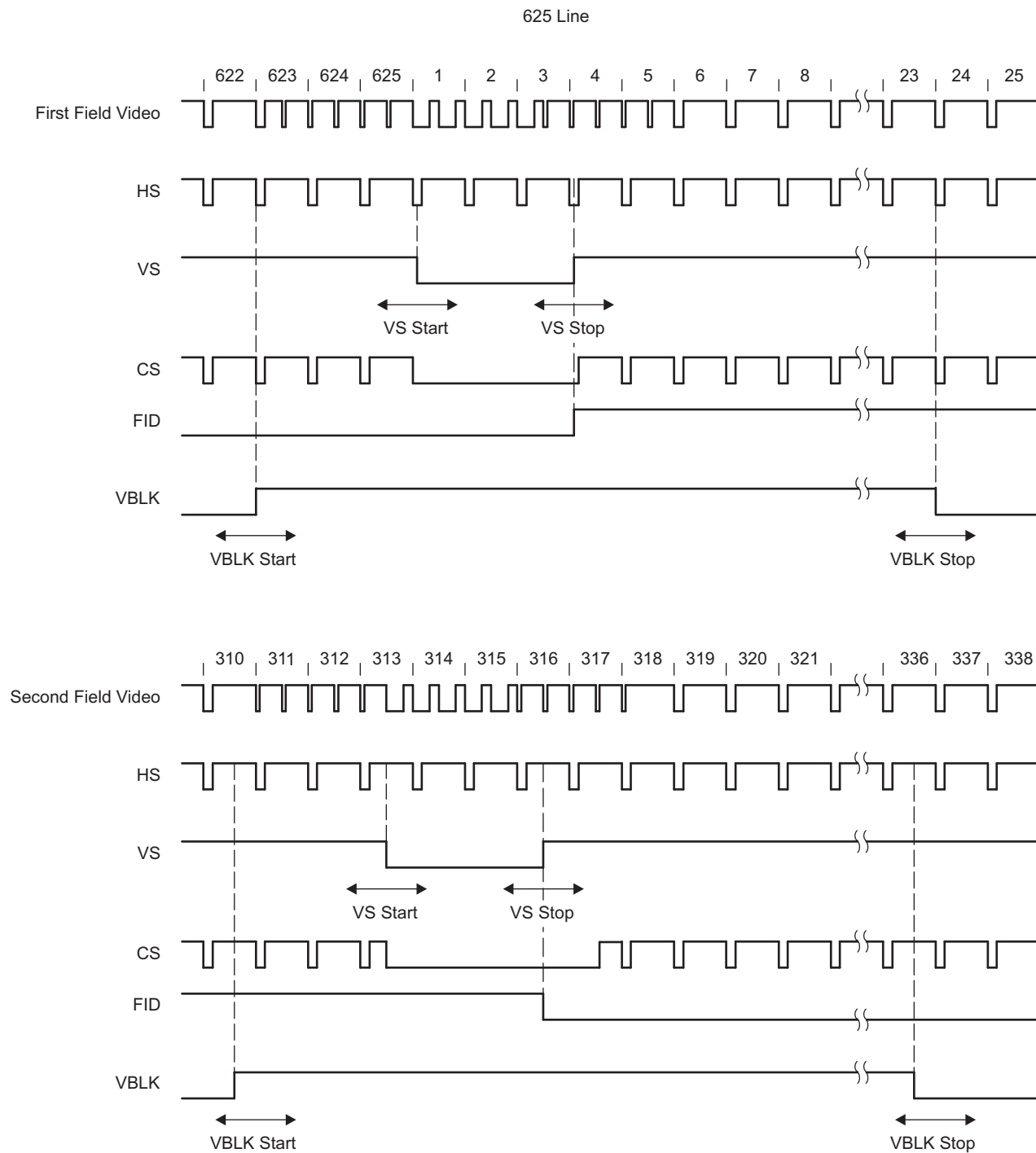

NOTE: Line numbering conforms to ITU-R BT.470.

Figure 2-13. Vertical Synchronization Signals for 625-Line System

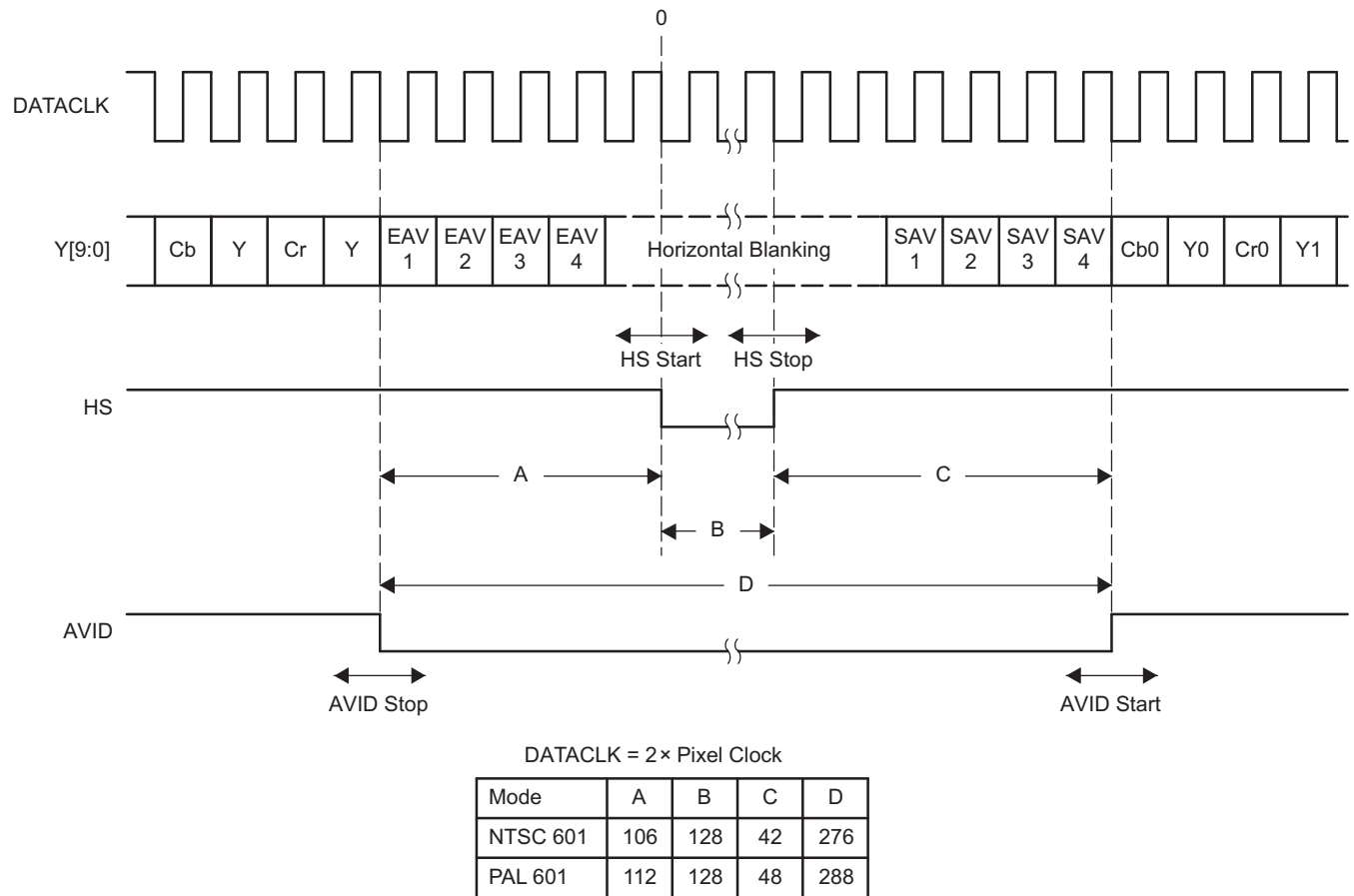

NOTE: ITU-R BT.656 10-bit 4:2:2 timing with 2x pixel clock reference

Figure 2-14. Horizontal Synchronization Signals for 10-Bit 4:2:2 Mode

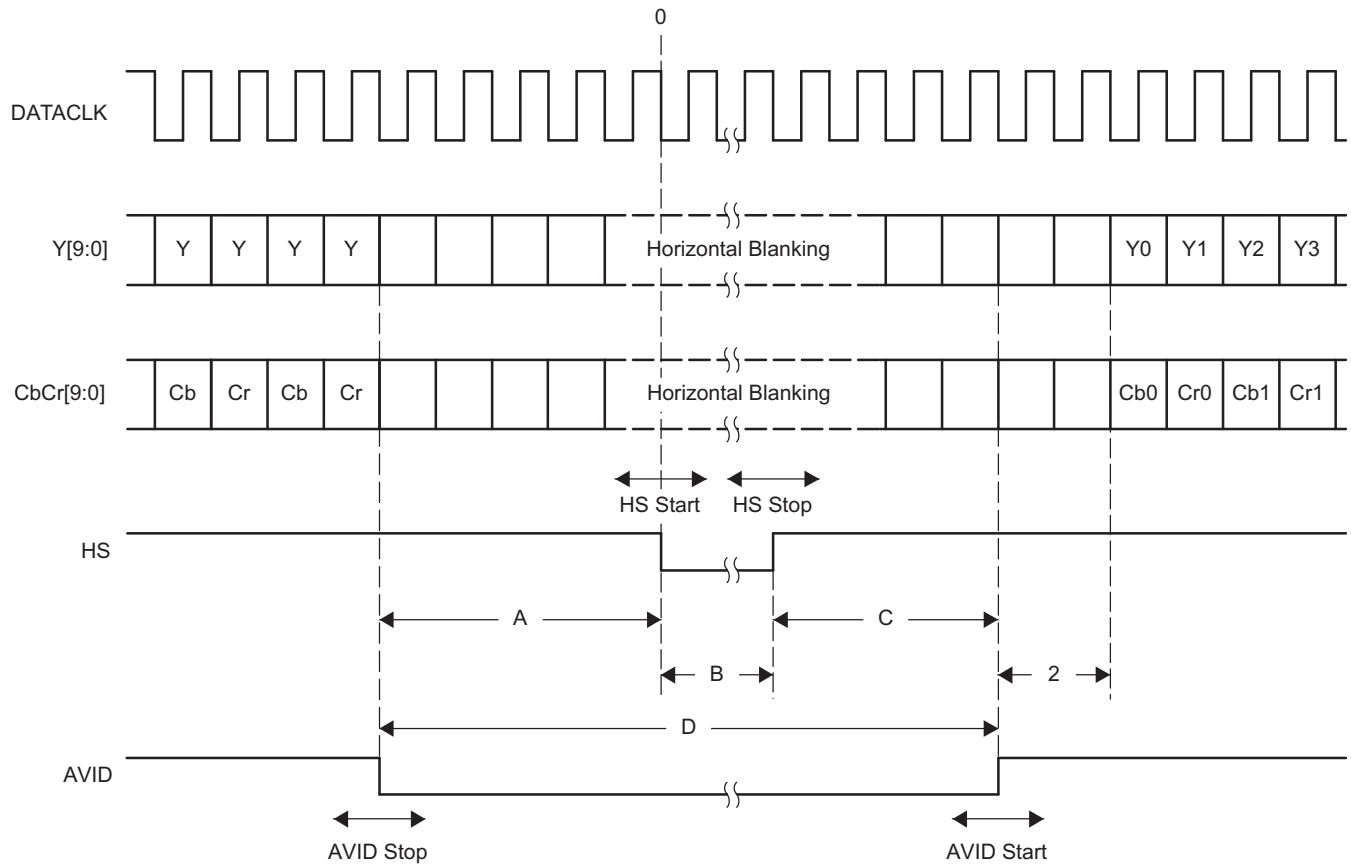

NOTE: AVID rising edge occurs four clock cycles early

DATACLK = 1 × Pixel Clock

Mode	A	B	C	D
NTSC 601	53	64	19	136
PAL 601	56	64	22	142

NOTE: 20-bit 4:2:2 timing with 1× pixel clock reference

Figure 2-15. Horizontal Synchronization Signals for 20-Bit 4:2:2 Mode

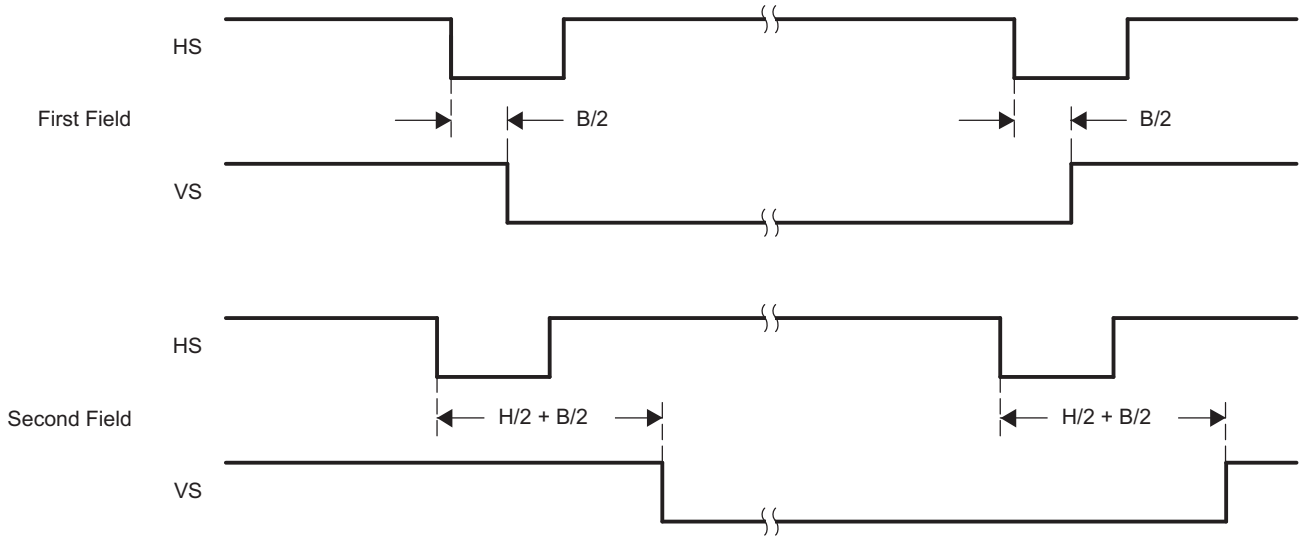

	10-Bit (PCLK = 2 × Pixel Clock)		20-Bit (PCLK = 1 × Pixel Clock)	
Mode	B/2	H/2	B/2	H/2
NTSC 601	64	858	32	429
PAL 601	64	864	32	432

Figure 2-16. VSYNC Position With Respect to HSYNC

2.5.2 Embedded Syncs

Standards with embedded syncs insert the SAV and EAV codes into the data stream on the rising and falling edges of AVID. These codes contain the V and F bits, which also define vertical timing. Table 2-3 gives the format of the SAV and EAV codes.

H equals 1 always indicates EAV. H equals 0 always indicates SAV. The alignment of V and F to the line and field counter varies depending on the standard.

The P bits are protection bits:

$$P3 = V \text{ xor } H; P2 = F \text{ xor } H; P1 = F \text{ xor } V; P0 = F \text{ xor } V \text{ xor } H$$

Table 2-3. EAV and SAV Sequence

	D9 (MSB)	D8	D7	D6	D5	D4	D3	D2	D1	D0
Preamble	1	1	1	1	1	1	1	1	1	1
Preamble	0	0	0	0	0	0	0	0	0	0
Preamble	0	0	0	0	0	0	0	0	0	0
Status word	1	F	V	H	P3	P2	P1	P0	0	0

2.6 I²C Host Interface

Communication with the TVP5147M1 decoder is via an I²C host interface. The I²C standard consists of two signals, the serial input/output data (SDA) line and the serial input clock line (SCL), which carry information between the devices connected to the bus. A third signal (I2CA) is used for slave address selection. Although an I²C system can be multimastered, the TVP5147M1 decoder functions as a slave device only.

Because SDA and SCL are kept open drain at a logic-high output level or when the bus is not driven, the user must connect SDA and SCL to a positive supply voltage via a pullup resistor on the board. The slave addresses select signal, terminal 37 (I2CA), enables the use of two TVP5147M1 devices tied to the same I²C bus, because it controls the least-significant bit of the I²C device address.

Table 2-4. I²C Host Interface Terminal Description

SIGNAL	TYPE	DESCRIPTION
I2CA	I	Slave address selection
SCL	I	Input clock line
SDA	I/O	Input/output data line

2.6.1 Reset and I²C Bus Address Selection

The TVP5147M1 decoder can respond to two possible chip addresses. The address selection is made at reset by an externally supplied level on the I2CA terminal. The TVP5147M1 decoder samples the level of terminal 37 at power up or at the trailing edge of RESETB and configures the I²C bus address bit A0.

Table 2-5. I²C Address Selection

A6	A5	A4	A3	A2	A1	A0 (I2CA)	R/W	HEX
1	0	1	1	1	0	0 (default)	1/0	B9/B8
1	0	1	1	1	0	1 ⁽¹⁾	1/0	BB/BA

(1) If terminal 37 is strapped to DVDD via a 2.2-kΩ resistor, I²C device address A0 is set to 1.

2.6.2 I²C Operation

Data transfers occur using the following illustrated formats.

S	10111000	ACK	Subaddress	ACK	Send Data	ACK	P
---	----------	-----	------------	-----	-----------	-----	---

Read from I²C control registers

S	10111000	ACK	Subaddress	ACK	S	10111001	ACK	Receive Data	NAK	P
---	----------	-----	------------	-----	---	----------	-----	--------------	-----	---

S = I²C bus start condition

P = I²C bus stop condition

ACK = Acknowledge generated by the slave

NAK = Acknowledge generated by the master, for multiple-byte read master with ACK each byte except last byte

Subaddress = Subaddress byte

Data = Data byte. If more than one byte of data is transmitted (read and write), the subaddress pointer is automatically incremented.

I²C bus address = Example shown that I2CA is in default mode. Write (B8h), read (B9h)

2.6.3 VBUS Access

The TVP5147M1 decoder has additional internal registers accessible through an indirect access to an internal 24-bit address wide VBUS. Figure 2-17 shows the VBUS register access.

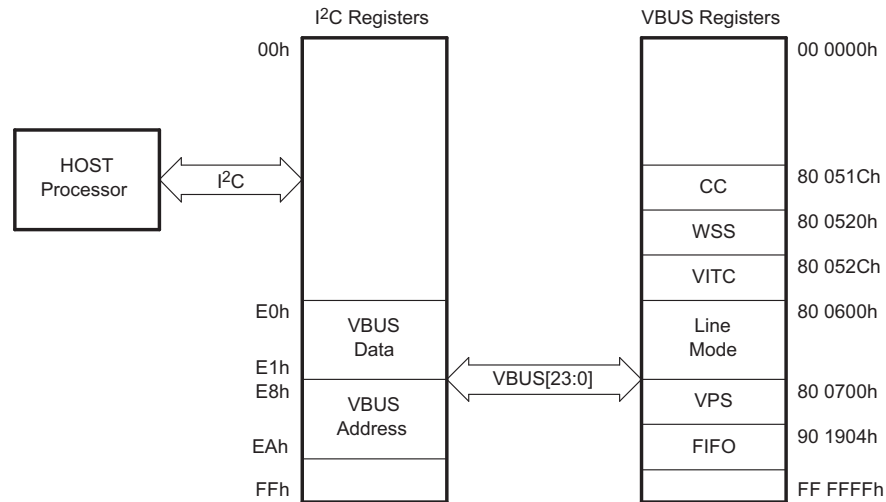

VBUS Write

Single Byte

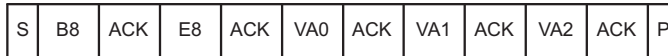

Multiple Bytes

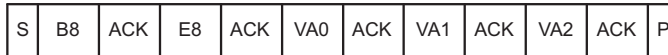

VBUS Read

Single Byte

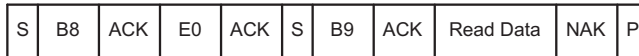
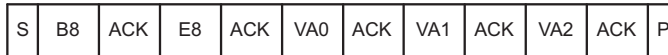

Multiple Bytes

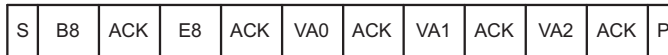

NOTE: Examples use default PC address
 ACK = Acknowledge generated by the slave
 NAK = No acknowledge generated by the master

Figure 2-17. VBUS Access

2.7 VBI Data Processor

The TVP5147M1 VBI data processor (VDP) slices various data services like teletext (WST, NABTS), closed caption (CC), wide screen signaling (WSS), program delivery control (PDC), vertical interval time code (VITC), video program system (VPS), copy generation management system (CGMS) data, and electronic program guide (Gemstar) 1x/2x. [Table 2-6](#) shows the supported VBI system.

These services are acquired by programming the VDP to enable the reception of one or more vertical blank interval (VBI) data standard(s) during the VBI. The VDP can be programmed on a line-per-line basis to enable simultaneous reception of different VBI formats, one per line. The results are stored in a FIFO and/or registers. Because of the high data bandwidth, teletext results are stored in FIFO only. The TVP5147M1 decoder provides fully decoded V-Chip data to the dedicated registers at subaddresses 80 0540h–80 0543h.

Table 2-6. Supported VBI System

VBI SYSTEM	STANDARD	LINE NUMBER	NUMBER OF BYTES
Teletext WST A	SECAM	6-23 (Fields 1 and 2)	38
Teletext WST B	PAL	6-22 (Fields 1 and 2)	43
Teletext NABTS C	NTSC	10-21 (Fields 1 and 2)	34
Teletext NABTS D	NTSC-J	10-21 (Fields 1 and 2)	35
Closed Caption	PAL	22 (Fields 1 and 2)	2
Closed Caption	NTSC	21 (Fields 1 and 2)	2
WSS	PAL	23 (Fields 1 and 2)	14 bits
WSS-CGMS	NTSC	20 (Fields 1 and 2)	20 bits
VITC	PAL	6-22	9
VITC	NTSC	10-20	9
VPS (PDC)	PAL	16	13
V-Chip (decoded)	NTSC	21 (Fields 1 and 2)	2
Gemstar 1x	NTSC		2
Gemstar 2x	NTSC		5 with frame byte
User	Any	Programmable	Programmable

2.7.1 VBI FIFO and Ancillary Data in Video Stream

Sliced VBI data can be output as ancillary data in the video stream in ITU-R BT.656 mode. VBI data is output on the Y[9:2] terminals during the horizontal blanking period. Table 2-7 shows the header format and sequence of the ancillary data inserted into the video stream. This format is also used to store any VBI data into the FIFO. The size of the FIFO is 512 bytes. Therefore, the FIFO can store up to 11 lines of teletext data with the NTSC NABTS standard.

Table 2-7. Ancillary Data Format and Sequence

BYTE NO.	D7 (MSB)	D6	D5	D4	D3	D2	D1	D0 (LSB)	DESCRIPTION	
0	0	0	0	0	0	0	0	0	Ancillary data preamble	
1	1	1	1	1	1	1	1	1		
2	1	1	1	1	1	1	1	1		
3	NEP	EP	0	1	0	DID2	DID1	DID0	Data ID (DID)	
4	NEP	EP	F5	F4	F3	F2	F1	F0	Secondary data ID (SDID)	
5	NEP	EP	N5	N4	N3	N2	N1	N0	Number of 32 bit data (NN)	
6	Video line # [7:0]								Internal data ID0 (IDID0)	
7	0	0	0	Data error	Match #1	Match #2	Video line # [9:8]		Internal data ID1 (IDID1)	
8	1. Data								Data byte	1st word
9	2. Data								Data byte	
10	3. Data								Data byte	
11	4. Data								Data byte	
⋮	⋮								⋮	
	m. Data								Data byte	Nth word
	CS[7:0]								Check sum	
4N+7	0	0	0	0	0	0	0	0	Fill byte	

- EP: Even parity for D0–D5
- NEP: Negated even parity
- DID: 91h: Sliced data of VBI lines of first field
53h: Sliced data of line 24 to end of first field
55h: Sliced data of VBI lines of second field
97h: Sliced data of line 24 to end of second field
- SDID: This field holds the data format taken from the line mode register bits [2:0] of the corresponding line.
- NN: Number of Dwords beginning with byte 8 through 4N+7. This value is the number of Dwords where each Dword is 4 bytes.
- IDID0: Transaction video line number [7:0]
- IDID1: Bit 0/1 = Transaction video line number [9:8]
Bit 2 = Match 2 flag
Bit 3 = Match 1 flag
Bit 4 = 1 if an error was detected in the EDC block.0 if no error was detected.
- CS: Sum of D0–D7 of DID through last data byte
- Fill byte: Fill bytes make a multiple of four bytes from byte 0 to last fill byte. For teletext modes, byte 8 is the sync pattern byte. Byte 9 is the first data byte.

2.7.2 VBI Raw Data Output

The TVP5147M1 decoder can output raw A/D video data at twice the sampling rate for external VBI slicing. This is transmitted as an ancillary data block, although somewhat differently from the way the sliced VBI data is transmitted in the FIFO format as described in Section 2.7.1. The samples are transmitted during the active portion of the line. VBI raw data uses ITU-R BT.656 format having only luma data. The chroma samples are replaced by luma samples. The TVP5147M1 decoder inserts a four-byte preamble 000h 3FFh 3FFh 180h before data start. There are no checksum bytes and fill bytes in this mode.

Table 2-8. VBI Raw Data Output Format

BYTE NO.	D9 (MSB)	D8	D7	D6	D5	D4	D3	D2	D1	D0 (LSB)	DESCRIPTION
0	0	0	0	0	0	0	0	0	0	0	VBI raw data preamble
1	1	1	1	1	1	1	1	1	1	1	
2	1	1	1	1	1	1	1	1	1	1	
3	0	1	1	0	0	0	0	0	0	0	
4	1. Data										2x pixel rate luma data (that is, NTSC 601: n = 1707)
5	2. Data										
⋮	⋮										
n-1	n-5. Data										
n	n-4. Data										

2.8 Reset and Initialization

Reset is initiated at power up or any time terminal 34 (RESETB) is brought low. Table 2-9 describes the status of the TVP5147M1 terminals during and immediately after reset.

Table 2-9. Reset Sequence

SIGNAL NAME	DURING RESET	RESET COMPLETED
Y[9:0], C[9:0]	Input	High impedance
RESETB, PWDN, SDA, SCL, FSS, AVID, GLCO, HS, VS, FID	Input	Input
INTREQ	Input	Output
DATACLK	Output	High impedance

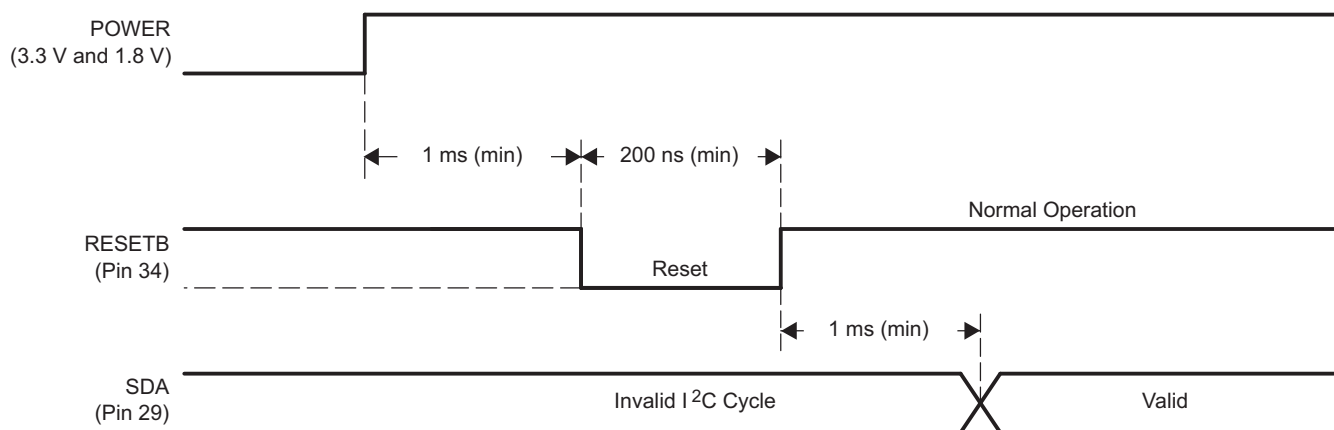

Figure 2-18. Reset Timing

The following register writes must be made before normal operation of the device.

STEP	I ² C SUBADDRESS	I ² C DATA
1	0x03	0x01
2	0x03	0x00

When using any industrial temperature range device (TVP5147M1IPFP and TVP5147M1IPFPQ1), the following I²C register writes must be executed following device power up and RESETB to properly initialize VBUS register 0xA00014. When patch code is being used, these I²C writes must be executed after the patch code has been loaded.

NOTE

The following I²C writes are mandatory for industrial temperature range devices but are optional for commercial temperature range devices (TVP5147M1PFP).

STEP	I ² C SUBADDRESS	I ² C DATA
1	0xE8	0x14
2	0xE9	0x00
3	0xEA	0xA0
4	0xE0	0x14

2.9 Adjusting External Syncs

The proper sequence to program the following external syncs is:

- To set NTSC, PAL-M, NTSC 443, PAL60 (525-line modes):
 - Set the video standard to NTSC (register 02h).
 - Set HSYNC, VSYNC, VBLK, and AVID external syncs (registers 16h through 24h).
- To set PAL, PAL-N, SECAM (625-line modes):
 - Set the video standard to PAL (register 02h).
 - Set HSYNC, VSYNC, VBLK, and AVID external syncs (registers 16h through 24h).
- For autoswitch, set the video standard to autoswitch (register 02h).

2.10 Internal Control Registers

The TVP5147M1 decoder is initialized and controlled by a set of internal registers that define the operating parameters of the entire device. Communication between the external controller and the TVP5147M1 is through a standard I²C host port interface, as described earlier. [Table 2-10](#) shows the summary of these registers. Detailed programming information for each register is described in the following sections. Additional registers are accessible through an indirect procedure involving access to an internal 24-bit address wide VBUS. [Table 2-11](#) shows the summary of the VBUS registers.

NOTE

Do not write to reserved registers. Reserved bits in any defined register must be written with 0s, unless otherwise noted.

Table 2-10. I²C Register Summary⁽¹⁾

REGISTER NAME	I ² C SUBADDRESS	DEFAULT	R/W
Input select	00h	00h	R/W
AFE gain control	01h	0Fh	R/W
Video standard	02h	00h	R/W
Operation mode	03h	00h	R/W
Autoswitch mask	04h	23h	R/W
Color killer	05h	10h	R/W
Luminance processing control 1	06h	00h	R/W
Luminance processing control 2	07h	00h	R/W
Luminance processing control 3	08h	02h	R/W
Luminance brightness	09h	80h	R/W
Luminance contrast	0Ah	80h	R/W
Chrominance saturation	0Bh	80h	R/W
Chroma hue	0Ch	00h	R/W
Chrominance processing control 1	0Dh	00h	R/W
Chrominance processing control 2	0Eh	0Eh	R/W
Reserved	0Fh-15h		
AVID start pixel	16h-17h	055h	R/W
AVID stop pixel	18h-19h	325h	R/W
HSYNC start pixel	1Ah-1Bh	000h	R/W
HSYNC stop pixel	1Ch-1Dh	040h	R/W
VSYNC start line	1Eh-1Fh	004h	R/W
VSYNC stop line	20h-21h	007h	R/W
VBLK start line	22h-23h	001h	R/W
VBLK stop line	24h-25h	015h	R/W
Embedded Sync Offset Control 1	26h	00h	R/W
Embedded Sync Offset Control 2	27h	00h	R/W
Reserved	28h-2Ah		
Overlay delay	2Bh	00h	R/W
Reserved	2Ch		
CTI delay	2Dh	00h	R/W
CTI control	2Eh	00h	R/W
Reserved	2Fh-31h		

(1) R = Read only, W = Write only, R/W = Read and write
Reserved register addresses must not be written to.

Table 2-10. I²C Register Summary⁽¹⁾ (continued)

REGISTER NAME	I ² C SUBADDRESS	DEFAULT	R/W
Sync control	32h	00h	R/W
Output formatter 1	33h	40h	R/W
Output formatter 2	34h	00h	R/W
Output formatter 3	35h	FFh	R/W
Output formatter 4	36h	FFh	R/W
Output formatter 5	37h	FFh	R/W
Output formatter 6	38h	FFh	R/W
Clear lost lock detect	39h	00h	R/W
Status 1	3Ah		R
Status 2	3Bh		R
AGC gain status	3Ch-3Dh		R
Reserved	3Eh		
Video standard status	3Fh		R
GPIO input 1	40h		R
GPIO input 2	41h		R
Reserved	42h-45h		
AFE coarse gain for CH1	46h	20h	R/W
AFE coarse gain for CH2	47h	20h	R/W
AFE coarse gain for CH3	48h	20h	R/W
AFE coarse gain for CH4	49h	20h	R/W
AFE fine gain for Pb	4Ah-4Bh	900h	R/W
AFE fine gain for chroma	4Ch-4Dh	900h	R/W
AFE fine gain for Pr	4Eh-4Fh	900h	R/W
AFE fine gain for CVBS_Luma	50h-51h	900h	R/W
Reserved	52h-56h		
Field ID control	57h	00h	R/W
Reserved	58h-68h		
F-bit and V-bit control 1	69h	00h	R/W
Reserved	6Ah-6Bh		
Back-end AGC control	6Ch	08h	R/W
Reserved	6Dh-6Eh		
AGC decrement speed control	6Fh	04h	R/W
ROM version	70h		R
RAM Version MSB	71h		R
Reserved	72h-73h		
AGC white peak processing	74h	00h	R/W
F and V bit control	75h	12h	R/W
VCR trick mode control	76h	8Ah	R/W
Horizontal shake increment	77h	64h	R/W
AGC increment speed	78h	05h	R/W
AGC increment delay	79h	1Eh	R/W
Reserved	7Ah-7Eh		
Analog output control 1	7Fh	00h	R/W
Chip ID MSB	80h	51h	R
Chip ID LSB	81h	47h	R
RAM Version LSB	82h		R
CPLL speed control	83h	09h	R/W

Table 2-10. I²C Register Summary⁽¹⁾ (continued)

REGISTER NAME	I ² C SUBADDRESS	DEFAULT	R/W
Reserved	84h-96h		
Status request	97h	00h	R/W
Reserved	98h-99h		
Vertical line count	9Ah-9Bh		R
Reserved	9Ch-9Dh		
AGC decrement delay	9Eh	00h	R/W
Reserved	9Fh-B0h		
VDP TTX filter 1 mask 1	B1h	00h	R/W
VDP TTX filter 1 mask 2	B2h	00h	R/W
VDP TTX filter 1 mask 3	B3h	00h	R/W
VDP TTX filter 1 mask 4	B4h	00h	R/W
VDP TTX filter 1 mask 5	B5h	00h	R/W
VDP TTX filter 2 mask 1	B6h	00h	R/W
VDP TTX filter 2 mask 2	B7h	00h	R/W
VDP TTX filter 2 mask 3	B8h	00h	R/W
VDP TTX filter 2 mask 4	B9h	00h	R/W
VDP TTX filter 2 mask 5	BAh	00h	R/W
VDP TTX filter control	BBh	00h	R/W
VDP FIFO word count	BCh		R
VDP FIFO interrupt threshold	BDh	80h	R/W
Reserved	BEh		
VDP FIFO reset	BFh	00h	R/W
VDP FIFO output control	C0h	00h	R/W
VDP line number interrupt	C1h	00h	R/W
VDP pixel alignment	C2h-C3h	01Eh	R/W
Reserved	C4h-D5h		
VDP line start	D6h	06h	R/W
VDP line stop	D7h	1Bh	R/W
VDP global line mode	D8h	FFh	R/W
VDP full field enable	D9h	00h	R/W
VDP full field mode	DAh	FFh	R/W
Reserved	DBh-DFh		
VBUS data access with no VBUS address increment	E0h	00h	R/W
VBUS data access with VBUS address increment	E1h	00h	R/W
FIFO read data	E2h		R
Reserved	E3h-E7h		
VBUS address access	E8h-EAh	00 0000h	R/W
Reserved	EBh-EFh		
Interrupt raw status 0	F0h		R
Interrupt raw status 1	F1h		R
Interrupt status 0	F2h		R
Interrupt status 1	F3h		R
Interrupt mask 0	F4h	00h	R/W
Interrupt mask 1	F5h	00h	R/W
Interrupt clear 0	F6h	00h	R/W
Interrupt clear 1	F7h	00h	R/W
Reserved	F8h-FFh		

Table 2-11. VBUS Register Summary⁽¹⁾

REGISTER NAME	I ² C SUBADDRESS	DEFAULT	R/W
Reserved	00 0000h-80 051Bh		
VDP closed caption data	80 051Ch-80 051Fh		R
VDP WSS/CGMS data	80 0520h-80 0526h		R
Reserved	80 0527h-80 052Bh		
VDP VITC data	80 052Ch-80 0534h		R
Reserved	80 0535h-80 053Fh		
VDP V-Chip data	80 0540h-80 0543h		R
Reserved	80 0544h-80 05FFh		
VDP general line mode and line address	80 0600h-80 0611h	00h, FFh	R/W
Reserved	80 0612h-80 06FFh		
VDP VPS/Gemstar (PDC) data	80 0700h-80 070Ch		R
Reserved	80 070Dh-90 1903h		
VDP FIFO read	90 1904h		R
Reserved	90 1905h-A0 005Dh		
Analog output control 2	A0 05Eh	B2h	R/W
Reserved	A0 005Fh-B0 005Fh		
Interrupt configuration	B0 0060h	00h	R/W
Reserved	B0 0061h-FF FFFFh		

(1) Writing any value to a reserved register may cause erroneous operation of the TVP5147M1 decoder. It is recommended not to access any data to/from reserved registers.

2.11 Register Definitions

Table 2-12. Input Select Register

Subaddress	00h
Default	00h

7	6	5	4	3	2	1	0
Input select [7:0]							

Ten input terminals can be configured to support composite, S-video, and component YPbPr as listed in [Table 2-13](#). User must follow this table properly for S-video and component applications because only the terminal configurations listed in [Table 2-13](#) are supported.

Table 2-13. Analog Channel and Video Mode Selection

MODE	INPUT(S) SELECTED	INPUT SELECT [7:0]									OUTPUT ⁽¹⁾
		7	6	5	4	3	2	1	0	HEX	
CVBS	VI_1_A (default)	0	0	0	0	0	0	0	0	00	N/A
	VI_1_B	0	0	0	0	0	0	0	1	01	VI_1_B
	VI_1_C	0	0	0	0	0	0	1	0	02	VI_1_C
	VI_2_A	0	0	0	0	0	1	0	0	04	VI_2_A
	VI_2_B	0	0	0	0	0	1	0	1	05	VI_2_B
	VI_2_C	0	0	0	0	0	1	1	0	06	VI_2_C
	VI_3_A	0	0	0	0	1	0	0	0	08	VI_3_A
	VI_3_B	0	0	0	0	1	0	0	1	09	VI_3_B
	VI_3_C	0	0	0	0	1	0	1	0	0A	VI_3_C
	VI_4_A	0	0	0	0	1	1	0	0	0C	VI_4_A
S-video	VI_2_A(Y), VI_1_A(C)	0	1	0	0	0	1	0	0	44	N/A
	VI_2_B(Y), VI_1_B(C)	0	1	0	0	0	1	0	1	45	VI_2_B(Y)
	VI_2_C(Y), VI_1_C(C)	0	1	0	0	0	1	1	0	46	VI_2_C(Y)
	VI_2_A(Y), VI_3_A(C)	0	1	0	1	0	1	0	0	54	VI_2_A(Y)
	VI_2_B(Y), VI_3_B(C)	0	1	0	1	0	1	0	1	55	VI_2_B(Y)
	VI_2_C(Y), VI_3_C(C)	0	1	0	1	0	1	1	0	56	VI_2_C(Y)
	VI_4_A(Y), VI_1_A(C)	0	1	0	0	1	1	0	0	4C	N/A
	VI_4_A(Y), VI_1_B(C)	0	1	0	0	1	1	0	1	4D	VI_4_A(Y)
	VI_4_A(Y), VI_1_C(C)	0	1	0	0	1	1	1	0	4E	VI_4_A(Y)
	VI_4_A(Y), VI_3_A(C)	0	1	0	1	1	1	0	0	5C	VI_4_A(Y)
	VI_4_A(Y), VI_3_B(C)	0	1	0	1	1	1	0	1	5D	VI_4_A(Y)
VI_4_A(Y), VI_3_C(C)	0	1	0	1	1	1	1	0	5E	VI_4_A(Y)	
YPbPr	VI_1_A(Pb), VI_2_A(Y), VI_3_A(Pr)	1	0	0	1	0	1	0	0	94	N/A
	VI_1_B(Pb), VI_2_B(Y), VI_3_B(Pr)	1	0	0	1	0	1	0	1	95	VI_2_B(Y)
	VI_1_C(Pb), VI_2_C(Y), VI_3_C(Pr)	1	0	0	1	0	1	1	0	96	VI_2_C(Y)

(1) When VI_1_A is set to output, the total number of inputs is nine. The video output can be either CVBS or luma.

Table 2-14. AFE Gain Control Register

Subaddress	01h						
Default	0Fh						
7	6	5	4	3	2	1	0
Reserved				1	1	AGC chroma	AGC luma

Bit 3: 1b must be written to this bit

Bit 2: 1b must be written to this bit

AGC chroma enable:

Controls automatic gain in the chroma/PbPr channel

0 = Manual (if AGC luma is set to manual, AGC chroma is forced to be in manual)

1 = Enabled auto gain, applied a gain value acquired from the sync channel for S-video and component mode. When AGC luma is set, this state is valid. (default)

AGC luma enable:

Controls automatic gain in the embedded sync channel of CVBS, S-video, component video

0 = Manual gain, AFE coarse and fine gain frozen to the previous gain value set by AGC when this bit is set to 0.

1 = Enabled auto gain applied to only the embedded sync channel (default)

These settings affect only the analog front-end (AFE). The brightness and contrast controls are not affected by these settings.

Table 2-15. Video Standard Select Register

Subaddress	02h						
Default	00h						
7	6	5	4	3	2	1	0
Reserved					Video standard [2:0]		

Video standard [2:0]:

	CVBS and S-Video	Component Video
000	Autoswitch mode (default)	Autoswitch mode (default)
001	(M, J) NTSC	Interlaced 525
010	(B, D, G, H, I, N) PAL	Interlaced 625
011	(M) PAL	Reserved
100	(Combination-N) PAL	Reserved
101	NTSC 4.43	Reserved
110	SECAM	Reserved
111	PAL 60	Reserved

With the autoswitch code running, the user can force the decoder to operate in a particular video standard mode by writing the appropriate value into this register. Changing these bits causes the register settings to be reinitialized.

Table 2-16. Operation Mode Control Register

Subaddress	03h
Default	00h

7	6	5	4	3	2	1	0
Reserved		H-PLL response time		Reserved			Power save

H-PLL response time

00 = Adaptive mode (default).

01 = Reserved mode.

10 = Fast mode.

11 = Normal mode.

When in the Normal mode, the horizontal PLL (H-PLL) response time is set to its slowest setting. This mode improves noise immunity and provides a more stable output line frequency for standard TV signal sources (for example, TV tuners, DVD players, video surveillance cameras, etc.).

When in the Fast mode, the H-PLL response time is set to its fastest setting. This mode enables the H-PLL to respond more quickly to large variations in the horizontal timing (for example, VCR head switching intervals). This mode is recommended for VCRs and also cameras locked to the AC power-line frequency.

When in the Adaptive mode, the H-PLL response time is automatically adjusted based on the measured horizontal phase error. In this mode, the H-PLL response time typically approaches its slowest setting for most standard TV signal sources and approaches its fastest setting for most VCR signal sources.

Power save

0 = Normal operation (default)

1 = Power save mode. Reduces the clock speed of the internal processor and switches off the ADCs. I²C interface is active, and all current operating settings are preserved.

Table 2-17. Autoswitch Mask Register

Subaddress	04h
Default	23h

7	6	5	4	3	2	1	0
Reserved	PAL 60	SECAM	NTSC 4.43	(Nc) PAL	(M) PAL	PAL	(M, J) NTSC

This register limits the video formats between which autoswitch is possible.

PAL 60

0 = Autoswitch does not include PAL 60 (default)

1 = Autoswitch includes PAL 60

SECAM

0 = Autoswitch does not include SECAM

1 = Autoswitch includes SECAM (default)

NTSC 4.43

0 = Autoswitch does not include NTSC 4.43 (default)

1 = Autoswitch includes NTSC 4.43

(Nc) PAL

0 = Autoswitch does not include (Nc) PAL (default)

1 = Autoswitch includes (Nc) PAL

(M) PAL

0 = Autoswitch does not include (M) PAL (default)

1 = Autoswitch includes (M) PAL

PAL

0 = Reserved

1 = Autoswitch includes (B, D, G, H, I, N) PAL (default)

(M, J) NTSC

0 = Reserved

1 = Autoswitch includes (M, J) NTSC (default)

Note: Bits 1 and 0 must always be 11b.

Table 2-18. Color Killer Register

Subaddress	05h						
Default	10h						
7	6	5	4	3	2	1	0
Reserved	Automatic color killer		Color killer threshold [4:0]				

Automatic color killer:

- 00 = Automatic mode (default)
- 01 = Reserved
- 10 = Color killer enabled, the UV terminals are forced to a zero color state
- 11 = Color killer disabled

Color killer threshold [4:0]:

- 11111 = 31 (maximum)
- 10000 = 16 (default)
- 00000 = 0 (minimum)

Table 2-19. Luminance Processing Control 1 Register

Subaddress	06h						
Default	00h						
7	6	5	4	3	2	1	0
Reserved	Pedestal not present	Reserved	VBI raw	Luminance signal delay [3:0]			

Pedestal not present:

- 0 = 7.5 IRE pedestal is present on the analog video input signal (default)
- 1 = Pedestal is not present on the analog video input signal

VBI raw:

- 0 = Disable (default)
- 1 = Enable

During the duration of the vertical blanking as defined by VBLK start and stop registers 22h through 25h, the chroma samples are replaced by luma samples. This feature may be used to support VBI processing performed by an external device during the vertical blanking interval. To use this bit, the output format must be the 10-bit, ITU-R BT.656 mode.

Luminance signal delay [3:0]: Luminance signal delays respect to chroma signal in 1× pixel clock increments.

- 0111 = Reserved
- 0110 = 6 pixel clocks delay
- 0001 = 1 pixel clock delay
- 0000 = 0 pixel clock delay (default)
- 1111 = -1 pixel clock delay
- 1000 = -8 pixel clock delay

Table 2-20. Luminance Processing Control 2 Register

Subaddress	07h
Default	00h

7	6	5	4	3	2	1	0
Luma filter select [1:0]		Reserved		Peaking gain [1:0]		Reserved	

Luma filter selected [1:0]:

00 = Luminance adaptive comb enable (default on CVBS)

01 = Luminance adaptive comb disable (trap filter selected)

10 = Luma comb/trap filter bypassed (default on S-Video, component mode, and SECAM)

11 = Reserved

Peaking gain [1:0]:

00 = 0 (default)

01 = 0.5

10 = 1

11 = 2

Table 2-21. Luminance Processing Control 3 Register

Subaddress	08h
Default	02h

7	6	5	4	3	2	1	0
Reserved						Trap filter select [1:0]	

Trap filter select[1:0]:

Selects one of the four trap filters to produce the luminance signal by removing the chrominance signal from the composite video signal. The stop band of the chroma trap filter is centered at the chroma subcarrier frequency with the stop-band bandwidth controlled by the two control bits.

Trap filter stop band bandwidth (MHz):

Filter select [1:0]	NTSC ITU-R 601	PAL ITU-R 601
00	1.2129	1.2129
01	0.8701	0.8701
10 (default)	0.7183	0.7383
11	0.5010	0.5010

Table 2-22. Luminance Brightness Register

Subaddress	09h
Default	80h

7	6	5	4	3	2	1	0
Brightness [7:0]							

Brightness [7:0]:

This register works for CVBS and S-Video luminance.

0000 0000 = 0 (dark)

1000 0000 = 128 (default)

1111 1111 = 255 (bright)

For composite and S-Video outputs, the output black level relative to the nominal black level (64 out of 1024) as a function of the Brightness[7:0] setting is as follows.

$$\text{Black Level} = \text{nominal_black_level} + (M_B + 1) \times (\text{Brightness}[7:0] - 128)$$

Where M_B is the brightness multiplier setting in the Brightness and Contrast Range Extender register at I²C subaddress 2Fh.

Table 2-23. Luminance Contrast Register

Subaddress	0Ah
Default	80h

7	6	5	4	3	2	1	0
Contrast [7:0]							

Contrast [7:0]:

This register works for CVBS and S-Video luminance. See subaddress 2Fh.

0000 0000 = 0 (minimum contrast)

1000 0000 = 128 (default)

1111 1111 = 255 (maximum contrast)

For composite and S-Video outputs, the total luminance gain relative to the nominal luminance gain as a function of the Contrast [7:0] setting is as follows.

$$\text{Luminance Gain} = (\text{nominal_luminance_gain}) \times [\text{Contrast}[7:0] / 64 / (2^{M_C} + M_C - 1)]$$

Where M_C is the contrast multiplier setting in the Brightness and Contrast Range Extender register at I²C subaddress 2Fh.

Table 2-24. Chrominance Saturation Register

Subaddress	0Bh
Default	80h

7	6	5	4	3	2	1	0
Saturation [7:0]							

Saturation [7:0]:

This register works for CVBS and S-Video chrominance.

0000 0000 = 0 (no color)

1000 0000 = 128 (default)

1111 1111 = 255 (maximum)

For composite and S-Video outputs, the total chrominance gain relative to the nominal chrominance gain as a function of the Saturation [7:0] setting is as follows.

$$\text{Chrominance Gain} = (\text{nominal_chrominance_gain}) \times (\text{Saturation}[7:0] / 128)$$

Table 2-25. Chroma Hue Register

Subaddress	0Ch
Default	00h

7	6	5	4	3	2	1	0
Hue [7:0]							

Hue [7:0]:

Does not apply to a component or SECAM video

0111 1111 = +180 degrees

0000 0000 = 0 degrees (default)

1000 0000 = -180 degrees

Table 2-26. Chrominance Processing Control 1 Register

Subaddress	0Dh
Default	00h

7	6	5	4	3	2	1	0
Reserved			Color PLL reset	Chroma adaptive comb enable	Reserved	Automatic color gain control [1:0]	

Color PLL reset:

0 = Color subcarrier PLL not reset (default)

1 = Color subcarrier PLL reset

Chrominance adaptive comb enable:

This bit is effective on composite video only.

0 = Enable (default)

1 = Disable

Automatic color gain control (ACGC) [1:0]:

00 = ACGC enabled (default)

01 = Reserved

10 = ACGC disabled, ACGC set to the nominal value

11 = ACGC frozen to the previously set value

Table 2-27. Chrominance Processing Control 2 Register

Subaddress	0Eh
Default	0Eh

7	6	5	4	3	2	1	0
Reserved			PAL compensation	WCF	Chrominance filter select [1:0]		

PAL compensation:

0 = Disabled

1 = Enabled (default)

Wideband chroma LPF filter (WCF):

0 = Disabled

1 = Enabled (default)

Chrominance filter select [1:0]:

00 = Disabled

01 = Notch 1

10 = Notch 2 (default)

11 = Notch 3

See [Figure 2-6](#) and [Figure 2-7](#) for characteristics.

Table 2-28. R/Pr Gain (Color Saturation) Register

Subaddress	10h
Default	80h

7	6	5	4	3	2	1	0
R/Pr gain [7:0]							

R/Pr component gain (color saturation):

0000 0000 = minimum

1000 0000 = default

1111 1111 = maximum

For component video, the total R/Pr gain relative to the nominal R/Pr gain as a function of the R/Pr gain [7:0] setting is as follows:

$$\text{R/Pr Gain} = (\text{nominal_chrominance_gain}) \times (\text{R/Pr gain [7:0]} / 128)$$

Table 2-29. G/Y Gain (Contrast) Register

Subaddress	11h
Default	80h

7	6	5	4	3	2	1	0
G/Y gain [7:0]							

G/Y component gain (contrast):

0000 0000 = minimum

1000 0000 = default

1111 1111 = maximum

For component video outputs, the total luma gain relative to the nominal luma gain as a function of the G/Y gain[7:0] is as follows:

$$\text{Luma gain} = (\text{nominal_luminance_gain}) \times (\text{G/Y gain [7:0]} / 128)$$

Table 2-30. B/Pb Gain (Color Saturation) Register

Subaddress	12h
Default	80h

7	6	5	4	3	2	1	0
B/Pb gain [7:0]							

B/Pb component gain (color saturation):

0000 0000 = minimum

1000 0000 = default

1111 1111 = maximum

For component video, the total B/Pb gain relative to the nominal B/Pb gain as a function of the B/Pb gain [7:0] setting is as follows:

$$\text{B/Pb Gain} = (\text{nominal_chrominance_gain}) \times (\text{B/Pb gain [7:0]} / 128)$$

Table 2-31. G/Y Offset Register

Subaddress	14h
Default	80h

7	6	5	4	3	2	1	0
G/Y offset [7:0]							

G/Y component offset (brightness):

0000 0000 = minimum

1000 0000 = default

1111 1111 = maximum

For component video, the output black level relative to the nominal black level (64 out of 1024) as a function of G/Y offset [7:0] is as follows:

$$\text{Black Level} = \text{nominal_black_level} + (\text{G/Y offset [7:0]} - 128)$$

Table 2-32. AVID Start Pixel Register

Subaddress	16h–17h							
Default	55h							
Subaddress	7	6	5	4	3	2	1	0
16h	AVID start [7:0]							
17h	Reserved			AVID active	Reserved		AVID start [9:8]	

AVID active:

0 = AVID out active in VBLK (default)

1 = AVID out inactive in VBLK

AVID start [9:0]:

AVID start pixel number, this is an absolute pixel location from HSYNC start pixel 0.

NTSC 601 default: is 85 (55h)

PAL 601 default: is 95 (5Fh)

The TVP5147M1 decoder updates the AVID start only when the AVID start MSB byte is written to. If the user changes these registers, then the TVP5147M1 decoder retains values in different modes until this device resets. The AVID start pixel register also controls the position of the SAV code.

Table 2-33. AVID Stop Pixel Register

Subaddress	18h–19h							
Default	325h							
Subaddress	7	6	5	4	3	2	1	0
18h	AVID stop [7:0]							
19h	Reserved						AVID stop [9:8]	

AVID stop [9:0]:

AVID stop pixel number. The number of pixels of active video must be an even number. This is an absolute pixel location from HSYNC start pixel 0.

For NTSC 601, default is 805 (325h)

For PAL 601, default is 815 (32Fh)

The TVP5147M1 decoder updates the AVID stop only when the AVID stop MSB byte is written to. If the user changes these registers, then the TVP5147M1 decoder retains values in different modes until this device resets. The AVID start pixel register also controls the position of the EAV code.

Table 2-34. HSYNC Start Pixel Register

Subaddress	1Ah–1Bh							
Default	000h							
Subaddress	7	6	5	4	3	2	1	0
1Ah	HSYNC start [7:0]							
1Bh	Reserved						HSYNC start [9:8]	

HSYNC start pixel [9:0]:

This is an absolute pixel location from HSYNC start pixel 0.

The TVP5147M1 decoder updates the HSYNC start only when the HSYNC start MSB is written to. If the user changes these registers, then the TVP5147M1 decoder retains values in different modes until this device resets.

Table 2-35. HSYNC Stop Pixel Register

Subaddress	1Ch–1Dh							
Default	040h							
Subaddress	7	6	5	4	3	2	1	0
1Ch	HSYNC stop [7:0]							
1Dh	Reserved						HSYNC stop [9:8]	

HSYNC stop [9:0]:

This is an absolute pixel location from HSYNC start pixel 0.

The TVP5147M1 decoder updates the HSYNC stop only when the HSYNC stop MSB is written to. If the user changes these registers, then the TVP5147M1 decoder retains values in different modes until this device resets.

Table 2-36. VSYNC Start Line Register

Subaddress	1Eh–1Fh							
Default	004h							
Subaddress	7	6	5	4	3	2	1	0
1Eh	VSYNC start [7:0]							
1Fh	Reserved						VSYNC start [9:8]	

VSYNC start [9:0]:

This is an absolute line number.

The TVP5147M1 decoder updates the VSYNC start only when the VSYNC start MSB is written to. If the user changes these registers, then the TVP5147M1 decoder retains values in different modes until this decoder resets.

NTSC: default 004h

PAL: default 001h

Table 2-37. VSYNC Stop Line Register

Subaddress	20h–21h							
Default	007h							
Subaddress	7	6	5	4	3	2	1	0
20h	VSYNC stop [7:0]							
21h	Reserved						VSYNC stop [9:8]	

VSYNC stop [9:0]:

This is an absolute line number.

The TVP5147M1 decoder updates the VSYNC stop only when the VSYNC stop MSB is written to. If the user changes these registers, the TVP5147M1 decoder retains values in different modes until this decoder resets.

NTSC: default 007h

PAL: default 004h

Table 2-38. VBLK Start Line Register

Subaddress	22h–23h							
Default	001h							
Subaddress	7	6	5	4	3	2	1	0
22h	VBLK start [7:0]							
23h	Reserved						VBLK start [9:8]	

VBLK start [9:0]:

This is an absolute line number.

The TVP5147M1 decoder updates the VBLK start line only when the VBLK start MSB is written to. If the user changes these registers, the TVP5147M1 decoder retains values in different modes until this resets (see [Table 2-32](#))

NTSC: default 001h

PAL: default 623 (26Fh)

Table 2-39. VBLK Stop Line Register

Subaddress	24h–25h							
Default	015h							
Subaddress	7	6	5	4	3	2	1	0
24h	VBLK stop [7:0]							
25h	Reserved						VBLK stop [9:8]	

VBLK stop [9:0]:

This is an absolute line number.

The TVP5147M1 decoder updates the VBLK stop only when the VBLK stop MSB is written to. If the user changes these registers, then the TVP5147M1 decoder retains values in different modes until this device resets (see [Table 2-32](#)).

NTSC: default 21 (015h)

PAL: default 23 (017h)

Table 2-40. Embedded Sync Offset Control 1 Register

Subaddress	26h							
Default	00h							
	7	6	5	4	3	2	1	0
Offset [7:0]								

This register allows the line position of the embedded F bit and V bit signals to be offset from the 656 standard positions. This register is only applicable to input video signals with standard number of lines.

0111 1111 = 127 lines
 ⋮
 0000 0001 = 1 line
 0000 0000 = 0 line
 1111 1111 = –1 line
 ⋮
 1000 0000 = –128 lines

Table 2-41. Embedded Sync Offset Control 2 Register

Subaddress	27h							
Default	00h							
	7	6	5	4	3	2	1	0
Offset [7:0]								

This register allows the line relationship between the embedded F bit and V bit signals to be offset from the 656 standard positions, and moves F relative to V. This register is only applicable to input video signals with standard number of lines.

0111 1111 = 127 lines
 ⋮
 0000 0001 = 1 line
 0000 0000 = 0 line
 1111 1111 = –1 line
 ⋮
 1000 0000 = –128 lines

Table 2-42. CTI Delay Register

Subaddress	2Dh						
Default	00h						
7	6	5	4	3	2	1	0
Reserved					CTI delay [2:0]		

CTI delay [2:0]:

Sets the delay of the Y channel with respect to Cb/Cr in the CTI block

- 011 = 3-pixel delay
- 001 = 1-pixel delay
- 000 = 0 delay (default)
- 111 = -1-pixel delay
- 100 = -4-pixel delay

Table 2-43. CTI Control Register

Subaddress	2Eh						
Default	00h						
7	6	5	4	3	2	1	0
CTI coring [3:0]				CTI gain [3:0]			

CTI coring [3:0]:

4-bit CTI coring limit control values, unsigned, linear control range from 0 to ± 60 , step size = 4

- 1111 = ± 60
- ⋮

- 0001 = ± 4
- 0000 = 0 (default)

CTI gain [3:0]:

4-bit CTI gain control values, unsigned, linear control range from 0 to 15/16, step size = 1/16

- 1111 = 15/16
- ⋮

- 0001 = 1/16
- 0000 = 0 (default)

Table 2-44. Brightness and Contrast Range Extender Register

Subaddress	2Fh						
Default	00h						
7	6	5	4	3	2	1	0
Reserved			Contrast multiplier	Brightness multiplier [3:0]			

Contrast multiplier (M_C):

Increases the contrast control range for composite and S-Video modes.

0 = 2x contrast control range (default), Gain = $n/64 - 1$ where n is the contrast control and $64 \leq n \leq 255$

1 = Normal contrast control range, Gain = $n/128$ where n is the contrast control and $0 \leq n \leq 255$

Brightness multiplier [3:0] (M_B):

Increases the brightness control range for composite and S-Video modes from 1x to 16x.

- 0h = 1x
- 1h = 2x
- 3h = 4x
- 7h = 8x
- Fh = 16x

Note: In general, the brightness multiplier should be set to 0h for 10-bit outputs and 3h for 8-bit outputs

Table 2-45. Sync Control Register

Subaddress	32h						
Default	00h						
7	6	5	4	3	2	1	0
Reserved			Polarity FID	Polarity VS	Polarity HS	VS/VBLK	HS/CS

Polarity FID:

- Determines polarity of FID terminal
- 0 = First field high, second field low (default)
- 1 = First field low, second field high

Polarity VS:

- Determines polarity of VS terminal
- 0 = Active low (default)
- 1 = Active high

Polarity HS:

- Determines polarity of HS terminal
- 0 = Active low (default)
- 1 = Active high

VS/VBLK:

- 0 = VS terminal outputs vertical sync (default)
- 1 = VS terminal outputs vertical blank

HS/CS:

- 0 = HS terminal outputs horizontal sync (default)
- 1 = HS terminal outputs composite sync

Table 2-46. Output Formatter Control 1 Register

Subaddress	33h						
Default	40h						
7	6	5	4	3	2	1	0
Reserved	YCbCr code range	CbCr code	Reserved		Output format [2:0]		

YCbCr output code range:

- 0 = ITU-R BT.601 coding range (Y ranges from 64 to 940. Cb and Cr range from 64 to 960.)
- 1 = Extended coding range (Y, Cb, and Cr range from 4 to 1016) (default)

CbCr code format:

- 0 = Offset binary code (2s complement + 512) (default)
- 1 = Straight binary code (2s complement)

Output format [2:0]:

- 000 = 10-bit 4:2:2 (pixel x 2 rate) with embedded syncs (ITU-R BT.656) (default)
- 001 = 20-bit 4:2:2 (pixel rate) with separate syncs
- 010 = Reserved
- 011 = 10-bit 4:2:2 with separate syncs
- 100–111 = Reserved

Note: 10-bit mode is also used for the raw VBI output mode when bit 4 (VBI raw) in the luminance processing control 1 register at subaddress 06h is set (see [Table 2-19](#)).

Table 2-47. Output Formatter Control 2 Register

Subaddress	34h
Default	00h

7	6	5	4	3	2	1	0
Reserved			Data enable	Black Screen [1:0]		CLK polarity	Clock enable

Data enable:

Y[9:0] and C[9:0] output enable

0 = Y[9:0] and C[9:0] high-impedance (default)

1 = Y [9:0] and C[9:0] active

Black Screen [1:0]:

00 = Normal operation (default)

01 = Black screen out when TVP5147M1 detects lost lock (using with tuner input but not with VCR)

10 = Black screen out

11 = Black screen out

CLK polarity:

0 = Data clocked out on the falling edge of DATACLK (default)

1 = Data clocked out on the rising edge of DATACLK

Clock enable:

0 = DATACLK outputs are high-impedance (default)

1 = DATACLK outputs are enabled

Table 2-48. Output Formatter Control 3 Register

Subaddress	35h
Default	FFh

7	6	5	4	3	2	1	0
GPIO [1:0]		AVID [1:0]		GLCO [1:0]		FID [1:0]	

GPIO [1:0]:

FSS terminal function select

00 = GPIO is logic 0 output

01 = GPIO is logic 1 output

10 = Reserved

11 = GPIO is logic input (default)

AVID [1:0]:

AVID terminal function select

00 = AVID is logic 0 output

01 = AVID is logic 1 output

10 = AVID is active video indicator output

11 = AVID is logic input (default)

GLCO [1:0]:

GLCO terminal function select

00 = GLCO is logic 0 output

01 = GLCO is logic 1 output

10 = GLCO is genlock output

11 = GLCO is logic input (default)

FID [1:0]:

FID terminal function select

00 = FID is logic 0 output

01 = FID is logic 1 output

10 = FID is FID output

11 = FID is logic input (default)

Table 2-49. Output Formatter Control 4 Register

Subaddress	36h
Default	FFh

7	6	5	4	3	2	1	0
VS/VBLK [1:0]		HS/CS [1:0]		C_1 [1:0]		C_0 [1:0]	

VS/VBLK [1:0]:

VS terminal function select

00 = VS is logic 0 output

01 = VS is logic 1 output

 10 = VS/VBLK is vertical sync or vertical blank output corresponding to bit 1 (VS/VBLK) in the sync control register at subaddress 32h (see [Table 2-45](#))

11 = VS is logic input (default)

HS/CS [1:0]:

HS terminal function select

00 = HS is logic 0 output

01 = HS is logic 1 output

 10 = HS/CS is horizontal sync or composite sync output corresponding to bit 0 (HS/CS) in the sync control register at subaddress 32h (see [Table 2-45](#))

11 = HS is logic input (default)

C_1 [1:0]:

C_1 terminal function select

00 = C_1 is logic 0 output

01 = C_1 is logic 1 output

10 = Reserved

11 = C_1 is logic input (default)

C_0 [1:0]:

C_0 terminal function select

00 = C_0 is logic 0 output

01 = C_0 is logic 1 output

10 = Reserved

11 = C_0 is logic input (default)

Note: C_x functions are available only in the 10-bit output mode.

Table 2-50. Output Formatter Control 5 Register

Subaddress	37h
Default	FFh

7	6	5	4	3	2	1	0
C_5 [1:0]		C_4 [1:0]		C_3 [1:0]		C_2 [1:0]	

C_5 [1:0]:

C_5 terminal function select

00 = C_5 is logic 0 output

01 = C_5 is logic 1 output

10 = Reserved

11 = C_5 is logic input (default)

C_4 [1:0]:

C_4 terminal function select

00 = C_4 is logic 0 output

01 = C_4 is logic 1 output

10 = Reserved

11 = C_4 is logic input (default)

C_3 [1:0]:

C_3 terminal function select

00 = C_3 is logic 0 output

01 = C_3 is logic 1 output

10 = Reserved

11 = C_3 is logic input (default)

C_2 [1:0]:

C_2 terminal function select

00 = C_2 is logic 0 output

01 = C_2 is logic 1 output

10 = Reserved

11 = C_2 is logic input (default)

Note: C_x functions are available only in the 10-bit output mode.

Table 2-51. Output Formatter Control 6 Register

Subaddress	38h
Default	FFh

7	6	5	4	3	2	1	0
C_9 [1:0]		C_8 [1:0]		C_7 [1:0]		C_6 [1:0]	

C_9 [1:0]:

C_9 terminal function select

00 = C_9 is logic 0 output

01 = C_9 is logic 1 output

10 = Reserved

11 = C_9 is logic input (default)

C_8 [1:0]:

C_8 terminal function select

00 = C_8 is logic 0 output

01 = C_8 is logic 1 output

10 = Reserved

11 = C_8 is logic input (default)

C_7 [1:0]:

C_7 terminal function select

00 = C_7 is logic 0 output

01 = C_7 is logic 1 output

10 = Reserved

11 = C_7 is logic input (default)

C_6 [1:0]:

C_6 terminal function select

00 = C_6 is logic 0 output

01 = C_6 is logic 1 output

10 = Reserved

11 = C_6 is logic input (default)

Table 2-52. Clear Lost Lock Detect Register

Subaddress	39h
Default	00h

7	6	5	4	3	2	1	0
Reserved							Clear lost lock detect

Clear lost lock detect:

Clear bit 4 (lost lock detect) in the status 1 register at subaddress 3Ah (see [Table 2-53](#))

0 = No effect (default)

1 = Clears bit 4 in the status 1 register

Table 2-53. Status 1 Register

Subaddress	3Ah						
	Read only						
7	6	5	4	3	2	1	0
Peak white detect status	Line-alternating status	Field rate status	Lost lock detect	Color subcarrier lock status	Vertical sync lock status	Horizontal sync lock status	TV/VCR status

Peak white detect status:

- 0 = Peak white is not detected
- 1 = Peak white is detected

Line-alternating status:

- 0 = Non line-alternating
- 1 = Line-alternating

Field rate status:

- 0 = 60 Hz
- 1 = 50 Hz

Lost lock detect:

- 0 = No lost lock since this bit was last cleared
- 1 = Lost lock since this bit was last cleared

Color subcarrier lock status:

- 0 = Color subcarrier is not locked
- 1 = Color subcarrier is locked

Vertical sync lock status:

- 0 = Vertical sync is not locked
- 1 = Vertical sync is locked

Horizontal sync lock status:

- 0 = Horizontal sync is not locked
- 1 = Horizontal sync is locked

TV/VCR status:

- 0 = TV
- 1 = VCR

Table 2-54. Status 2 Register

Subaddress	3Bh						
	Read only						
7	6	5	4	3	2	1	0
Signal present	Weak signal detection	PAL switch polarity	Field sequence status	Color killed	Macrovision detection [2:0]		

Signal present detection:

- 0 = Signal not present
- 1 = Signal present

Weak signal detection:

- 0 = No weak signal
- 1 = Weak signal mode

PAL switch polarity of first line of odd field:

- 0 = PAL switch is 0b
- 1 = PAL switch is 1b

Field sequence status:

- 0 = Even field
- 1 = Odd field

Color killed:

- 0 = Color killer not active
- 1 = Color killer activated

Macrovision detection [2:0]:

- 000 = No copy protection
- 001 = AGC pulses/pseudo syncs present (Type 1)
- 010 = 2-line colorstripe only present
- 011 = AGC pulses/pseudo syncs and 2-line colorstripe present (Type 2)
- 100 = Reserved
- 101 = Reserved
- 110 = 4-line colorstripe only present
- 111 = AGC pulses/pseudo syncs and 4-line colorstripe present (Type 3)

Table 2-55. AGC Gain Status Register

Subaddress	3Ch–3Dh							
	Read only							
Subaddress	7	6	5	4	3	2	1	0
3Ch	Fine Gain [7:0]							
3Dh	Coarse Gain [3:0]			Fine Gain [11:8]				

Fine gain [11:0]:

This register provides the fine gain value of sync channel.

- 1111 1111 1111 = 1.9995
- 1000 0000 0000 = 1
- 0010 0000 0000 = 0.5

Coarse gain [3:0]:

This register provides the coarse gain value of sync channel.

- 1111 = 2
- 0101 = 1
- 0000 = 0.5

The AGC gain status register is updated automatically by the TVP5147M1 decoder when AGC is on. In manual gain control mode, these register values are not updated by the TVP5147M1 decoder.

Table 2-56. Video Standard Status Register

Subaddress	3Fh						
	Read only						
7	6	5	4	3	2	1	0
Autoswitch	Reserved				Video standard [2:0]		

Autoswitch mode

0 = Single standard set

1 = Autoswitch mode enabled

Video standard [2:0]:

	CVBS and S-Video	Component Video
000	Reserved	Reserved
001	(M, J) NTSC	Component 525
010	(B, D, G, H, I, N) PAL	Component 625
011	(M) PAL	Reserved
100	(Combination-N) PAL	Reserved
101	NTSC 4.43	Reserved
110	SECAM	Reserved
111	PAL 60	Reserved

This register contains information about the detected video standard that the device is currently operating. When autoswitch code is running, this register must be tested to determine which video standard has been detected.

Table 2-57. GPIO Input 1 Register

Subaddress	40h						
	Read only						
7	6	5	4	3	2	1	0
C_7	C_6	C_5	C_4	C_3	C_2	C_1	C_0

C_x input status:

0 = Input is low

1 = Input is high

These status bits are valid only when terminals are used as inputs and are updated at every line.

Table 2-58. GPIO Input 2 Register

Subaddress	41h						
	Read only						
7	6	5	4	3	2	1	0
GPIO	AVID	GLCO	VS	HS	FID	C_9	C_8

GPIO input terminal status:

0 = Input is a low

1 = Input is a high

AVID input terminal status:

0 = Input is a low

1 = Input is a high

GLCO input terminal status:

0 = Input is a low

1 = Input is a high

VS input terminal status:

0 = Input is a low

1 = Input is a high

HS input status:

0 = Input is a low

1 = Input is a high

FID input status:

0 = Input is a low

1 = Input is a high

C_x input status:

0 = Input is a low

1 = Input is a high

These status bits are valid only when terminals are used as inputs and are updated at every line.

Table 2-59. AFE Coarse Gain for CH 1 Register

Subaddress	46h						
Default	20h						
7	6	5	4	3	2	1	0
CGAIN 1 [3:0]				Reserved			

CGAIN 1 [3:0]:

Coarse Gain = $0.5 + (\text{CGAIN } 1)/10$ where $0 \leq \text{CGAIN } 1 \leq 15$

This register works only in manual gain control mode. When AGC is active, writing to any value is ignored.

1111 = 2

1110 = 1.9

1101 = 1.8

1100 = 1.7

1011 = 1.6

1010 = 1.5

1001 = 1.4

1000 = 1.3

0111 = 1.2

0110 = 1.1

0101 = 1

0100 = 0.9

0011 = 0.8

0010 = 0.7(default)

0001 = 0.6

0000 = 0.5

Table 2-60. AFE Coarse Gain for CH 2 Register

Subaddress	47h
Default	20h

7	6	5	4	3	2	1	0
CGAIN 2 [3:0]				Reserved			

CGAIN 2 [3:0]:

Coarse Gain = $0.5 + (\text{CGAIN } 2)/10$ where $0 \leq \text{CGAIN } 2 \leq 15$.

This register works only in manual gain control mode. When AGC is active, writing to any value is ignored.

1111 = 2
 1110 = 1.9
 1101 = 1.8
 1100 = 1.7
 1011 = 1.6
 1010 = 1.5
 1001 = 1.4
 1000 = 1.3
 0111 = 1.2
 0110 = 1.1
 0101 = 1
 0100 = 0.9
 0011 = 0.8
 0010 = 0.7(default)
 0001 = 0.6
 0000 = 0.5

Table 2-61. AFE Coarse Gain for CH 3 Register

Subaddress	48h
Default	20h

7	6	5	4	3	2	1	0
CGAIN 3 [3:0]				Reserved			

CGAIN 3 [3:0]:

Coarse Gain = $0.5 + (\text{CGAIN } 3)/10$ where $0 \leq \text{CGAIN } 3 \leq 15$.

This register works only in manual gain control mode. When AGC is active, writing to any value is ignored.

1111 = 2
 1110 = 1.9
 1101 = 1.8
 1100 = 1.7
 1011 = 1.6
 1010 = 1.5
 1001 = 1.4
 1000 = 1.3
 0111 = 1.2
 0110 = 1.1
 0101 = 1
 0100 = 0.9
 0011 = 0.8
 0010 = 0.7(default)
 0001 = 0.6
 0000 = 0.5

Table 2-62. AFE Coarse Gain for CH 4 Register

Subaddress	49h
Default	20h

7	6	5	4	3	2	1	0
CGAIN 4 [3:0]				Reserved			

CGAIN 4 [3:0]:

Coarse Gain = $0.5 + (\text{CGAIN } 4)/10$ where $0 \leq \text{CGAIN } 4 \leq 15$.

This register works only in manual gain control mode. When AGC is active, writing to any value is ignored.

1111 = 2

1110 = 1.9

1101 = 1.8

1100 = 1.7

1011 = 1.6

1010 = 1.5

1001 = 1.4

1000 = 1.3

0111 = 1.2

0110 = 1.1

0101 = 1

0100 = 0.9

0011 = 0.8

0010 = 0.7(default)

0001 = 0.6

0000 = 0.5

Table 2-63. AFE Fine Gain for Pb Register

Subaddress	4Ah–4Bh
Default	900h

Subaddress	7	6	5	4	3	2	1	0
4Ah	FGAIN 1 [7:0]							
4Bh	Reserved				FGAIN 1 [11:8]			

FGAIN 1 [11:0]:

This fine gain applies to component Pb.

Fine Gain = $(1/2048) \times \text{FGAIN } 1$, where $0 \leq \text{FGAIN } 1 \leq 4095$

This register is only updated when the MSB (register 4Bh) is written to.

This register works only in manual gain control mode. When AGC is active, writing to any value is ignored.

1111 1111 1111 = 1.9995

1100 0000 0000 = 1.5

1001 0000 0000 = 1.125 (default)

1000 0000 0000 = 1

0100 0000 0000 = 0.5

0011 1111 1111 to 0000 0000 0000 = Reserved

Table 2-64. AFE Fine Gain for Y_Chroma Register

Subaddress	4Ch–4Dh							
Default	900h							
Subaddress	7	6	5	4	3	2	1	0
4Ch	FGAIN 2 [7:0]							
4Dh	Reserved				FGAIN 2 [11:8]			

FGAIN 2 [11:0]:

This gain applies to component Y channel or S-video chroma (see AFE fine gain for Pb register, [Table 2-63](#)).

This register works only in manual gain control mode. When AGC is active, writing to any value is ignored.

1111 1111 1111 = 1.9995

1100 0000 0000 = 1.5

1001 0000 0000 = 1.125 (default)

1000 0000 0000 = 1

0100 0000 0000 = 0.5

0011 1111 1111 to 0000 0000 0000 = Reserved

Table 2-65. AFE Fine Gain for Pr Register

Subaddress	4Eh–4Fh							
Default	900h							
Subaddress	7	6	5	4	3	2	1	0
4Eh	FGAIN 3 [7:0]							
4Fh	Reserved				FGAIN 3 [11:8]			

FGAIN 3 [11:0]:

This fine gain applies to component Pr (see AFE fine gain for Pb register, [Table 2-63](#)).

This register works only in manual gain control mode. When AGC is active, writing to any value is ignored.

1111 1111 1111 = 1.9995

1100 0000 0000 = 1.5

1001 0000 0000 = 1.125 (default)

1000 0000 0000 = 1

0100 0000 0000 = 0.5

0011 1111 1111 to 0000 0000 0000 = Reserved

Table 2-66. AFE Fine Gain for CVBS_Luma Register

Subaddress	50h–51h							
Default	900h							
Subaddress	7	6	5	4	3	2	1	0
50h	FGAIN 4 [7:0]							
51h	Reserved				FGAIN 4 [11:8]			

FGAIN 4 [11:0]:

This fine gain applies to CVBS or S-video luma (see AFE fine gain for Pb register, [Table 2-63](#)).

This register works only in manual gain control mode. When AGC is active, writing to any value is ignored.

1111 1111 1111 = 1.9995

1100 0000 0000 = 1.5

1001 0000 0000 = 1.125 (default)

1000 0000 0000 = 1

0100 0000 0000 = 0.5

0011 1111 1111 to 0000 0000 0000 = Reserved

Table 2-67. Field ID Control Register

Subaddress	57h
Default	00h

7	6	5	4	3	2	1	0
Reserved						656 version	FID control

656 version:

0 = ITU-R BT.656-4 (default)

1 = ITU-R BT.656-3

FID control:

0 = 0→1 adapts to field 1, 1→0 adapts to field 1 + field 2 (default)

1 = 0→1 adapts to field 2, 1→0 adapts to field 1 + field 2 (for TVP5147M1 EVM)

Table 2-68. F-Bit and V-Bit Decode Control 1 Register

Subaddress	69h
Default	00h

7	6	5	4	3	2	1	0
Reserved			VPLL	Adaptive	Reserved	F-bit Mode [1:0]	

VPLL:

VPLL time constant control

0 = VPLL adapts the time constant to the input signal (default)

1 = VPLL time constants are fixed

Adaptive:

0 = Enable F-bit and V-bit adaptation to detected lines per frame (default)

1 = Disable F-bit and V-bit adaptation to detected lines per frame

F-bit mode:

00 = Auto mode. If lines per frame is standard decode F and V bits as per 656 standard from line count else decode F bit from vsync input and set V bit = 0b (default)

01 = Decode F and V bits from input syncs

10 = Reserved

11 = Always decode F and V bits from line count

This register is used in conjunction with register 75h as indicated below:

REGISTER 69H		REGISTER 75H		MODE	STANDARD LPF		NONSTANDARD LPF	
BIT 1	BIT 0	BIT 3	BIT 2		F	V	F	V
0	0	0	0	Reserved	Reserved	Reserved	Reserved	Reserved
0	0	0	1	TVP5160	656	656	Toggle	Switch9
0	0	1	0	TVP5160	656	656	Pulse	0
0	0	1	1	Reserved	Reserved	Reserved	Reserved	Reserved
0	1	0	0	Reserved	Reserved	Reserved	Reserved	Reserved
0	1	0	1		656	656	Toggle	Switch9
0	1	1	0		656	656	Pulse	0
0	1	1	1	Reserved	Reserved	Reserved	Reserved	Reserved
1	0	0	0	Reserved	Reserved	Reserved	Reserved	Reserved
1	0	0	1	Reserved	Reserved	Reserved	Reserved	Reserved
1	0	1	0	Reserved	Reserved	Reserved	Reserved	Reserved
1	0	1	1	Reserved	Reserved	Reserved	Reserved	Reserved
1	1	0	0	TVP5146	656	656	Even = 1 Odd = toggle	Switch
1	1	0	1	TVP5146	656	656	Toggle	Switch
1	1	1	0	TVP5146	656	656	Pulse	Switch
1	1	1	1	Reserved	Reserved	Reserved	Reserved	Reserved

656 = ITU-R BT.656 standard

Toggle = Toggles from field to field

Pulse = Pulses low for 1 line prior to field transition

Switch = V bit switches high before the F-bit transition and low after the F-bit transition

Switch9 = V bit switches high 1 line prior to the F-bit transition, then low after nine lines

Reserved = Not used

Table 2-69. Back-End AGC Control Register

Subaddress	6Ch
Default	08h

7	6	5	4	3	2	1	0
Reserved				1	Peak	Color	Sync

This register disables the back-end AGC when the front-end AGC uses specific amplitude references (sync-height, color burst, or composite peak) to decrement the front-end gain. For example, writing 0x09 to this register disables the back-end AGC whenever the front-end AGC uses the sync-height to decrement the front-end gain.

Peak:

Disables back-end AGC when the front-end AGC uses the composite peak as an amplitude reference.

0 = Disabled (default)

1 = Enabled

Color:

Disables back-end AGC when the front-end AGC uses the color burst as an amplitude reference.

0 = Disabled (default)

1 = Enabled

Sync:

Disables back-end AGC when the front-end AGC uses the sync height as an amplitude reference.

0 = Disabled (default)

1 = Enabled

Table 2-70. AGC Decrement Speed Register

Subaddress	6Fh
Default	04h

7	6	5	4	3	2	1	0
Reserved				AGC decrement speed [2:0]			

AGC decrement speed:

Adjusts gain decrement speed. Only used for composite/luma peaks.

111 = 7 (slowest)

110 = 6 (default)

⋮

000 = 0 (fastest)

Table 2-71. ROM Version Register

Subaddress	70h
	Read only

7	6	5	4	3	2	1	0
ROM version [7:0]							

ROM Version [7:0]:

ROM revision number

Table 2-72. RAM Version MSB Register

Subaddress	71h
	Read only

7	6	5	4	3	2	1	0
RAM version MSB [7:0]							

RAM version MSB [7:0]:

This register identifies the MSB of the RAM code revision number.

Table 2-73. AGC White Peak Processing Register

Subaddress	74h
Default	00h

7	6	5	4	3	2	1	0
Luma peak A	Reserved	Color burst A	Sync height A	Luma peak B	Composite peak	Color burst B	Sync height B

Luma peak A:

Use of the luma peak as a video amplitude reference for the back-end feed-forward type AGC algorithm

- 0 = Enabled (default)
- 1 = Disabled

Color burst A:

Use of the color burst amplitude as a video amplitude reference for the back-end

Note: Not available for SECAM, component, and B/W video sources.

- 0 = Enabled (default)
- 1 = Disabled

Sync height A:

Use of the sync height as a video amplitude reference for the back-end feed-forward type AGC algorithm

- 0 = Enabled (default)
- 1 = Disabled

Luma peak B:

Use of the luma peak as a video amplitude reference for front-end feedback type AGC algorithm

- 0 = Enabled (default)
- 1 = Disabled

Composite peak:

Use of the composite peak as a video amplitude reference for front-end feedback type AGC algorithm

Note: Required for CVBS video sources

- 0 = Enabled (default)
- 1 = Disabled

Color burst B:

Use of the color burst amplitude as a video amplitude reference for front-end feedback type AGC algorithm

Note: Not available for SECAM, component, and B/W video sources

- 0 = Enabled (default)
- 1 = Disabled

Sync height B:

Use of the sync-height as a video amplitude reference for front-end feedback type AGC algorithm

- 0 = Enabled (default)
- 1 = Disabled

Note: If all 4 bits of the lower nibble are set to logic 1 (that is, no amplitude reference selected), then the front-end analog and digital gains are automatically set to nominal values of 2 and 2304, respectively.

If all 4 bits of the upper nibble are set to logic 1 (that is, no amplitude reference selected), then the back-end gain is set automatically to unity.

If the input sync height is greater than 100% and the AGC-adjusted output video amplitude becomes less than 100%, then the back-end scale factor attempts to increase the contrast in the back end to restore the video amplitude to 100%.

Table 2-74. F-Bit and V-Bit Control 2 Register

Subaddress	75h
Default	12h

7	6	5	4	3	2	1	0
Rabbit	Reserved		Fast lock	F and V [1:0]		Phase detector	HPLL

Rabbit:

Enable rabbit ear
0 = Disabled (default)
1 = Enabled

Fast lock:

Enable fast lock where vertical PLL is reset and a 2-second timer is initialized when vertical lock is lost; during time-out the detected input VSYNC is output.
0 = Disabled
1 = Enabled (default)

F and V [1:0]

F AND V	LINES PER FRAME	F BIT	V BIT
00 = (default)	Standard	ITU-R BT 656	ITU-R BT 656
	Nonstandard even	Forced to 1	Switch at field boundary
	Nonstandard odd	Toggles	Switch at field boundary
01 =	Standard	ITU-R BT 656	ITU-R BT 656
	Nonstandard	Toggles	Switch at field boundary
10 =	Standard	ITU-R BT 656	ITU-R BT 656
	Nonstandard	Pulsed mode	Switch at field boundary
11 =	Reserved		

Phase detector:

Enable integral window phase detector
0 = Disabled
1 = Enabled (default)

HPLL:

Enable horizontal PLL to free run
0 = Disabled (default)
1 = Enabled

Table 2-75. VCR Trick Mode Control Register

Subaddress	76h
Default	8Ah

7	6	5	4	3	2	1	0
Switch header	Horizontal shake threshold [6:0]						

Switch header:

When in VCR trick mode, the header noisy area around the head switch is skipped.
0 = Disabled
1 = Enabled (default)

Horizontal shake threshold [6:0]:

000 0000 = Zero threshold
000 1010 = 0Ah (default)
111 1111 = Largest threshold

Table 2-76. Horizontal Shake Increment Register

Subaddress	77h
Default	64h

7	6	5	4	3	2	1	0
Horizontal shake increment [7:0]							

Horizontal shake increment [7:0]:

000 0000 = 0 000

1010 = 64h (default)

111 1111 = FFh

Table 2-77. AGC Increment Speed Register

Subaddress	78h
Default	06h

7	6	5	4	3	2	1	0
Reserved					AGC increment speed [2:0]		

AGC increment speed [2:0]:

Adjusts gain increment speed.

111 = 7 (slowest)

110 = 6 (default)

⋮

000 = 0 (fastest)

Table 2-78. AGC Increment Delay Register

Subaddress	79h
Default	1Eh

7	6	5	4	3	2	1	0
AGC increment delay [7:0]							

AGC increment delay:

Number of frames to delay gain increments

1111 1111 = 255

⋮

0001 1110 = 30 (default)

⋮

0000 0000 = 0

Table 2-79. Analog Output Control 1 Register

Subaddress	7Fh
Default	00h

7	6	5	4	3	2	1	0
Reserved					AGC enable	Input select	Analog output enable

AGC enable:

0 = Enabled (default)

1 = Disabled, manual gain mode (see [Table 2-121](#))

Input select:

00 = Input selected by TVP5147M1 decoder (see [Table 2-12](#)) (default)01 = Input selected manually (see [Table 2-121](#))

Analog output enable:

0 = VI_1_A is input (default)

1 = VI_1_A is analog video output

Table 2-80. Chip ID MSB Register

Subaddress	80h						
	Read only						
7	6	5	4	3	2	1	0
CHIP ID MSB[7:0]							

CHIP ID MSB[7:0]:

This register identifies the MSB of the device ID. Value = 51h

Table 2-81. Chip ID LSB Register

Subaddress	81h						
	Read only						
7	6	5	4	3	2	1	0
CHIP ID LSB [7:0]							

CHIP ID LSB [7:0]:

This register identifies the LSB of the device ID. Value = 47h

Table 2-82. RAM Version LSB Register

Subaddress	82h						
	Read only						
7	6	5	4	3	2	1	0
RAM version LSB [7:0]							

RAM version LSB [7:0]:

This register identifies the LSB of the RAM code revision number.

Example:

Patch Release = v07.02.00

ROM Version = 07h

RAM Version MSB = 02h

RAM Version LSB = 00h

Table 2-83. Color PLL Speed Control Register

Subaddress	83h						
Default	09h						
7	6	5	4	3	2	1	0
Reserved				Speed[3:0]			

Speed [3:0]:

Color PLL speed control

1001 = Faster (default)

1010 =

1011 = Slower

Other = Reserved

Table 2-84. Status Request Register

Subaddress	97h						
Default	00h						
7	6	5	4	3	2	1	0
Reserved							Capture

Capture:

Setting a 1b in this register causes the internal processor to capture the current settings of the AGC status and the vertical line count registers. Because this capture is not immediate, it is necessary to check for completion of the capture by reading the capture bit repeatedly after setting it and waiting for it to be cleared by the internal processor. Once the capture bit is 0b, the AGC status and vertical line counters (3Ch/3Dh and 9Ah/9Bh) have been updated and can be safely read in any order.

Table 2-85. Vertical Line Count Register

Subaddress	9Ah–9Bh							
	Read only							
Subaddress	7	6	5	4	3	2	1	0
9Ah	Vertical line [7:0]							
9Bh	Reserved						Vertical line [9:8]	

Vertical line [9:0]:

Represent the detected a total number of lines from the previous frame. This can be used with nonstandard video signals such as a VCR in trick mode to synchronize downstream video circuitry.

Because this register is a double-byte register, it is necessary to capture the setting into the register to ensure that the value is not updated between reading the lower and upper bytes. To cause this register to capture the current settings, bit 0 of the status request register (subaddress 97h) must be set to a 1b. Once the internal processor has updated and can be read. Either byte may be read first since no further update occurs until bit 0 of 97h is set to 1b again.

Table 2-86. AGC Decrement Delay Register

Subaddress	9Eh							
Default	1Eh							
	7	6	5	4	3	2	1	0
	AGC decrement delay [7:0]							

AGC decrement delay:

Number of frames to delay gain decrements

1111 1111 = 255

⋮

0001 1110 = 30 (default)

⋮

0000 0000 = 0

Table 2-87. VDP TTX Filter and Mask Register

Subaddress	B1h	B2h	B3h	B4h	B5h	B6h	B7h	B8h	B9h	BAh
Default	00h	00h	00h	00h	00h	00h	00h	00h	00h	00h
Subaddress	7	6	5	4	3	2	1	0		
B1h	Filter 1 Mask 1				Filter 1 Pattern 1					
B2h	Filter 1 Mask 2				Filter 1 Pattern 2					
B3h	Filter 1 Mask 3				Filter 1 Pattern 3					
B4h	Filter 1 Mask 4				Filter 1 Pattern 4					
B5h	Filter 1 Mask 5				Filter 1 Pattern 5					
B6h	Filter 2 Mask 1				Filter 2 Pattern 1					
B7h	Filter 2 Mask 2				Filter 2 Pattern 2					
B8h	Filter 2 Mask 3				Filter 2 Pattern 3					
B9h	Filter 2 Mask 4				Filter 2 Pattern 4					
BAh	Filter 2 Mask 5				Filter 2 Pattern 5					

For an NABTS system, the packet prefix consists of five bytes. Each byte contains 4 data bits (D[3:0]) interlaced with 4 Hamming protection bits (H[3:0]):

Bit 7	Bit 6	Bit 5	Bit 4	Bit 3	Bit 2	Bit 1	Bit 0
D[3]	H[3]	D[2]	H[2]	D[1]	H[1]	D[0]	H[0]

Only the data portion D[3:0] from each byte is applied to a teletext filter function with corresponding pattern bits P[3:0] and mask bits M[3:0]. The filter ignores hamming protection bits.

For a WST system (PAL or NTSC), the packet prefix consists of two bytes. The two bytes contain three bits of magazine number (M[2:0]) and five bits of row address (R[4:0]), interlaced with eight Hamming protection bits H[7:0]:

Bit 7	Bit 6	Bit 5	Bit 4	Bit 3	Bit 2	Bit 1	Bit 0
R[0]	H[3]	M[2]	H[2]	M[1]	H[1]	M[0]	H[0]
R[4]	H[7]	R[3]	H[6]	R[2]	H[5]	R[1]	H[4]

The mask bits enable filtering using the corresponding bit in the pattern register. For example, a 1 in the LSB of mask 1 means that the filter module must compare the LSB of nibble 1 in the pattern register to the first data bit on the transaction. If these match, then a true result is returned. A 0 in a bit of mask means that the filter module must ignore that data bit of the transaction. If all 0s are programmed in the mask bits, then the filter matches all patterns returning a true result (default 00h).

Table 2-88. VDP TTX Filter Control Register

Subaddress	BBh						
Default	00h						
7	6	5	4	3	2	1	0
Reserved			Filter logic [1:0]		Mode	TTX filter 2 enable	TTX filter 1 enable

Filter logic [1:0]:

Allow different logic to be applied when combining the decision of Filter 1 and Filter 2 as follows:

00 = NOR (default)

01 = NAND

10 = OR

11 = AND

Mode:

Indicates which teletext mode is in use:

0 = Teletext filter applies to 2 header bytes (default)

1 = Teletext filter applies to 5 header bytes

TTX filter 2 enable:

Provides for enabling the teletext filter function within the VDP.

0 = Disable (default)

1 = Enable

TTX filter 1 enable:

Provides for enabling the teletext filter function within the VDP.

0 = Disable (default)

1 = Enable

If the filter matches or if the filter mask is all zeros, then a true result is returned.

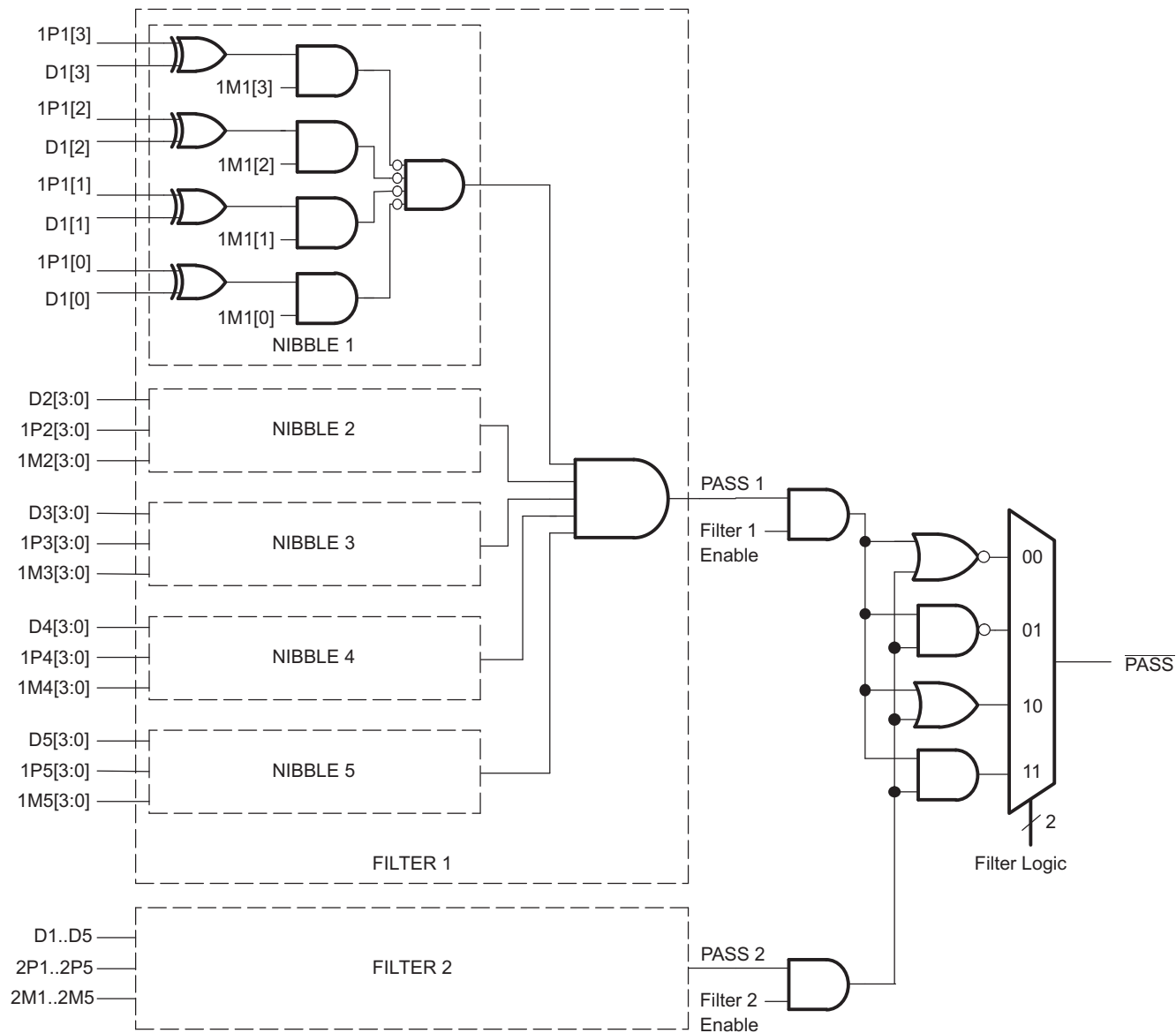

Figure 2-19. Teletext Filter Function

Table 2-89. VDP FIFO Word Count Register

Subaddress	BCh									
	Read only	7	6	5	4	3	2	1	0	
		FIFO word count [7:0]								

FIFO word count [7:0]:

This register provides the number of words in the FIFO.

Note: 1 word equals 2 bytes.

Table 2-90. VDP FIFO Interrupt Threshold Register

Subaddress	BDh
Default	80h

7	6	5	4	3	2	1	0
Threshold [7:0]							

Threshold [7:0]:

This register is programmed to trigger an interrupt when the number of words in the FIFO exceeds this value.

Note: 1 word equals 2 bytes.

Table 2-91. VDP FIFO Reset Register

Subaddress	BFh
Default	00h

7	6	5	4	3	2	1	0
Reserved							FIFO reset

FIFO reset:

Writing any data to this register clears the FIFO and VDP data register (CC, WSS, VITC and VPS). After clearing, this register is automatically cleared.

Table 2-92. VDP FIFO Output Control Register

Subaddress	C0h
Default	00h

7	6	5	4	3	2	1	0
Reserved							Host access enable

Host access enable:

This register is programmed to allow the host port access to the FIFO or allowing all VDP data to go out the video output.

0 = Output FIFO data to the video output Y[9:2] (default)

1 = Allow host port access to the FIFO data

Table 2-93. VDP Line Number Interrupt Register

Subaddress	C1h
Default	00h

7	6	5	4	3	2	1	0
Field 1 enable	Field 2 enable	Line number [5:0]					

Field 1 interrupt enable:

0 = Disabled (default)

1 = Enabled

Field 2 interrupt enable:

0 = Disabled (default)

1 = Enabled

Line number [5:0]:

Interrupt line number (default 00h)

This register is programmed to trigger an interrupt when the video line number exceeds this value in bits [5:0]. This interrupt must be enabled at address F4h.

Note: The line number value of zero or one is invalid and does not generate an interrupt.

Table 2-94. VDP Pixel Alignment Register

Subaddress	C2h–C3h							
Default	01Eh							
Subaddress	7	6	5	4	3	2	1	0
C2h	Pixel alignment [7:0]							
C3h	Reserved						Pixel alignment [9:0]	

Pixel alignment [9:0]:

These registers form a 10-bit horizontal pixel position from the falling edge of horizontal sync, where the VDP controller initiates the program from one line standard to the next line standard; for example, the previous line of teletext to the next line of closed caption. This value must be set so that the switch occurs after the previous transaction has cleared the delay in the VDP, but early enough to allow the new values to be programmed before the current settings are required.

The default value is 0x1E and has been tested with every standard supported here. A new value is needed only if a custom standard is in use.

Table 2-95. VDP Line Start Register

Subaddress	D6h							
Default	06h							
	7	6	5	4	3	2	1	0
	VDP line start [7:0]							

VDP line start [7:0]:

Sets the VDP line starting address for the global line mode register

This register must be set properly before enabling the line mode registers. The VDP processor works only the VBI region set by this register and the VDP line stop register.

Table 2-96. VDP Line Stop Register

Subaddress	D7h							
Default	1Bh							
	7	6	5	4	3	2	1	0
	VDP line stop [7:0]							

VDP line stop [7:0]:

Sets the VDP stop line.

Table 2-97. VDP Global Line Mode Register

Subaddress	D8h							
Default	FFh							
	7	6	5	4	3	2	1	0
	Global line mode [7:0]							

Global line mode [7:0]:

VDP processing for multiple lines set by VDP start line register D6h and stop line register D7h.

Global line mode register has the same bit definitions as the line mode registers (see [Table 2-119](#)).

General line mode has priority over the global line mode.

Table 2-98. VDP Full Field Enable Register

Subaddress	D9h						
Default	00h						
7	6	5	4	3	2	1	0
Reserved							Full field enable

Full field enable:

- 0 = Disabled full field mode(default)
- 1 = Enabled full field mode

This register enables the full field mode. In this mode, all lines outside the vertical blank area and all lines in the line mode register programmed with FFh are sliced with the definition of the VDP full field mode register at subaddress DAh. Values other than FFh in the line mode registers allow a different slice mode for that particular line.

Table 2-99. VDP Full Field Mode Register

Subaddress	DAh						
Default	FFh						
7	6	5	4	3	2	1	0
Full field mode [7:0]							

Full field mode [7:0]:

This register programs the specific VBI standard for full field mode. It can be any VBI standard. Individual line settings take priority over the full field register. This allows each VBI line to be programmed independently but have the remaining lines in full field mode. The full field mode register has the same bit definition as line mode registers (default FFh).

Global line mode has priority over the full field mode.

Table 2-100. VBUS Data Access With No VBUS Address Increment Register

Subaddress	E0h						
Default	00h						
7	6	5	4	3	2	1	0
VBUS data [7:0]							

VBUS data [7:0]:

VBUS data register for VBUS single byte read/write transaction.

Table 2-101. VBUS Data Access With VBUS Address Increment Register

Subaddress	E1h						
Default	00h						
7	6	5	4	3	2	1	0
VBUS data [7:0]							

VBUS data [7:0]:

VBUS data register for VBUS multi-byte read/write transaction. VBUS address is auto-incremented after each data byte read/write.

Table 2-102. FIFO Read Data Register

Subaddress	E2h						
	Read only						
7	6	5	4	3	2	1	0
FIFO Read Data [7:0]							

FIFO Read Data [7:0]:

This register is provided to access VBI FIFO data through the I²C interface. All forms of teletext data come directly from the FIFO, while all other forms of VBI data can be programmed to come from registers or from the FIFO. If the host port is to be used to read data from the FIFO, then bit 0 (host access enable) in the VDP FIFO output control register at subaddress C0h must be set to 1 (see [Table 2-92](#)).

Table 2-103. VBUS Address Register

Subaddress	E8h	E9h	EAh
Default	00h	00h	00h

Subaddress	7	6	5	4	3	2	1	0
E8h	VBUS address [7:0]							
E9h	VBUS address [15:8]							
EAh	VBUS address [23:16]							

VBUS address [23:0]:

VBUS is a 24-bit wide internal bus. The user needs to program in these registers the 24-bit address of the internal register to be accessed via host port indirect access mode.

Table 2-104. Interrupt Raw Status 0 Register

Subaddress	F0h
	Read only

7	6	5	4	3	2	1	0
FIFO THRS	TTX	WSS/CGMS	VPS/Gemstar	VITC	CC F2	CC F1	Line

The host Interrupt Raw Status 0 and Interrupt Raw Status 1 registers represent the interrupt status without applying mask bits.

FIFO THRS:

FIFO threshold passed, unmasked

0 = Not passed

1 = Passed

TTX:

Teletext data available unmasked

0 = Not available

1 = Available

WSS/CGMS:

WSS/CGMS data available unmasked

0 = Not available

1 = Available

VPS/Gemstar:

VPS/Gemstar data available unmasked

0 = Not available

1 = Available

VITC:

VITC data available unmasked

0 = Not available

1 = Available

CC F2:

CC field 2 data available unmasked

0 = Not available

1 = Available

CC F1:

CC field 1 data available unmasked

0 = Not available

1 = Available

Line:

Line number interrupt unmasked

0 = Not available

1 = Available

Table 2-105. Interrupt Raw Status 1 Register

Subaddress	F1h								
	Read only	7	6	5	4	3	2	1	0
		Reserved			H/V lock	Macrovision status changed	Standard changed	FIFO full	

H/V lock:

unmasked

0 = H/V lock status unchanged

1 = H/V lock status changed

Macrovision status changed:

unmasked

0 = Macrovision status unchanged

1 = Macrovision status changed

Standard changed:

unmasked

0 = Video standard unchanged

1 = Video standard changed

FIFO full:

0 = FIFO not full

1 = FIFO was full during write to FIFO

The FIFO full error flag is set when the current line of VBI data cannot enter the FIFO. For example, if the FIFO has only 10 bytes left and teletext is the current VBI line, then the FIFO full error flag is set, but no data is written because the entire teletext line does not fit. However, if the next VBI line is closed caption requiring only 2 bytes of data plus the header, then this goes into the FIFO even if the full error flag is set.

Table 2-106. Interrupt Status 0 Register

Subaddress	F2h						
	Read only						
7	6	5	4	3	2	1	0
FIFO THRS	TTX	WSS/CGMS	VPS/Gemstar	VITC	CC F2	CC F1	Line

Interrupt Status 0 and Interrupt Status 1 registers represent the interrupt status after applying mask bits. Therefore, the status bits are the result of a logical AND between the raw status and mask bits. The external interrupt terminal is derived from this register as an OR function of all nonmasked interrupts in this register.

Reading data from the corresponding register does not clear the status flags automatically. These flags are reset using the corresponding bits in the Interrupt Clear 0 and Interrupt Clear 1 registers.

FIFO THRS:

FIFO threshold passed, masked

0 = Not passed

1 = Passed

TTX:

Teletext data available masked

0 = Not available

1 = Available

WSS/CGMS:

WSS/CGMS data available masked

0 = Not available

1 = Available

VPS/Gemstar:

VPS/Gemstar data available masked

0 = Not available

1 = Available

VITC:

VITC data available masked

0 = Not available

1 = Available

CC F2:

CC field 2 data available masked

0 = Not available

1 = Available

CC F1:

CC field 1 data available masked

0 = Not available

1 = Available

Line:

Line number interrupt masked

0 = Not available

1 = Available

Table 2-107. Interrupt Status 1 Register

Subaddress	F3h						
	Read only						
7	6	5	4	3	2	1	0
Reserved				H/V lock	Macrovision status changed	Standard changed	FIFO full

H/V lock:

H/V lock status changed mask

0 = H/V lock status unchanged

1 = H/V lock status changed

Macrovision status changed:

Macrovision status changed masked

0 = Macrovision status not changed

1 = Macrovision status changed

Standard changed:

Standard changed masked

0 = Video standard not changed

1 = Video standard changed

FIFO full:

Masked status of FIFO

0 = FIFO not full

1 = FIFO was full during write to FIFO, see the interrupt mask 1 register at subaddress F5h for details (see [Table 2-109](#))

Table 2-108. Interrupt Mask 0 Register

Subaddress	F4h						
	Read only						
7	6	5	4	3	2	1	0
FIFO THRS	TTX	WSS/CGMS	VPS/Gemstar	VITC	CC F2	CC F1	Line

The host Interrupt Mask 0 and Interrupt Mask 1 registers can be used by the external processor to mask unnecessary interrupt sources for the Interrupt Status 0 and Interrupt Status 1 register bits, and for the external interrupt terminal. The external interrupt is generated from all nonmasked interrupt flags.

FIFO THRS:

FIFO threshold passed mask

0 = Disabled (default)

1 = Enabled FIFO_THRES interrupt

TTX:

Teletext data available mask

0 = Disabled (default)

1 = Enabled TTX available interrupt

WSS/CGMS:

WSS/CGMS data available mask

0 = Disabled (default)

1 = Enabled WSS/CGMS available interrupt

VPS/Gemstar:

VPS/Gemstar data available mask

0 = Disabled (default)

1 = Enabled VPS/Gemstar available interrupt

VITC:

VITC data available mask

0 = Disabled (default)

1 = Enabled VITC available interrupt

CC F2:

CC field 2 data available mask

0 = Disabled (default)

1 = Enabled CC field 2 available interrupt

CC F1:

CC field 1 data available mask

0 = Disabled (default)

1 = Enabled CC field 1 available interrupt

LINE:

Line number interrupt mask

0 = Disabled (default)

1 = Enabled Line_INT interrupt

Table 2-109. Interrupt Mask 1 Register

Subaddress	F5h						
	Read only						
7	6	5	4	3	2	1	0
Reserved				H/V lock	Macrovision status changed	Standard changed	FIFO full

H/V lock:

H/V lock status changed masked

0 = H/V lock status unchanged (default)

1 = H/V lock status changed

Macrovision status changed:

Macrovision status changed mask

0 = Macrovision status unchanged

1 = Macrovision status changed

Standard changed:

Standard changed mask

0 = Disabled (default)

1 = Enabled video standard changed

FIFO full:

FIFO full mask

0 = Disabled (default)

1 = Enabled FIFO full interrupt

Table 2-110. Interrupt Clear 0 Register

Subaddress	F6h						
	Read only						
7	6	5	4	3	2	1	0
FIFO THRS	TTX	WSS/CGMS	VPS/Gemstar	VITC	CC F2	CC F1	Line

The host Interrupt Clear 0 and Interrupt Clear 1 registers are used by the external processor to clear the interrupt status bits in the host Interrupt Status 0 and Interrupt Status 1 registers. When no nonmasked interrupts remain set in the registers, the external interrupt terminal also becomes inactive.

FIFO THRS:

FIFO threshold passed clear

0 = No effect (default)

1 = Clear FIFO_THRES bit in status register 0 bit 7

TTX:

Teletext data available clear

0 = No effect (default)

1 = Clear TTX available bit in status register 0 bit 6

WSS/CGMS:

WSS/CGMS data available clear

0 = No effect (default)

1 = Clear WSS/CGMS available bit in status register 0 bit 5

VPS/Gemstar:

VPS/Gemstar data available clear

0 = No effect (default)

1 = Clear VPS/Gemstar available bit in status register 0 bit 4

VITC:

VITC data available clear

0 = Disabled (default)

1 = Clear VITC available bit in status register 0 bit 3

CC F2:

CC field 2 data available clear

0 = Disabled (default)

1 = Clear CC field 2 available bit in status register 0 bit 2

CC F1:

CC field 1 data available clear

0 = Disabled (default)

1 = Clear CC field 1 available bit in status register 0 bit 1

LINE:

Line number interrupt clear

0 = Disabled (default)

1 = Clear Line interrupt available bit in status register 0 bit 0

Table 2-111. Interrupt Clear 1 Register

Subaddress	F7h						
	Read only						
7	6	5	4	3	2	1	0
Reserved				H/V lock	Macrovision status changed	Standard changed	FIFO full

H/V lock:

Clear H/V lock status changed flag

0 = H/V lock status unchanged

1 = H/V lock status changed

Macrovision status changed:

Clear Macrovision status changed flag

0 = No effect (default)

1 = Clear bit 2 (Macrovision status changed) in the interrupt status 1 register at subaddress F3h and the interrupt raw status 1 register at subaddress F1h

Standard changed:

Clear standard changed flag

0 = No effect (default)

1 = Clear bit 1 (video standard changed) in the interrupt status 1 register at subaddress F3h and the interrupt raw status 1 register at subaddress F1h

FIFO full:

Clear FIFO full flag

0 = No effect (default)

1 = Clear bit 0 (FIFO full flag) in the interrupt status 1 register at subaddress F3h and the interrupt raw status 1 register at subaddress F1h

2.12 VBUS Register Definitions**Table 2-112. VDP Closed Caption Data Register**

Subaddress	80 051Ch – 80 051Fh							
	Read only							
Subaddress	7	6	5	4	3	2	1	0
80 051Ch	Closed Caption Field 1 byte 1							
80 051Dh	Closed Caption Field 1 byte 2							
80 051Eh	Closed Caption Field 2 byte 1							
80 051Fh	Closed Caption Field 2 byte 2							

These registers contain the closed caption data arranged in bytes per field.

Table 2-113. VDP WSS Data Register

Subaddress	80 0520h – 80 0526h
	Read only

WSS NTSC (CGMS)

Subaddress	7	6	5	4	3	2	1	0	Byte
80 0520h			b5	b4	b3	b2	b1	b0	WSS Field 1 Byte 1
80 0521h	b13	b12	b11	b10	b9	b8	b7	b6	WSS Field 1 Byte 2
80 0522h			b19	b18	b17	b16	b15	b14	WSS Field 1 Byte 3
80 0523h	Reserved								
80 0524h			b5	b4	b3	b2	b1	b0	WSS Field 2 Byte 1
80 0525h	b13	b12	b11	b10	b9	b8	b7	b6	WSS Field 2 Byte 2
80 0526h			b19	b18	b17	b16	b15	b14	WSS Field 2 Byte 3

These registers contain the wide screen signaling data for NTSC.

Bits 0 – 1 represent word 0, aspect ratio

Bits 2 – 5 represent word 1, header code for word 2

Bits 6 – 13 represent word 2, copy control

Bits 14 – 19 represent word 3, CRC

PAL/SECAM

Subaddress	7	6	5	4	3	2	1	0	Byte
80 0520h	b7	b6	b5	b4	b3	b2	b1	b0	WSS Field 1 Byte 1
80 0521h			b13	b12	b11	b10	b9	b8	WSS Field 1 Byte 2
80 0522h	Reserved								
80 0523h	Reserved								
80 0524h	b7	b6	b5	b4	b3	b2	b1	b0	WSS Field 2 Byte 1
80 0525h			b13	b12	b11	b10	b9	b8	WSS Field 2 Byte 2
80 0526h	Reserved								

These registers contain the wide screen signaling data for PAL/SECAM:

Bits 0 – 3 represent Group 1, Aspect Ratio

Bits 4 – 7 represent Group 2, Enhanced Services

Bits 8 – 10 represent Group 3, Subtitles

Bits 11 – 13 represent Group 4, Others

Table 2-114. VDP VITC Data Register

Subaddress	80 052Ch – 80 0534h
	Read only

Subaddress	7	6	5	4	3	2	1	0
80 052Ch	VITC frame byte 1							
80 052Dh	VITC frame byte 2							
80 052Eh	VITC seconds byte 1							
80 052Fh	VITC seconds byte 2							
80 0530h	VITC minutes byte 1							
80 0531h	VITC minutes byte 2							
80 0532h	VITC hours byte 1							
80 0533h	VITC hours byte 2							
80 0534h	VITC CRC byte							

These registers contain the VITC data.

Table 2-115. VDP V-Chip TV Rating Block 1 Register

Subaddress	80 0540h
	Read only

7	6	5	4	3	2	1	0
Reserved	14-D	PG-D	Reserved	MA-L	14-L	PG-L	Reserved

TV Parental Guidelines Rating Block 3

14-D: When incoming video program is TV-14-D rated, this bit is set high.

PG-D: When incoming video program is TV-PG-D rated, this bit is set high.

MA-L: When incoming video program is TV-MA-L rated, this bit is set high.

14-L: When incoming video program is TV-14-L rated, this bit is set high.

PG-L: When incoming video program is TV-PG-L rated, this bit is set high.

Table 2-116. VDP V-Chip TV Rating Block 2 Register

Subaddress	80 0541h
	Read only

7	6	5	4	3	2	1	0
MA-S	14-S	PG-S	Reserved	MA-V	14-V	PG-V	Y7-FV

TV Parental Guidelines Rating Block 2

MA-S: When incoming video program is TV-MA-S rated, this bit is set high.

14-S: When incoming video program is TV-14-S rated, this bit is set high.

PG-S: When incoming video program is TV-PG-S rated, this bit is set high.

MA-V: When incoming video program is TV-MA-V rated, this bit is set high.

14-V: When incoming video program is TV-14-V rated, this bit is set high.

PG-V: When incoming video program is TV-PG-S rated, this bit is set high.

Y7-FV: When incoming video program is TV-Y7-FV rated, this bit is set high.

Table 2-117. VDP V-Chip TV Rating Block 3 Register

Subaddress	80 0542h
	Read only

7	6	5	4	3	2	1	0
None	TV-MA	TV-14	TV-PG	TV-G	TV-Y7	TV-Y	None

TV Parental Guidelines Rating Block 1

None: No block intended

TV-MA: When incoming video program is TV-MA rated in TV Parental Guidelines Rating, this bit is set high.

TV-14: When incoming video program is TV-14 rated in TV Parental Guidelines Rating, this bit is set high.

TV-PG: When incoming video program is TV-PG rated in TV Parental Guidelines Rating, this bit is set high.

TV-G: When incoming video program is TV-G rated in TV Parental Guidelines Rating, this bit is set high.

TV-Y7: When incoming video program is TV-Y7 rated in TV Parental Guidelines Rating, this bit is set high.

TV-Y: When incoming video program is TV-G rated in TV Parental Guidelines Rating, this bit is set high.

Table 2-118. VDP V-Chip MPAA Rating Data Register

Subaddress	80 0543h						
	Read only						
7	6	5	4	3	2	1	0
Not Rated	X	NC-17	R	PG-13	PG	G	NA

MPAA Rating Block (E5h)

Not Rated: When incoming video program is Not Rated rated in MPAA Rating, this bit is set high.

X: When incoming video program is X rated in MPAA Rating, this bit is set high.

NC-17: When incoming video program is NC-17 rated in MPAA Rating, this bit is set high.

R: When incoming video program is R rated in MPAA Rating, this bit is set high.

PG-13: When incoming video program is PG-13 rated in MPAA Rating, this bit is set high.

PG: When incoming video program is PG rated in MPAA Rating, this bit is set high.

G: When incoming video program is G rated in MPAA Rating, this bit is set high.

N/A: When incoming video program is N/A rated in MPAA Rating, this bit is set high.

Table 2-119. VDP General Line Mode and Line Address Register

Subaddress	80 0600h – 80 0611h
------------	---------------------

(default line mode = FFh, line address = 00h)

Subaddress	7	6	5	4	3	2	1	0
80 0600h								Line address 1
80 0601h								Line mode 1
80 0602h								Line address 2
80 0603h								Line mode 2
80 0604h								Line address 3
80 0605h								Line mode 3
80 0606h								Line address 4
80 0607h								Line mode 4
80 0608h								Line address 5
80 0609h								Line mode 5
80 060Ah								Line address 6
80 060Bh								Line mode 6
80 060Ch								Line address 7
80 060Dh								Line mode 7
80 060Eh								Line address 8
80 060Fh								Line mode 8
80 0610h								Line address 9
80 0611h								Line mode 9

Line address [7:0]: Line number to process selected line mode register on

Line mode x [7:0]

Bit 7

- 0 = Disabled filters
- 1 = Enabled filters for teletext and CC (null byte filter) (default)

Bit 6

- 0 = Send sliced VBI data to registers only
- 1 = Send sliced VBI data to FIFO and registers, teletext data only goes to FIFO (default)

Bit 5

- 0 = Allow VBI data with errors in the FIFO
- 1 = Do not allow VBI data with errors in the FIFO (default)

Bit 4

- 0 = Disabled error detection and correction
- 1 = Enabled error detection and correction (teletext only) (default)

Bit 3

- 0 = Field 1
- 1 = Field 2 (default)

Bit [2:0]

- 000 = Teletext (WST625, Chinese Teletext, NABTS 525)
- 001 = CC (US, European, Japan, China)
- 010 = WSS (525, 625)
- 011 = VITC
- 100 = VPS/PDC (PAL only), Gemstar (NTSC only)
- 101 = USER 1
- 110 = USER 2
- 111 = Reserved (active video) (default)

Table 2-120. VDP VPS/Gemstar Data Register

Subaddress	80 0700h – 80 070Ch
	Read only

VPS

Subaddress	7	6	5	4	3	2	1	0
80 0700h	VPS byte 1							
80 0701h	VPS byte 2							
80 0702h	VPS byte 3							
80 0703h	VPS byte 4							
80 0704h	VPS byte 5							
80 0705h	VPS byte 6							
80 0706h	VPS byte 7							
80 0707h	VPS byte 8							
80 0708h	VPS byte 9							
80 0709h	VPS byte 10							
80 070Ah	VPS byte 11							
80 070Bh	VPS byte 12							
80 070Ch	VPS byte 13							

These registers contain the entire VPS data line except the clock run-in code and the frame code.

Gemstar

Subaddress	7	6	5	4	3	2	1	0
80 0700h	Gemstar Frame Code							
80 0701h	Gemstar byte 1							
80 0702h	Gemstar byte 2							
80 0703h	Gemstar byte 3							
80 0704h	Gemstar byte 4							
80 0705h	Reserved							
80 0706h	Reserved							
80 0707h	Reserved							
80 0708h	Reserved							
80 0709h	Reserved							
80 070Ah	Reserved							
80 070Bh	Reserved							
80 070Ch	Reserved							

Table 2-121. Analog Output Control 2 Register

Subaddress	A0 005Eh						
Default	B2h						
7	6	5	4	3	2	1	0
Reserved		Input Select [1:0]		Gain[3:0]			

Analog input select [1:0]:

These bits are effective when manual input select bit is set to 1 at subaddress 7Fh, bit 1.

- 00 = CH1 selected
- 01 = CH2 selected
- 10 = CH3 selected
- 11 = CH4 selected (default)

Analog output PGA gain [3:0]:

These bits are effective when analog output AGC is disabled.

Gain[3:0] Mode 1

0000	1.30
0001	1.56
0010	1.82
(default)	
0011	2.08
0100	2.34
0101	2.60
0110	2.86
0111	3.12
1000	3.38
1001	3.64
1010	3.90
1011	4.16
1100	4.42
1101	4.68
1110	4.94
1111	5.20

Table 2-122. Interrupt Configuration Register

Subaddress	B0 0060h						
Default	00h						
7	6	5	4	3	2	1	0
Reserved					Polarity	Reserved	

Polarity:

Interrupt terminal polarity

- 0 = Active high (default)
- 1 = Active low

3 Electrical Specifications

3.1 Absolute Maximum Ratings

over operating free-air temperature range (unless otherwise noted) ⁽¹⁾

		MIN	MAX	UNIT		
IOVDD to IOGND	Supply voltage range	0.5	4	V		
DVDD to DGND		-0.2	2	V		
A33VDD ⁽²⁾ to A33GND ⁽³⁾		-0.3	3.6	V		
A18VDD ⁽⁴⁾ to A18GND ⁽⁵⁾		-0.2	2	V		
V _I to DGND	Digital input voltage range	-0.5	4.5	V		
V _O to DGND	Digital output voltage range	-0.5	4.5	V		
A _{IN} to AGND	Analog input voltage range	-0.2	2.0	V		
T _A	Operating free-air temperature	Commercial	0	70	°C	
		Industrial	-40	85		
T _{stg}	Storage temperature	-65	150	°C		
V _{ESD}	ESD stress voltage ⁽⁶⁾	Human-body model (HBM)	JEDEC ⁽⁷⁾	All pins	>1000	V
			AEC-Q100 ⁽⁸⁾	All pins	>1500	
				Excluding NC pins	>3000	
		Charged-device model (CDM)	JEDEC ⁽⁹⁾	All pins	>250	
			AEC-Q100 ⁽¹⁰⁾	All pins	>250	
				Excluding NC pins	>750	

(1) Stresses beyond those listed under *Absolute Maximum Ratings* may cause permanent damage to the device. These are stress ratings only and functional operation of the device at these or any other conditions beyond those indicated under *Recommended operating conditions* is not implied. Exposure to absolute-maximum-rated conditions for extended periods may affect device reliability.

(2) CH1_A33VDD, CH2_A33VDD

(3) CH1_A33GND, CH2_A33GND

(4) CH1_A18VDD, CH2_A18VDD, A18VDD, A18VDD_REF, PLL_A18VDD

(5) CH1_A18GND, CH2_A18GND, A18GND

(6) Electrostatic discharge (ESD) to measure device sensitivity/immunity to damage caused by electrostatic discharges into the device.

(7) Level listed is the passing level per ANSI/ESDA/JEDEC JS-001-2010. JEDEC document JEP155 states that 500-V HBM allows safe manufacturing with a standard ESD control process, and manufacturing with less than 500-V HBM is possible if necessary precautions are taken. Pins listed as 1000 V may actually have higher performance.

(8) Tested per AEC Q100-002 rev D

(9) Level listed is the passing level per EIA-JEDEC JESD22-C101E. JEDEC document JEP157 states that 250-V CDM allows safe manufacturing with a standard ESD control process. Pins listed as 250 V may actually have higher performance.

(10) Tested per AEC Q100-011 rev B

3.2 Recommended Operating Conditions

		MIN	NOM	MAX	UNIT	
IOV _{DD}	Supply voltage, digital	3	3.3	3.6	V	
DV _{DD}	Supply voltage, digital	Commercial	1.65	1.8	1.95	V
		Industrial	1.7	1.8	1.9	
AV _{DD33}	Supply voltage, analog	3	3.3	3.6	V	
AV _{DD18}	Supply voltage, analog	Commercial	1.65	1.8	1.95	V
		Industrial	1.7	1.8	1.9	
V _{I(P-P)}	Analog input voltage, analog (ac-coupling necessary)	0.5	1	2	V	
V _{IH}	Input voltage high, digital ⁽¹⁾	0.7 IOV _{DD}			V	
V _{IL}	Input voltage low, digital ⁽²⁾	0.3 IOV _{DD}			V	
I _{OH}	High-level output current ⁽³⁾	V _{OUT} = 2.4 V		–4	mA	
I _{OL}	Low-level output current	V _{OUT} = 2.4 V		4	mA	
T _A	Operating free-air temperature	Commercial	0		70	°C
		Industrial	–40		85	

(1) Exception: 0.7 AV_{DD18} for XIN terminal

(2) Exception: 0.3 AV_{DD18} for XIN terminal

(3) Currents out of a terminal are given as a negative number

3.3 Crystal Specifications

	MIN	NOM	MAX	UNIT
Frequency	14.31818			MHz
Frequency tolerance ⁽¹⁾	±50			ppm

(1) This number is the required specification for the external crystal/oscillator and is not tested.

3.4 Electrical Characteristics

For minimum/maximum values:

$$IOV_{DD} = 3\text{ V to }3.6\text{ V}, AV_{DD33} = 3\text{ V to }3.6\text{ V},$$

$$\text{Commercial: } AV_{DD18} = 1.65\text{ V to }1.95\text{ V}, DV_{DD} = 1.65\text{ V to }1.95\text{ V}, T_A = 0^\circ\text{C to }70^\circ\text{C}$$

$$\text{Industrial: } AV_{DD18} = 1.7\text{ V to }1.9\text{ V}, DV_{DD} = 1.7\text{ V to }1.9\text{ V}, T_A = -40^\circ\text{C to }85^\circ\text{C}$$

For typical values:

$$IOV_{DD} = AV_{DD33} = 3.3\text{ V}, AV_{DD18} = DV_{DD} = 1.8\text{ V}, T_A = 25^\circ\text{C}$$

3.5 DC Electrical Characteristics⁽¹⁾

PARAMETER		TEST CONDITIONS	MIN	TYP	MAX	UNIT
I _{DDIO(D)}	3.3-V IO digital supply current	CVBS		6		mA
		S-Video		6		
I _{DD(D)}	1.8-V digital supply current	CVBS		55		mA
		S-Video		55		
I _{DD(33A)}	3.3-V analog supply current	CVBS		24		mA
		S-Video		39		
I _{DD(18A)}	1.8-V analog supply current	CVBS		79		mA
		S-Video		135		
P _{TOT}	Total power dissipation, normal operation	S-Video		490		mW
P _{SAVE}	Total power dissipation, power save			100		mW
P _{DOWN}	Total power dissipation, power down			10		mW
I _{lkg}	Input leakage current				10	μA
C _I	Input capacitance ⁽²⁾				8	pF
V _{OH}	Output voltage high ⁽²⁾		0.8 IOV _{DD}			V
V _{OL}	Output voltage low ⁽²⁾			0.2 IOV _{DD}		V

(1) Measured with a load of 10 kΩ in parallel to 15 pF.

(2) Specified by design

3.6 Analog Processing and A/D Converters

F_S = 30 MSPS for CH1, CH2

PARAMETER		TEST CONDITIONS	MIN	TYP	MAX	UNIT
Z _i	Input impedance, analog video inputs ⁽¹⁾		200			kΩ
C _i	Input capacitance, analog video inputs ⁽¹⁾				10	pF
V _{i(PP)}	Input voltage range	C _{coupling} = 0.1 μF	0.5	1	2	V
ΔG	Input gain control range ⁽¹⁾		-6		6	dB
DNL	Differential nonlinearity	AFE only	-1	±0.75	+1	LSB
INL	Integral nonlinearity	AFE only	-2.5	±1	+2.5	LSB
FR	Frequency response	Multiburst (60 IRE)		-0.9		dB
XTALK	Crosstalk ⁽²⁾	1 MHz			-50	dB
SNR	Signal-to-noise ratio, all channels	1 MHz, 1 V _{PP}		54		dB
GM	Gain match ⁽¹⁾⁽³⁾	Full scale, 1 MHz		1.5		%
NS	Noise spectrum	Luma ramp (100 kHz to full, tilt null)		-58		dB
DP	Differential phase	Modulated ramp		0.5		°
DG	Differential gain	Modulated ramp		±1.5		%

(1) Specified by design

(2) By characterization only

(3) Component inputs only

3.7 Clocks, Video Data, Sync Timing

PARAMETER	TEST CONDITIONS	MIN	TYP	MAX	UNIT
Duty cycle, DATACLK		45	50	55	%
t_1	High time, DATACLK		18.5		ns
t_2	Low time, DATACLK		18.5		ns
t_3	Fall time, DATACLK	90% to 10%		4	ns
t_4	Rise time, DATACLK	10% to 90%		4	ns
t_5	Output delay time	Commercial		10	ns
		Industrial		12	

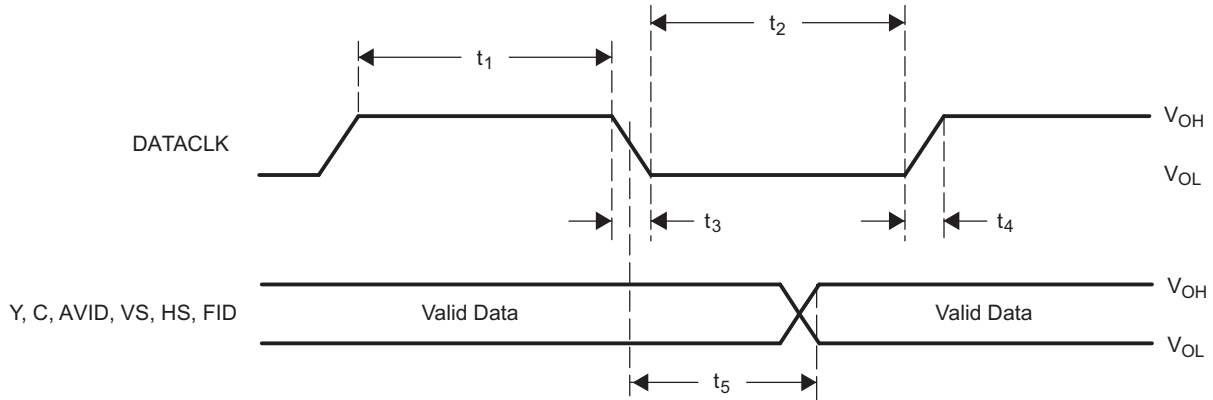

Figure 3-1. Clocks, Video Data, and Sync Timing

3.8 I²C Host Port Timing

PARAMETER	TEST CONDITIONS	MIN	TYP	MAX	UNIT
t_1	Bus free time between STOP and START	1.3			μ s
t_2	Data hold time	0		0.9	μ s
t_3	Data setup time	100			ns
t_4	Setup time for a (repeated) START condition	0.6			μ s
t_5	Setup time for a STOP condition	0.6			ns
t_6	Hold time (repeated) START condition	0.6			μ s
t_7	Rise time VC1(SDA) and VC0(SCL) signal			250	ns
t_8	Fall time VC1(SDA) and VC0(SCL) signal			250	ns
C_b	Capacitive load for each bus line			400	pF
f_{I2C}	I ² C clock frequency			400	kHz

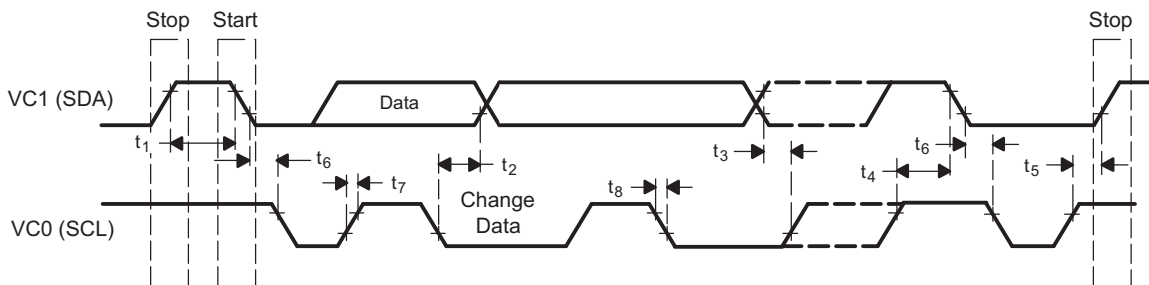

Figure 3-2. I²C Host Port Timing

3.9 Thermal Specifications

PARAMETER		TEST CONDITIONS ⁽¹⁾	MIN	TYP	MAX	UNIT
θ_{JA}	Junction-to-ambient thermal resistance, still air	Thermal pad soldered to 4-layer High-K PCB		19.04		°C/W
θ_{JC}	Junction-to-case thermal resistance, still air	Thermal pad soldered to 4-layer High-K PCB		0.17		°C/W
$T_{J(MAX)}$	Maximum junction temperature for reliable operation				105	°C

(1) The exposed thermal pad must be soldered to a High-K PCB with adequate ground plane.

4 Example Register Settings

The following example register settings are provided only as a reference. These settings (given the assumed input connector, video format, and output format) set the TVP5147M1 decoder and provide video output. Example register settings for other features and the VBI data processor are not provided here.

4.1 Example 1

4.1.1 Assumptions

Input connector: Composite (VI_1_A) (default)

Video format: NTSC (J, M), PAL (B, G, H, I, N) or SECAM (default)

Note: NTSC-443, PAL-Nc, PAL-M, and PAL-60 are masked from the autoswitch process by default. See the autoswitch mask register at address 04h.

Output format: 10-bit ITU-R BT.656 with embedded syncs (default)

4.1.2 Recommended Settings

Recommended I²C writes: For the given assumptions, only one write is required. All other registers are set up by default.

I²C register address 08h = Luminance processing control 3 register

I²C data 00h = Optimizes the trap filter selection for NTSC and PAL

I²C register address 0Eh = Chrominance processing control 2 register

I²C data 04h = Optimizes the chrominance filter selection for NTSC and PAL

I²C register address 34h = Output formatter 2 register

I²C data 11h = Enables YCbCr output and the clock output

Note: HS/CS, VS/VBLK, AVID, FID, and GLCO are logic inputs by default. See output formatter 3 and 4 registers at addresses 35h and 36h, respectively.

4.2 Example 2

4.2.1 Assumptions

Input connector: S-video [VI_2_C (luma), VI_1_C (chroma)]

Video format: NTSC (J, M, 443), PAL (B, D, G, H, I, N, Nc, 60) or SECAM (default)

Output format: 10-bit ITU-R BT.656 with discrete sync outputs

4.2.2 Recommended Settings

Recommended I²C writes: This setup requires additional writes to output the discrete sync 10-bit 4:2:2 data, HS, and VS, and to autoswitch between all video formats mentioned above.

I²C register address 00h = Input select register

I²C data 46h = Sets luma to VI_2_C and chroma to VI_1_C

I²C register address 04h = Autoswitch mask register

I²C data 3Fh = Includes NTSC 443 and PAL (M, Nc, 60) in the autoswitch

I²C register address 08h = Luminance processing control 3 register

I²C data 00h = Optimizes the trap filter selection for NTSC and PAL

I²C register address 0Eh = Chrominance processing control 2 register

I²C data 04h = Optimizes the chrominance filter selection for NTSC and PAL

I²C register address 33h = Output formatter 1 register

I²C data 41h = Selects the 10-bit 4:2:2 output format

I²C register address 34h = Output formatter 2 register

I²C data 11h = Enables YCbCr output and the clock output

I²C register address 36h = Output formatter 4 register

I²C data 11h = Enables HS and VS sync outputs

4.3 Example 3

4.3.1 Assumptions

Input connector: Component [VI_1_B (Pb), VI_2_B (Y), VI_3_B (Pr)]

Video format: 480I, 576I

Output format: 20-bit ITU-R BT.656 with discrete sync outputs

4.3.2 Recommended Settings

Recommended I²C writes: This setup requires additional writes to output the discrete sync 20-bit 4:2:2 data, HS, and VS, and to autoswitch between all video formats mentioned above.

I²C register address 00h = Input select register

I²C data 95h = Sets Pb to VI_1_B, Y to VI_2_B, and Pr to VI_3_B

I²C register address 04h = Autoswitch mask register

I²C data 3Fh = Includes NTSC 443 and PAL (M, Nc, 60) in the autoswitch

I²C register address 08h = Luminance processing control 3 register

I²C data 00h = Optimizes the trap filter selection for NTSC and PAL

I²C register address 0Eh = Chrominance processing control 2 register

I²C data 04h = Optimizes the chrominance filter selection for NTSC and PAL

I²C register address 33h = Output formatter 1 register

I²C data 41h = Selects the 20-bit 4:2:2 output format

I²C register address 34h = Output formatter 2 register

I²C data 11h = Enables YCbCr output and the clock output

I²C register address 36h = Output formatter 4 register

I²C data AFh = Enables HS and VS sync outputs

5 Application Information

5.1 Application Example

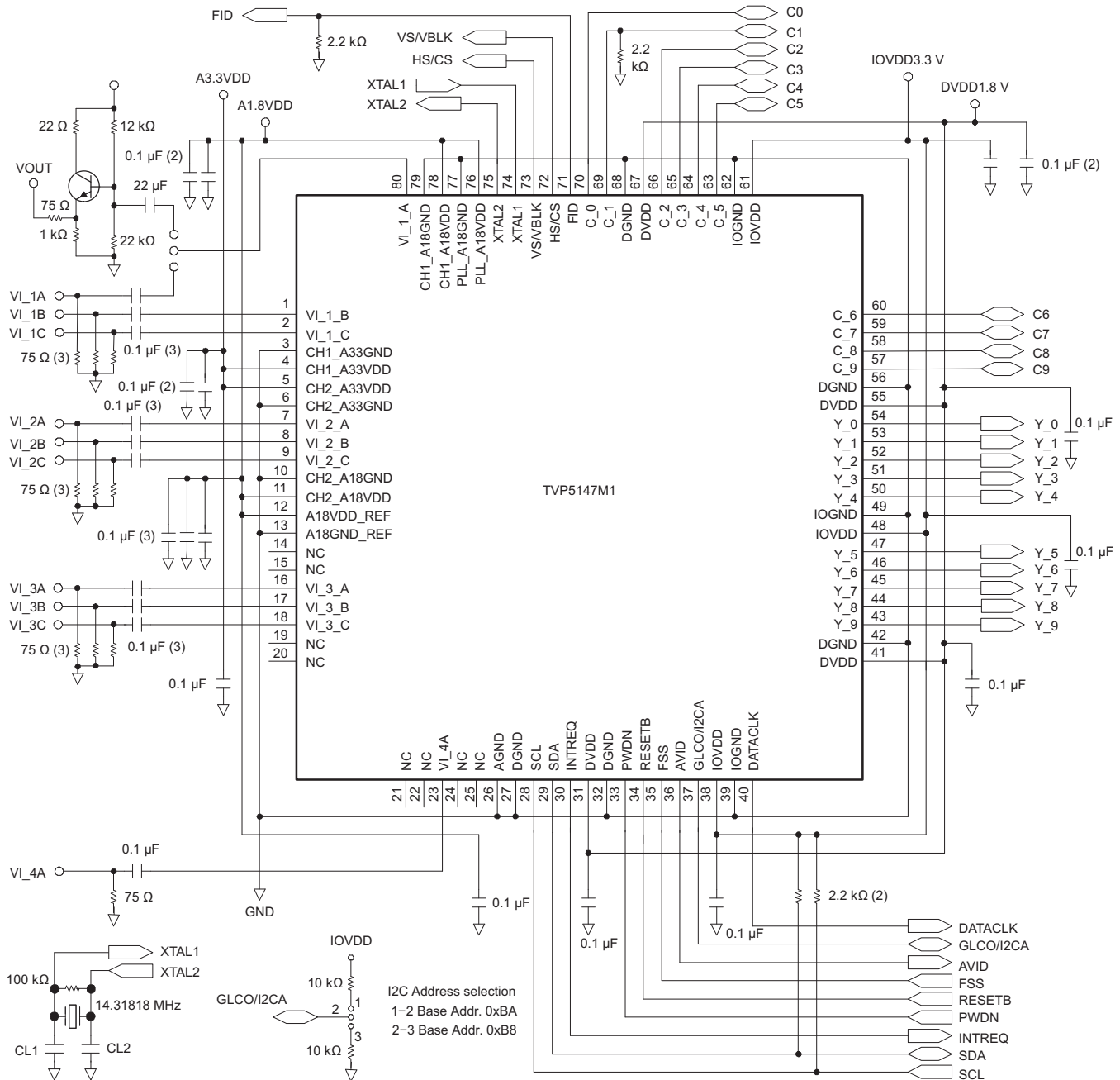

- If XTAL1 is connected to clock source, input voltage high must be 1.8 V.
- TVP5147 can be a drop-in replacement for TVP5146.
- Terminals 69 and 71 must be connected to ground through pull-down resistors.
- System level ESD protection is not included in this application circuit, but it is highly recommended on the analog video inputs.

Figure 5-1. Example Application Circuit

5.2 Designing With PowerPAD™ Devices

The TVP5147 device is housed in a high-performance, thermally enhanced, 80-terminal PowerPAD package (TI package designator: 80PFP). Use of the PowerPAD package does not require special considerations except to note that the thermal pad, which is an exposed die pad on the bottom of the device, is a metallic thermal and electrical conductor. Therefore, if not implementing the PowerPAD PCB features, the use of solder masks (or other assembly techniques) can be required to prevent any inadvertent shorting by the exposed thermal pad of connection etches or vias under the package. The recommended option, however, is not to run any etches or signal vias under the device, but to have only a grounded thermal land as in the following explanation. Although the actual size of the exposed die pad may vary, the minimum size required for the keep-out area for the 80-terminal PFP PowerPAD package is 8 mm × 8 mm.

It is recommended that there be a thermal land, which is an area of solder-tinned-copper, under the PowerPAD package. The thermal land varies in size, depending on the PowerPAD package being used, the PCB construction, and the amount of heat that needs to be removed. In addition, the thermal land may or may not contain numerous thermal vias, depending on PCB construction.

Other requirements for using thermal lands and thermal vias are detailed in the TI application report *PowerPAD™ Thermally Enhanced Package* (SLMA002), available via the TI web site at <http://www.ti.com>.

For the TVP5147 device, this thermal land must be grounded to the low-impedance ground plane of the device. This improves not only thermal performance but also the electrical grounding of the device. It is also recommended that the device ground terminal landing pads be connected directly to the grounded thermal land. The land size must be as large as possible without shorting device signal terminals. The thermal land can be soldered to the exposed thermal pad using standard reflow soldering techniques.

While the thermal land can be electrically floated and configured to remove heat to an external heat sink, it is recommended that the thermal land be connected to the low-impedance ground plane for the device. More information can be obtained from the TI application report *PHY Layout* (SLLA020).

Revision History

NOTE: Page numbers for previous revisions may differ from page numbers in the current version.

REVISION	COMMENTS
SLES140	Initial release
SLES140A	Updated Section 2.8
SLES140B	Added industrial temperature orderable and updated relevant specifications in Chapter 3 Updated Section 1.2
SLES140C	Updated Section 2.11.16, Section 2.11.17 Updated MAX supply voltages for Industrial temperature in Recommended Operating Conditions Added notes throughout Electrical Characteristics to indicate parameters specified by design or specified by characterization only Updated DNL Differential nonlinearity specification and INL Integral nonlinearity (page 80) Updated t5 Output delay time, Industrial (page 81)
SLES140D	Updated Section 2.8
SLES140E	Added AEC–Q100 qualification Changed all instances of 10–bit video decoder to 11–bit Updated register descriptions at addresses 09h, 0Ah, 0Bh Added registers at addresses 11h, 12h, 14h, 26h, 27h, 2Fh Changes all instances of WSS to WSS/CGMS and VPS to VPS/Gemstar Changed A18GND (pin 24) and A18VDD (pin 25) to NC Added Section 3.4 Thermal Specification Updated Figure 5-1 Example Application Circuit
SLES140F	Section 2.6.1, Removed statement about internal pulldown on I2CA terminal Modified thermal specification Added maximum ESD ratings Modified I ² C address 03h register and description Table 2-10, Added RAM version MSB and LSB registers (subaddresses: 71h, 82h) Table 2-72, Added RAM version MSB register (subaddress: 71h) Table 2-82, Added RAM version LSB register (subaddress: 82h) Minor editorial changes
SLES140G	Figure 2-10 , Changed figure and added note. Figure 2-12 and Figure 2-13 , Changed figures. Section 2.8 , Changed description concerning initializing VBUS register 0xA00014. Figure 5-1 , Added note concerning ESD protection.

PACKAGING INFORMATION

Orderable Device	Status (1)	Package Type	Package Drawing	Pins	Package Qty	Eco Plan (2)	Lead/Ball Finish	MSL Peak Temp (3)	Op Temp (°C)	Device Marking (4/5)	Samples
TVP5147M1IPFP	NRND	HTQFP	PFP	80	96	Green (RoHS & no Sb/Br)	CU NIPDAU	Level-3-260C-168 HR	-40 to 85	TVP5147M1I	
TVP5147M1IPFPR	NRND	HTQFP	PFP	80	1000	Green (RoHS & no Sb/Br)	CU NIPDAU	Level-3-260C-168 HR	-40 to 85	TVP5147M1I	
TVP5147M1PFP	NRND	HTQFP	PFP	80	96	Green (RoHS & no Sb/Br)	CU NIPDAU	Level-3-260C-168 HR	0 to 70	TVP5147M1	
TVP5147M1PFPR	NRND	HTQFP	PFP	80	1000	Green (RoHS & no Sb/Br)	CU NIPDAU	Level-3-260C-168 HR	0 to 70	TVP5147M1	

(1) The marketing status values are defined as follows:

ACTIVE: Product device recommended for new designs.

LIFEBUY: TI has announced that the device will be discontinued, and a lifetime-buy period is in effect.

NRND: Not recommended for new designs. Device is in production to support existing customers, but TI does not recommend using this part in a new design.

PREVIEW: Device has been announced but is not in production. Samples may or may not be available.

OBSELETE: TI has discontinued the production of the device.

(2) Eco Plan - The planned eco-friendly classification: Pb-Free (RoHS), Pb-Free (RoHS Exempt), or Green (RoHS & no Sb/Br) - please check <http://www.ti.com/productcontent> for the latest availability information and additional product content details.

TBD: The Pb-Free/Green conversion plan has not been defined.

Pb-Free (RoHS): TI's terms "Lead-Free" or "Pb-Free" mean semiconductor products that are compatible with the current RoHS requirements for all 6 substances, including the requirement that lead not exceed 0.1% by weight in homogeneous materials. Where designed to be soldered at high temperatures, TI Pb-Free products are suitable for use in specified lead-free processes.

Pb-Free (RoHS Exempt): This component has a RoHS exemption for either 1) lead-based flip-chip solder bumps used between the die and package, or 2) lead-based die adhesive used between the die and leadframe. The component is otherwise considered Pb-Free (RoHS compatible) as defined above.

Green (RoHS & no Sb/Br): TI defines "Green" to mean Pb-Free (RoHS compatible), and free of Bromine (Br) and Antimony (Sb) based flame retardants (Br or Sb do not exceed 0.1% by weight in homogeneous material)

(3) MSL, Peak Temp. -- The Moisture Sensitivity Level rating according to the JEDEC industry standard classifications, and peak solder temperature.

(4) There may be additional marking, which relates to the logo, the lot trace code information, or the environmental category on the device.

(5) Multiple Device Markings will be inside parentheses. Only one Device Marking contained in parentheses and separated by a "~" will appear on a device. If a line is indented then it is a continuation of the previous line and the two combined represent the entire Device Marking for that device.

Important Information and Disclaimer: The information provided on this page represents TI's knowledge and belief as of the date that it is provided. TI bases its knowledge and belief on information provided by third parties, and makes no representation or warranty as to the accuracy of such information. Efforts are underway to better integrate information from third parties. TI has taken and

continues to take reasonable steps to provide representative and accurate information but may not have conducted destructive testing or chemical analysis on incoming materials and chemicals. TI and TI suppliers consider certain information to be proprietary, and thus CAS numbers and other limited information may not be available for release.

In no event shall TI's liability arising out of such information exceed the total purchase price of the TI part(s) at issue in this document sold by TI to Customer on an annual basis.

MECHANICAL DATA

PFP (S-PQFP-G80)

PowerPAD™ PLASTIC QUAD FLATPACK

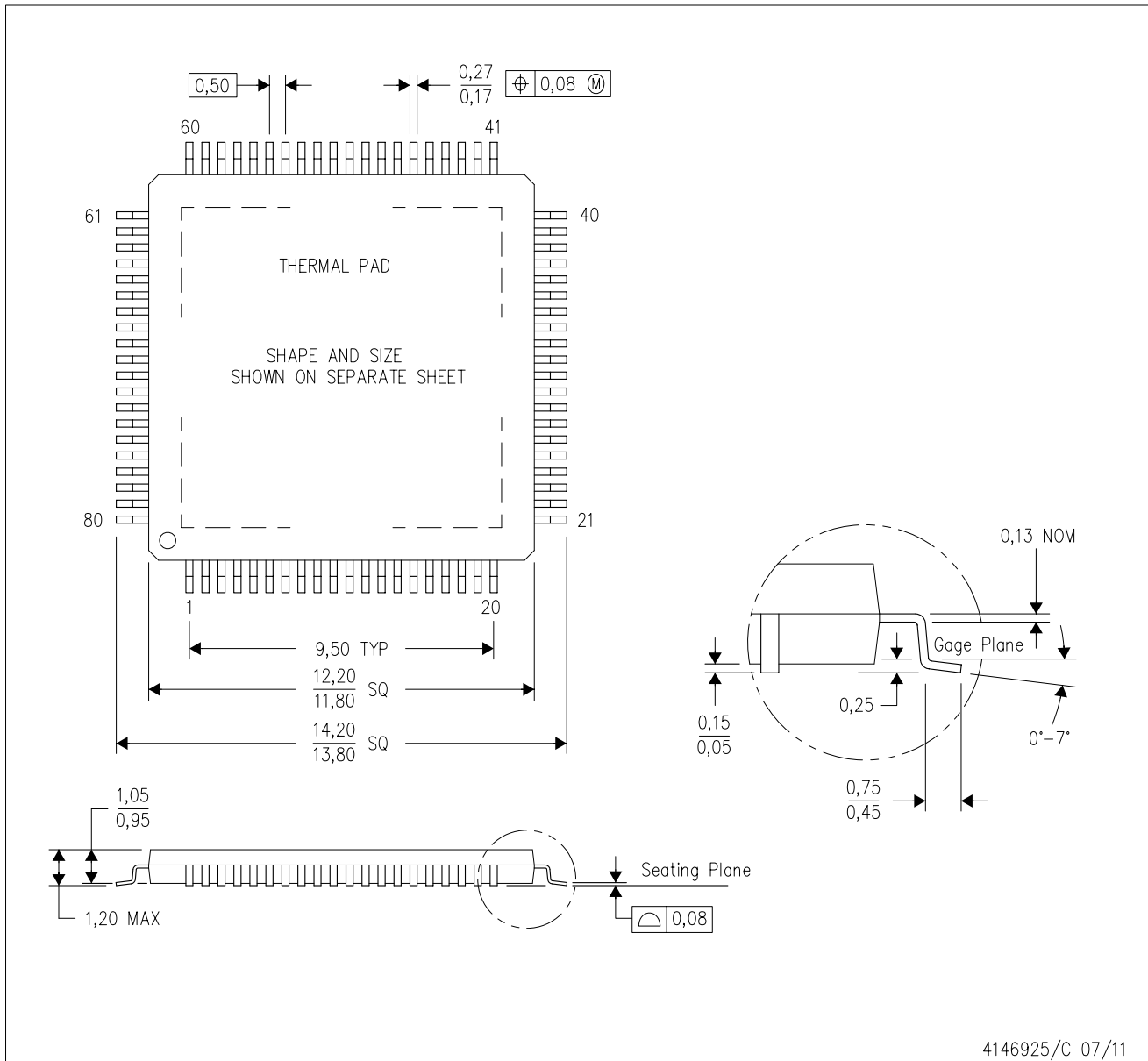

- NOTES:
- A. All linear dimensions are in millimeters.
 - B. This drawing is subject to change without notice.
 - C. Body dimensions do not include mold flash or protrusion
 - D. This package is designed to be soldered to a thermal pad on the board. Refer to Technical Brief, PowerPad Thermally Enhanced Package, Texas Instruments Literature No. SLMA002 for information regarding recommended board layout. This document is available at www.ti.com <<http://www.ti.com>>.
 - E. See the additional figure in the Product Data Sheet for details regarding the exposed thermal pad features and dimensions.
 - F. Falls within JEDEC MS-026

PowerPAD is a trademark of Texas Instruments.

THERMAL PAD MECHANICAL DATA

PFP (S-PQFP-G80)

PowerPAD™ PLASTIC QUAD FLATPACK

THERMAL INFORMATION

This PowerPAD™ package incorporates an exposed thermal pad that is designed to be attached to a printed circuit board (PCB). The thermal pad must be soldered directly to the PCB. After soldering, the PCB can be used as a heatsink. In addition, through the use of thermal vias, the thermal pad can be attached directly to the appropriate copper plane shown in the electrical schematic for the device, or alternatively, can be attached to a special heatsink structure designed into the PCB. This design optimizes the heat transfer from the integrated circuit (IC).

For additional information on the PowerPAD package and how to take advantage of its heat dissipating abilities, refer to Technical Brief, PowerPAD Thermally Enhanced Package, Texas Instruments Literature No. SLMA002 and Application Brief, PowerPAD Made Easy, Texas Instruments Literature No. SLMA004. Both documents are available at www.ti.com.

The exposed thermal pad dimensions for this package are shown in the following illustration.

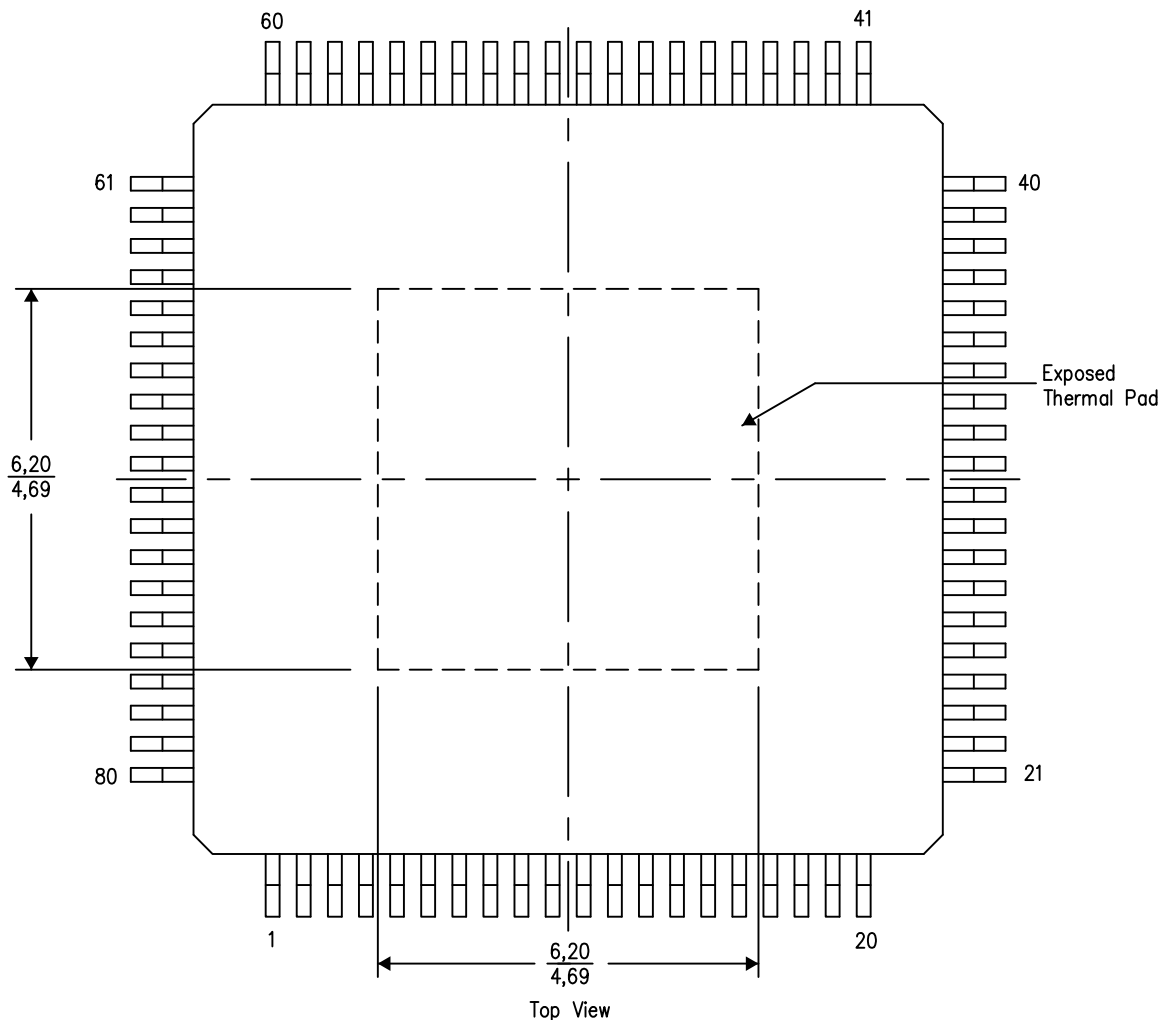

4206327-3/P 05/14

NOTE: A. All linear dimensions are in millimeters

PowerPAD is a trademark of Texas Instruments

LAND PATTERN DATA

PFP (S-PQFP-G80)

PowerPAD™ PLASTIC QUAD FLATPACK

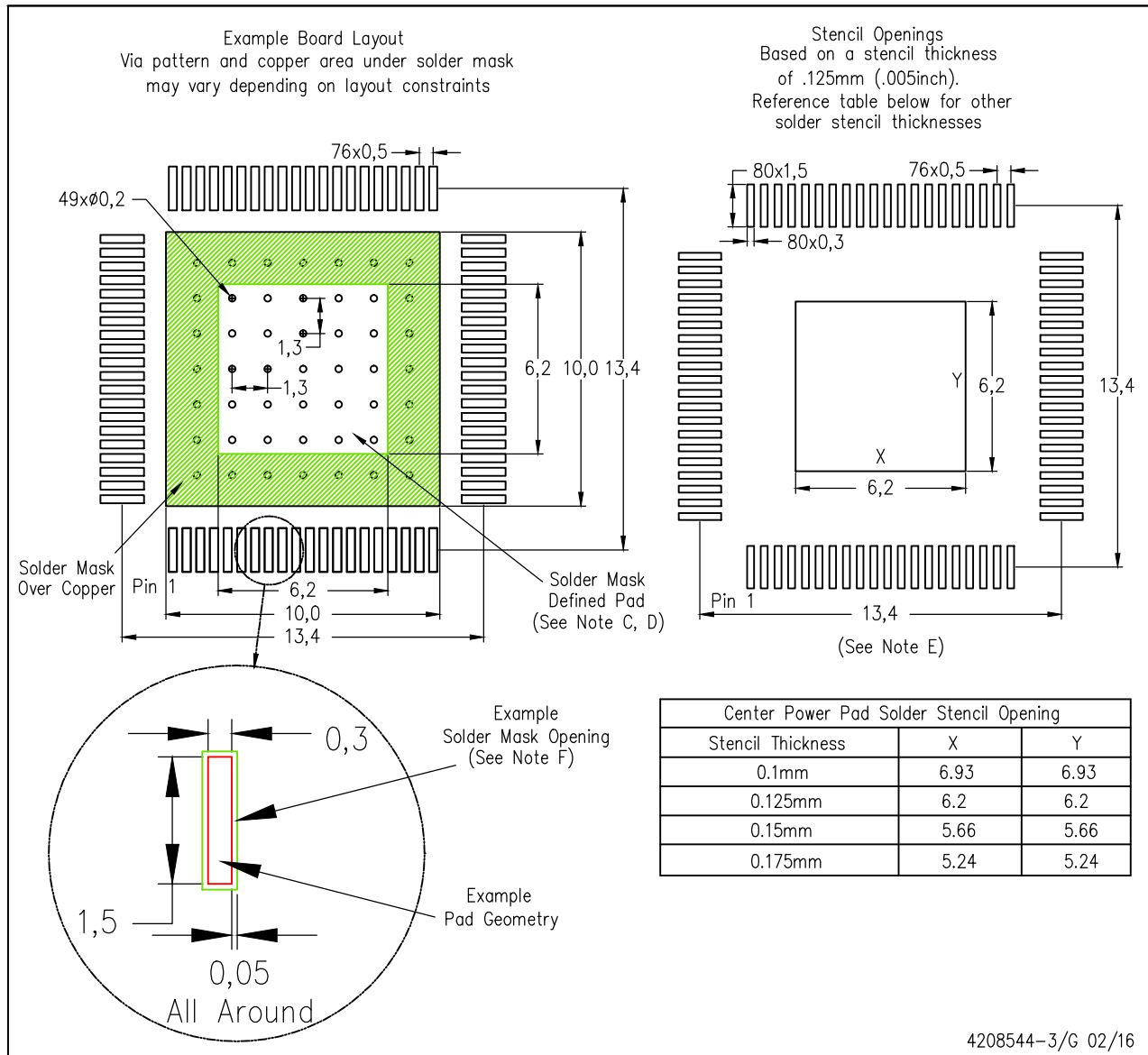

- NOTES:
- All linear dimensions are in millimeters.
 - This drawing is subject to change without notice.
 - Customers should place a note on the circuit board fabrication drawing not to alter the center solder mask defined pad.
 - This package is designed to be soldered to a thermal pad on the board. Refer to Technical Brief, PowerPad Thermally Enhanced Package, Texas Instruments Literature No. SLMA002, SLMA004, and also the Product Data Sheets for specific thermal information, via requirements, and recommended board layout. These documents are available at www.ti.com <<http://www.ti.com>>. Publication IPC-7351 is recommended for alternate designs.
 - Laser cutting apertures with trapezoidal walls and also rounding corners will offer better paste release. Customers should contact their board assembly site for stencil design recommendations. Example stencil design based on a 50% volumetric metal load solder paste. Refer to IPC-7525 for other stencil recommendations.
 - Customers should contact their board fabrication site for solder mask tolerances between and around signal pads.
- PowerPAD is a trademark of Texas Instruments.

IMPORTANT NOTICE

Texas Instruments Incorporated (TI) reserves the right to make corrections, enhancements, improvements and other changes to its semiconductor products and services per JESD46, latest issue, and to discontinue any product or service per JESD48, latest issue. Buyers should obtain the latest relevant information before placing orders and should verify that such information is current and complete.

TI's published terms of sale for semiconductor products (<http://www.ti.com/sc/docs/stdterms.htm>) apply to the sale of packaged integrated circuit products that TI has qualified and released to market. Additional terms may apply to the use or sale of other types of TI products and services.

Reproduction of significant portions of TI information in TI data sheets is permissible only if reproduction is without alteration and is accompanied by all associated warranties, conditions, limitations, and notices. TI is not responsible or liable for such reproduced documentation. Information of third parties may be subject to additional restrictions. Resale of TI products or services with statements different from or beyond the parameters stated by TI for that product or service voids all express and any implied warranties for the associated TI product or service and is an unfair and deceptive business practice. TI is not responsible or liable for any such statements.

Buyers and others who are developing systems that incorporate TI products (collectively, "Designers") understand and agree that Designers remain responsible for using their independent analysis, evaluation and judgment in designing their applications and that Designers have full and exclusive responsibility to assure the safety of Designers' applications and compliance of their applications (and of all TI products used in or for Designers' applications) with all applicable regulations, laws and other applicable requirements. Designer represents that, with respect to their applications, Designer has all the necessary expertise to create and implement safeguards that (1) anticipate dangerous consequences of failures, (2) monitor failures and their consequences, and (3) lessen the likelihood of failures that might cause harm and take appropriate actions. Designer agrees that prior to using or distributing any applications that include TI products, Designer will thoroughly test such applications and the functionality of such TI products as used in such applications.

TI's provision of technical, application or other design advice, quality characterization, reliability data or other services or information, including, but not limited to, reference designs and materials relating to evaluation modules, (collectively, "TI Resources") are intended to assist designers who are developing applications that incorporate TI products; by downloading, accessing or using TI Resources in any way, Designer (individually or, if Designer is acting on behalf of a company, Designer's company) agrees to use any particular TI Resource solely for this purpose and subject to the terms of this Notice.

TI's provision of TI Resources does not expand or otherwise alter TI's applicable published warranties or warranty disclaimers for TI products, and no additional obligations or liabilities arise from TI providing such TI Resources. TI reserves the right to make corrections, enhancements, improvements and other changes to its TI Resources. TI has not conducted any testing other than that specifically described in the published documentation for a particular TI Resource.

Designer is authorized to use, copy and modify any individual TI Resource only in connection with the development of applications that include the TI product(s) identified in such TI Resource. NO OTHER LICENSE, EXPRESS OR IMPLIED, BY ESTOPPEL OR OTHERWISE TO ANY OTHER TI INTELLECTUAL PROPERTY RIGHT, AND NO LICENSE TO ANY TECHNOLOGY OR INTELLECTUAL PROPERTY RIGHT OF TI OR ANY THIRD PARTY IS GRANTED HEREIN, including but not limited to any patent right, copyright, mask work right, or other intellectual property right relating to any combination, machine, or process in which TI products or services are used. Information regarding or referencing third-party products or services does not constitute a license to use such products or services, or a warranty or endorsement thereof. Use of TI Resources may require a license from a third party under the patents or other intellectual property of the third party, or a license from TI under the patents or other intellectual property of TI.

TI RESOURCES ARE PROVIDED "AS IS" AND WITH ALL FAULTS. TI DISCLAIMS ALL OTHER WARRANTIES OR REPRESENTATIONS, EXPRESS OR IMPLIED, REGARDING RESOURCES OR USE THEREOF, INCLUDING BUT NOT LIMITED TO ACCURACY OR COMPLETENESS, TITLE, ANY EPIDEMIC FAILURE WARRANTY AND ANY IMPLIED WARRANTIES OF MERCHANTABILITY, FITNESS FOR A PARTICULAR PURPOSE, AND NON-INFRINGEMENT OF ANY THIRD PARTY INTELLECTUAL PROPERTY RIGHTS. TI SHALL NOT BE LIABLE FOR AND SHALL NOT DEFEND OR INDEMNIFY DESIGNER AGAINST ANY CLAIM, INCLUDING BUT NOT LIMITED TO ANY INFRINGEMENT CLAIM THAT RELATES TO OR IS BASED ON ANY COMBINATION OF PRODUCTS EVEN IF DESCRIBED IN TI RESOURCES OR OTHERWISE. IN NO EVENT SHALL TI BE LIABLE FOR ANY ACTUAL, DIRECT, SPECIAL, COLLATERAL, INDIRECT, PUNITIVE, INCIDENTAL, CONSEQUENTIAL OR EXEMPLARY DAMAGES IN CONNECTION WITH OR ARISING OUT OF TI RESOURCES OR USE THEREOF, AND REGARDLESS OF WHETHER TI HAS BEEN ADVISED OF THE POSSIBILITY OF SUCH DAMAGES.

Unless TI has explicitly designated an individual product as meeting the requirements of a particular industry standard (e.g., ISO/TS 16949 and ISO 26262), TI is not responsible for any failure to meet such industry standard requirements.

Where TI specifically promotes products as facilitating functional safety or as compliant with industry functional safety standards, such products are intended to help enable customers to design and create their own applications that meet applicable functional safety standards and requirements. Using products in an application does not by itself establish any safety features in the application. Designers must ensure compliance with safety-related requirements and standards applicable to their applications. Designer may not use any TI products in life-critical medical equipment unless authorized officers of the parties have executed a special contract specifically governing such use. Life-critical medical equipment is medical equipment where failure of such equipment would cause serious bodily injury or death (e.g., life support, pacemakers, defibrillators, heart pumps, neurostimulators, and implantables). Such equipment includes, without limitation, all medical devices identified by the U.S. Food and Drug Administration as Class III devices and equivalent classifications outside the U.S.

TI may expressly designate certain products as completing a particular qualification (e.g., Q100, Military Grade, or Enhanced Product). Designers agree that it has the necessary expertise to select the product with the appropriate qualification designation for their applications and that proper product selection is at Designers' own risk. Designers are solely responsible for compliance with all legal and regulatory requirements in connection with such selection.

Designer will fully indemnify TI and its representatives against any damages, costs, losses, and/or liabilities arising out of Designer's non-compliance with the terms and provisions of this Notice.

Looking for pricing, stock, or lifecycle information?

Click below to explore more details on WIN SOURCE:

 [View TVP5147M1PFPR on WIN SOURCE](#)

 [Texas Instruments](#) Information

Optimize Your Supply Chain with WIN SOURCE Solutions

-  Global Sourcing Solution
-  Obsolete Management
-  Cost Control Management
-  Shortage Management
-  Alternative Solution
-  Excess Inventory Management