



THE DATASHEET OF TUSB6020PFC



TUSB6020 Evaluation Model (EVM) Compatible With TMS320C6437 DaVinci LC EVM

User's Guide



Literature Number: SLAU242
February 2008

TUSB6020 EVM

The TUSB6020 is a USB 2.0 high-speed, On-the-Go (OTG) high-performance dual-role USB controller with integrated PHY designed for a seamless connection to the VLYNQ serial interface, and is ideal for a wide range of applications. The USB OTG dual-role controller can operate either as a function controller for a USB peripheral or as the host/peripheral in point-to-point or multi-point communications with other functions. The integrated USB 2.0 PHY provides one-port operation at low speed (1.5 Mb/s), full speed (12 Mb/s), and high speed (480 Mb/s).

The device is fully compliant with *Universal Serial Bus Specification* Revision 2.0 and *On-The-Go Supplement to the USB 2.0 Specification* Revision 1.3.

The TUSB6020 EVM is compatible with several TI DSP platforms that are equipped with a mini-PCI interface with an active VLYNQ connection. This includes the DM6437 Digital Video Development Platform as well as the C6424 DSP Evaluation Module. The TUSB6020 EVM can provide a variety of USB functions to a DSP platform. Specifically, the TUSB6020 EVM has proven OTG host and OTG device capability. Alternatively, the TUSB6020 EVM can be configured to respond as a USB mass storage device.

1.1 TUSB6020 Connection Overview

Figure 1-1 shows a high-level diagram of the connections between the TUSB6020 and the various components on the TUSB6020 EVM, as well as the DSP platform.

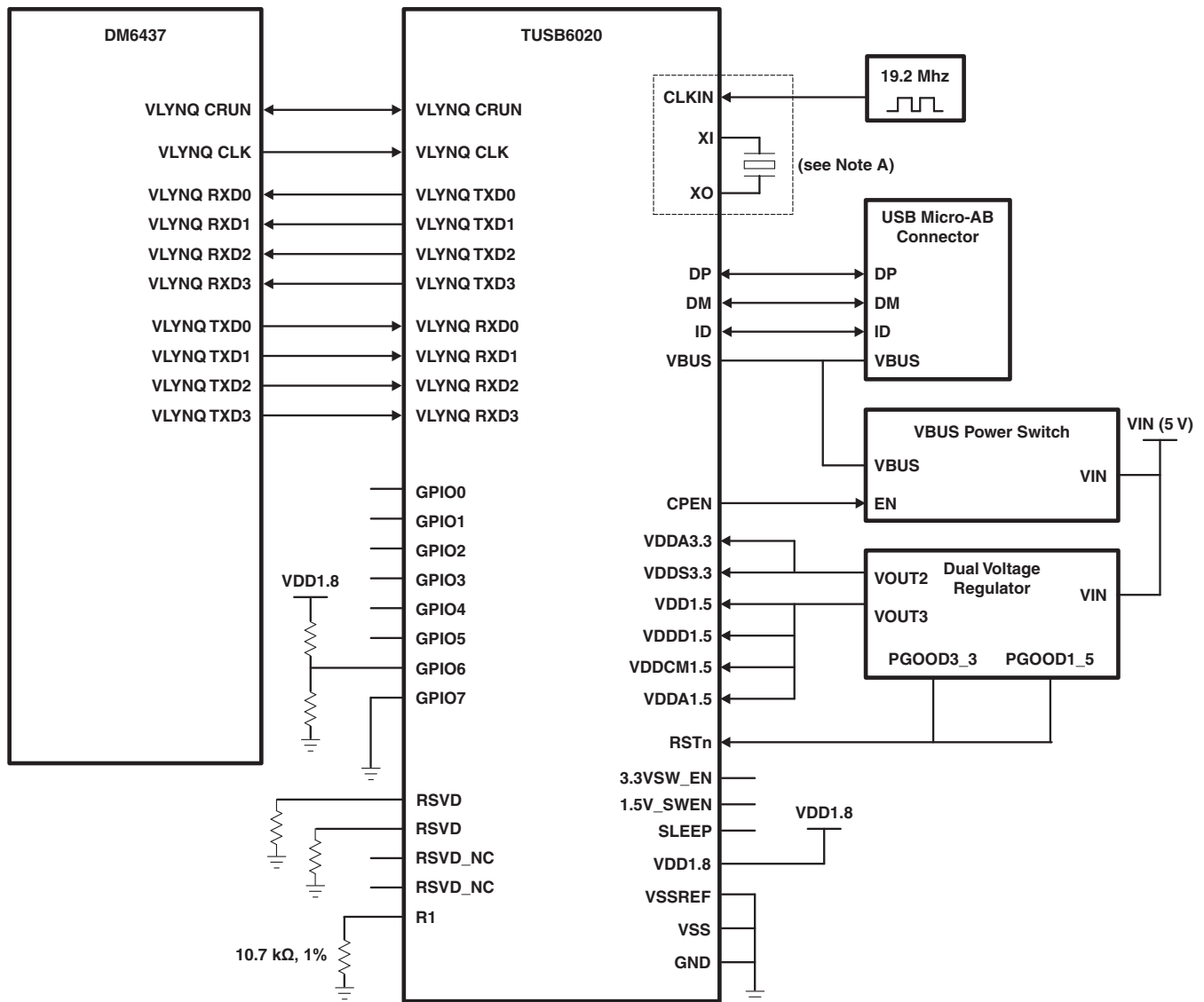

A Only CLKIN or XI/XO is required. This is selected by GPIO6 at power up.

Figure 1-1. TUSB6020 Connection Block Diagram

1.2 TUSB6020 EVM

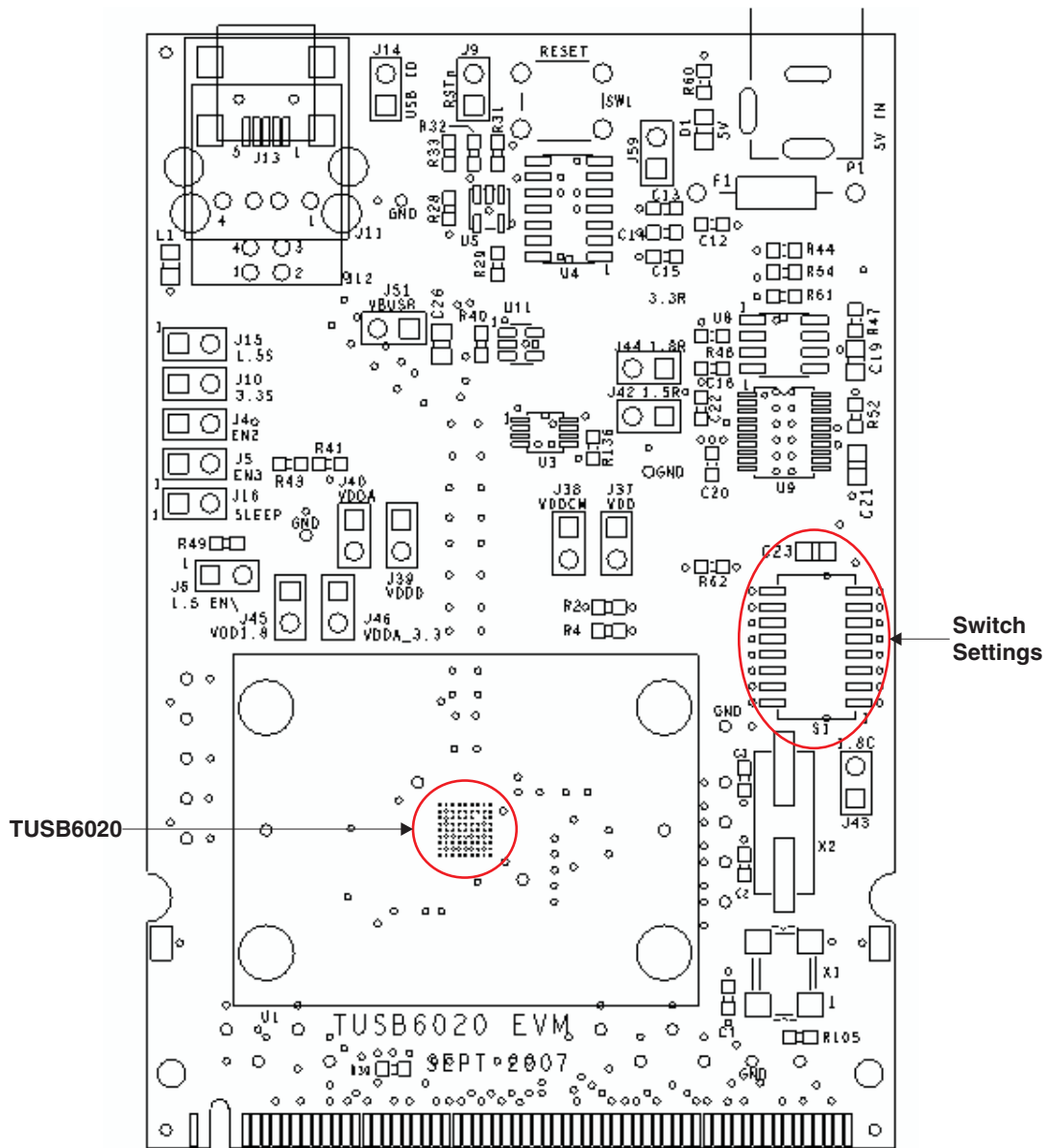

Figure 1-2. TUSB6020 EVM – Top Side

1.3 TUSB6020 EVM Features

- The TUSB6020 EVM is shipped with a USB mini-AB connector, J13, installed. There are also overlapping footprints on the EVM for a USB Standard A connector and a USB Standard B connector. If one of these options is needed, the mini-AB connector can be de-soldered from J13, and a B connector added to J12 or an A connector added to J11. There is also a jumper, J14, that allows for the ID pin of the mini-AB connector to be grounded for test purposes if installed.
- There are two clock source options available on the TUSB6020 EVM. There is a 24-MHz crystal clock source, X2, and a 19.2-MHz oscillator clock source, X1. The clock source used by the TUSB6020 is determined by the setting of Switch 7 of the toggle switch set, S1.
- The toggle switches at S1 connect to the GPIO7:0 pins of the TUSB6020. Switch 8 must be turned on at power-up (GPIO7 = low) for the TUSB6020 to operate properly. The setting of switch 7 at power up is used to determine the clock source. After power up, any of the switches can be used as inputs for the associated GPIOs.
- A reset to the TUSB6020 device can be generated in a variety of ways on the TUSB6020 EVM. A reset can be manually generated using the pushbutton installed at SW1. A reset is generated automatically based on the power-good outputs of the voltage regulator at power up. In addition, by installing jumper, J9, a reset can be generated and held by installing the jumper to ground.
- There are a number of test jumpers and test points on the TUSB6020 EVM that are not necessary to TUSB6020 EVM operation but could be used to test functionalities for use in production designs. Some of these are: the SLEEP jumper at J16, the 1.5V_SWEN jumper at J15, the 3.3V_SWEN jumper at J10, and the jumper on the level shifted version of CP_EN at J4.
- The power circuitry of the TUSB6020 EVM is set up to allow for easy power measurements. The 5-V power jack at P1 is not installed because the TUSB6020 can be powered by the DSP platform via the mini-PCI interface. To take a power measurement, the trace connecting the associated jumper pins should be cut and the jumper installed so that an ammeter can be inserted between the pins. See the schematic for particulars on voltage rails, but traces connect the jumper pins on the following: J37, J38, J39, J40, J42, J43, J45, J46, J51, and J59.

1.4 Quick Hardware Setup

1. Check that switches 7 and 8 in S1 are set to select the TUSB6020 normal device mode and the clock source. For normal operation, switch 8 must be turned on to pull GPIO7 low. Switch 7 must be turned on to select the X1 clock input (24 MHz) with GPIO6 pulled low or left off to select the CLKIN clock input (19.2 MHz) with GPIO6 pulled high.
2. Insert the TUSB6020 EVM into the mini-PCI slot of the unpowered TMS320C6437 or TMS320C6424 EVM.
3. Connect a UART cable from the TMS320C6437 EVM to a PC.
4. Connect a mini-USB cable from EMU-USB, J501, of the TMS320C6437 EVM to a PC loaded with the Code Composer, CCStudio v3.3, C6424 software.
5. Add wallpower to 5V IN, J14, of the TMS320C6437 EVM.
6. Check that LEDs, DS5 and DS502, are lit on the TMS320C6437 EVM.
7. Check that LED D1 is lit on the TUSB6020 EVM.

1.5 Quick Software Setup

1. Set up the COM port.

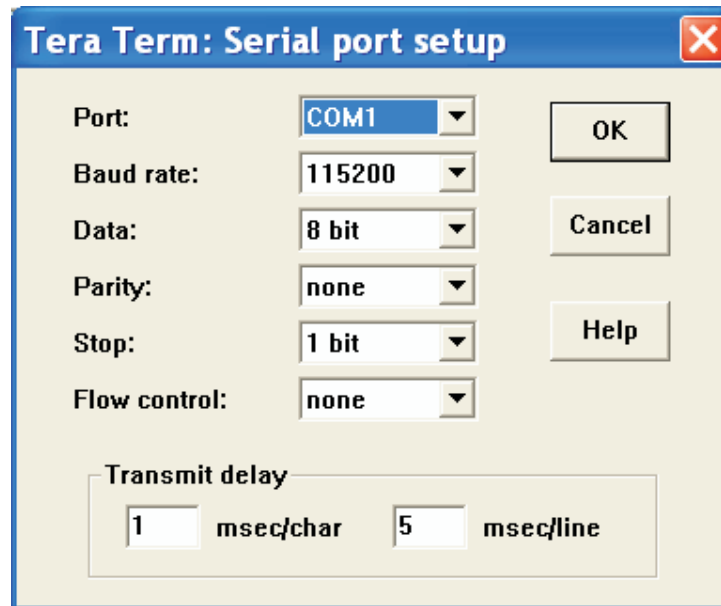

2. Start the Code Composer software select Debug → Connect.

3. Select File → Load program and select the program and then run it. On the COM port you should see:

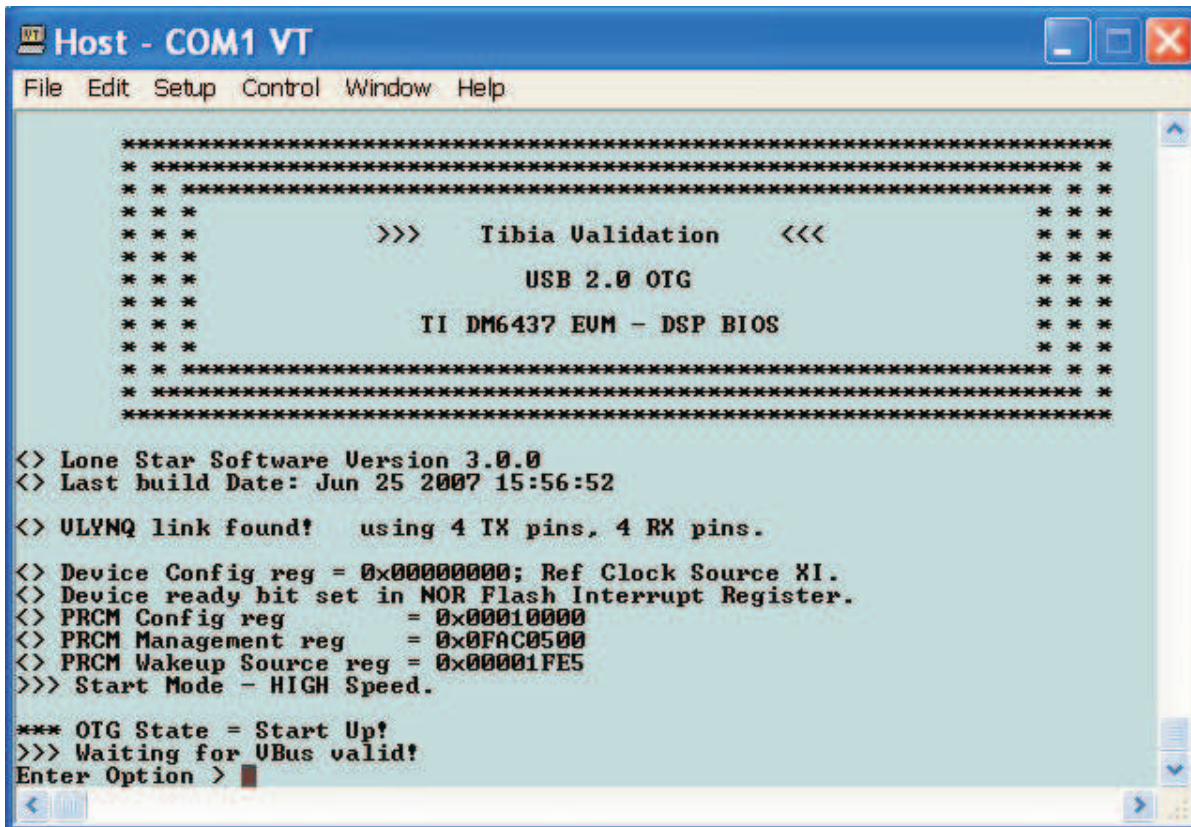

```

Host - COM1 VT
File Edit Setup Control Window Help

*****
* ****
* * ****
* * *
* * *          >>> Tibia Validation <<<          * * *
* * *          USB 2.0 OTG                        * * *
* * *          TI DM6437 EVM - DSP BIOS           * * *
* * * ****
* * ****
*****

<> Lone Star Software Version 3.0.0
<> Last build Date: Jun 25 2007 15:56:52
<> ULYNQ link found! using 4 TX pins, 4 RX pins.
<> Device Config reg = 0x00000000; Ref Clock Source XI.
<> Device ready bit set in NOR Flash Interrupt Register.
<> PRCM Config reg = 0x00010000
<> PRCM Management reg = 0x0FAC0500
<> PRCM Wakeup Source reg = 0x00001FE5
>>> Start Mode - HIGH Speed.

*** OTG State = Start Up!
>>> Waiting for UBus valid!
Enter Option > █
  
```

- Connect a USB cable from a PC to the TUSB6020 EVM. You should see the following on the COM port:

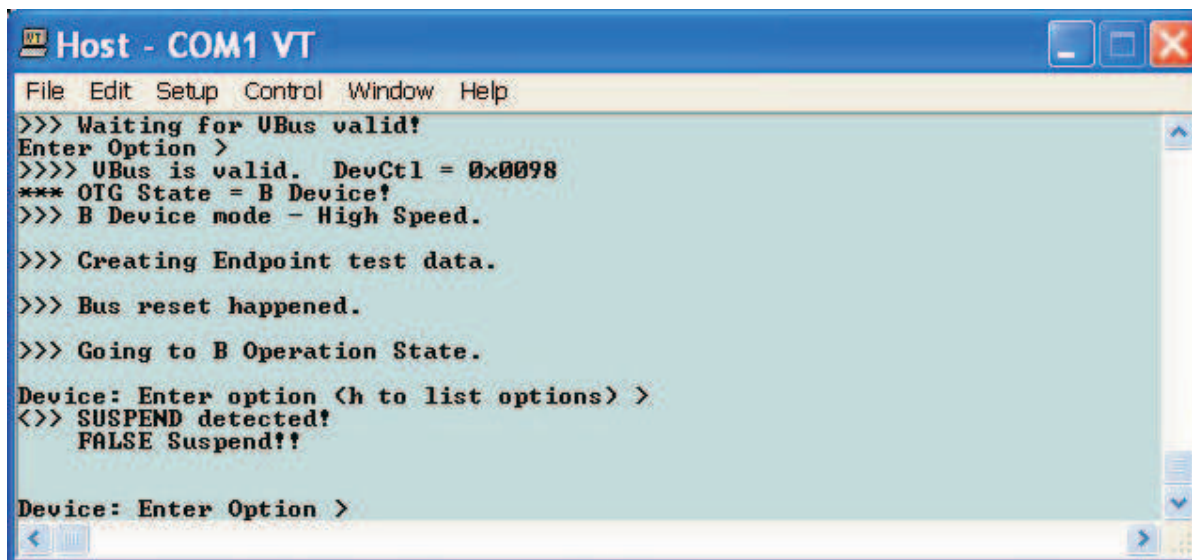

```

Host - COM1 VT
File Edit Setup Control Window Help
>>> Waiting for UBus valid!
Enter Option >
>>> UBus is valid. DevCtl = 0x0098
*** OTG State = B Device!
>>> B Device mode - High Speed.

>>> Creating Endpoint test data.

>>> Bus reset happened.

>>> Going to B Operation State.

Device: Enter option (h to list options) >
<>> SUSPEND detected!
    FALSE Suspend!!

Device: Enter Option >
    
```

- At the prompt, enter h to display a list of test options.

1.6 TUSB6020 EVM Features

Table 1-1. Bill of Materials and Schematics

ITEM	QUANTITY	REFERENCE	PART	PKG	MANUFACTURER	PART NO.	NOTES
1	10	C1, C28, C30, C38, C39, C42, C44, C53, C56, C59	.01 μ F	603			
2	2	C2, C3	33 pF	603			
3a	7	C12, C58, C6, C62, C63, C64, C65	10 μ F	603			
3b	3	C19, C21, C23, C13, C18, C20, C22, C27, C29, C37, C40, C41, C43, C54, C57	10 μ F, Tantalum	805			
4	15	C60, C66, C67	.1 μ F	603			
5	2	C14, C45	1 μ F	603			
6	1	C15	4.7 μ F	603			
7	1	C26	1 μ F	805			
8	1	D1	GREEN	805	Panasonic	LNJ306G5PRX	
9	1	F1	3A FUSE	N/A	Littelfuse	R251003	
10	19	J4, J5, J6, J9, J10, J14, J15, J16, J37, J38, J39, J40, J42, J43, J44, J45, J46, J51, J59	HDR2X1 M .1				DNI
11	1	J11	USB Series A	N/A			DNI
12	1	J12	USB Series B	N/A			DNI
13	1	J13	USB Mini/Micro AB		Mill-Max	MNE20-5G5P10	

Table 1-1. Bill of Materials and Schematics (continued)

ITEM	QUANTITY	REFERENCE	PART	PKG	MANUFACTURER	PART NO.	NOTES
14	23	J20, J21, J22, J23, J24, J25, J26, J27, J28, J29, J30, J31, J32, J33, J34, J35, J36, J54, J55, J56, J57, J58, J61	PAD				DNI
15	1	L1	INDUCTOR	mpz.pdf	TDK	MPZ2012S331AT	
16	1	P1	5 V at 3 A		CUI Inc	CP-202AH	
17	1	P2	128 pin Mini PCI Edge	N/A	N/A	N/A	DNI
18	1	R2	10.7K 1%	603			
19	15	R4, R30, R4, R106, R107, R108, R109, R110, R111, R112, R113, R114, R115, R123, R124	1K	603			
20	16	R28, R40, R43, R49, R61, R62, R105, R116, R117, R118, R119, R120, R121, R122, R135, R136	10K	603			
21	4	R29, R31, R32, R48	0	603			
22	1	R33	0	603			DNI
23	4	R44, R47, R52, R54	250K	603			
24	1	R60	330	603			
25	1	SW1	SW TACT		Alps	SKHHALA010	
26	1	S1	SW DIP-8		ITT	TDA08H0SK1R	
27	1	U1	TUSB6020	ZQE80	TI	TUSB6020ZQE	
28	1	U3	SN74LVC2T45, Dual Bit/Supply Transceiver	SM8	TI	SN74LVC2T45DCTR	
29	1	U4	SN74ALVC08, Multiple AND Gate	SOIC14	TI	SN74ALVC08D	
30	1	U5	TPS3836E18, Reset Supervisor	5SOT-23	TI	TPS3836E18	
31	1	U8	TPS77618, 1.8 V Regulator	SOIC8	TI	TPS77618D	
32	1	U9	TPS70848, Dual Voltage Regulator	SM20	TI	TPS70848PWP	
33	1	U11	TPS2051B, V _{BUS} Power Switch	DBV5	TI	TPS2051BDBV	
34	1	X1	19.2 MHz, CSX-1	SMT	Crystek	601512	
35	1	X2	24 MHz, C _L = 20 pF	SMT	Crystek	16808	

1.7 TUSB6020 Schematics

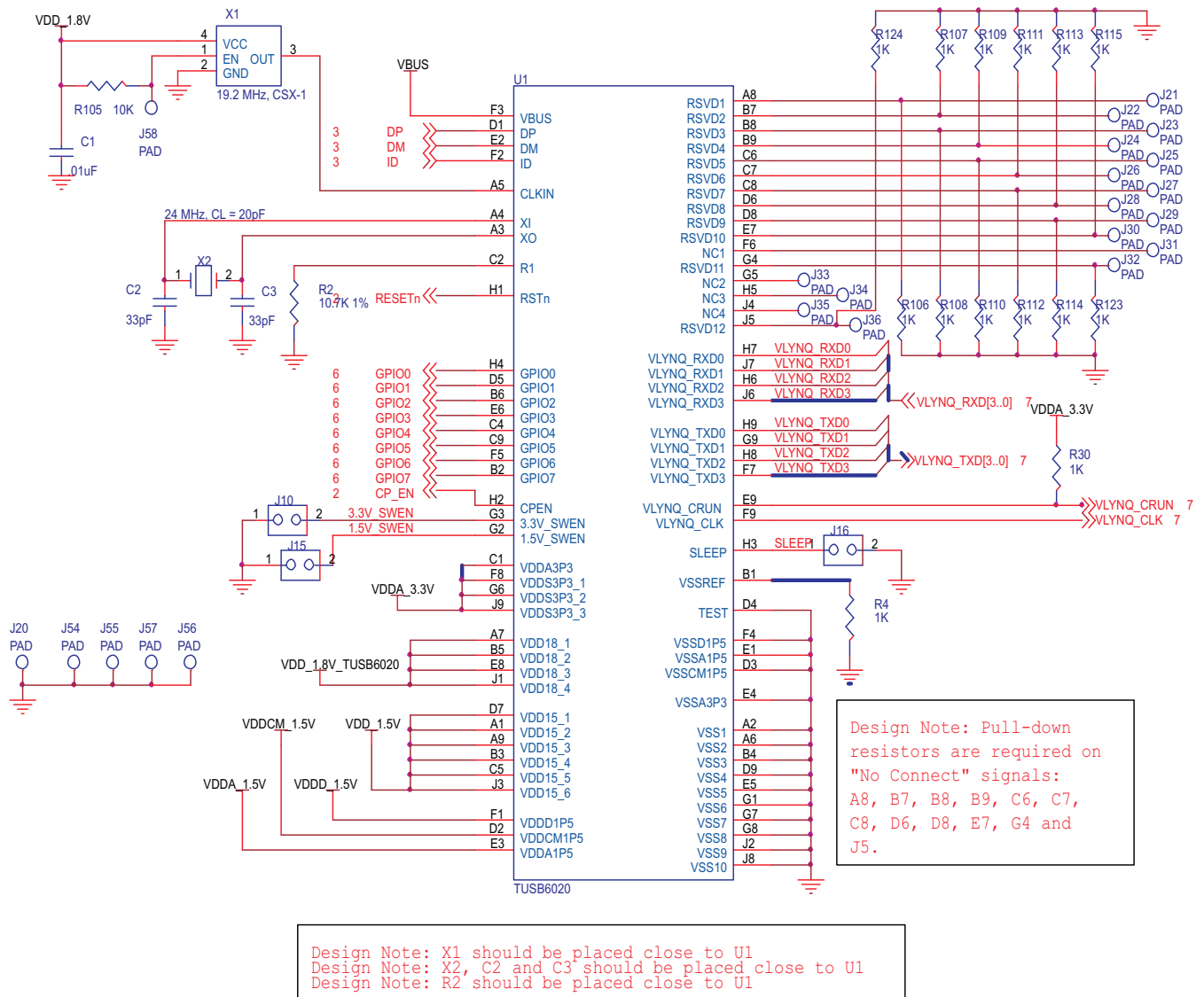

Figure 1-3. TUSB6020

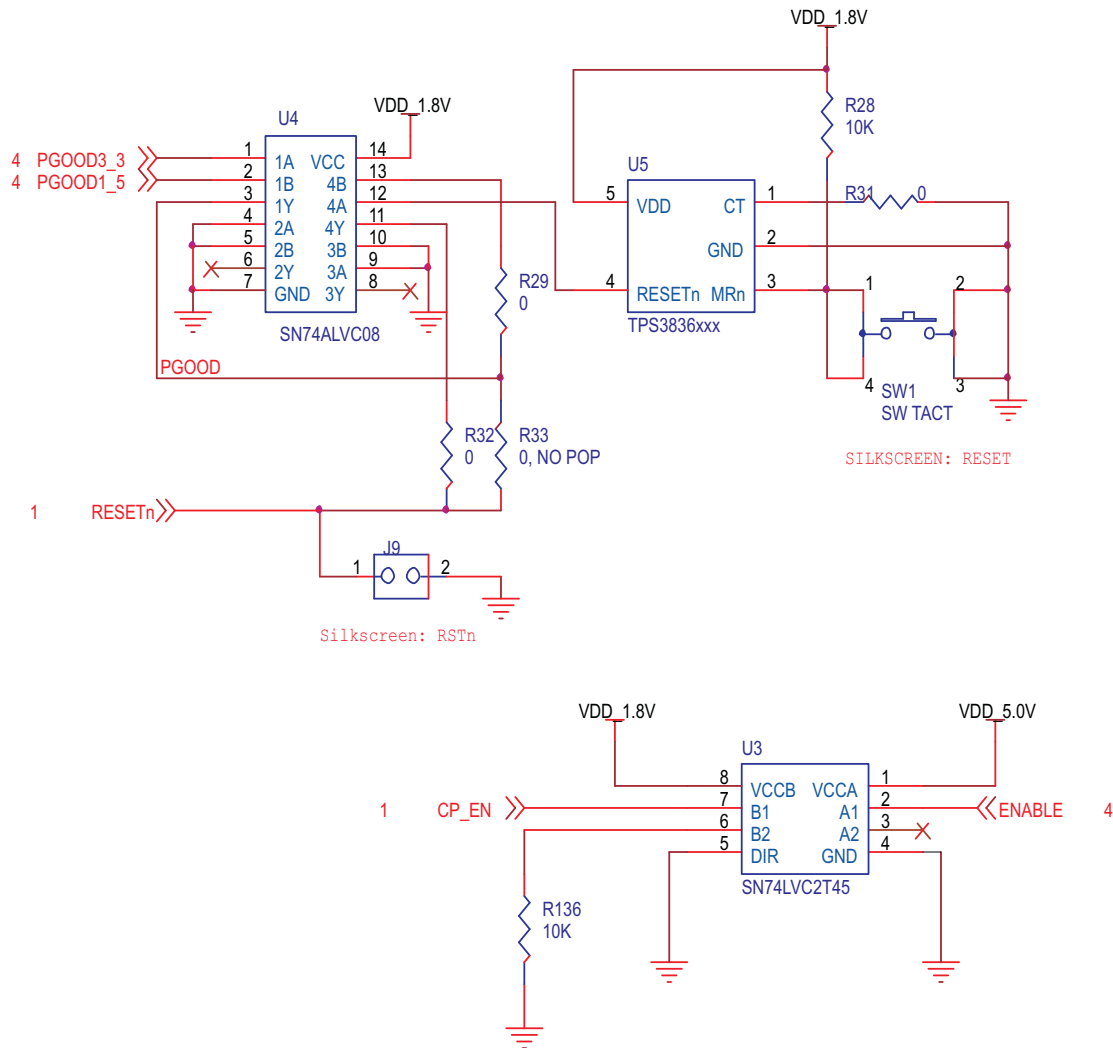
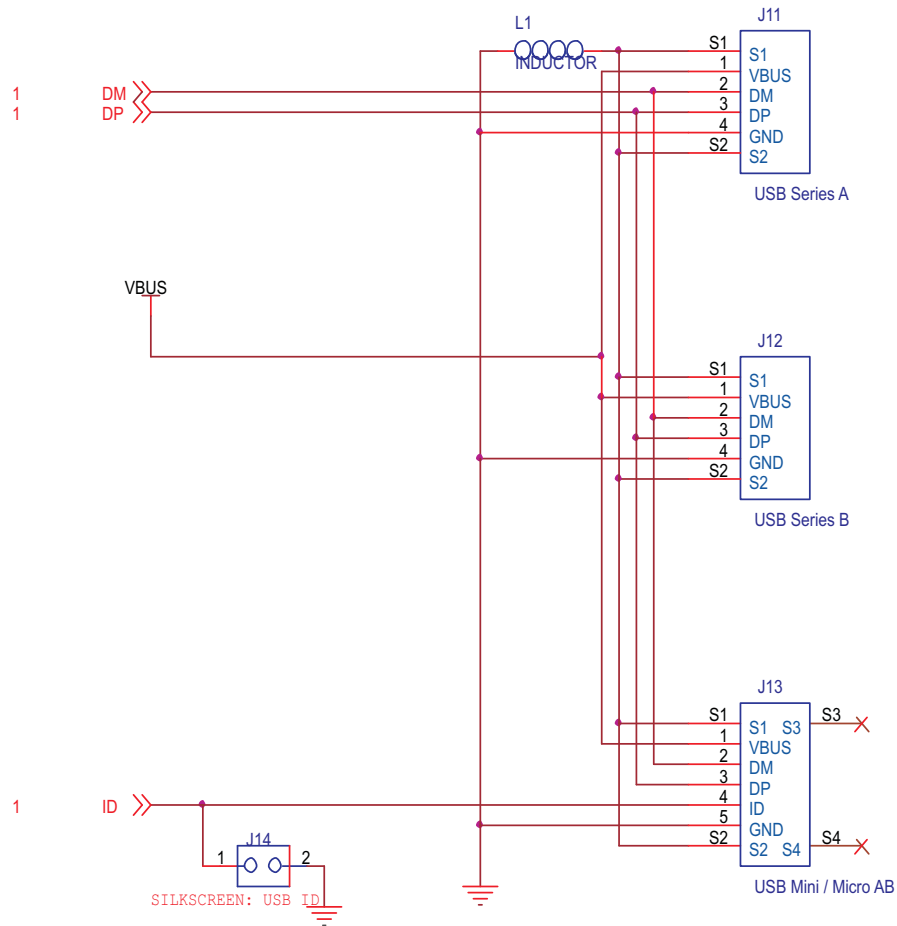

Figure 1-4. Reset



PLACEMENT NOTES: OVERLAP SHORTED USB SERIES A, SERIES B, AND MINI / MICRO AB FOOTPRINTS. ROUTE DP/DM LINES ON TOP LAYER OF BOARD AS 90 OHM DIFFERENTIAL PAIRS. SURROUND DP/DM LINES WITH GROUND PLANE AND GROUND VIAS.

Figure 1-5. USB Connectors

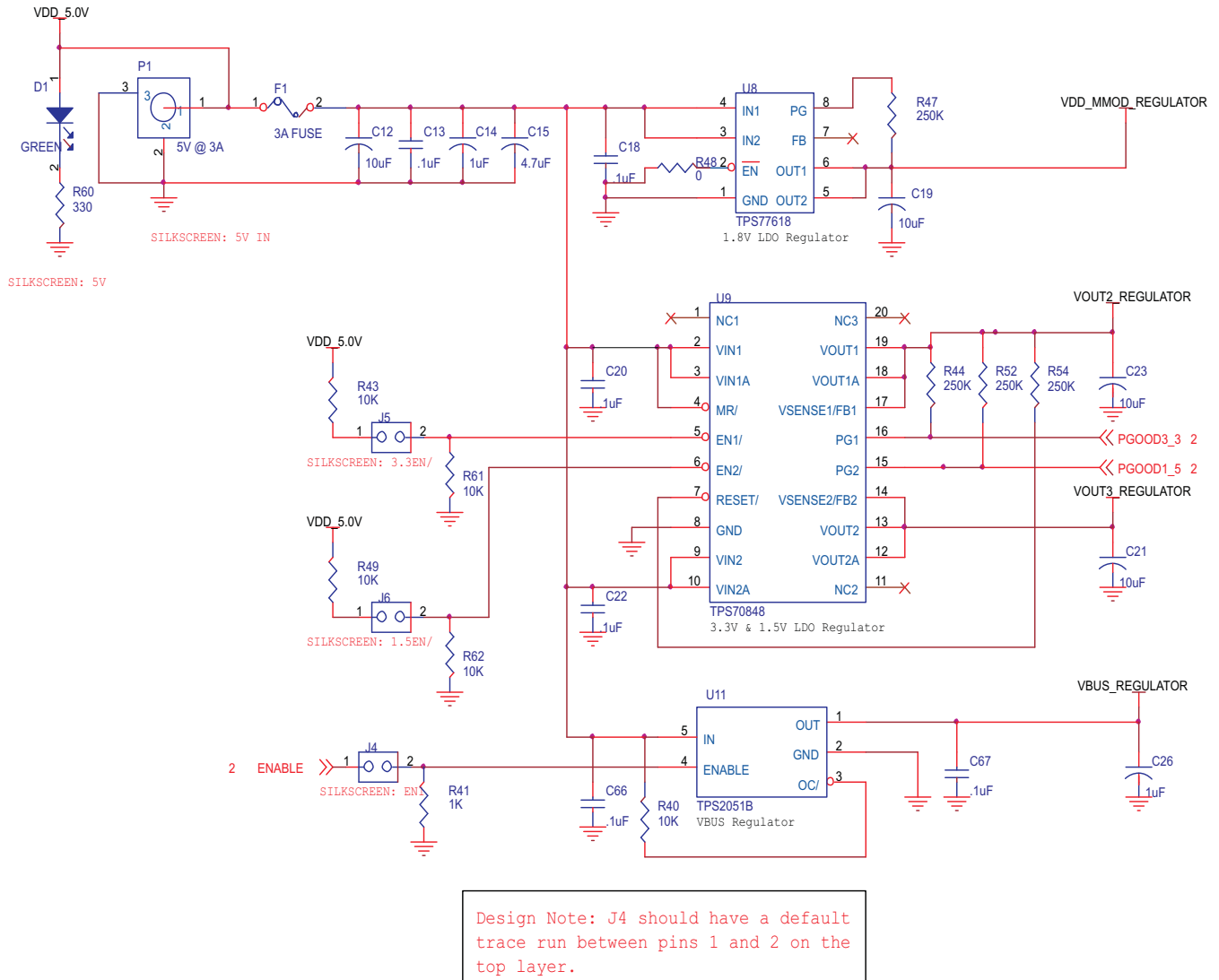

Figure 1-6. Voltage Regulators

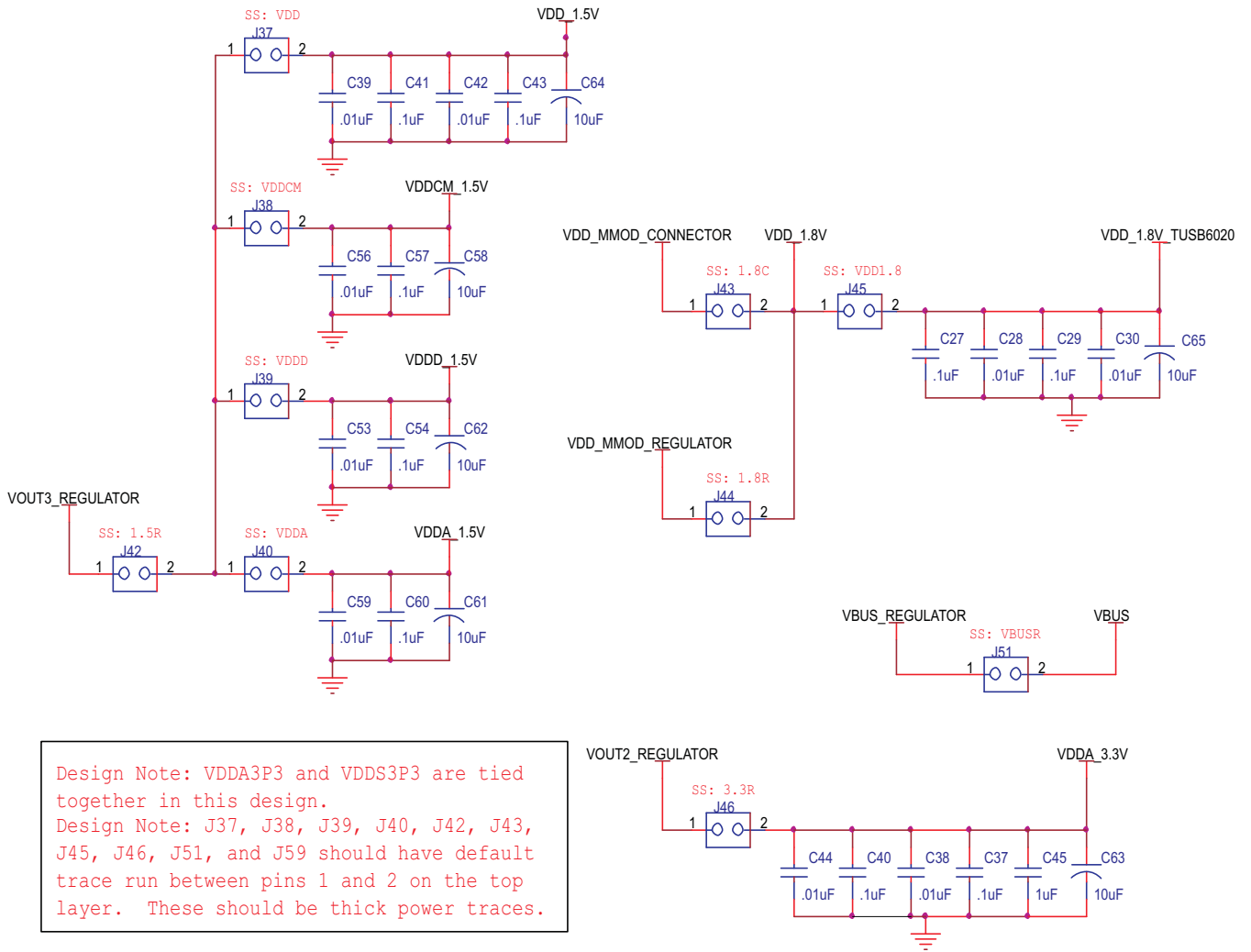

Figure 1-7. Power Jumpers

Design Note: GPIO7 must always be pulled low, directly to ground, for the TUSB6020 to operate properly. GPIO6 can be pulled low to select the XI input, otherwise the TUSB6020 will select the CLKIN as the clock source.

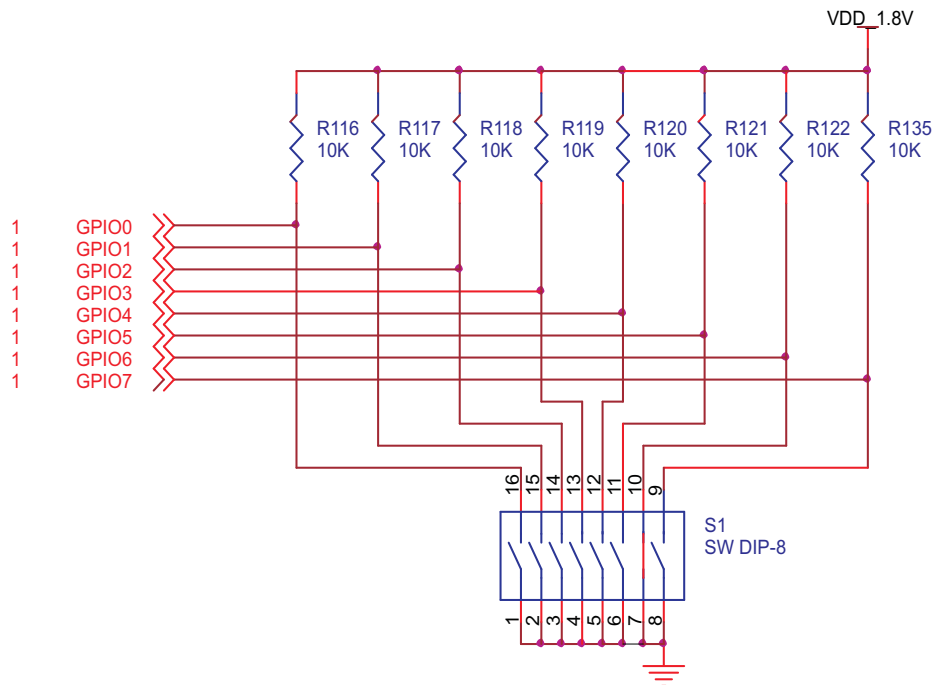

Figure 1-8. GPIO Switches

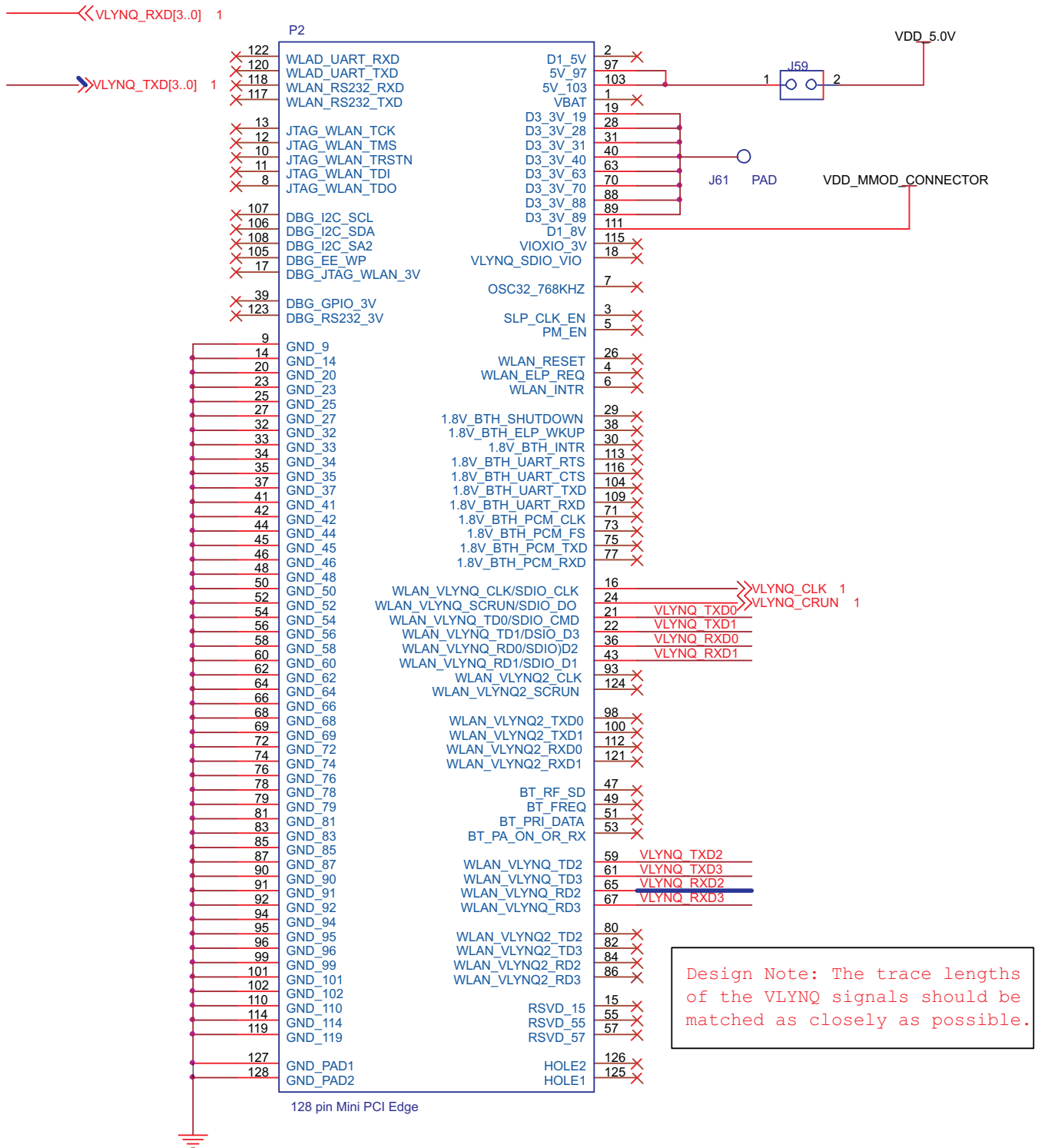

Figure 1-9. Mini PCI Connector

EVALUATION BOARD/KIT IMPORTANT NOTICE

Texas Instruments (TI) provides the enclosed product(s) under the following conditions:

This evaluation board/kit is intended for use for **ENGINEERING DEVELOPMENT, DEMONSTRATION, OR EVALUATION PURPOSES ONLY** and is not considered by TI to be a finished end-product fit for general consumer use. Persons handling the product(s) must have electronics training and observe good engineering practice standards. As such, the goods being provided are not intended to be complete in terms of required design-, marketing-, and/or manufacturing-related protective considerations, including product safety and environmental measures typically found in end products that incorporate such semiconductor components or circuit boards. This evaluation board/kit does not fall within the scope of the European Union directives regarding electromagnetic compatibility, restricted substances (RoHS), recycling (WEEE), FCC, CE or UL, and therefore may not meet the technical requirements of these directives or other related directives.

Should this evaluation board/kit not meet the specifications indicated in the User's Guide, the board/kit may be returned within 30 days from the date of delivery for a full refund. **THE FOREGOING WARRANTY IS THE EXCLUSIVE WARRANTY MADE BY SELLER TO BUYER AND IS IN LIEU OF ALL OTHER WARRANTIES, EXPRESSED, IMPLIED, OR STATUTORY, INCLUDING ANY WARRANTY OF MERCHANTABILITY OR FITNESS FOR ANY PARTICULAR PURPOSE.**

The user assumes all responsibility and liability for proper and safe handling of the goods. Further, the user indemnifies TI from all claims arising from the handling or use of the goods. Due to the open construction of the product, it is the user's responsibility to take any and all appropriate precautions with regard to electrostatic discharge.

EXCEPT TO THE EXTENT OF THE INDEMNITY SET FORTH ABOVE, NEITHER PARTY SHALL BE LIABLE TO THE OTHER FOR ANY INDIRECT, SPECIAL, INCIDENTAL, OR CONSEQUENTIAL DAMAGES.

TI currently deals with a variety of customers for products, and therefore our arrangement with the user **is not exclusive.**

TI assumes **no liability for applications assistance, customer product design, software performance, or infringement of patents or services described herein.**

Please read the User's Guide and, specifically, the Warnings and Restrictions notice in the User's Guide prior to handling the product. This notice contains important safety information about temperatures and voltages. For additional information on TI's environmental and/or safety programs, please contact the TI application engineer or visit www.ti.com/esh.

No license is granted under any patent right or other intellectual property right of TI covering or relating to any machine, process, or combination in which such TI products or services might be or are used.

FCC Warning

This evaluation board/kit is intended for use for **ENGINEERING DEVELOPMENT, DEMONSTRATION, OR EVALUATION PURPOSES ONLY** and is not considered by TI to be a finished end-product fit for general consumer use. It generates, uses, and can radiate radio frequency energy and has not been tested for compliance with the limits of computing devices pursuant to part 15 of FCC rules, which are designed to provide reasonable protection against radio frequency interference. Operation of this equipment in other environments may cause interference with radio communications, in which case the user at his own expense will be required to take whatever measures may be required to correct this interference.

EVM WARNINGS AND RESTRICTIONS

It is important to operate this EVM within the input voltage range of 5 VDC and the output voltage range of 5 VDC.

Exceeding the specified input range may cause unexpected operation and/or irreversible damage to the EVM. If there are questions concerning the input range, please contact a TI field representative prior to connecting the input power.

Applying loads outside of the specified output range may result in unintended operation and/or possible permanent damage to the EVM. Please consult the EVM User's Guide prior to connecting any load to the EVM output. If there is uncertainty as to the load specification, please contact a TI field representative.

During normal operation, some circuit components may have case temperatures greater than . The EVM is designed to operate properly with certain components above as long as the input and output ranges are maintained. These components include but are not limited to linear regulators, switching transistors, pass transistors, and current sense resistors. These types of devices can be identified using the EVM schematic located in the EVM User's Guide. When placing measurement probes near these devices during operation, please be aware that these devices may be very warm to the touch.

Mailing Address: Texas Instruments, Post Office Box 655303, Dallas, Texas 75265
Copyright = 2008, Texas Instruments Incorporated

IMPORTANT NOTICE

Texas Instruments Incorporated and its subsidiaries (TI) reserve the right to make corrections, modifications, enhancements, improvements, and other changes to its products and services at any time and to discontinue any product or service without notice. Customers should obtain the latest relevant information before placing orders and should verify that such information is current and complete. All products are sold subject to TI's terms and conditions of sale supplied at the time of order acknowledgment.

TI warrants performance of its hardware products to the specifications applicable at the time of sale in accordance with TI's standard warranty. Testing and other quality control techniques are used to the extent TI deems necessary to support this warranty. Except where mandated by government requirements, testing of all parameters of each product is not necessarily performed.

TI assumes no liability for applications assistance or customer product design. Customers are responsible for their products and applications using TI components. To minimize the risks associated with customer products and applications, customers should provide adequate design and operating safeguards.

TI does not warrant or represent that any license, either express or implied, is granted under any TI patent right, copyright, mask work right, or other TI intellectual property right relating to any combination, machine, or process in which TI products or services are used. Information published by TI regarding third-party products or services does not constitute a license from TI to use such products or services or a warranty or endorsement thereof. Use of such information may require a license from a third party under the patents or other intellectual property of the third party, or a license from TI under the patents or other intellectual property of TI.

Reproduction of TI information in TI data books or data sheets is permissible only if reproduction is without alteration and is accompanied by all associated warranties, conditions, limitations, and notices. Reproduction of this information with alteration is an unfair and deceptive business practice. TI is not responsible or liable for such altered documentation. Information of third parties may be subject to additional restrictions.

Resale of TI products or services with statements different from or beyond the parameters stated by TI for that product or service voids all express and any implied warranties for the associated TI product or service and is an unfair and deceptive business practice. TI is not responsible or liable for any such statements.

TI products are not authorized for use in safety-critical applications (such as life support) where a failure of the TI product would reasonably be expected to cause severe personal injury or death, unless officers of the parties have executed an agreement specifically governing such use. Buyers represent that they have all necessary expertise in the safety and regulatory ramifications of their applications, and acknowledge and agree that they are solely responsible for all legal, regulatory and safety-related requirements concerning their products and any use of TI products in such safety-critical applications, notwithstanding any applications-related information or support that may be provided by TI. Further, Buyers must fully indemnify TI and its representatives against any damages arising out of the use of TI products in such safety-critical applications.

TI products are neither designed nor intended for use in military/aerospace applications or environments unless the TI products are specifically designated by TI as military-grade or "enhanced plastic." Only products designated by TI as military-grade meet military specifications. Buyers acknowledge and agree that any such use of TI products which TI has not designated as military-grade is solely at the Buyer's risk, and that they are solely responsible for compliance with all legal and regulatory requirements in connection with such use.

TI products are neither designed nor intended for use in automotive applications or environments unless the specific TI products are designated by TI as compliant with ISO/TS 16949 requirements. Buyers acknowledge and agree that, if they use any non-designated products in automotive applications, TI will not be responsible for any failure to meet such requirements.

Following are URLs where you can obtain information on other Texas Instruments products and application solutions:

Products

Amplifiers	amplifier.ti.com
Data Converters	dataconverter.ti.com
DSP	dsp.ti.com
Clocks and Timers	www.ti.com/clocks
Interface	interface.ti.com
Logic	logic.ti.com
Power Mgmt	power.ti.com
Microcontrollers	microcontroller.ti.com
RFID	www.ti-rfid.com
RF/IF and ZigBee® Solutions	www.ti.com/lprf

Applications

Audio	www.ti.com/audio
Automotive	www.ti.com/automotive
Broadband	www.ti.com/broadband
Digital Control	www.ti.com/digitalcontrol
Medical	www.ti.com/medical
Military	www.ti.com/military
Optical Networking	www.ti.com/opticalnetwork
Security	www.ti.com/security
Telephony	www.ti.com/telephony
Video & Imaging	www.ti.com/video
Wireless	www.ti.com/wireless

Mailing Address: Texas Instruments, Post Office Box 655303, Dallas, Texas 75265
Copyright © 2008, Texas Instruments Incorporated

Looking for pricing, stock, or lifecycle information?

Click below to explore more details on WIN SOURCE:

 [View TUSB6020PFC](#) on WIN SOURCE

 [Texas Instruments](#) Information

Optimize Your Supply Chain with WIN SOURCE Solutions

-  Global Sourcing Solution
-  Obsolete Management
-  Cost Control Management
-  Shortage Management
-  Alternative Solution
-  Excess Inventory Management