



THE DATASHEET OF TUSB501DRFR



USB 3.0 Single Channel Redriver with Equalization

Check for Samples: [TUSB501](#)

FEATURES

- **Aggressive Low-Power Architecture (Typ):**
 - 126 mW Active Power
 - 20 mW in U2/U3
 - 3 mW with No Connection
- **Automatic LFPS DE Control**
- **Excellent Jitter and Loss Compensation**
 - 32 inches of FR4 4 mil Stripline
 - 3 m of 30 AWG cable
- **Integrated Termination**
- **Small 2 x 2 mm QFN Package**
- **Selectable Receiver Equalization, Transmitter De-Emphasis and Output Swing**
- **Hot-Plug Capable**
- **ESD Protection ± 5 kV HBM**

APPLICATIONS

- **Cell Phones, Computers, Docking Stations, TVs, Active Cables, Backplanes**

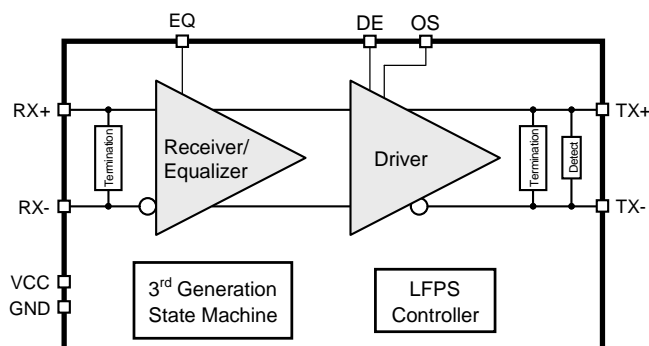

DESCRIPTION

The TUSB501 is a 3rd generation 3.3-V USB 3.0 single-channel redriver. When 5 Gbps SuperSpeed USB signals travel across a PCB or cable, signal integrity degrades due to loss and inter-symbol interference. The TUSB501 recovers incoming data by applying equalization that compensates channel loss, and drives out signals with a high differential voltage. This extends the possible channel length, and enables systems to pass USB 3.0 compliance. The TUSB501 advanced state machine makes it transparent to hosts and devices.

After power up, the TUSB501 periodically performs receiver detection on the TX pair. If it detects a SuperSpeed USB receiver, RX termination becomes enabled, and the TUSB501 is ready to redrive.

The receiver equalizer has three gain settings that are controlled by pin EQ: 3 dB, 6 dB, and 9 dB. This should be set based on amount of loss before the TUSB501. Likewise, the output driver supports configuration of De-Emphasis and Output Swing (pins DE and OS). These settings allow the TUSB501 to be flexibly placed in the SuperSpeed USB path, with optimal performance.

Over previous generations, the TUSB501 features reduced power in all link states, a stronger OS option, improved receiver equalization settings, and an intelligent LFPS Controller. This controller senses the low frequency signals and automatically disables driver de-emphasis, for full USB 3.0 compliance.

The TUSB501 is packaged in a small 2 x 2 mm QFN, and operates through an industrial temperature range of -40°C to 85°C .



Please be aware that an important notice concerning availability, standard warranty, and use in critical applications of Texas Instruments semiconductor products and disclaimers thereto appears at the end of this data sheet.

All trademarks are the property of their respective owners.



These devices have limited built-in ESD protection. The leads should be shorted together or the device placed in conductive foam during storage or handling to prevent electrostatic damage to the MOS gates.

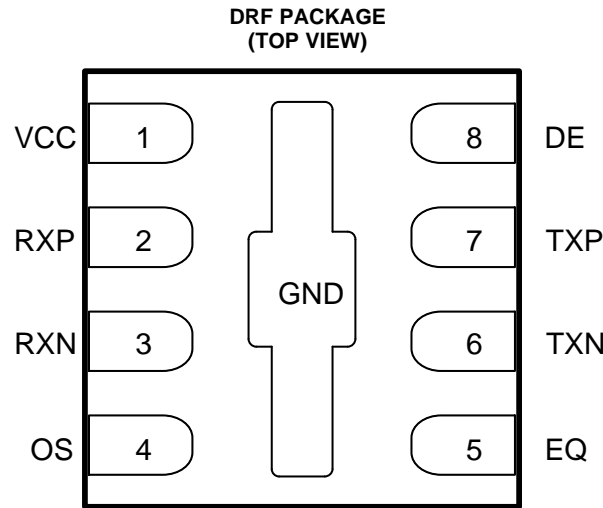

PIN FUNCTIONS

PIN		TYPE	DESCRIPTION
NAME	NO.		
RXP	2	Differential I/O	Differential input pair for 5 Gbps SuperSpeed USB signals.
RXN	3		
TXN	6		Differential output pair for 5 Gbps SuperSpeed USB signals.
TXP	7		
EQ	5	CMOS Input	Sets the receiver equalizer gain. 3-state input with integrated pull-up and pull-down resistors.
DE	8		Sets the output de-emphasis gain. 3-state input with integrated pull-up and pull-down resistors.
OS	4		Sets the output swing (differential voltage amplitude). 2-state input with an integrated pull-down resistor.
VCC	1	Power	3.3-V power supply
GND	Thermal Pad		Reference ground

DEVICE CONFIGURATION

Table 1. Control Pin Effects (Typical Values)

PIN	DESCRIPTION	LOGIC STATE	GAIN
EQ	Equalization Amount	Low	3 dB
		Floating	6 dB
		High	9 dB

PIN	DESCRIPTION	LOGIC STATE	OUTPUT DIFFERENTIAL VOLTAGE FOR THE TRANSITION BIT
OS	Output Swing Amplitude	Low	930 mV _{pp}
		High	1300 mV _{pp}

PIN	DESCRIPTION	LOGIC STATE	DE-EMPHASIS RATIO	
			FOR OS = LOW	FOR OS = HIGH
DE	De-Emphasis Amount	Low	0 dB	-2.6 dB
		Floating	-3.5 dB	-5.9 dB
		High	-6.2 dB	-8.3 dB

(1) Typical values

ABSOLUTE MAXIMUM RATINGS

 over operating free-air temperature range (unless otherwise noted) ⁽¹⁾

		MIN	MAX	UNIT
Supply voltage range ⁽²⁾	V _{CC}	-0.5	4	V
Voltage range at any input or output terminal	Differential I/O	-0.5	4	V
	CMOS inputs	-0.5	V _{CC} + 0.5	V
Electrostatic discharge	Human body model (all pins) ⁽³⁾		±5	kV
	Charged-device model (all pins) ⁽⁴⁾		±1.5	
Storage temperature, T _{STG}		-65	150	°C
Maximum junction temperature, T _J		-40	105	°C

- (1) Stresses beyond those listed under absolute maximum ratings may cause permanent damage to the device. These are stress ratings only and functional operation of the device at these or any conditions beyond those indicated under recommended operating conditions is not implied. Exposure to absolute-maximum-rated conditions for extended periods may affect device reliability.
- (2) All voltage values are with respect to the GND terminals.
- (3) Tested in accordance with JEDEC Standard 22, Test Method A114-B.
- (4) Tested in accordance with JEDEC Standard 22, Test Method C101-A.

THERMAL INFORMATION

THERMAL METRIC ⁽¹⁾		TUSB501	UNITS
		DRF	
θ _{JA}	Junction-to-ambient thermal resistance	102.4	°C/W
θ _{JC(top)}	Junction-to-case(top) thermal resistance	90.3	
θ _{JB}	Junction-to-board thermal resistance	21.2	
ψ _{JT}	Junction-to-top characterization parameter	70	
ψ _{JB}	Junction-to-board characterization parameter	3.6	
θ _{JC(bottom)}	Junction-to-case(bottom) thermal resistance	70.2	

- (1) For more information about traditional and new thermal metrics, see the IC Package Thermal Metrics application report, [SPRA953](#).

RECOMMENDED OPERATING CONDITIONS

over operating free-air temperature range (unless otherwise noted)

		MIN	NOM	MAX	UNIT
V _{CC}	Main power supply	3	3.3	3.6	V
T _A	Operating free-air temperature	-40		85	°C
C _{AC}	AC coupling capacitor	75	100	200	nF

POWER SUPPLY CHARACTERISTICS

over operating free-air temperature range (unless otherwise noted)

PARAMETER		TEST CONDITIONS	MIN	TYP ⁽¹⁾	MAX ⁽²⁾	UNIT
I _{CC-ACTIVE}	Average active current	Link in U0 with SuperSpeed USB data transmission, OS = Low		38.1		mA
		Link in U0 with SuperSpeed USB data transmission, OS = High		43.8	65	
I _{CC-IDLE}	Average current in idle state	Link has some activity, not in U0, OS = Low		29.8		mA
I _{CC-U2U3}	Average current in U2/U3	Link in U2 or U3		6.1		mA
I _{CC-NC}	Average current with no connection	No SuperSpeed USB device is connected to TXP, TXN		1.3		mA
P _D	Power Dissipation in U0	OS = Low		126		mW
		OS = High		145	234	

(1) TYP values use V_{CC} = 3.3 V, T_A = 25°C.

(2) MAX values use V_{CC} = 3.6 V, T_A = -40°C.

DC ELECTRICAL CHARACTERISTICS

over operating free-air temperature range (unless otherwise noted)

PARAMETER		TEST CONDITIONS	MIN	TYP	MAX	UNIT
3-State CMOS Inputs (EQ, DE)						
V _{IH}	High-level input voltage		2.8			V
V _{IM}	Mid-level input voltage			V _{CC} / 2		V
V _{IL}	Low-level input voltage				0.6	V
V _F	Floating voltage	V _{IN} = High impedance		V _{CC} / 2		V
R _{PU}	Internal pull-up resistance			190		kΩ
R _{PD}	Internal pull-down resistance			190		kΩ
I _{IH}	High-level input current	V _{IN} = 3.6 V			36	μA
I _{IL}	Low-level input current	V _{IN} = GND, V _{CC} = 3.6 V	-36			μA
2-State CMOS Input (OS)						
V _{IH}	High-level input voltage		2			V
V _{IL}	Low-level input voltage				0.5	V
V _F	Floating voltage	V _{IN} = High impedance		GND		V
R _{PD}	Internal pull-down resistance			270		kΩ
I _{IH}	High-level input current	V _{IN} = 3.6 V			26	μA
I _{IL}	Low-level input current	V _{IN} = GND	-1			μA

AC ELECTRICAL CHARACTERISTICS

over operating free-air temperature range (unless otherwise noted)

PARAMETER		TEST CONDITIONS	MIN	TYP	MAX	UNIT
Differential Receiver (RXP, RXN)						
$V_{DIFF-pp}$	Input differential voltage swing	AC-coupled differential peak-to-peak signal	100		1200	mV _{pp}
V_{CM-RX}	Common-mode voltage bias in the receiver (DC)			3.3		V
$Z_{RX-DIFF}$	Differential input impedance (DC)	Present after a SuperSpeed USB device is detected on TXP/TXN	72	91	120	Ω
Z_{RX-CM}	Common-mode input impedance (DC)	Present after a SuperSpeed USB device is detected on TXP, TXN	18	22.8	30	Ω
$Z_{RX-HIGH-IMP-DC-POS}$	Common-mode input impedance with termination disabled (DC)	Present when no SuperSpeed USB device is detected on TXP, TXN. Measured over the range of 0-500 mV with respect to GND.	25	35		k Ω
$V_{RX-LFPS-DET-DIFF-pp}$	Low Frequency Periodic Signaling (LFPS) Detect Threshold	Below the minimum is squelched	100		300	mV _{pp}
Differential Transmitter (TXP, TXN)						
$V_{TX-DIFF-PP}$	Transmitter differential voltage swing (transition-bit)	OS = Low, No load		930		mV _{pp}
		OS = High, No load		1300		
$V_{TX-DE-RATIO}$	Transmitter de-emphasis	DE = Floating, OS = Low		-3.5		dB
C_{TX}	TX input capacitance to GND	At 2.5 GHz		1.25		pF
$Z_{TX-DIFF}$	Differential impedance of the driver		75	93	125	Ω
Z_{TX-CM}	Common-mode impedance of the driver	Measured with respect to AC ground over 0-500 mV	18.75		31.25	Ω
I_{TX-SC}	TX short circuit current	TX \pm shorted to GND			60	mA
V_{CM-TX}	Common-mode voltage bias in the transmitter (DC)		1.2		2.5	V
$V_{CM-TX-AC}$	AC common-mode voltage swing in active mode	Within U0 and within LFPS			100	mV _{pp}
$V_{TX-IDLE-DIFF-AC-pp}$	Differential voltage swing during electrical idle	Tested with a high-pass filter	0		10	mV _{pp}
$V_{TX-CM-DeltaU1-U0}$	Absolute delta of DC CM voltage during active and idle states	Restrict the test condition to meet 100 mV			100	mV
$V_{TX-idle-diff-DC}$	DC electrical idle differential output voltage	Voltage must be low pass filtered to remove any AC component	0		12	mV
Differential Transmitter (TXP, TXN)						
t_R, t_F	Output rise, fall time see Figure 4	20%-80% of differential voltage measured 1 inch from the output pin		80		ps
t_{RF-MM}	Output Rise, Fall time mismatch	20%-80% of differential voltage measured 1 inch from the output pin			20	ps
$t_{diff-LH}, t_{diff-HL}$	Differential propagation delay see Figure 2	De-emphasis = -3.5 dB propagation delay between 50% level at input and output		290		ps
$t_{idleEntry}, t_{idleExit}$	Idle entry and exit times see Figure 3			3.6		ns

AC ELECTRICAL CHARACTERISTICS (continued)

over operating free-air temperature range (unless otherwise noted)

PARAMETER	TEST CONDITIONS	MIN	TYP	MAX	UNIT
Timing					
t_{READY}	Time from power applied until RX termination	Apply 0 V to VCC, connect SuperSpeed USB termination to TX±, apply 3.3 V to VCC, and measure when Z _{RX-DIFF} is enabled.		9	ms
Jitter					
$T_{\text{JTX-EYE}}$	Total jitter ⁽¹⁾ ⁽²⁾	EQ = Floating, OS = High, DE = High		0.213	UI ⁽³⁾
D_{JTX}	Deterministic jitter ⁽²⁾	See Figure 1.		0.197	UI ⁽³⁾
R_{JTX}	Random jitter ⁽²⁾ ⁽⁴⁾			0.016	UI ⁽³⁾

- (1) Includes R_J at 10⁻¹².
- (2) Measured at the ends of reference channel in Figure 1 with K28.5 pattern, V_{ID} = 1000 mV_{pp}, 5 Gbps, -3.5 dB de-emphasis from source.
- (3) UI = 200 ps.
- (4) R_J calculated as 14.069 times the RMS random jitter for 10⁻¹² BER.

PARAMETER MEASUREMENT INFORMATION

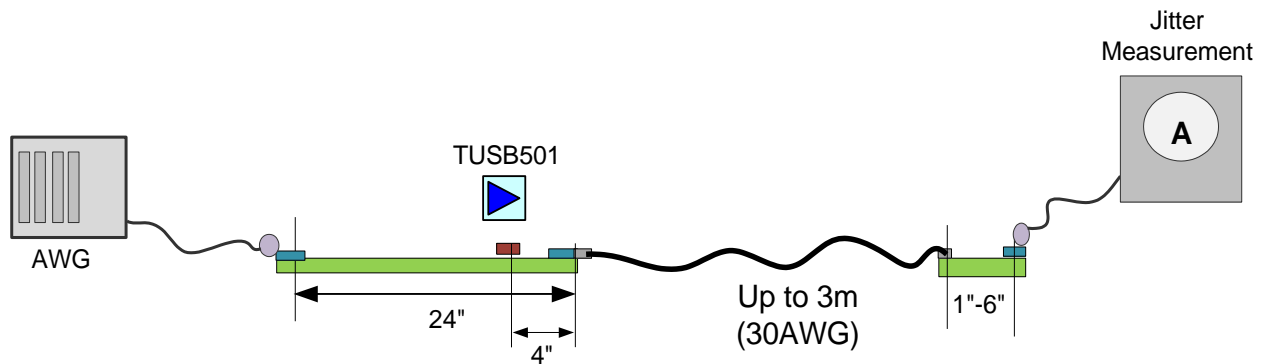

Figure 1. Jitter Measurement Setup

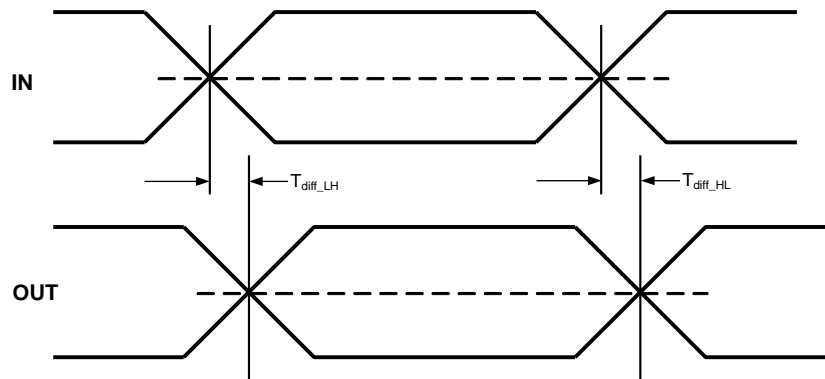

Figure 2. Propagation Delay

PARAMETER MEASUREMENT INFORMATION (continued)

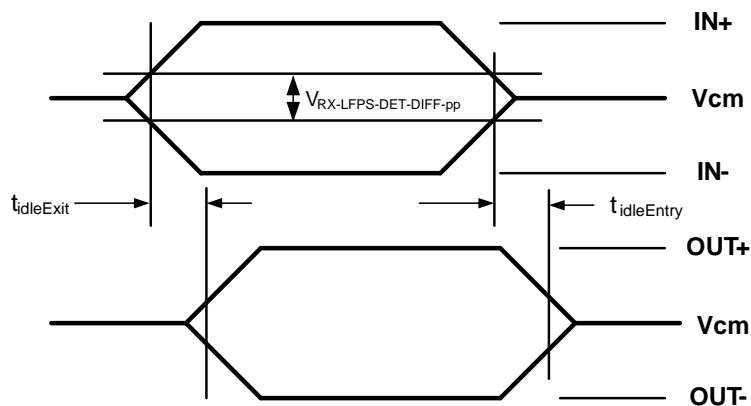

Figure 3. Electrical Idle Mode Exit and Entry Delay

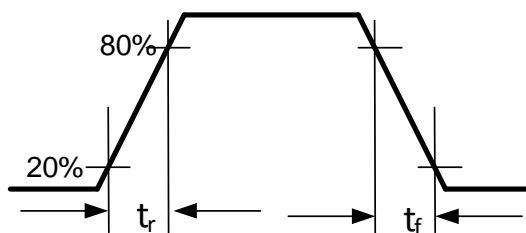

Figure 4. Output Rise and Fall Times

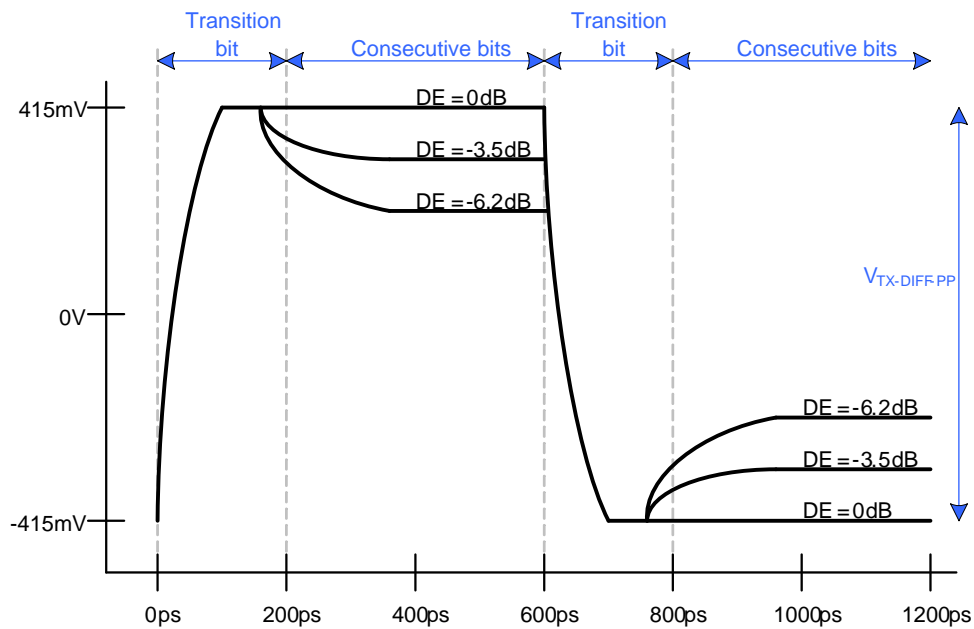

Figure 5. Transmitter Differential Voltage, OS = L

PARAMETER MEASUREMENT INFORMATION (continued)

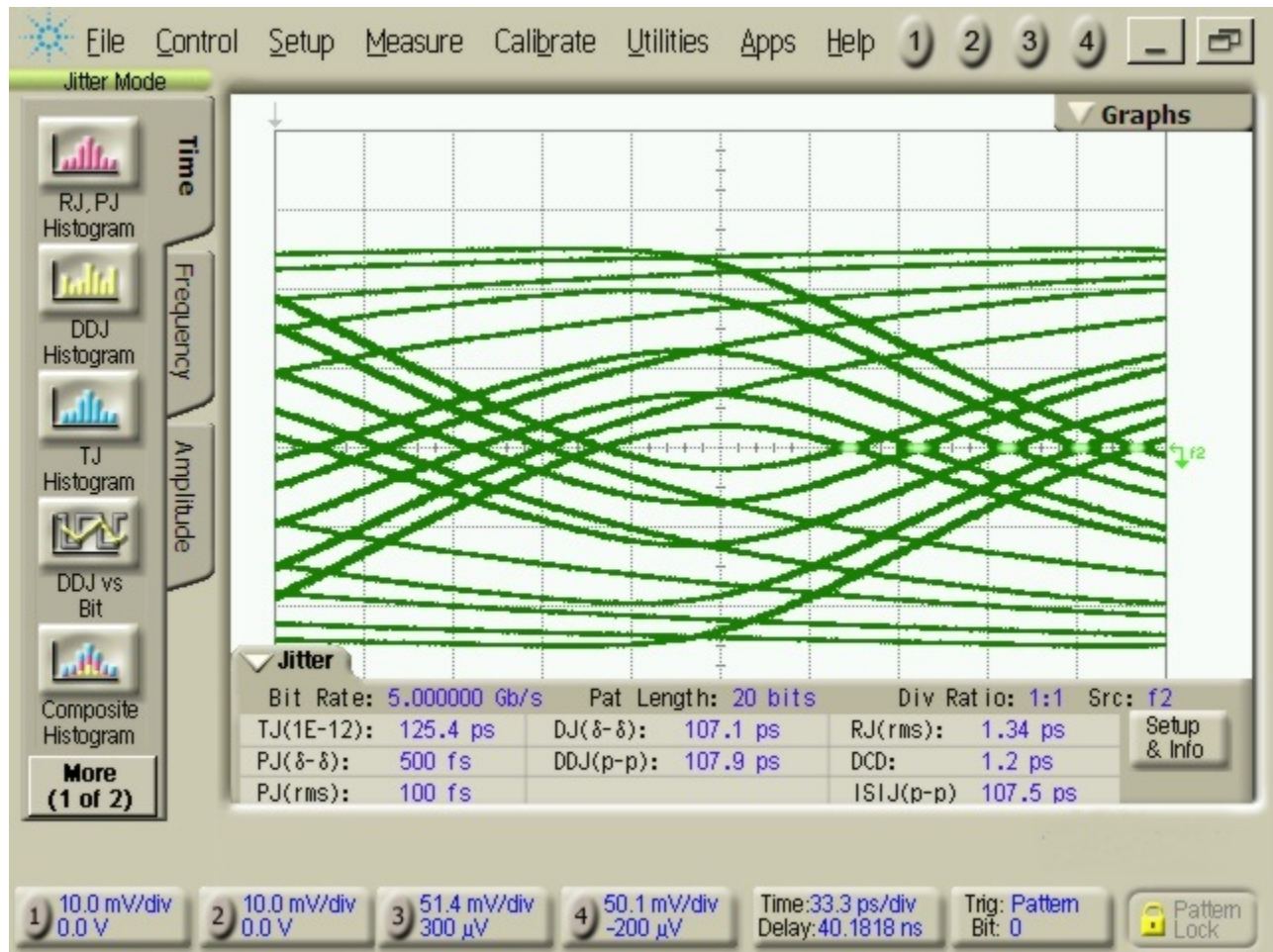

Figure 6. Input for Typical Output Measurement at TUSB501 at $T_A = 25^\circ\text{C}$

PARAMETER MEASUREMENT INFORMATION (continued)

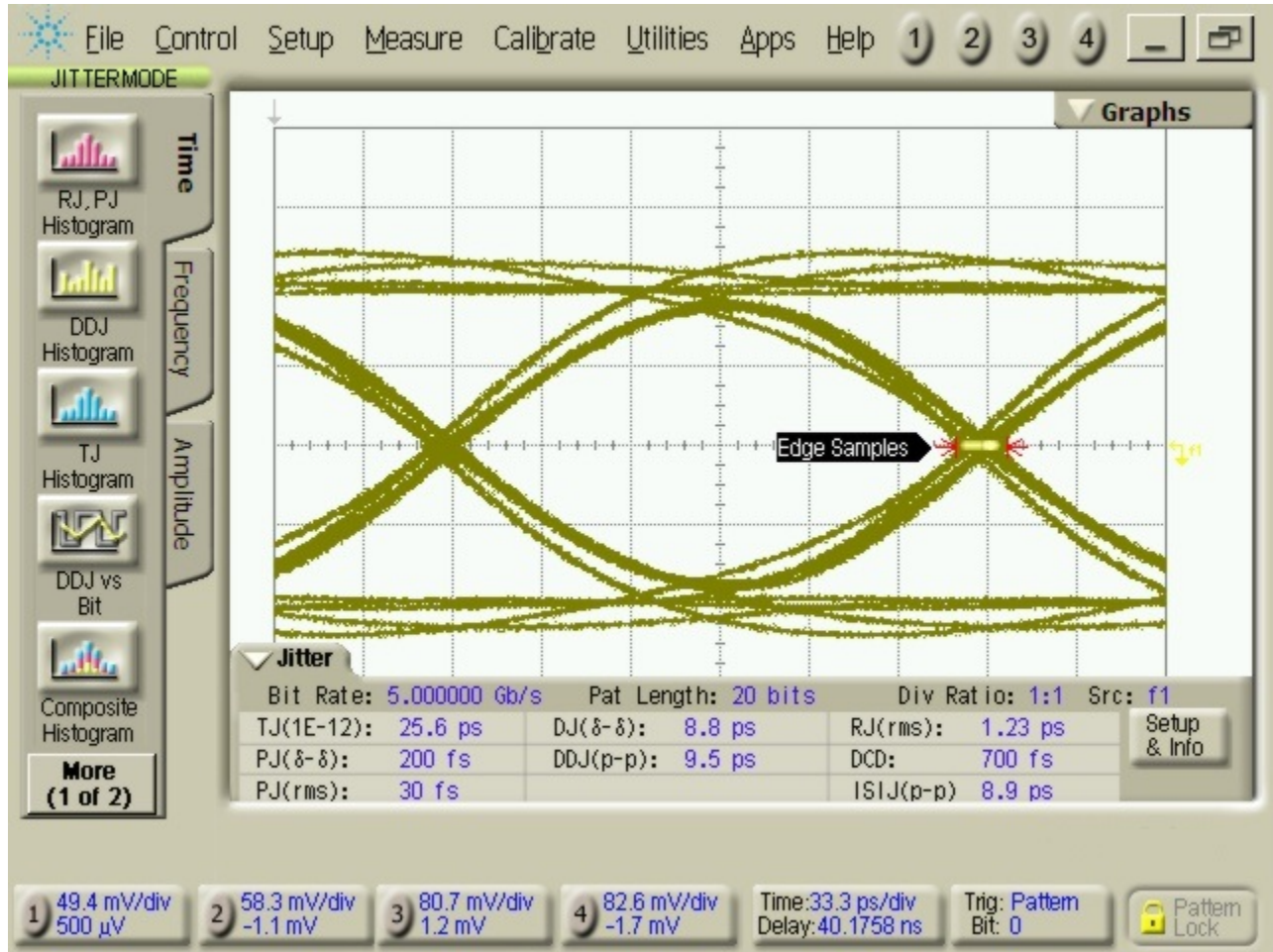

Figure 7. Typical Output Eye for Jitter Measurement Setup in Figure 1 at $T_A = 25^\circ\text{C}$, DE = HIGH, OS = HIGH, EQ = NC

REVISION HISTORY

Changes from Original (August 2013) to Revision A	Page
• Changed from Product Preview to Production Data	1

PACKAGING INFORMATION

Orderable Device	Status (1)	Package Type	Package Drawing	Pins	Package Qty	Eco Plan (2)	Lead finish/ Ball material (6)	MSL Peak Temp (3)	Op Temp (°C)	Device Marking (4/5)	Samples
TUSB501DRFR	ACTIVE	WSON	DRF	8	3000	RoHS & Green	NIPDAU	Level-2-260C-1 YEAR	-40 to 85	T501	Samples

(1) The marketing status values are defined as follows:

ACTIVE: Product device recommended for new designs.

LIFEBUY: TI has announced that the device will be discontinued, and a lifetime-buy period is in effect.

NRND: Not recommended for new designs. Device is in production to support existing customers, but TI does not recommend using this part in a new design.

PREVIEW: Device has been announced but is not in production. Samples may or may not be available.

OBSELETE: TI has discontinued the production of the device.

(2) **RoHS:** TI defines "RoHS" to mean semiconductor products that are compliant with the current EU RoHS requirements for all 10 RoHS substances, including the requirement that RoHS substance do not exceed 0.1% by weight in homogeneous materials. Where designed to be soldered at high temperatures, "RoHS" products are suitable for use in specified lead-free processes. TI may reference these types of products as "Pb-Free".

RoHS Exempt: TI defines "RoHS Exempt" to mean products that contain lead but are compliant with EU RoHS pursuant to a specific EU RoHS exemption.

Green: TI defines "Green" to mean the content of Chlorine (Cl) and Bromine (Br) based flame retardants meet JS709B low halogen requirements of <=1000ppm threshold. Antimony trioxide based flame retardants must also meet the <=1000ppm threshold requirement.

(3) MSL, Peak Temp. - The Moisture Sensitivity Level rating according to the JEDEC industry standard classifications, and peak solder temperature.

(4) There may be additional marking, which relates to the logo, the lot trace code information, or the environmental category on the device.

(5) Multiple Device Markings will be inside parentheses. Only one Device Marking contained in parentheses and separated by a "-" will appear on a device. If a line is indented then it is a continuation of the previous line and the two combined represent the entire Device Marking for that device.

(6) Lead finish/Ball material - Orderable Devices may have multiple material finish options. Finish options are separated by a vertical ruled line. Lead finish/Ball material values may wrap to two lines if the finish value exceeds the maximum column width.

Important Information and Disclaimer:The information provided on this page represents TI's knowledge and belief as of the date that it is provided. TI bases its knowledge and belief on information provided by third parties, and makes no representation or warranty as to the accuracy of such information. Efforts are underway to better integrate information from third parties. TI has taken and continues to take reasonable steps to provide representative and accurate information but may not have conducted destructive testing or chemical analysis on incoming materials and chemicals. TI and TI suppliers consider certain information to be proprietary, and thus CAS numbers and other limited information may not be available for release.

In no event shall TI's liability arising out of such information exceed the total purchase price of the TI part(s) at issue in this document sold by TI to Customer on an annual basis.

OTHER QUALIFIED VERSIONS OF TUSB501 :

- Automotive: [TUSB501-Q1](#)

NOTE: Qualified Version Definitions:

- Automotive - Q100 devices qualified for high-reliability automotive applications targeting zero defects

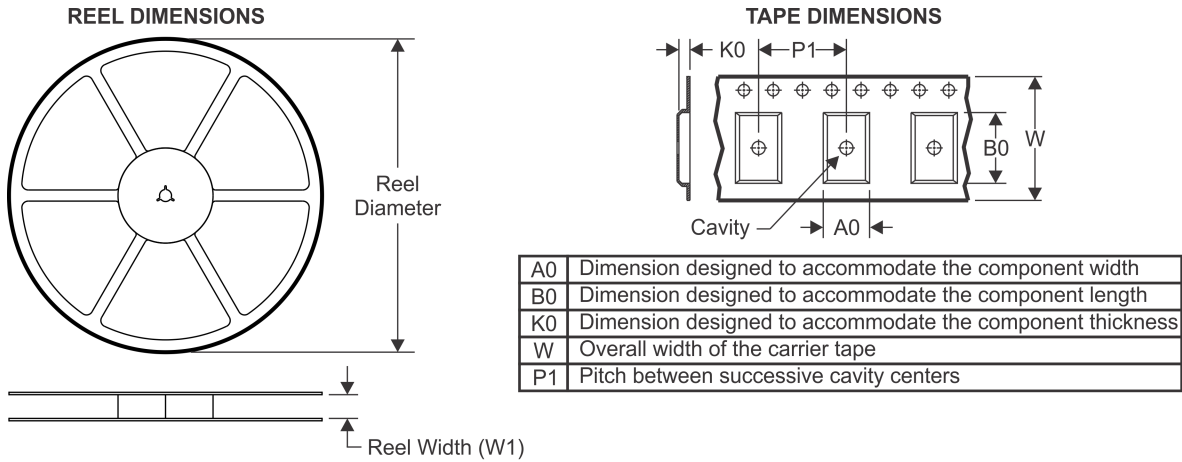
TAPE AND REEL INFORMATION

QUADRANT ASSIGNMENTS FOR PIN 1 ORIENTATION IN TAPE

*All dimensions are nominal

Device	Package Type	Package Drawing	Pins	SPQ	Reel Diameter (mm)	Reel Width W1 (mm)	A0 (mm)	B0 (mm)	K0 (mm)	P1 (mm)	W (mm)	Pin1 Quadrant
TUSB501DRFR	WSON	DRF	8	3000	180.0	8.4	2.3	2.3	1.15	4.0	8.0	Q2

TAPE AND REEL BOX DIMENSIONS





*All dimensions are nominal

Device	Package Type	Package Drawing	Pins	SPQ	Length (mm)	Width (mm)	Height (mm)
TUSB501DRFR	WSON	DRF	8	3000	210.0	185.0	35.0

DRF (S-PWSON-N8)

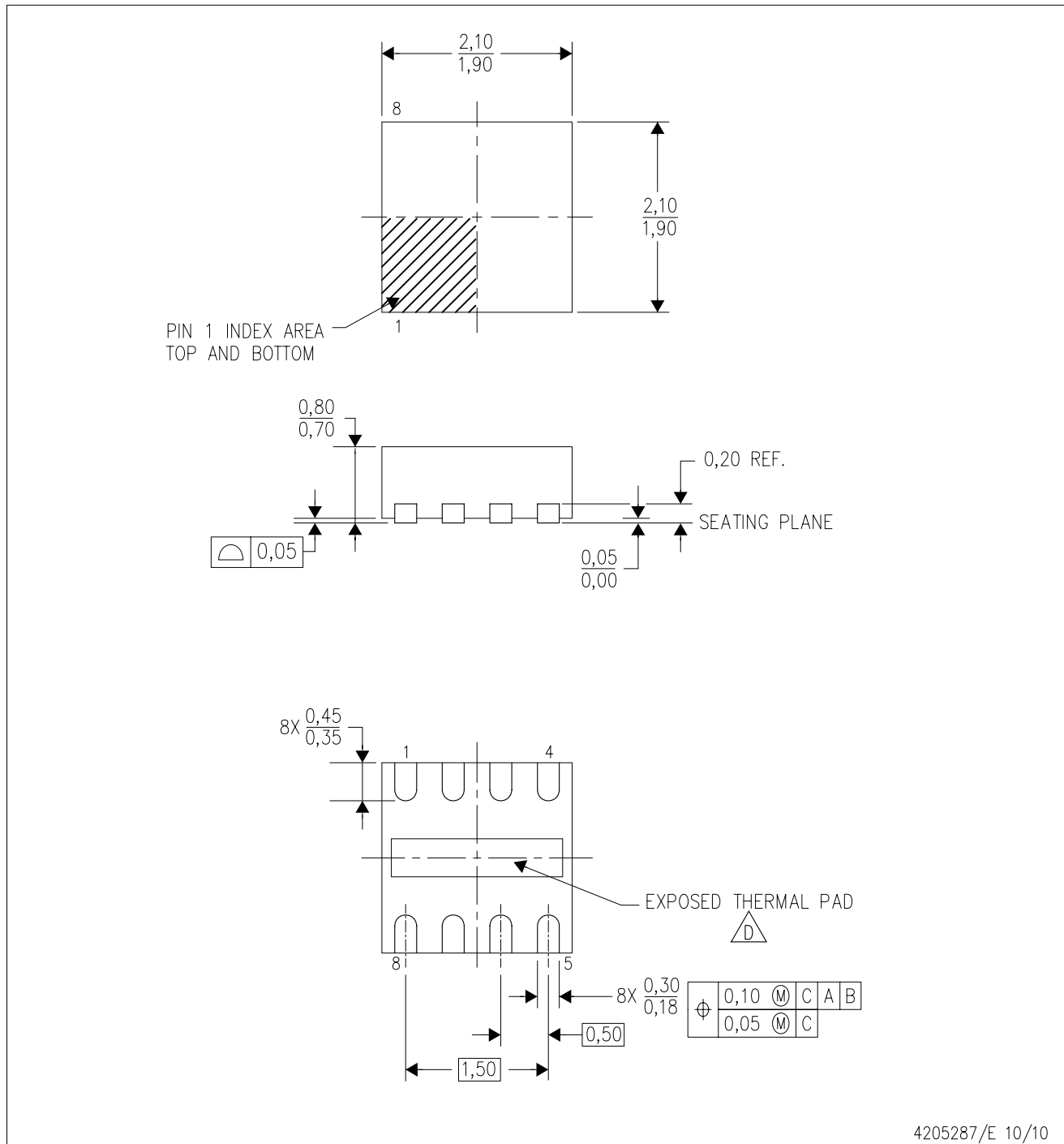
PLASTIC SMALL OUTLINE NO-LEAD



- NOTES:
- A. All linear dimensions are in millimeters. Dimensioning and tolerancing per ASME Y14.5M-1994.
 - B. This drawing is subject to change without notice.
 - C. Quad Flatpack, No-Leads (QFN) package configuration.
 -  D. The Package thermal pad must be soldered to the board for thermal and mechanical performance. See product data sheet for details regarding the exposed thermal pad dimensions.
 - E. Falls within JEDEC MO-229.

THERMAL PAD MECHANICAL DATA

DRF (S-PWSON-N8)

PLASTIC SMALL OUTLINE NO-LEAD

THERMAL INFORMATION

This package incorporates an exposed thermal pad that is designed to be attached directly to an external heatsink. The thermal pad must be soldered directly to the printed circuit board (PCB). After soldering, the PCB can be used as a heatsink. In addition, through the use of thermal vias, the thermal pad can be attached directly to the appropriate copper plane shown in the electrical schematic for the device, or alternatively, can be attached to a special heatsink structure designed into the PCB. This design optimizes the heat transfer from the integrated circuit (IC).

For information on the Quad Flatpack No-Lead (QFN) package and its advantages, refer to Application Report, QFN/SOIC PCB Attachment, Texas Instruments Literature No. SLUA271. This document is available at www.ti.com.

The exposed thermal pad dimensions for this package are shown in the following illustration.

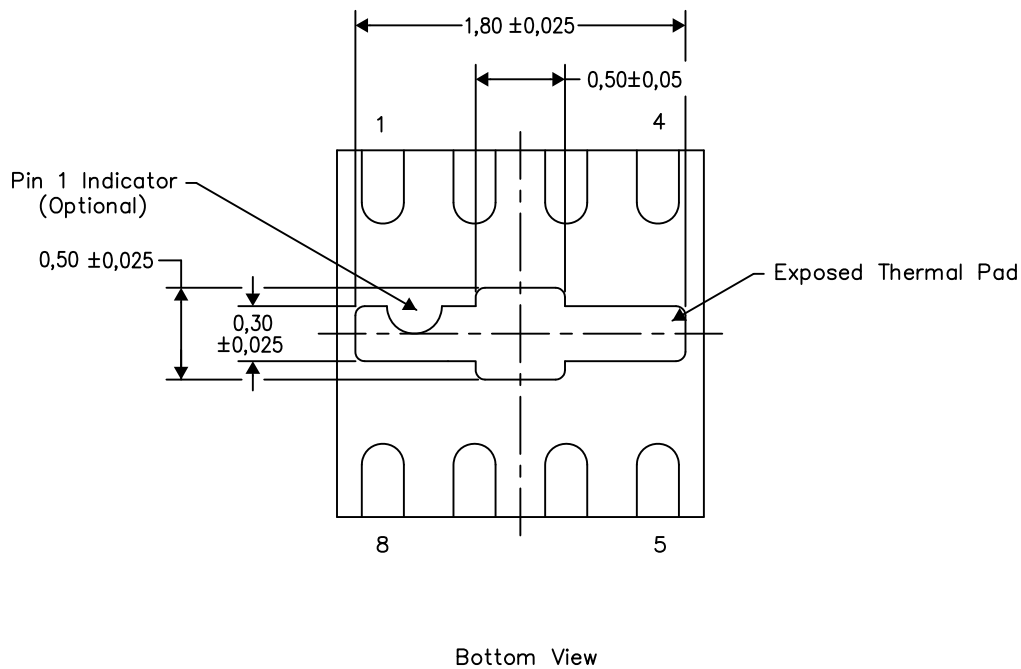

Exposed Thermal Pad Dimensions

4206840/H 12/14

NOTE: A. All linear dimensions are in millimeters

DRF (S-PWSON-N8)

PLASTIC SMALL OUTLINE NO-LEAD

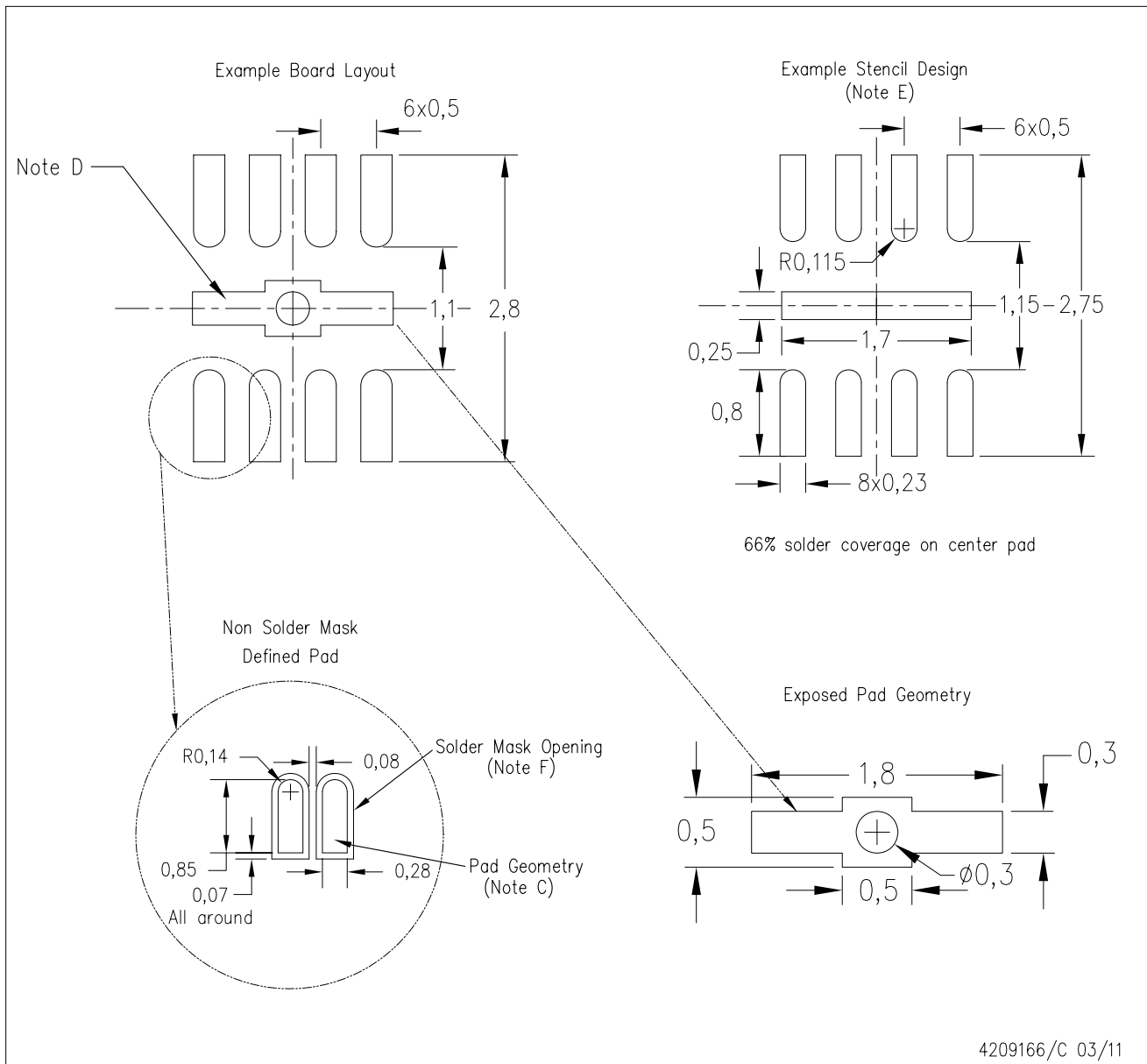

- NOTES:
- All linear dimensions are in millimeters.
 - This drawing is subject to change without notice.
 - Publication IPC-7351 is recommended for alternate designs.
 - This package is designed to be soldered to a thermal pad on the board. Refer to Application Note, Quad Flat-Pack Packages, Texas Instruments Literature No. SLUA271, and also the Product Data Sheets for specific thermal information, via requirements, and recommended board layout. These documents are available at www.ti.com <<http://www.ti.com>>.
 - Laser cutting apertures with trapezoidal walls and also rounding corners will offer better paste release. Customers should contact their board assembly site for stencil design recommendations. Refer to IPC 7525 for stencil design considerations.
 - Customers should contact their board fabrication site for minimum solder mask web tolerances between signal pads.

IMPORTANT NOTICE AND DISCLAIMER

TI PROVIDES TECHNICAL AND RELIABILITY DATA (INCLUDING DATASHEETS), DESIGN RESOURCES (INCLUDING REFERENCE DESIGNS), APPLICATION OR OTHER DESIGN ADVICE, WEB TOOLS, SAFETY INFORMATION, AND OTHER RESOURCES "AS IS" AND WITH ALL FAULTS, AND DISCLAIMS ALL WARRANTIES, EXPRESS AND IMPLIED, INCLUDING WITHOUT LIMITATION ANY IMPLIED WARRANTIES OF MERCHANTABILITY, FITNESS FOR A PARTICULAR PURPOSE OR NON-INFRINGEMENT OF THIRD PARTY INTELLECTUAL PROPERTY RIGHTS.

These resources are intended for skilled developers designing with TI products. You are solely responsible for (1) selecting the appropriate TI products for your application, (2) designing, validating and testing your application, and (3) ensuring your application meets applicable standards, and any other safety, security, or other requirements. These resources are subject to change without notice. TI grants you permission to use these resources only for development of an application that uses the TI products described in the resource. Other reproduction and display of these resources is prohibited. No license is granted to any other TI intellectual property right or to any third party intellectual property right. TI disclaims responsibility for, and you will fully indemnify TI and its representatives against, any claims, damages, costs, losses, and liabilities arising out of your use of these resources.

TI's products are provided subject to TI's Terms of Sale (www.ti.com/legal/termsofsale.html) or other applicable terms available either on ti.com or provided in conjunction with such TI products. TI's provision of these resources does not expand or otherwise alter TI's applicable warranties or warranty disclaimers for TI products.

Mailing Address: Texas Instruments, Post Office Box 655303, Dallas, Texas 75265
Copyright © 2020, Texas Instruments Incorporated

Looking for pricing, stock, or lifecycle information?

Click below to explore more details on WIN SOURCE:

 [View TUSB501DRFR on WIN SOURCE](#)

 [Texas Instruments](#) Information

Optimize Your Supply Chain with WIN SOURCE Solutions

-  Global Sourcing Solution
-  Obsolete Management
-  Cost Control Management
-  Shortage Management
-  Alternative Solution
-  Excess Inventory Management