



THE DATASHEET OF TUSB3210PM



TUSB3210 Universal Serial Bus General-Purpose Device Controller

1 Features

- Multiproduct Support With One Code and One Chip (up to 16 Products With One Chip)
- Fully Compliant With USB 2.0 Full-Speed Specifications: TID #40270269
- Supports 12-Mbits/s USB Data Rate (Full Speed)
- Supports USB Suspend, Resume, and Remote Wake-Up Operation
- Integrated 8052 Microcontroller With:
 - 256 × 8 RAM for Internal Data
 - 8K × 8 RAM Code Space Available for Downloadable Firmware From Host or I²C Port
 - 8K × 8 RAM for Development
 - 512 × 8 Shared RAM Used for Data Buffers and Endpoint Descriptor Blocks (EDB)
 - Buffer Space for USB Packet Transactions
 - Four 8052 GPIO Ports: Port 0, 1, 2, and 3
 - Master I²C Controller for External Slave Device Access
 - Watchdog Timer
- Operates From a 12-MHz Crystal
- On-Chip PLL Generates 48 MHz
- Supports a Total of Three Input and Three Output (Interrupt, Bulk) Endpoints
- Power-Down Mode
- 64-Pin LQFP Package

2 Applications

- Keyboards
- Barcode Readers
- Flash Memory Readers
- General-Purpose Controllers

3 Description

The TUSB3210 device is a USB-based controller targeted as a general-purpose MCU with GPIO. The TUSB3210 device has 8K × 8 RAM space for application development. In addition, the programmability of the TUSB3210 device makes it flexible enough to use for various other general USB I/O applications.

Device Information⁽¹⁾

PART NUMBER	PACKAGE	BODY SIZE (NOM)
TUSB3210	LQFP (64)	10.00 mm × 10.00 mm

(1) For all available packages, see the orderable addendum at the end of the data sheet.

Application Example

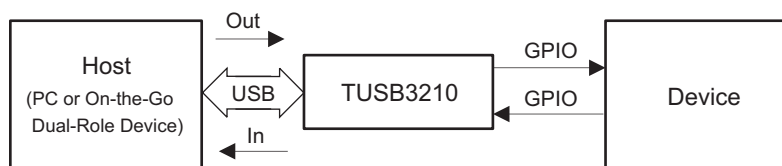

Table of Contents

1 Features	1	7.5 Register Maps	10
2 Applications	1	8 Application and Implementation	39
3 Description	1	8.1 Application Information.....	39
4 Revision History	2	8.2 Typical Applications	40
5 Pin Configuration and Functions	4	9 Power Supply Recommendations	43
6 Specifications	6	10 Layout	43
6.1 Absolute Maximum Ratings	6	10.1 Layout Guidelines	43
6.2 ESD Ratings.....	6	10.2 Layout Example	44
6.3 Recommended Operating Conditions.....	6	11 Device and Documentation Support	45
6.4 Thermal Information	6	11.1 Documentation Support	45
6.5 Electrical Characteristics.....	7	11.2 Community Resources.....	45
7 Detailed Description	8	11.3 Trademarks	45
7.1 Overview	8	11.4 Electrostatic Discharge Caution.....	45
7.2 Functional Block Diagram	8	11.5 Glossary	45
7.3 Feature Description.....	9	12 Mechanical, Packaging, and Orderable	
7.4 Device Functional Modes.....	9	Information	45

4 Revision History

REVISION	DATE	CHANGES
F	December 2015	1. <i>Pin Configuration and Functions</i> section, <i>ESD Ratings</i> table, <i>Thermal Information</i> table, <i>Feature Description</i> section, <i>Device Functional Modes</i> , <i>Application and Implementation</i> section, <i>Power Supply Recommendations</i> section, <i>Layout</i> section, <i>Device and Documentation Support</i> section, and <i>Mechanical, Packaging, and Orderable Information</i> section
E	August 2007	1. Deleted reference to 8K x 8 ROM 2. Clarified Section 2.2.2, bit 0. 3. Clarified Section 2.6.5 (VID/PID support)
D	June 2004	1. Corrected description for pin 20 (TEST2). 2. Added description of programmable delay to the <i>P2[7:0]</i> , <i>P3.3 Interrupt (INT1)</i> section. 3. Added delay values for I[3:0] to the INTCFG register description.
C	Nov-2003	1. Added USB logo to cover page. 2. Corrected pin 37 (1.8VDD) polarity in <i>Terminal Functions</i> table. 3. Removed note for pin 20 (TEST2) from <i>Terminal Functions</i> table. 4. Removed application diagram Figure 7 . 5. Clarified Section 4-2, Reset Timing
B	April 2003	1. Grammatical clean-up 2. Clarification on pin 55 (P3.3) and its functionality as $\overline{INT1}$. 3. Additional corrections in the <i>8052 Interrupt and Status Registers</i> section.

Revision History (continued)

REVISION	DATE	CHANGES
A	February 2003	<ol style="list-style-type: none"> 1. Removed most references to ROM version, including the <i>MCU Memory Map (ROM Version)</i> figure. 2. Clarified pin names and descriptions for pins 8 (S2), 9 (S3), 21 (GND), 37 (VDD18), 57 (P3.1/S1/TXD), and 58 (P3.0/S0/RXD). 3. Removed NOTE from cover page. 4. Expanded <i>Ordering Information</i> table. 5. Clarified pin functions for pins 14 (TEST0) and 15 (TEST1) (14 & 15) in <i>Terminal Functions</i> table. Simplified <i>Terminal Function</i> table for GPIO ports. 7. Added note on open-drain output pins for <i>Terminal Functions</i> table. 8. Added ET2 information to the <i>8052 Interrupt Location Map</i> table and further clarified the entire <i>8052 Interrupt and Status Registers</i> section. 9. Corrected quiescent and suspend current values in <i>Electrical Characteristics</i> table.
*	February 2001	Initial release

5 Pin Configuration and Functions

**PM Package
64-Pin LQFP
Top View**

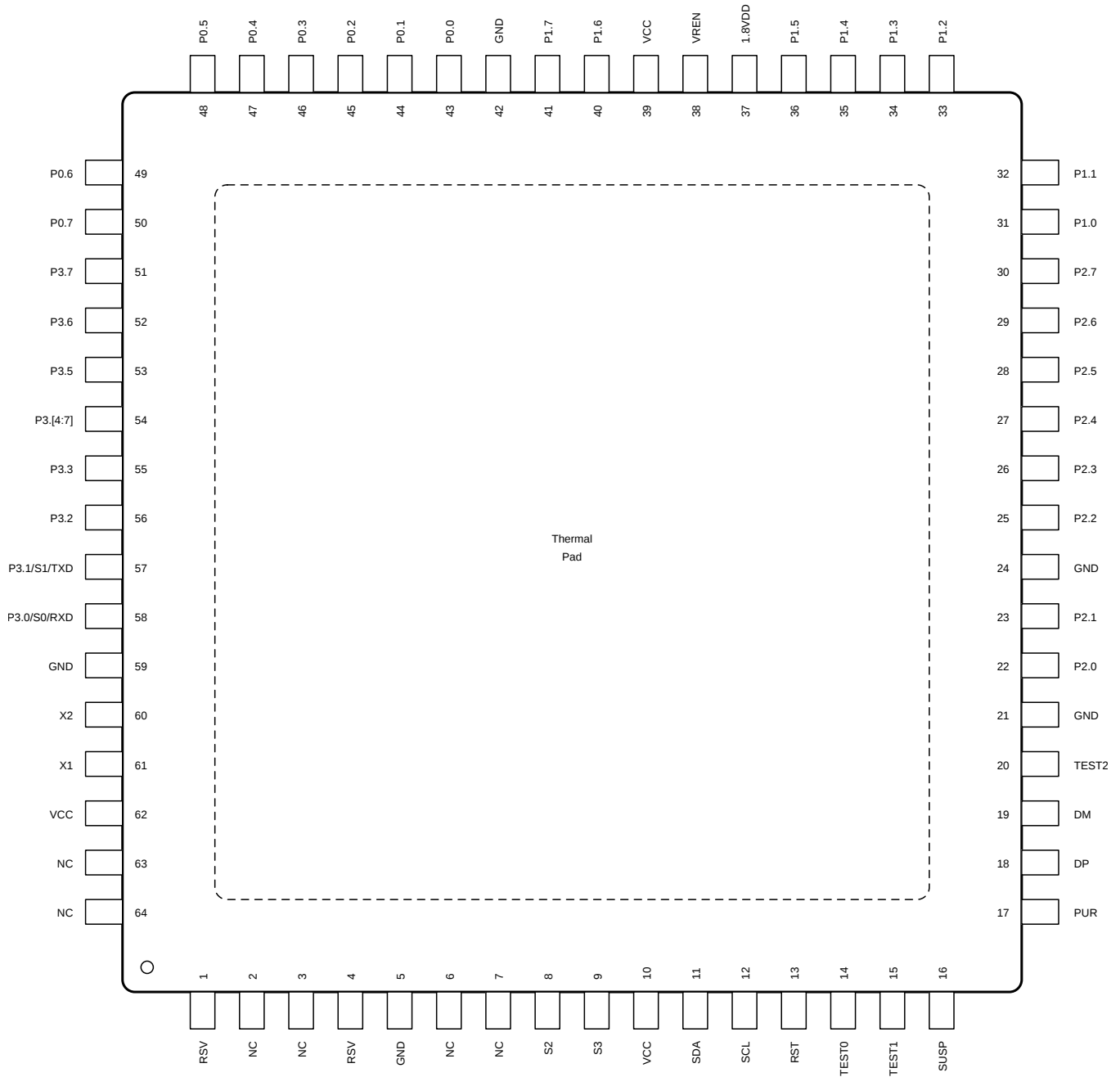

Pin Functions

PIN		I/O	DESCRIPTION
NAME	NO.		
1.8VDD	37	I/O	1.8 V. When \overline{VREN} is high, 1.8 V must be applied externally to provide current for the core during suspend.
DM	19	I/O	Differential data-minus USB
DP	18	I/O	Differential data-plus USB
GND	5, 21, 24, 42, 59	—	Power supply ground
NC	2, 3, 6, 7, 63, 64		No connection
P0.[0:7]	43, 44, 45, 46, 47, 48, 49, 50	I/O	General-purpose I/O port 0 bits 0–7, Schmitt-trigger input, 100- μ A active pullup, open-drain output
P1.[0:7]	31, 32, 33, 34, 35, 36, 40, 41	I/O	General-purpose I/O port 1 bits 0–7, Schmitt-trigger input, 100- μ A active pullup, open-drain output
P2.[0:7]	22, 23, 25, 26, 27, 28, 29, 30	I/O	General-purpose I/O port 2 bits 0–7, Schmitt-trigger input, 100- μ A active pullup, open-drain output
P3.0/S0/RXD	58	I/O	P3.0: General-purpose I/O port 3 bit 0, Schmitt-trigger input, 100- μ A active pullup, open-drain output
			S0: See VIDSTA: VID/PID Status Register
			RXD: Can be used as a UART interface
P3.1/S1/TXD	57	I/O	P3.1: General-purpose I/O port 3 bit 1, Schmitt-trigger input, 100- μ A active pullup, open-drain output
			S1: See VIDSTA: VID/PID Status Register
			TXD: Can be used as a UART interface
P3.2	56	I/O	General-purpose I/O port 3 bit 2, Schmitt-trigger input, 100- μ A active pullup, open-drain output; $\overline{INT0}$ only used internally (see Logical Interrupt Connection Diagram (INT0))
P3.3	55	I/O	General-purpose I/O port 3 bit 3, Schmitt-trigger input, 100- μ A active pullup, open-drain output; may support INT1 input, depending on configuration (see Figure 6)
P3.[4:7]	54, 53, 52, 51	I/O	General-purpose I/O port 3 bits 4–7, Schmitt-trigger input, 100- μ A active pullup, open-drain output
PUR	17	O	Pullup resistor connection pin (3-state) push-pull CMOS output (± 4 mA)
\overline{RST}	13	I	Controller master reset signal, Schmitt-trigger input, 100- μ A active pullup
RSV	1, 4	—	Reserved (Do not connect these pins.)
S2	8	I	General-purpose input, can be used for VID/PID selection under firmware control. This input has no internal pullup; therefore, it must be driven or pulled either low or high and cannot be left unconnected.
S3	9	I	General-purpose input. This input has no internal pullup; therefore, it must be driven or pulled either low or high and cannot be left unconnected.
SCL	12	O	Serial clock I ² C; push-pull output
SDA	11	I/O	Serial data I ² C; open-drain output
SUSP	16	O	Suspend status signal: suspended (HIGH); unsuspended (LOW)
TEST0	14	I	Test input0, Schmitt-trigger input, 100- μ A active pullup
TEST1	15	I	Test input1, Schmitt-trigger input, 100- μ A active pullup
TEST2	20	I	Test input2, Schmitt-trigger input, 100- μ A active pullup. This pin is reserved for testing purposes and must be left unconnected.
VCC	10, 39, 62	—	Power supply input, 3.3-V typical
\overline{VREN}	38	I	Voltage regulator enable: enable active-LOW; disable active-HIGH
X1	61	I	12-MHz crystal input
X2	60	O	12-MHz crystal output

6 Specifications

6.1 Absolute Maximum Ratings

over operating free-air temperature range (unless otherwise noted)⁽¹⁾

		MIN	MAX	UNIT
V _{CC}	Supply voltage	-0.5	4	V
V _I	Input voltage	-0.5	V _{CC} + 0.5	V
V _O	Output voltage	-0.5	V _{CC} + 0.5	V
I _{IK}	Input clamp current		±20	mA
I _{OK}	Output clamp current		±20	mA
T _{stg}	Storage temperature	-65	150	°C

- (1) Stresses beyond those listed under *Absolute Maximum Ratings* may cause permanent damage to the device. These are stress ratings only, and functional operation of the device at these or any other conditions beyond those indicated under *Recommended Operating Conditions* is not implied. Exposure to absolute-maximum-rated conditions for extended periods may affect device reliability.

6.2 ESD Ratings

		VALUE	UNIT
V _(ESD)	Electrostatic discharge	Human body model (HBM), per ANSI/ESDA/JEDEC JS-001 ⁽¹⁾	±2000
		Charged-device model (CDM), per JEDEC specification JESD22-C101 ⁽²⁾	±500

- (1) JEDEC document JEP155 states that 500-V HBM allows safe manufacturing with a standard ESD control process.
 (2) JEDEC document JEP157 states that 250-V CDM allows safe manufacturing with a standard ESD control process.

6.3 Recommended Operating Conditions

		MIN	NOM	MAX	UNIT
V _{CC}	Supply voltage	3	3.3	3.6	V
V _I	Input voltage	0		V _{CC}	V
V _{IH}	High-level input voltage	2		V _{CC}	V
V _{IL}	Low-level input voltage	0		0.8	V
T _A	Operating temperature	0		70	°C

6.4 Thermal Information

THERMAL METRIC ⁽¹⁾		TUSB3210	UNIT
		PM (LQFP)	
		64 PINS	
R _{θJA}	Junction-to-ambient thermal resistance	61.3	°C/W
R _{θJC(top)}	Junction-to-case (top) thermal resistance	25.1	°C/W
R _{θJB}	Junction-to-board thermal resistance	32.4	°C/W
Ψ _{JT}	Junction-to-top characterization parameter	2.4	°C/W
Ψ _{JB}	Junction-to-board characterization parameter	32.1	°C/W
R _{θJC(bot)}	Junction-to-case (bottom) thermal resistance	n/a	°C/W

- (1) For more information about traditional and new thermal metrics, see the *Semiconductor and IC Package Thermal Metrics* application report, [SPRA953](#).

6.5 Electrical Characteristics

 $T_A = 25^\circ\text{C}$, $V_{CC} = 3.3\text{ V} \pm 0.3\text{ V}$, $\text{GND} = 0\text{ V}$

PARAMETER		TEST CONDITIONS	MIN	TYP	MAX	UNIT
V_{OH}	High-level output voltage	$I_{OH} = -4\text{ mA}$	$V_{CC} - 0.5$			V
V_{OL}	Low-level output voltage	$I_{OL} = 4\text{ mA}$			0.5	V
V_{IT+}	Positive input threshold voltage	$V_I = V_{IH}$			2	V
V_{IT-}	Negative input threshold voltage	$V_I = V_{IL}$	0.8			V
V_{hys}	Hysteresis ($V_{IT+} - V_{IT-}$)	$V_I = V_{IH}$		1		V
I_{IH}	High-level input current	$V_I = V_{IH}$			± 1	μA
I_{IL}	Low-level input current	$V_I = V_{IL}$			± 1	μA
I_{OZ}	Output leakage current (Hi-Z)	$V_I = V_{CC}$ or V_{SS}			10	μA
C_I	Input capacitance			5		pF
C_O	Output capacitance			7		pF
I_{CC}	Quiescent			25	45	mA
I_{CCx}	Suspend				45	μA
$I_{CCx1.8}$	Suspend 1.8 VDD				1	μA

7 Detailed Description

7.1 Overview

The TUSB3210 device is a USB-based controller targeted as a general-purpose MCU with GPIO. The TUSB3210 device has 8K × 8 RAM space for application development. In addition, the programmability of the TUSB3210 device makes it flexible enough to use for various general USB I/O applications. Unique vendor identification and product identification (VID/PID) can be selected without the use of an external EEPROM. The onboard oscillator generates the internal system clocks using a 12-MHz crystal. The TUSB3210 device can be programmed through an inter-IC (I²C) serial interface at power on from an EEPROM, or the application firmware can be downloaded from a host PC through USB. The popular 8052-based microprocessor allows several third-party standard tools to be used for application development. In addition, the vast amounts of application code available in the general market can also be used (this may or may not require some code modification due to hardware variations).

7.2 Functional Block Diagram

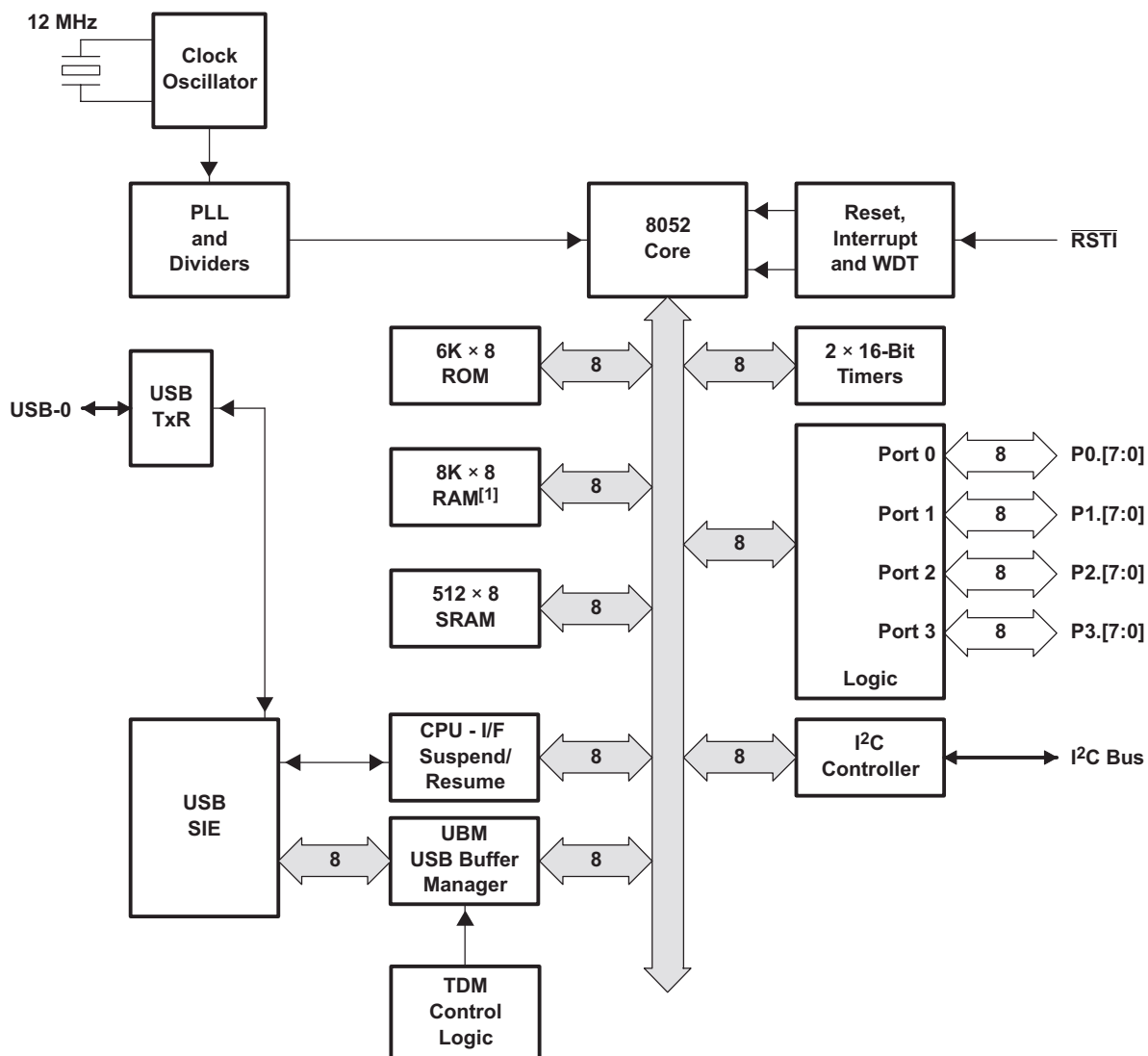

NOTE: 8K × 8 ROM version is available. Contact TI Marketing.

7.3 Feature Description

7.3.1 USB 2.0 Full-Speed Compliant

The TUSB3210 device is fully compliant with USB 2.0 full-speed; it supports 12 Mbits/s of USB data rate (full speed) as well as supporting USB suspend, resume, and remote wake-up operation.

7.3.2 Code Space Available

The TUSB3210 device has 8K × 8 RAM for firmware development. This firmware can be loaded through USB or using I²C serial interface from an EEPROM. The MCU executes a read from an external EEPROM and tests to determine if it contains the code (test for boot signature). If it contains the code, the MCU reads from EEPROM and writes to the 8K RAM in XDATA space. If not, the MCU proceeds to boot from the USB.

7.3.3 Clock Generation

The TUSB3210 device accepts a 12-MHz crystal input to drive an internal oscillator of 48 MHz. If a clock is provided to X1 instead of a crystal, X2 is left open. Otherwise, if a crystal is used, the connection must follow the guidelines shown in Figure 1. Because X1 and X2 are coupled to other leads and supplies on the PCB, it is important to keep the leads as short as possible and away from any switching leads. TI also recommends minimizing the capacitance between X1 and X2, which can be accomplished by shielding C1 and C2 with the clean ground lines.

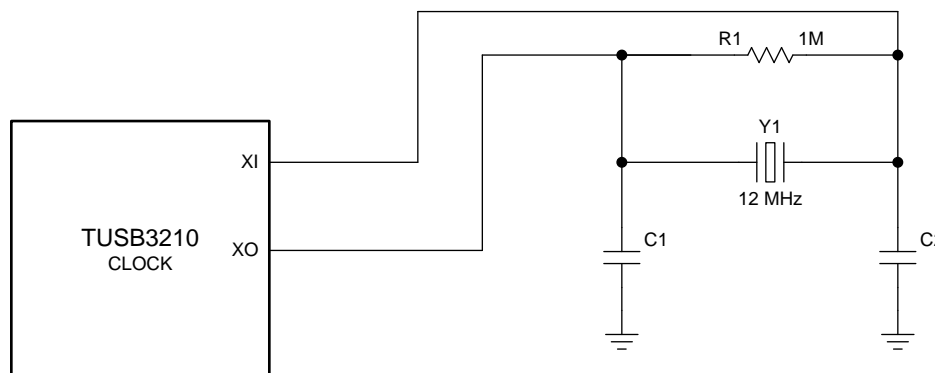

Figure 1. Clock Generation Diagram

7.3.4 UART Interface

The TUSB3210 device can use P3.0 and P3.1 as UART port; this UART is normally used for debug purposes.

7.4 Device Functional Modes

7.4.1 Interface Configuration

The TUSB3210 device contains onboard ROM microcode, which enables the MCU to enumerate the device as a USB peripheral. The ROM microcode can also load application code into internal RAM from either external memory through the I²C bus or from the host through the USB.

7.4.2 GPIO Controller

The TUSB3210 device is a USB-based controller targeted as a general-purpose MCU with GPIO. The TUSB3210 device has 8K × 8 RAM space for application development to control these GPIOs.

7.5 Register Maps

Table 1. Test0 and Test1 Functions

TEST0	TEST1	FUNCTION
0	0	Selects 48-MHz clock input (from an oscillator or other onboard clock source)
0	1	Reserved for testing purposes
1	0	Reserved for testing purposes
1	1	Selects 12-MHz crystal as clock source (default)

7.5.1 MCU Memory Map

Figure 2 illustrates the MCU memory map under boot and normal operation. It must be noted that the internal 256 bytes of IDATA are not shown because it is assumed to be in the standard 8052 location (0000 to 00FF). The shaded areas represent the internal ROM/RAM.

When the SDW bit = 0 (boot mode): The 6K ROM is mapped to address 0000–17FF and is duplicated in location 8000–97FF in code space. The internal 8K RAM is mapped to address range 0000–1FFF in data space. Buffers, MMR and I/O are mapped to address range (FD80–FFFF) in data space.

When the SDW bit = 1 (normal mode): The 6K ROM is mapped to 8000–97FF in code space. The internal 8K RAM is mapped to address range 0000–1FFF in code space. Buffers, MMR, and I/O are mapped to address range FD80–FFFF in data space.

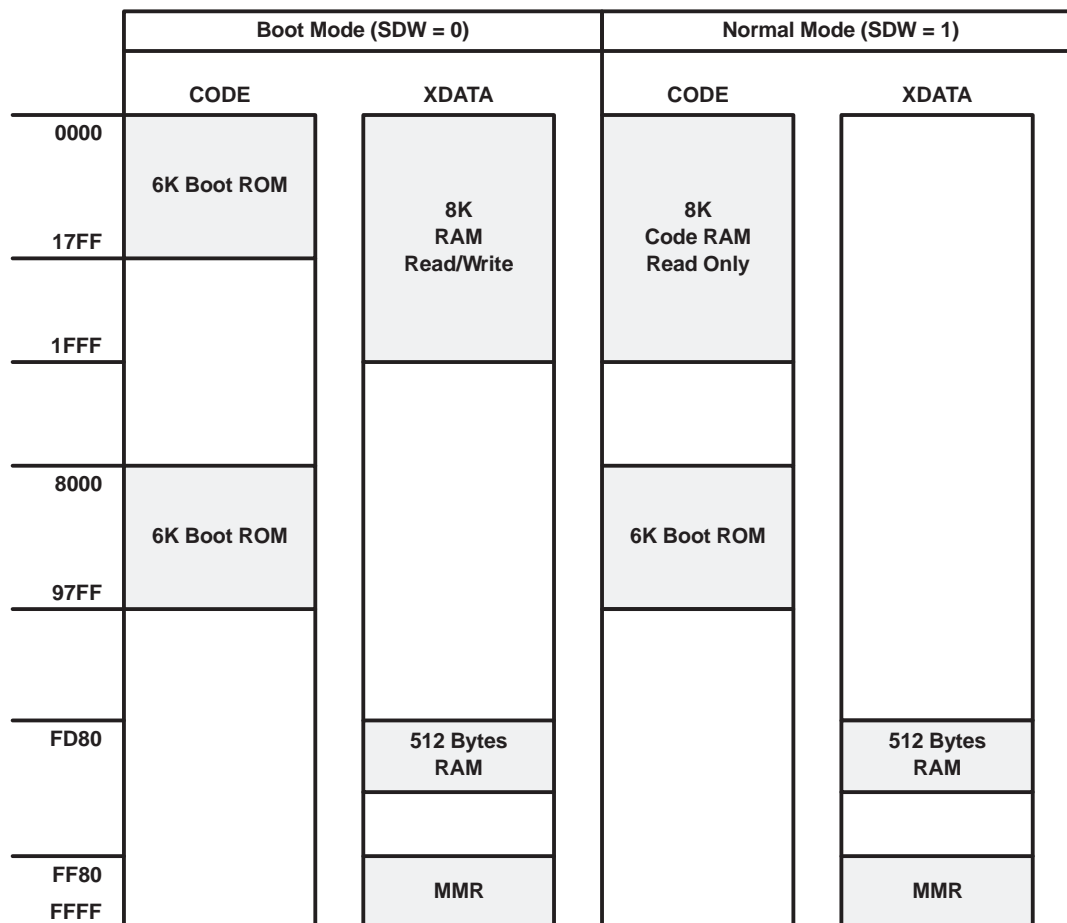
Figure 2. MCU Memory Map (TUSB3210)

7.5.2 Miscellaneous Registers

7.5.2.1 TUSB3210 Boot Operation

Because the code space is in RAM (with the exception of the boot ROM), the TUSB3210 firmware must be loaded from an external source. Two options for booting are available: an external serial EEPROM source can be connected to the I²C bus, or the host can be used through the USB. On device reset, the SDW bit (in the ROM register) and the CONT bit in the USB control register (USBCTL) are cleared. This configures the memory space to boot mode (see [Table 3](#)) and keeps the device *disconnected* from the host.

The first instruction is fetched from location 0000 (which is in the 6K ROM). The 8K RAM is mapped to XDATA space (location 0000h). The MCU executes a read from an external EEPROM and tests to determine if it contains the code (test for boot signature). If it contains the code, the MCU reads from EEPROM and writes to the 8K RAM in XDATA space. If not, the MCU proceeds to boot from the USB.

Once the code is loaded, the MCU sets SDW to 1. This switches the memory map to normal mode; that is, the 8K RAM is mapped to code space, and the MCU starts executing from location 0000h. When the switch is done, the MCU sets CONT to 1 (in USBCTL register) This *connects* the device to the USB bus, resulting in the normal USB device enumeration.

7.5.2.2 MCNFG: MCU Configuration Register

This register is used to control the MCU clock rate (R/O notation indicates read only by the MCU).

7	6	5	4	3	2	1	0
RSV	XINT	RSV	R3	R2	R1	R0	SDW
R/W	R/W	R/O	R/O	R/O	R/O	R/O	R/W

LEGEND: R/W = Read/Write; R = Read only; -n = value after reset

BIT	NAME	RESET	FUNCTION	
0	SDW	0	This bit enables/disables boot ROM.	
			SDW = 0	When clear, the MCU executes from the 6K boot ROM space. The boot ROM appears in two locations: 0000 and 8000h. The 8K RAM is mapped to XDATA space; therefore, read/write operation is possible. This bit is set by the MCU after the RAM load is completed. The MCU cannot clear this bit. It is cleared on power-up reset or function reset.
			SDW = 1	When set by the MCU, the 6K boot ROM maps to location 8000h, and the 8K RAM is mapped to code space, starting at location 0000h. At this point, the MCU executes from RAM, and write operation is disabled (no write operation is possible in code space).
4–1	R[3:0]	No effect	These bits reflect the device revision number.	
5	RSV	0	Reserved	
6	XINT	0	INT1 source control bit	
			XINT = 0	INT1 is connected to the P3.3 pin and operates as a standard INT1 interrupt.
			XINT = 1	INT1 is connected to the OR of the port-2 inputs.
7	RSV	0	Reserved	

TUSB3210

SLLS466G – FEBRUARY 2001 – REVISED DECEMBER 2015

www.ti.com
7.5.2.3 PUR_n: GPIO Pullup Register for Port n (n = 0 to 3)

PUR_0: GPIO pullup register for port 0

PUR_1: GPIO pullup register for port 1

PUR_2: GPIO pullup register for port 2

PUR_3: GPIO pullup register for port 3

7	6	5	4	3	2	1	0
PORT_n.7	PORT_n.6	PORT_n.5	PORT_n.4	PORT_n.3	PORT_n.2	PORT_n.1	PORT_n.0
R/W	R/W	R/W	R/W	R/W	R/W	R/W	R/W

LEGEND: R/W = Read/Write; R = Read only; -n = value after reset

BIT	NAME	RESET	FUNCTION
0–7	PORT_n.N (N = 0 to 7)	0	The MCU can write to this register. If the MCU sets this bit to 1, the internal pullup resistor is disconnected from the pin. If the MCU clears this bit to 0, the pullup resistor is connected to the pin. The pullup resistor is connected to the V _{CC} power supply.

7.5.2.4 INTCFG: Interrupt Configuration

7	6	5	4	3	2	1	0
RSV	RSV	RSV	RSV	I3	I2	I1	I0
R/O	R/O	R/O	R/O	R/W	R/W	R/W	R/W

LEGEND: R/W = Read/Write; R = Read only; -n = value after reset

BIT	NAME	RESET	FUNCTION	
0–3	I[3:0]	0010	The MCU can write to this register to set the interrupt delay time for port 2 on the MCU. The value of the lower nibble represents the delay in ms. Default after reset is 2 ms.	
			I[3:0]	Delay
			0000	5 ms
			0001	5 ms
			0010	2 ms (default)
			0011	3 ms
			0100	4 ms
			0101	5 ms
			0110	6 ms
			0111	7 ms
			1000	8 ms
			1001	9 ms
			1010	10 ms
			1011	5 ms
			1100	5 ms
1101	5 ms			
1110	5 ms			
1111	5 ms			
4–7	RSV	0	Reserved	

7.5.2.5 WDCSR: Watchdog Timer, Control, and Status Register

A watchdog timer (WDT) with 1-ms clock is provided. The watchdog timer works only when a USB start-of-frame has been detected by the TUSB3210. If this register is not accessed for a period of 32 ms, the WDT counter resets the MCU (see [Figure 3, Reset Diagram](#)). When the IDL bit in PCON is set, the WDT is suspended until an interrupt is detected. At this point, the IDL bit is cleared and the WDT resumes operation. The WDE bit of this register is cleared only on power up or USB reset (if enabled). When the MCU writes a 1 to the WDE bit of this register, the WDT starts running (W/O notation indicates write only by the MCU).

7	6	5	4	3	2	1	0
WDE	WDR	RSV	RSV	RSV	RSV	RSV	WDT
R/W	R/W	R/O	R/O	R/O	R/O	R/O	W/O

LEGEND: R/W = Read/Write; R = Read only; -n = value after reset

BIT	NAME	RESET	FUNCTION
0	WDT	0	The MCU must write a 1 to this bit to prevent the WDT from resetting the MCU. If the MCU does not write a 1 in a period of 31 ms, the WDT resets the device. Writing a 0 has no effect on the WDT. (WDT is a 5-bit counter using a 1-ms CLK.) This bit is read as 0.
5–1	RSV	0	Reserved = 0
6	WDR	0	Watchdog reset indication bit. This bit indicates if the reset occurred due to power-on reset or watchdog timer reset.
			WDR = 0 A power-up or USB reset occurred.
			WDR = 1 A watchdog time-out reset occurred. To clear this bit, the MCU must write a 1. Writing a 0 has no effect.
7	WDE	0	Watchdog timer enable.
			WDE = 0 Disabled
			WDE = 1 Enabled

7.5.2.6 PCON: Power Control Register (at SFR 87h)

7	6	5	4	3	2	1	0
SMOD	RSV	RSV	RSV	GF1	GF0	RSV	IDL
R/W	R/O	R/O	R/O	R/W	R/W	R/O	R/W

LEGEND: R/W = Read/Write; R = Read only; -n = value after reset

BIT	NAME	RESET	FUNCTION
0	IDL	0	MCU idle mode bit. This bit can be set by the MCU and is cleared only by the $\overline{\text{INT1}}$ interrupt.
			IDL = 0 The MCU is not in idle mode. This bit is cleared by the $\overline{\text{INT1}}$ interrupt logic when $\overline{\text{INT1}}$ is asserted for at least 400 μs .
			IDL = 1 The MCU is in idle mode and RAM is in low-power mode. The oscillator/APLL is off and the WDT is suspended. When in suspend mode, only $\overline{\text{INT1}}$ can be used to exit from idle state and generate an interrupt. $\overline{\text{INT1}}$ must be asserted for at least 400 μs for the interrupt to be recognized.
1	RSV	0	Reserved
3–2	GF[1:0]	00	General-purpose bits. The MCU can write and read them.
6–4	RSV	0	Reserved
7	SMOD	0	Double baud-rate control bit. For more information, see the UART serial interface in the M8052 core specification.

7.5.3 Buffers + I/O RAM Map

The address range from FD80 to FFFF is reserved for data buffers, set-up packet, endpoint descriptor blocks (EDB), and all I/O. RAM space of 512 bytes [FD80–FF7F] is used for EDB and buffers. The FF80–FFFF range is used for memory-mapped registers (MMR). represents the internal XDATA space allocation.

The address range from FD80 to FFFF is reserved for data buffers, set-up packet, endpoint descriptor blocks(EDB), and all I/O. RAM space of 512 bytes [FD80–FF7F] is used for EDB and buffers. The FF80–FFFF range is used for memory-mapped registers (MMR). [Table 2](#) represents the internal XDATA space allocation and [Table 3](#) describes the registers function.

Table 2. XDATA Space

DESCRIPTION	ADDRESS RANGE	
Internal memory-mapped registers (MMR)	FFFF	512-Byte RAM
	↑ FF80	
Endpoint descriptor blocks (EDB)	FF7F	
	↑ FF08	
Set-up packet buffer	FF07	
	↑ FF00	
Input endpoint-0 buffer	FEFF	
	↑ FEF8	
Output endpoint-0 buffer	FEF7	
	↑ FEF0	
Data buffers (368 bytes)	FEEF	
	↑ FD80	

Table 3. Memory-Mapped Register Summary (XDATA Range = FF80 → FFFF)

ADDRESS	REGISTER	DESCRIPTION
FFFF	FUNADR	FUNADR: Function address register
FFFE	USBSTA	USBSTA: USB status register
FFFD	USBMSK	USBMSK: USB interrupt mask register
FFFC	USBCTL	USBCTL: USB control register
↑	RESERVED	
FFF6	VIDSTA	VIDSTA: VID/PID status register
↑	RESERVED	
FFF3	I2CADR	I2CADR: I ² C address register
FFF2	I2CDAI	I2CDAI: I ² C data-input register
FFF1	I2CDAO	I2CDAO: I ² C data-output register
FFF0	I2CSTA	I2CSTA: I ² C status and control register
↑	RESERVED	
FF97	PUR3	Port 3 pullup resistor register
FF96	PUR2	Port 2 pullup resistor register
FF95	PUR1	Port 1 pullup resistor register
FF94	PUR0	Port 0 pullup resistor register
FF93	WDCSR	WDCSR: Watchdog timer, control and status register
FF92	VECINT	VECINT: Vector interrupt register
FF91	RESERVED	
FF90	MCNFG	MCNFG: MCU configuration register
↑	RESERVED	
FF84	INTCFG	INTCFG: Interrupt delay configuration register
FF83	OEPBCNT_0	OEPBCNT_0: Output endpoint-0 byte count register
FF82	OEPCNFG_0	OEPCNFG_0: Output endpoint-0 configuration register
FF81	IEPBCNT_0	IEPBCNT_0: Input endpoint-0 byte count register
FF80	IEPCNFG_0	IEPCNFG_0: Input endpoint-0 configuration register

7.5.4 Endpoint Descriptor Block (EDB-1 to EDB-3)

Data transfers between USB, MCU and external devices are defined by an endpoint descriptor block (EDB). Four input and four output EDBs are provided. With the exception of EDB-0 (I/O endpoint 0), all EDBs are located in SRAM as shown in [Table 4](#). Each EDB contains information describing the X and Y buffers. In addition, it provides general status information.

Table 4. EDB and Buffer Allocations in XDATA

ADDRESS	SIZE	DESCRIPTION
FF7F ↑ FF60	32 bytes	RESERVED
FF5F ↑ FF58	8 bytes	Input endpoint 3: configuration
FF57 ↑ FF50	8 bytes	Input endpoint 2: configuration
FF4F ↑ FF48	8 bytes	Input endpoint 1: configuration
FF47 ↑ FF20	40 bytes	RESERVED
FF1F ↑ FF18	8 bytes	Output endpoint 3: configuration
FF17 ↑ FF10	8 bytes	Output endpoint 2: configuration
FF0F ↑ FF08	8 bytes	Output endpoint 1: configuration
FF07 ↑ FF00	8 bytes	Setup packet block
FEFF ↑ FEF8	8 bytes	Input endpoint 0: buffer
FEF7 ↑ FEF0	8 bytes	Output endpoint 0: buffer
FEEF ↑ FD80	368 bytes	Top of buffer space Buffer space Start of buffer space

Table 5 lists the EDB entries for EDB-1 to EDB-3. EDB-0 registers are described separately.

Table 5. EDB Entries in RAM (n = 1 to 3)

OFFSET	ENTRY NAME	DESCRIPTION
07	EPSIZXY_n	I/O endpoint_n: X/Y buffer size
06	EPBCTY_n	I/O endpoint_n: Y byte count
05	EPBBAY_n	I/O endpoint_n: Y buffer base address
04	SPARE	Not used
03	SPARE	Not used
02	EPBCTX_n	I/O endpoint_n: X byte count
01	EPBBAX_n	I/O endpoint_n: X buffer base address
00	EPCNF_n	I/O endpoint_n: configuration

7.5.4.1 OEPCNF_n: Output Endpoint Configuration (n = 1 to 3)

7	6	5	4	3	2	1	0
UBME	ISO	TOGGLE	DBUF	STALL	USBIE	RSV	RSV
R/W	R/W	R/W	R/W	R/W	R/W	R/O	R/O

LEGEND: R/W = Read/Write; R = Read only; -n = value after reset

BIT	NAME	RESET	FUNCTION
1-0	RSV	0	Reserved
2	USBIE	x	USB interrupt enable on transaction completion. Set/cleared by MCU.
			USBIE = 0 No interrupt
			USBIE = 1 Interrupt on transaction completion
3	STALL	0	USB stall condition indication. Set/cleared by MCU.
			STALL = 0 No stall
			STALL = 1 USB stall condition. If set by MCU, a STALL handshake is initiated and the bit is cleared by the MCU.
4	DBUF	x	Double buffer enable. Set/cleared by MCU.
			DBUF = 0 Primary buffer only (X-buffer only)
			DBUF = 1 Toggle bit selects buffer
5	TOGGLE	x	USB toggle bit. This bit reflects the toggle sequence bit of DATA0, DATA1.
6	ISO	x	ISO = 0 Non-isochronous transfer. This bit must be cleared by the MCU because only non-isochronous transfer is supported.
7	UBME	x	UBM enable/disable bit. Set/cleared by the MCU.
			UBME = 0 UBM cannot use this endpoint.
			UBME = 1 UBM can use this endpoint.

TUSB3210

SLLS466G – FEBRUARY 2001 – REVISED DECEMBER 2015

www.ti.com
7.5.4.2 OEPBBAX_n: Output Endpoint X-Buffer Base Address (n = 1 to 3)

7	6	5	4	3	2	1	0
A10	A9	A8	A7	A6	A5	A4	A3
R/W	R/W	R/W	R/W	R/W	R/W	R/W	R/W

LEGEND: R/W = Read/Write; R = Read only; -n = value after reset

BIT	NAME	RESET	FUNCTION
7–0	A[10:3]	x	A[10:3] of X-buffer base address (padded with 3 LSB of zeros for a total of 11 bits). This value is set by the MCU. UBM or DMA uses this value as the start address of a given transaction. Furthermore, UBM or DMA does not change this value at the end of a transaction.

7.5.4.3 OEPBCTX_n: Output Endpoint X-Byte Count (n = 1 to 3)

7	6	5	4	3	2	1	0
NAK	C6	C5	C4	C3	C2	C1	C0
R/W	R/W	R/W	R/W	R/W	R/W	R/W	R/W

LEGEND: R/W = Read/Write; R = Read only; -n = value after reset

BIT	NAME	RESET	FUNCTION
6–0	C[6:0]	x	X-Buffer Byte count: 000 0000b → Count = 0 000 0001b → Count = 1 byte . . . 011 1111b → Count = 63 bytes 100 0000b → Count = 64 bytes Any value ≥ 100 0001b produces unpredictable results.
7	NAK	x	NAK = 0 No valid data in buffer. Ready for host-out.
			NAK = 1 Buffer contains a valid packet from host (host-out request is NAK).

7.5.4.4 OEPBBAY_n: Output Endpoint Y-Buffer Base Address (n = 1 to 3)

7	6	5	4	3	2	1	0
A10	A9	A8	A7	A6	A5	A4	A3
R/W	R/W	R/W	R/W	R/W	R/W	R/W	R/W

LEGEND: R/W = Read/Write; R = Read only; -n = value after reset

BIT	NAME	RESET	FUNCTION
7–0	A[10:3]	x	A[10:3] of Y-buffer base address (padded with 3 LSB of zeros for a total of 11 bits). This value is set by the MCU. UBM or DMA uses this value as the start address of a given transaction. Furthermore, UBM or DMA does not change this value at the end of a transaction.

7.5.4.5 OEPBCTY_n: Output Endpoint Y-Byte Count (n = 1 to 3)

7	6	5	4	3	2	1	0
NAK	C6	C5	C4	C3	C2	C1	C0
R/W	R/W	R/W	R/W	R/W	R/W	R/W	R/W

LEGEND: R/W = Read/Write; R = Read only; -n = value after reset

BIT	NAME	RESET	FUNCTION
6–0	C[6:0]	x	Y-Buffer Byte count: 000 0000b → Count = 0 000 0001b → Count = 1 byte . . . 011 1111b → Count = 63 bytes 100 0000b → Count = 64 bytes Any value ≥ 100 0001b produces unpredictable results.
7	NAK	x	NAK = 0 No valid data in buffer. Ready for host-out
			NAK = 1 Buffer contains a valid packet from host (host-out request is NAK).

7.5.4.6 OEPSIZXY_n: Output Endpoint X-/Y-Buffer Size (n = 1 to 3)

7	6	5	4	3	2	1	0
RSV	S6	S5	S4	S3	S2	S1	S0
R/O	R/W	R/W	R/W	R/W	R/W	R/W	R/W

LEGEND: R/W = Read/Write; R = Read only; -n = value after reset

BIT	NAME	RESET	FUNCTION
6–0	S[6:0]	x	X- and Y-Buffer size: 000 0000b → Count = 0 000 0001b → Count = 1 byte . . . 011 1111b → Count = 63 bytes 100 0000b → Count = 64 bytes Any value ≥ 100 0001b produces unpredictable results.
7	RSV	0	Reserved

TUSB3210

SLLS466G – FEBRUARY 2001 – REVISED DECEMBER 2015

www.ti.com
7.5.4.7 IEP CNF_n: Input Endpoint Configuration (n = 1 to 3)

7	6	5	4	3	2	1	0
UBME	ISO	TOGGLE	DBUF	STALL	USBIE	RSV	RSV
R/W	R/W	R/W	R/W	R/W	R/W	R/O	R/O

LEGEND: R/W = Read/Write; R = Read only; -n = value after reset

BIT	NAME	RESET	FUNCTION
1–0	RSV	x	Reserved = 0
2	USBIE	x	USB interrupt enable on transaction completion
			USBIE = 0 No interrupt USBIE = 1 Interrupt on transaction completion
3	STALL	0	USB stall condition indication. Set by UBM, but can be set/cleared by the MCU.
			STALL = 0 No stall STALL = 1 USB stall condition. If set by the MCU, a STALL handshake is initiated and the bit is cleared automatically.
4	DBUF	x	Double buffer enable
			DBUF = 0 Primary buffer only (X-buffer only) DBUF = 1 Toggle bit selects buffer
5	TOGGLE	x	USB toggle bit. This bit reflects the toggle sequence bit of DATA0, DATA1.
6	ISO	x	ISO = 0 Non-isochronous transfer. This bit must be cleared by the MCU because only non-isochronous transfer is supported.
7	UBME	x	UBM enable/disable bit. Set/cleared by the MCU.
			UBME = 0 UBM cannot use this endpoint.
			UBME = 1 UBM can use this endpoint.

7.5.4.8 IEP BBA_{Xn}: Input Endpoint X-Buffer Base Address (n = 1 to 3)

7	6	5	4	3	2	1	0
A10	A9	A8	A7	A6	A5	A4	A3
R/W	R/W	R/W	R/W	R/W	R/W	R/W	R/W

LEGEND: R/W = Read/Write; R = Read only; -n = value after reset

BIT	NAME	RESET	FUNCTION
7–0	A[10:3]	x	A[10:3] of X-buffer base address (padded with 3 LSB of zeros for a total of 11 bits). This value is set by the MCU. UBM or DMA uses this value as the start address of a given transaction. Furthermore, UBM or DMA does not change this value at the end of a transaction.

7.5.4.9 IEP BCT_{Xn}: Input Endpoint X-Byte Base Address (n = 1 to 3)

7	6	5	4	3	2	1	0
NAK	C6	C5	C4	C3	C2	C1	C0
R/W	R/W	R/W	R/W	R/W	R/W	R/W	R/W

LEGEND: R/W = Read/Write; R = Read only; -n = value after reset

BIT	NAME	RESET	FUNCTION
6–0	C[6:0]	x	X-Buffer Byte count: 000 0000b → Count = 0 000 0001b → Count = 1 byte . . . 011 1111b → Count = 63 bytes 100 0000b → Count = 64 bytes Any value ≥ 100 0001b produces unpredictable results.
7	NAK	x	NAK = 0 Buffer contains a valid packet for host-in transaction
			NAK = 1 Buffer is empty (host-in request is NAK)

7.5.4.10 IEPBBAY_n: Input Endpoint Y-Buffer Base Address (n = 1 to 3)

7	6	5	4	3	2	1	0
A10	A9	A8	A7	A6	A5	A4	A3
R/W	R/W	R/W	R/W	R/W	R/W	R/W	R/W

LEGEND: R/W = Read/Write; R = Read only; -n = value after reset

BIT	NAME	RESET	FUNCTION
7–0	A[10:3]	x	A[10:3] of Y-buffer base address (padded with 3 LSB of zeros for a total of 11 bits). This value is set by the MCU. UBM or DMA uses this value as the start address of a given transaction. Furthermore, UBM or DMA does not change this value at the end of a transaction.

7.5.4.11 IEPBCTY_n: Input Endpoint Y-Byte Count (n = 1 to 3)

7	6	5	4	3	2	1	0
NAK	C6	C5	C4	C3	C2	C1	C0
R/W	R/W	R/W	R/W	R/W	R/W	R/W	R/W

LEGEND: R/W = Read/Write; R = Read only; -n = value after reset

BIT	NAME	RESET	FUNCTION
6–0	C[6:0]	x	X-Buffer Byte count: 000 0000b → Count = 0 000 0001b → Count = 1 byte . . . 011 1111b → Count = 63 bytes 100 0000b → Count = 64 bytes Any value ≥ 100 0001b produces unpredictable results.
7	NAK	x	NAK = 0 Buffer contains a valid packet for host-in transaction NAK = 1 Buffer is empty (host-in request is NAK)

7.5.4.12 IEPSIZXY_n: Input Endpoint X-/Y-Buffer Size (n = 1 to 3)

7	6	5	4	3	2	1	0
RSV	S6	S5	S4	S3	S2	S1	S0
R/O	R/W	R/W	R/W	R/W	R/W	R/W	R/W

LEGEND: R/W = Read/Write; R = Read only; -n = value after reset

BIT	NAME	RESET	FUNCTION
6–0	S[6:0]	x	X- and Y-Buffer size: 000 0000b → Count = 0 000 0001b → Count = 1 byte . . . 011 1111b → Count = 63 bytes 100 0000b → Count = 64 bytes Any value ≥ 100 0001b produces unpredictable results.
7	RSV	x	Reserved

7.5.5 Endpoint-0 Descriptor Registers

Unlike EDB-1 to EDB-3, which are defined as memory entries in SRAM, endpoint-0 is described by a set of four registers (two for output and two for input). [Table 6](#) defines the registers and their respective addresses used for EDB-0 description. EDB-0 has no *Base-Address Register*, because these addresses are hardwired to FEF8 and FEF0. Note that the bit positions have been preserved to provide consistency with EDB-n (n = 1 to 3).

Table 6. Input/Output EDB-0 Registers

ADDRESS	REGISTER NAME	DESCRIPTION	BASE ADDRESS
FF83	OEPBCNT_0	Output endpoint_0: byte-count register	FEF0
FF82	OEPCNFG_0	Output endpoint_0: configuration register	
FF81	IEPBCNT_0	Input endpoint_0: byte-count register	FEF8
FF80	IEPCNFG_0	Input endpoint_0: configuration register	

7.5.5.1 IEPCNFG_0: Input Endpoint-0 Configuration Register

7	6	5	4	3	2	1	0
UBME	RSV	TOGGLE	RSV	STALL	USBIE	RSV	RSV
R/W	R/O	R/O	R/O	R/W	R/W	R/O	R/O

LEGEND: R/W = Read/Write; R = Read only; -n = value after reset

BIT	NAME	RESET	FUNCTION	
1–0	RSV	0	Reserved	
2	USBIE	0	USB interrupt enable on transaction completion. Set/cleared by the MCU	
			USBIE = 0	No interrupt
			USBIE = 1	Interrupt on transaction completion
3	STALL	0	USB stall condition indication. Set/cleared by the MCU	
			STALL = 0	No stall
			STALL = 1	USB stall condition. If set by the MCU, a STALL handshake is initiated and the bit is cleared automatically by the next setup transaction.
4	RSV	0	Reserved	
5	TOGGLE	0	USB toggle bit. This bit reflects the toggle sequence bit of DATA0, DATA1.	
6	RSV	0	Reserved	
7	UBME	0	UBM enable/disable bit. Set/cleared by the MCU	
			UBME = 0	UBM cannot use this endpoint.
			UBME = 1	UBM can use this endpoint.

7.5.5.2 IEPBCNT_0: Input Endpoint-0 Byte-Count Register

7	6	5	4	3	2	1	0
NAK	RSV	RSV	RSV	C3	C2	C1	C0
R/W	R/O	R/O	R/O	R/W	R/W	R/W	R/W

LEGEND: R/W = Read/Write; R = Read only; -n = value after reset

BIT	NAME	RESET	FUNCTION	
3–0	C[3:0]	0000	Byte count: 0000b → Count = 0 . . 0111b → Count = 7 1000b → Count = 8 1001b to 1111b are reserved. (If used, defaults to 8)	
6–4	RSV	0	Reserved	
7	NAK	1	NAK = 0	Buffer contains a valid packet for host-in transaction.
			NAK = 1	Buffer is empty (host-in request is NAK).

7.5.5.3 OEPCNFG_0: Output Endpoint-0 Configuration Register

7	6	5	4	3	2	1	0
UBME	RSV	TOGGLE	RSV	STALL	USBIE	RSV	RSV
R/W	R/O	R/O	R/O	R/W	R/W	R/O	R/O

LEGEND: R/W = Read/Write; R = Read only; -n = value after reset

BIT	NAME	RESET	FUNCTION	
1–0	RSV	0	Reserved	
2	USBIE	0	USB interrupt enable on transaction completion. Set/cleared by the MCU	
			USBIE = 0	No interrupt
			USBIE = 1	Interrupt on transaction completion
3	STALL	0	USB stall condition indication. Set/cleared by the MCU	
			STALL = 0	No stall
			STALL = 1	USB stall condition. If set by the MCU, a STALL handshake is initiated and the bit is cleared automatically.
4	RSV	0	Reserved	
5	TOGGLE	0	USB toggle bit. This bit reflects the toggle sequence bit of DATA0, DATA1.	
6	RSV	0	Reserved	
7	UBME	0	UBM enable/disable bit. Set/cleared by the MCU	
			UBME = 0	UBM cannot use this endpoint.
			UBME = 1	UBM can use this endpoint.

TUSB3210

SLLS466G – FEBRUARY 2001 – REVISED DECEMBER 2015

www.ti.com
7.5.5.4 OEPBCNT_0: Output Endpoint-0 Byte-Count Register

7	6	5	4	3	2	1	0
NAK	RSV	RSV	RSV	C3	C2	C1	C0
R/W	R/O	R/O	R/O	R/W	R/W	R/W	R/W

LEGEND: R/W = Read/Write; R = Read only; -n = value after reset

BIT	NAME	RESET	FUNCTION
3–0	C[3:0]	0000	Byte count: 0000b → Count = 0 . . 0111b → Count = 7 1000b → Count = 8 1001b to 1111b are reserved (if used, defaults to 8).
6–4	RSV	0	Reserved = 0
7	NAK	1	NAK = 0 No valid data in buffer. Ready for host-out NAK = 1 Buffer contains a valid packet from host (NAK the host).

7.5.6 USB Registers
7.5.6.1 FUNADR: Function Address Register

This register contains the device function address.

7	6	5	4	3	2	1	0
RSV	FA6	FA5	FA4	FA3	FA2	FA1	FA0
R/O	R/W	R/W	R/W	R/W	R/W	R/W	R/W

LEGEND: R/W = Read/Write; R = Read only; -n = value after reset

BIT	NAME	RESET	FUNCTION
6–0	FA[6:0]	000 0000	These bits define the current device address assigned to the function. The MCU writes a value to this register as a result of a <i>SET-ADDRESS</i> host command.
7	RSV	0	Reserved

7.5.6.2 USBSTA: USB Status Register

All bits in this register are set by the hardware and are cleared by the MCU when writing a 1 to the proper bit location (writing a 0 has no effect). In addition, each bit can generate an interrupt if its corresponding mask bit is set (R/C notation indicates read and clear only by the MCU).

7	6	5	4	3	2	1	0
RSTR	SUSR	RESR	PWOFF	PWON	SETUP	RSV	STPOW
R/C	R/C	R/C	R/C	R/C	R/C	R/O	R/C

LEGEND: R/W = Read/Write; R = Read only; -n = value after reset

BIT	NAME	RESET	FUNCTION
0	STPOW	0	SETUP overwrite bit. Set by hardware when setup packet is received while there is already a packet in the setup buffer.
			STPOW = 0 MCU can clear this bit by writing a 1. (Writing 0 has no effect.)
			STPOW = 1 SETUP overwrite
1	RSV	0	Reserved
2	SETUP	0	SETUP transaction received bit. As long as SETUP is 1, IN and OUT on endpoint-0 are NAK regardless of the value of their real NAK bits.
			SETUP = 0 MCU can clear this bit by writing a 1. (Writing 0 has no effect.)
			SETUP = 1 SETUP transaction has been received.
3	PWON	0	Power-on request for port 3. This bit indicates if power on to port 3 has been received. This bit generates a PWON interrupt (if enabled).
			PWON = 0 MCU can clear this bit by writing a 1. (Writing 0 has no effect.)
			PWON = 1 Power on to port 3 has been received.
4	PWOFF	0	Power-off request for port 3. This bit indicates whether power off to port 3 has been received. This bit generates a PWOFF interrupt (if enabled).
			PWOFF = 0 MCU can clear this bit by writing a 1. (Writing 0 has no effect.)
			PWOFF = 1 Power off to port 3 has been received.
5	RESR	0	Function resume request bit
			RESR = 0 MCU can clear this bit by writing a 1. (Writing 0 has no effect.)
			RESR = 1 Function resume is detected.
6	SUSR	0	Function suspended request bit. This bit is set in response to a global or selective suspend condition.
			SUSR = 0 MCU can clear this bit by writing a 1. (Writing 0 has no effect.)
			SUSR = 1 Function suspend is detected.
7	RSTR	0	Function reset request bit. This bit is set in response to host initiating a port reset. This bit is not affected by USB function reset.
			RSTR = 0 MCU can clear this bit by writing a 1. (Writing 0 has no effect.)
			RSTR = 1 Function reset is detected.

TUSB3210

SLLS466G – FEBRUARY 2001 – REVISED DECEMBER 2015

www.ti.com
7.5.6.3 USBMSK: USB Interrupt Mask Register

7	6	5	4	3	2	1	0
RSTR	SUSR	RESR	PWOFF	PWON	SETUP	RSV	STPOW
R/W	R/W	R/W	R/W	R/W	R/W	R/O	R/W

LEGEND: R/W = Read/Write; R = Read only; -n = value after reset

BIT	NAME	RESET	FUNCTION	
0	STPOW	0	SETUP overwrite interrupt enable bit	
			STPOW = 0	STPOW interrupt disabled
			STPOW = 1	STPOW interrupt enabled
1	RSV	0	Reserved = 0	
2	SETUP	0	SETUP interrupt enable bit	
			SETUP = 0	SETUP interrupt disabled
			SETUP = 1	SETUP interrupt enabled
3	PWON	0	Power-on interrupt enable bit	
			PWON = 0	PWON interrupt disabled
			PWON = 1	PWON interrupt enabled
4	PWOFF	0	Power-off interrupt enable bit	
			PWOFF = 0	PWOFF interrupt disabled
			PWOFF = 1	PWOFF interrupt enabled
5	RESR	0	Function resume interrupt enable	
			RESR = 0	Function resume interrupt disabled
			RESR = 1	Function resume interrupt enabled
6	SUSR	0	Function suspend interrupt enable	
			SUSR = 0	Function suspend interrupt disabled
			SUSR = 1	Function suspend interrupt enabled
7	RSTR	0	Function reset interrupt enable	
			RSTR = 0	Function reset interrupt disabled
			RSTR = 1	Function reset interrupt enabled

7.5.6.4 USBCTL: USB Control Register

Unlike the other registers, this register is cleared by the power-up-reset signal only. The USB reset cannot reset this register (see the reset diagram in [Figure 3](#)).

7	6	5	4	3	2	1	0
CONT	RSV	RWUP	FRSTE	RWE	B/S	SIR	DIR
R/W	R/O	R/W	R/W	R/W	R/O	R/W	R/W

LEGEND: R/W = Read/Write; R = Read only; -n = value after reset

BIT	NAME	RESET	FUNCTION	
0	DIR	0	As a response to a setup packet, the MCU decodes the request and sets or clears this bit to reflect the data transfer direction.	
			DIR = 0	USB data OUT transaction (from host to TUSB3210)
			DIR = 1	USB data IN transaction (from TUSB3210 to host)
1	SIR	0	SETUP interrupt status bit. This bit is controlled by the MCU to indicate to the hardware when the SETUP interrupt is being served.	
			SIR = 0	SETUP interrupt is not served. MCU clears this bit before exiting the SETUP interrupt routine.
			SIR = 1	SETUP interrupt is in progress. MCU sets this bit when servicing the SETUP interrupt.
2	B/S	0	Bus-/self-power control bit	
			B/S = 0	The device is bus-powered.
			B/S = 1	The device is self-powered.
3	RWE	0	Remote wake-up enable bit	
			RWE = 0	MCU clears this bit when host sends command to clear the feature.
			RWE = 1	MCU writes 1 to this bit when host sends <i>set device feature command</i> to enable the remote wake-up feature
4	FRSTE	1	Function reset connection bit. This bit connects/disconnects the USB function reset from the MCU reset.	
			FRSTE = 0	Function reset is not connected to the MCU reset.
			FRSTE = 1	Function reset is connected to the MCU reset.
5	RWUP	0	Device remote wake-up request. This bit is set by the MCU and is cleared automatically.	
			RWUP = 0	Writing a 0 to this bit has no effect.
			RWUP = 1	When the MCU writes a 1, a remote wake-up pulse is generated.
6	RSV	0	Reserved	
7	CONT	0	Connect and Disconnect bit	
			CONT = 0	Upstream port is disconnected. Pullup disabled
			CONT = 1	Upstream port is connected. Pullup enabled

7.5.6.5 VIDSTA: VID/PID Status Register

This register is used to read the value on four external pins. The firmware can use this value to select one of the vendor identification/product identifications (VID/PID) stored in memory. The TUSB3210 supports up to 16 unique VID/PIDs with application code to support different products. This provides a unique opportunity for original equipment manufacturers (OEMs) to have one device to support up to 16 different product lines by using S0–S3 to select VID/PID and behavioral application code for the selected product.

7	6	5	4	3	2	1	0
RSV	RSV	RSV	RSV	S3	S2	S1	S0
R/O	R/O	R/O	R/O	R/O	R/O	R/O	R/O

LEGEND: R/W = Read/Write; R = Read only; -n = value after reset

BIT	NAME	RESET	FUNCTION
3–0	S[3:0]	x	VID/PID selection bits. These bits reflect the status of the external pins as defined by Table 7 ⁽¹⁾ .
7–4	RSV	0	Reserved = 0

(1) A pin tied low is reflected as a 0 and a pin tied high is reflected as a 1.

Table 7. External Pin Mapping to S[3:0] in VIDSTA Register

VIDSTA REGISTER, S[3:0]	PIN		COMMENTS
	NO.	NAME	
S0	58	P3.0	Dual function P3.0 I/O or S0 input
S1	57	P3.1	Dual function P3.1 I/O or S1 input
S2	8	S2	S2-pin is input
S3	9	S3	S3-pin is input

7.5.7 Function Reset and Power-Up Reset Interconnect

Figure 3 represents the logical connection of the USB-function-reset ($\overline{\text{USBR}}$) and power-up-reset ($\overline{\text{RST}}$) pins. The internal RESETE signal is generated from the $\overline{\text{RST}}$ pin ($\overline{\text{PURS}}$ signal) or from the USB-reset ($\overline{\text{USBR}}$ signal). The $\overline{\text{USBR}}$ can be enabled or disabled by the FRSTE bit in the USBCTL register (on power up FRSTE = 0). The internal RESETE is used to reset all registers and logic, with the exception of the USBCTL and MISCTL registers. The USBCTL and MCU configuration registers (MCNFG) are cleared by the $\overline{\text{PURS}}$ signal only.

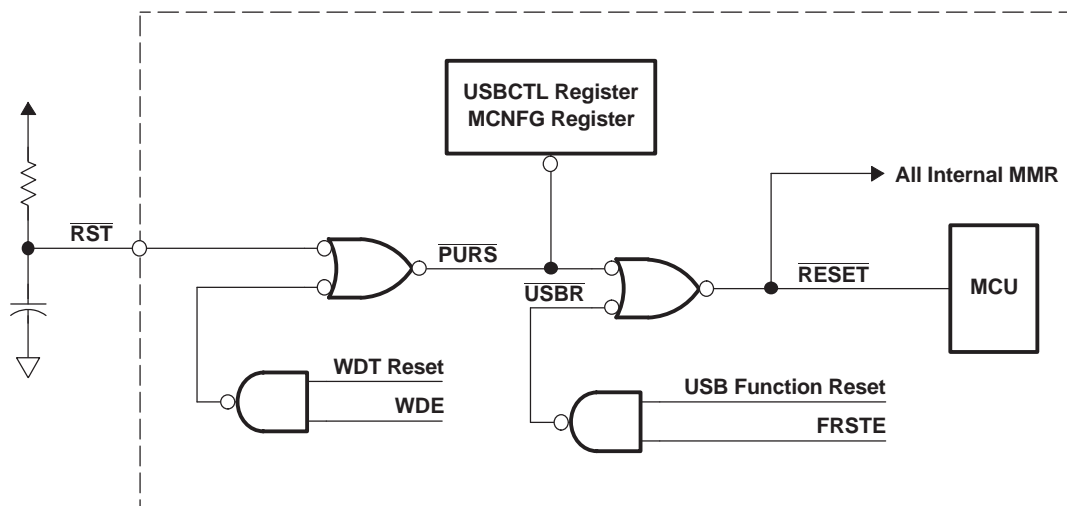

Figure 3. Reset Diagram

7.5.8 Pullup Resistor Connect and Disconnect

After reading firmware into RAM, the TUSB3210 can re-enumerate using the new firmware (no need to physically disconnect and reconnect the cable). Figure 4 shows an equivalent circuit implementation for *Connect* and *Disconnect* from a USB upstream port (also see Figure 11b). When the CONT bit in the USBCTL register is 1, the CMOS driver sources V_{DD} to the pullup resistor (PUR pin) presenting a normal connect condition to the USB hub (high speed). When the CONT bit is 0, the PUR pin is driven low. In this state, the 1.5-k Ω resistor is connected to GND, resulting in device *disconnection* state. The PUR driver is a CMOS driver that can provide $V_{DD} - 0.1$ V minimum at 8 mA of source current.

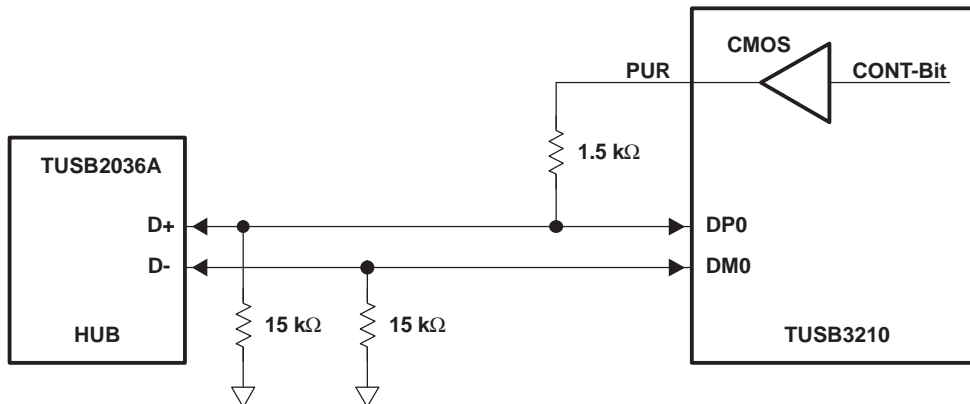

Figure 4. Pullup Resistor Connect and Disconnect Circuit

7.5.9 8052 Interrupt and Status Registers

All seven 8052-standard interrupt sources are preserved (see Table 8). SIE is the standard interrupt enable register, which controls the seven interrupt sources. All the additional interrupt sources are connected together as an OR to generate $\overline{INT0}$. The $\overline{INT0}$ signal is provided to interrupt the MCU (see interrupt connection diagram, Figure 5).

Table 8. 8052 Interrupt Location Map

INTERRUPT SOURCE	DESCRIPTION	START ADDRESS	COMMENTS
ET2	Timer-2 interrupt	002Bh	
ES	UART interrupt	0023h	
ET1	Timer-1 interrupt	001Bh	
EX1	Internal $\overline{INT1}$ or INT1	0013h	Used for P2[7:0] interrupt
ET0	Timer-0 interrupt	000Bh	
$\overline{INT0}$	Internal $\overline{INT0}$	0003h	Used for all internal peripherals
Reset		0000h	

TUSB3210

SLLS466G – FEBRUARY 2001 – REVISED DECEMBER 2015

www.ti.com
7.5.9.1 8052 Standard Interrupt Enable Register

7	6	5	4	3	2	1	0
EA	RSV	ET2	ES	ET1	EX1	ET0	$\overline{\text{INT0}}$
R/W	R/O	R/O	R/W	R/W	R/W	R/W	R/W

LEGEND: R/W = Read/Write; R = Read only; -n = value after reset

BIT	NAME	RESET	FUNCTION	
0	$\overline{\text{INT0}}$	0	Enable or disable interrupt-0	
			$\overline{\text{INT0}} = 0$	Interrupt-0 is disabled.
			$\overline{\text{INT0}} = 1$	Interrupt-0 is enabled.
1	ET0	0	Enable or disable timer-0 interrupt	
			ET0 = 0	Timer-0 interrupt is disabled.
			ET0 = 1	Timer-0 interrupt is enabled.
2	EX1	0	Enable or disable interrupt-1	
			EX1 = 0	Interrupt-1 is disabled.
			EX1 = 1	Interrupt-1 is enabled.
3	ET1	0	Enable or disable timer-1 interrupt	
			ET1 = 0	Timer-1 interrupt is disabled.
			ET1 = 1	Timer-1 interrupt is enabled.
4	ES	0	Enable or disable serial port interrupts	
			ES = 0	Serial port interrupt is disabled.
			ES = 1	Serial port interrupt is enabled.
5	ET2	0	Enable or disable timer-2 interrupt	
			ET2 = 0	Timer-2 interrupt is disabled.
			ET2 = 1	Timer-2 interrupt is enabled.
6	RSV	0	Reserved	
7	EA	0	Enable or disable all interrupts (global disable)	
			EA = 0	Disable all interrupts.
			EA = 1	Each interrupt source is individually controlled.

7.5.9.2 Additional Interrupt Sources

All nonstandard 8052 interrupts (USB, I²C, and so on) are connected as an OR to generate an internal $\overline{\text{INT0}}$. It must be noted that the external INT0 and INT1 are not used. Furthermore, $\overline{\text{INT0}}$ must be programmed as an active-low level interrupt (not edge-triggered). A vector interrupt register is provided to identify all interrupt sources (see vector interrupt register definition, [VECINT: Vector Interrupt Register](#)). Up to 64 interrupt vectors are provided. It is the responsibility of the MCU to read the vector and dispatch the proper interrupt routine.

7.5.9.3 VECINT: Vector Interrupt Register

This register contains a vector value identifying the internal interrupt source that trapped to location 0003h. Writing any value to this register removes the vector and updates the next vector value (if another interrupt is pending). Note that the vector value is offset. Therefore, its value is in increments of two (bit 0 is set to 0). When no interrupt is pending, the vector is set to 00h. [Table 9](#) lists the vector interrupt values. As shown, the interrupt vector is divided into two fields; I[2:0] and G[3:0]. The I-field defines the interrupt source within a group (on a first-come, first-served basis) and the G-field defines the group number. Group G0 is the lowest and G15 is the highest priority.

7	6	5	4	3	2	1	0
G3	G2	G1	G0	I2	I1	I0	RSV
R/W	R/W	R/W	R/W	R/W	R/W	R/W	R/O

LEGEND: R/W = Read/Write; R = Read only; -n = value after reset

BIT	NAME	RESET	FUNCTION
0	RSV	0	Reserved
3–1	I[2:0]	000	This field defines the interrupt source in a given group. See Table 9: Vector Interrupt Values . Bit 0 is always 0; therefore, vector values are offset by two.
7–4	G[3:0]	0000	This field defines the interrupt group. I[2:0] and G[3:0] combine to produce the actual interrupt vector.

Table 9. Vector Interrupt Values

G[3:0] (Hex)	I[2:0] (Hex)	VECTOR (Hex)	INTERRUPT SOURCE
0	0	00	No interrupt
1	0	10	RESERVED
1	1	12	Output endpoint-1
1	2	14	Output endpoint-2
1	3	16	Output endpoint-3
1	4–7	18–1E	RESERVED
2	0	20	RESERVED
2	1	22	Input endpoint-1
2	2	24	Input endpoint-2
2	3	26	Input endpoint-3
2	4–7	28–2E	RESERVED
3	0	30	STPOW packet received
3	1	32	SETUP packet received
3	2	34	PWON interrupt
3	3	36	PWOFF interrupt
3	4	38	RESR interrupt
3	5	3A	SUSR interrupt
3	6	3C	RSTR interrupt
3	7	3E	RESERVED
4	0	40	I ² C TXE interrupt
4	1	42	I ² C RXF interrupt
4	2	44	Input endpoint-0
4	3	46	Output endpoint-0
4	4–7	48–4E	RESERVED
5–F	X	90–FE	RESERVED

7.5.9.4 Logical Interrupt Connection Diagram ($\overline{INT0}$)

Figure 5 represents the logical connection of the interrupt sources and the relation of the logical connection with $\overline{INT0}$. The priority encoder generates an 8-bit vector, corresponding to 64 interrupt sources (not all are used). The interrupt priorities are hard wired. Vector 46h is the highest and 12h is the lowest. Table 9 lists the interrupt source for each valid interrupt vector.

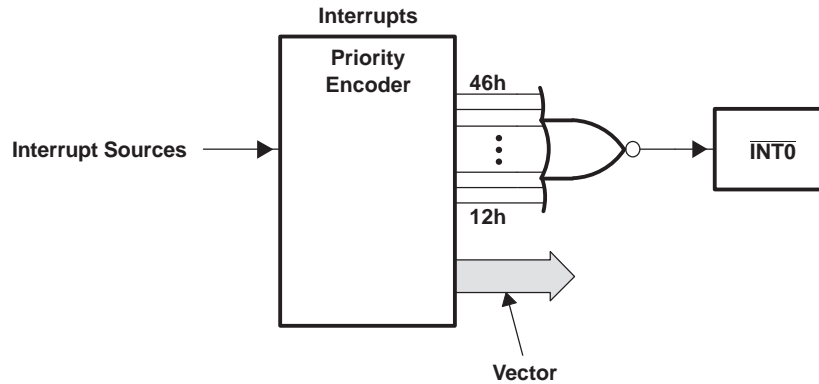

Figure 5. Internal Vector Interrupt ($\overline{INT0}$)

7.5.9.5 P2[7:0], P3.3 Interrupt ($\overline{INT1}$)

Figure 6 illustrates the conceptual port-2 interrupt. All port-2 input signals are connected in a logical OR to generate the $\overline{INT1}$ interrupt. Note that the inputs are active-low and $\overline{INT1}$ is programmed as a level-triggered interrupt. In addition, $\overline{INT1}$ is connected to the suspend/resume logic for remote wake-up support. As illustrated, the XINT bit in the MCU configuration register (MCNFG) is used to select the EX1 interrupt source. When XINT = 0, P3.3 is the source, and when XINT = 1, P2[7:0] is the source. The programmable delay is determined by the setting of I[3:0] in the INTCFG register.

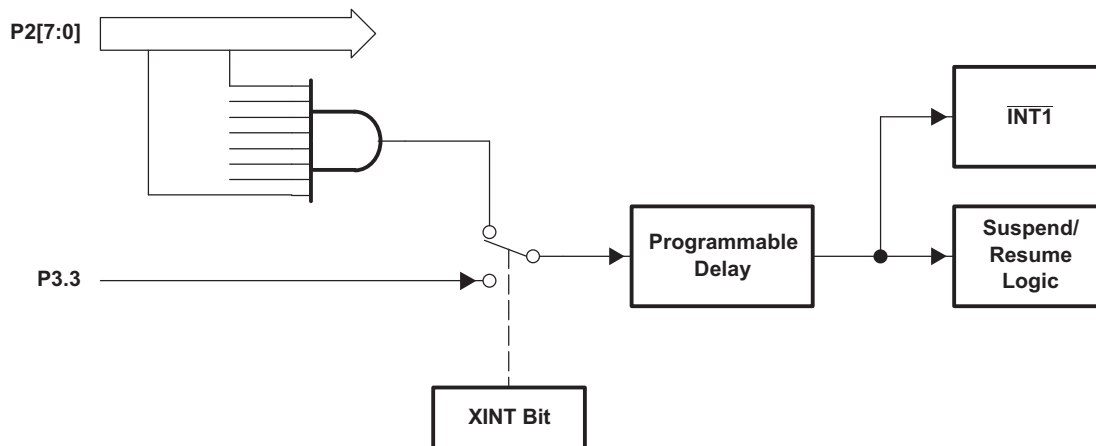

Figure 6. P2[7:0], P3.3 Input Port Interrupt Generation

7.5.10 I²C Registers

The TUSB3210 device only supports a master-slave relationship; therefore, it does not support bus arbitration.

7.5.10.1 I2CSTA: I²C Status and Control Register

This register is used to control the stop condition for read and write operations. In addition, it provides transmitter and receiver handshake signals with their respective interrupt enable bits.

7	6	5	4	3	2	1	0
RXF	RIE	ERR	1/4	TXE	TIE	SRD	SWR
R/C	R/W	R/C	R/W	R/C	R/W	R/W	R/W

LEGEND: R/W = Read/Write; R = Read only; -n = value after reset

BIT	NAME	RESET	FUNCTION	
0	SWR	0	Stop write condition. This bit defines whether the I ² C controller generates a stop condition when data from the I2CDAO register is transmitted to an external device.	
			SWR = 0	Stop condition is not generated when data from the I2CDAO register is shifted out to an external device.
			SWR = 1	Stop condition is generated when data from the I2CDAO register is shifted out to an external device.
1	SRD	0	Stop read condition. This bit defines whether the I ² C controller generates a stop condition when data is received and loaded into I2CDAI register.	
			SRD = 0	Stop condition is not generated when data from SDA line is shifted into the I2CDAI register.
			SRD = 1	Stop condition is generated when data from SDA line is shifted into the I2CDAI register.
2	TIE	0	I ² C transmitter empty interrupt enable	
			TIE = 0	Interrupt disabled
			TIE = 1	Interrupt enabled
3	TXE	1	I ² C transmitter empty. This bit indicates that data can be written to the transmitter. It can be used for polling or it can generate an interrupt.	
			TXE = 0	Transmitter is full. This bit is cleared when the MCU writes a byte to the I2CDAO register.
			TXE = 1	Transmitter is empty. The I ² C controller sets this bit when the content of the I2CDAO register is copied to the SDA shift register.
4	1/4	0	Bus speed selection	
			1/4 = 0	100-kHz bus speed
			1/4 = 1	400-kHz bus speed
5	ERR	0	Bus error condition. This bit is set by the hardware when the device does not respond. It is cleared by the MCU.	
			ERR = 0	No bus error
			ERR = 1	Bus error condition has been detected. Clears when the MCU writes a 1. Writing a 0 has no effect.
6	RIE	0	I ² C receiver ready interrupt enable	
			RIE = 0	Interrupt disabled
			RIE = 1	Interrupt enabled
7	RXF	0	I ² C receiver full. This bit indicates that the receiver contains new data. It can be used for polling or it can generate an interrupt.	
			RXF = 0	Receiver is empty. This bit is cleared when the MCU reads the I2CDAI register.
			RXF = 1	Receiver contains new data. This bit is set by the I ² C controller when the received serial data has been loaded into the I2CDAI register.

7.5.10.2 I2CADR: I²C Address Register

This register holds the device address and the read/write command bit.

7	6	5	4	3	2	1	0
A6	A5	A4	A3	A2	A1	A0	R/W
R/W	R/W	R/W	R/W	R/W	R/W	R/W	R/W

LEGEND: R/W = Read/Write; R = Read only; -n = value after reset

BIT	NAME	RESET	FUNCTION
0	R/W	0	Read/write command bit
			R/W = 0 Write operation
			R/W = 1 Read operation
7–1	A[6:0]	000 0000	Seven address bits for device addressing

7.5.10.3 I2CDAI: I²C Data-Input Register

This register holds the received data from an external device.

7	6	5	4	3	2	1	0
D7	D6	D5	D4	D3	D2	D1	D0
R/O	R/O	R/O	R/O	R/O	R/O	R/O	R/O

LEGEND: R/W = Read/Write; R = Read only; -n = value after reset

BIT	NAME	RESET	FUNCTION
7–0	D[7:0]	0	8-bit input data from an I ² C device

7.5.10.4 I2CDAO: I²C Data-Output Register

This register holds the data to be transmitted to an external device. Writing to this register starts the transfer on the SDA line.

7	6	5	4	3	2	1	0
D7	D6	D5	D4	D3	D2	D1	D0
R/W	R/W	R/W	R/W	R/W	R/W	R/W	R/W

LEGEND: R/W = Read/Write; R = Read only; -n = value after reset

BIT	NAME	RESET	FUNCTION
7–0	D[7:0]	0	8-bit output data to an I ² C device

7.5.11 Read/Write Operations

7.5.11.1 Read Operation (Serial EEPROM)

A serial read requires a *dummy* byte write sequence to load in the 16-bit data word address. When the device address word and data address word are clocked out and acknowledged by the device, the MCU starts a current address sequence. The following describes the sequence of events to accomplish this transaction:

Device Address + EEPROM [High Byte]

1. The MCU sets I2CSTA[SRD] = 0. This prevents the I²C controller from generating a stop condition after the content of the I2CDAI register is received.
2. The MCU sets I2CSTA[SWR] = 0. This prevents the I²C controller from generating a stop condition after the content of the I2CDAO register is transmitted.
3. The MCU writes the device address (R/W bit = 0) to the I2CADR register (write operation).
4. The MCU writes the high byte of the EEPROM address into the I2CDAO register, starting the transfer on the SDA line.
5. The TXE bit in I2CSTA is cleared, indicating busy.
6. The content of the I2CADR register is transmitted to the EEPROM (preceded by start condition on SDA).
7. The content of the I2CDAO register is transmitted to the EEPROM (EEPROM address).
8. The TXE bit in I2CSTA is set, and interrupts the MCU, indicating that the I2CDAO register has been transmitted.
9. No stop condition is generated.

EEPROM [Low Byte]

1. The MCU writes the low byte of the EEPROM address into the I2CDAO register.
2. The TXE bit in I2CSTA is cleared, indicating busy.
3. The content of the I2CDAO register is transmitted to the device (EEPROM address).
4. The TXE bit in I2CSTA is set, and interrupts the MCU, indicating that the I2CDAO register has been transmitted.
5. This completes the *dummy* write operation. At this point, the EEPROM address is set and the MCU can do a single or a sequential read operation.

7.5.11.2 Current Address Read Operation

When the EEPROM address is set, the MCU can read a single byte by executing the following steps:

1. The MCU sets I2CSTA[SRD] = 1, forcing the I²C controller to generate a stop condition after the I2CDAI register is received.
2. The MCU writes the device address (R/W bit = 1) to the I2CADR register (read operation).
3. The MCU writes a dummy byte to the I2CDAO register, starting the transfer on the SDA line.
4. The RXF bit in I2CSTA is cleared.
5. The content of the I2CADR register is transmitted to the device, preceded by a start condition on SDA.
6. Data from the EEPROM is latched into the I2CDAI register (stop condition is transmitted).
7. The RXF bit in I2CSTA is set, and interrupts the MCU, indicating that the data is available.
8. The MCU reads the I2CDAI register. This clears the RXF bit (I2CSTA[RXF] = 0).

7.5.11.3 Sequential Read Operation

When the EEPROM address is set, the MCU can execute a sequential read operation by executing the following steps:

NOTE

This example illustrates a 32-byte sequential read.

1. Device Address
 - (a) The MCU sets I2CSTA[SRD] = 0. This prevents the I²C controller from generating a stop condition after the I2CDAI register is received.
 - (b) The MCU writes the device address (R/W bit = 1) to the I2CADR register (read operation).
 - (c) The MCU writes a dummy byte to the I2CDAO register, starting the transfer on the SDA line.
 - (d) The RXF bit in I2CSTA is cleared.
 - (e) The content of the I2CADR register is transmitted to the device (preceded by a start condition on SDA).
2. N-Byte Read (31 bytes)
 - (a) Data from the device is latched into the I2CDAI register (stop condition is not transmitted).
 - (b) The RXF bit in I2CSTA is set and interrupts the MCU, indicating that data is available.
 - (c) The MCU reads the I2CDAI register, clearing the RXF bit (I2CSTA[RXF] = 0).
 - (d) This operation repeats 31 times.
3. Last-Byte Read (byte no. 32)
 - (a) The MCU sets I2CSTA[SRD] = 1. This forces the I²C controller to generate a stop condition after the I2CDAI register is received.
 - (b) Data from the device is latched into the I2CDAI register (stop condition is transmitted).
 - (c) The RXF bit in I2CSTA is set and interrupts the MCU, indicating that data is available.
 - (d) The MCU reads the I2CDAI register, clearing the RXF bit (I2CSTA[RXF] = 0).

7.5.11.4 Write Operation (Serial EEPROM)

The byte write operation involves three phases: 1) device address + EEPROM [high byte] phase, 2) EEPROM [low byte] phase, and 3) EEPROM [DATA]. The following describes the sequence of events to accomplish the byte write transaction:

Device Address + EEPROM [High Byte]

1. The MCU sets I2CSTA[SWR] = 0. This prevents the I²C controller from generating a stop condition after the content of the I2CDAO register is transmitted.
2. The MCU writes the device address (R/W bit = 0) to the I2CADR register (write operation).
3. The MCU writes the high byte of the EEPROM address into the I2CDAO register, starting the transfer on the SDA line.
4. The TXE bit in I2CSTA is cleared, indicating busy.
5. The content of the I2CADR register is transmitted to the device (preceded by a start condition on SDA).
6. The content of the I2CDAO register is transmitted to the device (EEPROM high-address).
7. The TXE bit in I2CSTA is set and interrupts the MCU, indicating that the I2CDAO register has been transmitted.

EEPROM [Low Byte]

1. The MCU writes the low byte of the EEPROM address into the I2CDAO register.
2. The TXE bit in I2CSTA is cleared, indicating busy.
3. The content of the I2CDAO register is transmitted to the device (EEPROM address).
4. The TXE bit in I2CSTA is set and interrupts the MCU, indicating that the I2CDAO register has been transmitted.

EEPROM [DATA]

1. The MCU sets I2CSTA[SWR] = 1. This forces the I²C controller to generate a stop condition after the content of the I2CDAO register is transmitted.
2. The MCU writes the DATA to be written to the EEPROM into the I2CDAO register.
3. The TXE bit in I2CSTA is cleared, indicating busy.
4. The content of the I2CDAO register is transmitted to the device (EEPROM data).
5. The TXE bit in I2CSTA is set and interrupts the MCU, indicating that the I2CDAO register has been transmitted.
6. The I²C controller generates a stop condition after the content of the I2CDAO register is transmitted.

7.5.11.5 Page Write Operation

The page write operation is initiated the same way as byte write, with the exception that a stop condition is not generated after the first EEPROM [DATA] is transmitted. The following describes the sequence of writing 32 bytes in page mode:

Device Address + EEPROM [High Byte]

1. The MCU sets I2CSTA[SWR] = 0. This prevents the I²C controller from generating a stop condition after the content of the I2CDAO register is transmitted.
2. The MCU writes the device address (R/W bit = 0) to the I2CADR register (write operation).
3. The MCU writes the high byte of the EEPROM address into the I2CDAO register.
4. The TXE bit in I2CSTA is cleared, indicating busy.
5. The content of the I2CADR register is transmitted to the device (preceded by a start condition on SDA).
6. The content of the I2CDAO register is transmitted to the device (EEPROM address).
7. The TXE bit in I2CSTA is set and interrupts the MCU, indicating that the I2CDAO register has been sent.

EEPROM [Low Byte]

1. The MCU writes the low byte of the EEPROM address into the I2CDAO register.
2. The TXE bit in I2CSTA is cleared, indicating busy.
3. The content of the I2CDAO register is transmitted to the device (EEPROM address).
4. The TXE bit in I2CSTA is set and interrupts the MCU, indicating that the I2CDAO register has been sent.

31 Bytes EEPROM [DATA]

1. The MCU writes the DATA to be written to the EEPROM into the I2CDAO register.
2. The TXE bit in I2CSTA is cleared, indicating busy.
3. The content of the I2CDAO register is transmitted to the device (EEPROM data).
4. The TXE bit in I2CSTA is set and interrupts the MCU, indicating that the I2CDAO register has been sent.
5. This operation repeats 31 times.

Last Byte EEPROM [DATA]

1. The MCU sets I2CSTA[SWR] = 1. This forces the I²C controller to generate a stop condition after the content of the I2CDAO register is transmitted.
2. The MCU writes the last DATA byte to be written to the EEPROM into the I2CDAO register.
3. The TXE bit in I2CSTA is cleared, indicating busy.
4. The content of the I2CDAO register is transmitted to the EEPROM (EEPROM data).
5. The TXE bit in I2CSTA is set and interrupts the MCU, indicating that the I2CDAO register has been sent.
6. The I²C controller generates a stop condition after the content of the I2CDAO register is transmitted, terminating the 32-byte page write operation.

8 Application and Implementation

NOTE

Information in the following applications sections is not part of the TI component specification, and TI does not warrant its accuracy or completeness. TI's customers are responsible for determining suitability of components for their purposes. Customers should validate and test their design implementation to confirm system functionality.

8.1 Application Information

8.1.1 Reset Timing

There are three requirements for the reset signal timing. First, the minimum reset pulse duration is 100 μs . At power up, this time is measured from the time the power ramps up to 90% of the nominal V_{CC} until the reset signal exceeds 1.2 V. The second requirement is that the clock must be valid during the last 60 μs of the reset window. The third requirement is that, according to the USB specification, the device must be ready to respond to the host within 100 ms. This means that within the 100-ms window, the device must come out of reset, load any pertinent data from the I²C EEPROM device, and transfer execution to the application firmware if any is present. Because the latter two events can require significant time, the amount of that can change from system to system, TI recommends having the device come out of reset within 30 ms, leaving 70 ms for the other events to complete. This means the reset signal should rise to 1.8 V within 30 ms.

These requirements are depicted in Figure 7. Notice that when using a 12-MHz crystal or the 48-MHz oscillator, the clock signal may take several milliseconds to ramp up and become valid after power up. Therefore, the reset window may need to be elongated up to 10 ms or more to ensure that there is a 60- μs overlap with a valid clock.

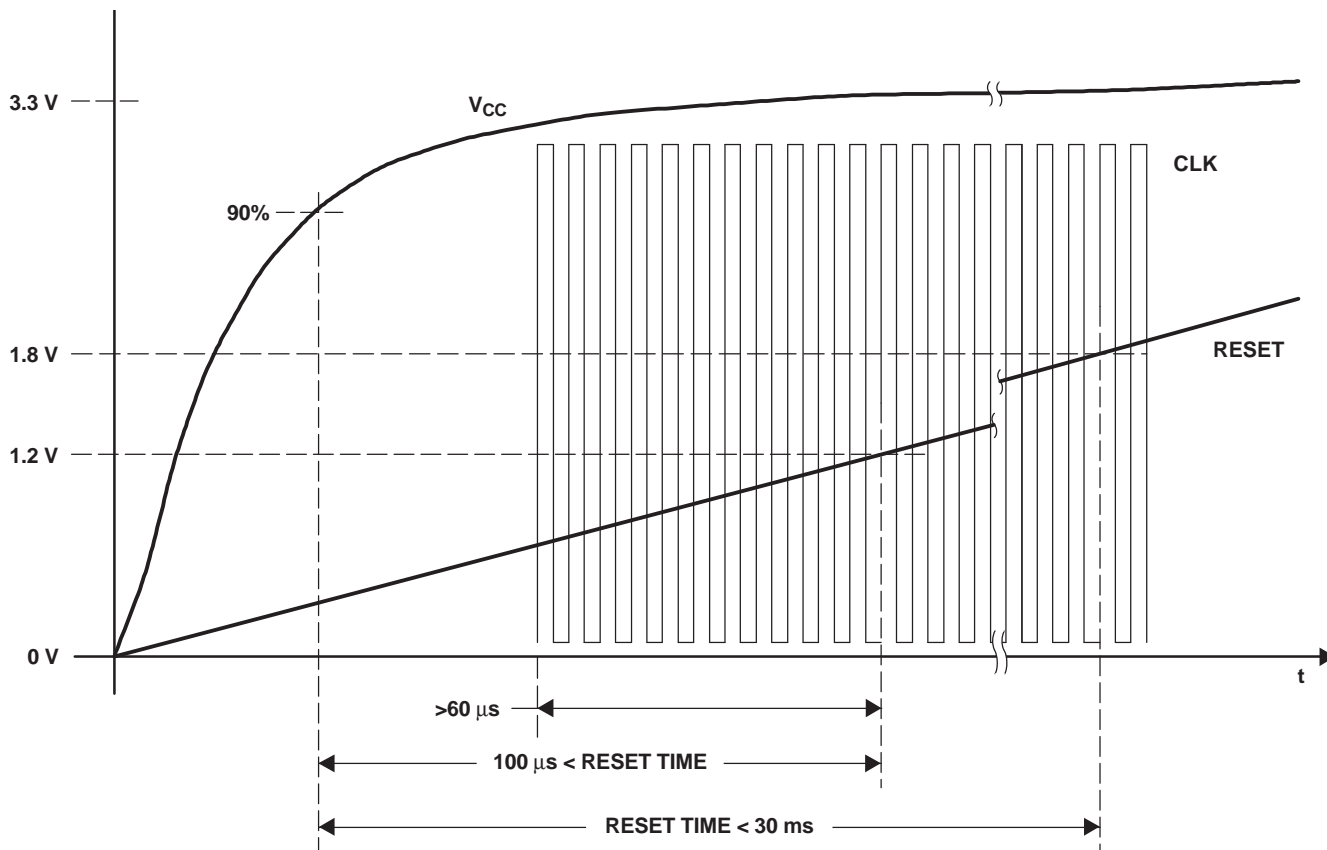

Figure 7. Reset Timing

Application Information (continued)

8.1.2 Generic EVM

The TUSB3210 generic EVM is designed for use with a personal computer running a USB-enabled operating system. The PC must be USB 1.1 specification compliant, which implies that the BIOS, chipsets, and operating system are all USB 1.1 specification compliant. If the BIOS is not specification compliant, the system may not boot up when USB devices are connected at power up, and the EVM may not function.

NOTE

An AC-DC power supply adapter is optional equipment (but included), because the EVM can function in either bus-powered mode or self-powered mode.

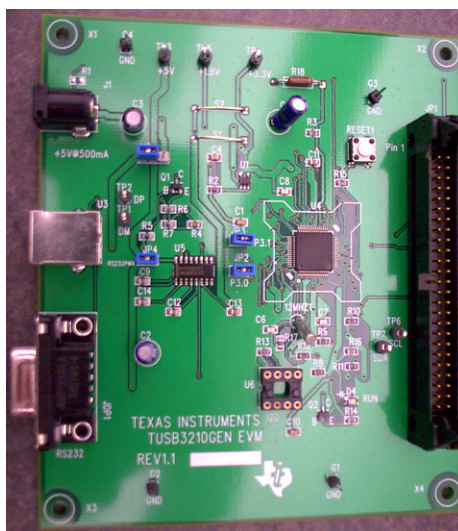

Figure 8. Generic EVM

8.2 Typical Applications

8.2.1 Example LED Connection

Figure 9 illustrates the port-3 pins that are assigned to drive the four example LEDs. For the connection example shown, P3[5:2] can sink up to 8 mA each (open-drain outputs). Figure 7 illustrates the downstream connection (only one port shown).

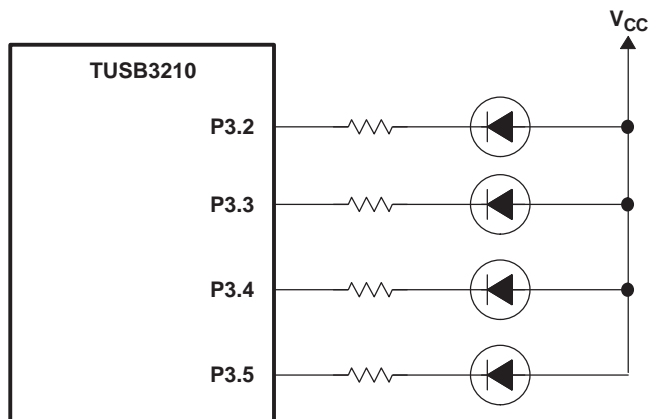

Figure 9. Example LED Connection

Typical Applications (continued)

8.2.1.1 Design Requirements

Table 10 lists the design requirements for the LED connection application.

Table 10. Design Requirements

DESIGN PARAMETER	VALUE
VCC Supply	3.3 V
VDD1/8	1.8 V
Upstream port USB (FS)	FS
XTAL	12 MHz

8.2.1.2 Detailed Design Procedure

8.2.1.2.1 Partial Connection Bus Power Mode

Figure 10 illustrates the partial connection bus power mode.

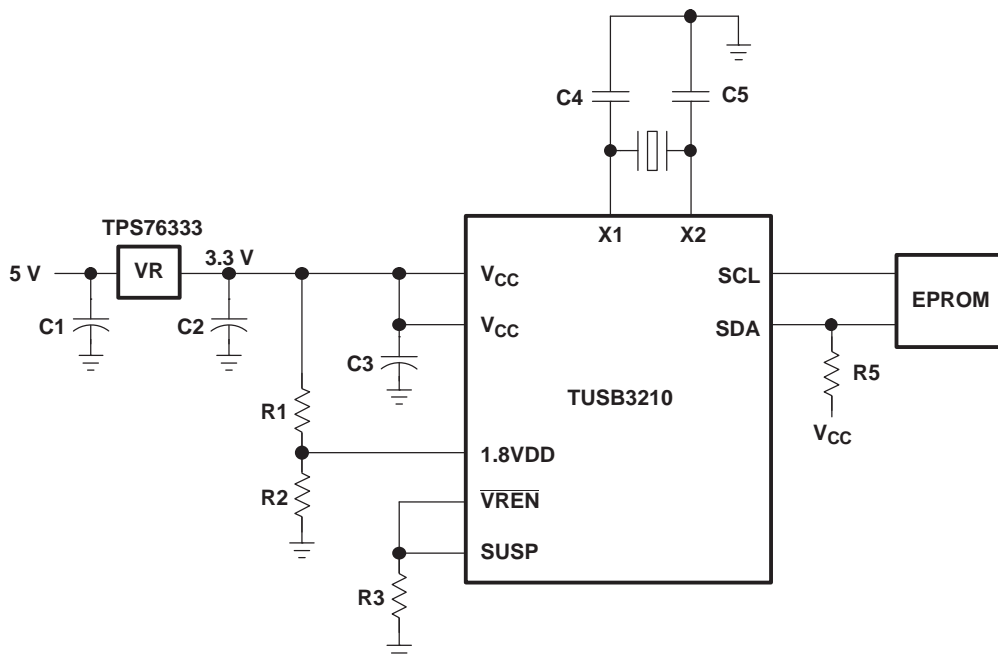

Figure 10. Partial Connection Bus Power Mode

8.2.1.2.2 Upstream Connection

Figure 11 shows the USB upstream connection.

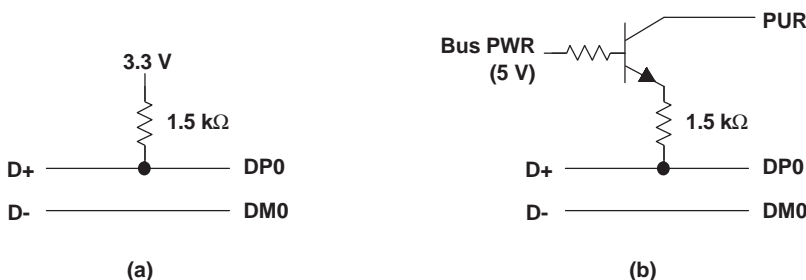

Figure 11. Upstream Connection
(a) Non-Switching Power Mode (b) Switching Power Mode

TUSB3210

SLLS466G – FEBRUARY 2001 – REVISED DECEMBER 2015

www.ti.com

8.2.1.2.3 Crystal Implementation

Figure 12 shows the crystal implementation setup.

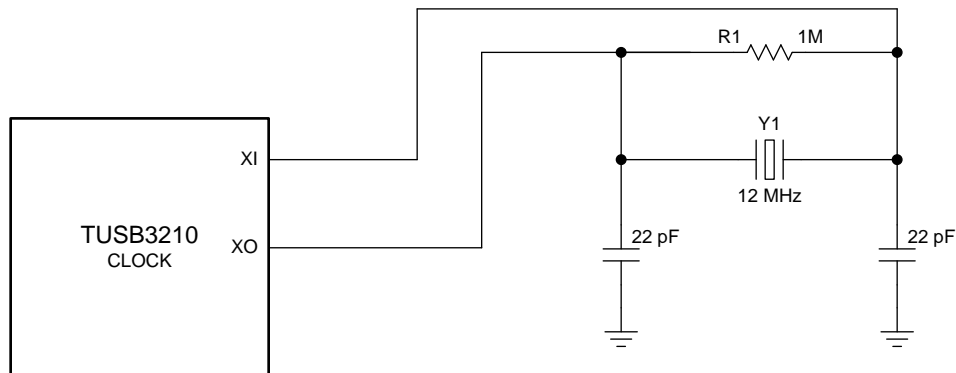

Figure 12. Crystal Implementation Diagram

8.2.1.2.4 TUSB3210 Power Implementation

Figure 13 shows the power implementation for the TUB3210 device.

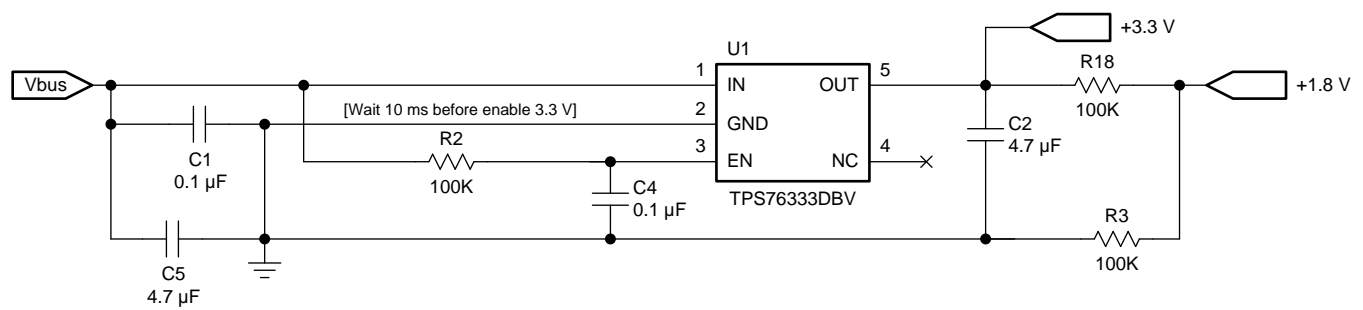

Figure 13. Power Implementation Diagram

9 Power Supply Recommendations

The TUSB3210 device requires a 3.3-V digital power source.

The 3.3-V terminals are named VDD33 and supply power to most of the input and output cells. VDD33 supplies must have 0.1- μ F bypass capacitors to VSS (ground) to ensure proper operation. One capacitor per power terminal is sufficient and must be placed as close to the terminal as possible to minimize trace length. TI recommends placing smaller value capacitors (like 0.01- μ F) on the digital supply terminals.

When placing and connecting all bypass capacitors, follow high-speed board design rules.

10 Layout

10.1 Layout Guidelines

A primary concern when designing a system is accommodating and isolating high-speed signals. As high-speed signals are most likely to impact or be impacted by other signals, they must be laid out early (preferably first) in the PCB design process to ensure that prescribed routing rules can be followed. Table 11 outlines the signals requiring the most attention in a USB layout.

Table 11. Critical Signals

SIGNAL NAME	DESCRIPTION
DP	USB 2.0 differential pair, positive
DM	USB 2.0 differential pair, negative
SSTXP	SuperSpeed differential pair, TX, positive
SSTXN	SuperSpeed differential pair, TX, negative
SSRXP	SuperSpeed differential pair, RX, positive
SSRXN	SuperSpeed differential pair, RX, negative

10.1.1 Differential Signal Spacing

To minimize crosstalk in USB implementations, the spacing between the signal pairs must be a minimum of 5 times the width of the trace. This spacing is the 5-W rule. Also, maintain a minimum keep-out area of 30 mils to any other signal throughout the length of the trace. Where the USB differential pair abuts a clock or a periodic signal, increase this keep-out to a minimum of 50 mils to ensure proper isolation.

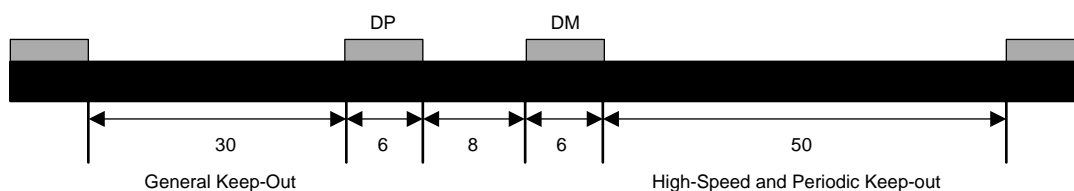

Figure 14. USB2 Differential Signal Spacing (mils)

10.1.2 Differential Signal Rules

- Do not place probe or test points on any USB differential signal.
- Do not route USB traces under or near crystals, oscillators, clock signal generators, switching power regulators, mounting holes, magnetic devices, or ICs that use or duplicate clock signals.
- After BGA breakout, keep USB differential signals clear of the SoC because high current transients produced during internal state transitions can be difficult to filter out.
- When possible, route the USB differential pair signals on the top or bottom layer of the PCB with an adjacent GND layer. TI does not recommend stripline routing of the USB differential signals.
- Ensure that USB differential signals are routed ≥ 90 mils from the edge of the reference plane.
- Ensure that USB differential signals are routed at least $1.5W$ (calculated trace-width $\times 1.5$) away from voids in the reference plane. This rule does not apply where SMD pads on the USB differential signals are voided.
- Maintain constant trace width after the SoC BGA escape to avoid impedance mismatches in the transmission lines.
- Maximize differential pair-to-pair spacing when possible.

For specific USB 2.0 layout guidelines, see the *USB Layout Guidelines* Application Report ([SPRAAR7](#)).

10.2 Layout Example

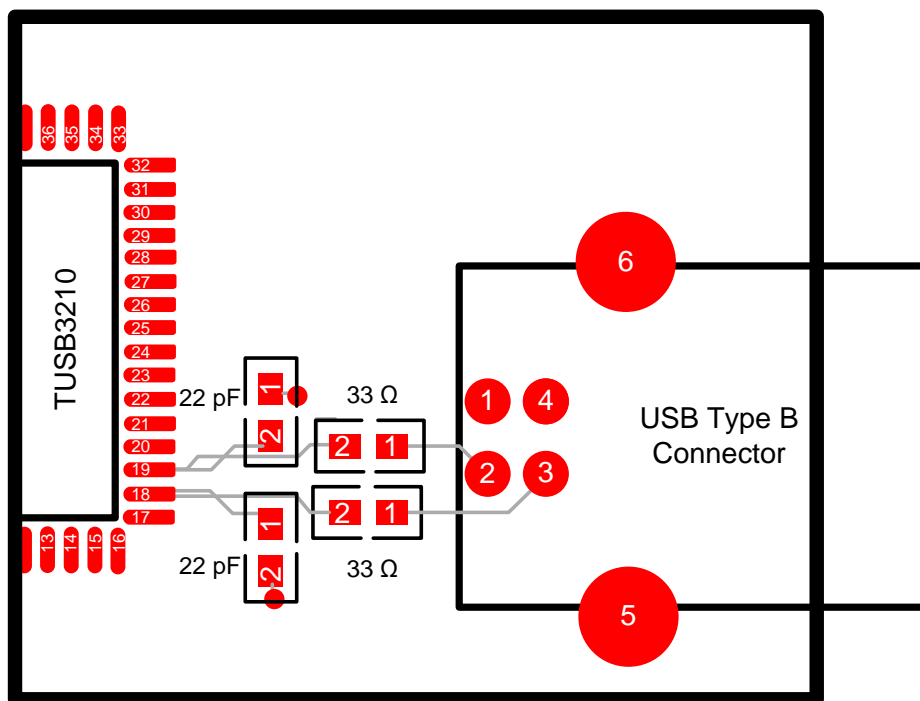

Figure 15. Layout Example for TUSB3210

11 Device and Documentation Support

11.1 Documentation Support

11.1.1 Related Documentation

For related documentation see the following:

[SPRAAR7](#) *USB Layout Guidelines Application Report*

11.2 Community Resources

The following links connect to TI community resources. Linked contents are provided "AS IS" by the respective contributors. They do not constitute TI specifications and do not necessarily reflect TI's views; see TI's [Terms of Use](#).

[TI E2E™ Online Community](#) *TI's Engineer-to-Engineer (E2E) Community*. Created to foster collaboration among engineers. At [e2e.ti.com](#), you can ask questions, share knowledge, explore ideas and help solve problems with fellow engineers.

[Design Support](#) *TI's Design Support* Quickly find helpful E2E forums along with design support tools and contact information for technical support.

11.3 Trademarks

E2E is a trademark of Texas Instruments.
All other trademarks are the property of their respective owners.

11.4 Electrostatic Discharge Caution



These devices have limited built-in ESD protection. The leads should be shorted together or the device placed in conductive foam during storage or handling to prevent electrostatic damage to the MOS gates.

11.5 Glossary

[SLYZ022](#) — *TI Glossary*.

This glossary lists and explains terms, acronyms, and definitions.

12 Mechanical, Packaging, and Orderable Information

The following pages include mechanical, packaging, and orderable information. This information is the most current data available for the designated devices. This data is subject to change without notice and revision of this document. For browser-based versions of this data sheet, refer to the left-hand navigation.

PACKAGING INFORMATION

Orderable Device	Status (1)	Package Type	Package Drawing	Pins	Package Qty	Eco Plan (2)	Lead/Ball Finish (6)	MSL Peak Temp (3)	Op Temp (°C)	Device Marking (4/5)	Samples
TUSB3210PM	LIFEBUY	LQFP	PM	64		TBD	Call TI	Call TI	0 to 70	TUSB3210PM	
TUSB3210PMG4	LIFEBUY	LQFP	PM	64		TBD	Call TI	Call TI	0 to 70	TUSB3210PM	

(1) The marketing status values are defined as follows:

ACTIVE: Product device recommended for new designs.

LIFEBUY: TI has announced that the device will be discontinued, and a lifetime-buy period is in effect.

NRND: Not recommended for new designs. Device is in production to support existing customers, but TI does not recommend using this part in a new design.

PREVIEW: Device has been announced but is not in production. Samples may or may not be available.

OBSOLETE: TI has discontinued the production of the device.

(2) **RoHS:** TI defines "RoHS" to mean semiconductor products that are compliant with the current EU RoHS requirements for all 10 RoHS substances, including the requirement that RoHS substance do not exceed 0.1% by weight in homogeneous materials. Where designed to be soldered at high temperatures, "RoHS" products are suitable for use in specified lead-free processes. TI may reference these types of products as "Pb-Free".

RoHS Exempt: TI defines "RoHS Exempt" to mean products that contain lead but are compliant with EU RoHS pursuant to a specific EU RoHS exemption.

Green: TI defines "Green" to mean the content of Chlorine (Cl) and Bromine (Br) based flame retardants meet JS709B low halogen requirements of <=1000ppm threshold. Antimony trioxide based flame retardants must also meet the <=1000ppm threshold requirement.

(3) MSL, Peak Temp. - The Moisture Sensitivity Level rating according to the JEDEC industry standard classifications, and peak solder temperature.

(4) There may be additional marking, which relates to the logo, the lot trace code information, or the environmental category on the device.

(5) Multiple Device Markings will be inside parentheses. Only one Device Marking contained in parentheses and separated by a "~" will appear on a device. If a line is indented then it is a continuation of the previous line and the two combined represent the entire Device Marking for that device.

(6) Lead/Ball Finish - Orderable Devices may have multiple material finish options. Finish options are separated by a vertical ruled line. Lead/Ball Finish values may wrap to two lines if the finish value exceeds the maximum column width.

Important Information and Disclaimer: The information provided on this page represents TI's knowledge and belief as of the date that it is provided. TI bases its knowledge and belief on information provided by third parties, and makes no representation or warranty as to the accuracy of such information. Efforts are underway to better integrate information from third parties. TI has taken and continues to take reasonable steps to provide representative and accurate information but may not have conducted destructive testing or chemical analysis on incoming materials and chemicals. TI and TI suppliers consider certain information to be proprietary, and thus CAS numbers and other limited information may not be available for release.

In no event shall TI's liability arising out of such information exceed the total purchase price of the TI part(s) at issue in this document sold by TI to Customer on an annual basis.

PM (S-PQFP-G64)

PLASTIC QUAD FLATPACK

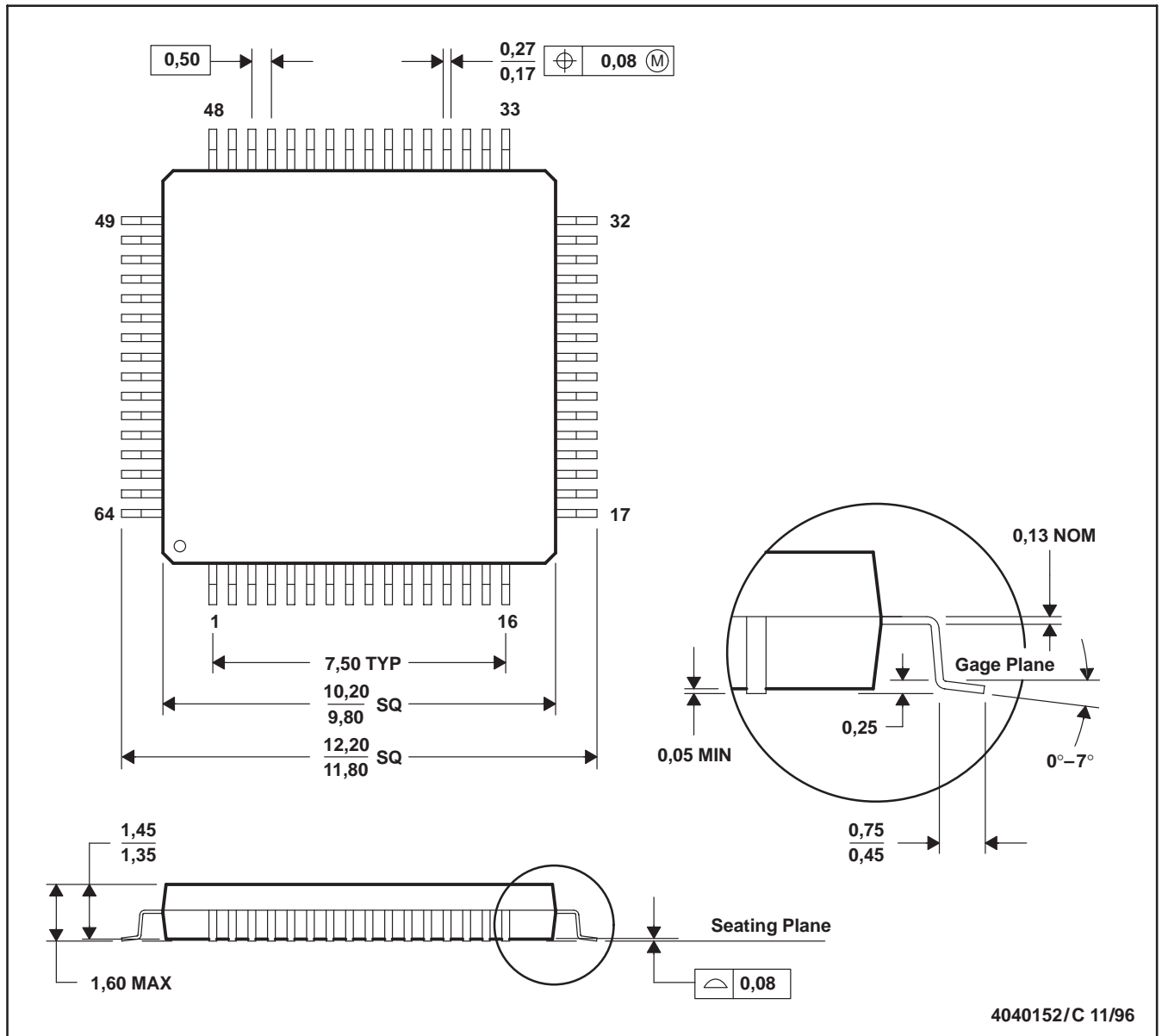

- NOTES:
- A. All linear dimensions are in millimeters.
 - B. This drawing is subject to change without notice.
 - C. Falls within JEDEC MS-026
 - D. May also be thermally enhanced plastic with leads connected to the die pads.

IMPORTANT NOTICE AND DISCLAIMER

TI PROVIDES TECHNICAL AND RELIABILITY DATA (INCLUDING DATASHEETS), DESIGN RESOURCES (INCLUDING REFERENCE DESIGNS), APPLICATION OR OTHER DESIGN ADVICE, WEB TOOLS, SAFETY INFORMATION, AND OTHER RESOURCES "AS IS" AND WITH ALL FAULTS, AND DISCLAIMS ALL WARRANTIES, EXPRESS AND IMPLIED, INCLUDING WITHOUT LIMITATION ANY IMPLIED WARRANTIES OF MERCHANTABILITY, FITNESS FOR A PARTICULAR PURPOSE OR NON-INFRINGEMENT OF THIRD PARTY INTELLECTUAL PROPERTY RIGHTS.

These resources are intended for skilled developers designing with TI products. You are solely responsible for (1) selecting the appropriate TI products for your application, (2) designing, validating and testing your application, and (3) ensuring your application meets applicable standards, and any other safety, security, or other requirements. These resources are subject to change without notice. TI grants you permission to use these resources only for development of an application that uses the TI products described in the resource. Other reproduction and display of these resources is prohibited. No license is granted to any other TI intellectual property right or to any third party intellectual property right. TI disclaims responsibility for, and you will fully indemnify TI and its representatives against, any claims, damages, costs, losses, and liabilities arising out of your use of these resources.

TI's products are provided subject to TI's Terms of Sale (www.ti.com/legal/termsofsale.html) or other applicable terms available either on ti.com or provided in conjunction with such TI products. TI's provision of these resources does not expand or otherwise alter TI's applicable warranties or warranty disclaimers for TI products.

Mailing Address: Texas Instruments, Post Office Box 655303, Dallas, Texas 75265
Copyright © 2019, Texas Instruments Incorporated

Looking for pricing, stock, or lifecycle information?

Click below to explore more details on WIN SOURCE:

 [View TUSB3210PM](#) on WIN SOURCE

 [Texas Instruments](#) Information

Optimize Your Supply Chain with WIN SOURCE Solutions

-  Global Sourcing Solution
-  Obsolete Management
-  Cost Control Management
-  Shortage Management
-  Alternative Solution
-  Excess Inventory Management