



**THE DATASHEET OF
950201AFLF**



Programmable Timing Control Hub™ for P4™

ICS950201

Recommended Application:

CK-408 clock for Intel® 845 chipset with P4 processor.

Output Features:

- 3 Differential CPU Clock Pairs @ 3.3V
- 7 PCI (3.3V) @ 33.3MHz
- 3 PCI_F (3.3V) @ 33.3MHz
- 1 USB (3.3V) @ 48MHz
- 1 DOT (3.3V) @ 48MHz
- 1 REF (3.3V) @ 14.318MHz
- 5 3V66 (3.3V) @ 66.6MHz
- 1 VCH/3V66 (3.3V) @ 48MHz or 66.6MHz

Features:

- Supports spread spectrum modulation, down spread 0 to -0.5%.
- Efficient power management scheme through PD#, CPU_STOP# and PCI_STOP#.
- Uses external 14.318MHz crystal
- Stop clocks and functional control available through I²C interface.

Key Specifications:

- CPU Output Jitter <150ps
- 3V66 Output Jitter <250ps
- CPU Output Skew <100ps, programmable over 800 ps with groups CPU0,1 and CPU2.

Frequency Table

| FS2 | FS1 | FS0 | CPU (MHz) | 3V66 (MHz) | 66Buff[2:0] 3V66[4:2] (MHz) | PCI_F PCI (MHz) |
|-----|-----|-----|-----------|------------|-----------------------------|-----------------|
| 0 | 0 | 0 | 66.66 | 66.66 | 66.66 | 33.33 |
| 0 | 0 | 1 | 100.00 | 66.66 | 66.66 | 33.33 |
| 0 | 1 | 0 | 200.00 | 66.66 | 66.66 | 33.33 |
| 0 | 1 | 1 | 133.33 | 66.66 | 66.66 | 33.33 |
| Mid | 0 | 0 | Tristate | Tristate | Tristate | Tristate |
| Mid | 0 | 1 | TCLK/2 | TCLK/4 | TCLK/4 | TCLK/8 |
| Mid | 1 | 0 | Reserved | Reserved | Reserved | Reserved |
| Mid | 1 | 1 | Reserved | Reserved | Reserved | Reserved |

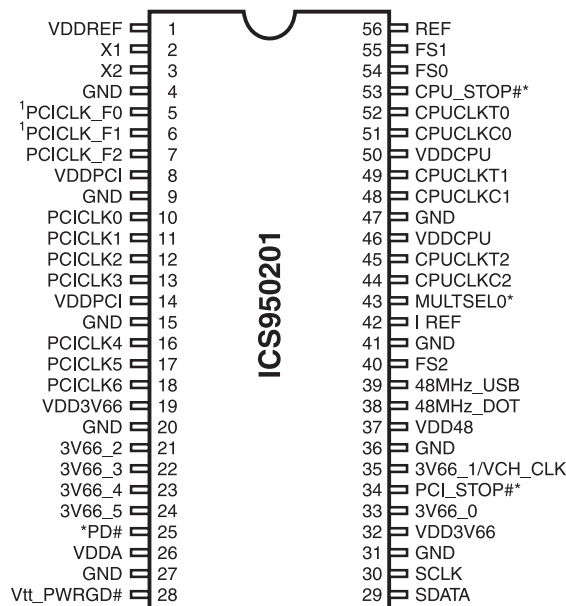
Pin Configuration

56-Pin SSOP & TSSOP

* These inputs have 150K internal pull-up resistor to VDD.

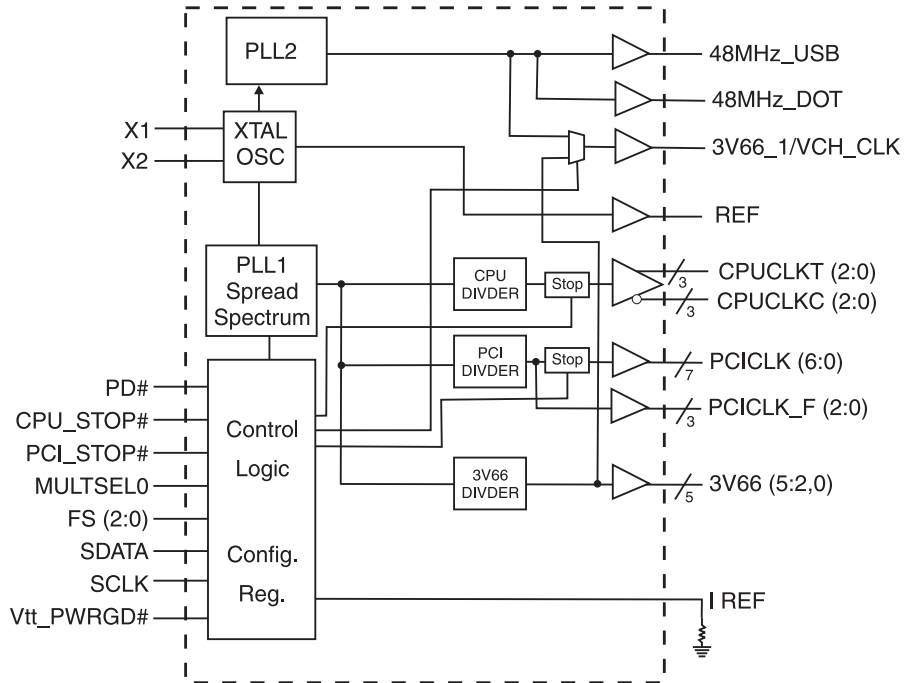
Block Diagram



Pin Description

| PIN NUMBER | PIN NAME | TYPE | DESCRIPTION |
|----------------------------------|----------------|-------------------|---|
| 1, 8, 14, 19, 26, 32, 37, 46, 50 | VDD | PWR | 3.3V power supply |
| 2 | X1 | X2 Crystal Input | 14.318MHz Crystal input |
| 3 | X2 | X1 Crystal Output | 14.318MHz Crystal output |
| 7, 6, 5 | PCICLK_F (2:0) | OUT | Free running PCI clock not affected by PCI_STOP# for power management. |
| 4, 9, 15, 20, 27, 31, 36, 41, 47 | GND | PWR | Ground pins for 3.3V supply |
| 18, 17, 16, 13, 12, 11, 10 | PCICLK (6:0) | OUT | PCI clock outputs |
| 24, 23, 22, 21 | 3V66 (5:2) | OUT | 66MHz reference clocks, from internal VCO |
| 24 | 3V66_5 | OUT | 66MHz reference clock, from internal VCO |
| 25 | PD# | IN | Invokes power-down mode. Active Low. |
| 28 | Vtt_PWRGD# | IN | This 3.3V LVTTTL input is a level sensitive strobe used to determine when FS(2:0) and MULTISEL0 inputs are valid and are ready to be sampled (active low) |
| 29 | SDATA | I/O | Data pin for I ² C circuitry 5V tolerant |
| 30 | SCLK | IN | Clock pin of I ² C circuitry 5V tolerant |
| 33 | 3V66_0 | OUT | 66MHz reference clocks, from internal VCO |
| 34 | PCI_STOP# | IN | Halts PCICLK clocks at logic 0 level, when input low except PCICLK_F which are free running |
| 35 | 3V66_1/VCH_CLK | OUT | 3.3V output selectable through I ² C to be 66MHz from internal VCO or 48MHz (non-SSC) |
| 38 | 48MHz_DOT | OUT | 48MHz output clock for DOT |
| 39 | 48MHz_USB | OUT | 48MHz output clock for USB |
| 40 | FS2 | IN | Special 3.3V input for Mode selection, cannot be logic 1 |
| , 42 | I REF | OUT | This pin establishes the reference current for the CPUCLK pairs. This pin requires a fixed precision resistor tied to ground in order to establish the appropriate current. |
| 43 | MULTSEL0 | IN | 3.3V LVTTTL input for selecting the current multiplier for CPU outputs |
| 44, 48, 51 | CPUCLKC (2:0) | OUT | "Complementary" clocks of differential pair CPU outputs. These are current outputs and external resistors are required for voltage bias. |
| 45, 49, 52 | CPUCLKT (2:0) | OUT | "True" clocks of differential pair CPU outputs. These are current outputs and external resistors are required for voltage bias. |
| 53 | CPU_STOP# | IN | Halts CPUCLK clocks at logic 0 level, when input low |
| 55, 54 | FS (1:0) | IN | Frequency select pins |
| 56 | REF | OUT | 14.318MHz reference clock. |

Power Groups

(Analog)

VDDA = Analog Core PLL1
 VDDREF = REF, Xtal
 VDD48 = 48MHz, PLL

(Digital)

VDDPCI
 VDD3V66
 VDDCPU

Truth Table

| FS2 | FS1 | FS0 | CPU (MHz) | 3V66 (5:0) (MHz) | PCI_F PCI (MHz) | REF0 (MHz) | USB/DOT (MHz) |
|-----|-----|-----|-----------|------------------|-----------------|------------|---------------|
| 0 | 0 | 0 | 66.66 | 66.66 | 33.33 | 14.318 | 48.00 |
| 0 | 0 | 1 | 100.00 | 66.66 | 33.33 | 14.318 | 48.00 |
| 0 | 1 | 0 | 200.00 | 66.66 | 33.33 | 14.318 | 48.00 |
| 0 | 1 | 1 | 133.33 | 66.66 | 33.33 | 14.318 | 48.00 |
| Mid | 0 | 0 | Tristate | Tristate | Tristate | Tristate | Tristate |
| Mid | 0 | 1 | TCLK/2 | TCLK/4 | TCLK/8 | TCLK | TCLK/2 |
| Mid | 1 | 0 | Reserved | Reserved | Reserved | Reserved | Reserved |
| Mid | 1 | 1 | Reserved | Reserved | Reserved | Reserved | Reserved |

Maximum Allowed Current

| Condition | Max 3.3V supply consumption Max discrete cap loads, V _{dd} = 3.465V All static inputs = V _{dd} or GND |
|-------------|--|
| Full Active | 360mA |

Host Swing Select Functions

| MULTISELO | Board Target Trace/Term Z | Reference R, I _{ref} = $V_{DD}/(3 \cdot R_r)$ | Output Current | V _{oh} @ Z |
|-----------|---------------------------|--|--|---------------------|
| 1 | 50 ohms | R _r = 475 1%, I _{ref} = 2.32mA | I _{oh} = 6 * I _{REF} | 0.7V @ 50 |

General I²C serial interface information

The information in this section assumes familiarity with I²C programming.
 For more information, contact IDT for an I²C programming application note.

How to Write:

- Controller (host) sends a start bit.
- Controller (host) sends the write address D2_(H)
- ICS clock will **acknowledge**
- Controller (host) sends a dummy command code
- ICS clock will **acknowledge**
- Controller (host) sends a dummy byte count
- ICS clock will **acknowledge**
- Controller (host) starts sending first byte (Byte 0) through byte 5
- ICS clock will **acknowledge** each byte **one at a time**.
- Controller (host) sends a Stop bit

How to Read:

- Controller (host) will send start bit.
- Controller (host) sends the read address D3_(H)
- ICS clock will **acknowledge**
- ICS clock will send the **byte count**
- Controller (host) acknowledges
- ICS clock sends first byte (**Byte 0**) through **byte 6**
- Controller (host) will need to acknowledge each byte
- Controller (host) will send a stop bit

| How to Write: | |
|------------------------------|----------------------|
| Controller (Host) | ICS (Slave/Receiver) |
| Start Bit | |
| Address D2 _(H) | |
| | ACK |
| Dummy Command Code | |
| | ACK |
| Dummy Byte Count | |
| | ACK |
| Byte 0 | |
| | ACK |
| Byte 1 | |
| | ACK |
| Byte 2 | |
| | ACK |
| Byte 3 | |
| | ACK |
| Byte 4 | |
| | ACK |
| Byte 5 | |
| | ACK |
| Byte 6 | |
| | ACK |
| Stop Bit | |

| How to Read: | |
|------------------------------|----------------------|
| Controller (Host) | ICS (Slave/Receiver) |
| Start Bit | |
| Address D3 _(H) | |
| | ACK |
| | Byte Count |
| ACK | |
| | Byte 0 |
| ACK | |
| | Byte 1 |
| ACK | |
| | Byte 2 |
| ACK | |
| | Byte 3 |
| ACK | |
| | Byte 4 |
| ACK | |
| | Byte 5 |
| ACK | |
| | Byte 6 |
| ACK | |
| Stop Bit | |

Notes:

1. The ICS clock generator is a slave/receiver, I²C component. It can read back the data stored in the latches for verification. **Read-Back will support Intel PIIX4 "Block-Read" protocol.**
2. The data transfer rate supported by this clock generator is 100K bits/sec or less (standard mode)
3. The input is operating at 3.3V logic levels.
4. The data byte format is 8 bit bytes.
5. To simplify the clock generator I²C interface, the protocol is set to use only "**Block-Writes**" from the controller. The bytes must be accessed in sequential order from lowest to highest byte with the ability to stop after any complete byte has been transferred. The Command code and Byte count shown above must be sent, but the data is ignored for those two bytes. The data is loaded until a Stop sequence is issued.
6. At power-on, all registers are set to a default condition, as shown.

Byte 0: Control Register

| Bit | Pin# | Name | PWD ² | Type ¹ | Description |
|-------|------|------------------------|------------------|-------------------|---|
| Bit 0 | 54 | FS0 | X | R | Reflects the value of FS0 pin sampled on power up |
| Bit 1 | 55 | FS1 | X | R | Reflects the value of FS1 pin sampled on power up |
| Bit 2 | 40 | FS2 | X | R | Reflects the value of FS2 pin sampled on power up |
| Bit 3 | 34 | PCI_STOP# ³ | X | R | Hardware mode: Reflects the value of PCI_STOP# pin sampled on PWD |
| | | | 1 | RW | Software mode: 0=PCICLK stopped 1=PCICLK not stopped |
| Bit 4 | 53 | CPU_STOP# | X | R | Reflects the current value of the external CPU_STOP# pin |
| Bit 5 | 35 | 3V66_1/VCH | 0 | RW | VCH Select 66MHz/48MHz 0=66MHz, 1=48MHz |
| Bit 6 | - | | 0 | | (Reserved) |
| Bit 7 | - | Spread Enabled | 0 | RW | 0=Spread Off, 1=Spread On |

Byte 1: Control Register

| Bit | Pin# | Name | PWD ² | Type ¹ | Description |
|-------|--------|----------------------|------------------|-------------------|--|
| Bit 0 | 52, 51 | CPUCLKT0 CPUCLKC0 | 1 | RW | 0=Disabled 1=Enabled ⁴ |
| Bit 1 | 49, 48 | CPUCLKT1 CPUCLKC1 | 1 | RW | 0=Disabled 1=Enabled ⁴ |
| Bit 2 | 45, 44 | CPUCLKT2 CPUCLKC2 | 1 | RW | 0=Disabled 1=Enabled ⁴ |
| Bit 3 | 52, 51 | CPUCLKT0 CPUCLKC0 | 0 | RW | Allow control of CPUCLKT0/C0 with assertion of CPU_STOP# 0=Not free running 1=Free running |
| Bit 4 | 49, 48 | CPUCLKT1 CPUCLKC1 | 0 | RW | Allow control of CPUCLKT1/C1 with assertion of CPU_STOP# 0=Not free running 1=Free running |
| Bit 5 | 45, 44 | CPUCLKT2 CPUCLKC2 | 0 | RW | Allow control of CPUCLKT2/C2 with assertion of CPU_STOP# 0=Not free running 1=Free running |
| Bit 6 | - | - | 0 | - | (Reserved) |
| Bit 7 | 43 | MULTSELO | X | R | Reflects the current value of MULTSELO |

Notes:

1. R= Read only RW= Read and Write
2. PWD = Power on Default
3. The purpose of this bit is to allow a system designer to implement PCI_STOP functionality in one of two ways. With the system designer can choose to use the externally provided PCI_STOP# pin to assert and de-assert PCI_STOP functionality via I²C Byte 0 Bit 3.

In Hardware mode it is not allowed to write to the I²C Byte 0 Bit3. In Software mode it is not allowed to pull the external PCI_STOP pin low. This avoids the issues related with Hardware started and software stopped PCI_STOP conditions. The clock chip is to be operated in the Hardware or Software PCI_STOP mode ONLY, it is not allowed to mix these modes.

In Hardware mode the I²C byte 0 Bit 3 is R/W and should reflect the status of the part. Whether or not the chip is in PCI_STOP mode.

Functionality PCI_STOP mode should be entered when [(PCI_STOP#=0) or (I²C Byte 0 Bit 3 = 0)].

4. For disabled clocks, they stop low for single ended clocks. Differential CPU clocks stop with CPUCLKT at high, CPUCLKC off, and external resistor termination will bring CPUCLKC low.

Byte 2: Control Register

| Bit | Pin# | Name | PWD | Type | Description |
|-------|------|---------|-----|------|----------------------|
| Bit 0 | 10 | PCICLK0 | 1 | RW | 0=Disabled 1=Enabled |
| Bit 1 | 11 | PCICLK1 | 1 | RW | 0=Disabled 1=Enabled |
| Bit 2 | 12 | PCICLK2 | 1 | RW | 0=Disabled 1=Enabled |
| Bit 3 | 13 | PCICLK3 | 1 | RW | 0=Disabled 1=Enabled |
| Bit 4 | 16 | PCICLK4 | 1 | RW | 0=Disabled 1=Enabled |
| Bit 5 | 17 | PCICLK5 | 1 | RW | 0=Disabled 1=Enabled |
| Bit 6 | 18 | PCICLK6 | 1 | RW | 0=Disabled 1=Enabled |
| Bit 7 | - | - | 0 | - | (Reserved) |

Byte 3: Control Register

| Bit | Pin# | Name | PWD | Type | Description |
|-------|------|-----------|-----|------|--|
| Bit 0 | 5 | PCICLK_F0 | 1 | RW | 0=Disabled 1=Enabled |
| Bit 1 | 6 | PCICLK_F1 | 1 | RW | 0=Disabled 1=Enabled |
| Bit 2 | 7 | PCICLK_F2 | 1 | RW | 0=Disabled 1=Enabled |
| Bit 3 | 5 | PCICLK_F0 | 0 | RW | Allow control of PCICLK_F0 with assertion of PCI_STOP#. 0=Free Running, 1=Not free running |
| Bit 4 | 6 | PCICLK_F1 | 0 | RW | Allow control of PCICLK_F1 with assertion of PCI_STOP#. 0=Free Running, 1=Not free running |
| Bit 5 | 7 | PCICLK_F2 | 0 | RW | Allow control of PCICLK_F2 with assertion of PCI_STOP#. 0=Free Running, 1=Not free running |
| Bit 6 | 39 | 48MHz_USB | 1 | RW | 0=Disabled 1=Enabled |
| Bit 7 | 38 | 48MHz_DOT | 1 | RW | 0=Disabled 1=Enabled |

Byte 4: Control Register

| Bit | Pin# | Name | PWD | Type | Description |
|-------|------|----------------|-----|------|----------------------|
| Bit 0 | 21 | 3V66-2 | 1 | RW | 0=Disabled 1=Enabled |
| Bit 1 | 22 | 3V66-3 | 1 | RW | 0=Disabled 1=Enabled |
| Bit 2 | 23 | 3V66-4 | 1 | RW | 0=Disabled 1=Enabled |
| Bit 3 | 24 | 3V66_5 | 1 | RW | 0=Disabled 1=Enabled |
| Bit 4 | 35 | 3V66_1/VCH_CLK | 1 | RW | 0=Disabled 1=Enabled |
| Bit 5 | 33 | 3V66_0 | 1 | RW | 0=Disabled 1=Enabled |
| Bit 6 | - | - | 0 | R | (Reserved) |
| Bit 7 | - | - | 0 | R | (Reserved) |

Notes:

1. R= Read only RW= Read and Write
2. PWD = Power on Default

Absolute Maximum Ratings

| | |
|-------------------------------|--------------------------------|
| Supply Voltage | 5.5 V |
| Logic Inputs | GND -0.5 V to $V_{DD} + 0.5 V$ |
| Ambient Operating Temperature | 0°C to +70°C |
| Case Temperature | 115°C |
| Storage Temperature | -65°C to +150°C |

Stresses above those listed under *Absolute Maximum Ratings* may cause permanent damage to the device. These ratings are stress specifications only and functional operation of the device at these or any other conditions above those listed in the operational sections of the specifications is not implied. Exposure to absolute maximum rating conditions for extended periods may affect product reliability.

Electrical Characteristics - Input/Supply/Common Output Parameters

$T_A = 0 - 70^\circ\text{C}$; Supply Voltage $V_{DD} = 3.3 V \pm 5\%$

| PARAMETER | SYMBOL | CONDITIONS | MIN | TYP | MAX | UNITS |
|--------------------------------|--------------------|---|----------------|--------|----------------|---------------|
| Input High Voltage | V_{IH} | | 2 | | $V_{DD} + 0.3$ | V |
| Input Low Voltage | V_{IL} | | $V_{SS} - 0.3$ | | 0.8 | V |
| Input High Current | I_{IH} | $V_{IN} = V_{DD}$ | -5 | | 5 | μA |
| Input Low Current | I_{IL1} | $V_{IN} = 0 V$; Inputs with no pull-up resistors | -5 | | | μA |
| | I_{IL2} | $V_{IN} = 0 V$; Inputs with pull-up resistors | -200 | | | |
| Operating Supply Current | $I_{DD3.3OP}$ | $C_L = \text{Full load}$; Select @ 100 MHz | 229 | 240 | 360 | mA |
| | $I_{DD3.3OP}$ | $C_L = \text{Full load}$; Select @ 133 MHz | 220 | 236 | 360 | mA |
| | $I_{DD3.3OP}$ | $C_L = \text{Full load}$; Select @ 200 MHz | 234 | 245 | 360 | mA |
| Powerdown Current | $I_{DD3.3PD}$ | | | | 45 | mA |
| Input Frequency | F_i | $V_{DD} = 3.3 V$ | | 14.318 | | MHz |
| Pin Inductance | L_{pin} | | | | 7 | nH |
| Input Capacitance ¹ | C_{IN} | Logic Inputs | | | 5 | pF |
| | C_{OUT} | Output pin capacitance | | | 6 | pF |
| | C_{INX} | X1 & X2 pins | 27 | | 45 | pF |
| Transition time ¹ | T_{trans} | To 1st crossing of target frequency | | | 3 | ms |
| Settling time ¹ | T_s | From 1st crossing to 1% target frequency | | | 3 | ms |
| Clk Stabilization ¹ | T_{STAB} | From $V_{DD} = 3.3 V$ to 1% target frequency | | | 3 | ms |
| Delay ¹ | t_{PZH}, t_{PZL} | Output enable delay (all outputs) | 1 | | 10 | ns |
| | t_{PHZ}, t_{PLZ} | Output disable delay (all outputs) | 1 | | 10 | ns |

¹Guaranteed by design, not 100% tested in production.

Electrical Characteristics - CPU 0.7V Current Mode Differential Pair

T_A = 0 - 70°C; V_{DD} = 3.3 V +/-5%; C_L =2pF

| PARAMETER | SYMBOL | CONDITIONS | MIN | TYP | MAX | UNITS | NOTES |
|---------------------------------|----------------------------------|--|--------|-----|---------|-------|-------|
| Current Source Output Impedance | Z _o ¹ | V _O = V _x | 3000 | | | Ω | 1 |
| Voltage High | V _{High} | Statistical measurement on single ended signal using oscilloscope math function. | 660 | 770 | 850 | mV | 1 |
| Voltage Low | V _{Low} | | -150 | 5 | 150 | | 1 |
| Max Voltage | V _{ovs} | Measurement on single ended signal using absolute value. | | 756 | 1150 | mV | 1 |
| Min Voltage | V _{uds} | | -300 | -7 | | | 1 |
| Crossing Voltage (abs) | V _{cross(abs)} | | 250 | 350 | 550 | mV | 1 |
| Crossing Voltage (var) | d-V _{cross} | Variation of crossing over all edges | | 12 | 140 | mV | 1 |
| Long Accuracy | ppm | see T _{period} min-max values | -300 | | 300 | ppm | 1,2 |
| Average period | T _{period} | 200MHz nominal | 4.9985 | | 5.0015 | ns | 2 |
| | | 200MHz spread | 4.9985 | | 5.0266 | ns | 2 |
| | | 166.66MHz nominal | 5.9982 | | 6.0018 | ns | 2 |
| | | 166.66MHz spread | 5.9982 | | 6.0320 | ns | 2 |
| | | 133.33MHz nominal | 7.4978 | | 7.5023 | ns | 2 |
| | | 133.33MHz spread | 7.4978 | | 5.4000 | ns | 2 |
| | | 100.00MHz nominal | 9.9970 | | 10.0030 | ns | 2 |
| | | 100.00MHz spread | 9.9970 | | 10.0533 | ns | 2 |
| Absolute min period | T _{absmin} | 200MHz nominal | 4.8735 | | | ns | 1,2 |
| | | 166.66MHz nominal/spread | 5.8732 | | | ns | 1,2 |
| | | 133.33MHz nominal/spread | 7.3728 | | | ns | 1,2 |
| | | 100.00MHz nominal/spread | 9.8720 | | | ns | 1,2 |
| Rise Time | t _r | V _{OL} = 0.175V, V _{OH} = 0.525V | 175 | 332 | 700 | ps | 1 |
| Fall Time | t _f | V _{OH} = 0.525V V _{OL} = 0.175V | 175 | 344 | 700 | ps | 1 |
| Rise Time Variation | d-t _r | | | 30 | 125 | ps | 1 |
| Fall Time Variation | d-t _f | | | 30 | 125 | ps | 1 |
| Duty Cycle | d _{t3} | Measurement from differential waveform | 45 | 49 | 55 | % | 1 |
| Skew | t _{sk3} | V _T = 50% | | 8 | 100 | ps | 1 |
| Jitter, Cycle to cycle | t _{j_{cyc-cyc}} | Measurement from differential waveform | | 60 | 150 | ps | 1 |

¹Guaranteed by design, not 100% tested in production.

² All Long Term Accuracy and Clock Period specifications are guaranteed with the assumption that Ref output is at 14.31818MHz

Electrical Characteristics - PCICLK

$T_A = 0 - 70^\circ\text{C}$; $V_{DD} = 3.3\text{V} \pm 5\%$; $C_L = 10\text{-}30\text{ pF}$ (unless otherwise specified)

| PARAMETER | SYMBOL | CONDITIONS | MIN | TYP | MAX | UNITS |
|----------------------|-----------------|--|-----|-------|------|----------|
| Output Frequency | F_{O1} | | | 33.33 | | MHz |
| Output Impedance | R_{DSP1}^1 | $V_O = V_{DD} * (0.5)$ | 12 | 33 | 55 | Ω |
| Output High Voltage | V_{OH}^1 | $I_{OH} = -1\text{ mA}$ | 2.4 | | | V |
| Output Low Voltage | V_{OL}^1 | $I_{OL} = 1\text{ mA}$ | | | 0.55 | V |
| Output High Current | I_{OH}^1 | $V_{OH@MIN} = 1.0\text{ V}, V_{OH@MAX} = 3.135\text{ V}$ | -33 | | -33 | mA |
| Output Low Current | I_{OL}^1 | $V_{OL@MIN} = 1.95\text{ V}, V_{OL@MAX} = 0.4\text{ V}$ | 30 | | 38 | mA |
| Rise Time | t_{r1}^1 | $V_{OL} = 0.4\text{ V}, V_{OH} = 2.4\text{ V}$ | 0.5 | 1.29 | 2 | ns |
| Fall Time | t_{f1}^1 | $V_{OH} = 2.4\text{ V}, V_{OL} = 0.4\text{ V}$ | 0.5 | 1.45 | 2 | ns |
| Duty Cycle | d_{t1}^1 | $V_T = 1.5\text{ V}$ | 45 | 51 | 55 | % |
| Skew | t_{sk1}^1 | $V_T = 1.5\text{ V}$ | | 190 | 500 | ps |
| Jitter, cycle to cyc | $t_{jyc-cyc}^1$ | $V_T = 1.5\text{ V}$ | | 124 | 250 | ps |

¹Guaranteed by design, not 100% tested in production.

Electrical Characteristics - 3V66

$T_A = 0 - 70^\circ\text{C}$; $V_{DD} = 3.3\text{V} \pm 5\%$; $C_L = 10\text{-}30\text{ pF}$ (unless otherwise specified)

| PARAMETER | SYMBOL | CONDITIONS | MIN | TYP | MAX | UNITS |
|---------------------|-----------------|--|-----|-------|------|----------|
| Output Frequency | F_{O1} | | | 66.67 | | MHz |
| Output Impedance | R_{DSP1}^1 | $V_O = V_{DD} * (0.5)$ | 12 | 33 | 55 | Ω |
| Output High Voltage | V_{OH}^1 | $I_{OH} = -1\text{ mA}$ | 2.4 | | | V |
| Output Low Voltage | V_{OL}^1 | $I_{OL} = 1\text{ mA}$ | | | 0.55 | V |
| Output High Current | I_{OH}^1 | $V_{OH@MIN} = 1.0\text{ V}, V_{OH@MAX} = 3.135\text{ V}$ | -33 | | -33 | mA |
| Output Low Current | I_{OL}^1 | $V_{OL@MIN} = 1.95\text{ V}, V_{OL@MAX} = 0.4\text{ V}$ | 30 | | 38 | mA |
| Rise Time | t_{r1}^1 | $V_{OL} = 0.4\text{ V}, V_{OH} = 2.4\text{ V}$ | 0.5 | 1.28 | 2 | ns |
| Fall Time | t_{f1}^1 | $V_{OH} = 2.4\text{ V}, V_{OL} = 0.4\text{ V}$ | 0.5 | 1.36 | 2 | ns |
| Duty Cycle | d_{t1}^1 | $V_T = 1.5\text{ V}$ | 45 | 53.1 | 55 | % |
| Skew | t_{sk1}^1 | $V_T = 1.5\text{ V}$ | | 90 | 250 | ps |
| Jitter | $t_{jyc-cyc}^1$ | $V_T = 1.5\text{ V}$ 3V66 | | 128 | 250 | ps |

¹Guaranteed by design, not 100% tested in production.

Un-Buffered Mode 3V66 & PCI Phase Relationship

All 3V66 clocks are to be in pphase with each other. In the case where 3V66_1 is configured as 48MHz VCH clock, there is no defined phase relationship between 3V66_1/VCH and other 3V66 clocks. The PCI group should lag 3V66 by the standard skew described below as Tpci.

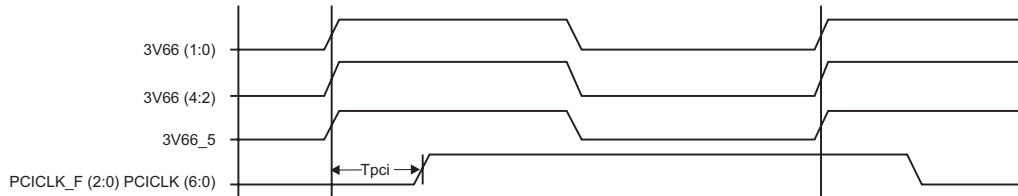

Group Skews at Common Transition Edges: (Un-Buffered Mode)

| GROUP | SYMBOL | CONDITIONS | MIN | TYP | MAX | UNITS |
|-------------|-----------------------|-------------------------------|-----|-----|-----|-------|
| 3V66 | 3V66 | 3V66 pin to pin skew | 0 | | 500 | ps |
| PCI | PCI | PCI_F and PCI pin to pin skew | 0 | | 500 | ps |
| 3V66 to PCI | S _{3V66-PCI} | 3V66 leads 33MHz PCI | 1.5 | | 3.5 | ns |

¹Guaranteed by design, not 100% tested in production.

PD# Functionality

| CPU_STOP# | CPUT | CPUC | 3V66 | 66MHz_OUT | PCICLK_F PCICLK | PCICLK | USB/DOT 48MHz |
|-----------|-------------|--------|-------|-----------|--------------------|----------|------------------|
| 1 | Normal | Normal | 66MHz | 66MHz_IN | 66MHz_IN | 66MHz_IN | 48MHz |
| 0 | iref * Mult | Float | Low | Low | Low | Low | Low |

PCI_STOP# - Assertion (transition from logic "1" to logic "0")

The impact of asserting the PCI_STOP# signal will be the following. All PCI[6:0] and stoppable PCI_F[2,0] clocks will latch low in their next high to low transition. The PCI_STOP# setup time tsu is 10 ns, for transitions to be recognized by the next rising edge.

Assertion of PCI_STOP# Waveforms

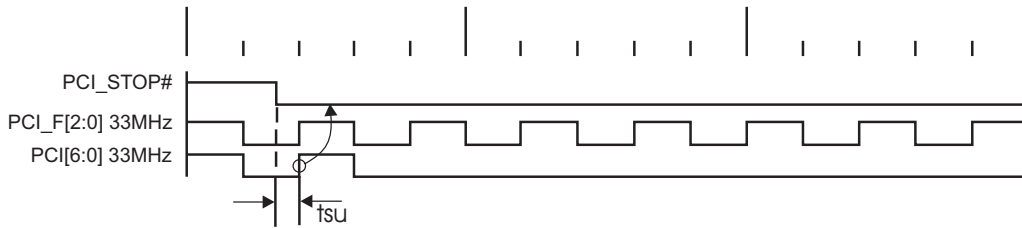

CPU_STOP# - Assertion (transition from logic "1" to logic "0")

The impact of asserting the CPU_STOP# pin is all CPU outputs that are set in the I²C configuration to be stoppable via assertion of CPU_STOP# are to be stopped after their next transition following the two CPU clock edge sampling as shown. The final state of the stopped CPU signals is CPUT=High and CPUC=Low. There is to be no change to the output drive current values. The CPUT will be driven high with a current value equal to (MULTSEL0) X (I REF), the CPUC signal will not be driven.

Assertion of CPU_STOP# Waveforms

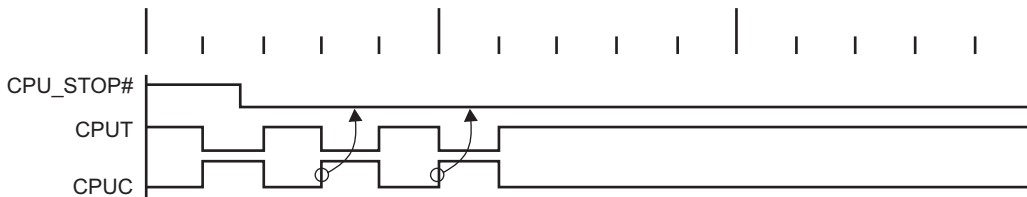

CPU_STOP# Functionality

| CPU_STOP# | CPUT | CPUC |
|-----------|-------------|--------|
| 1 | Normal | Normal |
| 0 | iref * Mult | Float |

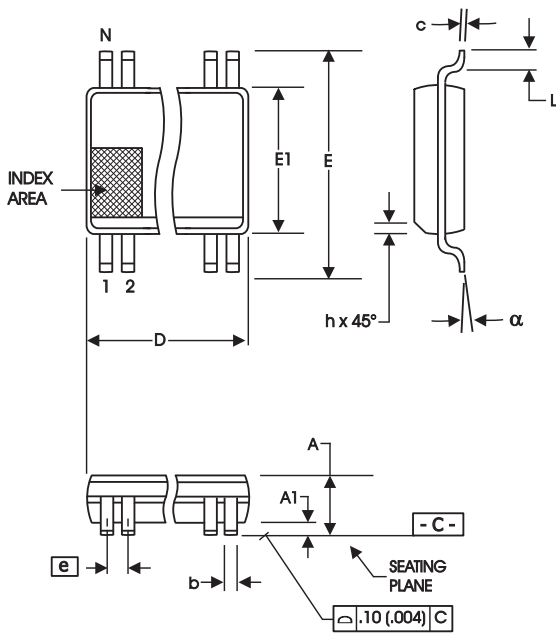

300 mil SSOP Package

| SYMBOL | In Millimeters COMMON DIMENSIONS | | In Inches COMMON DIMENSIONS | |
|----------|-------------------------------------|-------|--------------------------------|-------|
| | MIN | MAX | MIN | MAX |
| A | 2.41 | 2.80 | .095 | .110 |
| A1 | 0.20 | 0.40 | .008 | .016 |
| b | 0.20 | 0.34 | .008 | .0135 |
| c | 0.13 | 0.25 | .005 | .010 |
| D | SEE VARIATIONS | | SEE VARIATIONS | |
| E | 10.03 | 10.68 | .395 | .420 |
| E1 | 7.40 | 7.60 | .291 | .299 |
| e | 0.635 BASIC | | 0.025 BASIC | |
| h | 0.38 | 0.64 | .015 | .025 |
| L | 0.50 | 1.02 | .020 | .040 |
| N | SEE VARIATIONS | | SEE VARIATIONS | |
| α | 0° | 8° | 0° | 8° |

| VARIATIONS | | | | |
|------------|-------|-------|----------|------|
| N | D mm. | | D (inch) | |
| | MIN | MAX | MIN | MAX |
| 56 | 18.31 | 18.55 | .720 | .730 |

Reference Doc.: JEDEC Publication 95, MO-118

10-0034

Ordering Information

950201yFLF-T

Example:

XXXX y F LF-T

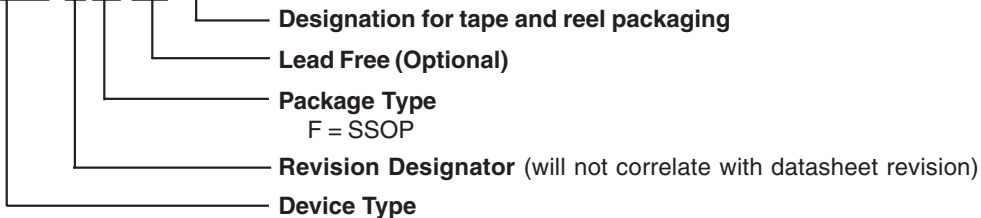

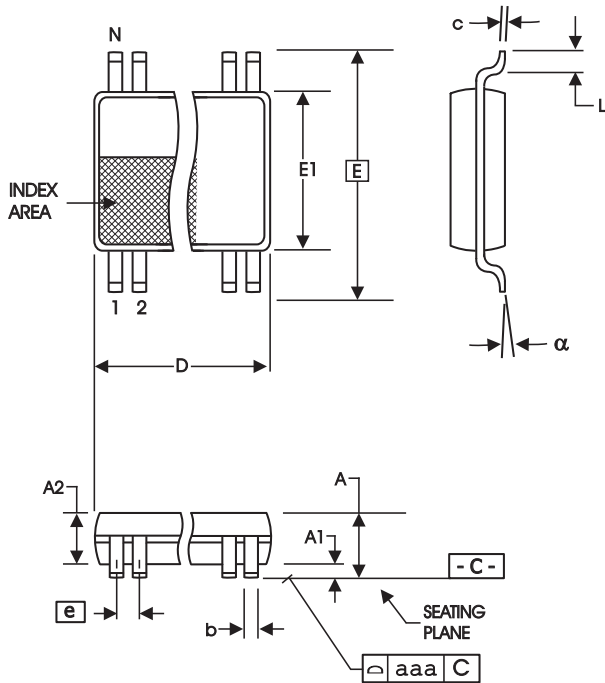

6.10 mm. Body, 0.50 mm. pitch TSSOP
 (240 mil) (0.020 mil)

| SYMBOL | In Millimeters | | In Inches | |
|--------|-------------------|-------------------|-------------------|-------------------|
| | COMMON DIMENSIONS | COMMON DIMENSIONS | COMMON DIMENSIONS | COMMON DIMENSIONS |
| A | -- | 1.20 | -- | .047 |
| A1 | 0.05 | 0.15 | .002 | .006 |
| A2 | 0.80 | 1.05 | .032 | .041 |
| b | 0.17 | 0.27 | .007 | .011 |
| c | 0.09 | 0.20 | .0035 | .008 |
| D | SEE VARIATIONS | | SEE VARIATIONS | |
| E | 8.10 BASIC | | 0.319 BASIC | |
| E1 | 6.00 | 6.20 | .236 | .244 |
| e | 0.50 BASIC | | 0.020 BASIC | |
| L | 0.45 | 0.75 | .018 | .030 |
| N | SEE VARIATIONS | | SEE VARIATIONS | |
| alpha | 0° | 8° | 0° | 8° |
| aaa | -- | 0.10 | -- | .004 |

VARIATIONS

| N | D mm. | | D (inch) | |
|----|-------|-------|----------|------|
| | MIN | MAX | MIN | MAX |
| 56 | 13.90 | 14.10 | .547 | .555 |

Reference Doc.: JEDEC Publication 95, MO-153
 10-0039

Ordering Information

950201yGLF-T

Example:

XXXX y G LF-T

- XXXX — Designation for tape and reel packaging
- y — Lead Free (Optional)
- G — Package Type
G = TSSOP
- LF — Revision Designator (will not correlate with datasheet revision)
- T — Device Type

Revision History

| Rev. | Issue Date | Description | Page # |
|------|------------|---------------------------|--------|
| J | 1/25/2010 | Updated document template | |
| | | | |
| | | | |
| | | | |

Innovate with IDT and accelerate your future networks. Contact:

www.IDT.com

For Sales

800-345-7015
408-284-8200
Fax: 408-284-2775

For Tech Support

408-284-6578
pcclockhelp@idt.com

Corporate Headquarters

Integrated Device Technology, Inc.
6024 Silver Creek Valley Road
San Jose, CA 95138
United States
800 345 7015
+408 284 8200 (outside U.S.)

Asia Pacific and Japan

Integrated Device Technology
Singapore (1997) Pte. Ltd.
Reg. No. 199707558G
435 Orchard Road
#20-03 Wisma Atria
Singapore 238877
+65 6 887 5505

Europe

IDT Europe, Limited
Prime House
Barnett Wood Lane
Leatherhead, Surrey
United Kingdom KT22 7DE
+44 1372 363 339



www.IDT.com

Looking for pricing, stock, or lifecycle information?

Click below to explore more details on WIN SOURCE:

- ⊖ [View 950201AFLF on WIN SOURCE](#)
- ⊖ [IDT, Integrated Device Technology Inc Information](#)

Optimize Your Supply Chain with WIN SOURCE Solutions

- ✓ Global Sourcing Solution
- ✓ Obsolete Management
- ✓ Cost Control Management
- ✓ Shortage Management
- ✓ Alternative Solution
- ✓ Excess Inventory Management