



**THE DATASHEET OF
TSM101ACDTR**





TSM101/A

VOLTAGE AND CURRENT CONTROLLER

- 1.24V SERIES VOLTAGE REFERENCE WITH 10mA OUTPUT CURRENT AND 1% PRECISION (TSM101A)
- TWO OPERATIONAL AMPLIFIERS WITH ORED OUTPUT AND 1MHZ GAIN BANDWIDTH PRODUCT
- BUILT-IN CURRENT GENERATOR WITH ENABLE/DISABLE FUNCTION
- 4.5 TO 32V SUPPLY VOLTAGE RANGE
- SO8 AND DIP8 PACKAGES

DESCRIPTION

The TSM101/TSM101A integrated circuit incorporates a high stability series band gap voltage reference, two ORed operational amplifiers and a current source.

This IC compares the DC voltage and the current level at the output of a switching power supply to an internal reference. It provides a feedback through an optocoupler to the PWM controller IC in the primary side.

The controlled current generator can be used to modify the level of current limitation by offsetting the information coming from the current sensing resistor.

APPLICATIONS

This circuit is designed to be used in battery chargers with a constant voltage and a limited output current.

It can be used in every types of application requiring a precision voltage regulation and current limitation.

Other applications include voltage supervisors, over voltage protection...

ORDER CODE

Part Number	Temperature Range	Package	
		N	D
TSM101C/AC	-20°C, +80°C	•	•
TSM101I/AI	-40°C, +105°C	•	•

N = Dual in Line Package (DIP)
D = Small Outline Package (SO) - also available in Tape & Reel (DT)

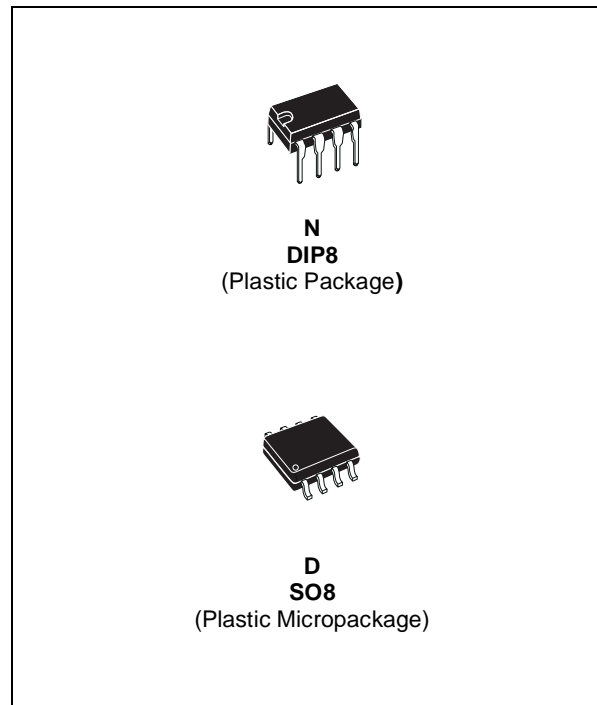

PIN CONNECTIONS (top view)

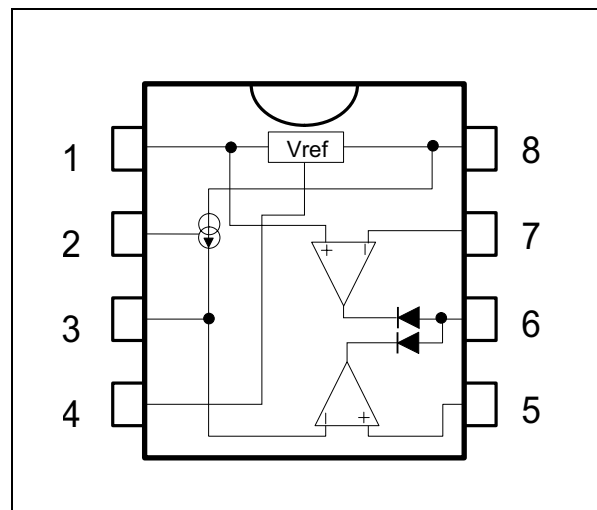

ABSOLUTE MAXIMUM RATINGS

Symbol	Parameter	Value	Unit
V_{CC}	DC supply Voltage ¹⁾	36	V
I_{out}	Output Current ²⁾	20	mA
P_d	Power Dissipation	200	mW
V_{in}	Input Voltage ³⁾	-0.3, $V_{CC} - 1.5$	V
I_{in}	Input Current	± 1	mA
T_{stg}	Storage Temperature	-40 to +125	°C
T_j	Maximum Junction Temperature	150	°C
T_{thja}	Thermal Resistance Junction to Ambient	130 to 200	°C/W

1. All voltages values, except differential voltage are with respect to network ground terminal.
2. The voltage reference is not protected against permanent short circuit.
3. The magnitude of input and output voltages must never exceed -0.3V or $V_{CC} - 1.5V$.

OPERATING CONDITIONS

Symbol	Parameter	Value	Unit
V_{CC}	Supply Voltage	4.5 to 32	V
T_{oper}	Operating Free Air Temperature Range	T_{max} to T_{min}	

ELECTRICAL CHARACTERISTICS

$T_{amb} = 25^\circ\text{C}$, $V_{CC} = 15\text{V}$ (unless otherwise specified)

OPERATIONAL AMPLIFIER: TSM101C/I/AC/AI

Symbol	Parameter	Min.	Typ.	Max.	Unit
I_{CC}	Total Supply Current $V_{CC} = 1.5\text{V}$			2	mA
V_i	Input Voltage Range	0		$V_{CC} - 1.5\text{V}$	V
V_{io}	Input Offset Voltage 25°C $T_{min.} \leq T_{amb} \leq T_{max.}$	-5 -7	1	5 7	mV
I_{ib}	Input Bias Current @ $V_{in} = 1.2\text{V}$ on pin and $V_{in} = 0\text{V}$ on pin 5 25°C $T_{min.} \leq T_{amb} \leq T_{max.}$	-700 -1000	-300	0 0	nA
I_{sink}	Output Sink Current, $V_{ol} = 2.5\text{V}$ 25°C $T_{min.} \leq T_{amb} \leq T_{max.}$	8	15		mA
A_{vo}	Large Signal Voltage Gain $R_L = 2\text{k}\Omega$ $T_{min.} \leq T_{amb} \leq T_{max.}$	15			V/mV
SVR	Supply Voltage Rejection Ratio $T_{min.} \leq T_{amb} \leq T_{max.}$	65	90		dB
CMR	Common Mode Rejection Ratio $T_{min.} \leq T_{amb} \leq T_{max.}$		80		dB
GBP	Gain Bandwidth Product $V_{CC} = 15\text{V}$, $F = 100\text{kHz}$ $V_{in} = 10\text{mV}$, $R_L = 2\text{k}\Omega$, $C_L = 100\text{pF}$		1		MHz
I_o	Output Leakage Current 25°C $T_{min.} \leq T_{amb} \leq T_{max.}$			2 7	μA

ELECTRICAL CHARACTERISTICS

$T_{amb} = 25^{\circ}\text{C}$, $V_{CC} = 15\text{V}$ (unless otherwise specified)

VOLTAGE REFERENCE : TSM101

Symbol	Parameter	TSM101C			TSM101I			Unit
		Min.	Typ.	Max.	Min.	Typ.	Max.	
V_{ref}	Reference Voltage $I_{out} = 1\text{mA}$, $T_{amb} = 25^{\circ}\text{C}$	1.21	1.24	1.27	1.21	1.24	1.27	V
K_{vt}	Temperature Stability $T_{min} \leq T_{amb} \leq T_{max}$		30	100		35	120	ppm/ $^{\circ}\text{C}$
R_{eglo}	Load Regulation $1 < I_{out} < 10\text{mA}$		5	15		5	15	mV
R_{egli}	Line Regulation $5 < V_{in} < 32\text{V}$		3.5	10		3.5	10	mV

VOLTAGE REFERENCE : TSM101A

Symbol	Parameter	TSM101AC			TSM101AI			Unit
		Min.	Typ.	Max.	Min.	Typ.	Max.	
V_{ref}	Reference Voltage $I_{out} = 1\text{mA}$, $T_{amb} = 25^{\circ}\text{C}$	1.227	1.24	1.252	1.227	1.24	1.252	V
K_{vt}	Temperature Stability $T_{min} \leq T_{amb} \leq T_{max}$		30	100		35	120	ppm/ $^{\circ}\text{C}$
R_{eglo}	Load Regulation $1 < I_{out} < 10\text{mA}$		5	15		5	15	mV
R_{egli}	Line Regulation $5 < V_{in} < 32\text{V}$		3.5	10		3.5	10	mV

CURRENT GENERATOR: TSM101, TSM101A

Symbol	Parameter	TSM101C/AC			TSM101I/AI			Unit
		Min.	Typ.	Max.	Min.	Typ.	Max.	
I_o	Current Source		1.4			1.4		mA
K_{cgt}	Temperature Stability $T_{min} \leq T_{amb} \leq T_{max}$		500			600		ppm/ $^{\circ}\text{C}$
C_{glir}	Line Regulation $4.5 < V_{CC} < 32\text{V}$		0.003	0.03		0.003	0.03	mA
V_{csen}	Voltage at the enable pin to have $I_o = 1.4\text{mA}$ $T_{min} \leq T_{amb} \leq T_{max}$			0.6			0.6	V
V_{csdis}	Voltage at the enable pin to have $I_o = 0\text{mA}$ $T_{min} \leq T_{amb} \leq T_{max}$	2			2			V
I_{csen}	Input Current on the C_{sen} pin $T_{min} \leq T_{amb} \leq T_{max}$			30			30	μA
I_{csleak}	Leakage Current $V_{CS} = 2\text{V}$ $T_{min} \leq T_{amb} \leq T_{max}$		0.5	2		0.5	2	μA

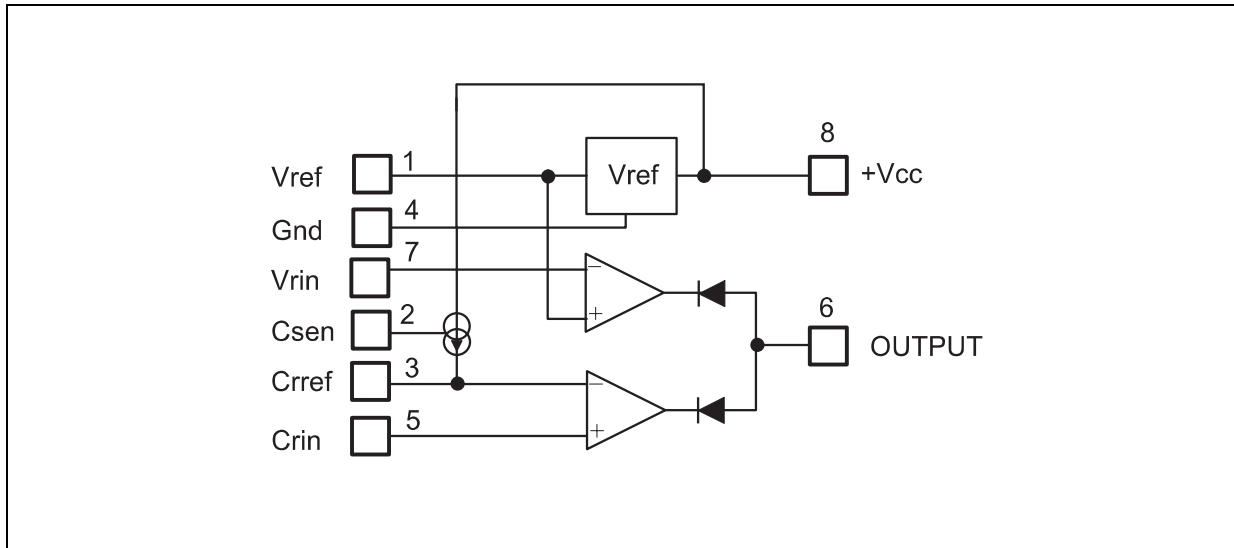

DESCRIPTION

Name	Pin	Type	Function
V_{ref}	1	OUTPUT	Voltage Reference Output 1.24V, 10mA max. Do not short circuit
V_{rin}	7	INPUT	Voltage Regulation Loop input
C_{rin}	5	INPUT	Current Limitation Loop Input, connected to the sense resistor
C_{rref}	3	INPUT	Current Limitation Reference Input
C_{sen}	2	INPUT	Current source enable input. This current source can be used to offset the voltage measurement on the sense resistor and therefore to modify the charge current. The current source is enabled when the input voltage on pin 2 is lower than 0.8V.
OUTPUT	6	OUTPUT	Output pin common to the voltage regulation and current limitation loops. This output can drive the primary side (LED) of an optocoupler.
V_{cc}	8	INPUT	Power Supply Input (4.5 to 32V DC)
GND	4	INPUT	Ground

APPLICATION NOTE

A BATTERY CHARGER USING THE TSM101

This technical note shows how to use the TSM101 integrated circuit with a switching mode power supply (SMPS) to realize a battery charger.

An example of realization of a 12V Nickel-cadmium battery charger is given.

1 - TSM101 PRESENTATION

The TSM101 integrated circuit incorporates a high stability series band gap voltage reference, two ORed operational amplifiers and a current source (Figure 1)

Figure 1 : TSM101 Schematic Diagram

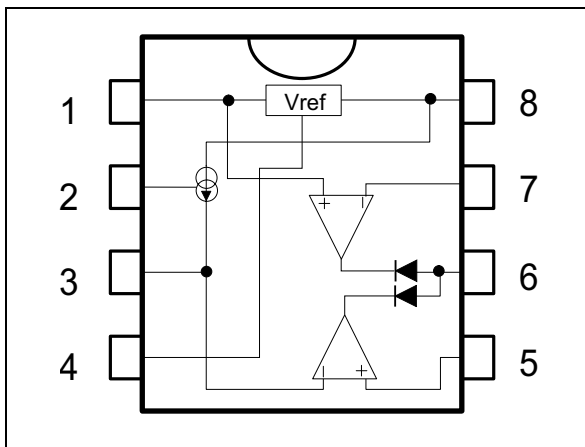

This IC compares the DC voltage and the current level at the output of a switching power supply to an internal reference. It provides a feedback through an optocoupler to the PWM controller IC in the primary side.

The controlled current generator can be used to modify the level of current limitation by offsetting the information coming from the current sensing resistor.

A great majority of low or medium end power supplies is voltage regulated by using shunt programmable voltage references like the TL431 (Figure 2).

The galvanic insulation of the control information is done by using an opto-coupler in linear mode with a variable photo current depending on the difference between the actual output voltage and the desired one.

A current limitation is used to protect the power supply against short circuits, but lacks precision. This limitation is generally realized by sensing the current of the power transistor, in the primary side of the SMPS.

The role of the TSM101 is to make a fine regulation of the output current of the SMPS and a precise voltage limitation.

The primary current limitation is conserved and acts as a security for a fail-safe operation if a short-circuit occurs at the output of the charger.

2 - PRINCIPLE OF OPERATION

The current regulation loop and the voltage limitation loop use an internal 1.24V band-gap voltage reference. This voltage reference has a good precision (better than 1.5%) and exhibits a very stable temperature behavior.

The current limitation is performed by sensing the voltage across the low ohmic value resistor R5 and comparing it to a fixed value set by the bridge composed by R2 and R3 (Figure 3).

When the voltage on R5 is higher than the voltage on R3 the output of the current loop operational amplifier decreases. The optocoupler current increases and tends to reduce the output voltage by the way of the PWM controller.

The voltage regulation is done by comparing a part of the output voltage (resistor bridge R6, R7 and P1) to the voltage reference (1.24V).

If this part is higher than 1.24V, the output of the voltage loop operational amplifier decreases.

Figure 2 : SMPS Using a TL431 as Voltage Controller

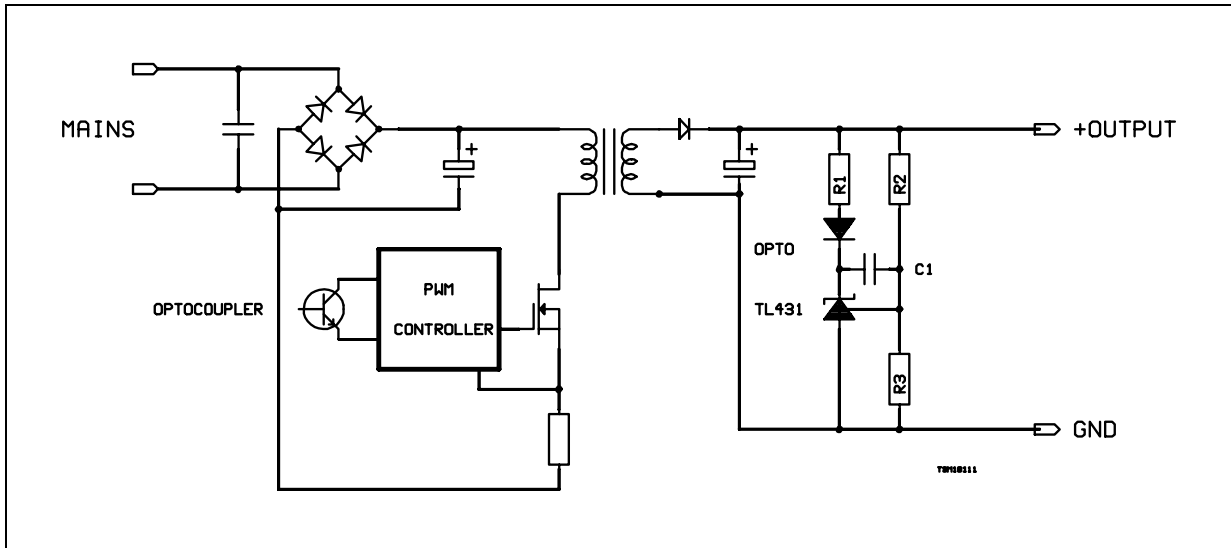

The optocoupler current increases and tends to reduce the output voltage by the way of the PWM controller.

By enabling the TSM101 current source (pin 2) it is possible to offset the current sensing by a voltage equal to :

$$V_{off} \# R4 * I_o \text{ with } I_o = 1.4\text{mA}$$

This offset lowers the output charge current and this function can be used to charge two types of batteries having different capacities. The current source is enabled by connecting pin 2 to ground

3 - CALCULATION OF THE ELEMENTS

The charge current is regulated at 700mA (if the charge control input is left open) or 200mA (if the charge control input is put to ground), allowing the charge of two different types of batteries.

3.1 - Voltage limitation

The end-of- charge voltage is limited at 1.45V/cell, this is the recommended voltage for an ambient temperature at 25oC.

A diode is generally inserted at the output of the charger to avoid the discharge of the battery if the charger is not powered. This diode is sometimes directly integrated in the battery pack. The influence of this diode on the charge is negligible if the voltage drop (0.7V) is taken into account during the design of the charger.

The voltage at the output of the charger is :

$$V_{out} = \frac{R6 + R7}{R6} \times V_r$$

and regarding R6 and R7 :

$$R6 = \left(\frac{V_{ref}}{V_{out} - V_{ref}} \right) \times R7$$

P1, which is a part of R6 and R7 is not considered in this equation.

The following values are used on the application board :

- R7 = 12kΩ
- R6 = 1kΩ
- P1 = 220Ω, adjust for $V_{output} = 15.2\text{V}$ with the battery replaced by a 1kΩ resistor
- R10 = short circuit
- C3 = 100nF

3.2 - Current regulation

R5 is the sense resistor used for current measurement.

The current regulation is effective when the voltage drop across R5 is equal to the voltage on pin 5 of the TSM101 (assuming that the internal current source is disabled).

For medium currents (<1A), a voltage drop across R5 of 200mV = Vr5 is a good value, R5 can be realized with standard low cost 0.5W resistors in parallel.

$$R5 = \frac{Vr5}{I_{ch}}, R5 = 0.285\Omega \text{ (four } 1.2\Omega \text{ resistor in parallel)}$$

R2 and R3 can be chosen using the following formula :

$$R2 = R3 \times \left(\frac{V_{ref} - Vr5}{Vr5} \right)$$

CHARGE CONTROL

If the pin 2 is left open, the charge current is nominal at # 700mA.

If pin 2 is connected to ground, the internal current source is enabled, the current measurement is off-setted by a voltage equal to :

- $V_{r4} = I_o \times R_4$ with $I_o = 1.4\text{mA}$

This can be used to lower the charging current or eventually to stop the charge, if $V_{r4} > V_{r5}$

In our example, the current offset is equal to $700 - 200\text{mA} = 500\text{mA}$, representing a voltage offset $V_{r4} = 140\text{mV}$ across R_4 .

The following values are used on the application board :

- $R_5 = 4 \times 1.2\Omega$ 0.5W in parallel
- $R_4 = 100\Omega$
- $R_2 = 1.2\text{k}\Omega$

- $R_3 = 220\Omega$
- $R_9 = \text{short circuit}$
- $R_1 = 10\text{k}\Omega$
- $C_2 = 100\text{nF}$
- $C_5 = 100\text{nF}$
- $C_1 = \text{output capacitor of the SMPS}$
- $C_4 = 10\mu\text{F}$

4 - SCHEMATIC DIAGRAM

Figure 2 represents a schematic of the output circuit of a "classical" SMPS using a TL431 for voltage regulation. This circuit is modified to use the TSM101 and the final circuit is represented in figure 3.

Figure 3 : SMPS Using the TSM101

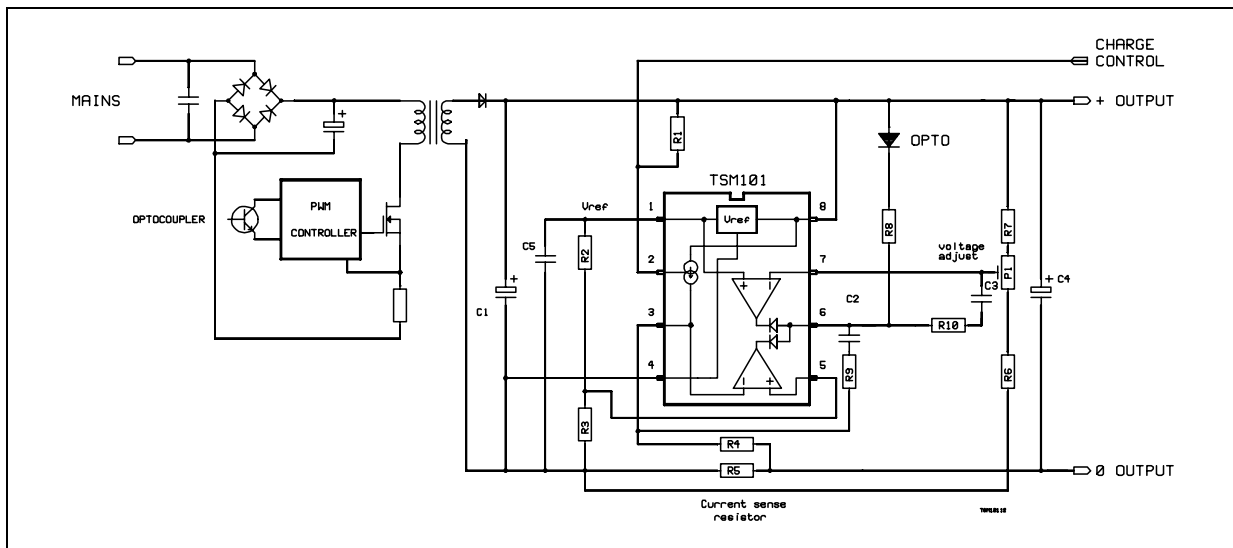

5 - IMPROVEMENT

5.1. High frequency compensation

Two R-C devices ($R_9 + C_2$ & $R_{10} + C_3$) are used to stabilize the regulation at high frequencies.

The calculation of these values is not easy and is a function of the transfer function of the SMPS.

A guess value for the capacitors C_2 and C_3 is 100nF .

5.2. Power supply for TSM101

In applications requiring low voltage battery charge or when the charger is in current regulation mode, the output voltage can be too low to supply correctly the TSM101.

The same problem occurs when the output is short-circuited.

A solution to provide a quasi constant supply voltage to the TSM101 is shown at figure 4 : an auxil-

ary winding is added at the secondary side of the transformer.

This winding is forward coupled to the primary winding, the voltage across it is directly proportional to the mains rectified voltage, even if the fly-back voltage is close to zero.

As this auxiliary winding is a voltage source, it is necessary to add a resistor (R_{11}) on the cathode of the rectifier (D_3) to limit the current.

A low cost regulator (Q_2 and Zener diode D_4) is used to power the TSM101. This is necessary with autoranging SMPS with wide input voltages, for example 90 to 240V without switching. In standard SMPS with voltage range from 200 to 240VAC or 100 to 130VAC, this regulator can be removed and replaced by the small power supply shown in figure 5 (R_{aux} , C_{aux} , D_2).

Figure 4 : An Auxiliary Winding for TSM101 Power Supply

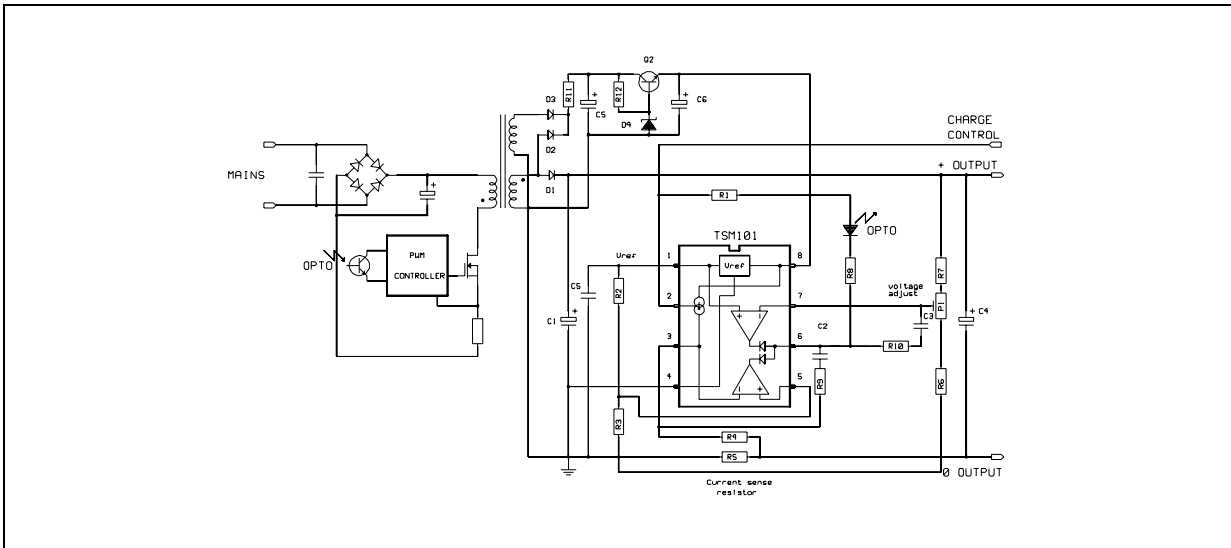

5.3. Higher Precision for the Voltage Control

The voltage drop through the sense resistor R5 offsets the voltage measurement. In most battery charging applications, this offset is not taken into account because the error is negligible compared to the end-of-charge voltage due to the fact

that the charging current value decreases drastically during the final phase of the battery charging.

But in other applications needing highest possible precision in voltage control, another connecting schematic is possible for TSM101 as shown on figure 5.

Figure 5 : Precise Output Voltage Control

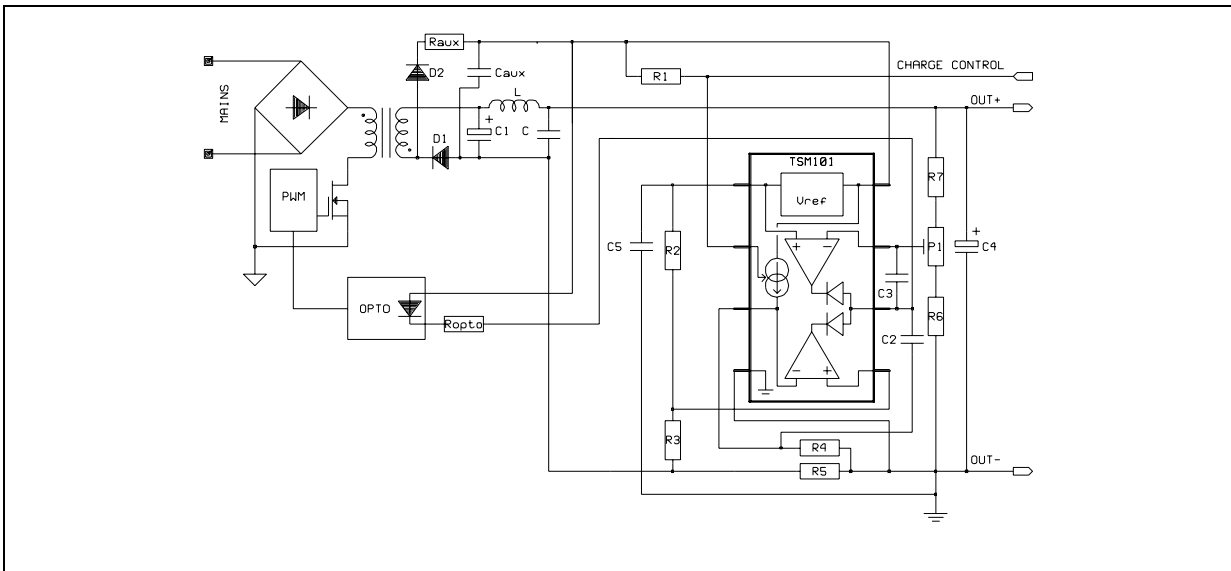

In this schematic, the 0V reference is defined as the common point between the sense resistor, the 0V Output Voltage, the foot of the resistor bridge

R6/R7, and the ground (pin 4) of the TSM101. TSM101A (1% internal voltage reference precision) is required in such applications.

5.4. An example of application where the charging current is different according to the charging phase.

The following application includes a specific recommendation which requires that the charging current should be fixed to $I_{ch1} = 800\text{mA}$ in normal charging conditions, and $I_{ch2} = 200\text{mA}$ when the cell voltage is below $V_l = 2.5\text{V}$ to optimize the cell life-time.

Moreover, an Charging Status LED should be switched off when the cell voltage is above $V_h = 6.5\text{V}$.

Figure 6 shows how this can easily be achieved using an additional dual comparator (type LM393) where the first operator (C1) is used to activate the TSM101 internal current generator to offset the current measurement thanks to R_4 , and the second (C2) is used to switch the status LED off. On figure 6, the status signal is determined by voltage measurement, this could as well be achieved by current measurement.

If $V_5 = 100\text{mV}$ is the maximum tolerable voltage drop through the sense resistor R_5 during normal charging conditions, then the following calculations apply :

Current Control :

$$R_5 = V_5 / I_{ch1} = 0.1 / 0.8 = 0.125$$

$$R_5 = 125\text{m}\Omega$$

$$V_5 = V_{ref} \times R_3 / (R_2 + R_3) \text{ with } R_2 + R_3 \sim 12\text{k}\Omega \text{ and } V_{ref} = 1.24\text{V}$$

$$R_3 = 1\text{k}\Omega, R_2 = 11.4\text{k}\Omega$$

$$V_5 = R_4 \times I_o + R_5 \times I_{ch2}, \text{ therefore, } R_4 = (V_5 - R_5 \times I_{ch2}) / I_o \text{ with } I_o = 1.4\text{mA}$$

$$R_4 = 53.6\Omega$$

$$V_{ref} = V_l \times R_{15} / (R_{14} + R_{15}) \text{ with } V_l = 2.5\text{V} \text{ and } R_{14} + R_{15} \sim 20\text{k}\Omega$$

$$R_{15} = R_{14} = 10\text{k}\Omega$$

Voltage Control :

$$V_{ref} = V_h \times R_6 / (R_6 + R_7) \text{ with } V_h = 6.5\text{V} \text{ and}$$

$$R_6 + R_7 \sim 12\text{k}\Omega$$

$$R_6 = 2.36\text{k}\Omega, R_7 = 10\text{k}\Omega$$

$$V_{ref} = V_h \times R_{17} / (R_{16} + R_{17})$$

$$R_{17} = 10\text{k}\Omega, R_{16} = 42\text{k}\Omega$$

Voltage Control :

$$V_{ref} = V_h \times R_6 / (R_6 + R_7) \text{ with } V_h = 6.5\text{V} \text{ and}$$

$$R_6 + R_7 \sim 12\text{k}\Omega$$

$$R_6 = 2.36\text{k}\Omega, R_7 = 10\text{k}\Omega$$

$$V_{ref} = V_h \times R_{17} / (R_{16} + R_{17})$$

$$R_{17} = 10\text{k}\Omega, R_{16} = 42\text{k}\Omega$$

Figure 6 : Optimized Charging Conditions

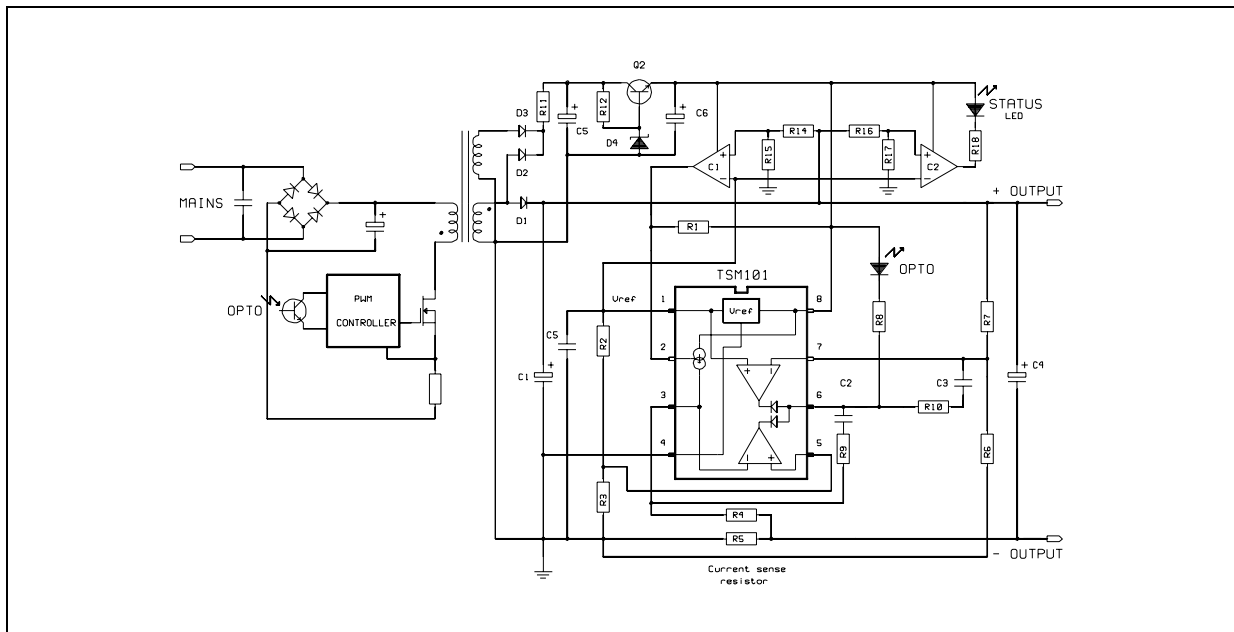

EVALUATION BOARD -TECHNICAL NOTE

TSM101 integrates in the same 8 pin DIP or SO package

- one 1.24V precision voltage reference
- two operational amplifiers
- two diodes which impose a NOR function on the outputs of the operational amplifiers
- one current source which can be activated/ inhibited thanks to an external pin.

An immediate way to take advantage of the high integration and reliability of TSM101 is to use it as a voltage and current controller on power supplies secondary. The application note AN896 describes precisely how to use TSM101 in an SMPS battery charger.

The TSM101 Evaluation Board is adaptable to any power supply or battery charger (SMPS or linear) as a voltage and current controller with minimal constraints from the user.

HOW TO USE THE TSM101 EVALUATION BOARD ?

The generic Electrical Schematic is shown on figure 1. It represents an incomplete SMPS power supply where the primary side is simplified.

Figure 1

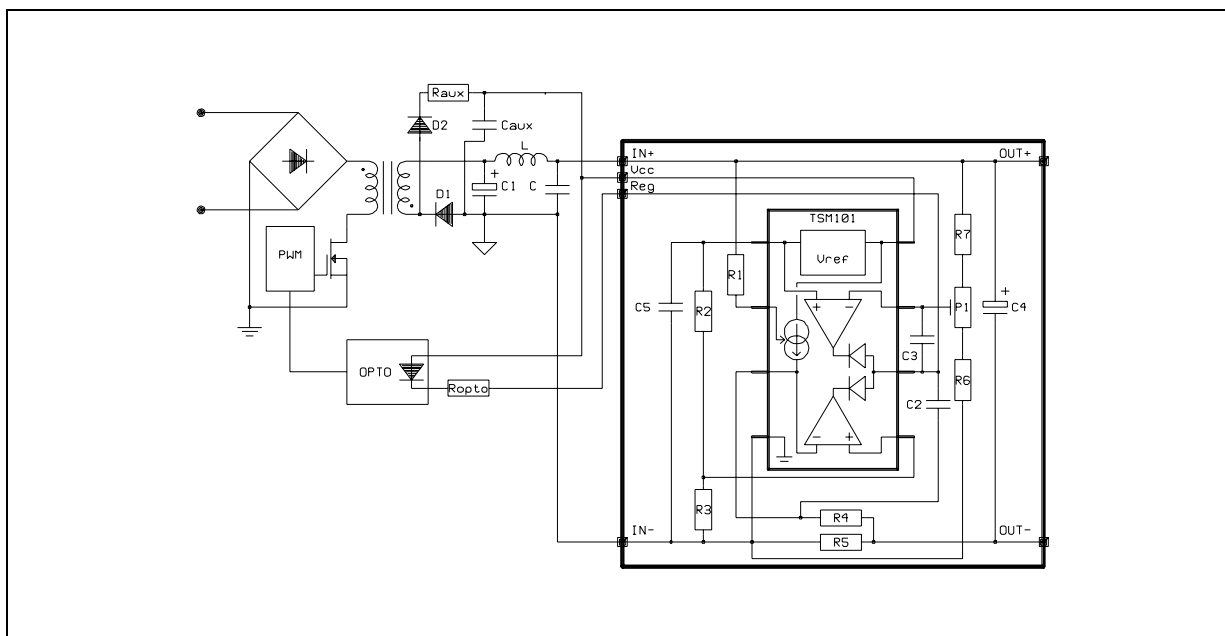

The “IN+” and “IN-” power inputs of the evaluation board should be connected directly to the power lines of the power supply secondary.

The “Vcc” input of the evaluation board should be connected to the auxiliary supply line.

In the case of an SMPS power supply, the “Reg” output of the evaluation board should be connected to the Optocoupler input to regulate the PWM block in the primary side. In the case of a linear power supply, the “Reg” output should be connected to the base of the darlington to regulate the power output.

A diode might be needed on the output of the evaluation board in the case of a battery charger application to avoid the discharge of the battery when the charger is not connected.

COMPONENTS CALCULATIONS

The voltage control is given by the choice of the resistor bridge R6/R7 (and the trimmer P1) due to equation 1 :

$$\bullet V_{ref} = \frac{R6}{(R6+R7)} \times V_{out} \quad \text{eq1}$$

where $V_{ref} = 1.24V$

The **current control** is given by the choice of the voltage drop through the sense resistor R5 (to be linked to the nominal current of the application) and by the value of the sense resistor itself.

For medium currents (< 1A), a good value for the voltage drop through R5 can be $V_{sense} = 200\text{mV}$ (dissipation < 200mW).

The resistor bridge R2/R3 should be chosen following equation 2 :

$$\bullet V_{sense} = R3/(R2+R3) \times V_{ref} \quad \text{eq2}$$

The total value of the resistor bridge should be in the range of the kW in order to ensure a proper charge for the voltage reference (in the range of the mA).

To set the current limit, the sense resistor R5 should be chosen following equation 3 :

$$\bullet I_{lim} = V_{sense}/R5 \quad \text{eq3}$$

The internal current generator (I_{sce}) can be used to offset the current limitation with a lower value.

This current generator is activated by connecting pin 2 to ground. It is inhibited if pin 2 is connected to the positive rail via the pull up resistor R1.

The current offset is given by the choice of the resistor R4.

If I_{lim1} is the current limit calculated in the previous paragraph, and I_{lim2} is the current limit that is to be set when pin 2 is connected to ground, R4 should be chosen following equation 4 :

$$\bullet R4 = (V_{sense} - I_{lim2} \times R5)/I_{sce} \quad \text{eq4}$$

where $I_{sce} = 1.4\text{mA}$

C4 and C5 are bypass capacitors used to smoothen the regulated outputs.

C2 and C3 are capacitors used for high frequency compensation.

EXAMPLES OF COMPONENT LISTS

Table 1 summarizes a few examples of component lists to generate quickly 15V/700mA/200mA, 12V/1A/500mA or 8.2V/200mA/100mA voltage and current regulations.

Voltage/ Current Control	15V 700mA 200mA	12V 1A 500mA	8.2V 200mA 100mA
R1	10kΩ	10kΩ	10kΩ
R2	1.2kΩ	1.2kΩ	1.2kΩ
R3	220kΩ	220kΩ	220kΩ
R4	100Ω	68Ω	68Ω
R5	1.2Ω x 4	0.8Ω x 4	1Ω x 1
R6	1kΩ	1kΩ	1kΩ
R7	12kΩ	8.2kΩ	5.6kΩ
P1	100Ω	100Ω	100Ω
2 straps	0Ω	0Ω	0Ω
C2	100nF	100nF	100nF
C3	100nF	100nF	100nF
C4	10μF	22μF	4.7μF
C5	100nF	100nF	100nF

Figure 2

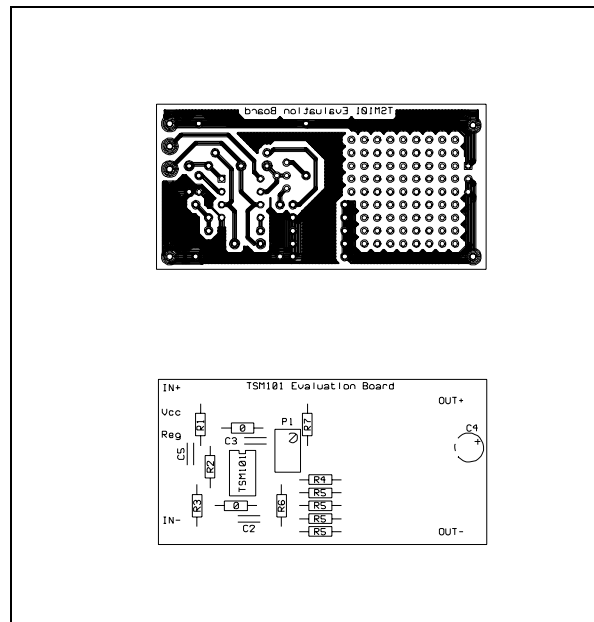

PACKAGE MECHANICAL DATA
8 PINS - PLASTIC DIP

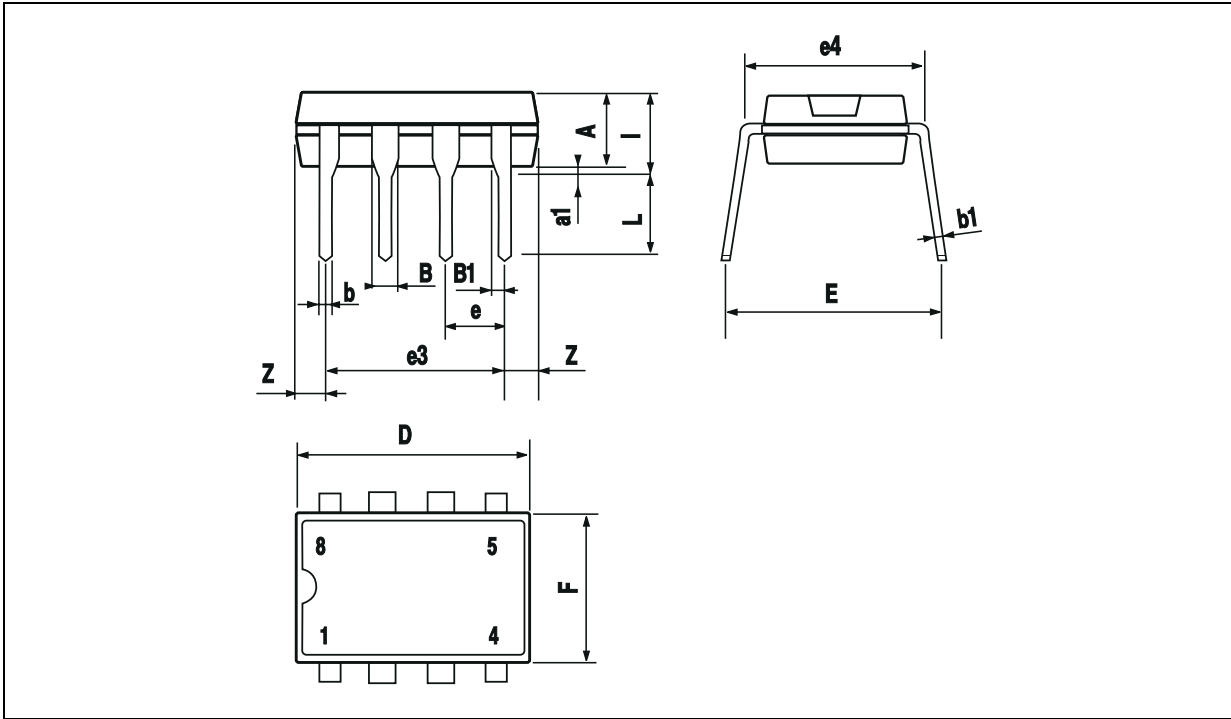

Dim.	Millimeters			Inches		
	Min.	Typ.	Max.	Min.	Typ.	Max.
A		3.32			0.131	
a1	0.51			0.020		
B	1.15		1.65	0.045		0.065
b	0.356		0.55	0.014		0.022
b1	0.204		0.304	0.008		0.012
D			10.92			0.430
E	7.95		9.75	0.313		0.384
e		2.54			0.100	
e3		7.62			0.300	
e4		7.62			0.300	
F			6.6			0.260
i			5.08			0.200
L	3.18		3.81	0.125		0.150
Z			1.52			0.060

PACKAGE MECHANICAL DATA
8 PINS - PLASTIC MICROPACKAGE (SO)

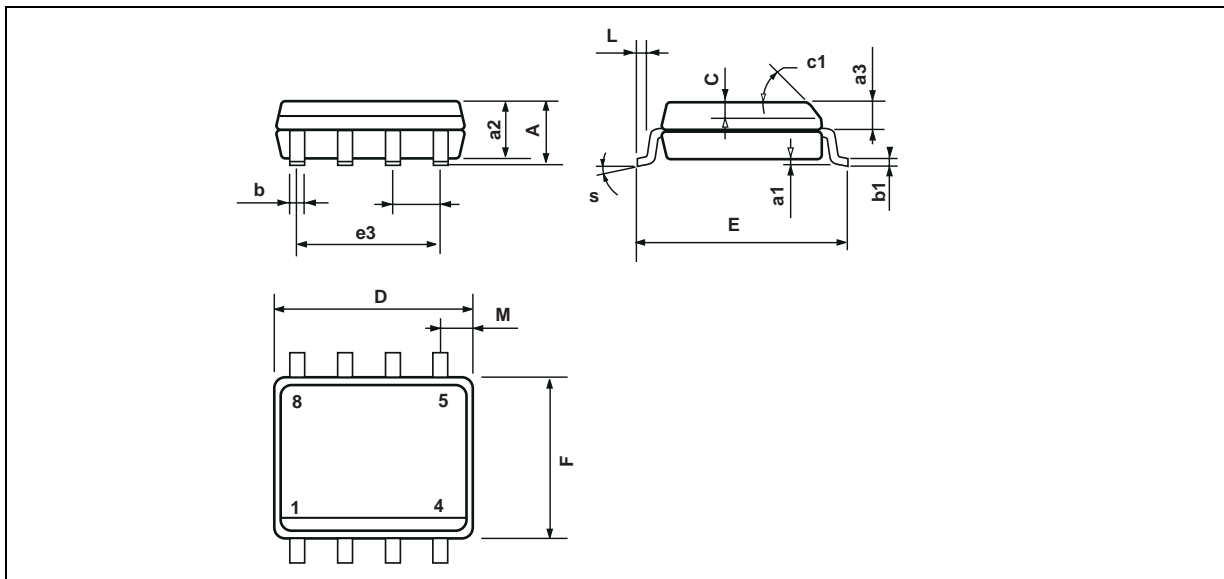

Dim.	Millimeters			Inches		
	Min.	Typ.	Max.	Min.	Typ.	Max.
A			1.75			0.069
a1	0.1		0.25	0.004		0.010
a2			1.65			0.065
a3	0.65		0.85	0.026		0.033
b	0.35		0.48	0.014		0.019
b1	0.19		0.25	0.007		0.010
C	0.25		0.5	0.010		0.020
c1	45° (typ.)					
D	4.8		5.0	0.189		0.197
E	5.8		6.2	0.228		0.244
e		1.27			0.050	
e3		3.81			0.150	
F	3.8		4.0	0.150		0.157
L	0.4		1.27	0.016		0.050
M			0.6			0.024
S	8° (max.)					

Information furnished is believed to be accurate and reliable. However, STMicroelectronics assumes no responsibility for the consequences of use of such information nor for any infringement of patents or other rights of third parties which may result from its use. No license is granted by implication or otherwise under any patent or patent rights of STMicroelectronics. Specifications mentioned in this publication are subject to change without notice. This publication supersedes and replaces all information previously supplied. STMicroelectronics products are not authorized for use as critical components in life support devices or systems without express written approval of STMicroelectronics.

© The ST logo is a registered trademark of STMicroelectronics

© 2001 STMicroelectronics - Printed in Italy - All Rights Reserved
STMicroelectronics GROUP OF COMPANIES

Australia - Brazil - China - Finland - France - Germany - Hong Kong - India - Italy - Japan - Malaysia - Malta - Morocco
 Singapore - Spain - Sweden - Switzerland - United Kingdom

© <http://www.st.com>

Looking for pricing, stock, or lifecycle information?

Click below to explore more details on WIN SOURCE:

 [View TSM101ACDTR on WIN SOURCE](#)

 [STMicroelectronics Information](#)

Optimize Your Supply Chain with WIN SOURCE Solutions

-  Global Sourcing Solution
-  Obsolete Management
-  Cost Control Management
-  Shortage Management
-  Alternative Solution
-  Excess Inventory Management