



**THE DATASHEET OF
TSM1012IDT**



Low consumption voltage and current controller for battery chargers and adapters

Datasheet - production data

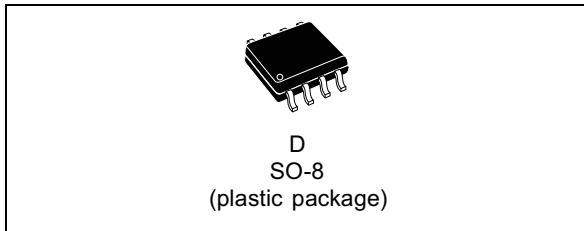

Features

- Constant voltage and constant current control
- Low consumption
- Low voltage operation
- Low external component count
- Current sink output stage
- Easy compensation
- High ac mains voltage rejection
- **Voltage reference**
 - Fixed output voltage reference 1.25 V
 - 0.5% and 1% voltage precision

Applications

- Adapters
- Battery chargers

Description

The TSM1012 is a highly integrated solution for SMPS applications requiring the CV (constant voltage) and CC (constant current) mode.

The TSM1012 device integrates one voltage reference and two operational amplifiers (with ORed outputs - common collectors).

The voltage reference combined with one operational amplifier makes it an ideal voltage controller. The other operational amplifier, combined with few external resistors and the voltage reference, can be used as a current limiter.

Figure 1. Pin connections (top view)

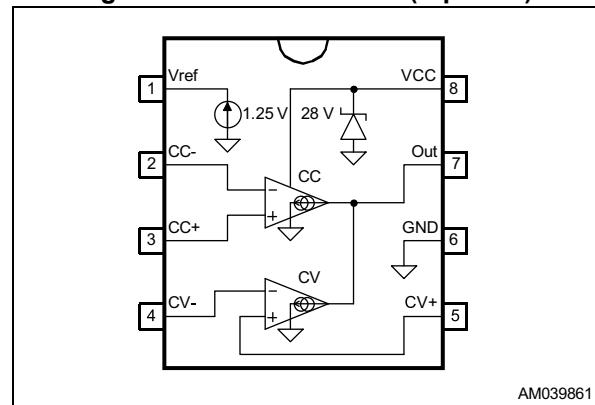

Table 1. Order codes

Part number	Temperature range	Package D ⁽¹⁾	V _{ref} (%)	Marking
TSM1012I	-40 to 105 °C	•	1	M1012
TSM1012AI	-40 to 105 °C	•	0.5	M1012A

1. D = "Small Outline" package (SO) - also available in tape and reel (DT).

Contents

1	Pin descriptions	3
2	Absolute maximum ratings	3
3	Operating conditions	3
4	Electrical characteristics	4
5	Internal schematic	6
6	Principle of operation and application hints	7
6.1	Voltage and current control	7
6.1.1	Voltage control	7
6.1.2	Current control	7
6.2	Compensation	8
6.3	Start-up and short-circuit conditions	9
6.4	Voltage clamp	9
7	Package information	11
7.1	SO-8 package information	11
8	Revision history	13

1 Pin descriptions

Table 2. SO-8 pinout

Name	Pin no.	Type	Function
V _{Ref}	1	Analog output	Voltage reference
CC-	2	Analog input	Input pin of the operational amplifier
CC+	3	Analog input	Input pin of the operational amplifier
CV-	4	Analog input	Input pin of the operational amplifier
CV+	5	Analog input	Input pin of the operational amplifier
GND	6	Power supply	Ground line. 0 V reference for all voltages.
OUT	7	Analog output	Output of the two operational amplifiers
VCC	8	Power supply	Power supply line

2 Absolute maximum ratings

Table 3. Absolute maximum ratings

Symbol	DC supply voltage	Value	Unit
VCC	DC supply voltage (50 mA =< I _{CC})	-0.3 V to Vz	V
V _i	Input voltage	-0.3 to VCC	V
T _{stg}	Storage temperature	-55 to 150	°C
T _j	Junction temperature	150	°C
I _{ref}	Voltage reference output current	2.5	mA
ESD	Electrostatic discharge	2	kV
R _{thja}	Thermal resistance junction to ambient SO-8 package	175	°C/W

3 Operating conditions

Table 4. Operating conditions

Symbol	Parameter	Value	Unit
VCC	DC supply conditions	4.5 to Vz	V
T _{oper}	Operational temperature	-40 to 105	°C

4 Electrical characteristics

$T_{amb} = 25\text{ °C}$ and $VCC = +18\text{ V}$ (unless otherwise specified).

Table 5. Electrical characteristics

Symbol	Parameter	Test condition	Min.	Typ.	Max.	Unit
Total current consumption						
I_{CC}	Total supply current, excluding current in voltage reference ⁽¹⁾ .	$VCC = 18\text{ V}$, no load $T_{min.} < T_{amb} < T_{max.}$		100	180	μA
V_z	VCC clamp voltage	$I_{CC} = 50\text{ mA}$		28		V
Operators						
V_{io}	Input offset voltage TSM1012 TSM1012A	$T_{amb} = 25\text{ °C}$ $T_{min.} \leq T_{amb} \leq T_{max.}$ $T_{amb} = 25\text{ °C}$ $T_{min.} \leq T_{amb} \leq T_{max.}$		1 0.5	4 5 2 3	mV
DV_{io}	Input offset voltage drift			7		$\mu\text{V}/\text{°C}$
I_{io}	Input offset current	$T_{amb} = 25\text{ °C}$ $T_{min.} \leq T_{amb} \leq T_{max.}$		2	30 50	nA
I_{ib}	Input bias current	$T_{amb} = 25\text{ °C}$ $T_{min.} \leq T_{amb} \leq T_{max.}$		20 50	150 200	nA
SVR	Supply voltage rejection ration	$VCC = 4.5\text{ V to }28\text{ V}$	65	100		dB
V_{icm}	Input common mode voltage range		0		$VCC - 1.5$	V
CMR	Common mode rejection ratio	$T_{amb} = 25\text{ °C}$ $T_{min.} \leq T_{amb} \leq T_{max.}$	70 60	85		dB
Output stage						
Gm	Transconduction gain. sink current only ⁽²⁾	$T_{amb} = 25\text{ °C}$ $T_{min.} \leq T_{amb} \leq T_{max.}$	0.5	1 1		mA/mV
V_{ol}	Low output voltage at 5 mA sinking current	$T_{min.} \leq T_{amb} \leq T_{max.}$		250	400	mV
I_{os}	Output short-circuit current. Output to (VCC - 0.6 V). Sink current only.	$T_{amb} = 25\text{ °C}$ $T_{min.} \leq T_{amb} \leq T_{max.}$	6 5	10		mA
Voltage reference						
V_{ref}	Reference input voltage TSM1012 1% precision TSM1012A 0.5% precision	$T_{amb} = 25\text{ °C}$ $T_{min.} \leq T_{amb} \leq T_{max.}$ $T_{amb} = 25\text{ °C}$ $T_{min.} \leq T_{amb} \leq T_{max.}$	1.238 1.225 1.244 1.237	1.25 1.25	1.262 1.273 1.256 1.261	V
ΔV_{ref}	Reference input voltage deviation over the temperature range	$T_{min.} \leq T_{amb} \leq T_{max.}$		20	30	mV

Table 5. Electrical characteristics (continued)

Symbol	Parameter	Test condition	Min.	Typ.	Max.	Unit
RegLine	Reference input voltage deviation over the VCC range.	Iload = 1 mA			20	mV
RegLoad	Reference input voltage deviation over the output current.	VCC = 18 V, 0 < Iload < 2.5 mA			10	mV

1. Test conditions: pin 2 and 6 connected to GND, pin 4 and 5 connected to 1.25 V, pin 3 connected to 200 mV.
2. The current depends on the difference voltage between the negative and the positive inputs of the amplifier. If the voltage on the minus input is 1 mV higher than the positive amplifier, the sinking current at the output OUT will be increased by $G_m \times 1 \text{ mA}$.

5 Internal schematics

Figure 2. Internal schematic

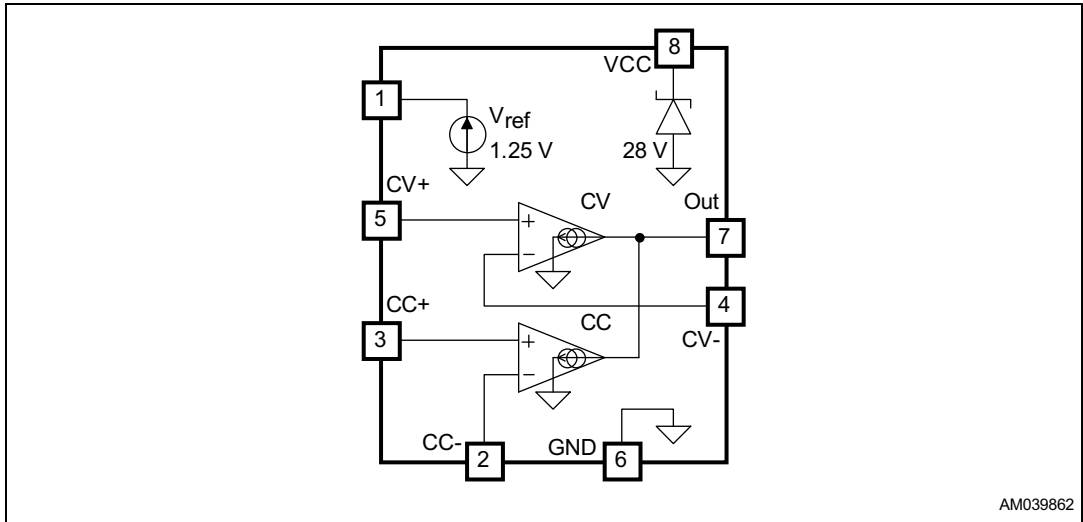

AM039862

Figure 3. Typical adapter or battery charger application using TSM1012

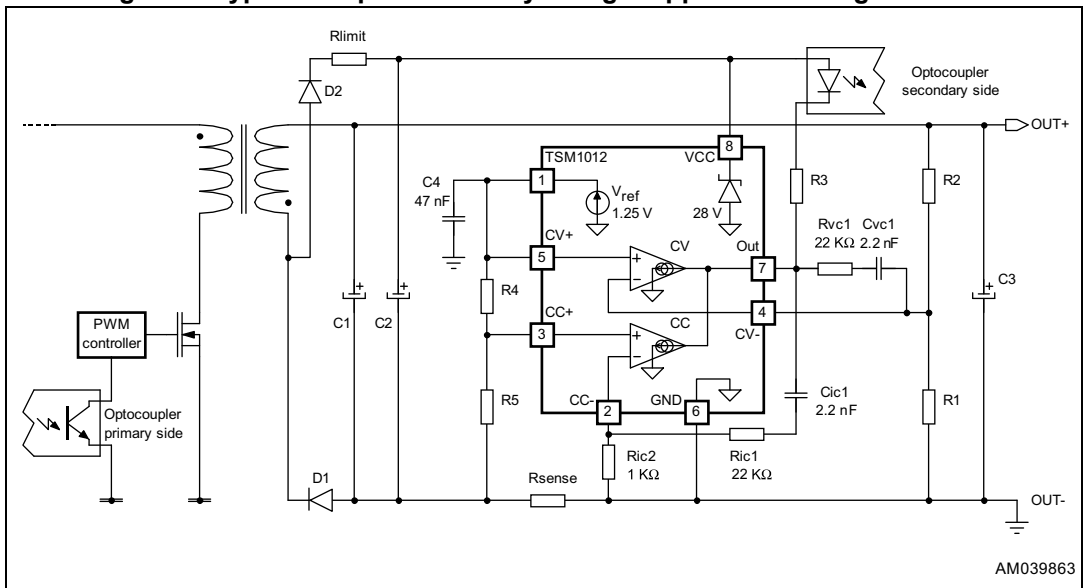

AM039863

In the application schematic shown in [Figure 3](#), the TSM1012 device is used on the secondary side of a flyback adapter (or battery charger) to provide accurate control of the voltage and current. The above feedback loop is made with an optocoupler.

6 Principle of operation and application hints

6.1 Voltage and current control

6.1.1 Voltage control

The voltage loop is controlled via a first transconductance operational amplifier, the resistor bridge R₁, R₂, and the optocoupler which is directly connected to the output.

The relation between the values of the R₁ and R₂ should be chosen as written in [Equation 1](#).

Equation 1

$$R_1 = R_2 \times V_{ref} / (V_{out} - V_{ref})$$

Where V_{out} is the desired output voltage.

To avoid the discharge of the load, the resistor bridge R₁, R₂ should be highly resistive. For this type of application, a total value of 100 KΩ (or more) would be appropriate for the resistors R₁ and R₂.

As an example, with R₂ = 100 KΩ, V_{out} = 4.10 V, V_{ref} = 1.210 V, then R₁ = 41.9 KΩ.

Note: If the low drop diode should be inserted between the load and the voltage regulation resistor bridge to avoid current flowing from the load through the resistor bridge, this drop should be taken into account in [Equation 1](#) by replacing V_{out} by $(V_{out} + V_{drop})$.

6.1.2 Current control

The current loop is controlled via the second transconductance operational amplifier, the sense resistor R_{sense}, and the optocoupler.

The V_{sense} threshold is achieved externally by a resistor bridge tied to the V_{ref} voltage reference. Its middle point is tied to the positive input of the current control operational amplifier, and its foot is to be connected to the lower potential point of the sense resistor as shown in [Figure 4](#). The resistors of this bridge are matched to provide the best precision possible.

The control equation verifies:

Equation 2

$$R_{sense} \times I_{lim} = V_{sense}$$

$$V_{sense} = R_5 \times V_{ref} / (R_4 + R_5)$$

Equation 3

$$I_{lim} = R_5 \times V_{ref} / (R_4 + R_5) \times R_{sense}$$

where I_{lim} is the desired limited current, and V_{sense} is the threshold voltage for the current control loop.

Note that the R_{sense} resistor should be chosen taking into account the maximum dissipation (P_{lim}) through it during the full load operation.

Equation 4

$$P_{lim} = V_{sense} \times I_{lim}$$

Therefore, for most adapter and battery charger applications, a quarter-watt, or half-watt resistor to make the current sensing function is sufficient.

The current sinking outputs of the two transconductance operational amplifiers are common (to the output of the IC). This makes an ORing function which ensures that whenever the current or the voltage reaches too high values, the optocoupler is activated.

The relation between the controlled current and the controlled output voltage can be described with a square characteristic as shown in the following V/I output-power graph.

Figure 4. Output voltage versus output current

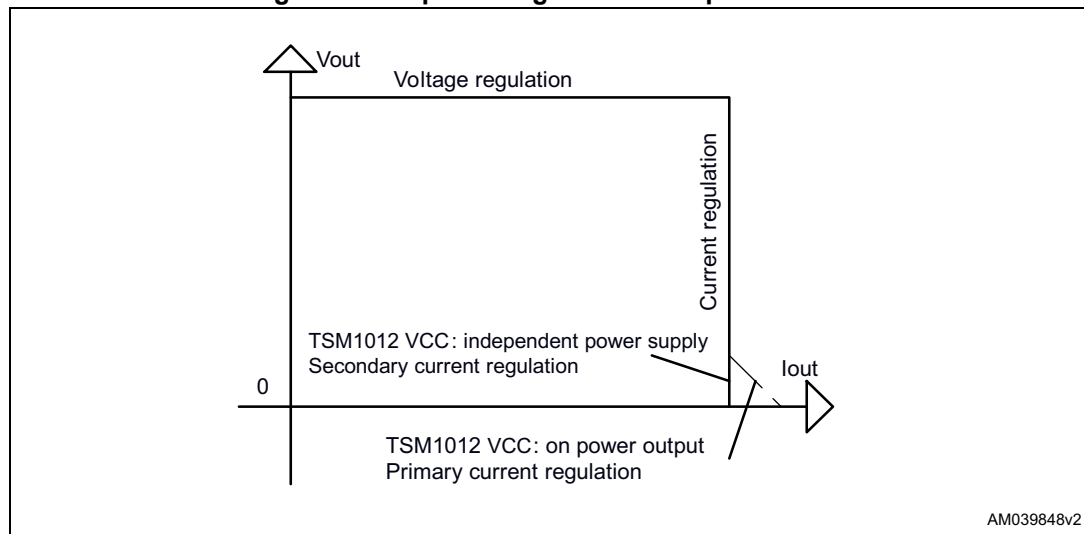

6.2 Compensation

The voltage control transconductance operational amplifier can be fully compensated. Both of its output and negative input are directly accessible for external compensation components.

An example of a suitable compensation network is shown in [Figure 6](#). It consists of a capacitor $C_{vc1} = 2.2 \text{ nF}$ and a resistor $R_{cv1} = 22 \text{ K}\Omega$ in series.

The current control trans conductance operational amplifier can be fully compensated. Both of its output and negative input are directly accessible for external compensation components.

An example of a suitable compensation network is shown in [Figure 6](#). It consists of a capacitor $C_{ic1} = 2.2 \text{ nF}$ and a resistor $R_{ic1} = 22 \text{ K}\Omega$ in series.

6.3 Start-up and short-circuit conditions

Under start-up or short-circuit conditions the TSM1012 device is not provided with a high enough supply voltage. This is due to the fact that the chip has its power supply line in common with the power supply line of the system.

Therefore, the current limitation can only be ensured by the primary PWM module, which should be chosen accordingly.

If the primary current limitation is considered not to be precise enough for the application, then a sufficient supply for the TSM1012 device has to be ensured under any condition. It would then be necessary to add some circuitry to supply the chip with a separate power line. This can be achieved in numerous ways, including an additional winding on the transformer.

6.4 Voltage clamp

Figure 6 shows how to realize a low-cost power supply for the TSM1012 device (with no additional windings). Please pay attention to the fact that in the particular case presented here, this low-cost power supply can reach voltages as high as twice the voltage of the regulated line. Since the absolute maximum rating of the TSM1012 supply voltage is 28 V. In the aim to protect the TSM1012 device against such high voltage values an internal Zener clamp is integrated.

Equation 5

$$R_{\text{limit}} = (V_{\text{CC}} - V_{\text{z}}) \times I_{\text{Vz}}$$

Figure 5. Clamp voltage

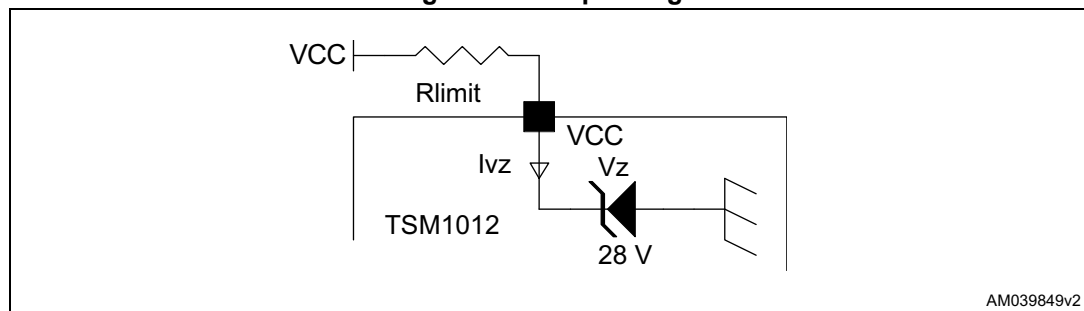
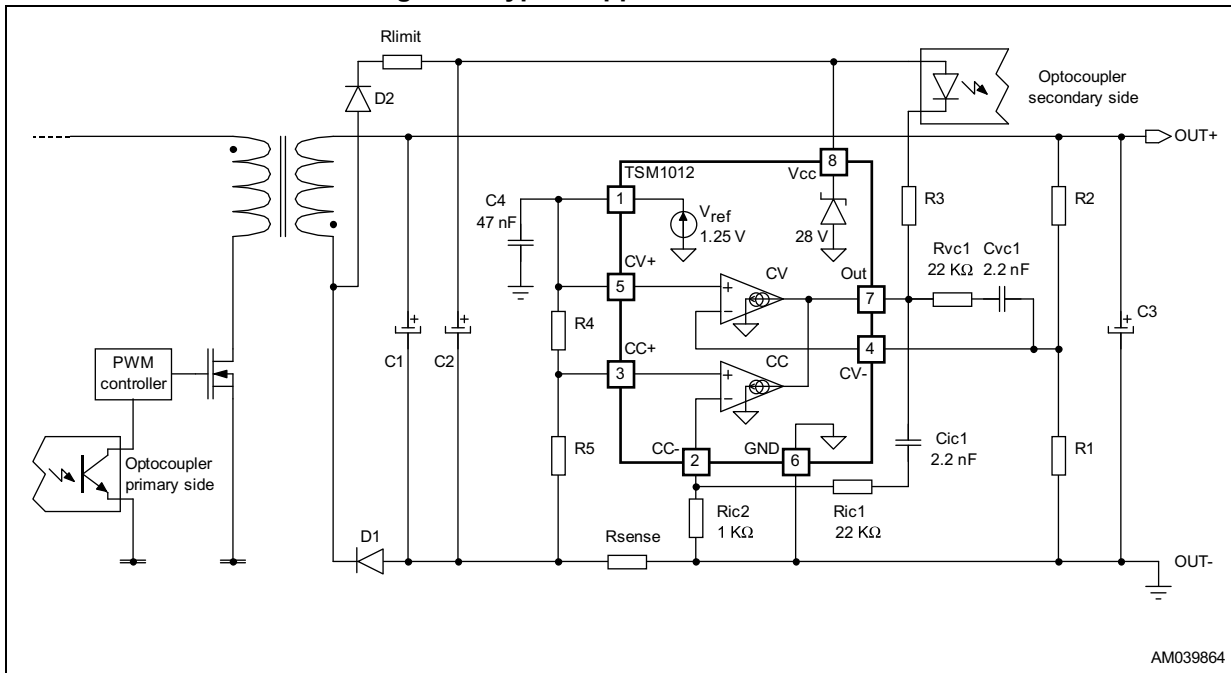

Figure 6. Typical application schematic



7 Package information

In order to meet environmental requirements, ST offers these devices in different grades of ECOPACK® packages, depending on their level of environmental compliance. ECOPACK specifications, grade definitions and product status are available at: www.st.com. ECOPACK is an ST trademark.

7.1 SO-8 package information

Figure 7. SO-8 package outline

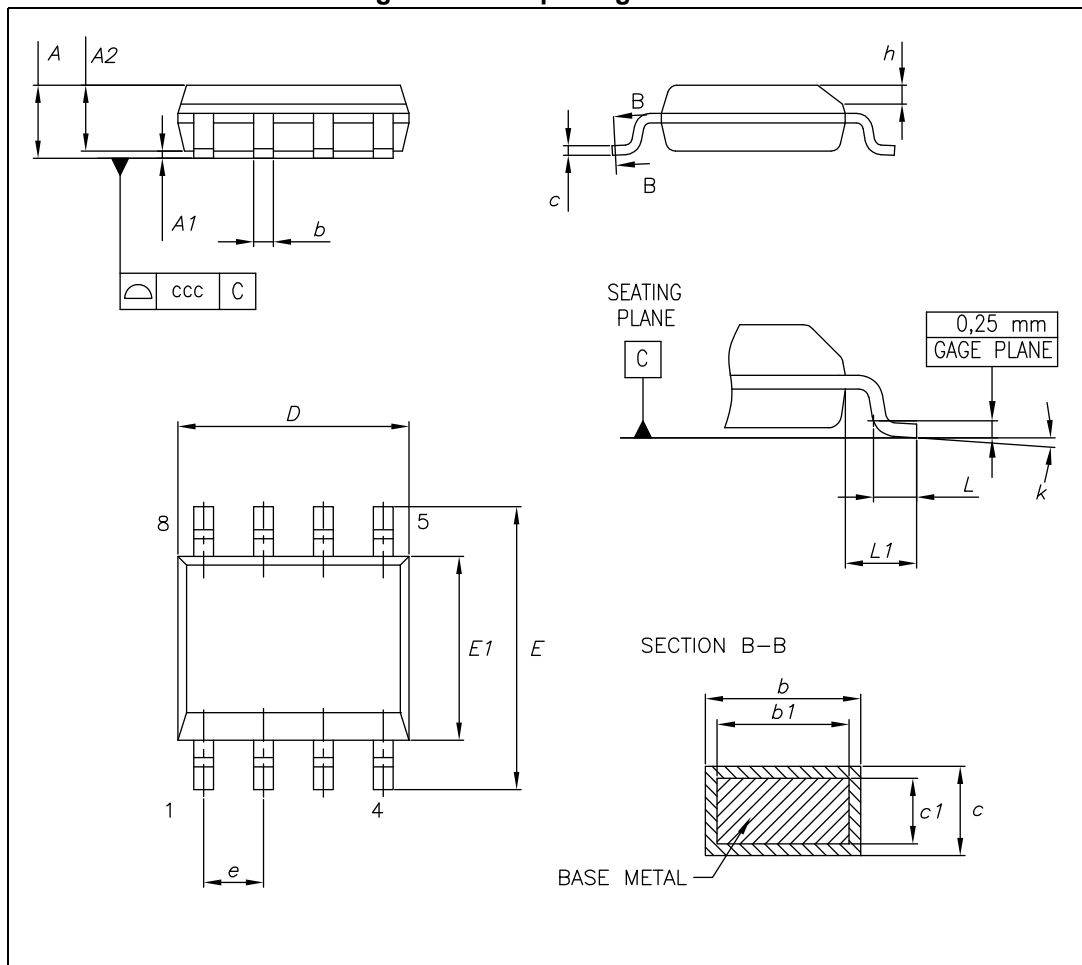

Table 6. SO-8 package mechanical data

Symbol	Dimensions (mm)		
	Min.	Typ.	Max.
A			1.75
A1	0.10		0.25
A2	1.25		
b	0.28		0.48
c	0.17		0.23
D ⁽¹⁾	4.80	4.90	5.00
E	5.80	6.00	6.20
E1 ⁽²⁾	3.80	3.90	4.00
e		1.27	
h	0.25		0.50
L	0.40		1.27
L1		1.04	
k	0°		8°
ccc			0.10

1. Dimension "D" does not include mold flash, protrusions or gate burrs. Mold flash, protrusions or gate burrs shall not exceed 0.15 mm in total (both sides).
2. Dimension "E1" does not include interlead flash or protrusions. Interlead flash or protrusions shall not exceed 0.25 mm per side.

8 Revision history

Table 7. Document revision history

Date	Revision	Changes
01-Feb-2004	1	Initial release.
15-Apr-2016	2	Removed Mini SO-8 package from the whole document. Updated Section 7: Package information on page 11 (replaced Figure 7 on page 11 by new figure, updated Table 6 on page 12). Minor modifications throughout document.

IMPORTANT NOTICE – PLEASE READ CAREFULLY

STMicroelectronics NV and its subsidiaries ("ST") reserve the right to make changes, corrections, enhancements, modifications, and improvements to ST products and/or to this document at any time without notice. Purchasers should obtain the latest relevant information on ST products before placing orders. ST products are sold pursuant to ST's terms and conditions of sale in place at the time of order acknowledgement.

Purchasers are solely responsible for the choice, selection, and use of ST products and ST assumes no liability for application assistance or the design of Purchasers' products.

No license, express or implied, to any intellectual property right is granted by ST herein.

Resale of ST products with provisions different from the information set forth herein shall void any warranty granted by ST for such product.

ST and the ST logo are trademarks of ST. All other product or service names are the property of their respective owners.

Information in this document supersedes and replaces information previously supplied in any prior versions of this document.

© 2016 STMicroelectronics – All rights reserved

Looking for pricing, stock, or lifecycle information?

Click below to explore more details on WIN SOURCE:

- ⊖ [View TSM1012IDT on WIN SOURCE](#)
- ⊖ [STMicroelectronics Information](#)

Optimize Your Supply Chain with WIN SOURCE Solutions

- ✓ Global Sourcing Solution
- ✓ Obsolete Management
- ✓ Cost Control Management
- ✓ Shortage Management
- ✓ Alternative Solution
- ✓ Excess Inventory Management