



**THE DATASHEET OF
TSB15LV01PFC**



Video Signal Processor With IEEE-1394 Link Layer Controller

FEATURES

- **Compatible With 1394 Trade Association's Digital Camera Specification, Draft 1.04**
- **1394a Link Layer Controller With 400 Mb/s Capability**
- **Support for Several CCD Sensors**
 - Sony ICX084AK, ICX098AK
 - Sharp LZ24BP
 - Texas Instruments TC237
- **Integrated CCD (Charge-Coupled Device) and CDS (Correlated Double Sampling) Pulse Timer With Programmable Pulse Skew**
- **Video Controls**
 - **Brightness (Auto/Manual)**
 - **Exposure (Auto/Manual)**
 - **Sharpness (Manual)**
 - **Saturation (Manual)**
 - **White Balance (Auto/Manual)**
 - **Gamma (Manual)**
 - **Backlight Compensation (Manual)**
- **Three Stepper Motor Controls for Focus/Zoom/Tilt or Other Motorized Functions**
- **EEPROM Interface**

- **Programmable Status/Test Terminals**
- **Seamlessly Connects to TI's 1394 Physical Layer Devices**

APPLICATIONS

- **PC Video Camera**
- **Video Conferencing**
- **Video Capture**
- **Still Picture Capture**
- **Set-Top Boxes**
- **Video Phone**
- **Gaming**
- **Webcam**
- **Robotics**
- **Security**

DESCRIPTION

The TSB15LV01 is a video signal processor integrated with a 1394 link layer controller. It is designed to be the center of a host-controlled, full-motion color camera when coupled with a 1394 PHY, CCD sensor and driver, analog front end, and an external EEPROM device. A camera based on the TSB15LV01 is compliant with the IEEE 1394a standard and the 1394 Trade Association's Digital Camera specification, Draft 1.04.

The TSB15LV01 offers the advantage of 24-bit true-color digital video processing. This gives superior video quality at higher sustained data rates. Isochronous transfer of the video data and asynchronous control of the camera are accomplished via the 1394 high-speed serial bus, operating at data rates of up to 400 Mb/s. This bus allows noncompressed full-motion digital video at rates of 30 frames/sec. Use of this serial connection eliminates the need for expensive video capture cards. The chipset supports the YUV 4:1:1, YUV 4:2:2, YUV 4:4:4, and RGB 24-bit formats.

The video signal processor (VSP) portion of the device incorporates proprietary digital image processing techniques, implemented with an advanced digital signal processing (DSP) ASIC. These techniques enable a camera to achieve excellent color accuracy and resolution. The use of a custom advanced CMOS ASIC process allows for both the advanced digital image processing techniques and for advanced color space conversion. This allows the multiple output formats required for a multipurpose video conferencing camera. Use of this advanced, low-power CMOS process also enables the camera to be powered by a notebook computer operating on battery power. The device is designed to work with CCDs that have a pixel resolution of 640(H) y 480(V). This resolution meets the VGA square pixel standards.



Please be aware that an important notice concerning availability, standard warranty, and use in critical applications of Texas Instruments semiconductor products and disclaimers thereto appears at the end of this data sheet.

The 1394 link layer controller is capable of up to 400 Mbits/s operation and is compatible with both the IEEE 1394–1995 and 1394a standards. The TSB15LV01 implements all registers and address space required by the 1394 Trade Association's Digital Camera specification, Draft 1.04 (hereafter referred to as the Digital Camera Specification).

The device supports packet speeds of up to 400 Mbits/s, but the maximum bandwidth consumed by the device is 200 Mbits/s. This means that a TSB15LV01-based camera leaves at least 200 Mbits/s available to other functions.

NOTE:

This product is for high-volume PC applications only. For a complete datasheet or more information contact support@ti.com.

PACKAGING INFORMATION

Orderable Device	Status ⁽¹⁾	Package Type	Package Drawing	Pins	Package Qty	Eco Plan ⁽²⁾	Lead/Ball Finish	MSL Peak Temp ⁽³⁾	Samples (Requires Login)
TSB15LV01IPFC	NRND	TQFP	PFC	80		TBD	Call TI	Call TI	
TSB15LV01PFC	ACTIVE	TQFP	PFC	80	96	Green (RoHS & no Sb/Br)	CU NIPDAU	Level-4-260C-72 HR	
TSB15LV01PFCG4	ACTIVE	TQFP	PFC	80	96	Green (RoHS & no Sb/Br)	CU NIPDAU	Level-4-260C-72 HR	

⁽¹⁾ The marketing status values are defined as follows:

ACTIVE: Product device recommended for new designs.

LIFEBUY: TI has announced that the device will be discontinued, and a lifetime-buy period is in effect.

NRND: Not recommended for new designs. Device is in production to support existing customers, but TI does not recommend using this part in a new design.

PREVIEW: Device has been announced but is not in production. Samples may or may not be available.

OBSOLETE: TI has discontinued the production of the device.

⁽²⁾ Eco Plan - The planned eco-friendly classification: Pb-Free (RoHS), Pb-Free (RoHS Exempt), or Green (RoHS & no Sb/Br) - please check <http://www.ti.com/productcontent> for the latest availability information and additional product content details.

TBD: The Pb-Free/Green conversion plan has not been defined.

Pb-Free (RoHS): TI's terms "Lead-Free" or "Pb-Free" mean semiconductor products that are compatible with the current RoHS requirements for all 6 substances, including the requirement that lead not exceed 0.1% by weight in homogeneous materials. Where designed to be soldered at high temperatures, TI Pb-Free products are suitable for use in specified lead-free processes.

Pb-Free (RoHS Exempt): This component has a RoHS exemption for either 1) lead-based flip-chip solder bumps used between the die and package, or 2) lead-based die adhesive used between the die and leadframe. The component is otherwise considered Pb-Free (RoHS compatible) as defined above.

Green (RoHS & no Sb/Br): TI defines "Green" to mean Pb-Free (RoHS compatible), and free of Bromine (Br) and Antimony (Sb) based flame retardants (Br or Sb do not exceed 0.1% by weight in homogeneous material)

⁽³⁾ MSL, Peak Temp. -- The Moisture Sensitivity Level rating according to the JEDEC industry standard classifications, and peak solder temperature.

Important Information and Disclaimer: The information provided on this page represents TI's knowledge and belief as of the date that it is provided. TI bases its knowledge and belief on information provided by third parties, and makes no representation or warranty as to the accuracy of such information. Efforts are underway to better integrate information from third parties. TI has taken and continues to take reasonable steps to provide representative and accurate information but may not have conducted destructive testing or chemical analysis on incoming materials and chemicals. TI and TI suppliers consider certain information to be proprietary, and thus CAS numbers and other limited information may not be available for release.

In no event shall TI's liability arising out of such information exceed the total purchase price of the TI part(s) at issue in this document sold by TI to Customer on an annual basis.

PFC (S-PQFP-G80)

PLASTIC QUAD FLATPACK

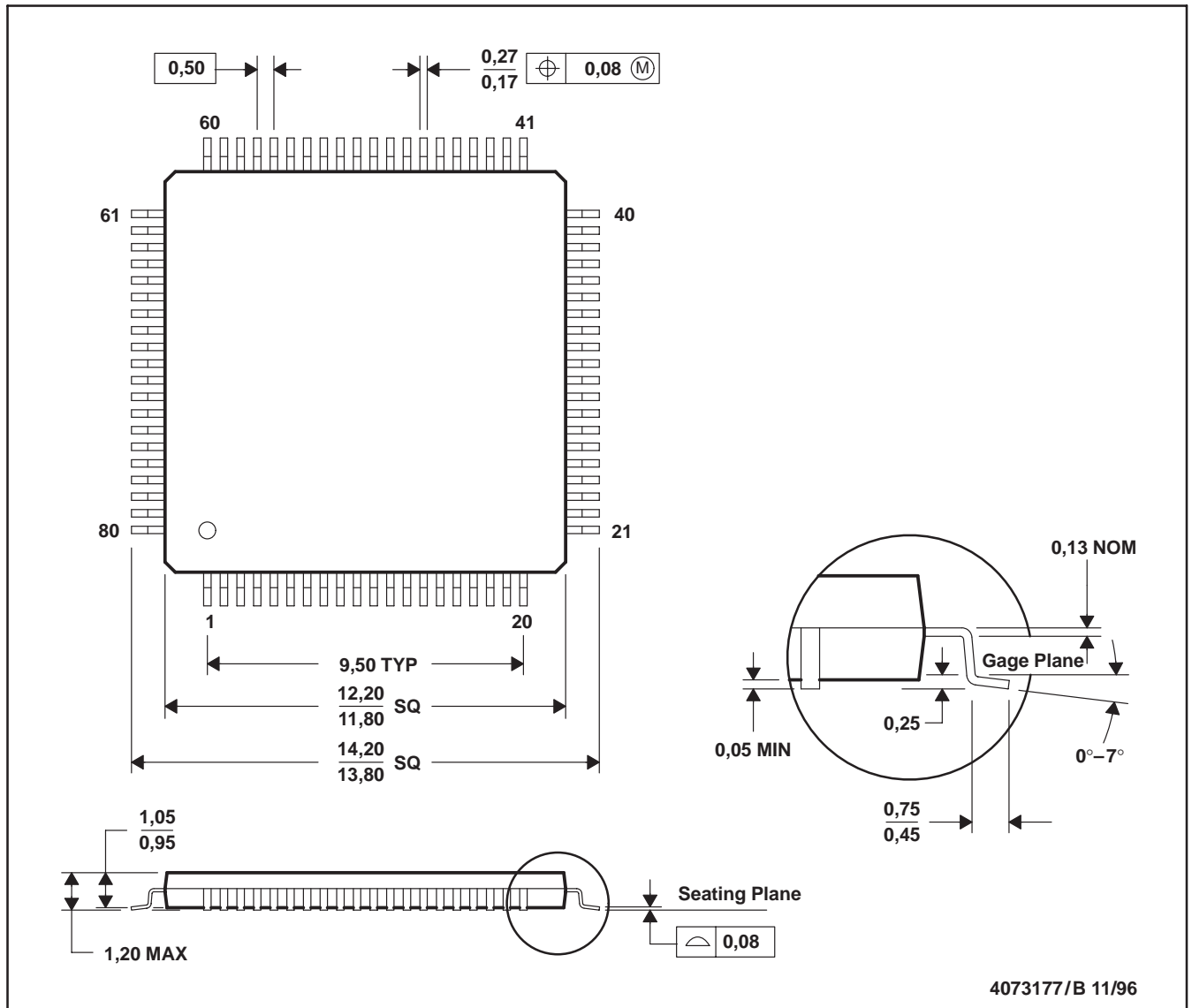

- NOTES: A. All linear dimensions are in millimeters.
 B. This drawing is subject to change without notice.
 C. Falls within JEDEC MS-026

IMPORTANT NOTICE

Texas Instruments Incorporated and its subsidiaries (TI) reserve the right to make corrections, modifications, enhancements, improvements, and other changes to its products and services at any time and to discontinue any product or service without notice. Customers should obtain the latest relevant information before placing orders and should verify that such information is current and complete. All products are sold subject to TI's terms and conditions of sale supplied at the time of order acknowledgment.

TI warrants performance of its hardware products to the specifications applicable at the time of sale in accordance with TI's standard warranty. Testing and other quality control techniques are used to the extent TI deems necessary to support this warranty. Except where mandated by government requirements, testing of all parameters of each product is not necessarily performed.

TI assumes no liability for applications assistance or customer product design. Customers are responsible for their products and applications using TI components. To minimize the risks associated with customer products and applications, customers should provide adequate design and operating safeguards.

TI does not warrant or represent that any license, either express or implied, is granted under any TI patent right, copyright, mask work right, or other TI intellectual property right relating to any combination, machine, or process in which TI products or services are used. Information published by TI regarding third-party products or services does not constitute a license from TI to use such products or services or a warranty or endorsement thereof. Use of such information may require a license from a third party under the patents or other intellectual property of the third party, or a license from TI under the patents or other intellectual property of TI.

Reproduction of TI information in TI data books or data sheets is permissible only if reproduction is without alteration and is accompanied by all associated warranties, conditions, limitations, and notices. Reproduction of this information with alteration is an unfair and deceptive business practice. TI is not responsible or liable for such altered documentation. Information of third parties may be subject to additional restrictions.

Resale of TI products or services with statements different from or beyond the parameters stated by TI for that product or service voids all express and any implied warranties for the associated TI product or service and is an unfair and deceptive business practice. TI is not responsible or liable for any such statements.

TI products are not authorized for use in safety-critical applications (such as life support) where a failure of the TI product would reasonably be expected to cause severe personal injury or death, unless officers of the parties have executed an agreement specifically governing such use. Buyers represent that they have all necessary expertise in the safety and regulatory ramifications of their applications, and acknowledge and agree that they are solely responsible for all legal, regulatory and safety-related requirements concerning their products and any use of TI products in such safety-critical applications, notwithstanding any applications-related information or support that may be provided by TI. Further, Buyers must fully indemnify TI and its representatives against any damages arising out of the use of TI products in such safety-critical applications.

TI products are neither designed nor intended for use in military/aerospace applications or environments unless the TI products are specifically designated by TI as military-grade or "enhanced plastic." Only products designated by TI as military-grade meet military specifications. Buyers acknowledge and agree that any such use of TI products which TI has not designated as military-grade is solely at the Buyer's risk, and that they are solely responsible for compliance with all legal and regulatory requirements in connection with such use.

TI products are neither designed nor intended for use in automotive applications or environments unless the specific TI products are designated by TI as compliant with ISO/TS 16949 requirements. Buyers acknowledge and agree that, if they use any non-designated products in automotive applications, TI will not be responsible for any failure to meet such requirements.

Following are URLs where you can obtain information on other Texas Instruments products and application solutions:

Products

Audio	www.ti.com/audio
Amplifiers	amplifier.ti.com
Data Converters	dataconverter.ti.com
DLP® Products	www.dlp.com
DSP	dsp.ti.com
Clocks and Timers	www.ti.com/clocks
Interface	interface.ti.com
Logic	logic.ti.com
Power Mgmt	power.ti.com
Microcontrollers	microcontroller.ti.com
RFID	www.ti-rfid.com
OMAP Mobile Processors	www.ti.com/omap
Wireless Connectivity	www.ti.com/wirelessconnectivity

Applications

Communications and Telecom	www.ti.com/communications
Computers and Peripherals	www.ti.com/computers
Consumer Electronics	www.ti.com/consumer-apps
Energy and Lighting	www.ti.com/energy
Industrial	www.ti.com/industrial
Medical	www.ti.com/medical
Security	www.ti.com/security
Space, Avionics and Defense	www.ti.com/space-avionics-defense
Transportation and Automotive	www.ti.com/automotive
Video and Imaging	www.ti.com/video

TI E2E Community Home Page

e2e.ti.com

Mailing Address: Texas Instruments, Post Office Box 655303, Dallas, Texas 75265
Copyright © 2011, Texas Instruments Incorporated

Looking for pricing, stock, or lifecycle information?

Click below to explore more details on WIN SOURCE:

 [View TSB15LV01PFC](#) on WIN SOURCE

 [Texas Instruments](#) Information

Optimize Your Supply Chain with WIN SOURCE Solutions

-  Global Sourcing Solution
-  Obsolete Management
-  Cost Control Management
-  Shortage Management
-  Alternative Solution
-  Excess Inventory Management