



# THE DATASHEET OF TS5USBA224RSWR



# USB 2.0 High-Speed (480 Mbps) and Audio Switches with Negative Signal Capability and 1.8-V Logic Compatibility

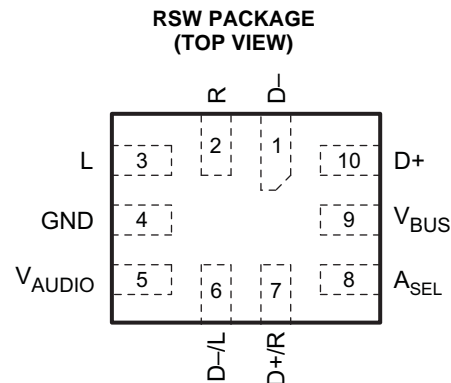
Check for Samples: [TS5USBA224](#)

## FEATURES

- **High-Speed USB Switch:**
  - 4  $\Omega$   $R_{\text{DS(on)}}$  Typical
  - 12.5 pF  $C_{\text{ON}}$  Typical
  - 650-MHz Bandwidth (–3 dB)
- **Audio Switch:**
  - 3  $\Omega$   $R_{\text{DS(on)}}$  Typical
  - Negative Rail Capability
  - Low THD: <0.05%
  - Internal Shunt Resistors for Click-and-Pop Reduction
  - Powered From  $V_{\text{AUDIO}}$  (2.7V to 5.5V)
- **1.8-V Compatible Control Input ( $A_{\text{SEL}}$  and  $V_{\text{BUS}}$ ) Threshold**
- **$I_{\text{OFF}}$  Supports Partial Powerdown Mode**
- **ESD Performance Tested Per JESD 22**
  - 2000-V Human-Body Model (A114-B, Class II)
  - 1000-V Charged-Device Model (C101)
  - 200-V Machine Model (A115-A)

## APPLICATIONS

- Cellular Phones
- Personal Digital Assistants (PDAs)
- Portable Instrumentation
- Digital Still Cameras
- Portable Navigation Devices



## DESCRIPTION

The TS5USBA224 is a double-pole, double throw (DPDT) multiplexer that includes a low-distortion audio switch and a USB 2.0 High-Speed (480Mbps) switch in the same package. This configuration allows the system designer to use a common connector for audio and USB data. The audio switch is designed to allow audio signals to swing below ground which makes this common connector configuration possible.

The TS5USBA224 is powered up using  $V_{\text{AUDIO}}$ . When  $A_{\text{SEL}}=\text{High}$ , the audio path is selected regardless of the logic level at  $V_{\text{BUS}}$ . If  $A_{\text{SEL}}=\text{Low}$  and  $V_{\text{BUS}}=\text{High}$ , the USB path is selected. Otherwise if  $A_{\text{SEL}}=\text{Low}$  and  $V_{\text{BUS}}=\text{Low}$ , the audio path is selected.

The TS5USBA224 also features shunt resistors on the audio path to reduce clicks and pops that may be heard when the audio switches are selected.

## ORDERING INFORMATION

$T_A$	PACKAGE <sup>(1)</sup> <sup>(2)</sup>		ORDERABLE PART NUMBER	TOP-SIDE MARKING
–40°C to 85°C	QFN 0.4-MM PITCH – RSW (Pb-Free)	Tape and reel	TS5USBA224RSWR	A5R

(1) Package drawings, thermal data, and symbolization are available at [www.ti.com/packaging](http://www.ti.com/packaging).

(2) For the most current package and ordering information, see the Package Option Addendum at the end of this document, or see the TI website at [www.ti.com](http://www.ti.com).



Please be aware that an important notice concerning availability, standard warranty, and use in critical applications of Texas Instruments semiconductor products and disclaimers thereto appears at the end of this data sheet.



These devices have limited built-in ESD protection. The leads should be shorted together or the device placed in conductive foam during storage or handling to prevent electrostatic damage to the MOS gates.

### SUMMARY OF TYPICAL CHARACTERISTICS

	USB PATH	AUDIO PATH
Number of switches	2	2
ON-state resistance ( $r_{on}$ )	4 $\Omega$	3 $\Omega$
ON-state resistance match ( $\Delta r_{on}$ )	< 0.3 $\Omega$	< 0.3 $\Omega$
ON-state resistance flatness ( $r_{on(flat)}$ )	N/A	1.5 $\Omega$
Turn-on/turn-off time ( $t_{on}/t_{off}$ )	< 2 $\mu$ s	< 4 $\mu$ s
Bandwidth (BW)	650 MHz	N/A
OFF isolation ( $O_{ISO}$ )	-22 dB	-83 dB
Crosstalk ( $X_{TALK}$ )	-31 dB	-83 dB
Total harmonic distortion (THD)	N/A	0.05%

### PIN DESCRIPTION TABLE

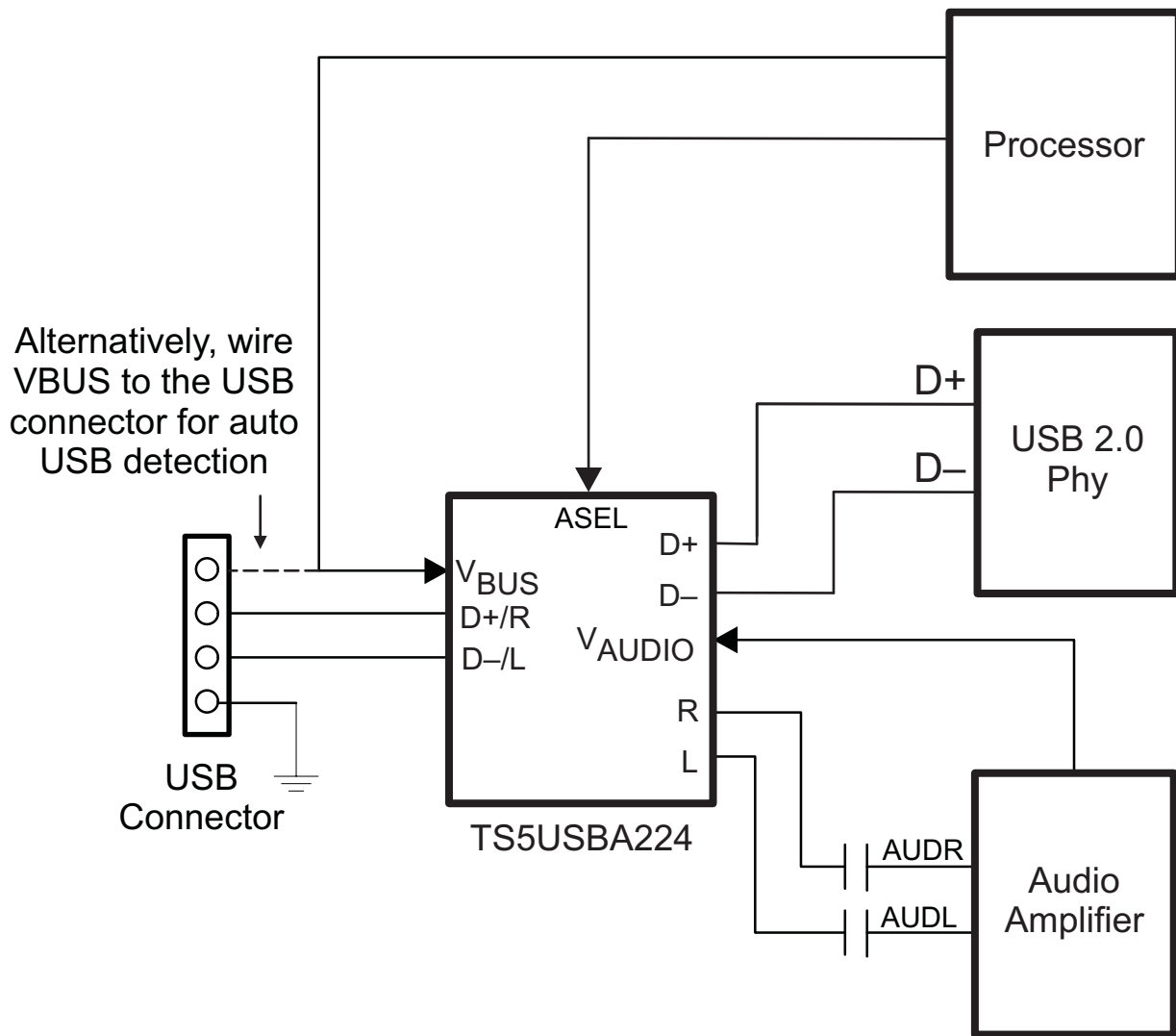
PIN			DESCRIPTION
NO.	NAME	TYPE	
1	D-	I/O	USB Data (Differential -)
2	R	I/O	Right Channel Audio
3	L	I/O	Left Channel Audio
4	GND	Ground	Ground
5	V <sub>AUDIO</sub>	Power	Supply Voltage
6	D-/L	I/O	USB/Audio Common Connector
7	D+/R	I/O	USB/Audio Common Connector
8	A <sub>SEL</sub>	Input	Control Input for Audio Path
9	V <sub>BUS</sub>	Input	Control Input for USB Path
10	D+	I/O	USB Data (Differential +)

FUNCTION TABLE

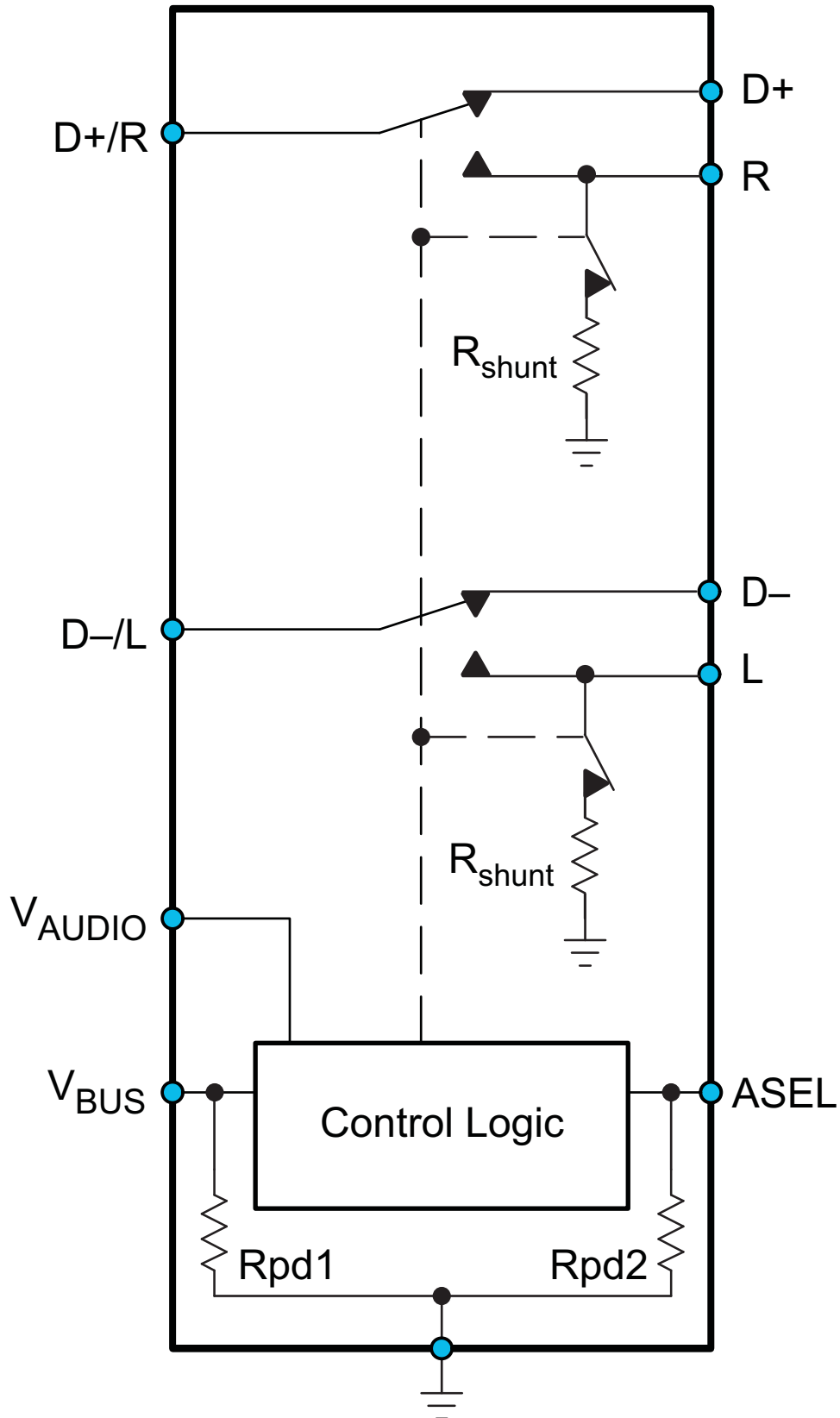
ASEL	V <sub>AUDIO</sub>	V <sub>BUS</sub>	L,R	D+, D-
L	L	L	OFF	OFF
L	L	H	OFF	OFF
L	H	L	ON	OFF
L	H	H	OFF <sup>(1)</sup>	ON
H	L	L	OFF	OFF
H	L	H	OFF	OFF
H	H	L	ON	OFF
H	H	H	ON	OFF

(1) 100Ω shunt resistors are enabled in this state.

TYPICAL APPLICATION BLOCK DIAGRAM



SWITCH BLOCK DIAGRAM



**ABSOLUTE MAXIMUM RATINGS<sup>(1)(2)</sup>**

over operating free-air temperature range (unless otherwise noted)

		MIN	MAX	UNIT
V <sub>AUDIO</sub>	Supply voltage range <sup>(3)</sup>	-0.5	6.5	V
V <sub>D+</sub> V <sub>D-</sub>	Analog voltage Range <sup>(3)</sup>	-0.5	6.5	V
V <sub>R</sub> V <sub>L</sub>		V <sub>AUDIO</sub> - 6.5	V <sub>AUDIO</sub> + 0.5	V
I <sub>K</sub>	Analog port diode current	V <sub>D+</sub> , V <sub>D-</sub> < 0		mA
I <sub>D+</sub> , I <sub>D-</sub> I <sub>R</sub> , I <sub>L</sub>	ON-state switch current	V <sub>D+</sub> , V <sub>D-</sub> = 0 to V <sub>AUDIO</sub> , V <sub>R</sub> , V <sub>L</sub> V <sub>D+/R</sub> , V <sub>D-/L</sub> = V <sub>AUDIO</sub> - 5.5 V to V <sub>AUDIO</sub>		mA
I <sub>D+/R</sub> I <sub>D-/L</sub>	ON-state peak switch current <sup>(4)</sup>	-200	200	
V <sub>I</sub>	Digital input voltage range	-0.5	6.5	V
I <sub>IK</sub>	Digital logic input clamp current <sup>(3)</sup>	V <sub>I</sub> < 0		mA
I <sub>AUDIO</sub>	Continuous current through V <sub>AUDIO</sub>		100	mA
I <sub>GND</sub>	Continuous current through GND	-100		mA
T <sub>stg</sub>	Storage temperature range	-65	150	°C

- (1) Stresses beyond those listed under "absolute maximum ratings" may cause permanent damage to the device. These are stress ratings only, and functional operation of the device at these or any other conditions beyond those indicated under "recommended operating conditions" is not implied. Exposure to absolute-maximum-rated conditions for extended periods may affect device reliability.
- (2) The algebraic convention, whereby the most negative value is a minimum and the most positive value is a maximum.
- (3) All voltages are with respect to ground, unless otherwise specified.
- (4) Pulse at 1-ms duration <10% duty cycle.

**PACKAGE THERMAL IMPEDANCE<sup>(1)</sup>**

over operating free-air temperature range (unless otherwise noted)

PARAMETER	TEST CONDITIONS	TYP	UNIT
θ <sub>JA</sub>	Package thermal impedance RSW package	175	°C/W

- (1) The package thermal impedance is calculated in accordance with JESD 51-7.

**ELECTRICAL CHARACTERISTICS**

T<sub>A</sub> = -40°C to 85°C, typical values are at V<sub>AUDIO</sub> = 3.3 V, T<sub>A</sub> = 25°C (unless otherwise noted)

PARAMETER	TEST CONDITIONS	MIN	TYP	MAX	UNIT
<b>USB SWITCH</b>					
V <sub>D+</sub> , V <sub>D-</sub>	Analog voltage range	0		5.5	V
r <sub>on</sub>	ON-state resistance	V <sub>AUDIO</sub> = 3 V, V <sub>BUS</sub> = 5 V, V <sub>ASEL</sub> = 0 V, V <sub>D+/D-</sub> = 0 V, 0.4 V, I <sub>ON</sub> = -8 mA		Switch ON	4 7 Ω
Δr <sub>on</sub>	ON-state resistance match between channels	V <sub>AUDIO</sub> = 3 V, V <sub>BUS</sub> = 5 V, V <sub>ASEL</sub> = 0 V, V <sub>D+/D-</sub> = 0 V, 0.4 V, I <sub>ON</sub> = -8 mA		Switch ON	0.3 Ω
I <sub>D+(OFF)</sub> I <sub>D-(OFF)</sub>	D+ ,D- OFF leakage current	V <sub>AUDIO</sub> = 3.6 V, V <sub>BUS</sub> = 0 V, V <sub>ASEL</sub> = 3.6 V, V <sub>D+</sub> , V <sub>D-</sub> = 0.3 V, V <sub>D+/R</sub> , V <sub>D-/L</sub> = 0.3 V		Switch OFF	±50 nA
I <sub>D+(ON)</sub> I <sub>D-(ON)</sub>	D+ ,D- ON leakage current	V <sub>AUDIO</sub> = 3.6 V, V <sub>BUS</sub> = 5 V, V <sub>ASEL</sub> = 0 V, V <sub>D+</sub> , V <sub>D-</sub> = 0.3 V, V <sub>D+/R</sub> = Open		Switch ON	±50 nA
<b>AUDIO SWITCH</b>					
V <sub>R</sub> , V <sub>L</sub>	Analog voltage range	V <sub>AUDIO</sub> - 5.5		V <sub>AUDIO</sub>	V
r <sub>on</sub>	ON-state resistance	V <sub>AUDIO</sub> = 3 V, V <sub>BUS</sub> = 0 V, V <sub>ASEL</sub> = 3 V, V <sub>L/R</sub> = -2 V, 0 V, 0.7 V, I <sub>ON</sub> = -26 mA		Switch ON	3 5 Ω
Δr <sub>on</sub>	ON-state resistance match between channels	V <sub>AUDIO</sub> = 3 V, V <sub>BUS</sub> = 0 V, V <sub>ASEL</sub> = 3 V, V <sub>L/R</sub> = 0.7 V, I <sub>ON</sub> = -26 mA		Switch ON	0.3 Ω
r <sub>on</sub> (flat)	ON-state resistance flatness	V <sub>AUDIO</sub> = 3 V, V <sub>BUS</sub> = 0 V, V <sub>ASEL</sub> = 3 V, V <sub>L/R</sub> = -2 V, 0 V, 0.7 V, I <sub>ON</sub> = -26 mA		Switch ON	1.5 2.5 Ω

**ELECTRICAL CHARACTERISTICS (continued)**

$T_A = -40^\circ\text{C}$  to  $85^\circ\text{C}$ , typical values are at  $V_{\text{AUDIO}} = 3.3\text{ V}$ ,  $T_A = 25^\circ\text{C}$  (unless otherwise noted)

PARAMETER		TEST CONDITIONS		MIN	TYP	MAX	UNIT
$r_{\text{SHUNT}}$	Shunt resistance	$V_{\text{AUDIO}} = 3\text{ V}$ , $V_{\text{BUS}} = 5\text{ V}$ , $V_{\text{ASEL}} = 0\text{ V}$ , $V_{\text{L/R}} = 0.7\text{ V}$ , $I_{\text{OSHUNT}} = 10\text{ mA}$	Switch OFF		100	200	$\Omega$
$I_{\text{L(OFF)}}$ $I_{\text{R(OFF)}}$	L, R OFF leakage current	$V_{\text{AUDIO}} = 3.6\text{ V}$ , $V_{\text{BUS}} = 5\text{ V}$ , $V_{\text{ASEL}} = 0\text{ V}$ , $V_{\text{R}}, V_{\text{L}} = 0.3\text{ V}$ , $V_{\text{AUDIO}} - 0.3\text{ V}$ , $V_{\text{D+R}}, V_{\text{D-L}} = 0.3\text{ V}$ , $V_{\text{AUDIO}} - 0.3\text{ V}$	Switch OFF			$\pm 50$	nA
$I_{\text{L(ON)}}$ $I_{\text{R(ON)}}$	L, R ON leakage current	$V_{\text{AUDIO}} = 3.6\text{ V}$ , $V_{\text{BUS}} = 0\text{ V}$ , $V_{\text{ASEL}} = 3.6\text{ V}$ , $V_{\text{D+R}}, \text{D-L} = 0.3\text{ V}$ , $V_{\text{R}}, V_{\text{L}} = 0.3\text{ V}$ , $V_{\text{AUDIO}} - 0.3\text{ V}$ , $V_{\text{AUDIO}} - 0.3\text{ V}$ $V_{\text{D+R}}, V_{\text{D-L}} = \text{Open}$	Switch ON			$\pm 50$	nA
<b>DIGITAL CONTROL INPUTS (<math>A_{\text{SEL}}</math>, <math>V_{\text{BUS}}</math>)</b>							
$V_{\text{IH}}$	Input logic high	$V_{\text{AUDIO}} = 2.7\text{V to } 5.5\text{V}$		1.2			V
$V_{\text{IL}}$	Input logic low	$V_{\text{AUDIO}} = 2.7\text{V to } 5.5\text{V}$				0.5	V
$I_{\text{IN}}$	Input leakage current	$V_{\text{AUDIO}} = 3.6\text{V}$	$V_{\text{IN}} = 3.6\text{V}$			$\pm 10$	$\mu\text{A}$
			$V_{\text{IN}} = 0\text{V}$			$\pm 1$	
$r_{\text{PD1}}$	Internal pulldown resistance				3		$\text{M}\Omega$
$r_{\text{PD2}}$	Internal pulldown resistance				5		$\text{M}\Omega$

## DYNAMIC CHARACTERISTICS

 $T_A = -40^{\circ}\text{C}$  to  $85^{\circ}\text{C}$ , typical values are at  $V_{\text{AUDIO}} = 3.3\text{ V}$ ,  $T_A = 25^{\circ}\text{C}$  (unless otherwise noted)

PARAMETER		TEST CONDITIONS	MIN	TYP	MAX	UNIT
<b>USB SWITCH</b>						
$t_{\text{ON}}$	Turn-on time	$V_{\text{AUDIO}} = 3\text{ V}$ , $V_{\text{BUS}} = 0\text{ V}$ to $5\text{ V}$ , $V_{\text{ASEL}} = 0\text{ V}$ , $V_{\text{D+R, D-L}} = 1\text{ V}$ , <a href="#">Figure 10</a>		2		$\mu\text{s}$
$t_{\text{OFF}}$	Turn-off time	$V_{\text{AUDIO}} = 3\text{ V}$ , $V_{\text{BUS}} = 5\text{ V}$ to $0\text{ V}$ , $V_{\text{ASEL}} = 0\text{ V}$ , $V_{\text{D+R, D-L}} = 1\text{ V}$ , <a href="#">Figure 10</a>		1		$\mu\text{s}$
$t_{\text{SK(O)}}$	Channel-to-channel skew	$f = 240\text{ MHz}$ , <a href="#">Figure 11</a>		35		ps
$t_{\text{SK(P)}}$	Skew of opposite transitions of same output	$f = t\ 240\text{ MHz}$ , <a href="#">Figure 11</a>		25		ps
$C_{\text{D+(OFF)}}$ $C_{\text{D-(OFF)}}$	D+, D-OFF capacitance	$V_{\text{AUDIO}} = 3\text{ V}$ , $V_{\text{BUS}} = 0\text{ V}$ , $A_{\text{SEL}} = 3\text{ V}$ , $f = 240\text{ MHz}$	Switch OFF	2.8		pF
$C_{\text{D+(ON)}}$ $C_{\text{D-(ON)}}$	D+, D- ON capacitance	$V_{\text{AUDIO}} = 3\text{ V}$ , $V_{\text{BUS}} = 5\text{ V}$ , $A_{\text{SEL}} = 0\text{ V}$ , $f = 240\text{ MHz}$	Switch ON	12.5		pF
$C_{\text{I}}$	Digital input capacitance	$V_{\text{AUDIO}} = 3\text{ V}$ , $V_{\text{BUS}} = 0\text{ V}$ , $A_{\text{SEL}} = 0\text{ V}$ , $f = 1\text{ MHz}$		2.2		pF
BW	Bandwidth	$V_{\text{AUDIO}} = 3\text{ V}$ , $V_{\text{BUS}} = 5\text{ V}$ , $V_{\text{ASEL}} = 0\text{ V}$ , <a href="#">Figure 12</a>	Switch ON	650		MHz
$O_{\text{ISO}}$	OFF Isolation	$V_{\text{AUDIO}} = 3\text{ V}$ , $V_{\text{BUS}} = 0\text{ V}$ , $V_{\text{ASEL}} = 3\text{ V}$ , $R_{\text{L}} = 50\ \Omega$ , $f = 240\text{ MHz}$ , <a href="#">Figure 14</a>	Switch OFF	-22		dB
$X_{\text{TALK}}$	Crosstalk	$V_{\text{AUDIO}} = 3\text{ V}$ , $V_{\text{BUS}} = 5\text{ V}$ , $V_{\text{ASEL}} = 0\text{ V}$ , $R_{\text{L}} = 50\ \Omega$ , $f = 240\text{ MHz}$ , <a href="#">Figure 13</a>	Switch ON	-31		dB
<b>AUDIO SWITCH</b>						
$t_{\text{ON}}$	Turn-on time	$V_{\text{AUDIO}} = 3\text{ V}$ , $V_{\text{BUS}} = 0\text{ V}$ or $5\text{ V}$ , $V_{\text{ASEL}} = 0\text{ V}$ to $3\text{ V}$ , $V_{\text{D+R, D-L}} = 1\text{ V}$ , <a href="#">Figure 10</a>		4		$\mu\text{s}$
$t_{\text{OFF}}$	Turn-off time	$V_{\text{AUDIO}} = 3\text{ V}$ , $V_{\text{BUS}} = 0\text{ V}$ , $V_{\text{ASEL}} = 3\text{ V}$ to $0\text{ V}$ , $V_{\text{D+R, D-L}} = 1\text{ V}$ , <a href="#">Figure 10</a>		1		$\mu\text{s}$
$C_{\text{L(OFF)}}$ $C_{\text{R(OFF)}}$	L, R OFF capacitance	$V_{\text{AUDIO}} = 3\text{ V}$ , $V_{\text{BUS}} = 5\text{ V}$ , $V_{\text{ASEL}} = 0\text{ V}$ , $f = 20\text{ kHz}$	Switch OFF	4.5		pF
$C_{\text{L(ON)}}$ $C_{\text{R(ON)}}$	L, R ON capacitance	$V_{\text{AUDIO}} = 3\text{ V}$ , $V_{\text{BUS}} = 0\text{ V}$ , $V_{\text{ASEL}} = 3\text{ V}$ , $f = 20\text{ kHz}$	Switch ON	15		pF
$O_{\text{ISO}}$	OFF Isolation	$V_{\text{AUDIO}} = 3\text{ V}$ , $V_{\text{BUS}} = 5\text{ V}$ , $V_{\text{ASEL}} = 0\text{ V}$ , $R_{\text{L}} = 50\ \Omega$ , $f = 20\text{ kHz}$ , <a href="#">Figure 14</a>	Switch OFF	-83		dB
$X_{\text{TALK}}$	Crosstalk	$V_{\text{AUDIO}} = 3\text{ V}$ , $V_{\text{BUS}} = 0\text{ V}$ , $V_{\text{ASEL}} = 3\text{ V}$ , $R_{\text{L}} = 50\ \Omega$ , $f = 20\text{ kHz}$ , <a href="#">Figure 13</a>	Switch ON	-83		dB
THD	Total harmonic distortion	$V_{\text{AUDIO}} = 3\text{ V}$ , $V_{\text{BUS}} = 0\text{ V}$ , $V_{\text{ASEL}} = 3\text{ V}$ , $f = 20\text{ Hz}$ to $20\text{ kHz}$ , $R_{\text{L}} = 600\ \Omega$ , $V_{\text{IN}} = 2\text{ Vpp}$		0.05		%
<b>SUPPLY</b>						
$V_{\text{AUDIO}}$	Power supply voltage			2.7	5.5	V
$I_{\text{AUDIO}}$	Positive supply current	$V_{\text{AUDIO}} = 3.6\text{ V}$ , $V_{\text{BUS}} = 0$ or $5\text{ V}$ , $V_{\text{ASEL}} = 0$ to $3.6\text{ V}$ , $I_{\text{OUT}} = 0$		6	10	$\mu\text{A}$
$I_{\text{OFF}}$	Power off leakage current	$V_{\text{AUDIO}} = 0\text{ V}$ , $V_{\text{D+R, D-L, D+, D-, L, R}} = 0$ to $5.5\text{ V}$			$\pm 10$	$\mu\text{A}$

TYPICAL CHARACTERISTICS

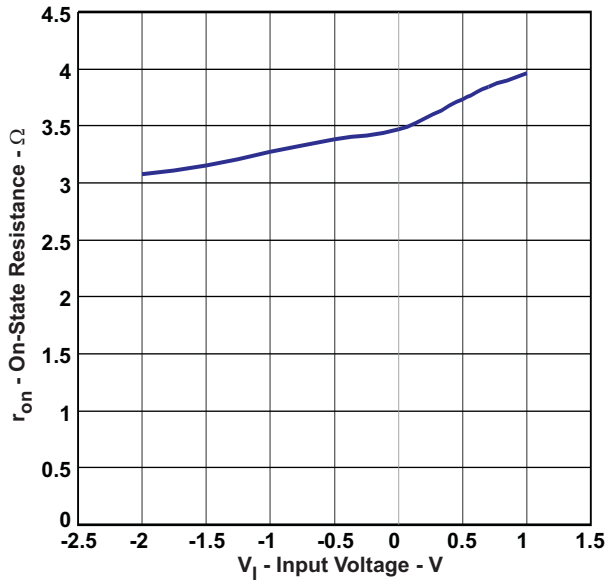


Figure 1. ON Resistance vs V<sub>1</sub> for Audio Switch

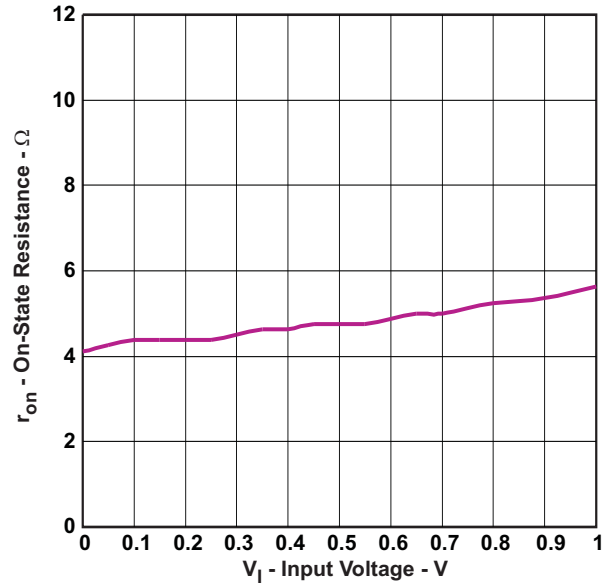


Figure 2. ON Resistance vs V<sub>1</sub> for USB Switch

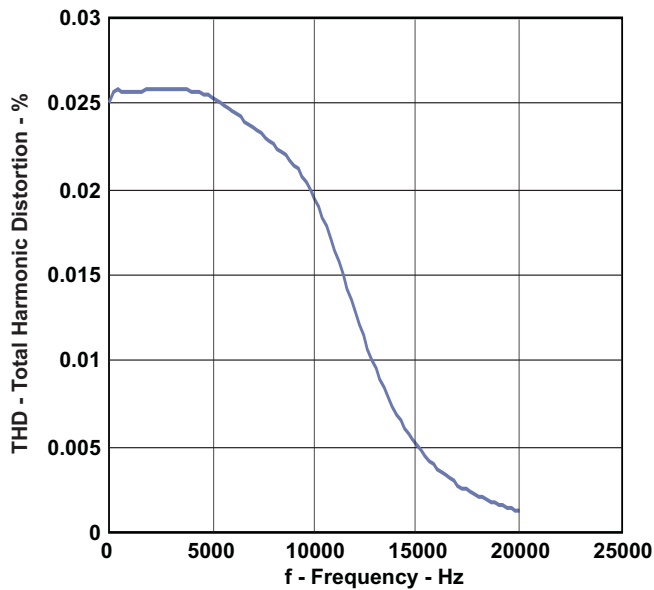


Figure 3. THD vs Frequency for Audio Switch

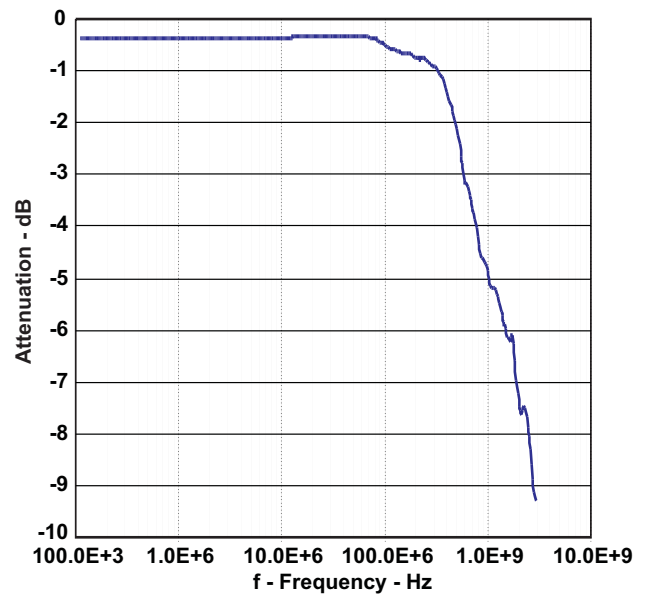


Figure 4. Gain vs Frequency for USB Switch

TYPICAL CHARACTERISTICS (continued)

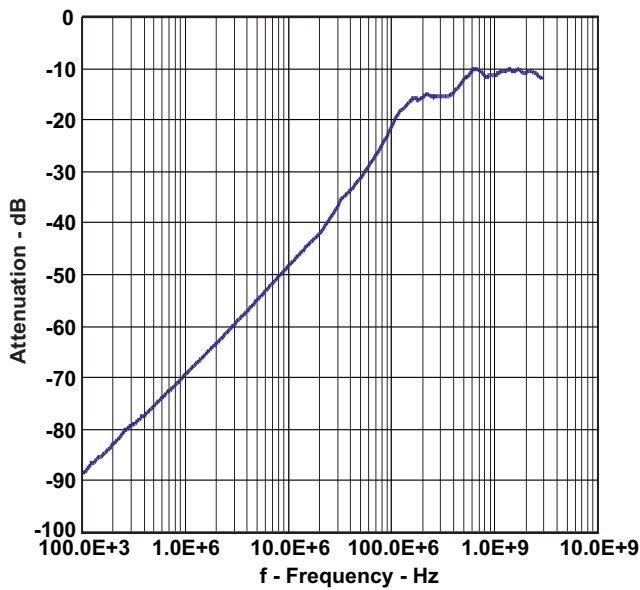


Figure 5. Off Isolation vs Frequency for Audio Switch

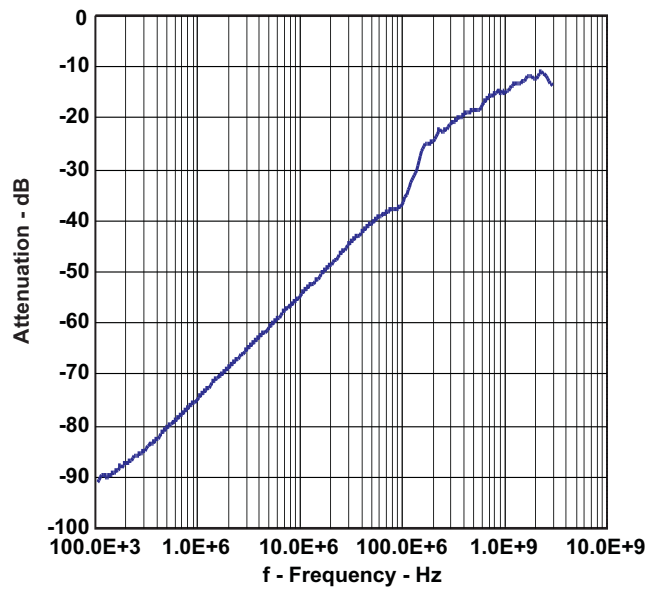


Figure 6. Off Isolation vs Frequency for USB Switch

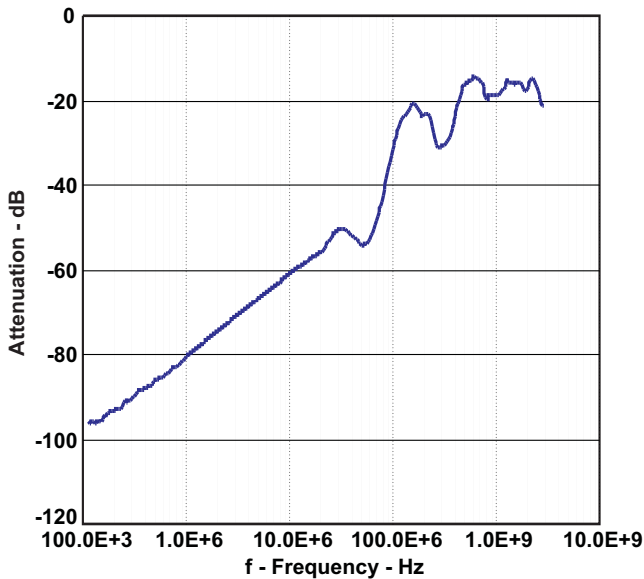


Figure 7. Cross Talk vs Frequency for Audio Switch

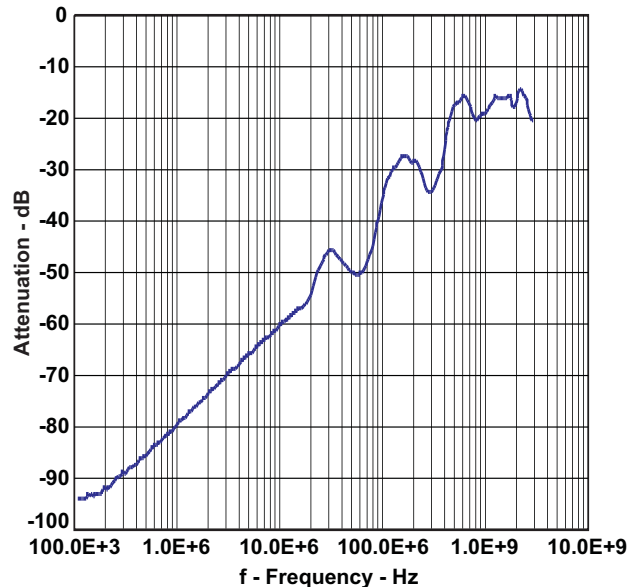
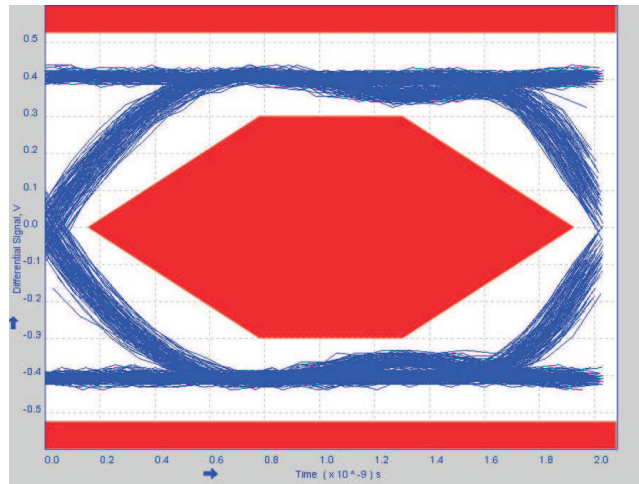


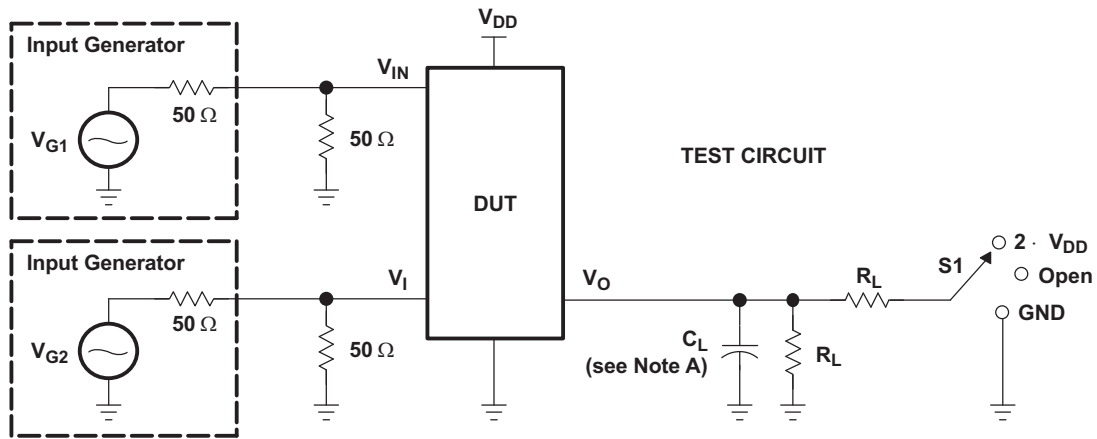
Figure 8. Cross Talk vs Frequency for USB Switch

**TYPICAL CHARACTERISTICS (continued)**

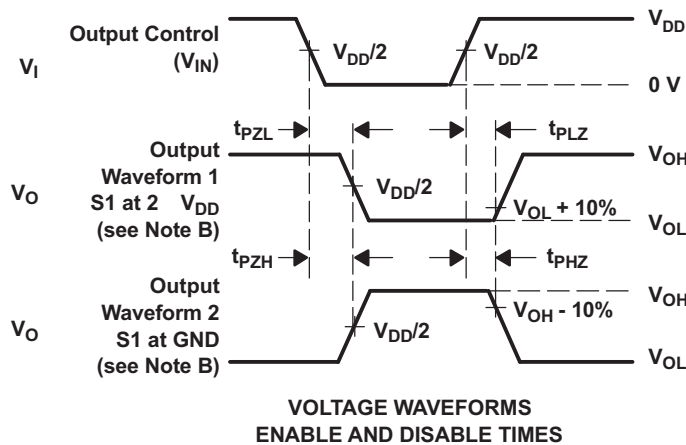


**Figure 9. USB 2.0 Eye Pattern for USB Switch**

**PARAMETER MEASUREMENT INFORMATION  
(Enable and Disable Times)**



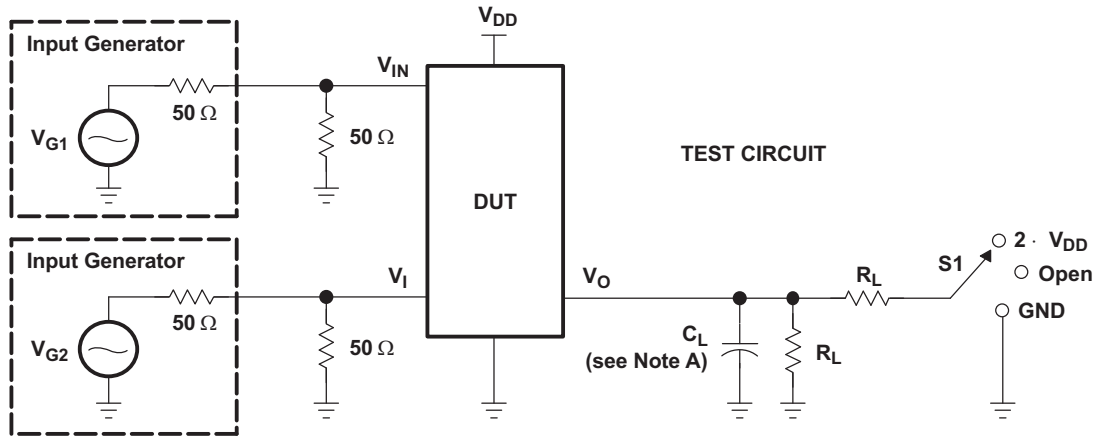
TEST	V <sub>AUDIO</sub> (V <sub>DD</sub> )	S1	R <sub>L</sub>	V <sub>in</sub>	C <sub>L</sub>	V <sub>Δ</sub>
t <sub>PLZ</sub> /t <sub>PZL</sub>	3.3 V	2 · V <sub>DD</sub>	200 Ω	GND	10 pF	0.3 V
t <sub>PHZ</sub> /t <sub>PZH</sub>	3.3 V	GND	200 Ω	V <sub>DD</sub>	10 pF	0.3 V



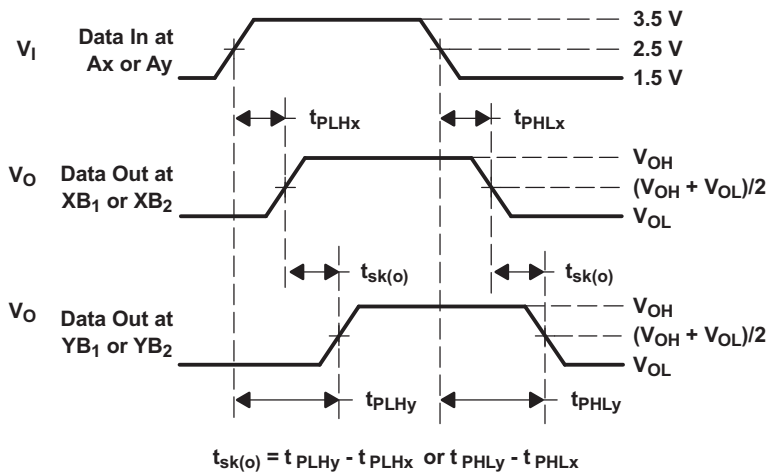
- NOTES: A. C<sub>L</sub> includes probe and jig capacitance.  
 B. Waveform 1 is for an output with internal conditions such that the output is low except when disabled by the output control. Waveform 2 is for an output with internal conditions such that the output is high, except when disabled by the output control.  
 C. All input pulses are supplied by generators having the following characteristics: PRR ≤ 10 MHz, Z<sub>O</sub> = 50 Ω, t<sub>r</sub> ≤ 2.5 ns, t<sub>f</sub> ≤ 2.5 ns.  
 D. The outputs are measured one at a time, with one transition per measurement.  
 E. t<sub>PLZ</sub> and t<sub>PHZ</sub> are the same as t<sub>dis</sub> or t<sub>OFF</sub>.  
 F. t<sub>PZL</sub> and t<sub>PZH</sub> are the same as t<sub>en</sub> or t<sub>ON</sub>.

**Figure 10. Test Circuit and Voltage Waveforms**

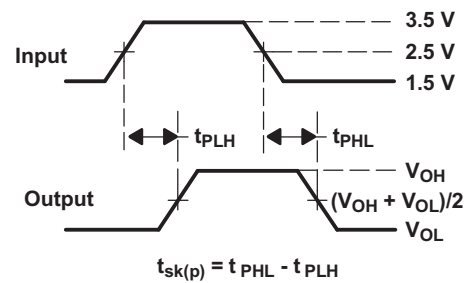
### PARAMETER MEASUREMENT INFORMATION (Skew)



TEST	V <sub>AUDIO</sub> (V <sub>DD</sub> )	S1	R <sub>L</sub>	V <sub>in</sub>	C <sub>L</sub>
t <sub>sk(o)</sub>	3.3 V ± 0.3 V	Open	200 Ω	V <sub>DD</sub> or GND	10 pF
t <sub>sk(p)</sub>	3.3 V ± 0.3 V	Open	200 Ω	V <sub>DD</sub> or GND	10 pF



**VOLTAGE WAVEFORMS  
OUTPUT SKEW (t<sub>sk(o)</sub>)**

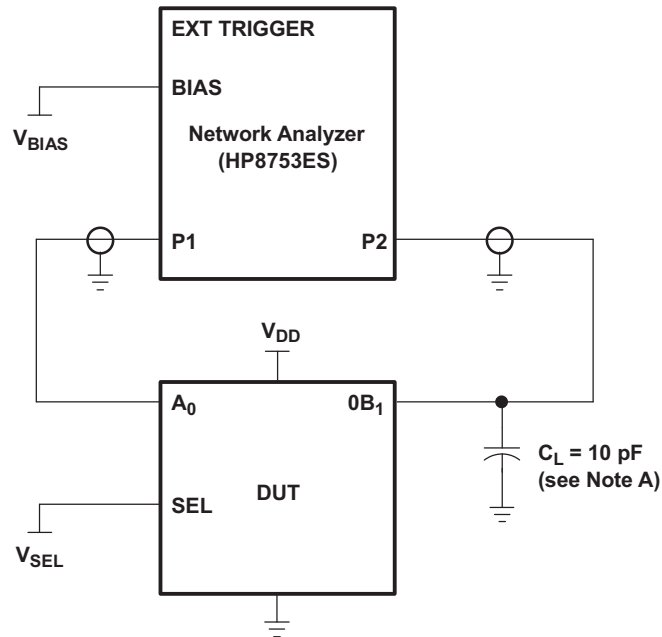


**VOLTAGE WAVEFORMS  
PULSE SKEW [t<sub>sk(p)</sub>]**

- NOTES: A. C<sub>L</sub> includes probe and jig capacitance.  
 B. Waveform 1 is for an output with internal conditions such that the output is low except when disabled by the output control. Waveform 2 is for an output with internal conditions such that the output is high, except when disabled by the output control.  
 C. All input pulses are supplied by generators having the following characteristics: PRR ≤ 10 MHz, Z<sub>O</sub> = 50 Ω, t<sub>r</sub> ≤ 2.5 ns, t<sub>f</sub> ≤ 2.5 ns.  
 D. The outputs are measured one at a time, with one transition per measurement.

**Figure 11. Test Circuit and Voltage Waveforms**

PARAMETER MEASUREMENT INFORMATION



A.  $C_L$  includes probe and jig capacitance.

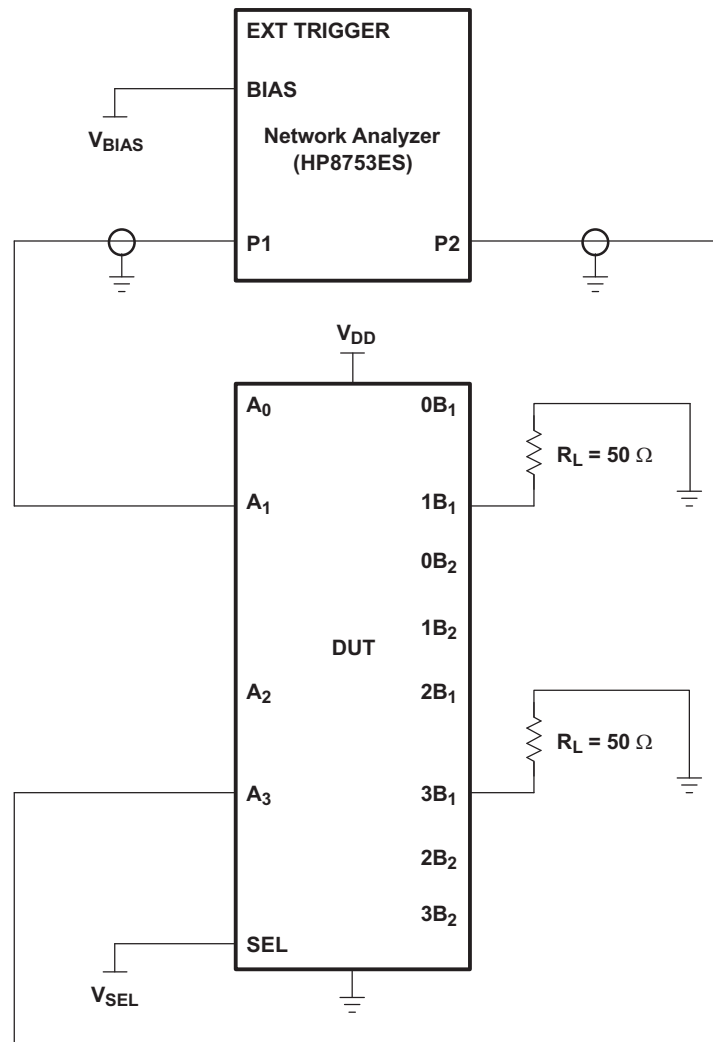
Figure 12. Test Circuit for Frequency Response (BW)

Frequency response is measured at the output of the ON channel. For example, when  $V_{SEL} = 0$  and  $A_0$  is the input, the output is measured at  $0B_1$ . All unused analog I/O ports are left open.

HP8753ES Setup

Average = 4  
 RBW = 3 kHz  
 $V_{BIAS} = 0.35$  V  
 ST = 2 s  
 P1 = 0 dBm

## PARAMETER MEASUREMENT INFORMATION (continued)



- A.  $C_L$  includes probe and jig capacitance.
- B. A 50- $\Omega$  termination resistor is needed to match the loading of the network analyzer.

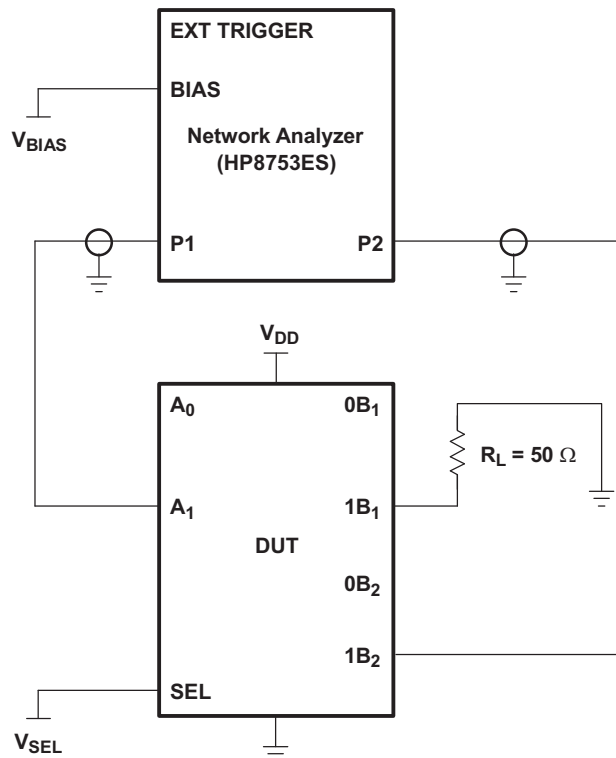
**Figure 13. Test Circuit for Crosstalk ( $X_{TALK}$ )**

Crosstalk is measured at the output of the nonadjacent ON channel. For example, when  $V_{SEL} = 0$  and  $A_1$  is the input, the output is measured at  $A_3$ . All unused analog input (A) ports are connected to GND, and output (B) ports are left open.

### HP8753ES Setup

Average = 4  
 RBW = 3 kHz  
 $V_{BIAS} = 0.35$  V  
 ST = 2 s  
 P1 = 0 dBm

PARAMETER MEASUREMENT INFORMATION (continued)



- A.  $C_L$  includes probe and jig capacitance.
- B. A 50- $\Omega$  termination resistor is needed to match the loading of the network analyzer.

**Figure 14. Test Circuit for OFF Isolation ( $O_{ISO}$ )**

OFF isolation is measured at the output of the OFF channel. For example, when  $V_{SEL} = GND$  and  $A_1$  is the input, the output is measured at  $1B_2$ . All unused analog input (A) ports are connected to ground, and output (B) ports are left open.

**HP8753ES Setup**

Average = 4  
 RBW = 3 kHz  
 $V_{BIAS} = 0.35 V$   
 ST = 2 s  
 P1 = 0 dBm

**PACKAGING INFORMATION**

Orderable Device	Status (1)	Package Type	Package Drawing	Pins	Package Qty	Eco Plan (2)	Lead finish/ Ball material (6)	MSL Peak Temp (3)	Op Temp (°C)	Device Marking (4/5)	Samples
TS5USBA224RSWR	ACTIVE	UQFN	RSW	10	3000	RoHS & Green	NIPDAU   NIPDAUAG	Level-1-260C-UNLIM	-40 to 85	(A5R, A5V)	Samples

(1) The marketing status values are defined as follows:

**ACTIVE:** Product device recommended for new designs.

**LIFEBUY:** TI has announced that the device will be discontinued, and a lifetime-buy period is in effect.

**NRND:** Not recommended for new designs. Device is in production to support existing customers, but TI does not recommend using this part in a new design.

**PREVIEW:** Device has been announced but is not in production. Samples may or may not be available.

**OBSELETE:** TI has discontinued the production of the device.

(2) **RoHS:** TI defines "RoHS" to mean semiconductor products that are compliant with the current EU RoHS requirements for all 10 RoHS substances, including the requirement that RoHS substance do not exceed 0.1% by weight in homogeneous materials. Where designed to be soldered at high temperatures, "RoHS" products are suitable for use in specified lead-free processes. TI may reference these types of products as "Pb-Free".

**RoHS Exempt:** TI defines "RoHS Exempt" to mean products that contain lead but are compliant with EU RoHS pursuant to a specific EU RoHS exemption.

**Green:** TI defines "Green" to mean the content of Chlorine (Cl) and Bromine (Br) based flame retardants meet JS709B low halogen requirements of <=1000ppm threshold. Antimony trioxide based flame retardants must also meet the <=1000ppm threshold requirement.

(3) MSL, Peak Temp. - The Moisture Sensitivity Level rating according to the JEDEC industry standard classifications, and peak solder temperature.

(4) There may be additional marking, which relates to the logo, the lot trace code information, or the environmental category on the device.

(5) Multiple Device Markings will be inside parentheses. Only one Device Marking contained in parentheses and separated by a "-" will appear on a device. If a line is indented then it is a continuation of the previous line and the two combined represent the entire Device Marking for that device.

(6) Lead finish/Ball material - Orderable Devices may have multiple material finish options. Finish options are separated by a vertical ruled line. Lead finish/Ball material values may wrap to two lines if the finish value exceeds the maximum column width.

**Important Information and Disclaimer:**The information provided on this page represents TI's knowledge and belief as of the date that it is provided. TI bases its knowledge and belief on information provided by third parties, and makes no representation or warranty as to the accuracy of such information. Efforts are underway to better integrate information from third parties. TI has taken and continues to take reasonable steps to provide representative and accurate information but may not have conducted destructive testing or chemical analysis on incoming materials and chemicals. TI and TI suppliers consider certain information to be proprietary, and thus CAS numbers and other limited information may not be available for release.

In no event shall TI's liability arising out of such information exceed the total purchase price of the TI part(s) at issue in this document sold by TI to Customer on an annual basis.

**TAPE AND REEL INFORMATION**

**QUADRANT ASSIGNMENTS FOR PIN 1 ORIENTATION IN TAPE**

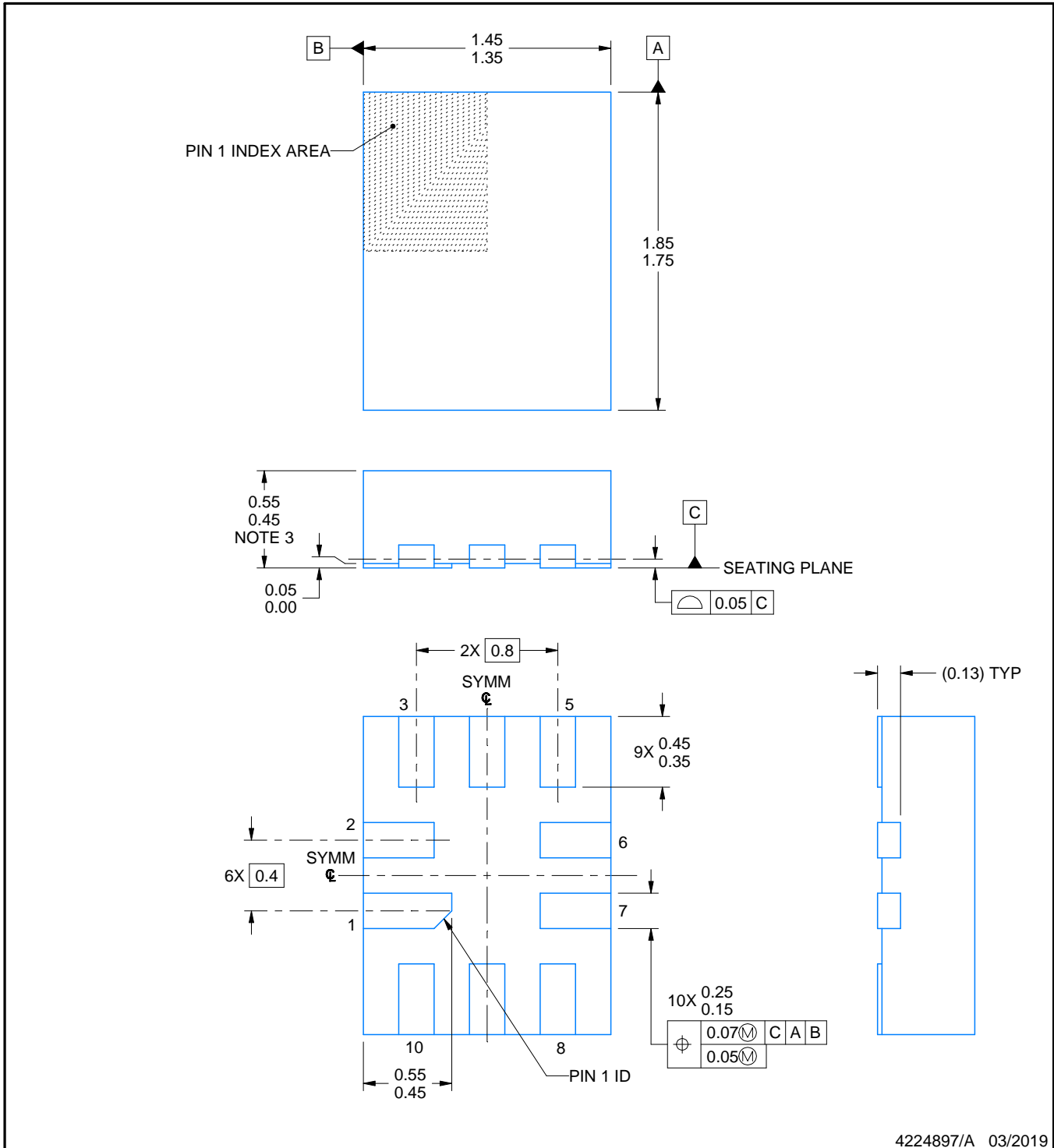
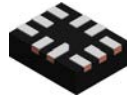

\*All dimensions are nominal

Device	Package Type	Package Drawing	Pins	SPQ	Reel Diameter (mm)	Reel Width W1 (mm)	A0 (mm)	B0 (mm)	K0 (mm)	P1 (mm)	W (mm)	Pin1 Quadrant
TS5USBA224RSWR	UQFN	RSW	10	3000	180.0	8.4	1.59	2.09	0.72	4.0	8.0	Q1
TS5USBA224RSWR	UQFN	RSW	10	3000	180.0	9.5	1.6	2.0	0.8	4.0	8.0	Q1

**TAPE AND REEL BOX DIMENSIONS**


\*All dimensions are nominal

Device	Package Type	Package Drawing	Pins	SPQ	Length (mm)	Width (mm)	Height (mm)
TS5USBA224RSWR	UQFN	RSW	10	3000	202.0	201.0	28.0
TS5USBA224RSWR	UQFN	RSW	10	3000	189.0	185.0	36.0



4224897/A 03/2019

NOTES:

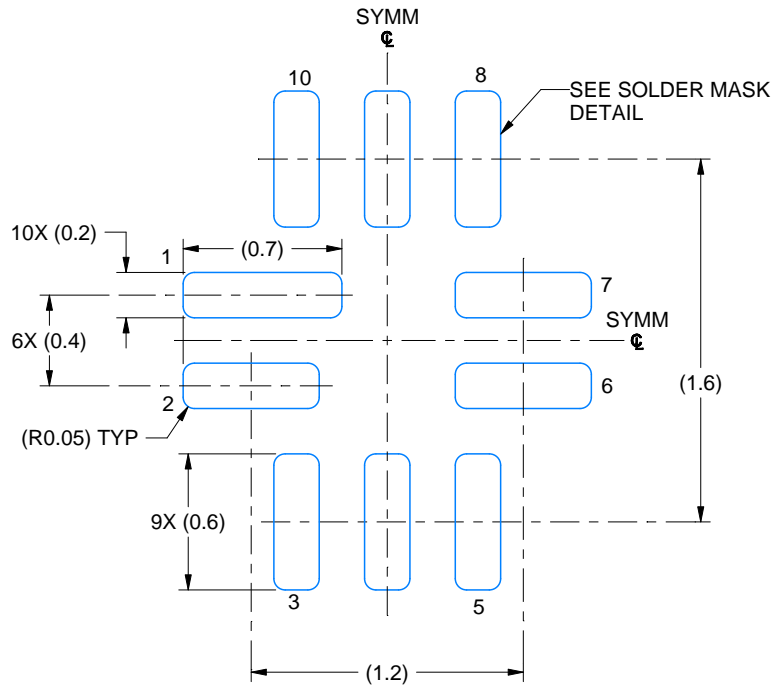
1. All linear dimensions are in millimeters. Any dimensions in parenthesis are for reference only. Dimensioning and tolerancing per ASME Y14.5M.
2. This drawing is subject to change without notice.
3. This package complies to JEDEC MO-288 variation UDEE, except minimum package height.

# EXAMPLE BOARD LAYOUT

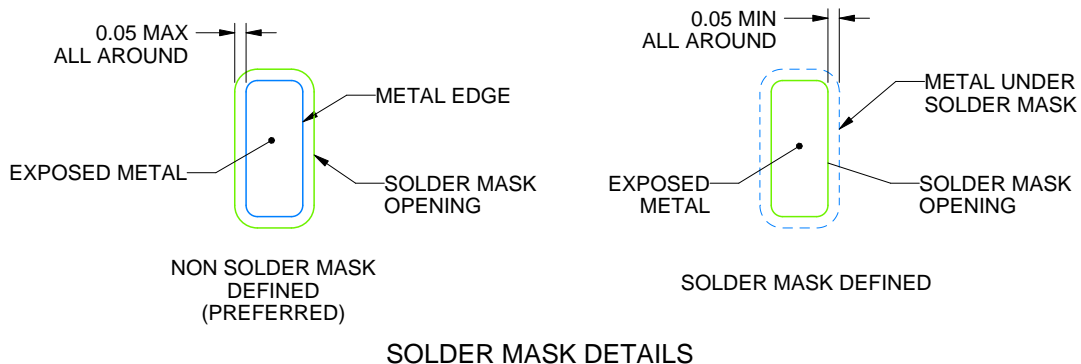
RSW0010A

UQFN - 0.55 mm max height

PLASTIC QUAD FLATPACK - NO LEAD



LAND PATTERN EXAMPLE  
EXPOSED METAL SHOWN  
SCALE: 30X



SOLDER MASK DETAILS

4224897/A 03/2019

NOTES: (continued)

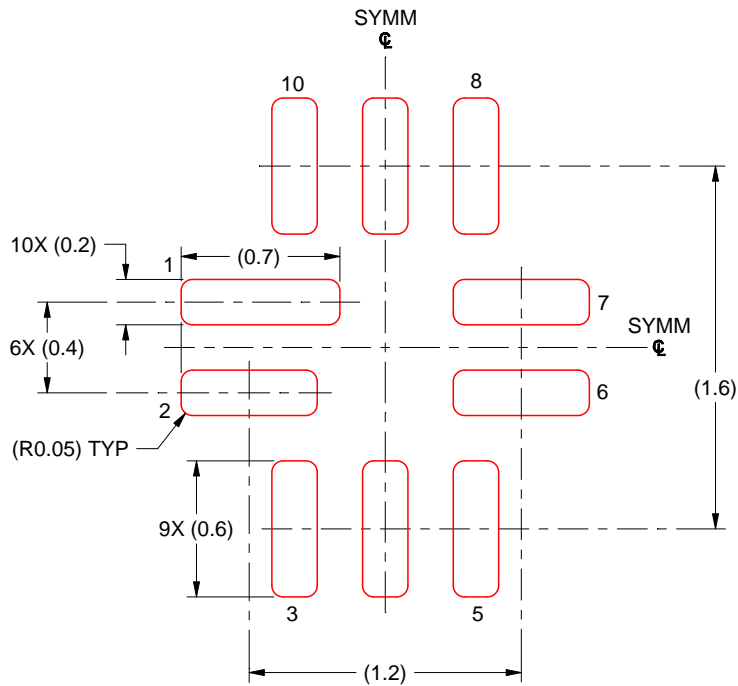
4. This package is designed to be soldered to a thermal pad on the board. For more information, see Texas Instruments literature number SLUA271 ([www.ti.com/lit/sluea271](http://www.ti.com/lit/sluea271)).
5. Vias are optional depending on application, refer to device data sheet. If any vias are implemented, refer to their locations shown on this view. It is recommended that vias under paste be filled, plugged or tented.

# EXAMPLE STENCIL DESIGN

RSW0010A

UQFN - 0.55 mm max height

PLASTIC QUAD FLATPACK - NO LEAD



SOLDER PASTE EXAMPLE  
BASED ON 0.125 MM THICK STENCIL  
SCALE: 30X

4224897/A 03/2019

NOTES: (continued)

6. Laser cutting apertures with trapezoidal walls and rounded corners may offer better paste release. IPC-7525 may have alternate design recommendations.

## IMPORTANT NOTICE AND DISCLAIMER

TI PROVIDES TECHNICAL AND RELIABILITY DATA (INCLUDING DATA SHEETS), DESIGN RESOURCES (INCLUDING REFERENCE DESIGNS), APPLICATION OR OTHER DESIGN ADVICE, WEB TOOLS, SAFETY INFORMATION, AND OTHER RESOURCES "AS IS" AND WITH ALL FAULTS, AND DISCLAIMS ALL WARRANTIES, EXPRESS AND IMPLIED, INCLUDING WITHOUT LIMITATION ANY IMPLIED WARRANTIES OF MERCHANTABILITY, FITNESS FOR A PARTICULAR PURPOSE OR NON-INFRINGEMENT OF THIRD PARTY INTELLECTUAL PROPERTY RIGHTS.

These resources are intended for skilled developers designing with TI products. You are solely responsible for (1) selecting the appropriate TI products for your application, (2) designing, validating and testing your application, and (3) ensuring your application meets applicable standards, and any other safety, security, regulatory or other requirements.

These resources are subject to change without notice. TI grants you permission to use these resources only for development of an application that uses the TI products described in the resource. Other reproduction and display of these resources is prohibited. No license is granted to any other TI intellectual property right or to any third party intellectual property right. TI disclaims responsibility for, and you will fully indemnify TI and its representatives against, any claims, damages, costs, losses, and liabilities arising out of your use of these resources.

TI's products are provided subject to [TI's Terms of Sale](#) or other applicable terms available either on [ti.com](https://www.ti.com) or provided in conjunction with such TI products. TI's provision of these resources does not expand or otherwise alter TI's applicable warranties or warranty disclaimers for TI products.

TI objects to and rejects any additional or different terms you may have proposed.

Mailing Address: Texas Instruments, Post Office Box 655303, Dallas, Texas 75265  
Copyright © 2023, Texas Instruments Incorporated

## Looking for pricing, stock, or lifecycle information?

Click below to explore more details on WIN SOURCE:

 [View TS5USBA224RSWR on WIN SOURCE](#)

 [Texas Instruments](#) Information

## Optimize Your Supply Chain with WIN SOURCE Solutions

-  Global Sourcing Solution
-  Obsolete Management
-  Cost Control Management
-  Shortage Management
-  Alternative Solution
-  Excess Inventory Management