



**THE DATASHEET OF
TS5A4624DCKR**



FEATURES

- Isolation in Power-Down Mode, $V_+ = 0$
- Specified Break-Before-Make Switching
- Low ON-State Resistance ($1\ \Omega$)
- Control Inputs Are 5.5-V Tolerant
- Low Charge Injection
- Excellent ON-State Resistance Matching
- Low Total Harmonic Distortion (THD)
- 1.65-V to 5.5-V Single-Supply Operation
- Latch-Up Performance Exceeds 100 mA Per JESD 78, Class II
- ESD Performance Tested Per JESD
 - 2000-V Human-Body Model (A114-B, Class II)
 - 1000-V Charged-Device Model (C101)

APPLICATIONS

- Cell Phones
- PDAs
- Portable Instrumentation
- Audio and Video Signal Routing
- Low-Voltage Data-Acquisition Systems
- Communication Circuits
- Modems
- Hard Drives
- Computer Peripherals
- Wireless Terminals and Peripherals

DESCRIPTION

The TS5A4624 is a single-pole double-throw (SPDT) analog switch that is designed to operate from 1.65 V to 5.5 V. The device offers low ON-state resistance and excellent ON-state resistance matching with the break-before-make feature, to prevent signal distortion during the transferring of a signal from one channel to another. The device has an excellent total harmonic distortion (THD) performance and consumes very low power. These features make this device suitable for portable audio applications.

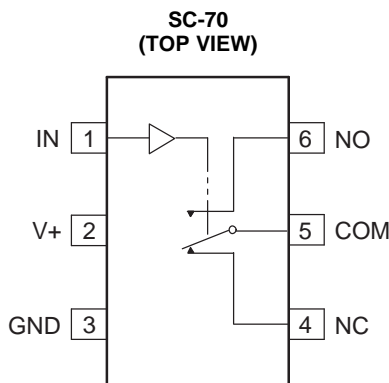

Switches are shown for logic 0 input.

FUNCTION TABLE

IN	NC TO COM, COM TO NC	NO TO COM, COM TO NO
L	ON	OFF
H	OFF	ON



Please be aware that an important notice concerning availability, standard warranty, and use in critical applications of Texas Instruments semiconductor products and disclaimers thereto appears at the end of this data sheet.

TS5A4624
1-Ω SPDT ANALOG SWITCH
5-V/3.3-V SINGLE-CHANNEL 2:1 MULTIPLEXER/DEMULTIPLEXER

SLYS014A–DECEMBER 2005–REVISED AUGUST 2006

SUMMARY OF CHARACTERISTICS⁽¹⁾

Configuration	2:1 Multiplexer/ Demultiplexer (1 × SPDT)
Number of channels	1
ON-state resistance r_{on}	1.1 Ω
ON-state resistance match (Δr_{on})	0.1 Ω
ON-state resistance flatness $r_{on(flat)}$	0.15 Ω
Turn-on/turn-off time ($t_{ON/tOFF}$)	20 ns/15 ns
Break-before-make time (t_{BBM})	12 ns
Charge injection (Q_C)	-20 pC
Bandwidth (BW)	100 MHz
OFF isolation (O_{ISO})	-65 dB at 1 MHz
Crosstalk (X_{TALK})	-66 dB at 1 MHz
Total harmonic distortion (THD)	0.01%
Leakage current ($I_{NO(OFF)}/I_{NC(OFF)}$)	±20 nA
Power-supply current (I_+)	0.1 μA
Package options	6-pin DCK

(1) $V_+ = 5\text{ V}$, $T_A = 25^\circ\text{C}$

ORDERING INFORMATION

T_A	PACKAGE ⁽¹⁾		ORDERABLE PART NUMBER	TOP-SIDE MARKING ⁽²⁾
-40°C to 85°C	SOT (SC-70) – DCK	Tape and reel	TS5A4624DCKR	JW_

- (1) Package drawings, standard packing quantities, thermal data, symbolization, and PCB design guidelines are available at www.ti.com/sc/package.
(2) DCK: The actual top-side marking has one additional character that designates the assembly/test site.

Absolute Minimum and Maximum Ratings⁽¹⁾⁽²⁾

over operating free-air temperature range (unless otherwise noted)

		MIN	MAX	UNIT
V ₊	Supply voltage range ⁽³⁾	-0.5	6.5	V
V _{NO} V _{NC} V _{COM}	Analog voltage range ⁽³⁾⁽⁴⁾⁽⁵⁾	-0.5	V ₊ + 0.5	V
I _K	Analog port diode current	V _{NC} , V _{NO} , V _{COM} < 0		mA
I _{NO} I _{NC} I _{COM}	On-state switch current	-200	200	mA
	On-state peak switch current ⁽⁶⁾	-400	400	
V _I	Digital input voltage range ⁽³⁾⁽⁴⁾	-0.5	6.5	V
I _{IK}	Digital input clamp current	V _I < 0		mA
I ₊	Continuous current through V ₊		100	mA
I _{GND}	Continuous current through GND	-100	100	mA
θ _{JA}	Package thermal impedance ⁽⁷⁾		259	°C/W
T _{stg}	Storage temperature range	-65	150	°C

- (1) Stresses beyond those listed under "absolute maximum ratings" may cause permanent damage to the device. These are stress ratings only, and functional operation of the device at these or any other conditions beyond those indicated under "recommended operating conditions" is not implied. Exposure to absolute-maximum-rated conditions for extended periods may affect device reliability.
- (2) The algebraic convention, whereby the most negative value is a minimum and the most positive value is a maximum
- (3) All voltages are with respect to ground, unless otherwise specified.
- (4) The input and output voltage ratings may be exceeded if the input and output clamp-current ratings are observed.
- (5) This value is limited to 5.5 V maximum.
- (6) Pulse at 1-ms duration < 10% duty cycle
- (7) The package thermal impedance is calculated in accordance with JESD 51-7.

TS5A4624
1-Ω SPDT ANALOG SWITCH
5-V/3.3-V SINGLE-CHANNEL 2:1 MULTIPLEXER/DEMULTIPLEXER

SLYS014A–DECEMBER 2005–REVISED AUGUST 2006

Electrical Characteristics for 5-V Supply⁽¹⁾

$V_+ = 4.5\text{ V to }5.5\text{ V}$, $T_A = -40^\circ\text{C to }85^\circ\text{C}$ (unless otherwise noted)

PARAMETER	SYMBOL	TEST CONDITIONS	T_A	V_+	MIN	TYP	MAX	UNIT	
Analog Switch									
Analog signal range	V_{COM}, V_{NO}, V_{NC}				0		V_+	V	
Peak ON resistance	r_{peak}	$0 \leq (V_{NO} \text{ or } V_{NC}) \leq V_+$, $I_{COM} = -100\text{ mA}$,	Switch ON, See Figure 13	25°C	4.5 V	0.8	1.1	Ω	
				Full			1.5		
ON-state resistance	r_{on}	$V_{NO} \text{ or } V_{NC} = 2.5\text{ V}$, $I_{COM} = -100\text{ mA}$,	Switch ON, See Figure 13	25°C	4.5 V	0.7	0.9	Ω	
				Full			1.1		
ON-state resistance match between channels	Δr_{on}	$V_{NO} \text{ or } V_{NC} = 2.5\text{ V}$, $I_{COM} = -100\text{ mA}$,	Switch ON, See Figure 13	25°C	4.5 V	0.05	0.1	Ω	
				Full			0.1		
ON-state resistance flatness	$r_{on(flat)}$	$0 \leq (V_{NO} \text{ or } V_{NC}) \leq V_+$, $I_{COM} = -100\text{ mA}$,	Switch ON, See Figure 13	25°C	4.5 V	0.15		Ω	
				25°C		0.1	0.25		
				Full		0.25			
NC, NO OFF leakage current	$I_{NC(OFF)}, I_{NO(OFF)}$	$V_{NC} \text{ or } V_{NO} = 1\text{ V}$, $V_{COM} = 1\text{ V to }4.5\text{ V}$, or $V_{NC} \text{ or } V_{NO} = 4.5\text{ V}$, $V_{COM} = 1\text{ V to }4.5\text{ V}$,	Switch OFF, See Figure 14	25°C	5.5 V	-20	2	20	nA
				Full		-100	100		
	$I_{NC(PWROFF)}, I_{NO(PWROFF)}$	$V_{NC} \text{ or } V_{NO} = 0 \text{ to } 5.5\text{ V}$, $V_{COM} = 5.5\text{ V to } 0$,	Switch OFF, See Figure 14	25°C	0 V	-1	0.2	1	μA
				Full		-20	20		
NC, NO ON leakage current	$I_{NC(ON)}, I_{NO(ON)}$	$V_{NC} \text{ or } V_{NO} = 1\text{ V}$, $V_{COM} = \text{Open}$, or $V_{NC} \text{ or } V_{NO} = 4.5\text{ V}$, $V_{COM} = \text{Open}$,	Switch ON, See Figure 15	25°C	5.5 V	-20	2	20	nA
				Full		-100	100		
COM OFF leakage current	$I_{COM(PWROFF)}$	$V_{NC} \text{ or } V_{NO} = 0 \text{ to } 5.5\text{ V}$, $V_{COM} = 5.5\text{ V to } 0$,	Switch OFF, See Figure 14	25°	0 V	-1	0.1	1	μA
				Full		-20	20		
COM ON leakage current	$I_{COM(ON)}$	$V_{NC} \text{ or } V_{NO} = \text{Open}$, $V_{COM} = 1\text{ V}$, or $V_{NC} \text{ or } V_{NO} = \text{Open}$, $V_{COM} = 4.5\text{ V}$,	Switch ON, See Figure 15	25°C	5.5 V	-20	2	20	nA
				Full		-100	100		
Digital Input (IN)									
Input logic high	V_{IH}			Full		2.4	5.5	V	
Input logic low	V_{IL}			Full		0	0.8	V	
Input leakage current	I_{IH}, I_{IL}	$V_I = 5.5\text{ V or } 0$		25°C	5.5 V	-2	2	nA	
				Full		100	100		

(1) The algebraic convention, whereby the most negative value is a minimum and the most positive value is a maximum

Electrical Characteristics for 5-V Supply⁽¹⁾ (Continued)

$V_+ = 4.5\text{ V to }5.5\text{ V}$, $T_A = -40^\circ\text{C to }85^\circ\text{C}$ (unless otherwise noted)

PARAMETER	SYMBOL	TEST CONDITIONS	T_A	V_+	MIN	TYP	MAX	UNIT	
Dynamic									
Turn-on time	t_{ON}	$V_{COM} = V_+$, $R_L = 50\ \Omega$,	$C_L = 35\text{ pF}$, See Figure 17	25°C	5 V	4	12	22	ns
				Full	4.5 V to 5.5 V	2		25	
Turn-off time	t_{OFF}	$V_{COM} = V_+$, $R_L = 50\ \Omega$,	$C_L = 35\text{ pF}$, See Figure 17	25°C	5 V	1	5	8	ns
				Full	4.5 V to 5.5 V	1		10	
Break-before-make time	t_{BBM}	$V_{NC} = V_{NO} = V_+$, $R_L = 50\ \Omega$,	$C_L = 35\text{ pF}$, See Figure 18	25°C	5 V	1	8	13	ns
				Full	4.5 V to 5.5 V	1		15	
Charge injection	Q_C	$V_{GEN} = 0$, $R_{GEN} = 0$,	$C_L = 1\text{ nF}$, See Figure 22	25°C	5 V		15.5	pC	
NC, NO OFF capacitance	$C_{NC(OFF)}$, $C_{NO(OFF)}$	V_{NC} or $V_{NO} = V_+$ or GND, Switch OFF,	See Figure 16	25°C	5 V		18	pF	
NC, NO ON capacitance	$C_{NC(ON)}$, $C_{NO(ON)}$	V_{NC} or $V_{NO} = V_+$ or GND, Switch ON,	See Figure 16	25°C	5 V		55	pF	
COM ON capacitance	$C_{COM(ON)}$	$V_{COM} = V_+$ or GND, Switch ON,	See Figure 16	25°C	5 V		55	pF	
Digital input capacitance	C_I	$V_I = V_+$ or GND,	See Figure 16	25°C	5 V		2	pF	
Bandwidth	BW	$R_L = 50\ \Omega$, Switch ON,	See Figure 19	25°C	5 V		90	MHz	
OFF isolation	O_{ISO}	$R_L = 50\ \Omega$, $f = 1\text{ MHz}$,	Switch OFF, See Figure 20	25°C	5 V		-63	dB	
Crosstalk	X_{TALK}	$R_L = 50\ \Omega$, $f = 1\text{ MHz}$,	Switch ON, See Figure 21	25°C	5 V		-63	dB	
Total harmonic distortion	THD	$R_L = 600\ \Omega$, $C_L = 50\text{ pF}$,	$f = 200\text{ Hz to }20\text{ kHz}$, See Figure 23	25°C	5 V		0.004	%	
Supply									
Positive supply current	I_+	$V_I = V_+$ or GND,	Switch ON or OFF	25°C	5.5 V		10	50	nA
				Full				500	

(1) The algebraic convention, whereby the most negative value is a minimum and the most positive value is a maximum

TS5A4624
1-Ω SPDT ANALOG SWITCH
5-V/3.3-V SINGLE-CHANNEL 2:1 MULTIPLEXER/DEMULTIPLEXER

SLYS014A–DECEMBER 2005–REVISED AUGUST 2006

Electrical Characteristics for 3.3-V Supply⁽¹⁾

$V_+ = 3\text{ V to }3.6\text{ V}$, $T_A = -40^\circ\text{C to }85^\circ\text{C}$ (unless otherwise noted)

PARAMETER	SYMBOL	TEST CONDITIONS	T_A	V_+	MIN	TYP	MAX	UNIT	
Analog Switch									
Analog signal range	V_{COM}, V_{NO}, V_{NC}				0		V_+	V	
Peak ON resistance	r_{peak}	$0 \leq (V_{NO} \text{ or } V_{NC}) \leq V_+$, $I_{COM} = -100\text{ mA}$,	Switch ON, See Figure 13	25°C	3 V	1.3	1.6	Ω	
				Full			2		
ON-state resistance	r_{on}	$V_{NO} \text{ or } V_{NC} = 2\text{ V}$, $I_{COM} = -100\text{ mA}$,	Switch ON, See Figure 13	25°C	3 V	1.2	1.5	Ω	
				Full			1.7		
ON-state resistance match between channels	Δr_{on}	$V_{NO} \text{ or } V_{NC} = 2\text{ V}, 0.8\text{ V}$, $I_{COM} = -100\text{ mA}$,	Switch ON, See Figure 13	25°C	3 V	0.1	0.15	Ω	
				Full			0.15		
ON-state resistance flatness	$r_{on(flat)}$	$0 \leq (V_{NO} \text{ or } V_{NC}) \leq V_+$, $I_{COM} = -100\text{ mA}$,	Switch ON, See Figure 13	25°C	3 V	0.2		Ω	
				25°C			0.15		0.3
				Full					0.3
NC, NO OFF leakage current	$I_{NC(OFF)}, I_{NO(OFF)}$	$V_{NC} \text{ or } V_{NO} = 1\text{ V}, V_{COM} = 1\text{ V to }3\text{ V}$, or $V_{NC} \text{ or } V_{NO} = 3\text{ V}, V_{COM} = 1\text{ V to }3\text{ V}$,	Switch OFF, See Figure 14	25°C	3.6 V	-20	2	20	nA
				Full		-50		50	
	$I_{NC(PWROFF)}, I_{NO(PWROFF)}$	$V_{NC} \text{ or } V_{NO} = 0 \text{ to } 3.6\text{ V}$, $V_{COM} = 3.6\text{ V to } 0$,	Switch OFF, See Figure 14	25°C	0 V	-1	0.2	1	μA
				Full		-15		15	
NC, NO ON leakage current	$I_{NC(ON)}, I_{NO(ON)}$	$V_{NC} \text{ or } V_{NO} = 1\text{ V}, V_{COM} = \text{Open}$, or $V_{NC} \text{ or } V_{NO} = 3\text{ V}, V_{COM} = \text{Open}$,	Switch ON, See Figure 15	25°C	3.6 V	-10	2	10	nA
				Full		-20		20	
COM OFF leakage current	$I_{COM(PWROFF)}$	$V_{NC} \text{ or } V_{NO} = 3.6\text{ V to } 0$, $V_{COM} = 0 \text{ to } 3.6\text{ V}$,	Switch OFF, See Figure 14	25°	0 V	-1	0.2	1	μA
				Full		-15		15	
COM ON leakage current	$I_{COM(ON)}$	$V_{NC} \text{ or } V_{NO} = \text{Open}, V_{COM} = 1\text{ V}$, or $V_{NC} \text{ or } V_{NO} = \text{Open}, V_{COM} = 3\text{ V}$,	Switch ON, See Figure 15	25°C	3.6 V	-10	2	10	nA
				Full		-20		20	
Digital Input (IN)									
Input logic high	V_{IH}		Full		2.4		5.5	V	
Input logic low	V_{IL}		Full		0		0.8	V	
Input leakage current	I_{IH}, I_{IL}	$V_I = 5.5\text{ V or } 0$	25°C	3.6 V	-2		2	nA	
			Full		-100		100		

(1) The algebraic convention, whereby the most negative value is a minimum and the most positive value is a maximum

Electrical Characteristics for 3.3-V Supply⁽¹⁾ (Continued)

$V_+ = 3\text{ V to }3.6\text{ V}$, $T_A = -40^\circ\text{C to }85^\circ\text{C}$ (unless otherwise noted)

PARAMETER	SYMBOL	TEST CONDITIONS	T_A	V_+	MIN	TYP	MAX	UNIT	
Dynamic									
Turn-on time	t_{ON}	$V_{COM} = V_+$, $R_L = 50\ \Omega$,	$C_L = 35\text{ pF}$, See Figure 17	25°C	3.3 V	4	16	25	ns
				Full	3 V to 3.6 V	2		27	
Turn-off time	t_{OFF}	$V_{COM} = V_+$, $R_L = 50\ \Omega$,	$C_L = 35\text{ pF}$, See Figure 17	25°C	3.3 V	1	5.5	8	ns
				Full	3 V to 3.6 V	1		11	
Break-before-make time	t_{BBM}	$V_{NC} = V_{NO} = V_+$, $R_L = 50\ \Omega$,	$C_L = 35\text{ pF}$, See Figure 18	25°C	3.3 V	2	12	20	ns
				Full	3 V to 3.6 V	2		25	
Charge injection	Q_C	$V_{GEN} = 0$, $R_{GEN} = 0$,	$C_L = 1\text{ nF}$, See Figure 22	25°C	3.3 V		9	pC	
NC, NO OFF capacitance	$C_{NC(OFF)}$, $C_{NO(OFF)}$	V_{NC} or $V_{NO} = V_+$ or GND, Switch OFF,	See Figure 16	25°C	3.3 V		18	pF	
NC, NO ON capacitance	$C_{NC(ON)}$, $C_{NO(ON)}$	V_{NC} or $V_{NO} = V_+$ or GND, Switch ON,	See Figure 16	25°C	3.3 V		55	pF	
COM ON capacitance	$C_{COM(ON)}$	$V_{COM} = V_+$ or GND, Switch ON,	See Figure 16	25°C	3.3 V		55	pF	
Digital input capacitance	C_I	$V_I = V_+$ or GND,	See Figure 16	25°C	3.3 V		2	pF	
Bandwidth	BW	$R_L = 50\ \Omega$, Switch ON,	See Figure 19	25°C	3.3 V		90	MHz	
OFF isolation	O_{ISO}	$R_L = 50\ \Omega$, $f = 1\text{ MHz}$,	Switch OFF, See Figure 20	25°C	3.3 V		-63	dB	
Crosstalk	X_{TALK}	$R_L = 50\ \Omega$, $f = 1\text{ MHz}$,	Switch ON, See Figure 21	25°C	3.3 V		-63	dB	
Total harmonic distortion	THD	$R_L = 600\ \Omega$, $C_L = 50\text{ pF}$,	$f = 20\text{ Hz to }20\text{ kHz}$, See Figure 23	25°C	3.3 V		0.01	%	
Supply									
Positive supply current	I_+	$V_I = V_+$ or GND,	Switch ON or OFF	25°C	3.6 V		10	50	nA
				Full				100	

(1) The algebraic convention, whereby the most negative value is a minimum and the most positive value is a maximum

TS5A4624
1-Ω SPDT ANALOG SWITCH
5-V/3.3-V SINGLE-CHANNEL 2:1 MULTIPLEXER/DEMULTIPLEXER

SLYS014A–DECEMBER 2005–REVISED AUGUST 2006

Electrical Characteristics for 2.5-V Supply⁽¹⁾

$V_+ = 2.3 \text{ V to } 2.7$, $T_A = -40^\circ\text{C to } 85^\circ\text{C}$ (unless otherwise noted)

PARAMETER	SYMBOL	TEST CONDITIONS	T_A	V_+	MIN	TYP	MAX	UNIT	
Analog Switch									
Analog signal range	V_{COM}, V_{NO}, V_{NC}				0		V_+	V	
Peak ON resistance	r_{peak}	$0 \leq (V_{NO} \text{ or } V_{NC}) \leq V_+$, $I_{COM} = -8 \text{ mA}$,	Switch ON, See Figure 13	25°C	2.3 V	1.8	2.5	Ω	
				Full			2.7		
ON-state resistance	r_{on}	$V_{NO} \text{ or } V_{NC} = 1.8 \text{ V}$, $I_{COM} = -8 \text{ mA}$,	Switch ON, See Figure 13	25°C	2.3 V	1.5	2	Ω	
				Full			2.4		
ON-state resistance match between channels	Δr_{on}	$V_{NO} \text{ or } V_{NC} = 1.8 \text{ V}$, $I_{COM} = -8 \text{ mA}$,	Switch ON, See Figure 13	25°C	2.3 V	0.15	0.2	Ω	
				Full			0.2		
ON-state resistance flatness	$r_{on(flat)}$	$0 \leq (V_{NO} \text{ or } V_{NC}) \leq V_+$, $I_{COM} = -8 \text{ mA}$,	Switch ON, See Figure 13	25°C	2.3 V	0.6		Ω	
				25°C			0.6		1
				Full			1		
NC, NO OFF leakage current	$I_{NC(OFF)}, I_{NO(OFF)}$	$V_{NC} \text{ or } V_{NO} = 0.5 \text{ V}$, $V_{COM} = 0.5 \text{ V to } 2.3 \text{ V}$, or $V_{NC} \text{ or } V_{NO} = 2.3 \text{ V}$, $V_{COM} = 0.5 \text{ V to } 2.3 \text{ V}$,	Switch OFF, See Figure 14	25°C	2.7 V	-20	2	20	nA
				Full		-50	50		
NC, NO ON leakage current	$I_{NC(ON)}, I_{NO(ON)}$	$V_{NC} \text{ or } V_{NO} = 0 \text{ to } 3.6 \text{ V}$, $V_{COM} = 3.6 \text{ V to } 0$,	Switch OFF, See Figure 14	25°C	0 V	-1	0.1	1	μA
				Full		-10	10		
NC, NO ON leakage current	$I_{NC(ON)}, I_{NO(ON)}$	$V_{NC} \text{ or } V_{NO} = 0.5 \text{ V}$, $V_{COM} = \text{Open}$, or $V_{NC} \text{ or } V_{NO} = 2.2 \text{ V}$, $V_{COM} = \text{Open}$,	Switch ON, See Figure 15	25°C	2.7 V	-10	2	10	nA
				Full		-20	20		
COM OFF leakage current	$I_{COM(PWROFF)}$	$V_{NC} \text{ or } V_{NO} = 2.7 \text{ V to } 0$, $V_{COM} = 0 \text{ to } 2.7 \text{ V}$,	Switch OFF, See Figure 14	25°	0 V	-1	0.1	10	μA
				Full		-10	10		
COM ON leakage current	$I_{COM(ON)}$	$V_{NC} \text{ or } V_{NO} = \text{Open}$, $V_{COM} = 0.5 \text{ V}$, or $V_{NC} \text{ or } V_{NO} = \text{Open}$, $V_{COM} = 2.2 \text{ V}$,	Switch ON, See Figure 15	25°C	2.7 V	-10	2	10	nA
				Full		-20	20		
Digital Input (IN)									
Input logic high	V_{IH}			Full		1.8	5.5	V	
Input logic low	V_{IL}			Full		0	0.6	V	
Input leakage current	I_{IH}, I_{IL}	$V_I = 5.5 \text{ V or } 0$		25°C	2.7 V	-2	2	nA	
				Full		20	20		

(1) The algebraic convention, whereby the most negative value is a minimum and the most positive value is a maximum

Electrical Characteristics for 2.5-V Supply⁽¹⁾ (Continued)

$V_+ = 2.3\text{ V to }2.7\text{ V}$, $T_A = -40^\circ\text{C to }85^\circ\text{C}$ (unless otherwise noted)

PARAMETER	SYMBOL	TEST CONDITIONS	T_A	V_+	MIN	TYP	MAX	UNIT	
Dynamic									
Turn-on time	t_{ON}	$V_{COM} = V_+$, $R_L = 50\ \Omega$,	$C_L = 35\text{ pF}$, See Figure 17	25°C	2.5 V	10	22	32	ns
				Full	2.3 V to 2.7 V	8		35	
Turn-off time	t_{OFF}	$V_{COM} = V_+$, $R_L = 50\ \Omega$,	$C_L = 35\text{ pF}$, See Figure 17	25°C	2.5 V	3	6	11	ns
				Full	2.3 V to 2.7 V	2		12	
Break-before-make time	t_{BBM}	$V_{NC} = V_{NO} = V_+$, $R_L = 50\ \Omega$,	$C_L = 35\text{ pF}$, See Figure 18	25°C	2.5 V	5	19	30	ns
				Full	2.3 V to 2.7 V	5		35	
Charge injection	Q_C	$V_{GEN} = 0$, $R_{GEN} = 0$,	$C_L = 1\text{ nF}$, See Figure 22	25°C	2.5 V		-7	pC	
NC, NO OFF capacitance	$C_{NC(OFF)}$, $C_{NO(OFF)}$	V_{NC} or $V_{NO} = V_+$ or GND, Switch OFF,	See Figure 16	25°C	2.5 V		18	pF	
NC, NO ON capacitance	$C_{NC(ON)}$, $C_{NO(ON)}$	V_{NC} or $V_{NO} = V_+$ or GND, Switch ON,	See Figure 16	25°C	2.5 V		55	pF	
COM ON capacitance	$C_{COM(ON)}$	$V_{COM} = V_+$ or GND, Switch ON,	See Figure 16	25°C	2.5 V		55	pF	
Digital input capacitance	C_I	$V_I = V_+$ or GND,	See Figure 16	25°C	2.5 V		2	pF	
Bandwidth	BW	$R_L = 50\ \Omega$, Switch ON,	See Figure 19	25°C	2.5 V		90	MHz	
OFF isolation	O_{ISO}	$R_L = 50\ \Omega$, $f = 1\text{ MHz}$,	Switch OFF, See Figure 20	25°C	2.5 V		-63	dB	
Crosstalk	X_{TALK}	$R_L = 50\ \Omega$, $f = 1\text{ MHz}$,	Switch ON, See Figure 21	25°C	2.5 V		-63	dB	
Total harmonic distortion	THD	$R_L = 600\ \Omega$, $C_L = 50\text{ pF}$,	$f = 20\text{ Hz to }20\text{ kHz}$, See Figure 23	25°C	2.5 V		0.02	%	
Supply									
Positive supply current	I_+	$V_I = V_+$ or GND,	Switch ON or OFF	25°C	2.7 V		10	20	nA
				Full				150	

(1) The algebraic convention, whereby the most negative value is a minimum and the most positive value is a maximum

TS5A4624
1-Ω SPDT ANALOG SWITCH
5-V/3.3-V SINGLE-CHANNEL 2:1 MULTIPLEXER/DEMULTIPLEXER

SLYS014A–DECEMBER 2005–REVISED AUGUST 2006

Electrical Characteristics for 1.8-V Supply⁽¹⁾

$V_+ = 1.65\text{ V to }1.95\text{ V}$, $T_A = -40^\circ\text{C to }85^\circ\text{C}$ (unless otherwise noted)

PARAMETER	SYMBOL	TEST CONDITIONS	T_A	V_+	MIN	TYP	MAX	UNIT	
Analog Switch									
Analog signal range	V_{COM}, V_{NO}, V_{NC}				0		V_+	V	
Peak ON resistance	r_{peak}	$0 \leq (V_{NO} \text{ or } V_{NC}) \leq V_+$, $I_{COM} = -2\text{ mA}$,	Switch ON, See Figure 13	25°C	1.65 V	5		Ω	
				Full		15			
ON-state resistance	r_{on}	$V_{NO} \text{ or } V_{NC} = 1.5\text{ V}$, $I_{COM} = -2\text{ mA}$,	Switch ON, See Figure 13	25°C	1.65 V	2	2.5	Ω	
				Full		3.5			
ON-state resistance match between channels	Δr_{on}	$V_{NO} \text{ or } V_{NC} = 1.5\text{ V}$, $I_{COM} = -2\text{ mA}$,	Switch ON, See Figure 13	25°C	1.65 V	0.15	0.4	Ω	
				Full		0.4			
ON-state resistance flatness	$r_{on(Flat)}$	$0 \leq (V_{NO} \text{ or } V_{NC}) \leq V_+$, $I_{COM} = -8\text{ mA}$,	Switch ON, See Figure 13	25°C	1.65 V	5		Ω	
				25°C		4.5			
				Full					
NC, NO OFF leakage current	$I_{NC(OFF)}, I_{NO(OFF)}$	$V_{NC} \text{ or } V_{NO} = 0.3\text{ V}$, $V_{COM} = 0.3\text{ V to }1.65\text{ V}$, or $V_{NC} \text{ or } V_{NO} = 1.65\text{ V}$, $V_{COM} = 0.3\text{ V to }1.65\text{ V}$,	Switch OFF, See Figure 14	25°C	1.95 V	-5	2	5	nA
				Full		-20	20		
	$I_{NC(PWROFF)}, I_{NO(PWROFF)}$	$V_{NC} \text{ or } V_{NO} = 0 \text{ to } 1.95\text{ V}$, $V_{COM} = 1.95\text{ V to } 0$,	Switch OFF, See Figure 14	25°C	0 V	-1	0.1	1	μA
				Full		-5	5		
NC, NO ON leakage current	$I_{NC(ON)}, I_{NO(ON)}$	$V_{NC} \text{ or } V_{NO} = 0.3\text{ V}$, $V_{COM} = \text{Open}$, or $V_{NC} \text{ or } V_{NO} = 1.65\text{ V}$, $V_{COM} = \text{Open}$,	Switch ON, See Figure 15	25°C	1.95 V	-5	2	5	nA
				Full		-20	20		
COM OFF leakage current	$I_{COM(PWROFF)}$	$V_{NC} \text{ or } V_{NO} = 1.95\text{ V to } 0$, $V_{COM} = 0 \text{ to } 1.95\text{ V}$,	Switch OFF, See Figure 14	25°	0 V	-1	0.1	1	μA
				Full		-5	5		
COM ON leakage current	$I_{COM(ON)}$	$V_{NC} \text{ or } V_{NO} = \text{Open}$, $V_{COM} = 0.3\text{ V}$, or $V_{NC} \text{ or } V_{NO} = \text{Open}$, $V_{COM} = 1.65\text{ V}$,	Switch ON, See Figure 15	25°C	1.95 V	-5	2	5	nA
				Full		-20	20		
Digital Input (IN)									
Input logic high	V_{IH}			Full		1.5	5.5	V	
Input logic low	V_{IL}			Full		0	0.6	V	
Input leakage current	I_{IH}, I_{IL}	$V_I = 5.5\text{ V or } 0$		25°C	1.95 V	-2	2	nA	
				Full		20	20		

(1) The algebraic convention, whereby the most negative value is a minimum and the most positive value is a maximum

Electrical Characteristics for 1.8-V Supply⁽¹⁾ (Continued)

$V_+ = 1.65\text{ V to }1.95\text{ V}$, $T_A = -40^\circ\text{C to }85^\circ\text{C}$ (unless otherwise noted)

PARAMETER	SYMBOL	TEST CONDITIONS	T_A	V_+	MIN	TYP	MAX	UNIT	
Dynamic									
Turn-on time	t_{ON}	$V_{COM} = V_+$, $R_L = 50\ \Omega$,	$C_L = 35\ \text{pF}$, See Figure 17	25°C	1.8 V	17	35	65	ns
				Full	1.65 V to 1.95 V	15		70	
Turn-off time	t_{OFF}	$V_{COM} = V_+$, $R_L = 50\ \Omega$,	$C_L = 35\ \text{pF}$, See Figure 17	25°C	1.8 V	3	7	13	ns
				Full	1.65 V to 1.95 V	2		15	
Break-before-make time	t_{BBM}	$V_{NC} = V_{NO} = V_+$, $R_L = 50\ \Omega$,	$C_L = 35\ \text{pF}$, See Figure 18	25°C	1.8 V	15	33	60	ns
				Full	1.65 V to 1.95 V	15		65	
Charge injection	Q_C	$V_{GEN} = 0$, $R_{GEN} = 0$,	$C_L = 1\ \text{nF}$, See Figure 22	25°C	1.8 V		4	pC	
NC, NO OFF capacitance	$C_{NC(OFF)}$, $C_{NO(OFF)}$	V_{NC} or $V_{NO} = V_+$ or GND, Switch OFF,	See Figure 16	25°C	1.8 V		18	pF	
NC, NO ON capacitance	$C_{NC(ON)}$, $C_{NO(ON)}$	V_{NC} or $V_{NO} = V_+$ or GND, Switch ON,	See Figure 16	25°C	1.8 V		55	pF	
COM ON capacitance	$C_{COM(ON)}$	$V_{COM} = V_+$ or GND, Switch ON,	See Figure 16	25°C	1.8 V		55	pF	
Digital input capacitance	C_I	$V_I = V_+$ or GND,	See Figure 16	25°C	1.8 V		2	pF	
Bandwidth	BW	$R_L = 50\ \Omega$, Switch ON,	See Figure 19	25°C	1.8 V		90	MHz	
OFF isolation	O_{ISO}	$R_L = 50\ \Omega$, $f = 1\ \text{MHz}$,	Switch OFF, See Figure 20	25°C	1.8 V		63	dB	
Crosstalk	X_{TALK}	$R_L = 50\ \Omega$, $f = 1\ \text{MHz}$,	Switch ON, See Figure 21	25°C	1.8 V		63	dB	
Total harmonic distortion	THD	$R_L = 600\ \Omega$, $C_L = 50\ \text{pF}$,	$f = 20\ \text{Hz to }20\ \text{kHz}$, See Figure 23	25°C	1.8 V		0.05	%	
Supply									
Positive supply current	I_+	$V_I = V_+$ or GND,	Switch ON or OFF	25°C	1.95 V		5	15	μA
				Full				50	

(1) The algebraic convention, whereby the most negative value is a minimum and the most positive value is a maximum

TYPICAL PERFORMANCE

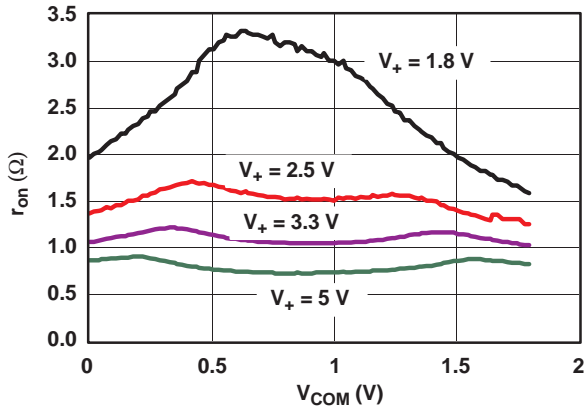

Figure 1. r_{on} vs V_{COM}

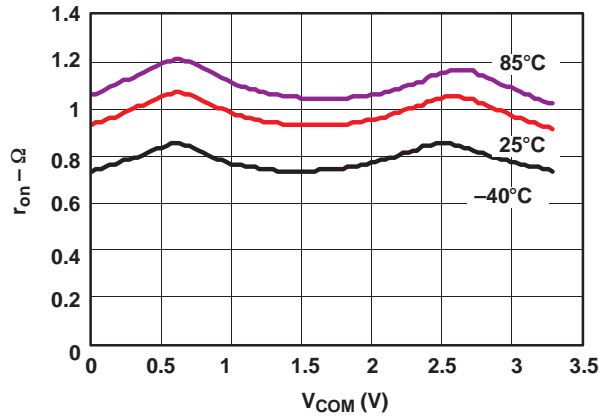

Figure 2. r_{on} vs V_{COM} ($V_+ = 3.3$ V)

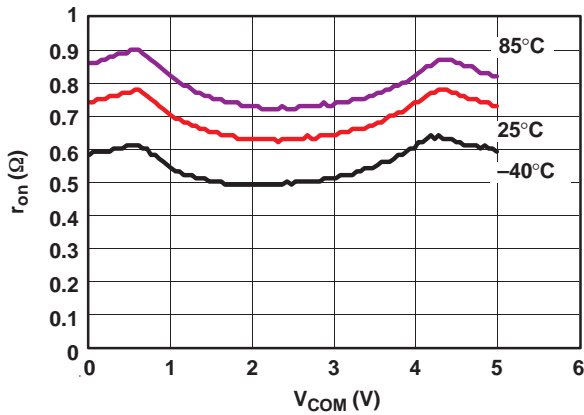

Figure 3. r_{on} vs V_{COM} ($V_+ = 5$ V)

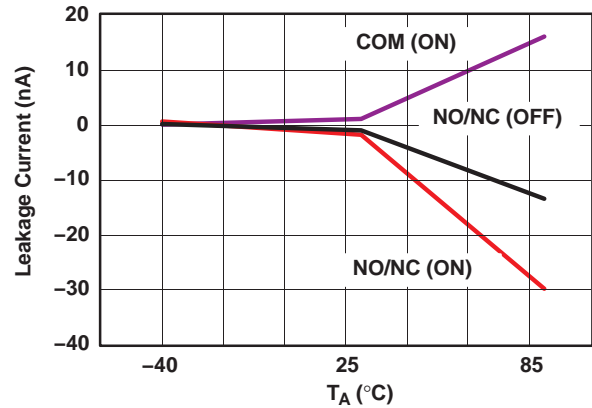

Figure 4. Leakage Current vs Temperature ($V_+ = 3.3$ V)

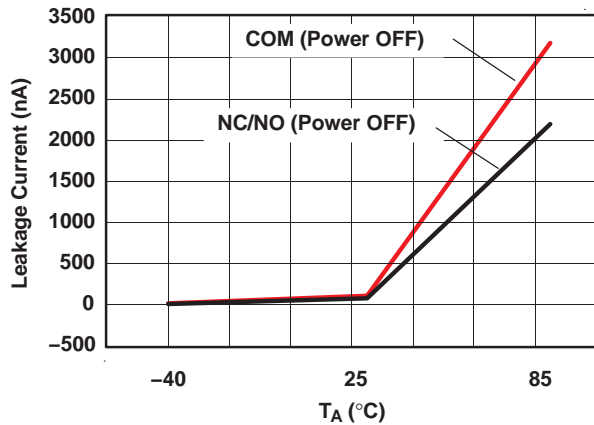

Figure 5. Leakage Current vs Temperature ($V_+ = 5$ V)

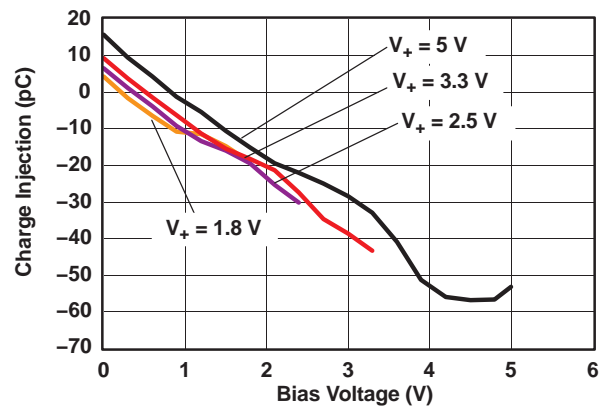

Figure 6. Charge Injection (Q_C) vs V_{COM}

TYPICAL PERFORMANCE (continued)

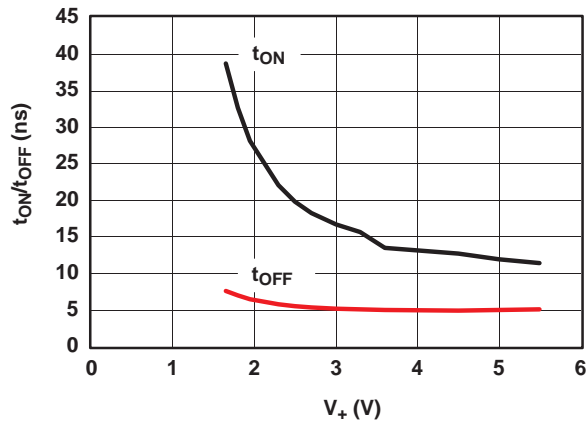

Figure 7. t_{ON} and t_{OFF} vs Supply Voltage

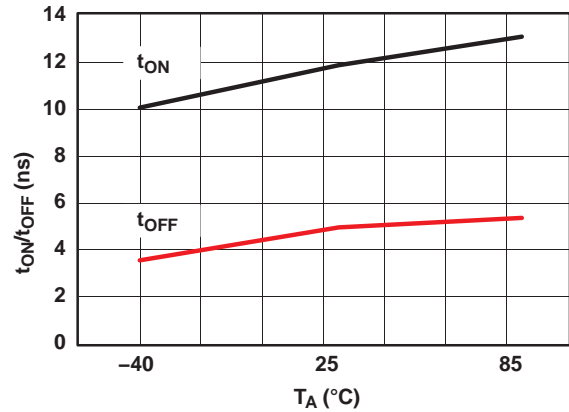

Figure 8. t_{ON} and t_{OFF} vs Temperature

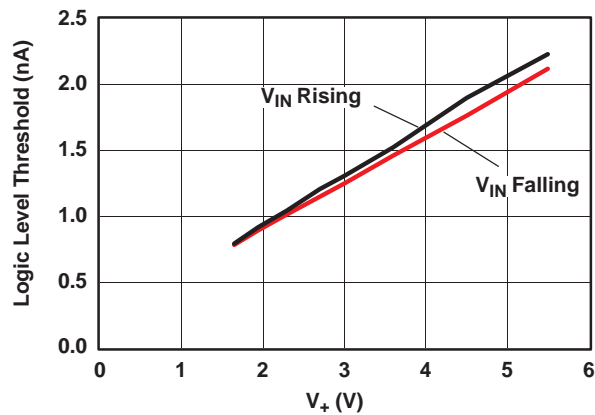

Figure 9. V_{IN} and t_{OFF} vs Supply Voltage

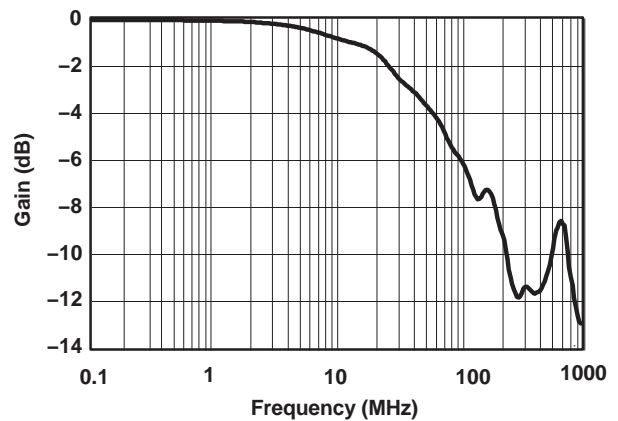

Figure 10. Bandwidth ($V_+ = 5\text{ V}$)

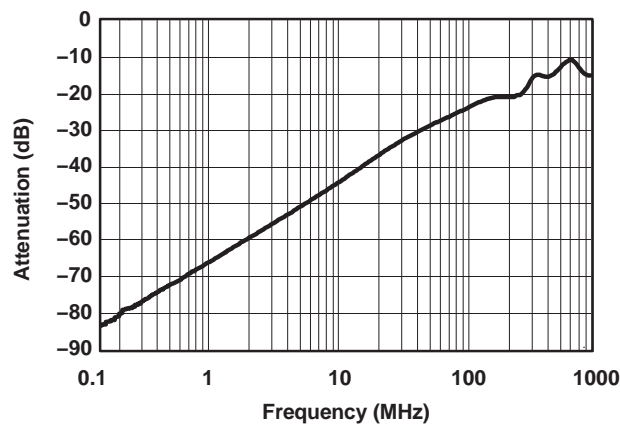

Figure 11. OFF Isolation vs Frequency

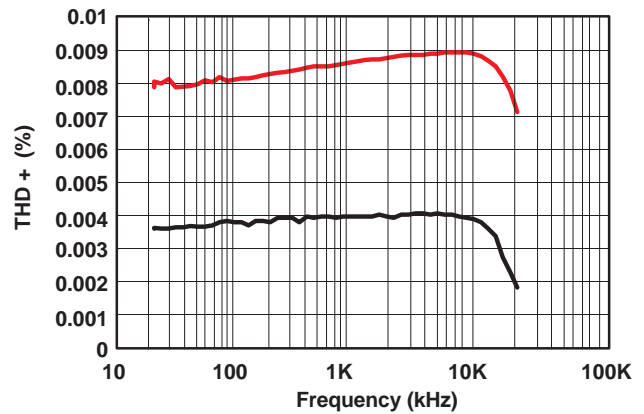

Figure 12. Total Harmonic Distortion vs Frequency ($V_+ = 5\text{ V}$)

TYPICAL PERFORMANCE (continued)

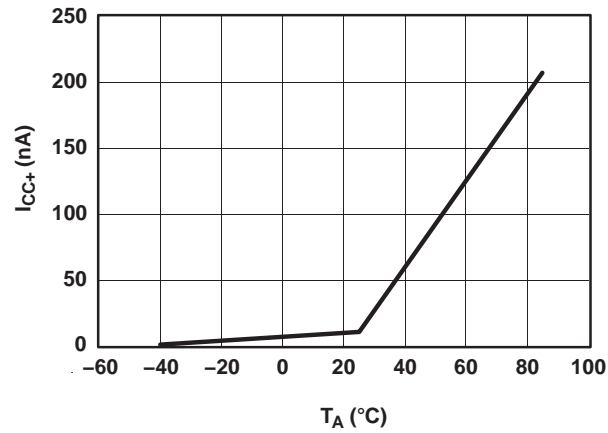

Figure 13. Current vs Temperature ($V_+ = 5$ V)

PIN DESCRIPTION

PIN NO.	NAME	DESCRIPTION
1	IN	Digital control to connect COM to NO
2	V ₊	Power supply
3	GND	Digital ground
4	NC	Normally closed
5	COM	Common
6	NO	Normally open

TS5A4624
1-Ω SPDT ANALOG SWITCH
5-V/3.3-V SINGLE-CHANNEL 2:1 MULTIPLEXER/DEMULTIPLEXER

SLYS014A–DECEMBER 2005–REVISED AUGUST 2006

PARAMETER DESCRIPTION

SYMBOL	DESCRIPTION
V_{COM}	Voltage at COM
V_{NC}	Voltage at NC
V_{NO}	Voltage at NO
r_{on}	Resistance between COM and NC or COM and NO ports when the channel is ON
r_{peak}	Peak ON-state resistance over a specified voltage range
Δr_{on}	Difference of r_{on} between channels
$r_{on(flat)}$	Difference between the maximum and minimum value of r_{on} in a channel over the specified range of conditions
$I_{NC(OFF)}$	Leakage current measured at the NC port, with the corresponding channel (NC to COM) in the OFF state under worst-case input and output conditions
$I_{NC(PWROFF)}$	Leakage current measured at the NC port during the power-down condition, $V_+ = 0$
$I_{NO(OFF)}$	Leakage current measured at the NO port, with the corresponding channel (NO to COM) in the OFF state under worst-case input and output conditions
$I_{NO(PWROFF)}$	Leakage current measured at the NO port during the power-down condition, $V_+ = 0$
$I_{NC(ON)}$	Leakage current measured at the NC port, with the corresponding channel (NC to COM) in the ON state and the output (COM) being open
$I_{NO(ON)}$	Leakage current measured at the NO port, with the corresponding channel (NO to COM) in the ON state and the output (COM) being open
$I_{COM(ON)}$	Leakage current measured at the COM port, with the corresponding channel (COM to NO or COM to NC) in the ON state and the output (NC or NO) being open
$I_{COM(PWROFF)}$	Leakage current measured at the COM port during the power-down condition, $V_+ = 0$
V_{IH}	Minimum input voltage for logic high for the control input (IN)
V_{IL}	Maximum input voltage for logic low for the control input (IN)
V_I	Voltage at IN
I_{IH}, I_{IL}	Leakage current measured at IN
t_{ON}	Turn-on time for the switch. This parameter is measured under the specified range of conditions and by the propagation delay between the digital control (IN) signal and analog outputs (COM, NC, or NO) signal when the switch is turning ON.
t_{OFF}	Turn-off time for the switch. This parameter is measured under the specified range of conditions and by the propagation delay between the digital control (IN) signal and analog outputs (COM, NC, or NO) signal when the switch is turning OFF.
t_{BBM}	Break-before-make time. This parameter is measured under the specified range of conditions and by the propagation delay between the output of two adjacent analog channels (NC and NO) when the control signal changes state.
Q_C	Charge injection is a measurement of unwanted signal coupling from the control (IN) input to the analog (NC, NO, or COM) output. This is measured in coulomb (C) and measured by the total charge induced due to switching of the control input. Charge injection, $Q_C = C_L \times \Delta V_O$, C_L is the load capacitance and ΔV_O is the change in analog output voltage.
$C_{NC(OFF)}$	Capacitance at the NC port when the corresponding channel (NC to COM) is OFF
$C_{NO(OFF)}$	Capacitance at the NO port when the corresponding channel (NO to COM) is OFF
$C_{NC(ON)}$	Capacitance at the NC port when the corresponding channel (NC to COM) is ON
$C_{NO(ON)}$	Capacitance at the NO port when the corresponding channel (NO to COM) is ON
$C_{COM(ON)}$	Capacitance at the COM port when the corresponding channel (COM to NC or COM to NO) is ON
C_{IN}	Capacitance of IN
OISO	OFF isolation of the switch is a measurement OFF-state switch impedance. This is measured in dB in a specific frequency, with the corresponding channel (NC to COM or NO to COM) in the OFF state.
X_{TALK}	Crosstalk is a measurement of unwanted signal coupling from an ON channel to an OFF channel (NC to NO or NO to NC). This is measured in a specific frequency and in dB.
BW	Bandwidth of the switch. This is the frequency in which the gain of an ON channel is –3 dB below the DC gain.
THD	Total harmonic distortion describes the signal distortion caused by the analog switch. This is defined as the ratio or root mean square (RMS) value of the second, third, and higher harmonic to the absolute magnitude of the fundamental harmonic.
I_+	Static power-supply current with the control (IN) pin at V_+ or GND

PARAMETER MEASUREMENT INFORMATION

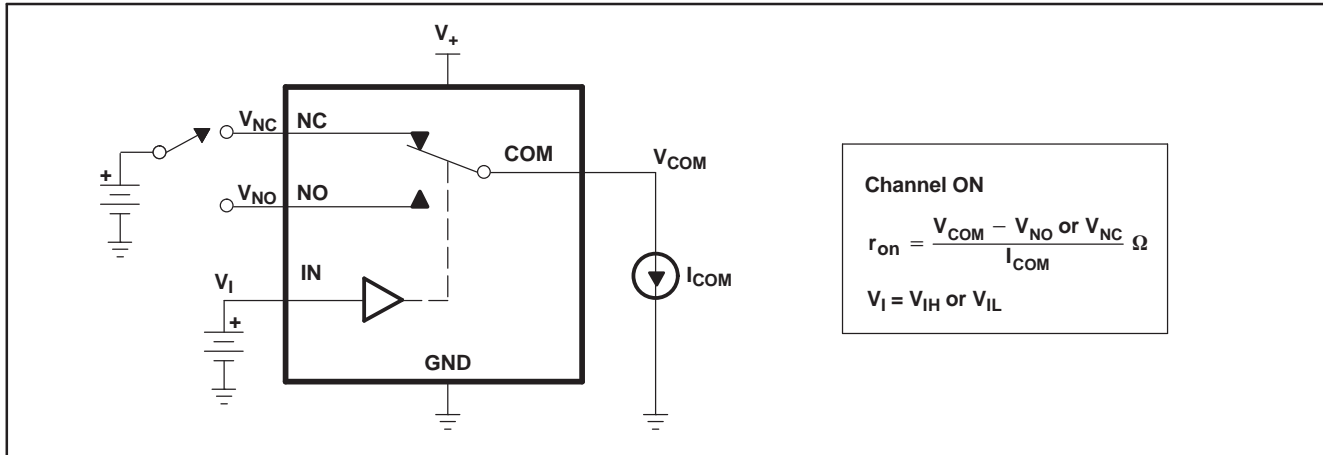

Figure 14. ON-State Resistance (r_{on})

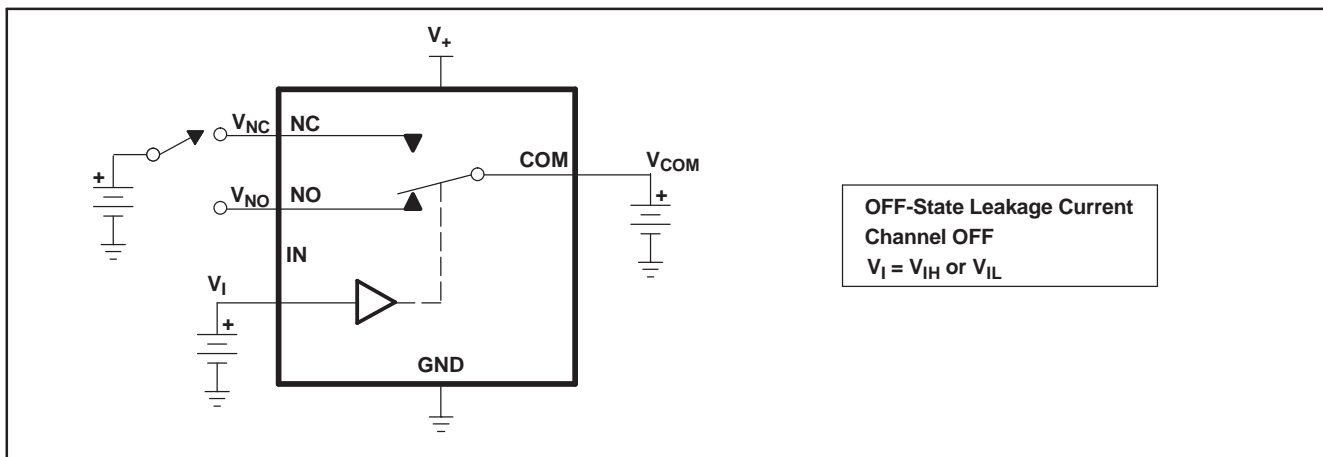

Figure 15. OFF-State Leakage Current ($I_{NC(OFF)}$, $I_{NC(PWROFF)}$, $I_{NO(OFF)}$, $I_{NO(PWROFF)}$, $I_{COM(OFF)}$, $I_{COM(PWROFF)}$)

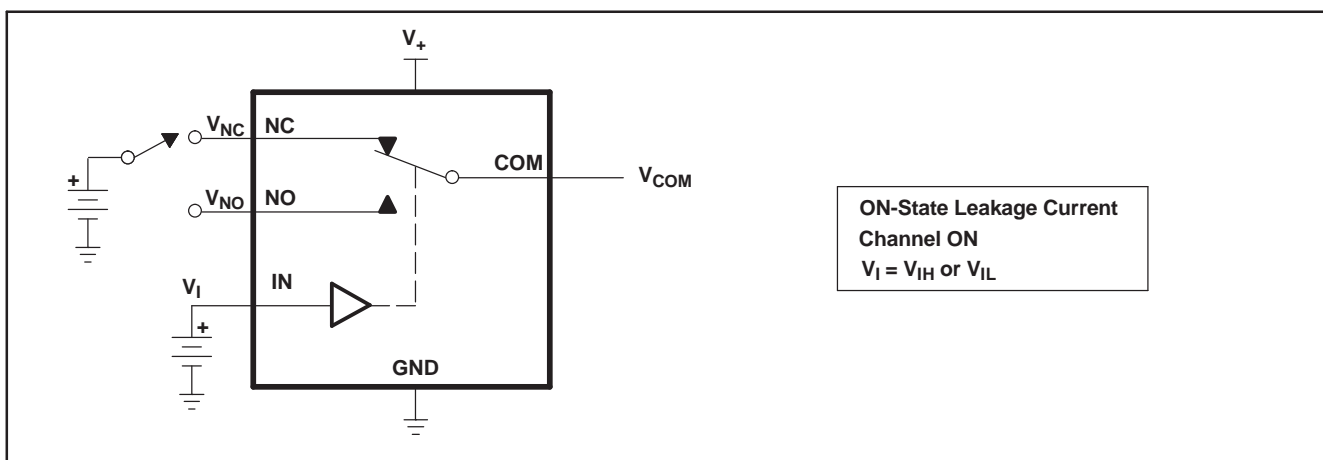

Figure 16. ON-State Leakage Current ($I_{COM(ON)}$, $I_{NC(ON)}$, $I_{NO(ON)}$)

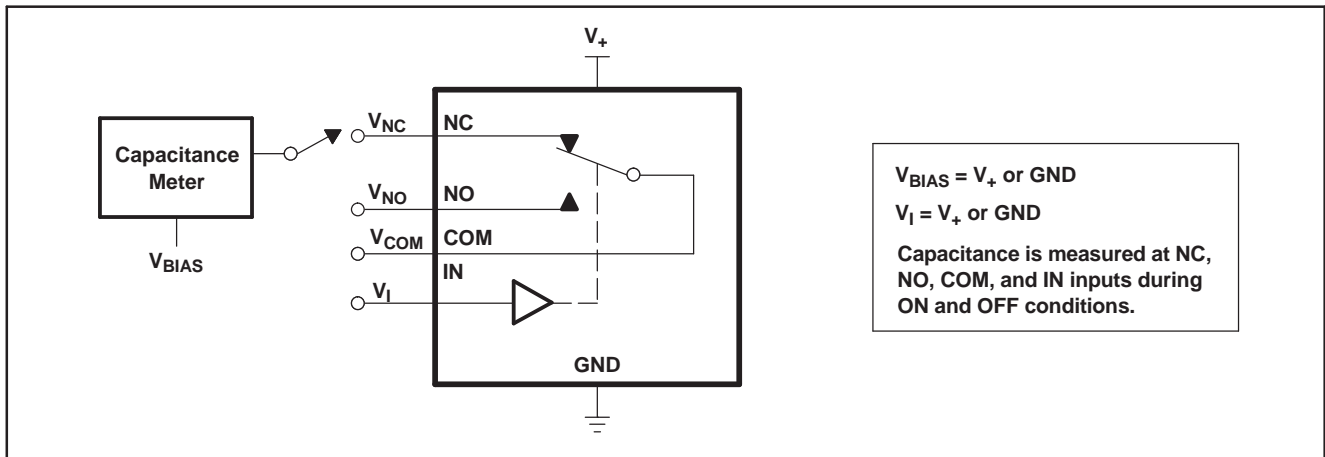
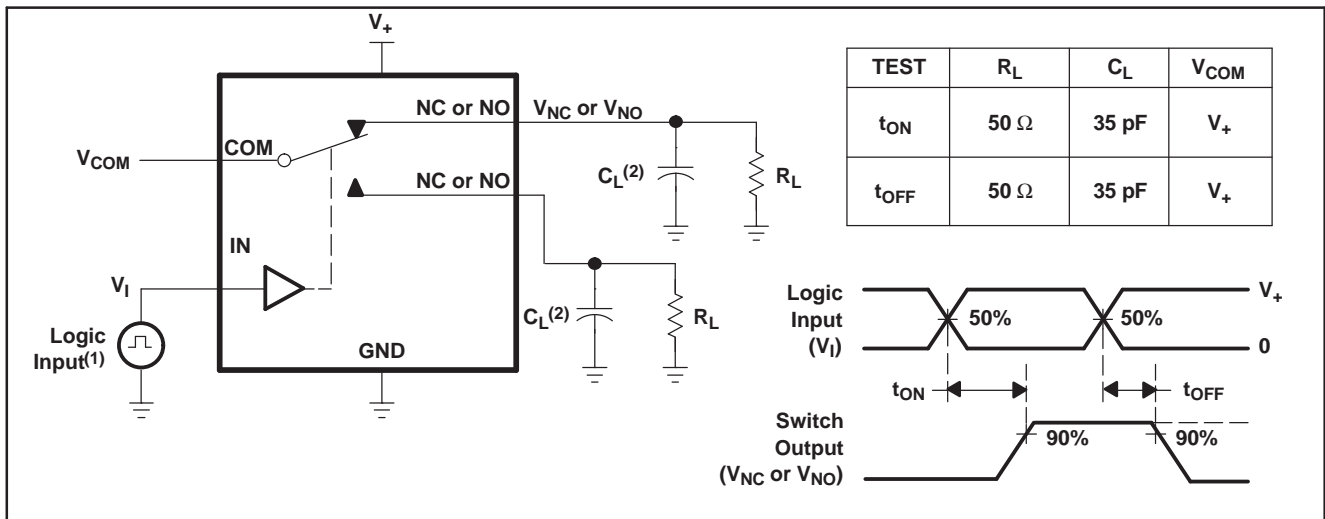
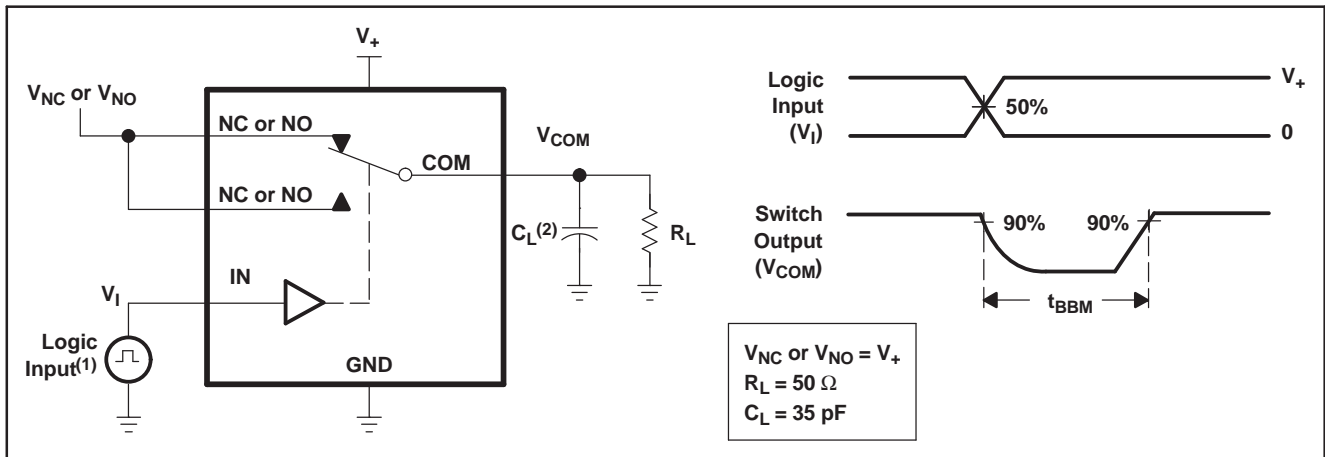

Figure 17. Capacitance (C_I , $C_{COM(ON)}$, $C_{NC(OFF)}$, $C_{NO(OFF)}$, $C_{NC(ON)}$, $C_{NO(ON)}$)



- (1) All input pulses are supplied by generators having the following characteristics: PRR ≤ 10 MHz, $Z_O = 50 \Omega$, $t_r < 5 \text{ ns}$, $t_f < 5 \text{ ns}$.
- (2) C_L includes probe and jig capacitance.

Figure 18. Turn-On (t_{ON}) and Turn-Off Time (t_{OFF})



- (1) All input pulses are supplied by generators having the following characteristics: $PRR \leq 10 \text{ MHz}$, $Z_O = 50 \Omega$, $t_r < 5 \text{ ns}$, $t_f < 5 \text{ ns}$.
- (2) C_L includes probe and jig capacitance.

Figure 19. Break-Before-Make Time (t_{BBM})

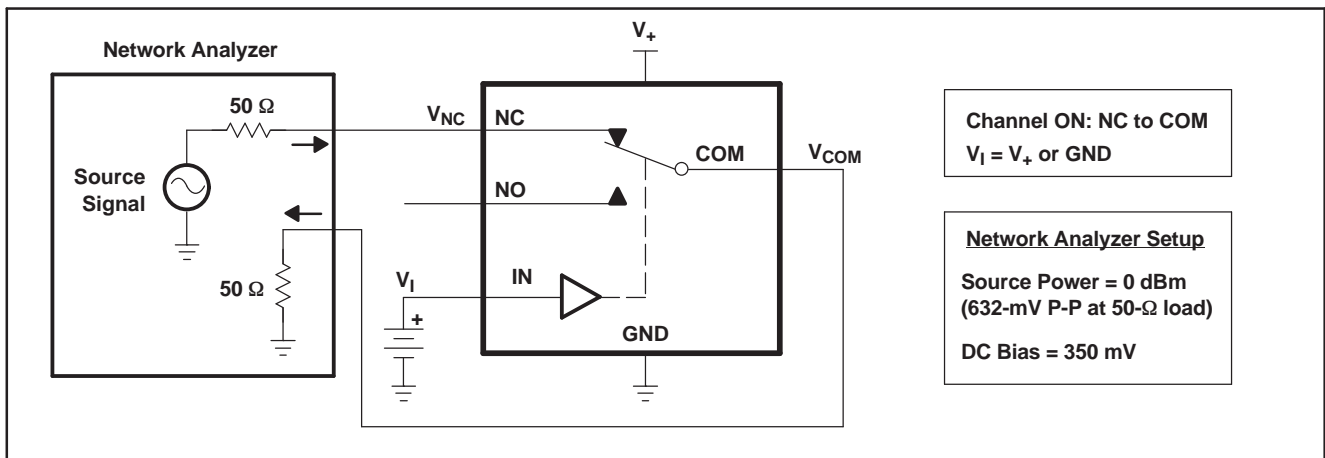

Figure 20. Bandwidth (BW)

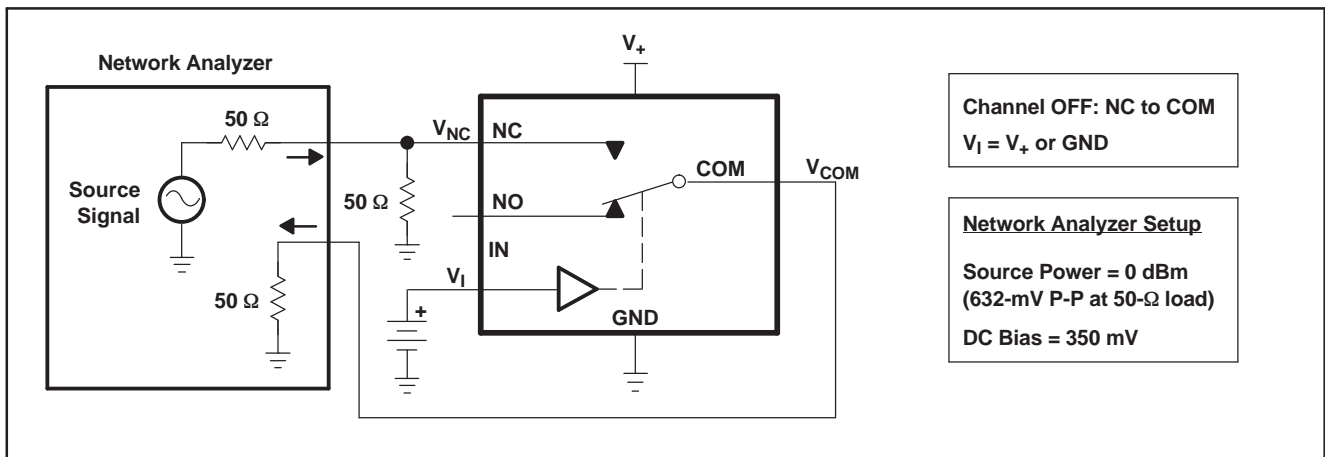

Figure 21. OFF Isolation (OISO)

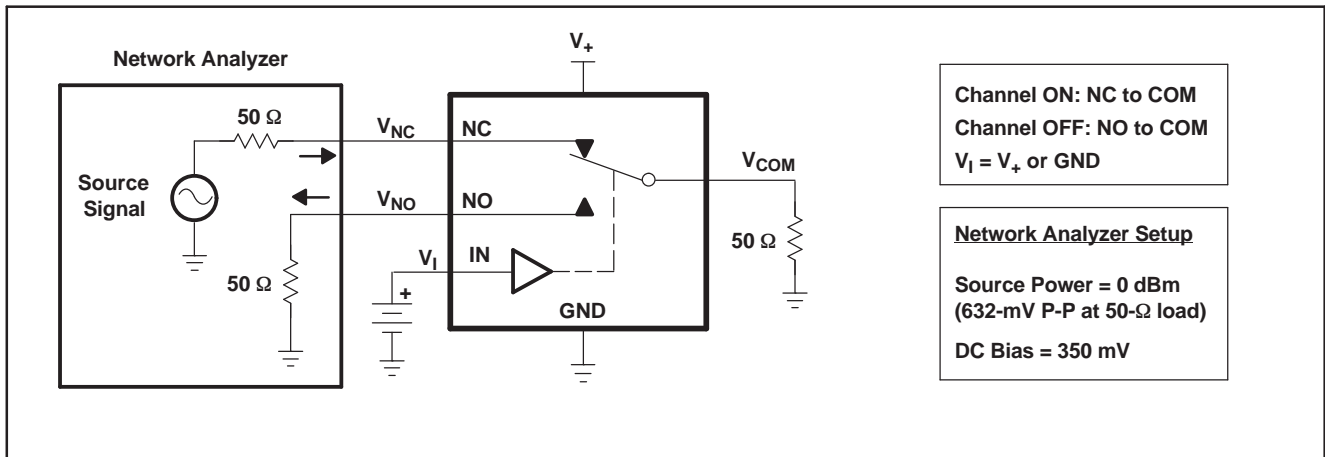
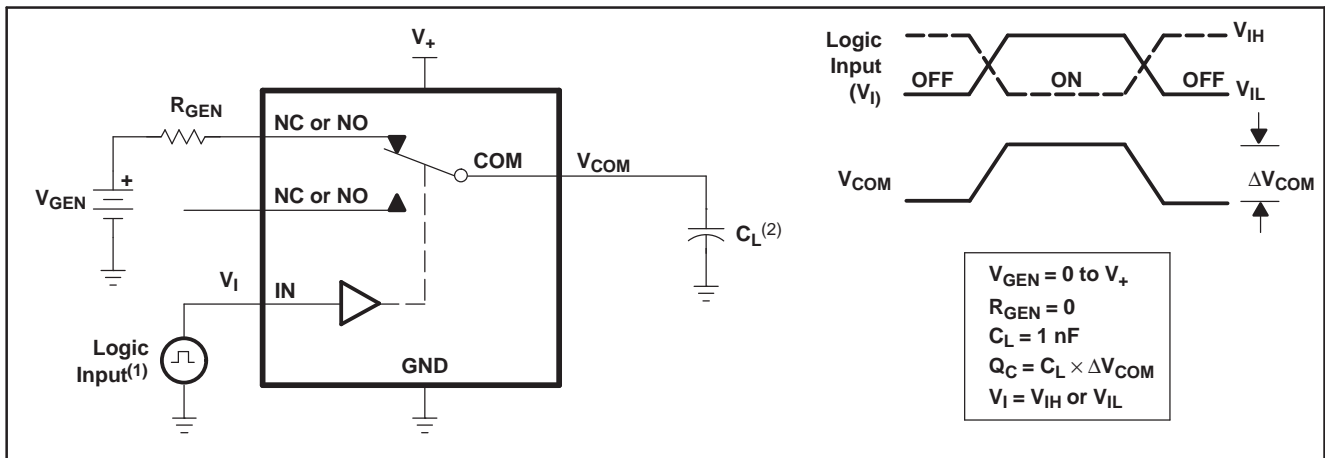
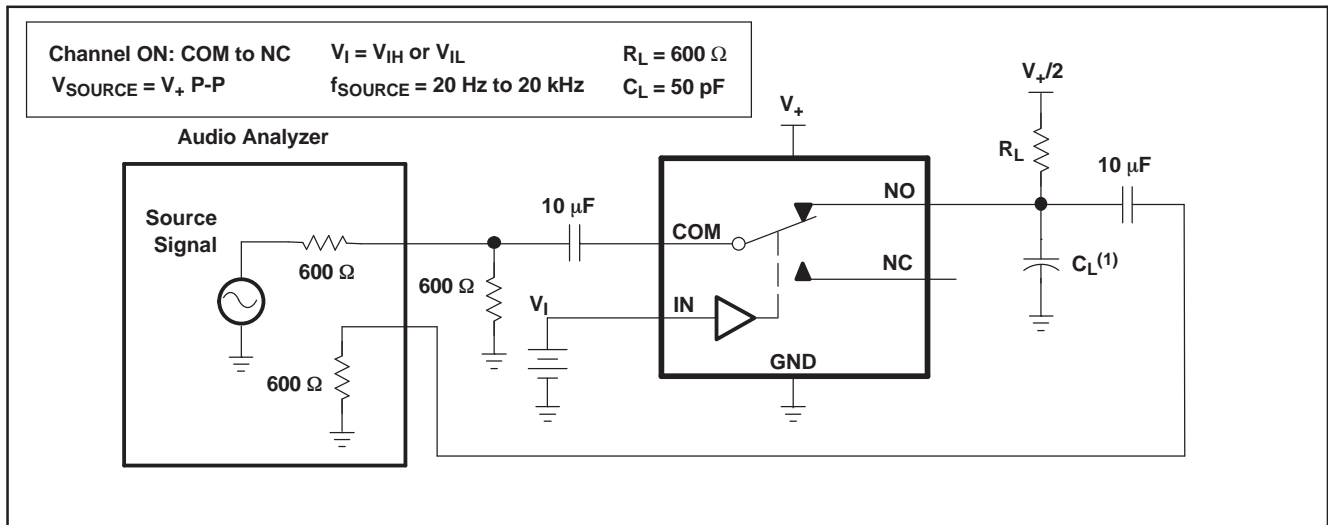

Figure 22. Crosstalk (X_{TALK})



- (1) All input pulses are supplied by generators having the following characteristics: PRR \leq 10 MHz, $Z_O = 50 \Omega$, $t_r < 5$ ns, $t_f < 5$ ns.
- (2) C_L includes probe and jig capacitance.

Figure 23. Charge Injection (Q_C)



(1) C_L includes probe and jig capacitance.

Figure 24. Total Harmonic Distortion (THD)

PACKAGING INFORMATION

Orderable Device	Status (1)	Package Type	Package Drawing	Pins	Package Qty	Eco Plan (2)	Lead finish/ Ball material (6)	MSL Peak Temp (3)	Op Temp (°C)	Device Marking (4/5)	Samples
TS5A4624DCKR	ACTIVE	SC70	DCK	6	3000	RoHS & Green	NIPDAU	Level-1-260C-UNLIM	-40 to 85	(JWF, JWR)	Samples
TS5A4624DCKT	LIFEBUY	SC70	DCK	6	250	RoHS & Green	NIPDAU	Level-1-260C-UNLIM	-40 to 85	JWR	
TS5A4624DCKTG4	LIFEBUY	SC70	DCK	6	250	RoHS & Green	NIPDAU	Level-1-260C-UNLIM	-40 to 85	JWR	

(1) The marketing status values are defined as follows:

ACTIVE: Product device recommended for new designs.

LIFEBUY: TI has announced that the device will be discontinued, and a lifetime-buy period is in effect.

NRND: Not recommended for new designs. Device is in production to support existing customers, but TI does not recommend using this part in a new design.

PREVIEW: Device has been announced but is not in production. Samples may or may not be available.

OBSOLETE: TI has discontinued the production of the device.

(2) **RoHS:** TI defines "RoHS" to mean semiconductor products that are compliant with the current EU RoHS requirements for all 10 RoHS substances, including the requirement that RoHS substance do not exceed 0.1% by weight in homogeneous materials. Where designed to be soldered at high temperatures, "RoHS" products are suitable for use in specified lead-free processes. TI may reference these types of products as "Pb-Free".

RoHS Exempt: TI defines "RoHS Exempt" to mean products that contain lead but are compliant with EU RoHS pursuant to a specific EU RoHS exemption.

Green: TI defines "Green" to mean the content of Chlorine (Cl) and Bromine (Br) based flame retardants meet JS709B low halogen requirements of <=1000ppm threshold. Antimony trioxide based flame retardants must also meet the <=1000ppm threshold requirement.

(3) MSL, Peak Temp. - The Moisture Sensitivity Level rating according to the JEDEC industry standard classifications, and peak solder temperature.

(4) There may be additional marking, which relates to the logo, the lot trace code information, or the environmental category on the device.

(5) Multiple Device Markings will be inside parentheses. Only one Device Marking contained in parentheses and separated by a "~" will appear on a device. If a line is indented then it is a continuation of the previous line and the two combined represent the entire Device Marking for that device.

(6) Lead finish/Ball material - Orderable Devices may have multiple material finish options. Finish options are separated by a vertical ruled line. Lead finish/Ball material values may wrap to two lines if the finish value exceeds the maximum column width.

Important Information and Disclaimer:The information provided on this page represents TI's knowledge and belief as of the date that it is provided. TI bases its knowledge and belief on information provided by third parties, and makes no representation or warranty as to the accuracy of such information. Efforts are underway to better integrate information from third parties. TI has taken and continues to take reasonable steps to provide representative and accurate information but may not have conducted destructive testing or chemical analysis on incoming materials and chemicals. TI and TI suppliers consider certain information to be proprietary, and thus CAS numbers and other limited information may not be available for release.

In no event shall TI's liability arising out of such information exceed the total purchase price of the TI part(s) at issue in this document sold by TI to Customer on an annual basis.

TAPE AND REEL INFORMATION

QUADRANT ASSIGNMENTS FOR PIN 1 ORIENTATION IN TAPE

*All dimensions are nominal

Device	Package Type	Package Drawing	Pins	SPQ	Reel Diameter (mm)	Reel Width W1 (mm)	A0 (mm)	B0 (mm)	K0 (mm)	P1 (mm)	W (mm)	Pin1 Quadrant
TS5A4624DCKR	SC70	DCK	6	3000	180.0	8.4	2.41	2.41	1.2	4.0	8.0	Q3
TS5A4624DCKR	SC70	DCK	6	3000	178.0	9.0	2.4	2.5	1.2	4.0	8.0	Q3
TS5A4624DCKT	SC70	DCK	6	250	180.0	8.4	2.41	2.41	1.2	4.0	8.0	Q3

TAPE AND REEL BOX DIMENSIONS



*All dimensions are nominal

Device	Package Type	Package Drawing	Pins	SPQ	Length (mm)	Width (mm)	Height (mm)
TS5A4624DCKR	SC70	DCK	6	3000	202.0	201.0	28.0
TS5A4624DCKR	SC70	DCK	6	3000	180.0	180.0	18.0
TS5A4624DCKT	SC70	DCK	6	250	202.0	201.0	28.0

DCK0006A



PACKAGE OUTLINE

SOT - 1.1 max height

SMALL OUTLINE TRANSISTOR

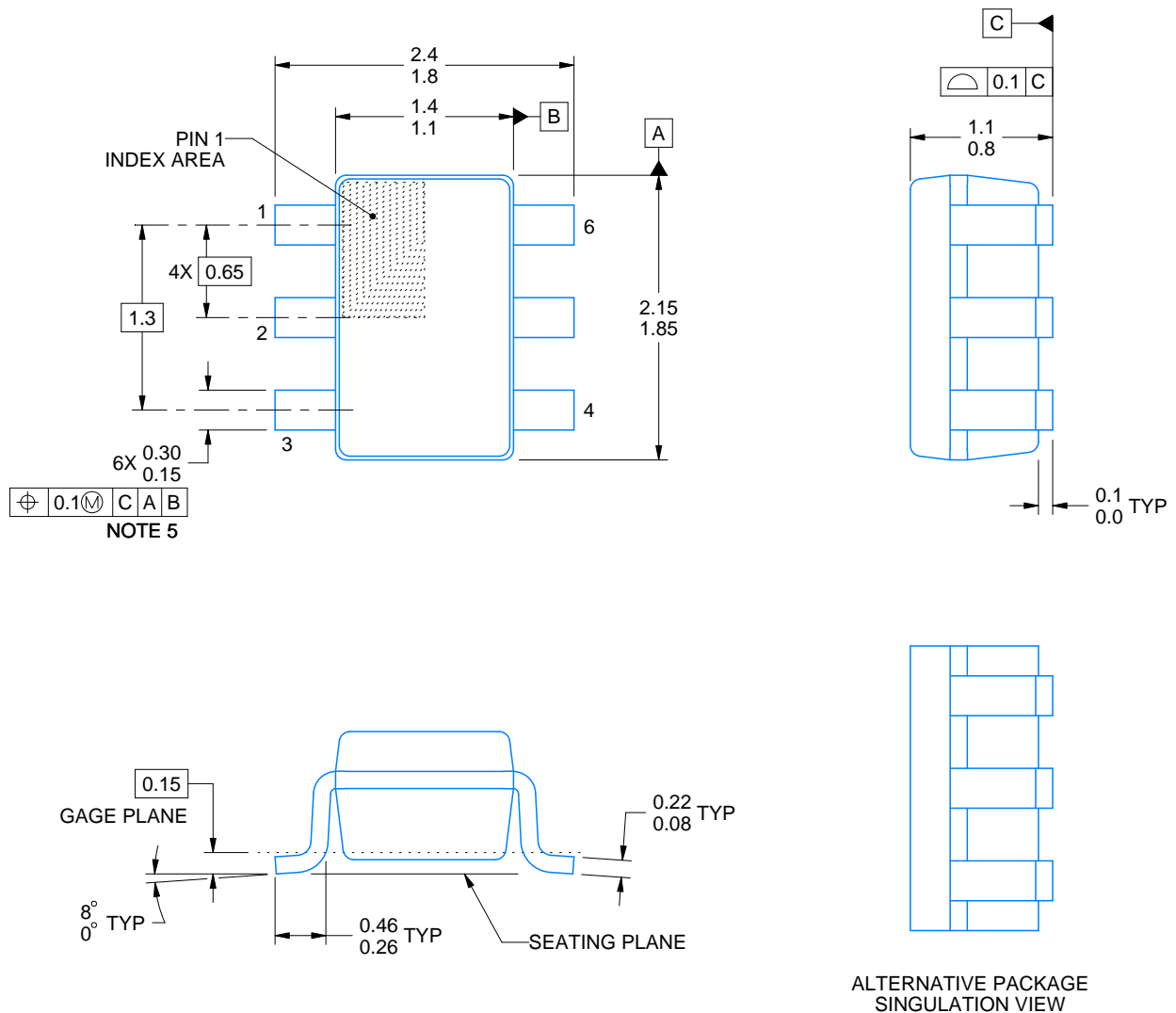

4214835/B 04/2024

NOTES:

1. All linear dimensions are in millimeters. Any dimensions in parenthesis are for reference only. Dimensioning and tolerancing per ASME Y14.5M.
2. This drawing is subject to change without notice.
3. Body dimensions do not include mold flash or protrusion. Mold flash and protrusion shall not exceed 0.15 per side.
4. Falls within JEDEC MO-203 variation AB.

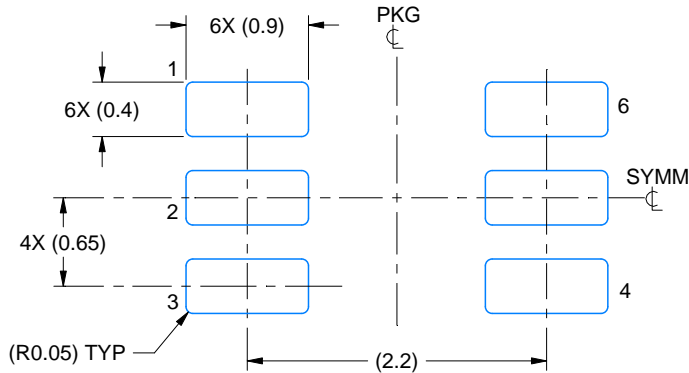

LAND PATTERN EXAMPLE
EXPOSED METAL SHOWN
SCALE:18X

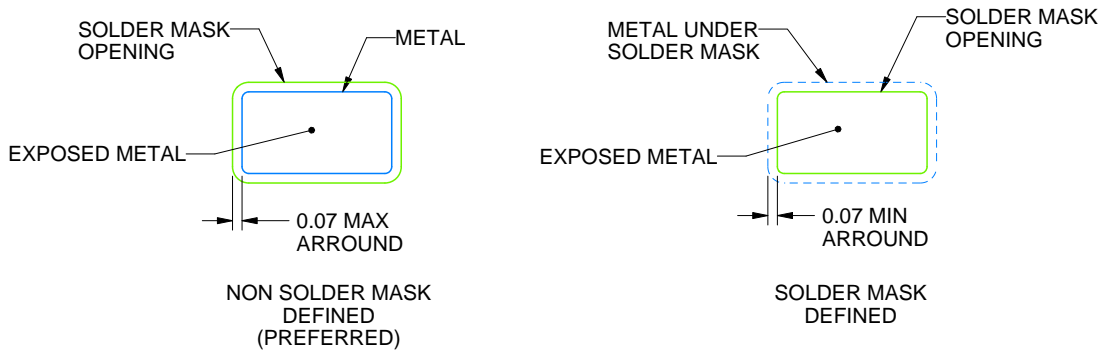

SOLDER MASK DETAILS

4214835/B 04/2024

NOTES: (continued)

- 5. Publication IPC-7351 may have alternate designs.
- 6. Solder mask tolerances between and around signal pads can vary based on board fabrication site.

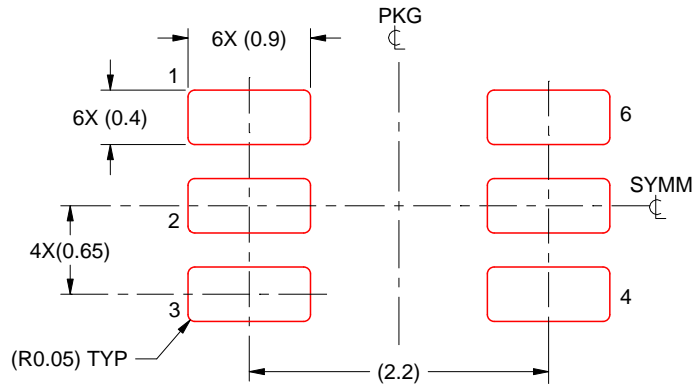

SOLDER PASTE EXAMPLE
BASED ON 0.125 THICK STENCIL
SCALE:18X

4214835/B 04/2024

NOTES: (continued)

7. Laser cutting apertures with trapezoidal walls and rounded corners may offer better paste release. IPC-7525 may have alternate design recommendations.
8. Board assembly site may have different recommendations for stencil design.

IMPORTANT NOTICE AND DISCLAIMER

TI PROVIDES TECHNICAL AND RELIABILITY DATA (INCLUDING DATA SHEETS), DESIGN RESOURCES (INCLUDING REFERENCE DESIGNS), APPLICATION OR OTHER DESIGN ADVICE, WEB TOOLS, SAFETY INFORMATION, AND OTHER RESOURCES "AS IS" AND WITH ALL FAULTS, AND DISCLAIMS ALL WARRANTIES, EXPRESS AND IMPLIED, INCLUDING WITHOUT LIMITATION ANY IMPLIED WARRANTIES OF MERCHANTABILITY, FITNESS FOR A PARTICULAR PURPOSE OR NON-INFRINGEMENT OF THIRD PARTY INTELLECTUAL PROPERTY RIGHTS.

These resources are intended for skilled developers designing with TI products. You are solely responsible for (1) selecting the appropriate TI products for your application, (2) designing, validating and testing your application, and (3) ensuring your application meets applicable standards, and any other safety, security, regulatory or other requirements.

These resources are subject to change without notice. TI grants you permission to use these resources only for development of an application that uses the TI products described in the resource. Other reproduction and display of these resources is prohibited. No license is granted to any other TI intellectual property right or to any third party intellectual property right. TI disclaims responsibility for, and you will fully indemnify TI and its representatives against, any claims, damages, costs, losses, and liabilities arising out of your use of these resources.

TI's products are provided subject to [TI's Terms of Sale](#) or other applicable terms available either on [ti.com](https://www.ti.com) or provided in conjunction with such TI products. TI's provision of these resources does not expand or otherwise alter TI's applicable warranties or warranty disclaimers for TI products.

TI objects to and rejects any additional or different terms you may have proposed.

Mailing Address: Texas Instruments, Post Office Box 655303, Dallas, Texas 75265
Copyright © 2024, Texas Instruments Incorporated

Looking for pricing, stock, or lifecycle information?

Click below to explore more details on WIN SOURCE:

 [View TS5A4624DCKR](#) on WIN SOURCE

 [Texas Instruments](#) Information

Optimize Your Supply Chain with WIN SOURCE Solutions

-  Global Sourcing Solution
-  Obsolete Management
-  Cost Control Management
-  Shortage Management
-  Alternative Solution
-  Excess Inventory Management