



**THE DATASHEET OF
TS5A3357DCURG4**



Single 5- Ω SP3T Analog Switch 5-V/3.3-V 3:1 Multiplexer/Demultiplexer

1 Features

- Specified Break-Before-Make Switching
- Low ON-State Resistance
- High Bandwidth
- Control Inputs Are 5.5-V Tolerant
- Low Charge Injection
- Excellent ON-State Resistance Matching
- Low Total Harmonic Distortion (THD)
- 1.65-V to 5.5-V Single-Supply Operation
- Latch-Up Performance Exceeds 100 mA Per JESD 78, Class II
- ESD Performance Tested Per JESD 22
 - 2000-V Human-Body Model (A114-B, Class II)
 - 1000-V Charged-Device Model (C101)

2 Applications

- Cell Phones
- PDAs
- Portable Instrumentation

3 Description

The TS5A3357 is a high-performance, 1-channel 3:1 analog switch that is designed to operate from 1.65 V to 5.5 V. The device offers a low ON-state resistance and low input/output capacitance and, thus, causes a low signal distortion. The break-before-make feature allows transferring of a signal from one port to another, with a minimal signal distortion. This device also offers a low charge injection which makes this device suitable for high-performance audio and data acquisition systems.

Device Information⁽¹⁾

PART NUMBER	PACKAGE	BODY SIZE (NOM)
TS5A3357	VSSOP (8)	2.3 mm x 2 mm

(1) For all available packages, see the orderable addendum at the end of the data sheet.

Logic Diagram

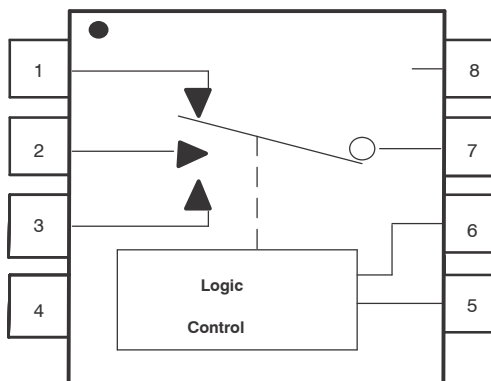

Table of Contents

1 Features	1	9.2 Functional Block Diagram	20
2 Applications	1	9.3 Feature Description	20
3 Description	1	9.4 Device Functional Modes	20
4 Revision History	2	10 Application and Implementation	21
5 Device Comparison Table	3	10.1 Application Information	21
6 Pin Configuration and Functions	4	10.2 Typical Application	21
7 Specifications	5	11 Power Supply Recommendations	22
7.1 Absolute Maximum Ratings	5	12 Layout	23
7.2 ESD Ratings	5	12.1 Layout Guidelines	23
7.3 Recommended Operating Conditions	5	12.2 Layout Example	23
7.4 Thermal Information	5	13 Device and Documentation Support	24
7.5 Electrical Characteristics for 5-V Supply	6	13.1 Device Support	24
7.6 Electrical Characteristics for 3.3-V Supply	8	13.2 Documentation Support	24
7.7 Electrical Characteristics for 2.5-V Supply	10	13.3 Receiving Notification of Documentation Updates	24
7.8 Electrical Characteristics for 1.8-V Supply	12	13.4 Community Resources	24
7.9 Typical Characteristics	14	13.5 Trademarks	24
8 Parameter Measurement Information	16	13.6 Electrostatic Discharge Caution	24
9 Detailed Description	20	13.7 Glossary	24
9.1 Overview	20	14 Mechanical, Packaging, and Orderable Information	24

4 Revision History

NOTE: Page numbers for previous revisions may differ from page numbers in the current version.

Changes from Revision A (December 2007) to Revision B	Page
<ul style="list-style-type: none"> Added <i>Device Information</i> table, <i>ESD Ratings</i> table, <i>Recommended Operating Conditions</i> table, <i>Feature Description</i> section, <i>Device Functional Modes</i>, <i>Application and Implementation</i> section, <i>Power Supply Recommendations</i> section, <i>Layout</i> section, <i>Device and Documentation Support</i> section, and <i>Mechanical, Packaging, and Orderable Information</i> section 	1

5 Device Comparison Table

Table 1. Summary of Characteristics⁽¹⁾

Configuration	Triple 3:1 Multiplexer/ Demultiplexer (1 × SP3T)
Number of channels	1
ON-state resistance (r_{on})	5 Ω
ON-state resistance match (Δr_{on})	0.1 Ω
ON-state resistance flatness ($r_{on(flat)}$)	6.5 Ω
Turn-on/turn-off time (t_{ON}/t_{OFF})	6.5 ns/3.7 ns
Break-before-make time (t_{BBM})	0.5 ns
Charge injection (Q_C)	3.4 pC
Bandwidth (BW)	334 MHz
OFF isolation (O_{ISO})	–82 dB at 10 MHz
Crosstalk (X_{TALK})	–62 dB at 10 MHz
Total harmonic distortion (THD)	0.05%
Leakage current ($I_{COM(OFF)}$)	$\pm 1 \mu A$

(1) $V_+ = 5 V$, $T_A = 25^\circ C$

6 Pin Configuration and Functions

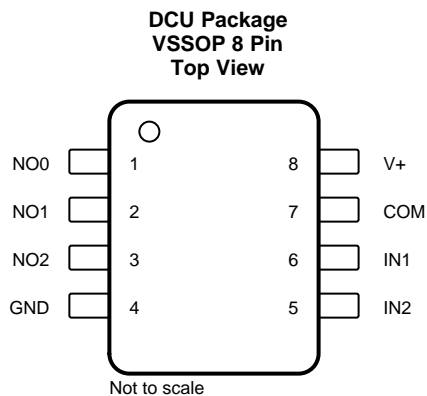

Pin Functions

PIN		DESCRIPTION
NAME	NO.	
NO0	1	Normally open
NO1	2	Normally open
NO2	3	Normally open
GND	4	Digital ground
IN2	5	Digital control to connect COM to NO
IN1	6	Digital control to connect COM to NO
COM	7	Common
V+	8	Power supply

7 Specifications

7.1 Absolute Maximum Ratings

over operating free-air temperature range (unless otherwise noted)⁽¹⁾

		MIN	MAX	UNIT
V ₊	Supply voltage range ⁽²⁾	-0.5	6.5	V
V _{NO} V _{COM}	Analog voltage range ^{(2) (3) (4)}	-0.5	V ₊ + 0.5	V
I _K	Analog port diode current V _{NO} , V _{COM} < 0 or V _{NO} , V _{COM} > V ₊	-50	50	mA
I _{NO} I _{COM}	On-state switch current V _{NO} , V _{COM} = 0 to V ₊	-100	100	mA
V _I	Digital input voltage range ^{(2) (3)}	-0.5	6.5	V
I _{IK}	Digital input clamp current V _I < 0	-50		mA
I ₊	Continuous current through V ₊		100	mA
I _{GND}	Continuous current through GND	-100	100	mA
T _{stg}	Storage temperature range	-65	150	°C

- (1) Stresses beyond those listed under *Absolute Maximum Ratings* may cause permanent damage to the device. These are stress ratings only, which do not imply functional operation of the device at these or any other conditions beyond those indicated under *Recommended Operating Conditions*. Exposure to absolute-maximum-rated conditions for extended periods may affect device reliability.
- (2) All voltages are with respect to ground, unless otherwise specified.
- (3) The input and output voltage ratings may be exceeded if the input and output clamp-current ratings are observed.
- (4) This value is limited to 5.5 V maximum.

7.2 ESD Ratings

		VALUE	UNIT
V _(ESD)	Electrostatic discharge	Human-body model (HBM), per ANSI/ESDA/JEDEC JS-001 ⁽¹⁾	±2000
		Charged-device model (CDM), per JEDEC specification JESD22-C101 ⁽²⁾	±1000

- (1) JEDEC document JEP155 states that 500-V HBM allows safe manufacturing with a standard ESD control process.
- (2) JEDEC document JEP157 states that 250-V CDM allows safe manufacturing with a standard ESD control process.

7.3 Recommended Operating Conditions

over operating free-air temperature range (unless otherwise noted)

		MIN	MAX	UNIT
V ₊	Supply voltage range	1.65	5.5	V
V _{NO} V _{COM}	Analog voltage range	0	V ₊	
V _I	Digital input voltage range	0	5.5	

7.4 Thermal Information

THERMAL METRIC ⁽¹⁾		TS5A3357	UNIT
		DCU (VSSOP)	
		8 PINS	
R _{θJA}	Junction-to-ambient thermal resistance	206.5	°C/W
R _{θJC(top)}	Junction-to-case (top) thermal resistance	78.7	°C/W
R _{θJB}	Junction-to-board thermal resistance	85.3	°C/W
ψ _{JT}	Junction-to-top characterization parameter	7.3	°C/W
ψ _{JB}	Junction-to-board characterization parameter	84.8	°C/W
R _{θJC(bot)}	Junction-to-case (bottom) thermal resistance	n/a	°C/W

- (1) For more information about traditional and new thermal metrics, see the [Semiconductor and IC Package Thermal Metrics](#) application report.

7.5 Electrical Characteristics for 5-V Supply⁽¹⁾

$V_+ = 4.5\text{ V to }5.5\text{ V}$, $T_A = -40^\circ\text{C to }85^\circ\text{C}$ (unless otherwise noted)

PARAMETER	SYMBOL	TEST CONDITIONS	T_A	V_+	MIN	TYP	MAX	UNIT	
Analog Switch									
Peak ON resistance	r_{peak}	$0 \leq V_{\text{NO}} \leq V_+$, $I_{\text{COM}} = -30\text{ mA}$, Switch ON, See Figure 13	Full	4.5 V			15	Ω	
ON-state resistance	r_{on}	$V_{\text{NO}} = 0$, $I_{\text{COM}} = 30\text{ mA}$	25°C	4.5 V			5	7	Ω
			Full				7		
		$V_{\text{NO}} = 2.4\text{ V}$, $I_{\text{COM}} = -30\text{ mA}$	25°C				6	12	
			Full				12		
$V_{\text{NO}} = 4.5\text{ V}$, $I_{\text{COM}} = -30\text{ mA}$	25°C	7	15						
	Full	15							
ON-state resistance match between channels	Δr_{on}	$V_{\text{NO}} = 3.15\text{ V}$, $I_{\text{COM}} = -30\text{ mA}$, Switch ON, See Figure 13	25°C	4.5 V		0.1		Ω	
ON-state resistance flatness	$r_{\text{on(flat)}}$	$0 \leq V_{\text{NO}} \leq V_+$, $I_{\text{COM}} = -30\text{ mA}$, Switch ON, See Figure 13	25°C	5 V		6.5		Ω	
NO OFF leakage current	$I_{\text{NO(OFF)}}$	$V_{\text{NO}} = 0\text{ to }V_+$, $V_{\text{COM}} = V_+\text{ to }0$, Switch OFF, See Figure 14	25°C	5.5 V			-0.1	0.1	μA
			Full				-1	1	
COM OFF leakage current	$I_{\text{COM(OFF)}}$	$V_{\text{COM}} = 0\text{ to }V_+$, $V_{\text{NO}} = V_+\text{ to }0$, Switch OFF, See Figure 14	25°C	0			-0.1	0.1	μA
			Full				-1	1	
NO ON leakage current	$I_{\text{NO(ON)}}$	$V_{\text{NO}} = 0\text{ to }V_+$, $V_{\text{COM}} = \text{Open}$, Switch ON, See Figure 14	25°C	5.5 V			-0.1	0.1	μA
			Full				-1	1	
COM ON leakage current	$I_{\text{COM(ON)}}$	$V_{\text{NO}} = \text{Open}$, $V_{\text{COM}} = 0\text{ to }V_+$, Switch ON, See Figure 14	25°C	5.5 V			-0.1	0.1	μA
			Full				-1	1	
Digital Control Inputs (IN1, IN2)⁽²⁾									
Input logic high	V_{IH}		Full			$V_+ \times 0.7$	5.5	V	
Input logic low	V_{IL}		Full		0		$V_+ \times 0.3$	V	
Input leakage current	$I_{\text{IH}}, I_{\text{IL}}$	$V_{\text{I}} = 5.5\text{ V or }0$	25°C	5.5 V			0.1	μA	
			Full				1		

(1) The algebraic convention, whereby the most negative value is a minimum and the most positive value is a maximum

(2) All unused digital inputs of the device must be held at V_+ or GND to ensure proper device operation. Refer to the TI application report, *Implications of Slow or Floating CMOS Inputs*, literature number SCBA004.

Electrical Characteristics for 5-V Supply⁽¹⁾ (continued)
 $V_+ = 4.5\text{ V to }5.5\text{ V}$, $T_A = -40^\circ\text{C to }85^\circ\text{C}$ (unless otherwise noted)

PARAMETER	SYMBOL	TEST CONDITIONS	T_A	V_+	MIN	TYP	MAX	UNIT
Dynamic								
Turn-on time	t_{ON}	$V_{NO} = V_+$ or GND, $R_L = 500\ \Omega$, See Figure 16	25°C	5 V	1.5		6.5	ns
			Full	4.5 V to 5.5 V	1.5		7	
Turn-off time	t_{OFF}	$V_{NO} = V_+$ or GND, $R_L = 500\ \Omega$, See Figure 16	25°C	5 V	0.8		3.7	ns
			Full	4.5 V to 5.5 V	0.8		7	
Break-before-make time	t_{BBM}	$V_{NO} = V_+$, $R_L = 50\ \Omega$, See Figure 17	25°C	5 V	0.5			ns
			Full	4.5 V to 5.5 V	0.5			
Charge injection	Q_C	$V_{GEN} = 0$, $C_L = 0.1\text{ nF}$, See Figure 21	25°C	5 V		3.4		pC
NO OFF capacitance	$C_{NO(OFF)}$	$V_{NO} = V_+$ or GND, Switch OFF, See Figure 15	25°C	5 V		4.5		pF
COM OFF capacitance	$C_{COM(OFF)}$	$V_{NO} = V_+$ or GND, Switch OFF, See Figure 15	25°C	5 V		10.5		pF
NO ON capacitance	$C_{NO(ON)}$	$V_{NO} = V_+$ or GND, Switch ON, See Figure 15	25°C	5 V		17		pF
COM ON capacitance	$C_{COM(ON)}$	$V_{COM} = V_+$ or GND, Switch ON, See Figure 15	25°C	5 V		17		pF
Digital input capacitance	C_I	$V_I = V_+$ or GND, See Figure 15	25°C	5 V		3		pF
Bandwidth	BW	$R_L = 50\ \Omega$, Switch ON, See Figure 18	25°C	4.5 V to 5.5 V		334		MHz
OFF isolation	O_{ISO}	$R_L = 50\ \Omega$, $f = 10\text{ MHz}$, Switch OFF, See Figure 19	25°C	4.5 V to 5.5 V		-82		dB
Crosstalk	X_{TALK}	$R_L = 50\ \Omega$, $f = 10\text{ MHz}$, Switch ON, See Figure 20	25°C	4.5 V to 5.5 V		-62		dB
Supply								
Positive supply current	I_+	$V_I = V_+$ or GND, Switch ON or OFF	25°C	5.5 V			1	μA
			Full				10	

7.6 Electrical Characteristics for 3.3-V Supply⁽¹⁾

$V_+ = 3\text{ V to }3.6\text{ V}$, $T_A = -40^\circ\text{C to }85^\circ\text{C}$ (unless otherwise noted)

PARAMETER	SYMBOL	TEST CONDITIONS	T_A	V_+	MIN	TYP	MAX	UNIT
Analog Switch								
Peak ON resistance	r_{peak}	$0 \leq V_{\text{NO}} \leq V_+$, $I_{\text{COM}} = -24\text{ mA}$, Switch ON, See Figure 13	Full	3 V			25	Ω
ON-state resistance	r_{on}	$V_{\text{NO}} = 0\text{ V}$, $I_{\text{COM}} = 24\text{ mA}$ Switch ON, See Figure 13	25°C	3 V			6.5	9
			Full				9	
			25°C				9	20
			Full				20	
ON-state resistance match between channels	Δr_{on}	$V_{\text{NO}} = 2.1\text{ V}$, $I_{\text{COM}} = -24\text{ mA}$, Switch ON, See Figure 13	25°C	3 V		0.1	Ω	
ON-state resistance flatness	$r_{\text{on(Flat)}}$	$0 \leq V_{\text{NO}} \leq V_+$, $I_{\text{COM}} = -24\text{ mA}$, Switch ON, See Figure 13	25°C	3.3 V		13.5	Ω	
NO OFF leakage current	$I_{\text{NO(OFF)}}$	$V_{\text{NO}} = 0\text{ to }V_+$, $V_{\text{COM}} = V_+\text{ to }0$, Switch OFF, See Figure 14	25°C	3.6 V			-0.1	0.1
			Full				-1	1
COM OFF leakage current	$I_{\text{COM(OFF)}}$	$V_{\text{COM}} = 0\text{ to }V_+$, $V_{\text{NO}} = V_+\text{ to }0$, Switch OFF, See Figure 14	25°C	3.6 V			-0.1	0.1
			Full				-1	1
NO ON leakage current	$I_{\text{NO(ON)}}$	$V_{\text{NO}} = 0\text{ to }V_+$, $V_{\text{COM}} = V_+\text{ to }0$, Switch ON, See Figure 14	25°C	3.6 V			-0.1	0.1
			Full				-1	1
COM ON leakage current	$I_{\text{COM(ON)}}$	$V_{\text{NO}} = \text{Open}$, $V_{\text{COM}} = 0\text{ to }V_+$, Switch ON, See Figure 14	25°C	3.6 V			-0.1	0.1
			Full				-1	1
Digital Control Inputs (IN1, IN2)⁽²⁾								
Input logic high	V_{IH}		Full		$V_+ \times 0.7$		5.5	V
Input logic low	V_{IL}		Full		0		$V_+ \times 0.3$	V
Input leakage current	$I_{\text{IH}}, I_{\text{IL}}$	$V_{\text{I}} = 5.5\text{ V or }0$	25°C	3.6 V			-1	0.1
			Full				1	

(1) The algebraic convention, whereby the most negative value is a minimum and the most positive value is a maximum

(2) All unused digital inputs of the device must be held at V_+ or GND to ensure proper device operation. Refer to the TI application report, *Implications of Slow or Floating CMOS Inputs*, literature number SCBA004.

Electrical Characteristics for 3.3-V Supply⁽¹⁾ (continued)
 $V_+ = 3\text{ V to }3.6\text{ V}$, $T_A = -40^\circ\text{C to }85^\circ\text{C}$ (unless otherwise noted)

PARAMETER	SYMBOL	TEST CONDITIONS	T_A	V_+	MIN	TYP	MAX	UNIT
Dynamic								
Turn-on time	t_{ON}	$V_{NO} = V_+$ or GND, $R_L = 500\ \Omega$,	$C_L = 50\text{ pF}$, See Figure 16	25°C	3.3 V	2	9.5	ns
				Full	3 V to 3.6 V	2	11	
Turn-off time	t_{OFF}	$V_{NO} = V_+$ or GND, $R_L = 500\ \Omega$,	$C_L = 50\text{ pF}$, See Figure 16	25°C	3.3 V	1.3	5.1	ns
				Full	3 V to 3.6 V	1.5	5.5	
Break-before-make time	t_{BBM}	$V_{NO} = V_+$, $R_L = 50\ \Omega$,	$C_L = 50\text{ pF}$, See Figure 17	25°C	3.3 V	0.5		ns
				Full	3 V to 3.6 V	0.5		
Charge injection	Q_C	$V_{GEN} = 0$, $C_L = 0.1\text{ nF}$,	25°C	3.3 V		1.75		pC
NO OFF capacitance	$C_{NO(OFF)}$	$V_{NO} = V_+$ or GND, Switch OFF,	25°C	3.3 V		4.5		pF
COM OFF capacitance	$C_{COM(OFF)}$	$V_{NO} = V_+$ or GND, Switch OFF,	25°C	3.3 V		10.5		pF
NO ON capacitance	$C_{NO(ON)}$	$V_{NO} = V_+$ or GND, Switch ON,	25°C	3.3 V		17		pF
COM ON capacitance	$C_{COM(ON)}$	$V_{COM} = V_+$ or GND, Switch ON,	25°C	3.3 V		17		pF
Digital input capacitance	C_I	$V_I = V_+$ or GND,	25°C	3.3 V		3		pF
Bandwidth	BW	$R_L = 50\ \Omega$, Switch ON,	25°C	3 V to 3.6 V		327		MHz
OFF isolation	O_{ISO}	$R_L = 50\ \Omega$, $f = 10\text{ MHz}$,	25°C	3 V to 3.6 V		-82		dB
Crosstalk	X_{TALK}	$R_L = 50\ \Omega$, $f = 10\text{ MHz}$,	25°C	3 V to 3.6 V		-62		dB
Supply								
Positive supply current	I_+	$V_I = V_+$ or GND, Switch ON or OFF	25°C	3.6 V			1	μA
			Full				10	

7.7 Electrical Characteristics for 2.5-V Supply⁽¹⁾

$V_+ = 2.3 \text{ V to } 2.7 \text{ V}$, $T_A = -40^\circ\text{C to } 85^\circ\text{C}$ (unless otherwise noted)

PARAMETER	SYMBOL	TEST CONDITIONS		T_A	V_+	MIN	TYP	MAX	UNIT
Analog Switch									
Analog signal range	V_{COM}, V_{NO}					0		V_+	V
Peak ON resistance	r_{peak}	$0 \leq V_{NO} \leq V_+$, $I_{COM} = -8 \text{ mA}$	Switch ON, See Figure 13	Full	2.3 V			50	Ω
ON-state resistance	r_{on}	$V_{NO} = 0 \text{ V}$, $I_{COM} = 8 \text{ mA}$	Switch ON, See Figure 13	25°C	2.3 V	8		12	Ω
				Full				12	
		25°C		11		30			
		Full				30			
ON-state resistance match between channels	Δr_{on}	$V_{NO} = 1.8 \text{ V}$, $I_{COM} = -8 \text{ mA}$	Switch ON, See Figure 13	25°C	2.3 V	0.3			Ω
ON-state resistance flatness	$r_{on(Flat)}$	$0 \leq V_{NO} \leq V_+$, $I_{COM} = -8 \text{ mA}$	Switch ON, See Figure 13	25°C	2.5 V	39			Ω
NO OFF leakage current	$I_{NO(OFF)}$	$V_{NO} = 0 \text{ to } V_+$, $V_{COM} = V_+ \text{ to } 0$	Switch OFF, See Figure 14	25°C	2.7 V	-0.1		0.1	μA
				Full		-1		1	
COM OFF leakage current	$I_{COM(OFF)}$	$V_{COM} = 0 \text{ to } V_+$, $V_{NO} = V_+ \text{ to } 0$	Switch OFF, See Figure 14	25°C	2.7 V	-0.1		0.1	μA
				Full		-1		1	
NO ON leakage current	$I_{NO(ON)}$	$V_{NO} = 0 \text{ to } V_+$, $V_{COM} = V_+ \text{ to } 0$	Switch ON, See Figure 14	25°C	2.7 V	-0.1		0.1	μA
				Full		-1		1	
COM ON leakage current	$I_{COM(ON)}$	$V_{NO} = \text{Open}$, $V_{COM} = 0 \text{ to } V_+$	Switch ON, See Figure 14	25°C	2.7 V	-0.1		0.1	μA
				Full		-1		1	
Digital Control Inputs (IN1, IN2)⁽²⁾									
Input logic high	V_{IH}			Full		$V_+ \times 0.75$		5.5	V
Input logic low	V_{IL}			Full		0	$V_+ \times 0.25$		V
Input leakage current	I_{IH}, I_{IL}	$V_I = 5.5 \text{ V or } 0$		25°C	2.7 V			0.1	μA
				Full				1	

- (1) The algebraic convention, whereby the most negative value is a minimum and the most positive value is a maximum
- (2) All unused digital inputs of the device must be held at V_+ or GND to ensure proper device operation. Refer to the TI application report, *Implications of Slow or Floating CMOS Inputs*, literature number SCBA004.

Electrical Characteristics for 2.5-V Supply⁽¹⁾ (continued)
 $V_+ = 2.3\text{ V to }2.7\text{ V}$, $T_A = -40^\circ\text{C to }85^\circ\text{C}$ (unless otherwise noted)

PARAMETER	SYMBOL	TEST CONDITIONS	T_A	V_+	MIN	TYP	MAX	UNIT
Dynamic								
Turn-on time	t_{ON}	$V_{NO} = V_+$ or GND, $R_L = 500\ \Omega$,	$C_L = 50\text{ pF}$, See Figure 16	25°C	2.5 V	3	15	ns
				Full	2.3 V to 2.7 V	3	16.5	
Turn-off time	t_{OFF}	$V_{NO} = V_+$ or GND, $R_L = 500\ \Omega$,	$C_L = 50\text{ pF}$, See Figure 16	25°C	2.5 V	2	7.2	ns
				Full	2.3 V to 2.7 V	2	7.8	
Break-before-make time	t_{BBM}	$V_{NO} = V_+$, $R_L = 50\ \Omega$,	$C_L = 50\text{ pF}$, See Figure 17	25°C	2.5 V	0.5		ns
				Full	2.3 V to 2.7 V	0.5		
Charge injection	Q_C	$V_{GEN} = 0$, $C_L = 0.1\text{ nF}$,	See Figure 21	25°C	2.5 V	1.15		pC
NO OFF capacitance	$C_{NO(OFF)}$	$V_{NO} = V_+$ or GND, Switch OFF,	See Figure 15	25°C	2.5 V	4.5		pF
COM OFF capacitance	$C_{COM(OFF)}$	$V_{NO} = V_+$ or GND, Switch OFF,	See Figure 15	25°C	2.5 V	10.5		pF
NO ON capacitance	$C_{NO(ON)}$	$V_{NO} = V_+$ or GND, Switch ON,	See Figure 15	25°C	2.5 V	17		pF
COM ON capacitance	$C_{COM(ON)}$	$V_{COM} = V_+$ or GND, Switch ON,	See Figure 15	25°C	2.5 V	17		pF
Digital input capacitance	C_I	$V_I = V_+$ or GND,	See Figure 15	25°C	2.5 V	3		pF
Bandwidth	BW	$R_L = 50\ \Omega$, Switch ON,	See Figure 18	25°C	2.3 V to 2.7 V	320		MHz
OFF isolation	O_{ISO}	$R_L = 50\ \Omega$, $f = 10\text{ MHz}$,	Switch OFF, See Figure 19	25°C	2.3 V to 2.7 V	-81		dB
Crosstalk	X_{TALK}	$R_L = 50\ \Omega$, $f = 10\text{ MHz}$,	Switch ON, See Figure 20	25°C	2.3 V to 2.7 V	-61		dB
Supply								
Positive supply current	I_+	$V_I = V_+$ or GND,	Switch ON or OFF	25°C	2.7 V		1	μA
				Full			10	

7.8 Electrical Characteristics for 1.8-V Supply⁽¹⁾

$V_+ = 1.65\text{ V to }1.95\text{ V}$, $T_A = -40^\circ\text{C to }85^\circ\text{C}$ (unless otherwise noted)

PARAMETER	SYMBOL	TEST CONDITIONS	T_A	V_+	MIN	TYP	MAX	UNIT
Analog Switch								
Analog signal range	V_{COM}, V_{NO}				0		V_+	V
Peak ON resistance	r_{peak}	$0 \leq V_{NO} \leq V_+$, $I_{COM} = -4\text{ mA}$, Switch ON, See Figure 13	Full	1.65 V			150	Ω
ON-state resistance	r_{on}	$V_{NO} = 0\text{ V}$, $I_{COM} = 4\text{ mA}$	25°C	1.65 V			10	Ω
			Full				20	
		$V_{NO} = 1.8\text{ V}$, $I_{COM} = -4\text{ mA}$	25°C				17	
			Full				50	
ON-state resistance match between channels	Δr_{on}	$V_{NO} = 1.15\text{ V}$, $I_{COM} = -4\text{ mA}$, Switch ON, See Figure 13	25°C	1.65 V		0.3	Ω	
ON-state resistance flatness	$r_{on(flat)}$	$0 \leq V_{NO} \leq V_+$, $I_{COM} = -4\text{ mA}$, Switch ON, See Figure 13	25°C	1.8 V		140	Ω	
NO OFF leakage current	$I_{NO(OFF)}$	$V_{NO} = 0\text{ to }V_+$, $V_{COM} = V_+\text{ to }0$, Switch OFF, See Figure 14	25°C	1.95 V	-0.1		0.1	μA
			Full		-1	1		
COM OFF leakage current	$I_{COM(OFF)}$	$V_{COM} = 0\text{ to }V_+$, $V_{NO} = V_+\text{ to }0$, Switch OFF, See Figure 14	25°C	1.95 V	-0.1		0.1	μA
			Full		-1	1		
NO ON leakage current	$I_{NO(ON)}$	$V_{NO} = 0\text{ to }V_+$, $V_{COM} = V_+\text{ to }0$, Switch ON, See Figure 14	25°C	1.95 V	-0.1		0.1	μA
			Full		-1	1		
COM ON leakage current	$I_{COM(ON)}$	$V_{NO} = \text{Open}$, $V_{COM} = 0\text{ to }V_+$, Switch ON, See Figure 14	25°C	1.95 V	-0.1		0.1	μA
			Full		-1	1		
Digital Control Inputs (IN1, IN2)⁽²⁾								
Input logic high	V_{IH}		Full		$V_+ \times 0.75$		5.5	V
Input logic low	V_{IL}		Full		0		$V_+ \times 0.25$	V
Input leakage current	I_{IH}, I_{IL}	$V_I = 5.5\text{ V or }0$	25°C	1.95 V			0.1	μA
			Full			1		

- (1) The algebraic convention, whereby the most negative value is a minimum and the most positive value is a maximum
- (2) All unused digital inputs of the device must be held at V_+ or GND to ensure proper device operation. Refer to the TI application report, *Implications of Slow or Floating CMOS Inputs*, literature number SCBA004.

Electrical Characteristics for 1.8-V Supply⁽¹⁾ (continued)
 $V_+ = 1.65\text{ V to }1.95\text{ V}$, $T_A = -40^\circ\text{C to }85^\circ\text{C}$ (unless otherwise noted)

PARAMETER	SYMBOL	TEST CONDITIONS	T_A	V_+	MIN	TYP	MAX	UNIT
Dynamic								
Turn-on time	t_{ON}	$V_{NO} = V_+$ or GND, $R_L = 500\ \Omega$, $C_L = 50\text{ pF}$, See Figure 16	25°C	1.8 V	5		32	ns
			Full	1.65 V to 1.95 V	5		34	
Turn-off time	t_{OFF}	$V_{NO} = V_+$ or GND, $R_L = 500\ \Omega$, $C_L = 50\text{ pF}$, See Figure 16	25°C	1.8 V	3		14	ns
			Full	1.65 V to 1.95 V	3		14.5	
Break-before-make time	t_{BBM}	$V_{NO} = V_+$, $R_L = 50\ \Omega$, $C_L = 50\text{ pF}$, See Figure 17	25°C	1.8 V	0.5			ns
			Full	1.65 V to 1.95 V	0.5			
Charge injection	Q_C	$V_{GEN} = 0$, $C_L = 0.1\text{ nF}$, See Figure 21	25°C	1.8 V		0.3		pC
NO OFF capacitance	$C_{NO(OFF)}$	$V_{NO} = V_+$ or GND, Switch OFF, See Figure 15	25°C	1.8 V		4.5		pF
COM OFF capacitance	$C_{COM(OFF)}$	$V_{NO} = V_+$ or GND, Switch OFF, See Figure 15	25°C	1.8 V		10.5		pF
NO ON capacitance	$C_{NO(ON)}$	$V_{NO} = V_+$ or GND, Switch ON, See Figure 15	25°C	1.8 V		17		pF
COM ON capacitance	$C_{COM(ON)}$	$V_{COM} = V_+$ or GND, Switch ON, See Figure 15	25°C	1.8 V		17		pF
Digital input capacitance	C_I	$V_I = V_+$ or GND, See Figure 15	25°C	1.8 V		3		pF
Bandwidth	BW	$R_L = 50\ \Omega$, Switch ON, See Figure 18	25°C	1.65 V to 1.95 V		341		MHz
OFF isolation	O_{ISO}	$R_L = 50\ \Omega$, $f = 10\text{ MHz}$, Switch OFF, See Figure 19	25°C	1.65 V to 1.95 V		-81		dB
Crosstalk	X_{TALK}	$R_L = 50\ \Omega$, $f = 10\text{ MHz}$, Switch ON, See Figure 20	25°C	1.65 V to 1.95 V		-61		dB
Supply								
Positive supply current	I_+	$V_I = V_+$ or GND, Switch ON or OFF	25°C	1.95 V			1	μA
			Full				10	

7.9 Typical Characteristics

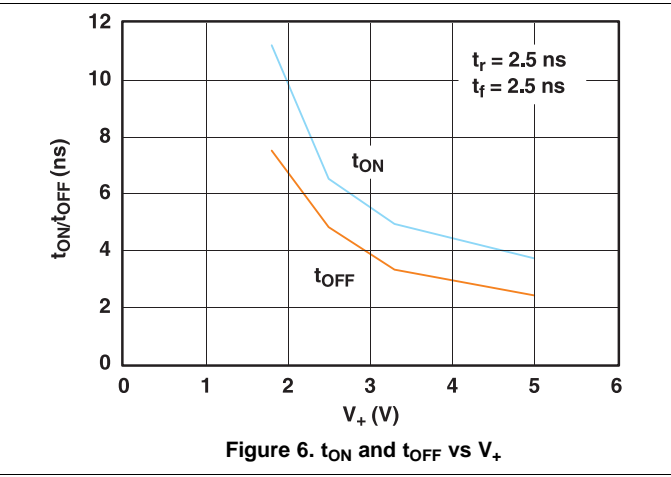
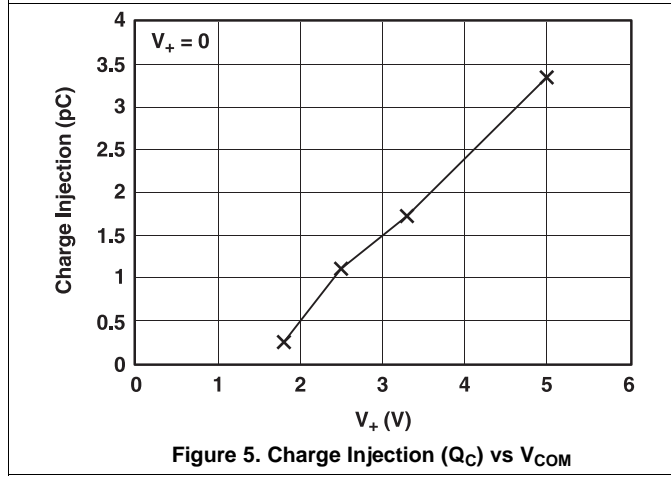
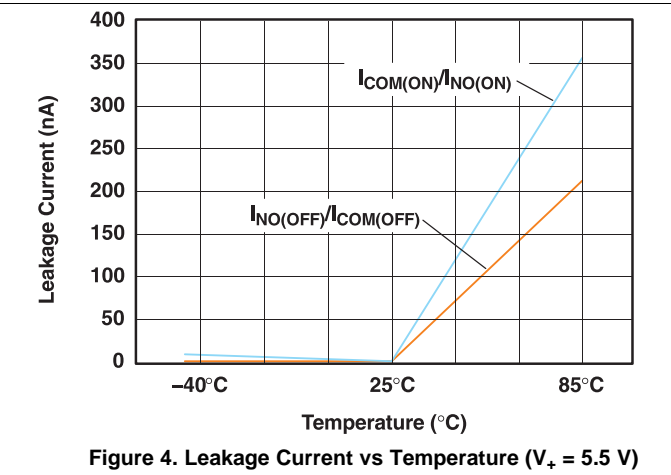
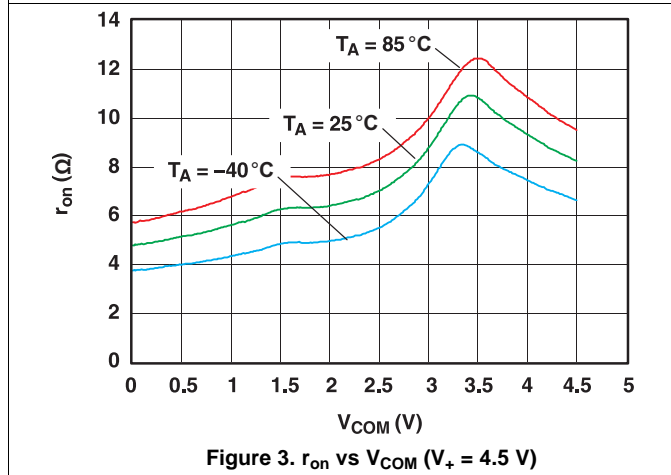
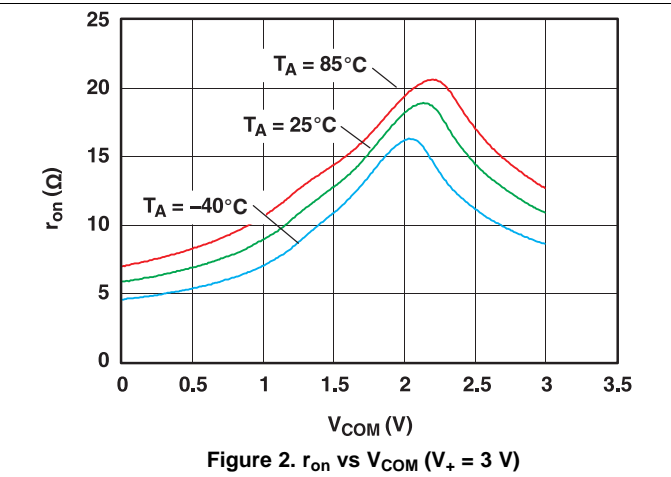
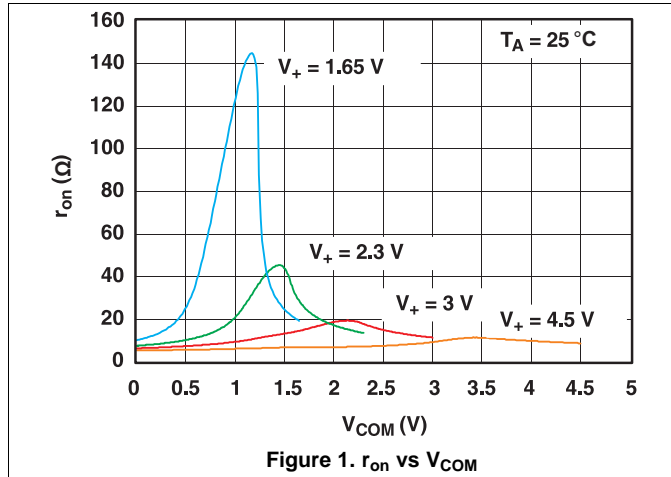

Typical Characteristics (continued)

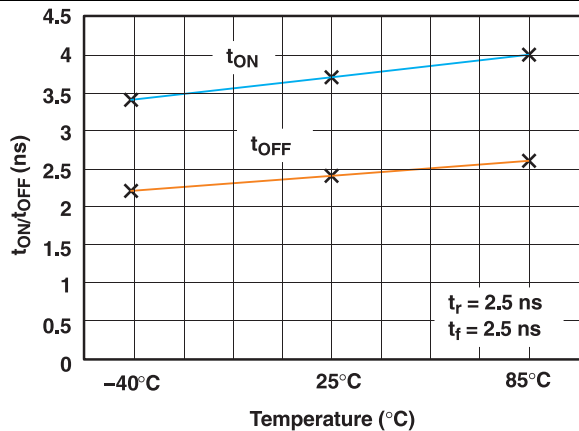

Figure 7. t_{ON} and t_{OFF} vs Temperature (V₊ = 5 V)

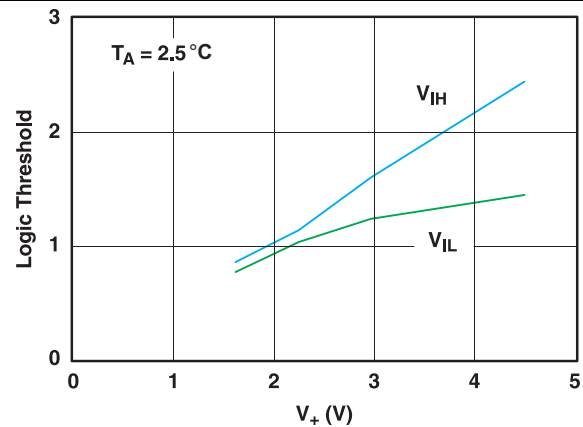

Figure 8. Logic-Level Threshold vs V₊

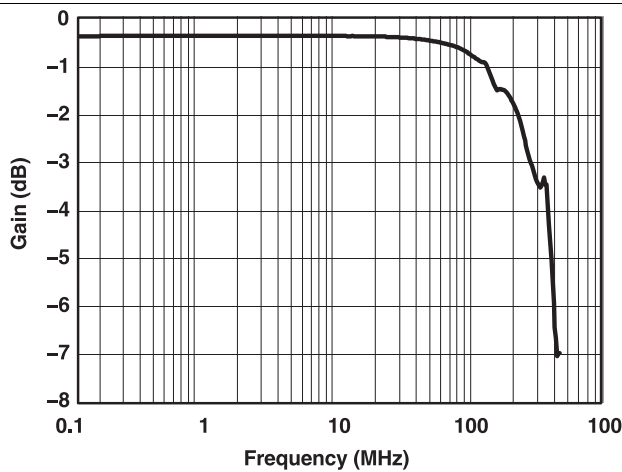

Figure 9. Frequency Response (V₊ = 3 V)

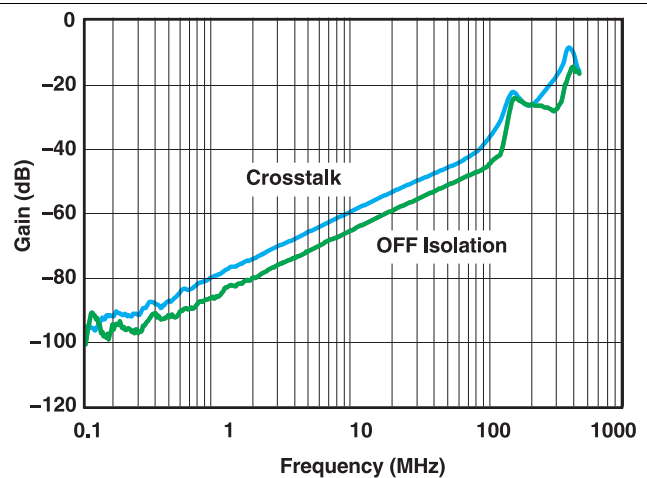

Figure 10. OFF Isolation and Crosstalk vs Frequency (V₊ = 3 V)

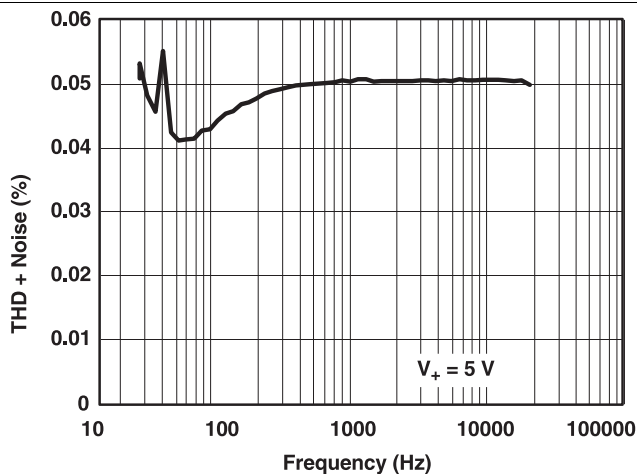

Figure 11. Total Harmonic Distortion vs Frequency (V₊ = 5 V)

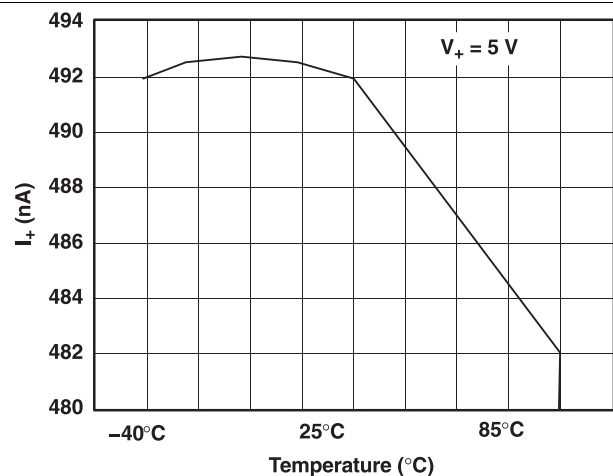

Figure 12. Power-Supply Current vs Temperature (V₊ = 5 V)

8 Parameter Measurement Information

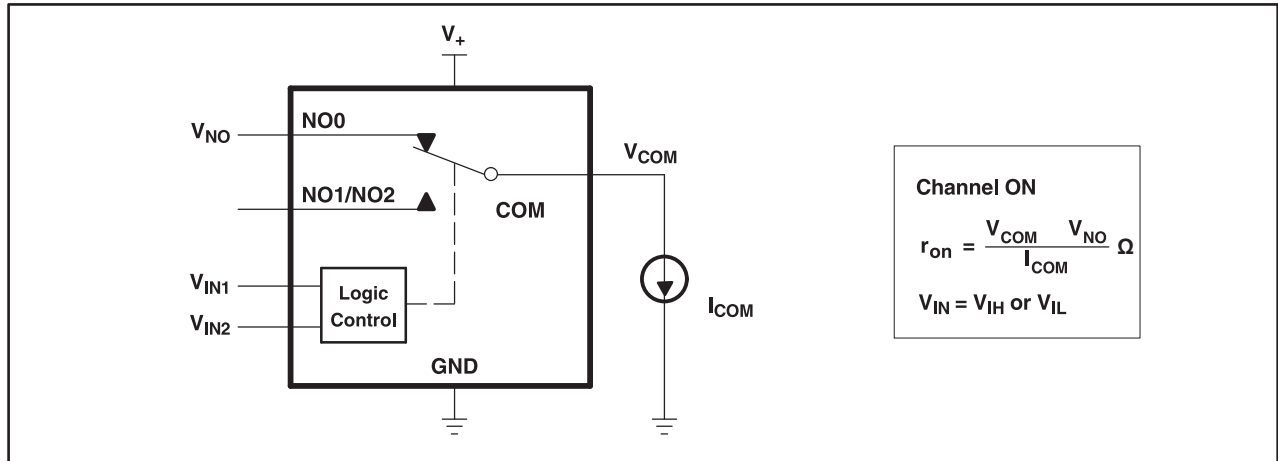

Figure 13. ON-State Resistance (r_{on})

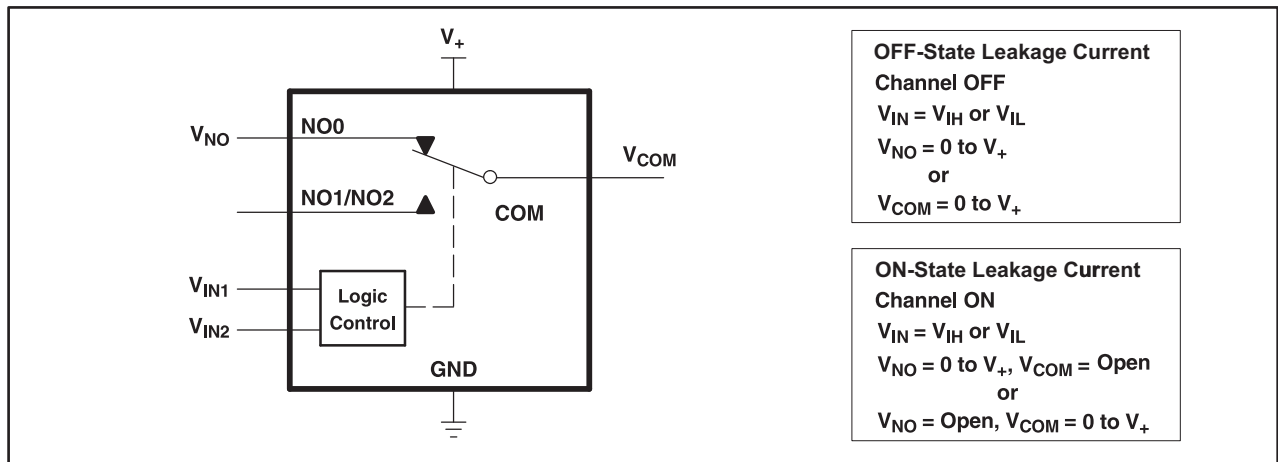

Figure 14. ON- and OFF-State Leakage Current ($I_{COM(ON)}$, $I_{COM(OFF)}$, $I_{NO(ON)}$, $I_{NO(OFF)}$)

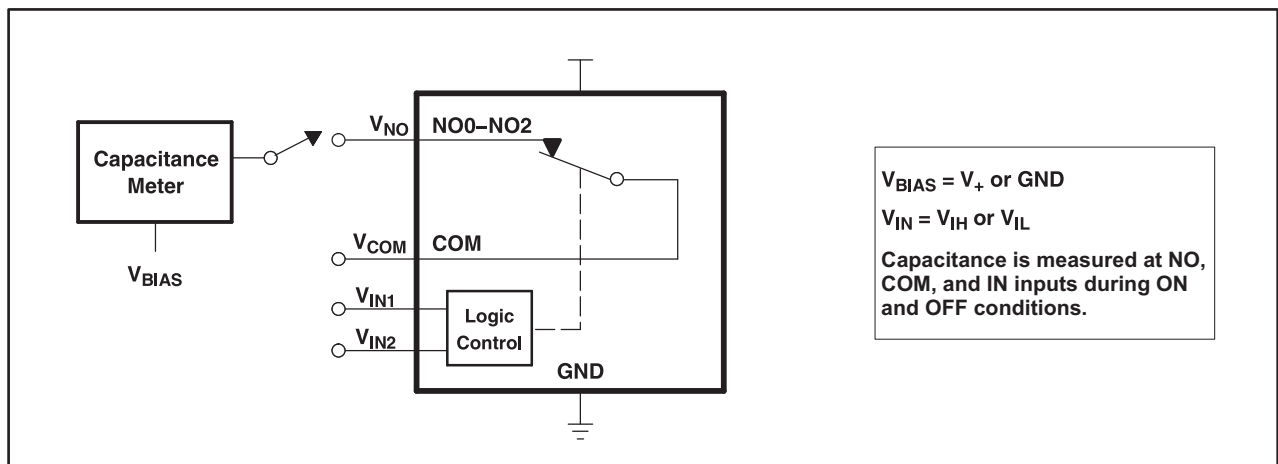
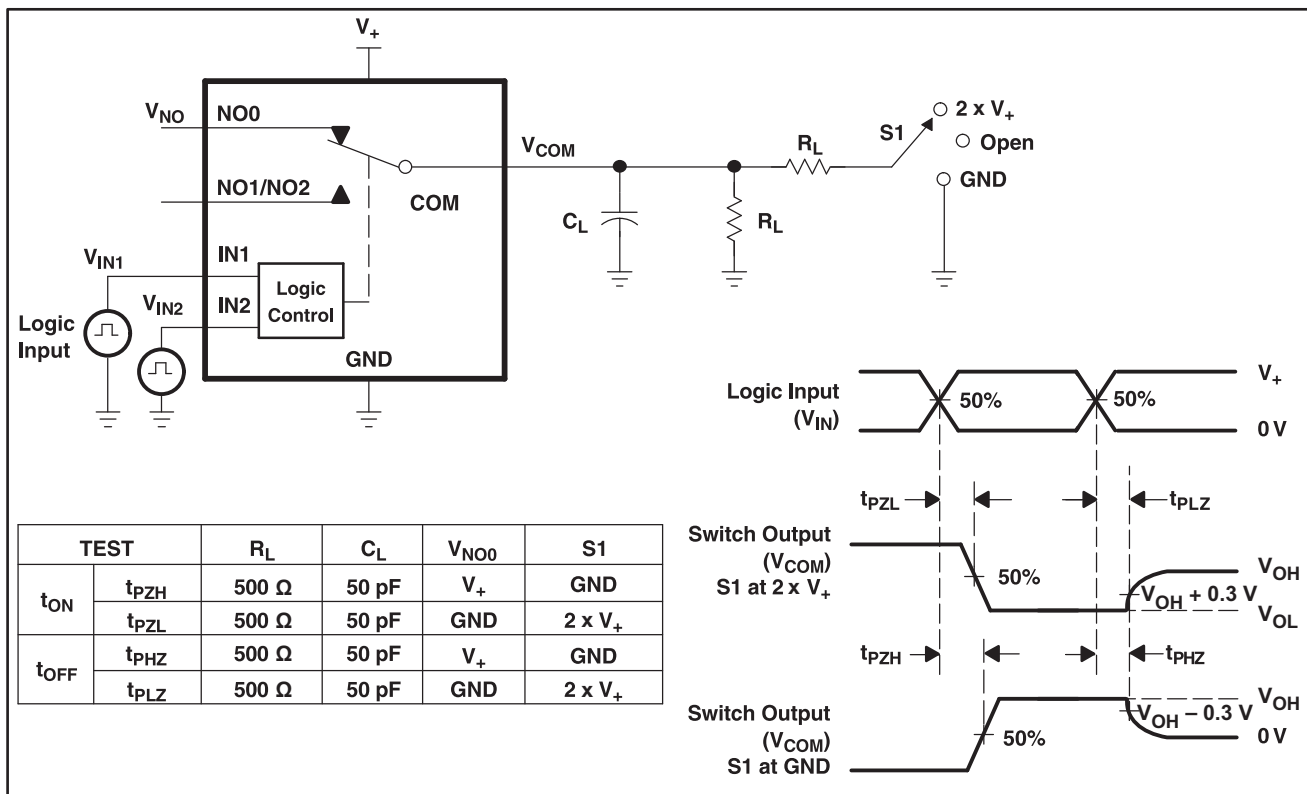

Figure 15. Capacitance (C_I , $C_{COM(ON)}$, $C_{NO(OFF)}$, $C_{COM(OFF)}$, $C_{NO(ON)}$)

Parameter Measurement Information (continued)



- A. All input pulses are supplied by generators having the following characteristics: PRR \leq 10 MHz, $Z_O = 50 \Omega$, $t_r < 5$ ns, $t_f < 5$ ns.
- B. C_L includes probe and jig capacitance.

Figure 16. Turn-On (t_{ON}) and Turn-Off Time (t_{OFF})

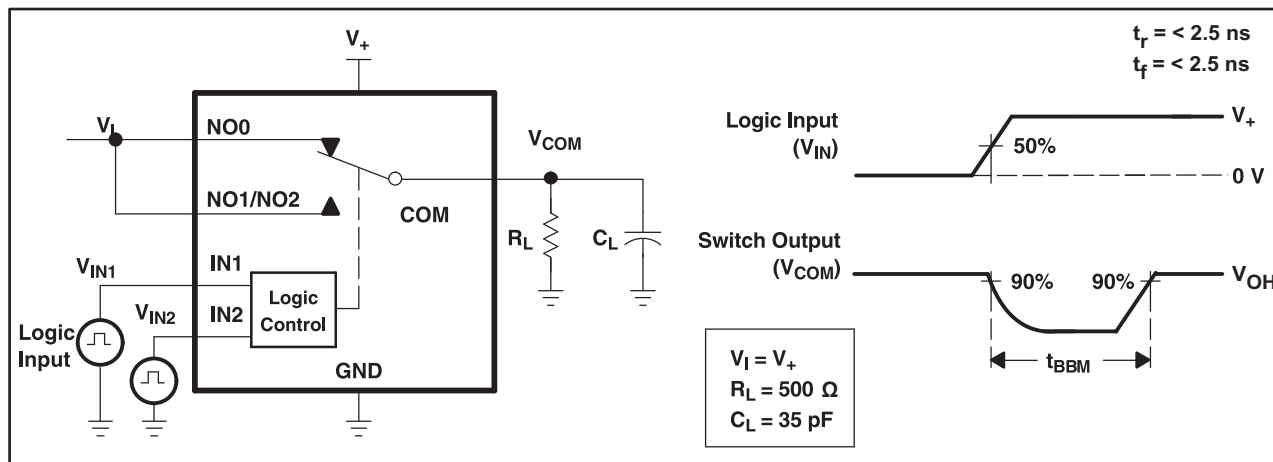

- A. All input pulses are supplied by generators having the following characteristics: PRR \leq 10 MHz, $Z_O = 50 \Omega$, $t_r < 5$ ns, $t_f < 5$ ns.
- B. C_L includes probe and jig capacitance.

Figure 17. Break-Before-Make Time (t_{BBM})

Parameter Measurement Information (continued)

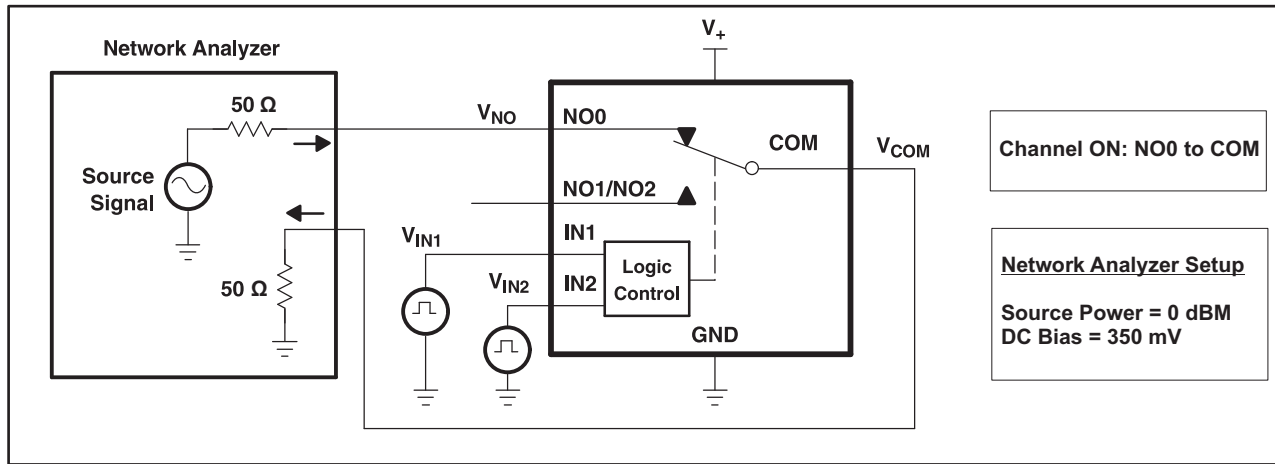

Figure 18. Bandwidth (BW)

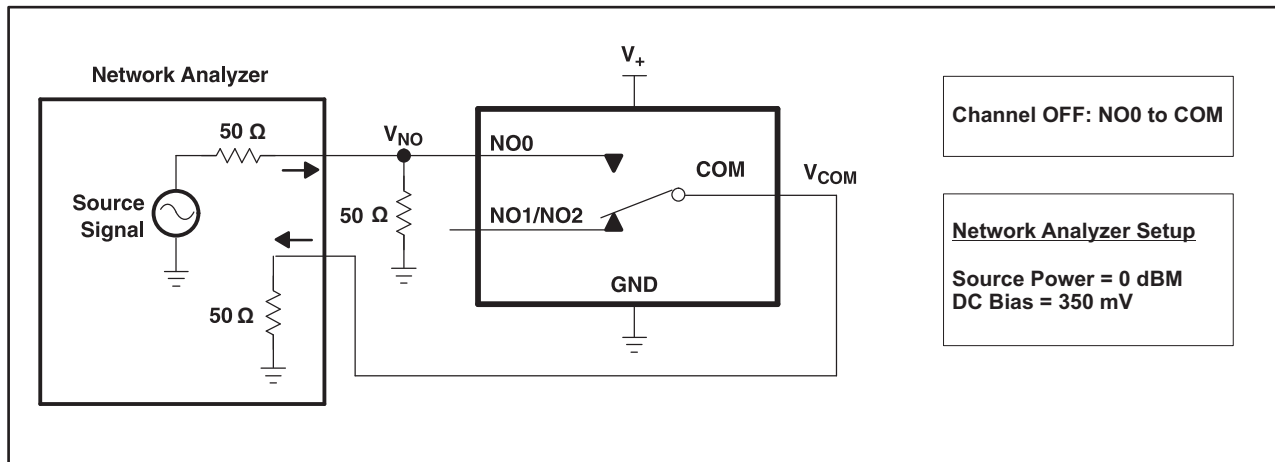

Figure 19. OFF Isolation (O_{ISO})

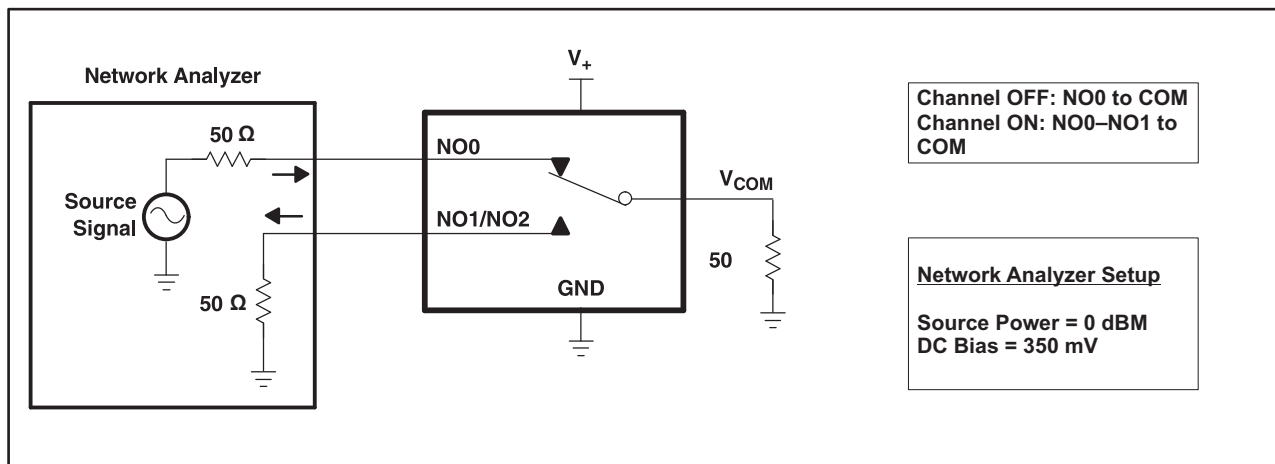
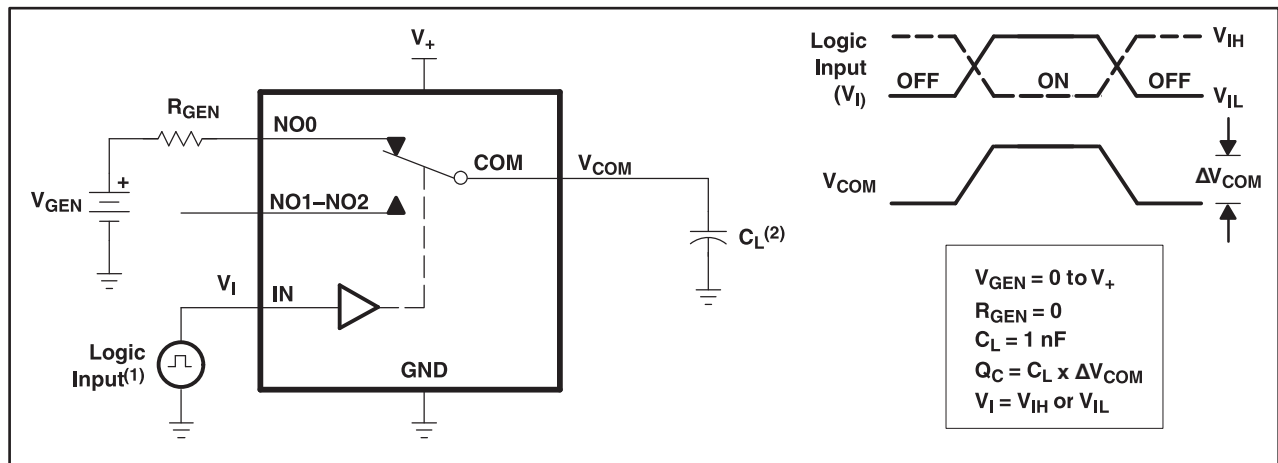

Figure 20. Crosstalk (X_{TALK})

Parameter Measurement Information (continued)



- A. All input pulses are supplied by generators having the following characteristics: PRR \leq 10 MHz, $Z_0 = 50 \Omega$, $t_r < 5$ ns, $t_f < 5$ ns.
- B. C_L includes probe and jig capacitance.

Figure 21. Charge Injection (Q_C)

9 Detailed Description

9.1 Overview

The TS5A3357 is a bidirectional, single-channel, 3:1 analog switch that is designed to operate from 1.65 V to 5.5 V. This device provides a signal switching solution while maintaining excellent signal integrity, which makes the TS5A3357 suitable for a wide range of applications in various markets including personal electronics, portable instrumentation, and test and measurement equipment. The device maintains the signal integrity by its low ON-state resistance, excellent ON-state resistance matching, and total harmonic distortion (THD) performance. To prevent signal distortion during the transferring of a signal from one channel to another, the TS5A3357 device also has a specified break-before-make feature.

9.2 Functional Block Diagram

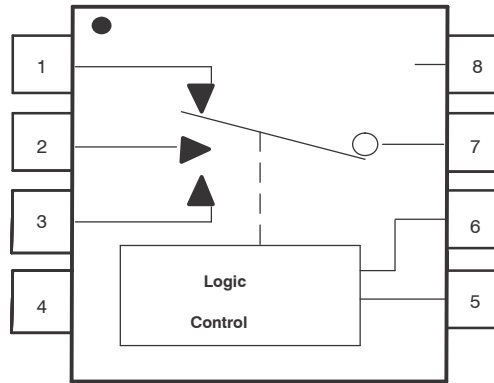

9.3 Feature Description

Break-before-make

Break-before-make is a safety feature that prevents two inputs from connecting when the TS5A3357 is switching. The TS5A3357 COM pin first breaks from the on-state switch before making the connection with the next on-state switch. The time delay between the break and the make is known as a break-before-make delay t_{BBM} .

9.4 Device Functional Modes

The digital control pins IN1 and IN2 determine the state of the connection between the COM and NO pins based on the truth table below.

Table 2. Function Table

IN1	IN2	COM TO NO0	COM TO NO1	COM TO NO2
L	L	OFF	OFF	OFF
H	L	ON	OFF	OFF
L	H	OFF	ON	OFF
H	H	OFF	OFF	ON

10 Application and Implementation

NOTE

Information in the following applications sections is not part of the TI component specification, and TI does not warrant its accuracy or completeness. TI's customers are responsible for determining suitability of components for their purposes. Customers should validate and test their design implementation to confirm system functionality.

10.1 Application Information

10.2 Typical Application

The TS5A3357 switch is bidirectional, so the NO and COM pins can be used as either inputs or outputs. This switch is typically used when there is only one signal path that needs to be able to communicate to 3 different signal paths.

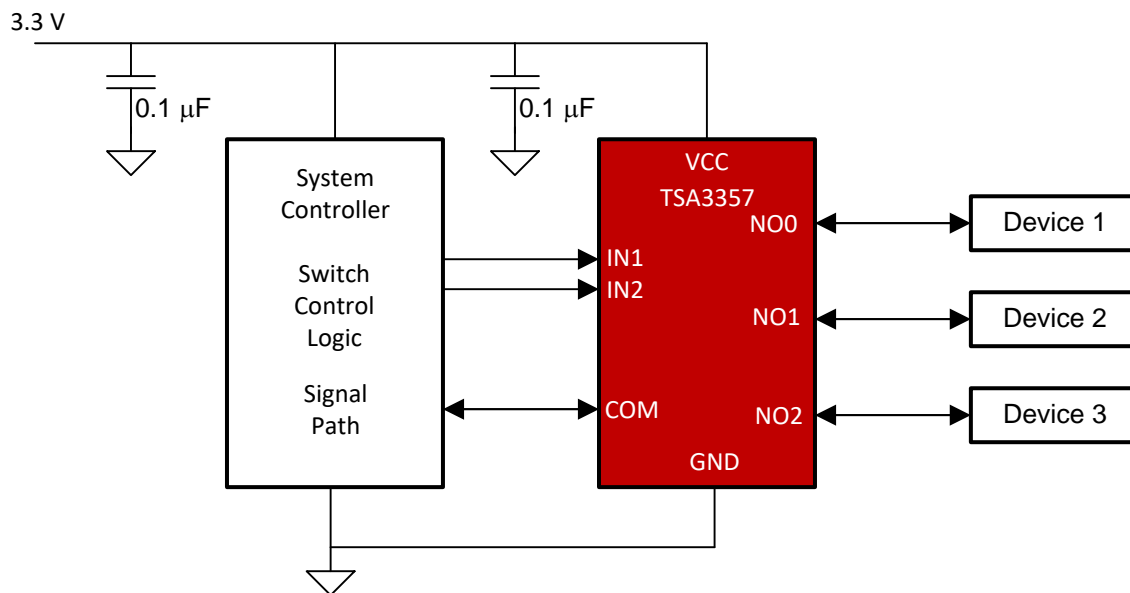

Figure 22. Typical Application Schematic

10.2.1 Design Requirements

The TS5A3357 device can be properly operated without any external components. However, TI recommends connecting unused pins to ground through a 50-Ω resistor to prevent signal reflections back into the device. TI also recommends pulling up the digital control pins (IN1 and IN2) to VCC or pulling down to GND to avoid undesired switch positions that could result from the floating pin.

10.2.2 Detailed Design Procedure

Select the appropriate supply voltage to cover the entire voltage swing of the signal passing through the switch because the TS5A3357 input and output signal swing through NO and COM are dependent on the supply voltage V_+ . For example, if the desired signal level to pass through the switch is 5 V, VCC must be greater than or equal to 5 V. $V_+ = 3.3$ V would not be valid for passing a 5-V signal since the Analog signal voltage cannot exceed the supply.

Typical Application (continued)

10.2.3 Application Curves

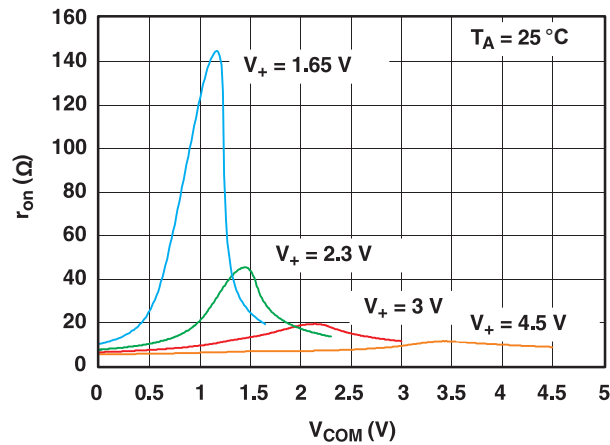

Figure 23. r_{on} vs V_{COM}

11 Power Supply Recommendations

TI recommends proper power-supply sequencing for all CMOS devices. Do not exceed the absolute maximum ratings, because stresses beyond the listed ratings can cause permanent damage to the device. Always sequence V_+ on first, followed by NO or COM. Although it is not required, power-supply bypassing improves noise margin and prevents switching noise propagation from the V_+ supply to other components. A 0.1- μ F capacitor, connected from VCC to GND, is adequate for most applications.

12 Layout

12.1 Layout Guidelines

TI recommends following common printed-circuit board layout guidelines to ensure reliability of the device. Bypass capacitors should be used on power supplies. Short trace lengths should be used to avoid excessive loading.

12.2 Layout Example

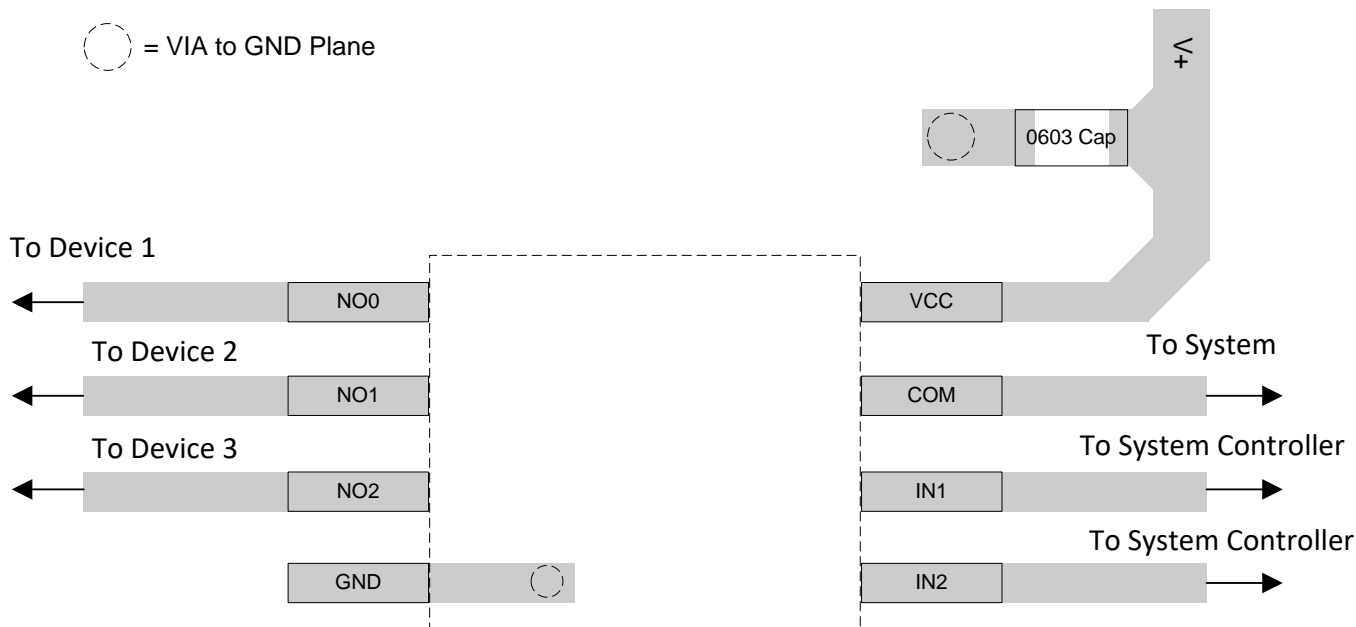

Figure 24. Example Layout

13 Device and Documentation Support

13.1 Device Support

13.2 Documentation Support

13.3 Receiving Notification of Documentation Updates

To receive notification of documentation updates, navigate to the device product folder on ti.com. In the upper right corner, click on *Alert me* to register and receive a weekly digest of any product information that has changed. For change details, review the revision history included in any revised document.

13.4 Community Resources

The following links connect to TI community resources. Linked contents are provided "AS IS" by the respective contributors. They do not constitute TI specifications and do not necessarily reflect TI's views; see TI's [Terms of Use](#).

TI E2E™ Online Community *TI's Engineer-to-Engineer (E2E) Community*. Created to foster collaboration among engineers. At e2e.ti.com, you can ask questions, share knowledge, explore ideas and help solve problems with fellow engineers.

Design Support *TI's Design Support* Quickly find helpful E2E forums along with design support tools and contact information for technical support.

13.5 Trademarks

E2E is a trademark of Texas Instruments.

13.6 Electrostatic Discharge Caution



This integrated circuit can be damaged by ESD. Texas Instruments recommends that all integrated circuits be handled with appropriate precautions. Failure to observe proper handling and installation procedures can cause damage.

ESD damage can range from subtle performance degradation to complete device failure. Precision integrated circuits may be more susceptible to damage because very small parametric changes could cause the device not to meet its published specifications.

13.7 Glossary

[SLYZ022](#) — *TI Glossary*.

This glossary lists and explains terms, acronyms, and definitions.

14 Mechanical, Packaging, and Orderable Information

The following pages include mechanical, packaging, and orderable information. This information is the most current data available for the designated devices. This data is subject to change without notice and revision of this document. For browser-based versions of this data sheet, refer to the left-hand navigation.

PACKAGING INFORMATION

Orderable Device	Status (1)	Package Type	Package Drawing	Pins	Package Qty	Eco Plan (2)	Lead finish/ Ball material (6)	MSL Peak Temp (3)	Op Temp (°C)	Device Marking (4/5)	Samples
TS5A3357DCUR	ACTIVE	VSSOP	DCU	8	3000	RoHS & Green	NIPDAU SN	Level-1-260C-UNLIM	-40 to 85	(JA9Q, JA9R)	Samples
TS5A3357DCURG4	ACTIVE	VSSOP	DCU	8	3000	RoHS & Green	NIPDAU	Level-1-260C-UNLIM	-40 to 85	JA9R	Samples
TS5A3357DCUT	LIFEBUY	VSSOP	DCU	8	250	RoHS & Green	NIPDAU SN	Level-1-260C-UNLIM	-40 to 85	(JA9Q, JA9R)	

(1) The marketing status values are defined as follows:

ACTIVE: Product device recommended for new designs.

LIFEBUY: TI has announced that the device will be discontinued, and a lifetime-buy period is in effect.

NRND: Not recommended for new designs. Device is in production to support existing customers, but TI does not recommend using this part in a new design.

PREVIEW: Device has been announced but is not in production. Samples may or may not be available.

OBSELETE: TI has discontinued the production of the device.

(2) **RoHS:** TI defines "RoHS" to mean semiconductor products that are compliant with the current EU RoHS requirements for all 10 RoHS substances, including the requirement that RoHS substance do not exceed 0.1% by weight in homogeneous materials. Where designed to be soldered at high temperatures, "RoHS" products are suitable for use in specified lead-free processes. TI may reference these types of products as "Pb-Free".

RoHS Exempt: TI defines "RoHS Exempt" to mean products that contain lead but are compliant with EU RoHS pursuant to a specific EU RoHS exemption.

Green: TI defines "Green" to mean the content of Chlorine (Cl) and Bromine (Br) based flame retardants meet JS709B low halogen requirements of <=1000ppm threshold. Antimony trioxide based flame retardants must also meet the <=1000ppm threshold requirement.

(3) MSL, Peak Temp. - The Moisture Sensitivity Level rating according to the JEDEC industry standard classifications, and peak solder temperature.

(4) There may be additional marking, which relates to the logo, the lot trace code information, or the environmental category on the device.

(5) Multiple Device Markings will be inside parentheses. Only one Device Marking contained in parentheses and separated by a "~" will appear on a device. If a line is indented then it is a continuation of the previous line and the two combined represent the entire Device Marking for that device.

(6) Lead finish/Ball material - Orderable Devices may have multiple material finish options. Finish options are separated by a vertical ruled line. Lead finish/Ball material values may wrap to two lines if the finish value exceeds the maximum column width.

Important Information and Disclaimer:The information provided on this page represents TI's knowledge and belief as of the date that it is provided. TI bases its knowledge and belief on information provided by third parties, and makes no representation or warranty as to the accuracy of such information. Efforts are underway to better integrate information from third parties. TI has taken and continues to take reasonable steps to provide representative and accurate information but may not have conducted destructive testing or chemical analysis on incoming materials and chemicals. TI and TI suppliers consider certain information to be proprietary, and thus CAS numbers and other limited information may not be available for release.

In no event shall TI's liability arising out of such information exceed the total purchase price of the TI part(s) at issue in this document sold by TI to Customer on an annual basis.

OTHER QUALIFIED VERSIONS OF TS5A3357 :

- Automotive : [TS5A3357-Q1](#)

NOTE: Qualified Version Definitions:

- Automotive - Q100 devices qualified for high-reliability automotive applications targeting zero defects

TAPE AND REEL INFORMATION

QUADRANT ASSIGNMENTS FOR PIN 1 ORIENTATION IN TAPE

*All dimensions are nominal

Device	Package Type	Package Drawing	Pins	SPQ	Reel Diameter (mm)	Reel Width W1 (mm)	A0 (mm)	B0 (mm)	K0 (mm)	P1 (mm)	W (mm)	Pin1 Quadrant
TS5A3357DCUR	VSSOP	DCU	8	3000	178.0	9.0	2.25	3.35	1.05	4.0	8.0	Q3
TS5A3357DCURG4	VSSOP	DCU	8	3000	180.0	8.4	2.25	3.35	1.05	4.0	8.0	Q3
TS5A3357DCUT	VSSOP	DCU	8	250	178.0	9.0	2.25	3.35	1.05	4.0	8.0	Q3

TAPE AND REEL BOX DIMENSIONS

*All dimensions are nominal

Device	Package Type	Package Drawing	Pins	SPQ	Length (mm)	Width (mm)	Height (mm)
TS5A3357DCUR	VSSOP	DCU	8	3000	180.0	180.0	18.0
TS5A3357DCURG4	VSSOP	DCU	8	3000	202.0	201.0	28.0
TS5A3357DCUT	VSSOP	DCU	8	250	180.0	180.0	18.0

EXAMPLE BOARD LAYOUT

DCU0008A

VSSOP - 0.9 mm max height

SMALL OUTLINE PACKAGE

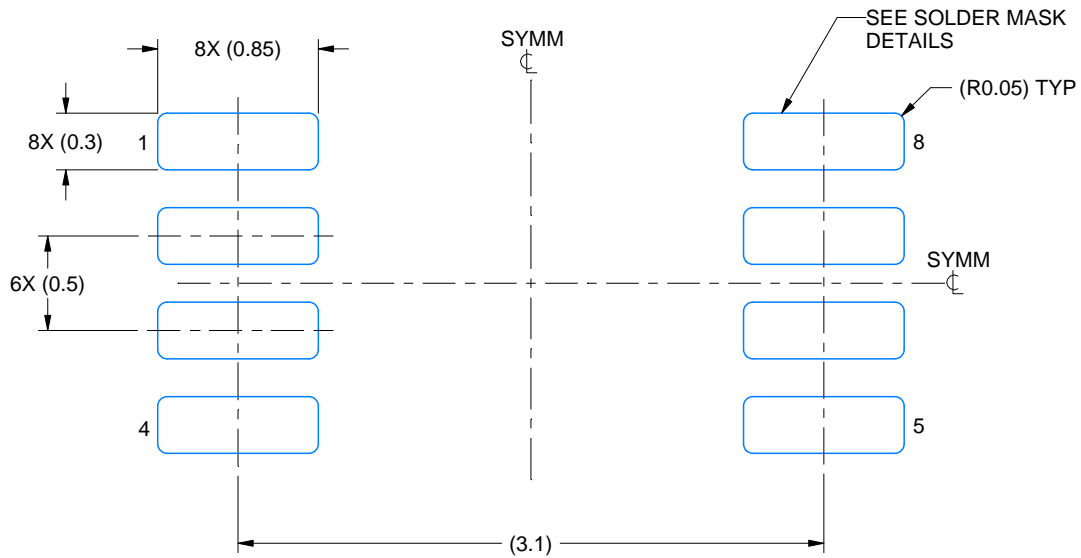

LAND PATTERN EXAMPLE
EXPOSED METAL SHOWN
SCALE: 25X

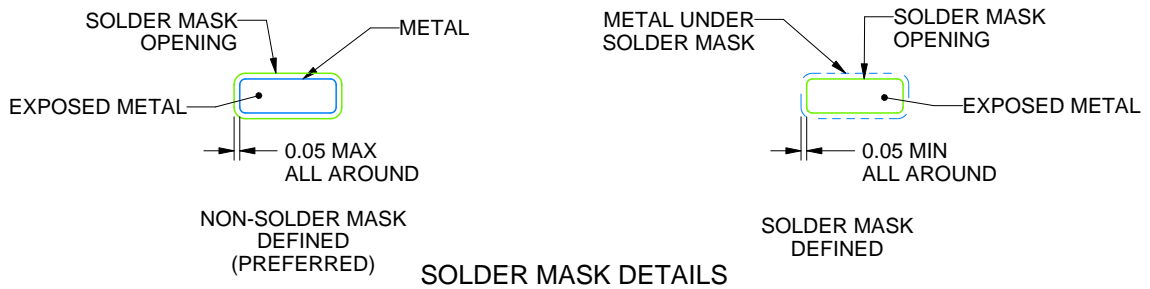

4225266/A 09/2014

NOTES: (continued)

- 5. Publication IPC-7351 may have alternate designs.
- 6. Solder mask tolerances between and around signal pads can vary based on board fabrication site.

EXAMPLE STENCIL DESIGN

DCU0008A

VSSOP - 0.9 mm max height

SMALL OUTLINE PACKAGE

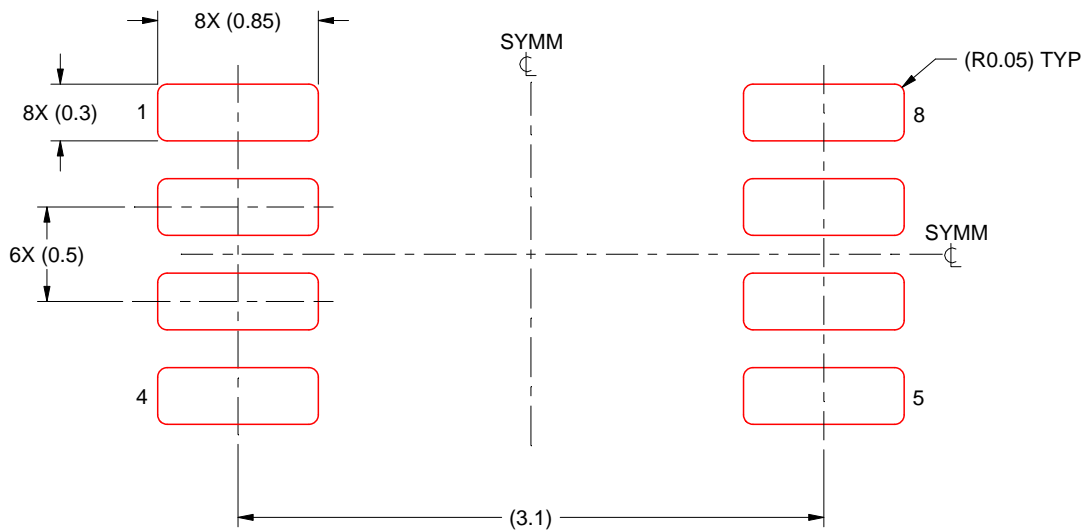

SOLDER PASTE EXAMPLE
BASED ON 0.125 mm THICK STENCIL
SCALE: 25X

4225266/A 09/2014

NOTES: (continued)

7. Laser cutting apertures with trapezoidal walls and rounded corners may offer better paste release. IPC-7525 may have alternate design recommendations.
8. Board assembly site may have different recommendations for stencil design.

IMPORTANT NOTICE AND DISCLAIMER

TI PROVIDES TECHNICAL AND RELIABILITY DATA (INCLUDING DATA SHEETS), DESIGN RESOURCES (INCLUDING REFERENCE DESIGNS), APPLICATION OR OTHER DESIGN ADVICE, WEB TOOLS, SAFETY INFORMATION, AND OTHER RESOURCES "AS IS" AND WITH ALL FAULTS, AND DISCLAIMS ALL WARRANTIES, EXPRESS AND IMPLIED, INCLUDING WITHOUT LIMITATION ANY IMPLIED WARRANTIES OF MERCHANTABILITY, FITNESS FOR A PARTICULAR PURPOSE OR NON-INFRINGEMENT OF THIRD PARTY INTELLECTUAL PROPERTY RIGHTS.

These resources are intended for skilled developers designing with TI products. You are solely responsible for (1) selecting the appropriate TI products for your application, (2) designing, validating and testing your application, and (3) ensuring your application meets applicable standards, and any other safety, security, regulatory or other requirements.

These resources are subject to change without notice. TI grants you permission to use these resources only for development of an application that uses the TI products described in the resource. Other reproduction and display of these resources is prohibited. No license is granted to any other TI intellectual property right or to any third party intellectual property right. TI disclaims responsibility for, and you will fully indemnify TI and its representatives against, any claims, damages, costs, losses, and liabilities arising out of your use of these resources.

TI's products are provided subject to [TI's Terms of Sale](#) or other applicable terms available either on [ti.com](https://www.ti.com) or provided in conjunction with such TI products. TI's provision of these resources does not expand or otherwise alter TI's applicable warranties or warranty disclaimers for TI products.

TI objects to and rejects any additional or different terms you may have proposed.

Mailing Address: Texas Instruments, Post Office Box 655303, Dallas, Texas 75265
Copyright © 2024, Texas Instruments Incorporated

Looking for pricing, stock, or lifecycle information?

Click below to explore more details on WIN SOURCE:

 [View TS5A3357DCURG4 on WIN SOURCE](#)

 [Texas Instruments](#) Information

Optimize Your Supply Chain with WIN SOURCE Solutions

-  Global Sourcing Solution
-  Obsolete Management
-  Cost Control Management
-  Shortage Management
-  Alternative Solution
-  Excess Inventory Management