



**THE DATASHEET OF
TS5A23159RSER**



TS5A23159 1-Ω 2-Channel SPDT Analog Switch 5-V / 3.3-V 2-Channel 2:1 Multiplexer / Demultiplexer

1 Features

- Isolation in Power-Down Mode, $V_{CC} = 0$
- Specified Break-Before-Make Switching
- Low ON-State Resistance (1 Ω)
- Control Inputs are 5.5-V Tolerant
- Low Charge Injection
- Excellent ON-State Resistance Matching
- Low Total Harmonic Distortion (THD)
- Supports Analog and Digital Signals
- 1.65-V to 5.5-V Single-Supply Operation
- Latch-Up Performance Exceeds 100 mA Per JESD 78, Class II
- ESD Performance Tested Per JESD 22
 - 2000-V Human Body Model (A114-B, Class II)
 - 1000-V Charged-Device Model (C101)

2 Applications

- Cell Phones
- PDAs
- Portable Instrumentation
- Audio and Video Signal Routing
- Low-Voltage Data-Acquisition Systems
- Communication Circuits
- Modems
- Hard Drives
- Computer Peripherals
- Wireless Terminals and Peripherals

3 Description

The TS5A23159 is a bidirectional 2-channel single-pole double-throw (SPDT) switch that is designed to operate from 1.65 V to 5.5 V. The device offers low ON-state resistance and excellent ON-state resistance matching with the break-before-make feature which prevents signal distortion during the transferring of a signal from one channel to another. The device has an excellent total harmonic distortion (THD) performance and consumes very low power. These features make this device suitable for a wide variety of portable applications including cell phones, audio devices, and instrumentation.

Device Information⁽¹⁾

PART NUMBER	PACKAGE	BODY SIZE (NOM)
TS5A23159	VSSOP (10)	3.00 mm × 3.00 mm
	UQFN (10)	1.50 mm × 2.00 mm

(1) For all available packages, see the orderable addendum at the end of the data sheet.

Simplified Schematic

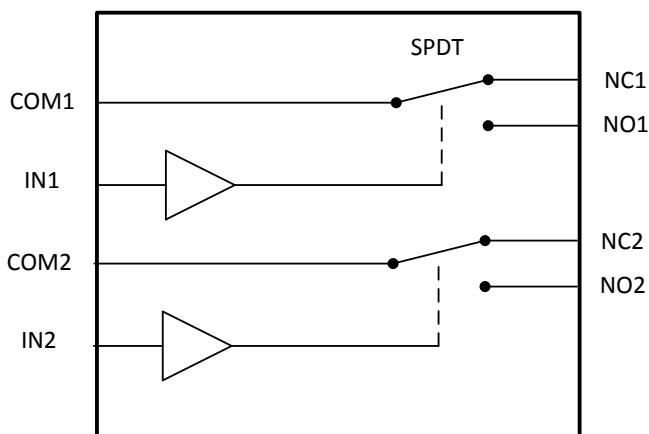

Table of Contents

1 Features 1 2 Applications 1 3 Description 1 4 Revision History 2 5 Pin Configuration and Functions 3 6 Specifications 3 6.1 Absolute Maximum Ratings 3 6.2 ESD Ratings 4 6.3 Recommended Operating Conditions 4 6.4 Thermal Information 4 6.5 Electrical Characteristics for 5-V Supply 5 6.6 Electrical Characteristics for 3.3-V Supply 7 6.7 Electrical Characteristics for 2.5-V Supply 9 6.8 Electrical Characteristics for 1.8-V Supply 11 6.9 Typical Characteristics 13 7 Parameter Measurement Information 16 8 Detailed Description 21	8.1 Overview 21 8.2 Functional Block Diagram 21 8.3 Feature Description 21 8.4 Device Functional Modes 21 9 Application and Implementation 22 9.1 Application Information 22 9.2 Typical Application 22 10 Power Supply Recommendations 23 11 Layout 24 11.1 Layout Guidelines 24 11.2 Layout Example 24 12 Device and Documentation Support 25 12.1 Trademarks 25 12.2 Electrostatic Discharge Caution 25 12.3 Glossary 25 13 Mechanical, Packaging, and Orderable Information 25
--	--

4 Revision History

NOTE: Page numbers for previous revisions may differ from page numbers in the current version.

Changes from Revision G (August 2013) to Revision H	Page
<ul style="list-style-type: none"> • Added <i>ESD Ratings</i> table, <i>Recommended Operating Conditions</i> table, <i>Thermal Information</i> table, <i>Feature Description</i> section, <i>Device Functional Modes</i>, <i>Application and Implementation</i> section, <i>Power Supply Recommendations</i> section, <i>Layout</i> section, <i>Device and Documentation Support</i> section, and <i>Mechanical, Packaging, and Orderable Information</i> section 	1

Changes from Revision F (September 2010) to Revision G	Page
<ul style="list-style-type: none"> • Aligned package description throughout datasheet • Removed <i>Ordering Information</i> table. 	1 1

5 Pin Configuration and Functions



Pin Functions

PIN		I/O	DESCRIPTION
NO.	NAME		
1	IN1	I	Digital control to connect COM to NO or NC
2	NO1	I/O	Normally open
3	GND	—	Ground
4	NO2	I/O	Normally open
5	IN2	I	Digital control to connect COM to NO or NC
6	COM2	I/O	Common
7	NC2	I/O	Normally closed
8	VCC	—	Power supply
9	NC1	I/O	Normally closed
10	COM1	I/O	Common

6 Specifications

6.1 Absolute Maximum Ratings

over operating free-air temperature range (unless otherwise noted)⁽¹⁾⁽²⁾

		MIN	MAX	UNIT
V_{CC}	Supply voltage ⁽³⁾	-0.5	6.5	V
V_{NC} V_{NO} V_{COM}	Analog voltage ^{(3) (4) (5)}	-0.5	$V_{CC} + 0.5$	V
I_K	Analog port diode current	$V_{NC}, V_{NO}, V_{COM} < 0$		mA
I_{NC} I_{NO} I_{COM}	On-state switch current	-200	200	mA
	On-state peak switch current ⁽⁶⁾	-400	400	
V_{IN}	Digital input voltage ^{(3) (4)}	-0.5	6.5	V
I_{IK}	Digital input clamp current	$V_I < 0$		mA
I_{CC}	Continuous current through V_{CC}		100	mA
I_{GND}	Continuous current through GND	-100	100	mA
T_{stg}	Storage temperature	-65	150	°C

- Stresses beyond those listed under *Absolute Maximum Ratings* may cause permanent damage to the device. These are stress ratings only, which do not imply functional operation of the device at these or any other conditions beyond those indicated under *Recommended Operating Conditions*. Exposure to absolute-maximum-rated conditions for extended periods may affect device reliability.
- The algebraic convention, whereby the most negative value is a minimum and the most positive value is a maximum
- All voltages are with respect to ground, unless otherwise specified.
- The input and output voltage ratings may be exceeded if the input and output clamp-current ratings are observed.
- This value is limited to 5.5 V maximum.
- Pulse at 1-ms duration < 10% duty cycle

6.2 ESD Ratings

		VALUE	UNIT
$V_{(ESD)}$ Electrostatic discharge	Human-body model (HBM), per ANSI/ESDA/JEDEC JS-001 ⁽¹⁾	±2000	V
	Charged-device model (CDM), per JEDEC specification JESD22-C101 ⁽²⁾	±1000	

(1) JEDEC document JEP155 states that 500-V HBM allows safe manufacturing with a standard ESD control process.

(2) JEDEC document JEP157 states that 250-V CDM allows safe manufacturing with a standard ESD control process.

6.3 Recommended Operating Conditions

over operating free-air temperature range (unless otherwise noted)

		MIN	MAX	UNIT
V_{CC} Supply LC Voltage		0	5.5	V
V_{NC} Analog voltage		0	V_{CC}	
V_{NO} V_{COM}				
V_{IN} Digital input voltage range		0	V_{CC}	

6.4 Thermal Information

THERMAL METRIC ⁽¹⁾		TS5A23159		UNIT
		DGS (VSSOP)	RSE (UQFN)	
		10 PINS	10 PINS	
$R_{\theta JA}$ Junction-to-ambient thermal resistance		203.9	180.8	°C/W
$R_{\theta JC(top)}$ Junction-to-case (top) thermal resistance		88.3	117.8	
$R_{\theta JB}$ Junction-to-board thermal resistance		123.9	98.6	
ψ_{JT} Junction-to-top characterization parameter		2.1	6.8	
ψ_{JB} Junction-to-board characterization parameter		122.5	98.4	
$R_{\theta JC(bot)}$ Junction-to-case (bottom) thermal resistance		—	—	

(1) For more information about traditional and new thermal metrics, see the *IC Package Thermal Metrics* application report, [SPRA953](#).

6.5 Electrical Characteristics for 5-V Supply

 $V_{CC} = 4.5\text{ V to }5.5\text{ V}$, $T_A = -40^\circ\text{C to }85^\circ\text{C}$ (unless otherwise noted)⁽¹⁾

PARAMETER		TEST CONDITIONS		T_A	V_{CC}	MIN	TYP	MAX	UNIT
ANALOG SWITCH									
V_{COM} V_{NO} V_{NC}	Analog signal range					0		V_{CC}	V
R_{peak}	Peak ON resistance	$0 \leq (V_{NO} \text{ or } V_{NC}) \leq V_{CC}$, $I_{COM} = -100\text{ mA}$,	Switch ON, See Figure 14	25°C Full	4.5 V		0.8 1.1	1.5	Ω
R_{on}	ON-state resistance	V_{NO} or $V_{NC} = 2.5\text{ V}$, $I_{COM} = -100\text{ mA}$,	Switch ON, See Figure 14	25°C Full	4.5 V		0.7 0.9	1.1	Ω
ΔR_{on}	ON-state resistance match between channels	V_{NO} or $V_{NC} = 2.5\text{ V}$, $I_{COM} = -100\text{ mA}$,	Switch ON, See Figure 14	25°C Full	4.5 V		0.05 0.1	0.1	Ω
$R_{on(Flat)}$	ON-state resistance flatness	$0 \leq (V_{NO} \text{ or } V_{NC}) \leq V_{CC}$, $I_{COM} = -100\text{ mA}$,	Switch ON, See Figure 14	25°C	4.5 V		0.15		Ω
				Full			0.1 0.25	0.25	
$I_{NO(OFF)}$, $I_{NC(OFF)}$	NC, NO OFF leakage current	V_{NC} or $V_{NO} = 1\text{ V}$, $V_{COM} = 1\text{ V to }4.5\text{ V}$, or V_{NC} or $V_{NO} = 4.5\text{ V}$, $V_{COM} = 1\text{ V to }4.5\text{ V}$,	Switch OFF, See Figure 15	25°C	5.5 V		-20 2	20	nA
				Full			-100	100	
$I_{NC(PWROFF)}$, $I_{NO(PWROFF)}$		V_{NC} or $V_{NO} = 0\text{ to }5.5\text{ V}$, $V_{COM} = 5.5\text{ V to }0$,	Switch OFF, See Figure 15	25°C	0 V		-1 0.2	1	μA
				Full			-20	20	
$I_{NO(ON)}$, $I_{NC(ON)}$	NC, NO ON leakage current	V_{NC} or $V_{NO} = 1\text{ V}$, $V_{COM} = \text{Open}$, or V_{NC} or $V_{NO} = 4.5\text{ V}$, $V_{COM} = \text{Open}$,	Switch ON, See Figure 16	25°C	5.5 V		-20 2	20	nA
				Full			-100	100	
$I_{COM(PWROFF)}$	COM OFF leakage current	V_{NC} or $V_{NO} = 0\text{ to }5.5\text{ V}$, $V_{COM} = 5.5\text{ V to }0$,	Switch OFF, See Figure 15	25°C	0 V		-1 0.1	1	μA
				Full			-20	20	
$I_{COM(ON)}$	COM ON leakage current	V_{NC} or $V_{NO} = \text{Open}$, $V_{COM} = 1\text{ V}$, or V_{NC} or $V_{NO} = \text{Open}$, $V_{COM} = 4.5\text{ V}$,	Switch ON, See Figure 16	25°C	5.5 V		-20 2	20	nA
				Full			-100	100	
DIGITAL CONTROL INPUTS (IN1, IN2)⁽²⁾									
V_{IH}	Input logic high			Full		2.4		5.5	V
V_{IL}	Input logic low			Full		0		0.8	V
I_{IH} , I_{IL}	Input leakage current	$V_{IN} = 5.5\text{ V or }0$		25°C	5.5 V			2	nA
				Full			-100	100	
DYNAMIC									
t_{ON}	Turnon time	$V_{COM} = V_{CC}$, $R_L = 50\ \Omega$,	$C_L = 35\text{ pF}$, See Figure 18	25°C	5 V	1	8	13	ns
				Full	4.5 V to 5.5 V	1		16.5	
t_{OFF}	Turnoff time	$V_{COM} = V_{CC}$, $R_L = 50\ \Omega$,	$C_L = 35\text{ pF}$, See Figure 18	25°C	5 V	1	5	8	ns
				Full	4.5 V to 5.5 V	1		8	

(1) The algebraic convention, whereby the most negative value is a minimum and the most positive value is a maximum

(2) All unused digital inputs of the device must be held at V_{CC} or GND to ensure proper device operation. Refer to the TI application report, *Implications of Slow or Floating CMOS Inputs*, [SCBA004](#).

Electrical Characteristics for 5-V Supply (continued)
 $V_{CC} = 4.5 \text{ V to } 5.5 \text{ V}$, $T_A = -40^\circ\text{C to } 85^\circ\text{C}$ (unless otherwise noted)⁽¹⁾

PARAMETER		TEST CONDITIONS		T_A	V_{CC}	MIN	TYP	MAX	UNIT
t_{BBM}	Break-before-make time	$V_{\text{NC}} = V_{\text{NO}} = V_{\text{CC}}$, $R_L = 50 \Omega$,	$C_L = 35 \text{ pF}$, See Figure 19	25°C	5 V	1	5.5	13	ns
				Full	4.5 V to 5.5 V	1		14	
Q_C	Charge injection	$V_{\text{GEN}} = 0$, $R_{\text{GEN}} = 0$,	$C_L = 1 \text{ nF}$, See Figure 23	25°C	5 V		-7		pC
$C_{\text{NC(OFF)}}$, $C_{\text{NO(OFF)}}$	NC, NO OFF capacitance	V_{NC} or $V_{\text{NO}} = V_{\text{CC}}$ or GND, Switch OFF,	See Figure 17	25°C	5 V		18		pF
$C_{\text{NC(ON)}}$, $C_{\text{NO(ON)}}$	NC, NO ON capacitance	V_{NC} or $V_{\text{NO}} = V_{\text{CC}}$ or GND, Switch ON,	See Figure 17	25°C	5 V		55		pF
$C_{\text{COM(ON)}}$	COM ON capacitance	$V_{\text{COM}} = V_{\text{CC}}$ or GND, Switch ON,	See Figure 17	25°C	5 V		54.5		pF
C_I	Digital input capacitance	$V_{\text{IN}} = V_{\text{CC}}$ or GND,	See Figure 17	25°C	5 V		2		pF
BW	Bandwidth	$R_L = 50 \Omega$, Switch ON,	See Figure 20	25°C	5 V		100		MHz
O_{ISO}	OFF isolation	$R_L = 50 \Omega$, $f = 1 \text{ MHz}$,	Switch OFF, See Figure 21	25°C	5 V		-64		dB
X_{TALK}	Crosstalk	$R_L = 50 \Omega$, $f = 1 \text{ MHz}$,	Switch ON, See Figure 22	25°C	5 V		-64		dB
THD	Total harmonic distortion	$R_L = 600 \Omega$, $C_L = 50 \text{ pF}$,	$f = 20 \text{ Hz to } 20 \text{ kHz}$, See Figure 24	25°C	5 V		0.004%		
SUPPLY									
I_{CC}	Positive supply current	$V_{\text{IN}} = V_{\text{CC}}$ or GND,	Switch ON or OFF	25°C	5.5 V		10	50	nA
				Full			750		

6.6 Electrical Characteristics for 3.3-V Supply

 $V_{CC} = 3\text{ V to }3.6\text{ V}$, $T_A = -40^\circ\text{C to }85^\circ\text{C}$ (unless otherwise noted)⁽¹⁾

PARAMETER		TEST CONDITIONS		T_A	V_{CC}	MIN	TYP	MAX	UNIT
ANALOG SWITCH									
V_{COM} , V_{NO} , V_{NC}	Analog signal range					0		V_{CC}	V
R_{peak}	Peak ON resistance	$0 \leq (V_{NO} \text{ or } V_{NC}) \leq V_{CC}$, $I_{COM} = -100\text{ mA}$,	Switch ON, See Figure 14	25°C Full	3 V		1.3 1.6	2	Ω
R_{on}	ON-state resistance	$V_{NO} \text{ or } V_{NC} = 2\text{ V}$, $I_{COM} = -100\text{ mA}$,	Switch ON, See Figure 14	25°C Full	3 V		1.2 1.5	1.7	Ω
ΔR_{on}	ON-state resistance match between channels	$V_{NO} \text{ or } V_{NC} = 2\text{ V}$, 0.8 V, $I_{COM} = -100\text{ mA}$,	Switch ON, See Figure 14	25°C Full	3 V		0.1 0.2	0.15	Ω
$R_{on(Flat)}$	ON-state resistance flatness	$0 \leq (V_{NO} \text{ or } V_{NC}) \leq V_{CC}$, $I_{COM} = -100\text{ mA}$,	Switch ON, See Figure 14	25°C Full	3 V		0.15		Ω
$I_{NO(OFF)}$, $I_{NC(OFF)}$	NC, NO OFF leakage current	$V_{NC} \text{ or } V_{NO} = 1\text{ V}$, $V_{COM} = 1\text{ V to }3\text{ V}$, or $V_{NC} \text{ or } V_{NO} = 3\text{ V}$, $V_{COM} = 1\text{ V to }3\text{ V}$,	Switch OFF, See Figure 15	25°C	3.6 V	-20	2	20	nA
Full				-50			50		
$I_{NC(PWROFF)}$, $I_{NO(PWROFF)}$		$V_{NC} \text{ or } V_{NO} = 0\text{ to }3.6\text{ V}$, $V_{COM} = 3.6\text{ V to }0$,	Switch OFF, See Figure 15	25°C	0 V	-1	0.2	1	μA
Full				-15			15		
$I_{NO(ON)}$, $I_{NC(ON)}$	NC, NO ON leakage current	$V_{NC} \text{ or } V_{NO} = 1\text{ V}$, $V_{COM} = \text{Open}$, or $V_{NC} \text{ or } V_{NO} = 3\text{ V}$, $V_{COM} = \text{Open}$,	Switch ON, See Figure 16	25°C	3.6 V	-10	2	10	nA
Full				-20			20		
$I_{COM(PWROFF)}$	COM OFF leakage current	$V_{NC} \text{ or } V_{NO} = 3.6\text{ V to }0$, $V_{COM} = 0\text{ to }3.6\text{ V}$,	Switch OFF, See Figure 15	25°C Full	0 V	-1 -15	0.2	1 15	μA
$I_{COM(ON)}$	COM ON leakage current	$V_{NC} \text{ or } V_{NO} = \text{Open}$, $V_{COM} = 1\text{ V}$, or $V_{NC} \text{ or } V_{NO} = \text{Open}$, $V_{COM} = 3\text{ V}$,	Switch ON, See Figure 16	25°C Full	3.6 V	-10 -20	2	10 20	nA
DIGITAL CONTROL INPUTS (IN1, IN2)⁽²⁾									
V_{IH}	Input logic high			Full		2		5.5	V
V_{IL}	Input logic low			Full		0		0.8	V
I_{IH} , I_{IL}	Input leakage current	$V_{IN} = 5.5\text{ V or }0$		25°C	3.6 V	-2		2	nA
Full				-20			20		
DYNAMIC									
t_{ON}	Turnon time	$V_{COM} = V_{CC}$, $R_L = 50\ \Omega$,	$C_L = 35\text{ pF}$, See Figure 18	25°C	3.3 V	5	11	19	ns
Full				3 V to 3.6 V	3		22		
t_{OFF}	Turnoff time	$V_{COM} = V_{CC}$, $R_L = 50\ \Omega$,	$C_L = 35\text{ pF}$, See Figure 18	25°C	3.3 V	1	5	9	ns
Full				3 V to 3.6 V	1		9		
t_{BBM}	Break-before-make time	$V_{NC} = V_{NO} = V_{CC}$, $R_L = 50\ \Omega$,	$C_L = 35\text{ pF}$, See Figure 19	25°C	3.3 V	1	7	17	ns
Full				3 V to 3.6 V	1		20		

(1) The algebraic convention, whereby the most negative value is a minimum and the most positive value is a maximum

(2) All unused digital inputs of the device must be held at V_{CC} or GND to ensure proper device operation. Refer to the TI application report, *Implications of Slow or Floating CMOS Inputs*, [SCBA004](#).

Electrical Characteristics for 3.3-V Supply (continued)
 $V_{CC} = 3\text{ V to }3.6\text{ V}$, $T_A = -40^\circ\text{C to }85^\circ\text{C}$ (unless otherwise noted)⁽¹⁾

PARAMETER		TEST CONDITIONS		T_A	V_{CC}	MIN	TYP	MAX	UNIT
Q_C	Charge injection	$V_{GEN} = 0$, $R_{GEN} = 0$,	$C_L = 1\text{ nF}$, See Figure 23	25°C	3.3 V		-4		pC
$C_{NC(OFF)}$, $C_{NO(OFF)}$	NC, NO OFF capacitance	V_{NC} or $V_{NO} = V_{CC}$ or GND, Switch OFF,	See Figure 17	25°C	3.3 V		18		pF
$C_{NC(ON)}$, $C_{NO(ON)}$	NC, NO ON capacitance	V_{NC} or $V_{NO} = V_{CC}$ or GND, Switch ON,	See Figure 17	25°C	3.3 V		56		pF
$C_{COM(ON)}$	COM ON capacitance	$V_{COM} = V_{CC}$ or GND, Switch ON,	See Figure 17	25°C	3.3 V		56		pF
C_I	Digital input capacitance	$V_{IN} = V_{CC}$ or GND,	See Figure 17	25°C	3.3 V		2		pF
BW	Bandwidth	$R_L = 50\ \Omega$, Switch ON,	See Figure 20	25°C	3.3 V		100		MHz
O_{ISO}	OFF isolation	$R_L = 50\ \Omega$, $f = 1\text{ MHz}$,	Switch OFF, See Figure 21	25°C	3.3 V		-64		dB
X_{TALK}	Crosstalk	$R_L = 50\ \Omega$, $f = 1\text{ MHz}$,	Switch ON, See Figure 22	25°C	3.3 V		-64		dB
THD	Total harmonic distortion	$R_L = 600\ \Omega$, $C_L = 50\text{ pF}$,	$f = 20\text{ Hz to }20\text{ kHz}$, See Figure 24	25°C	3.3 V		0.01%		
SUPPLY									
I_{CC}	Positive supply current	$V_{IN} = V_{CC}$ or GND,	Switch ON or OFF	25°C	3.6 V			25	nA
				Full				150	

6.7 Electrical Characteristics for 2.5-V Supply⁽¹⁾

 $V_{CC} = 2.3 \text{ V to } 2.7 \text{ V}$, $T_A = -40^\circ\text{C to } 85^\circ\text{C}$ (unless otherwise noted)

PARAMETER		TEST CONDITIONS		T_A	V_{CC}	MIN	TYP	MAX	UNIT	
ANALOG SWITCH										
V_{COM} , V_{NO} , V_{NC}	Analog signal range					0		V_{CC}	V	
R_{peak}	Peak ON resistance	$0 \leq (V_{NO} \text{ or } V_{NC}) \leq V_{CC}$, $I_{COM} = -8 \text{ mA}$,	Switch ON, See Figure 14	25°C	2.3 V		1.8	2.5	Ω	
				Full			2.7			
R_{on}	ON-state resistance	$V_{NO} \text{ or } V_{NC} = 1.8 \text{ V}$, $I_{COM} = -8 \text{ mA}$,	Switch ON, See Figure 14	25°C	2.3 V		1.5	2	Ω	
				Full			2.4			
ΔR_{on}	ON-state resistance match between channels	$V_{NO} \text{ or } V_{NC} = 1.8 \text{ V}$, 0.8 V, $I_{COM} = -8 \text{ mA}$,	Switch ON, See Figure 14	25°C	2.3 V		0.15	0.2	Ω	
				Full			0.2			
$R_{on(Flat)}$	ON-state resistance flatness	$0 \leq (V_{NO} \text{ or } V_{NC}) \leq V_{CC}$, $I_{COM} = -8 \text{ mA}$,	Switch ON, See Figure 14	25°C	2.3 V		0.6		Ω	
				25°C			0.6	1		
				Full				1		
$I_{NO(OFF)}$, $I_{NC(OFF)}$	NC, NO OFF leakage current	$V_{NC} \text{ or } V_{NO} = 0.5 \text{ V}$, $V_{COM} = 0.5 \text{ V to } 2.3 \text{ V}$, or $V_{NC} \text{ or } V_{NO} = 2.2 \text{ V}$, $V_{COM} = 0.5 \text{ V to } 2.3 \text{ V}$,	Switch OFF, See Figure 15	25°C	2.3 V		-20	2	20	nA
				Full			-50	50		
$I_{NC(PWROFF)}$, $I_{NO(PWROFF)}$		$V_{NC} \text{ or } V_{NO} = 0 \text{ to } 2.7 \text{ V}$, $V_{COM} = 2.7 \text{ V to } 0$,	Switch OFF, See Figure 15	25°C	0 V		-1	0.1	1.0	μA
				Full			-10	10		
$I_{NO(ON)}$, $I_{NC(ON)}$	NC, NO ON leakage current	$V_{NC} \text{ or } V_{NO} = 0.5 \text{ V}$, $V_{COM} = \text{Open}$, or $V_{NC} \text{ or } V_{NO} = 2.2 \text{ V}$, $V_{COM} = \text{Open}$,	Switch ON, See Figure 16	25°C	2.7 V		-10	2	10	nA
				Full			-20	20		
$I_{COM(PWROFF)}$	COM OFF leakage current	$V_{NC} \text{ or } V_{NO} = 2.7 \text{ V to } 0$, $V_{COM} = 0 \text{ to } 2.7 \text{ V}$,	Switch OFF, See Figure 15	25°C	0 V		-1	0.1	1	μA
				Full			-10	10		
$I_{COM(ON)}$	COM ON leakage current	$V_{NC} \text{ or } V_{NO} = \text{Open}$, $V_{COM} = 0.5 \text{ V}$, or $V_{NC} \text{ or } V_{NO} = \text{Open}$, $V_{COM} = 2.2 \text{ V}$,	Switch ON, See Figure 16	25°C	2.7 V		-10	2	10	nA
				Full			-20	20		
DIGITAL CONTROL INPUTS (IN1, IN2)⁽²⁾										
V_{IH}	Input logic high			Full		1.8		5.5	V	
V_{IL}	Input logic low			Full		0		0.6	V	
I_{IH} , I_{IL}	Input leakage current	$V_{IN} = 5.5 \text{ V or } 0$		25°C	2.7 V		-2	2	nA	
				Full			-20	20		
DYNAMIC										
t_{ON}	Turnon time	$V_{COM} = V_{CC}$, $R_L = 50 \Omega$,	$C_L = 35 \text{ pF}$, See Figure 18	25°C	2.5 V	5	15	28	ns	
				Full	2.3 V to 2.7 V	5		32		
t_{OFF}	Turnoff time	$V_{COM} = V_{CC}$, $R_L = 50 \Omega$,	$C_L = 35 \text{ pF}$, See Figure 18	25°C	2.5 V	2	6	9	ns	
				Full	2.3 V to 2.7 V	2		10		
t_{BBM}	Break-before-make time	$V_{NC} = V_{NO} = V_{CC}$, $R_L = 50 \Omega$,	$C_L = 35 \text{ pF}$, See Figure 19	25°C	2.5 V	1	10	27	ns	
				Full	2.3 V to 2.7 V	1		30		

(1) The algebraic convention, whereby the most negative value is a minimum and the most positive value is a maximum

(2) All unused digital inputs of the device must be held at V_{CC} or GND to ensure proper device operation. Refer to the TI application report, *Implications of Slow or Floating CMOS Inputs*, [SCBA004](#).

Electrical Characteristics for 2.5-V Supply⁽¹⁾ (continued)
 $V_{CC} = 2.3 \text{ V to } 2.7 \text{ V}$, $T_A = -40^\circ\text{C to } 85^\circ\text{C}$ (unless otherwise noted)

PARAMETER		TEST CONDITIONS		T_A	V_{CC}	MIN	TYP	MAX	UNIT
Q_C	Charge injection	$V_{GEN} = 0$, $R_{GEN} = 0$,	$C_L = 1 \text{ nF}$, See Figure 23	25°C	2.5 V		-3		pC
$C_{NC(OFF)}$, $C_{NO(OFF)}$	NC, NO OFF capacitance	V_{NC} or $V_{NO} = V_{CC}$ or GND, Switch OFF,	See Figure 17	25°C	2.5 V		18.5		pF
$C_{NC(ON)}$, $C_{NO(ON)}$	NC, NO ON capacitance	V_{NC} or $V_{NO} = V_{CC}$ or GND, Switch ON,	See Figure 17	25°C	2.5 V		56.5		pF
$C_{COM(ON)}$	COM ON capacitance	$V_{COM} = V_{CC}$ or GND, Switch ON,	See Figure 17	25°C	2.5 V		56.5		pF
C_I	Digital input capacitance	$V_{IN} = V_{CC}$ or GND,	See Figure 17	25°C	2.5 V		2		pF
BW	Bandwidth	$R_L = 50 \Omega$, Switch ON,	See Figure 20	25°C	2.5 V		100		MHz
O_{ISO}	OFF isolation	$R_L = 50 \Omega$, $f = 1 \text{ MHz}$,	Switch OFF, See Figure 21	25°C	2.5 V		-64		dB
X_{TALK}	Crosstalk	$R_L = 50 \Omega$, $f = 1 \text{ MHz}$,	Switch ON, See Figure 22	25°C	2.5 V		-64		dB
THD	Total harmonic distortion	$R_L = 600 \Omega$, $C_L = 50 \text{ pF}$,	$f = 20 \text{ Hz to } 20 \text{ kHz}$, See Figure 24	25°C	2.5 V		0.02%		
SUPPLY									
I_{CC}	Positive supply current	$V_{IN} = V_{CC}$ or GND,	Switch ON or OFF	25°C	2.7 V	10		25	nA
				Full		100			

6.8 Electrical Characteristics for 1.8-V Supply

 $V_{CC} = 1.65\text{ V to }1.95\text{ V}$, $T_A = -40^\circ\text{C to }85^\circ\text{C}$ (unless otherwise noted)⁽¹⁾

PARAMETER		TEST CONDITIONS		T_A	V_{CC}	MIN	TYP	MAX	UNIT
ANALOG SWITCH									
V_{COM} , V_{NO} , V_{NC}	Analog signal range					0		V_{CC}	V
R_{peak}	Peak ON resistance	$0 \leq (V_{NO} \text{ or } V_{NC}) \leq V_{CC}$, $I_{COM} = -2\text{ mA}$,	Switch ON, See Figure 14	25°C	1.65 V	5		15	Ω
				Full					
R_{on}	ON-state resistance	$V_{NO} \text{ or } V_{NC} = 1.5\text{ V}$, $I_{COM} = -2\text{ mA}$,	Switch ON, See Figure 14	25°C	1.65 V	2		2.5	Ω
				Full		3.5			
ΔR_{on}	ON-state resistance match between channels	$V_{NO} \text{ or } V_{NC} = 0.6\text{ V}, 1.5\text{ V}$, $I_{COM} = -2\text{ mA}$,	Switch ON, See Figure 14	25°C	1.65 V	0.15		0.4	Ω
				Full		0.4			
$R_{on(Flat)}$	ON-state resistance flatness	$0 \leq (V_{NO} \text{ or } V_{NC}) \leq V_{CC}$, $I_{COM} = -2\text{ mA}$,	Switch ON, See Figure 14	25°C	1.65 V	5		Ω	
				25°C		4.5			
				Full					
$I_{NO(OFF)}$, $I_{NC(OFF)}$	NC, NO OFF leakage current	$V_{NC} \text{ or } V_{NO} = 0.3\text{ V}$, $V_{COM} = 0.3\text{ V to }1.65\text{ V}$, or $V_{NC} \text{ or } V_{NO} = 1.65\text{ V}$, $V_{COM} = 0.3\text{ V to }1.65\text{ V}$	Switch OFF, See Figure 15	25°C	1.65 V	-20	2	20	nA
				Full		-50	50		
$I_{NC(PWROFF)}$, $I_{NO(PWROFF)}$		$V_{NC} \text{ or } V_{NO} = 0\text{ to }1.95\text{ V}$, $V_{COM} = 1.95\text{ V to }0$,	Switch OFF, See Figure 15	25°C	0 V	-1	0.1	1	μA
				Full		-5	5		
$I_{NO(ON)}$, $I_{NC(ON)}$	NC, NO ON leakage current	$V_{NC} \text{ or } V_{NO} = 0.3\text{ V}$, $V_{COM} = \text{Open}$, or $V_{NC} \text{ or } V_{NO} = 1.65\text{ V}$, $V_{COM} = \text{Open}$,	Switch ON, See Figure 16	25°C	1.95 V	-5	2	5	nA
				Full		-20	20		
$I_{COM(PWROFF)}$	COM OFF leakage current	$V_{NC} \text{ or } V_{NO} = 1.95\text{ V to }0$, $V_{COM} = 0\text{ to }1.95\text{ V}$,	Switch OFF, See Figure 15	25°C	0 V	-1	0.1	1	μA
				Full		-5	5		
$I_{COM(ON)}$	COM ON leakage current	$V_{NC} \text{ or } V_{NO} = \text{Open}$, $V_{COM} = 0.3\text{ V}$, or $V_{NC} \text{ or } V_{NO} = \text{Open}$, $V_{COM} = 1.65\text{ V}$,	Switch ON, See Figure 16	25°C	1.95 V	-10	2	10	nA
				Full		-20	20		
DIGITAL CONTROL INPUTS (IN1, IN2)									
V_{IH}	Input logic high			Full		1.5		5.5	V
V_{IL}	Input logic low			Full		0		0.6	V
I_{IH} , I_{IL}	Input leakage current	$V_{IN} = 5.5\text{ V or }0$		25°C	1.95 V	-2		2	nA
				Full		-20	20		
DYNAMIC									
t_{ON}	Turnon time	$V_{COM} = V_{CC}$, $R_L = 50\ \Omega$,	$C_L = 35\text{ pF}$, See Figure 18	25°C	1.8 V	10	27.5	48.5	ns
				Full	1.65 V to 1.95 V	10	55		
t_{OFF}	Turnoff time	$V_{COM} = V_{CC}$, $R_L = 50\ \Omega$,	$C_L = 35\text{ pF}$, See Figure 18	25°C	1.8 V	2	6.5	11	ns
				Full	1.65 V to 1.95 V	2	12		

(1) The algebraic convention, whereby the most negative value is a minimum and the most positive value is a maximum

Electrical Characteristics for 1.8-V Supply (continued)
 $V_{CC} = 1.65\text{ V to }1.95\text{ V}$, $T_A = -40^\circ\text{C to }85^\circ\text{C}$ (unless otherwise noted)⁽¹⁾

PARAMETER		TEST CONDITIONS		T_A	V_{CC}	MIN	TYP	MAX	UNIT
t_{BBM}	Break-before-make time	$V_{NC} = V_{NO} = V_{CC}$, $R_L = 50\ \Omega$,	$C_L = 35\text{ pF}$, See Figure 19	25°C	1.8 V	1	18	50	ns
				Full	1.65 V to 1.95 V	1		55	
Q_C	Charge injection	$V_{GEN} = 0$, $R_{GEN} = 0$,	$C_L = 1\text{ nF}$, See Figure 23	25°C	1.8 V		2		pC
$C_{NC(OFF)}$, $C_{NO(OFF)}$	NC, NO OFF capacitance	V_{NC} or $V_{NO} = V_{CC}$ or GND, Switch OFF,	See Figure 17	25°C	1.8 V		18.5		pF
$C_{NC(ON)}$, $C_{NO(ON)}$	NC, NO ON capacitance	V_{NC} or $V_{NO} = V_{CC}$ or GND, Switch ON,	See Figure 17	25°C	1.8 V		56.5		pF
$C_{COM(ON)}$	COM ON capacitance	$V_{COM} = V_{CC}$ or GND, Switch ON,	See Figure 17	25°C	1.8 V		56.5		pF
C_I	Digital input capacitance	$V_{IN} = V_{CC}$ or GND,	See Figure 17	25°C	1.8 V		2		pF
BW	Bandwidth	$R_L = 50\ \Omega$, Switch ON,	See Figure 20	25°C	1.8 V		105		MHz
O_{ISO}	OFF isolation	$R_L = 50\ \Omega$, $f = 1\text{ MHz}$,	Switch OFF, See Figure 21	25°C	1.8 V		-64		dB
X_{TALK}	Crosstalk	$R_L = 50\ \Omega$, $f = 1\text{ MHz}$,	Switch ON, See Figure 22	25°C	1.8 V		-64		dB
THD	Total harmonic distortion	$R_L = 600\ \Omega$, $C_L = 50\text{ pF}$,	$f = 20\text{ Hz to }20\text{ kHz}$, See Figure 24	25°C	1.8 V		0.06%		
SUPPLY									
I_{CC}	Positive supply current	$V_{IN} = V_{CC}$ or GND,	Switch ON or OFF	25°C	1.95 V		10	25	nA
				Full				50	

6.9 Typical Characteristics

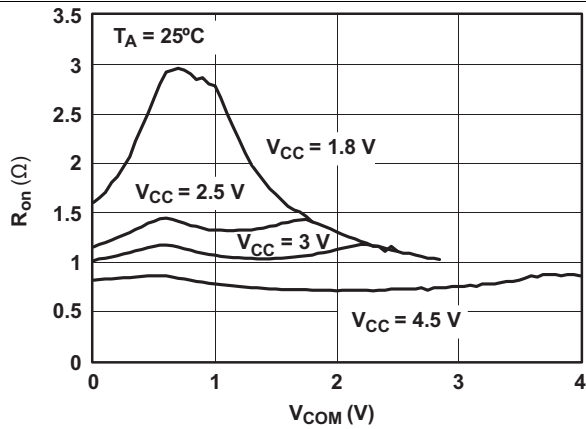

Figure 1. R_{on} vs V_{COM}

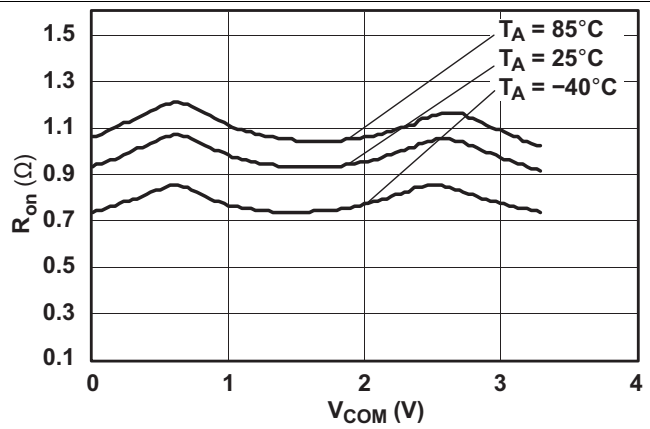

Figure 2. R_{on} vs V_{COM} ($V_{CC} = 3.3\text{ V}$)

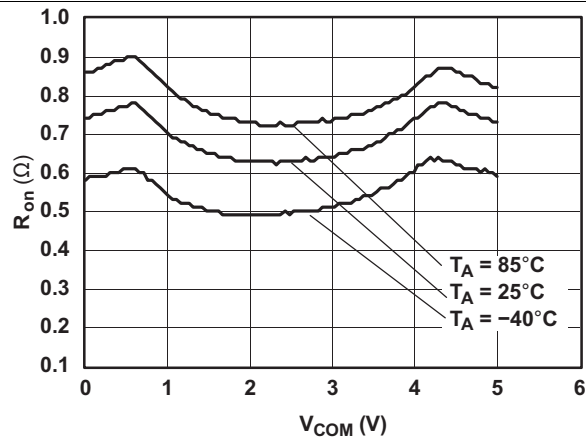

Figure 3. R_{on} vs V_{COM} ($V_{CC} = 5\text{ V}$)

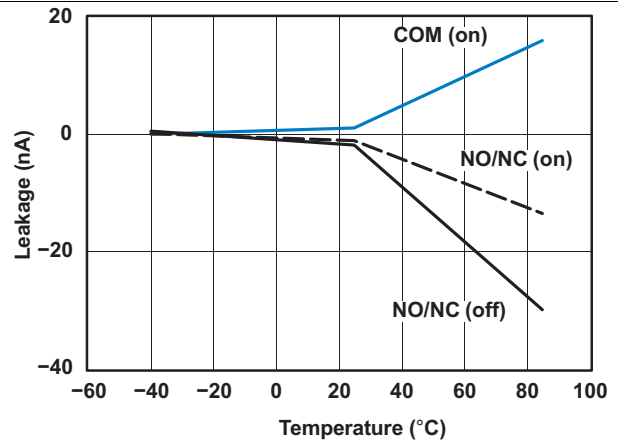

Figure 4. Leakage Current vs Temperature ($V_{CC} = 3.3\text{ V}$)

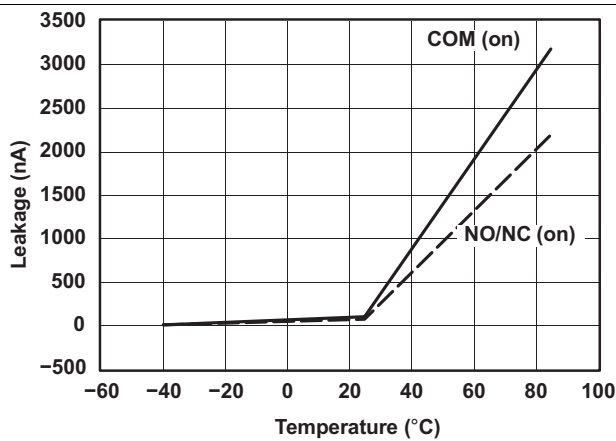

Figure 5. Leakage Current vs Temperature ($V_{CC} = 5\text{ V}$)

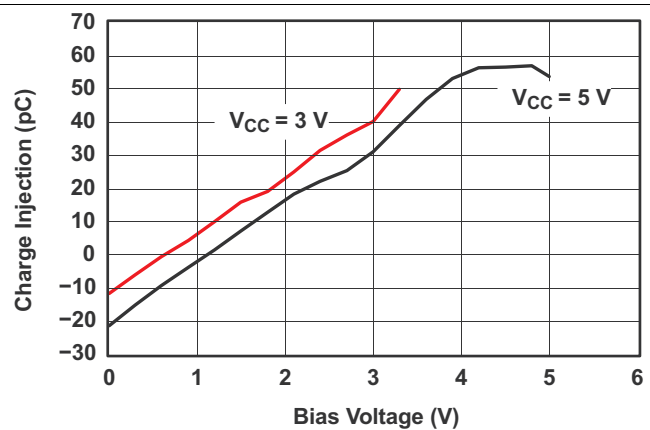
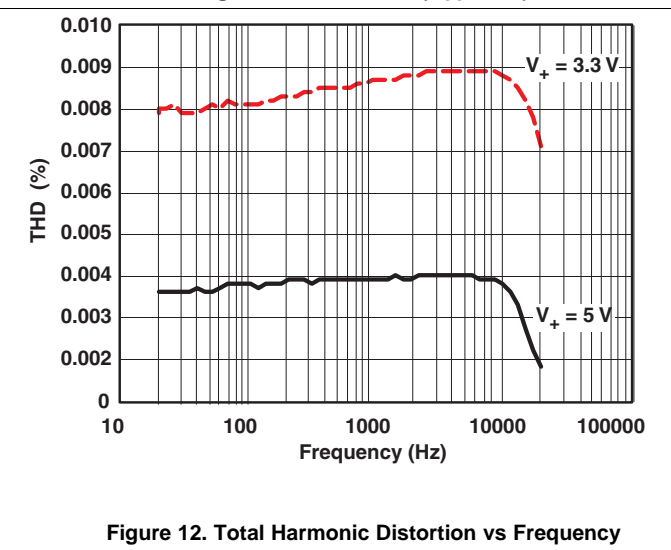
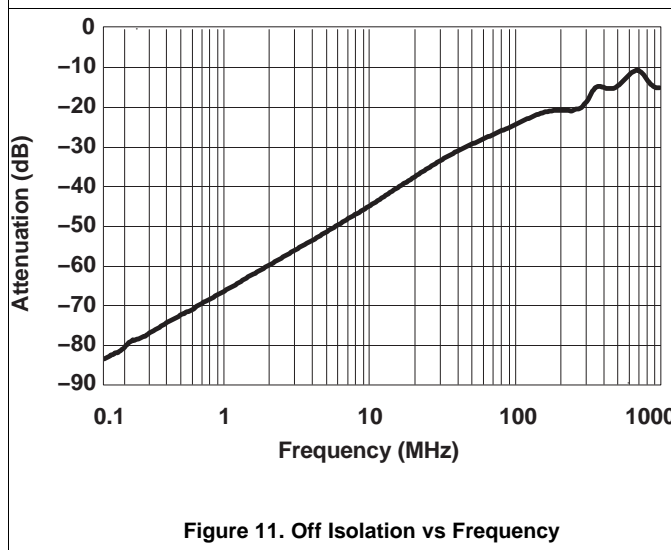
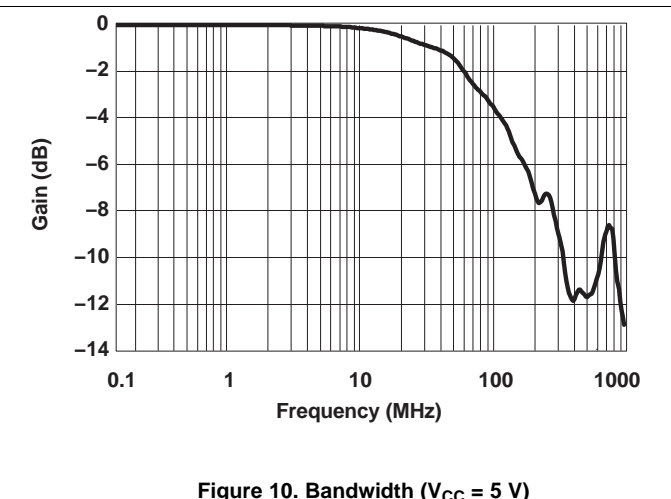
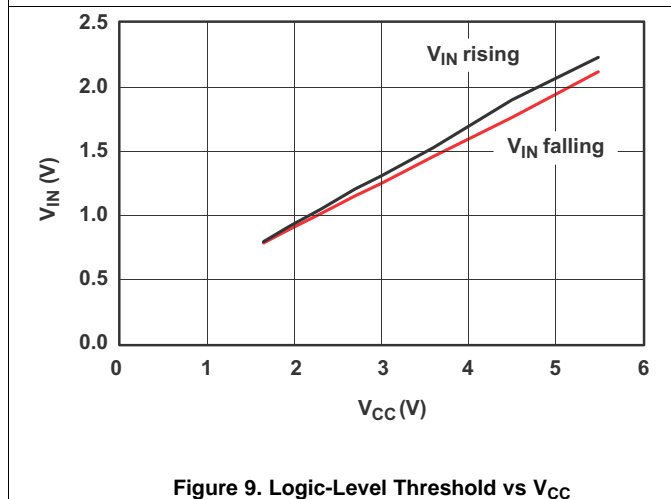
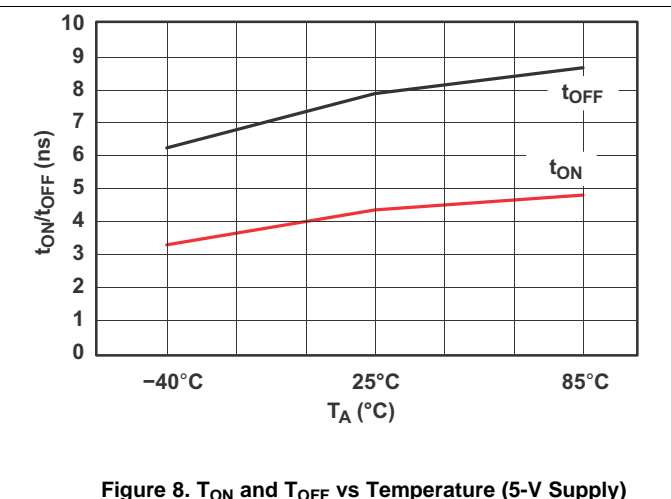
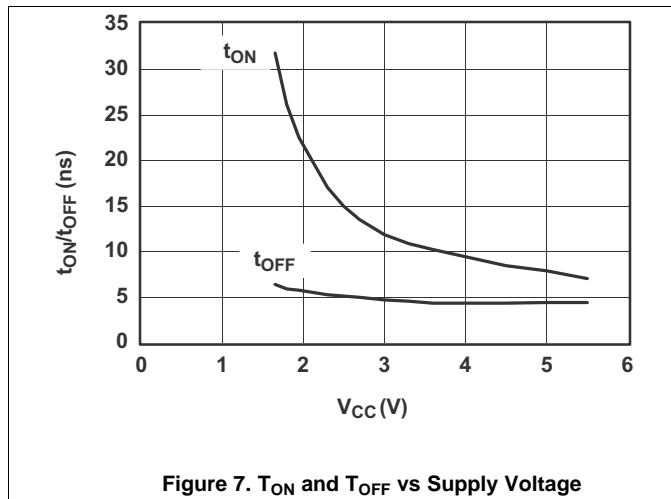

Figure 6. Charge Injection (Q_C) vs V_{COM}

Typical Characteristics (continued)



Typical Characteristics (continued)

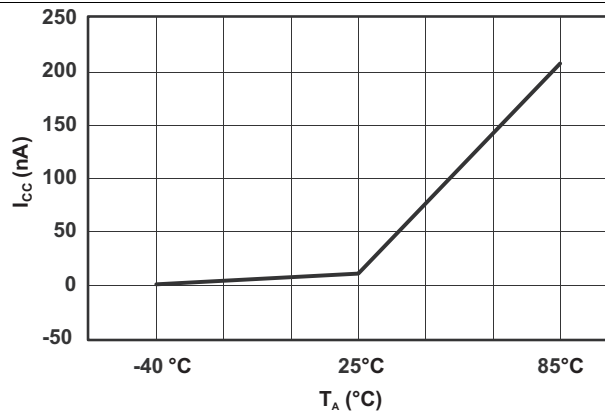

Figure 13. Power-Supply Current vs Temperature ($V_{CC} = 5\text{ V}$)

7 Parameter Measurement Information

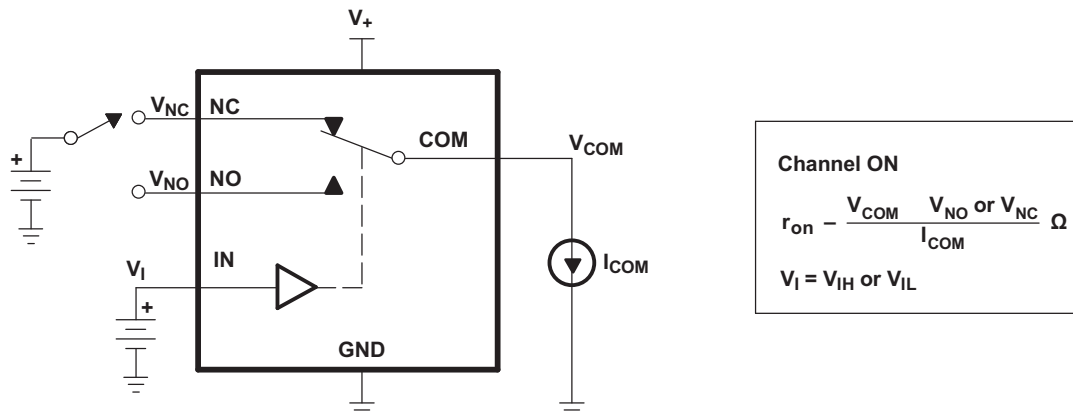

Figure 14. ON-State Resistance (R_{on})

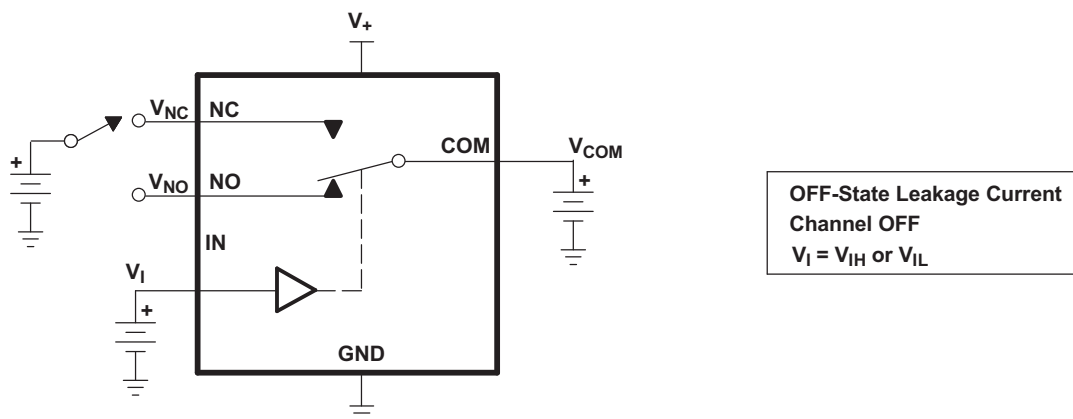

Figure 15. OFF-State Leakage Current
 ($I_{NC(OFF)}$, $I_{NC(PWROFF)}$, $I_{NO(OFF)}$, $I_{NO(PWROFF)}$, $I_{COM(OFF)}$, $I_{COM(PWROFF)}$)

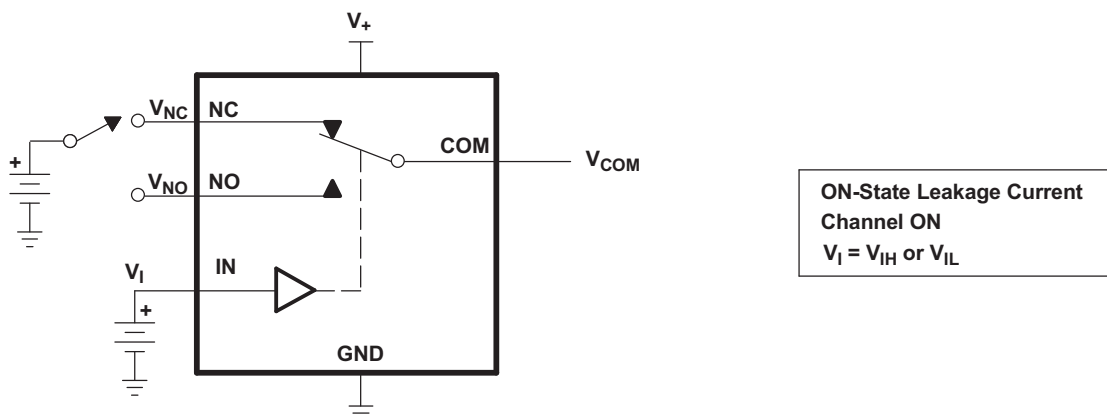

Figure 16. ON-State Leakage Current ($I_{COM(ON)}$, $I_{NC(ON)}$, $I_{NO(ON)}$)

Parameter Measurement Information (continued)

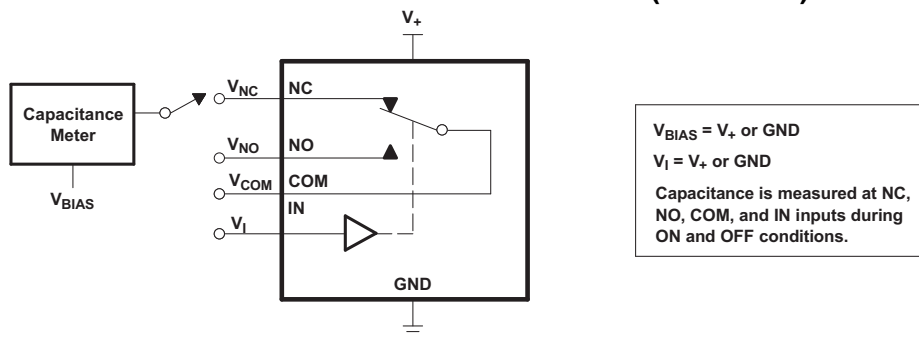
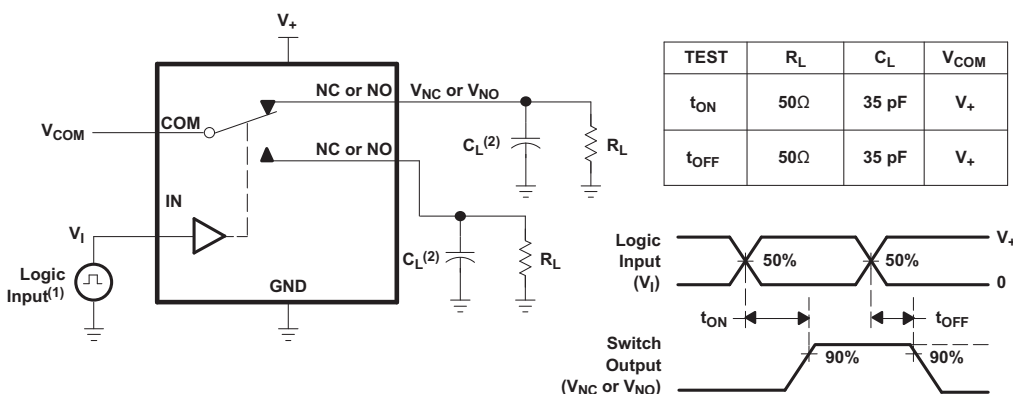
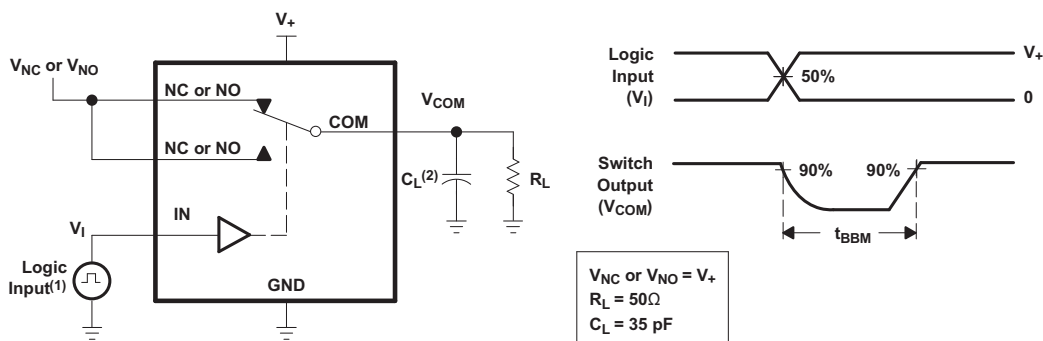

Figure 17. Capacitance (C_I , $C_{COM(ON)}$, $C_{NC(OFF)}$, $C_{NO(OFF)}$, $C_{NC(ON)}$, $C_{NO(ON)}$)



1. All input pulses are supplied by generators having the following characteristics:
 PRR 3 10 MHz, $Z_O = 50 \Omega$, $t_r < 5 \text{ ns}$, $t_f < 5 \text{ ns}$.
2. C_L includes probe and jig capacitance.

Figure 18. Turnon (T_{ON}) and Turnoff Time (T_{OFF})



1. All input pulses are supplied by generators having the following characteristics:
 PRR 3 10 MHz, $Z_O = 50 \Omega$, $t_r < 5 \text{ ns}$, $t_f < 5 \text{ ns}$.
2. C_L includes probe and jig capacitance.

Figure 19. Break-Before-Make Time (T_{BBM})

Parameter Measurement Information (continued)

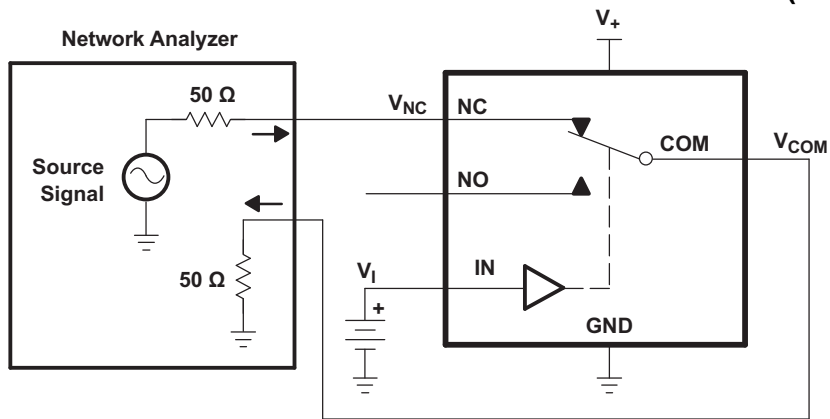

Channel ON: NC to COM
 $V_I = V_+$ or GND

Network Analyzer Setup
 Source Power = 0 dBm
 (632-mV P-P at 50-Ω load)
 DC Bias = 350 mV

Figure 20. Bandwidth (Bw)

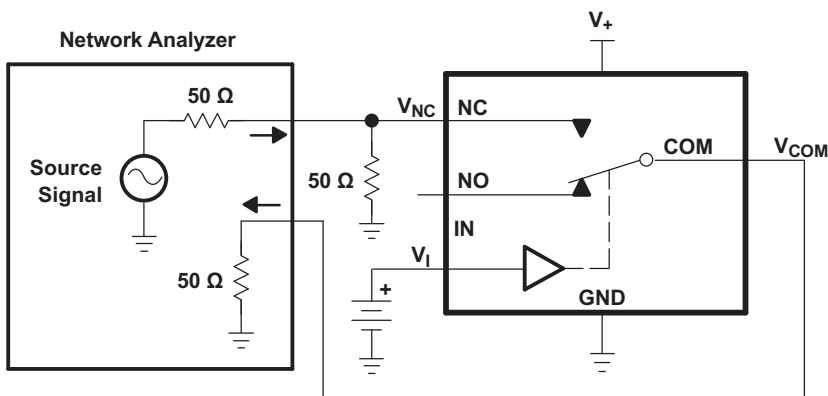

Channel OFF: NC to COM
 $V_I = V_+$ or GND

Network Analyzer Setup
 Source Power = 0 dBm
 (632-mV P-P at 50-Ω load)
 DC Bias = 350 mV

Figure 21. Off Isolation (O_{ISO})

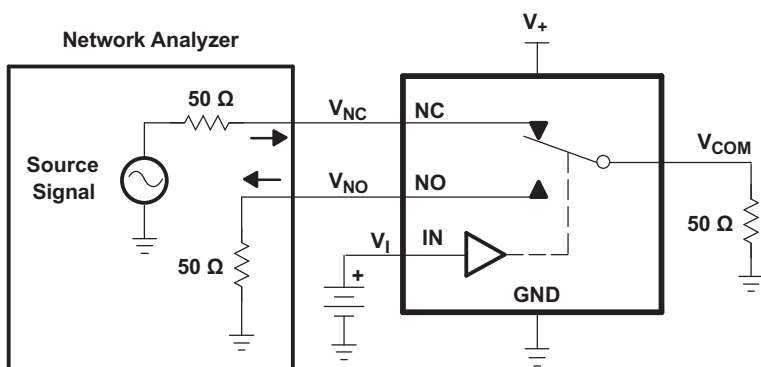

Channel ON: NC to COM
 Channel OFF: NO to COM
 $V_I = V_+$ or GND

Network Analyzer Setup
 Source Power = 0 dBm
 (632-mV P-P at 50-Ω load)
 DC Bias = 350 mV

Figure 22. Crosstalk (X_{TALK})

Parameter Measurement Information (continued)

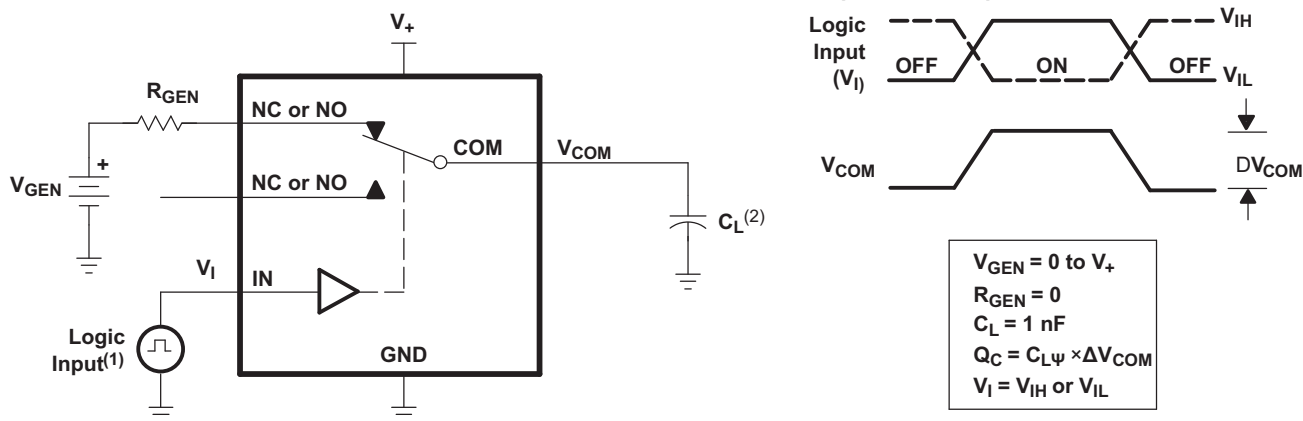

1. All input pulses are supplied by generators having the following characteristics:
 PRR 3 10 MHz, $Z_O = 50 \Omega$, $t_r < 5 \text{ ns}$, $t_f < 5 \text{ ns}$.
2. C_L includes probe and jig capacitance.

Figure 23. Charge Injection (Q_C)

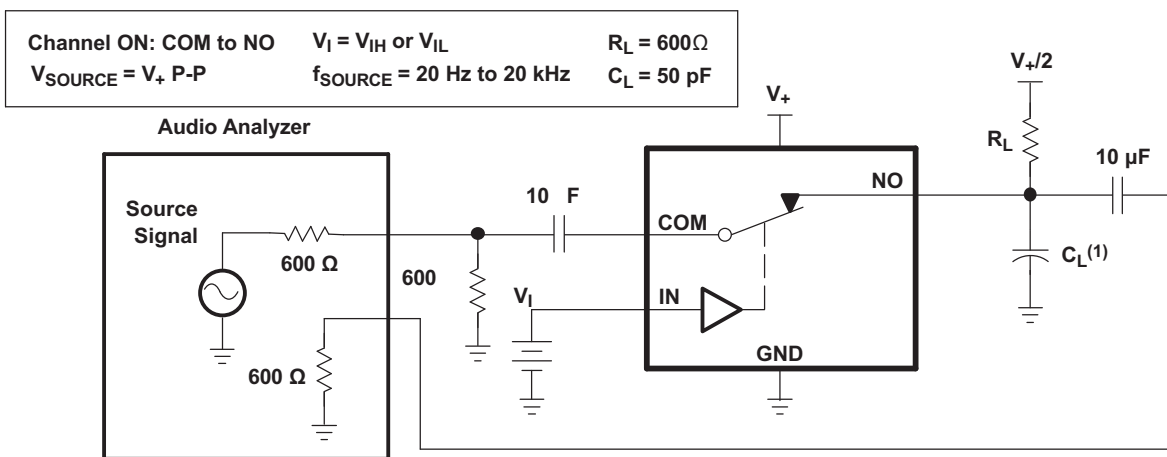

1. C_L includes probe and jig capacitance.

Figure 24. Total Harmonic Distortion (THD)

Parameter Measurement Information (continued)
Table 1. Parameter Description

SYMBOL	DESCRIPTION
V_{COM}	Voltage at COM
V_{NC}	Voltage at NC
V_{NO}	Voltage at NO
R_{on}	Resistance between COM and NC or COM and NO ports when the channel is ON
R_{peak}	Peak on-state resistance over a specified voltage range
ΔR_{on}	Difference of R_{on} between channels in a specific device
$R_{on(flat)}$	Difference between the maximum and minimum value of R_{on} in a channel over the specified range of conditions
$I_{NC(OFF)}$	Leakage current measured at the NC port, with the corresponding channel (NC to COM) in the OFF state under worst-case input and output conditions
$I_{NC(PWROFF)}$	Leakage current measured at the NC port during the power-down condition, $V_{CC} = 0$
$I_{NO(OFF)}$	Leakage current measured at the NO port, with the corresponding channel (NO to COM) in the OFF state under worst-case input and output conditions
$I_{NO(PWROFF)}$	Leakage current measured at the NO port during the power-down condition, $V_{CC} = 0$
$I_{NC(ON)}$	Leakage current measured at the NC port, with the corresponding channel (NC to COM) in the ON state and the output (COM) open
$I_{NO(ON)}$	Leakage current measured at the NO port, with the corresponding channel (NO to COM) in the ON state and the output (COM) open
$I_{COM(ON)}$	Leakage current measured at the COM port, with the corresponding channel (COM to NO or COM to NC) in the ON state and the output (NC or NO) open
$I_{COM(PWROFF)}$	Leakage current measured at the COM port during the power-down condition, $V_{CC} = 0$
V_{IH}	Minimum input voltage for logic high for the control input (IN)
V_{IL}	Maximum input voltage for logic low for the control input (IN)
V_{IN}	Voltage at the control input (IN)
I_{IH}, I_{IL}	Leakage current measured at the control input (IN)
t_{ON}	Turnon time for the switch. This parameter is measured under the specified range of conditions and by the propagation delay between the digital control (IN) signal and analog output (COM, NC, or NO) signal when the switch is turning ON.
t_{OFF}	Turnoff time for the switch. This parameter is measured under the specified range of conditions and by the propagation delay between the digital control (IN) signal and analog output (COM, NC, or NO) signal when the switch is turning OFF.
t_{BBM}	Break-before-make time. This parameter is measured under the specified range of conditions and by the propagation delay between the output of two adjacent analog channels (NC and NO) when the control signal changes state.
Q_C	Charge injection is a measurement of unwanted signal coupling from the control (IN) input to the analog (NO or COM) output. This is measured in coulomb (C) and measured by the total charge induced due to switching of the control input. Charge injection, $Q_C = C_L \times \Delta V_{COM}$. C_L is the load capacitance and ΔV_{COM} is the change in analog output voltage.
$C_{NC(OFF)}$	Capacitance at the NC port when the corresponding channel (NC to COM) is OFF
$C_{NO(OFF)}$	Capacitance at the NO port when the corresponding channel (NO to COM) is OFF
$C_{NC(ON)}$	Capacitance at the NC port when the corresponding channel (NC to COM) is ON
$C_{NO(ON)}$	Capacitance at the NO port when the corresponding channel (NO to COM) is ON
$C_{COM(ON)}$	Capacitance at the COM port when the corresponding channel (COM to NC or COM to NO) is ON
C_I	Capacitance of control input (IN)
O_{ISO}	OFF isolation of the switch is a measurement of OFF-state switch impedance. This is measured in dB in a specific frequency, with the corresponding channel (NC to COM or NO to COM) in the OFF state.
X_{TALK}	Crosstalk is a measurement of unwanted signal coupling from an ON channel to an OFF channel (NC to NO or NO to NC). This is measured in a specific frequency and in dB.
BW	Bandwidth of the switch. This is the frequency in which the gain of an ON channel is –3 dB below the DC gain.
THD	Total harmonic distortion is defined as the ratio of the root mean square (RMS) value of the second, third, and higher harmonics to the magnitude of fundamental harmonic.
I_{CC}	Static power-supply current with the control (IN) pin at V_{CC} or GND

8 Detailed Description

8.1 Overview

The TS5A23159 is a bidirectional 2-channel single-pole double-throw (SPDT) switch that is designed to operate from 1.65 V to 5.5 V. The device offers low ON-state resistance and excellent ON-state resistance matching with the break-before-make feature which prevents signal distortion during the transferring of a signal from one channel to another. The device has an excellent total harmonic distortion (THD) performance and consumes very low power. These features make this device suitable for a wide variety of portable applications including cell phones, audio devices, and instrumentation.

8.2 Functional Block Diagram

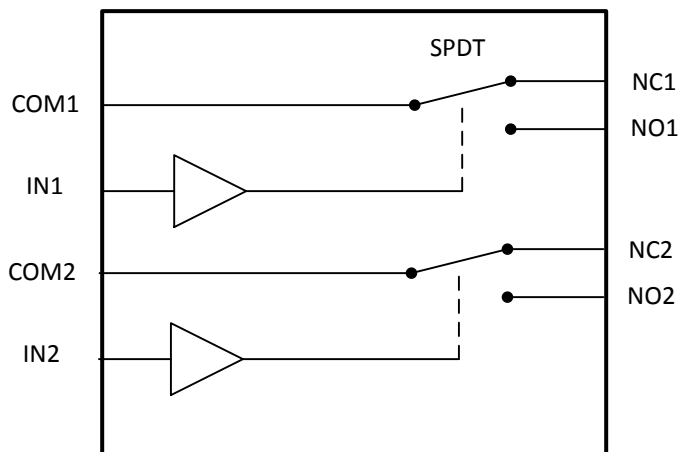

8.3 Feature Description

The TS5A23159 is a bidirectional device that has two single-pole, double-throw switches. The two channels of the switch are controlled independently by two digital signals; one digital control for each single-pole, double-throw switch.

8.4 Device Functional Modes

Table 2. Function Table

IN	NC to COM, COM to NC	NO to COM, COM to NO
L	ON	OFF
H	OFF	ON

9 Application and Implementation

NOTE

Information in the following applications sections is not part of the TI component specification, and TI does not warrant its accuracy or completeness. TI's customers are responsible for determining suitability of components for their purposes. Customers should validate and test their design implementation to confirm system functionality.

9.1 Application Information

The switches are bidirectional, so the NO, NC, and COM pins can be used as either inputs or outputs.

9.2 Typical Application

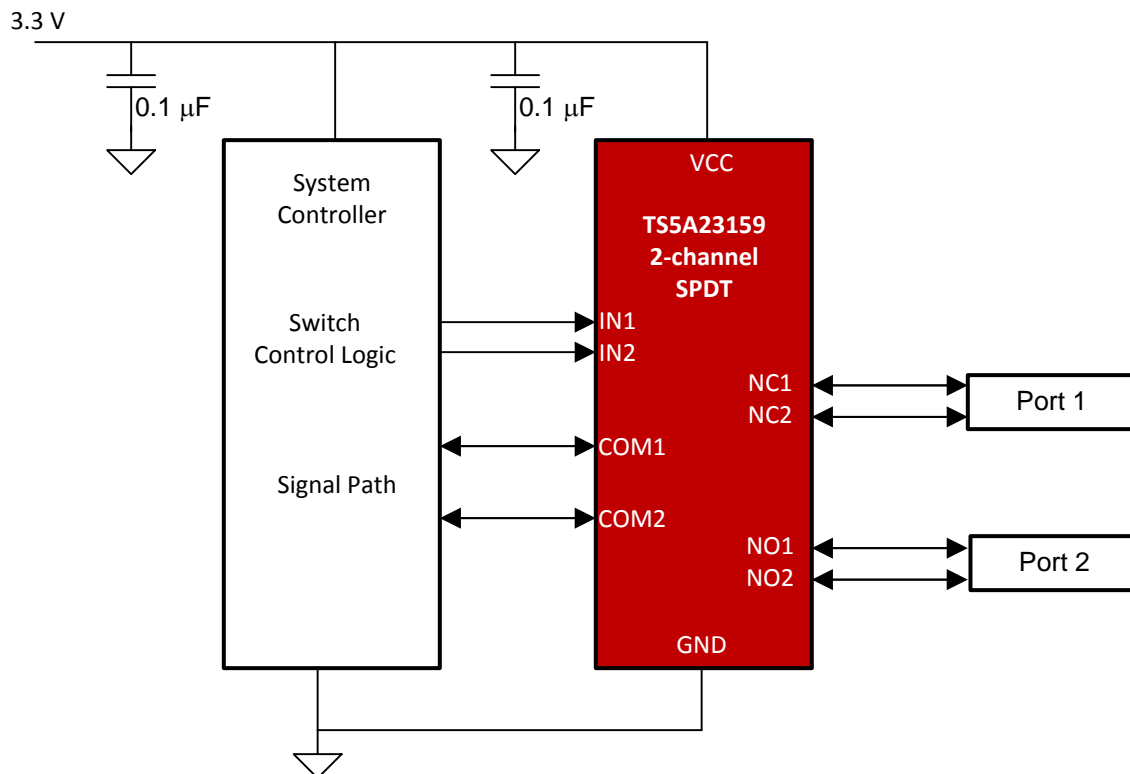

Figure 25. Typical Application Diagram

9.2.1 Design Requirements

Ensure that all of the signals passing through the switch are within the specified ranges in the recommended operating conditions to ensure proper performance.

9.2.2 Detailed Design Procedure

The TS5A23159 can be properly operated without any external components. However, TI recommends connecting unused pins to ground through a 50-Ω resistor to prevent signal reflections back into the device. TI also recommends that the digital control pins (INX) be pulled up to VCC or down to GND to avoid undesired switch positions that could result from the floating pin.

Typical Application (continued)

9.2.3 Application Curve

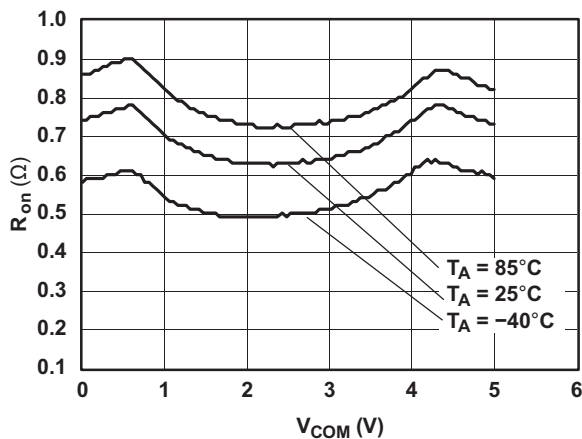

Figure 26. R_{on} vs V_{COM} (V_{CC} = 5 V)

10 Power Supply Recommendations

Proper power-supply sequencing is recommended for all CMOS devices. Do not exceed the absolute maximum ratings, because stresses beyond the listed ratings can cause permanent damage to the device. Always sequence VCC on first, followed by NO, NC, or COM. Although it is not required, power-supply bypassing improves noise margin and prevents switching noise propagation from the VCC supply to other components. A 0.1-μF capacitor, connected from VCC to GND, is adequate for most applications.

11 Layout

11.1 Layout Guidelines

High-speed switches require proper layout and design procedures for optimum performance. Reduce stray inductance and capacitance by keeping traces short and wide. Ensure that bypass capacitors are as close to the device as possible. Use large ground planes where possible.

11.2 Layout Example

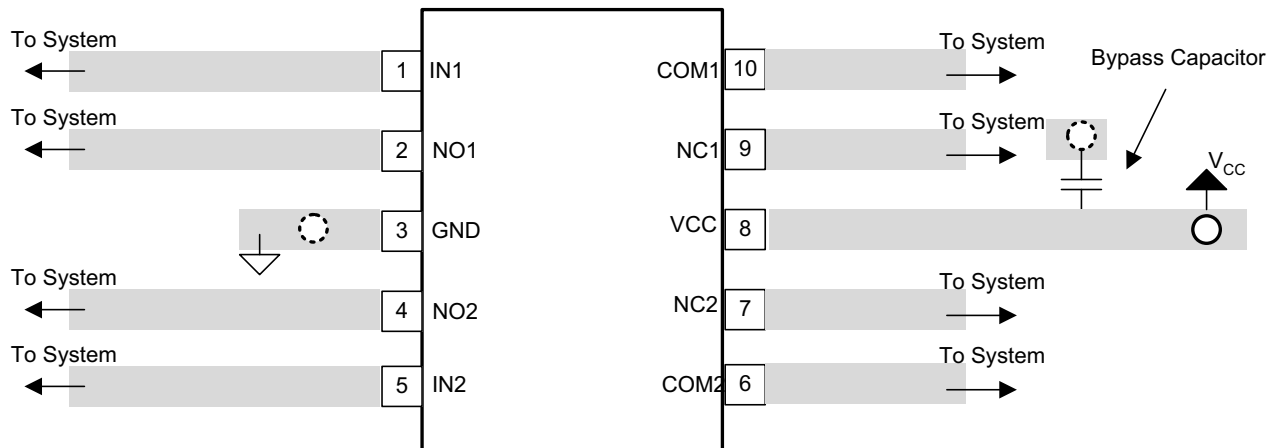
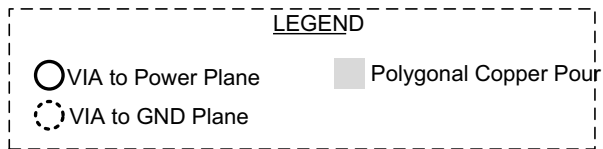

Figure 27. Layout Recommendation

12 Device and Documentation Support

12.1 Trademarks

All trademarks are the property of their respective owners.

12.2 Electrostatic Discharge Caution



These devices have limited built-in ESD protection. The leads should be shorted together or the device placed in conductive foam during storage or handling to prevent electrostatic damage to the MOS gates.

12.3 Glossary

[SLYZ022](#) — *TI Glossary*.

This glossary lists and explains terms, acronyms, and definitions.

13 Mechanical, Packaging, and Orderable Information

The following pages include mechanical, packaging, and orderable information. This information is the most current data available for the designated devices. This data is subject to change without notice and revision of this document. For browser-based versions of this data sheet, refer to the left-hand navigation.

PACKAGING INFORMATION

Orderable Device	Status (1)	Package Type	Package Drawing	Pins	Package Qty	Eco Plan (2)	Lead finish/ Ball material (6)	MSL Peak Temp (3)	Op Temp (°C)	Device Marking (4/5)	Samples
TS5A23159DGSR	ACTIVE	VSSOP	DGS	10	2500	RoHS & Green	NIPDAU	Level-1-260C-UNLIM	-40 to 85	(JEQ, JER)	Samples
TS5A23159DGSRG4	LIFEBUY	VSSOP	DGS	10	2500	RoHS & Green	NIPDAU	Level-1-260C-UNLIM	-40 to 85	(JEQ, JER)	
TS5A23159DGST	LIFEBUY	VSSOP	DGS	10	250	RoHS & Green	NIPDAU	Level-1-260C-UNLIM	-40 to 85	JER	
TS5A23159DGSTE4	LIFEBUY	VSSOP	DGS	10	250	RoHS & Green	NIPDAU	Level-1-260C-UNLIM	-40 to 85	JER	
TS5A23159DGSTG4	LIFEBUY	VSSOP	DGS	10	250	RoHS & Green	NIPDAU	Level-1-260C-UNLIM	-40 to 85	JER	
TS5A23159RSER	ACTIVE	UQFN	RSE	10	3000	RoHS & Green	NIPDAU NIPDAUAG	Level-1-260C-UNLIM	-40 to 85	(JE7, JEO, JER, JE V)	Samples
TS5A23159RSERG4	LIFEBUY	UQFN	RSE	10	3000	RoHS & Green	NIPDAUAG	Level-1-260C-UNLIM	-40 to 85	(JE7, JEO, JER, JE V)	

(1) The marketing status values are defined as follows:

ACTIVE: Product device recommended for new designs.

LIFEBUY: TI has announced that the device will be discontinued, and a lifetime-buy period is in effect.

NRND: Not recommended for new designs. Device is in production to support existing customers, but TI does not recommend using this part in a new design.

PREVIEW: Device has been announced but is not in production. Samples may or may not be available.

OBSELETE: TI has discontinued the production of the device.

(2) **RoHS:** TI defines "RoHS" to mean semiconductor products that are compliant with the current EU RoHS requirements for all 10 RoHS substances, including the requirement that RoHS substance do not exceed 0.1% by weight in homogeneous materials. Where designed to be soldered at high temperatures, "RoHS" products are suitable for use in specified lead-free processes. TI may reference these types of products as "Pb-Free".

RoHS Exempt: TI defines "RoHS Exempt" to mean products that contain lead but are compliant with EU RoHS pursuant to a specific EU RoHS exemption.

Green: TI defines "Green" to mean the content of Chlorine (Cl) and Bromine (Br) based flame retardants meet JS709B low halogen requirements of <=1000ppm threshold. Antimony trioxide based flame retardants must also meet the <=1000ppm threshold requirement.

(3) MSL, Peak Temp. - The Moisture Sensitivity Level rating according to the JEDEC industry standard classifications, and peak solder temperature.

(4) There may be additional marking, which relates to the logo, the lot trace code information, or the environmental category on the device.

(5) Multiple Device Markings will be inside parentheses. Only one Device Marking contained in parentheses and separated by a "-" will appear on a device. If a line is indented then it is a continuation of the previous line and the two combined represent the entire Device Marking for that device.

(6) Lead finish/Ball material - Orderable Devices may have multiple material finish options. Finish options are separated by a vertical ruled line. Lead finish/Ball material values may wrap to two lines if the finish value exceeds the maximum column width.

Important Information and Disclaimer: The information provided on this page represents TI's knowledge and belief as of the date that it is provided. TI bases its knowledge and belief on information provided by third parties, and makes no representation or warranty as to the accuracy of such information. Efforts are underway to better integrate information from third parties. TI has taken and continues to take reasonable steps to provide representative and accurate information but may not have conducted destructive testing or chemical analysis on incoming materials and chemicals. TI and TI suppliers consider certain information to be proprietary, and thus CAS numbers and other limited information may not be available for release.

In no event shall TI's liability arising out of such information exceed the total purchase price of the TI part(s) at issue in this document sold by TI to Customer on an annual basis.

TAPE AND REEL INFORMATION

QUADRANT ASSIGNMENTS FOR PIN 1 ORIENTATION IN TAPE

*All dimensions are nominal

Device	Package Type	Package Drawing	Pins	SPQ	Reel Diameter (mm)	Reel Width W1 (mm)	A0 (mm)	B0 (mm)	K0 (mm)	P1 (mm)	W (mm)	Pin1 Quadrant
TS5A23159DGSR	VSSOP	DGS	10	2500	330.0	12.4	5.3	3.4	1.4	8.0	12.0	Q1
TS5A23159DGST	VSSOP	DGS	10	250	330.0	12.4	5.3	3.4	1.4	8.0	12.0	Q1
TS5A23159RSER	UQFN	RSE	10	3000	180.0	9.5	1.7	2.3	0.75	4.0	8.0	Q1
TS5A23159RSER	UQFN	RSE	10	3000	180.0	9.5	1.7	2.2	0.75	4.0	8.0	Q1

TAPE AND REEL BOX DIMENSIONS

*All dimensions are nominal

Device	Package Type	Package Drawing	Pins	SPQ	Length (mm)	Width (mm)	Height (mm)
TS5A23159DGSR	VSSOP	DGS	10	2500	358.0	335.0	35.0
TS5A23159DGST	VSSOP	DGS	10	250	358.0	335.0	35.0
TS5A23159RSER	UQFN	RSE	10	3000	184.0	184.0	19.0
TS5A23159RSER	UQFN	RSE	10	3000	189.0	185.0	36.0

DGS0010A

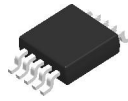

PACKAGE OUTLINE

VSSOP - 1.1 mm max height

SMALL OUTLINE PACKAGE



4221984/A 05/2015

NOTES:

- All linear dimensions are in millimeters. Any dimensions in parenthesis are for reference only. Dimensioning and tolerancing per ASME Y14.5M.
- This drawing is subject to change without notice.
- This dimension does not include mold flash, protrusions, or gate burrs. Mold flash, protrusions, or gate burrs shall not exceed 0.15 mm per side.
- This dimension does not include interlead flash. Interlead flash shall not exceed 0.25 mm per side.
- Reference JEDEC registration MO-187, variation BA.

EXAMPLE BOARD LAYOUT

DGS0010A

VSSOP - 1.1 mm max height

SMALL OUTLINE PACKAGE



LAND PATTERN EXAMPLE
SCALE:10X

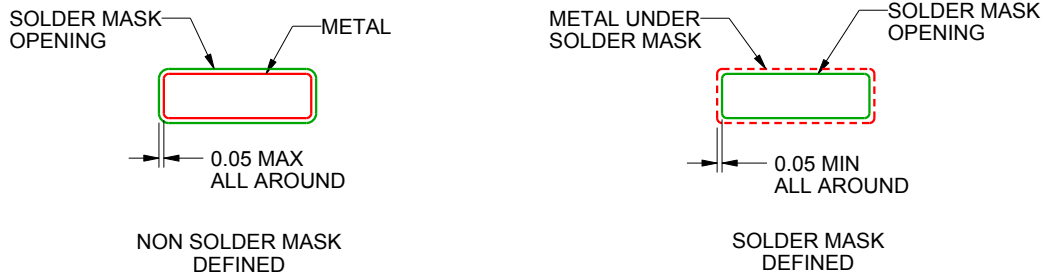

SOLDER MASK DETAILS
NOT TO SCALE

4221984/A 05/2015

NOTES: (continued)

- 6. Publication IPC-7351 may have alternate designs.
- 7. Solder mask tolerances between and around signal pads can vary based on board fabrication site.

EXAMPLE STENCIL DESIGN

DGS0010A

VSSOP - 1.1 mm max height

SMALL OUTLINE PACKAGE



SOLDER PASTE EXAMPLE
BASED ON 0.125 mm THICK STENCIL
SCALE:10X

4221984/A 05/2015

NOTES: (continued)

8. Laser cutting apertures with trapezoidal walls and rounded corners may offer better paste release. IPC-7525 may have alternate design recommendations.
9. Board assembly site may have different recommendations for stencil design.

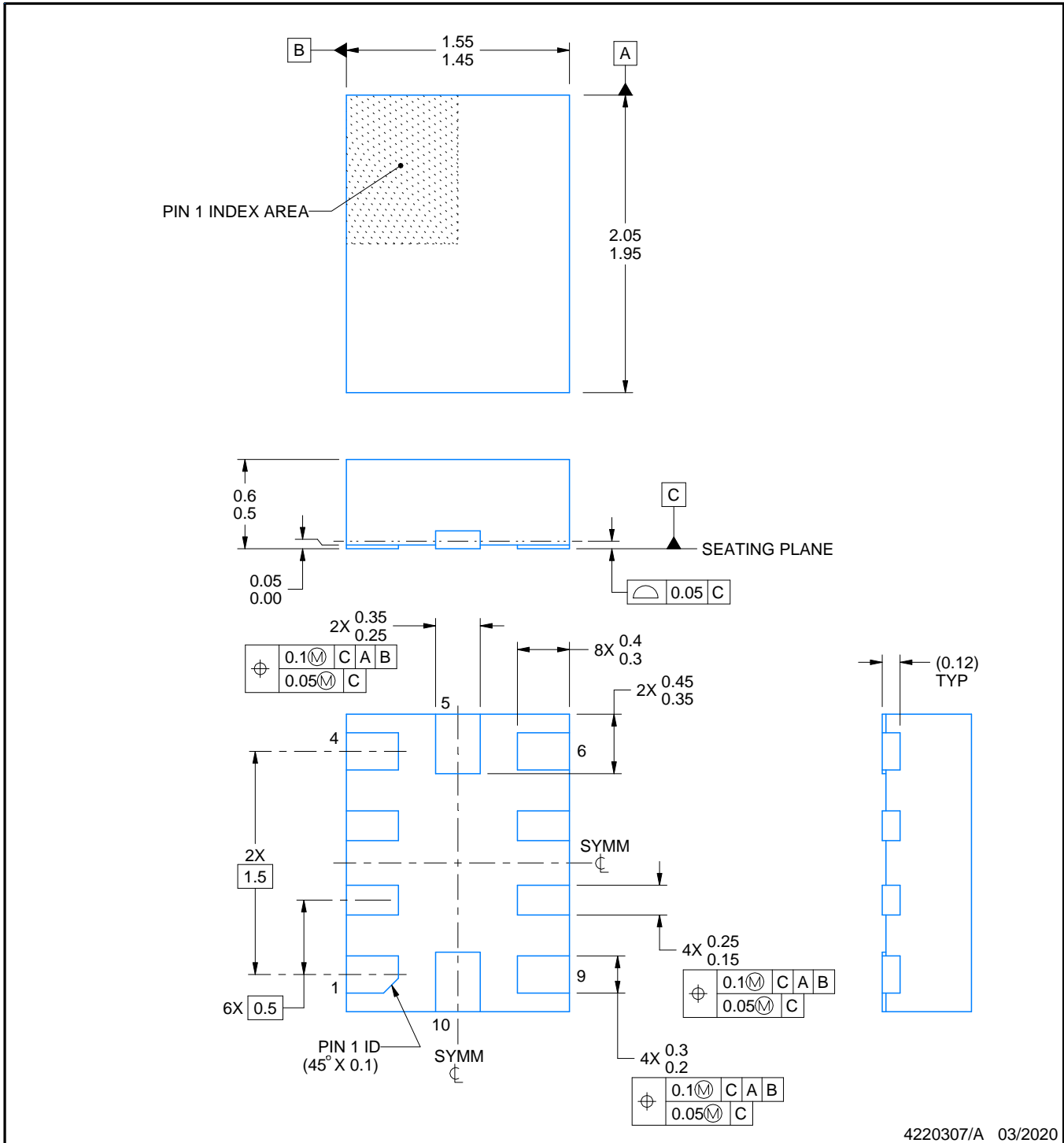
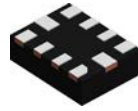

4220307/A 03/2020

NOTES:

1. All linear dimensions are in millimeters. Any dimensions in parenthesis are for reference only. Dimensioning and tolerancing per ASME Y14.5M.
2. This drawing is subject to change without notice.

EXAMPLE BOARD LAYOUT

RSE0010A

UQFN - 0.6 mm max height

PLASTIC QUAD FLATPACK - NO LEAD

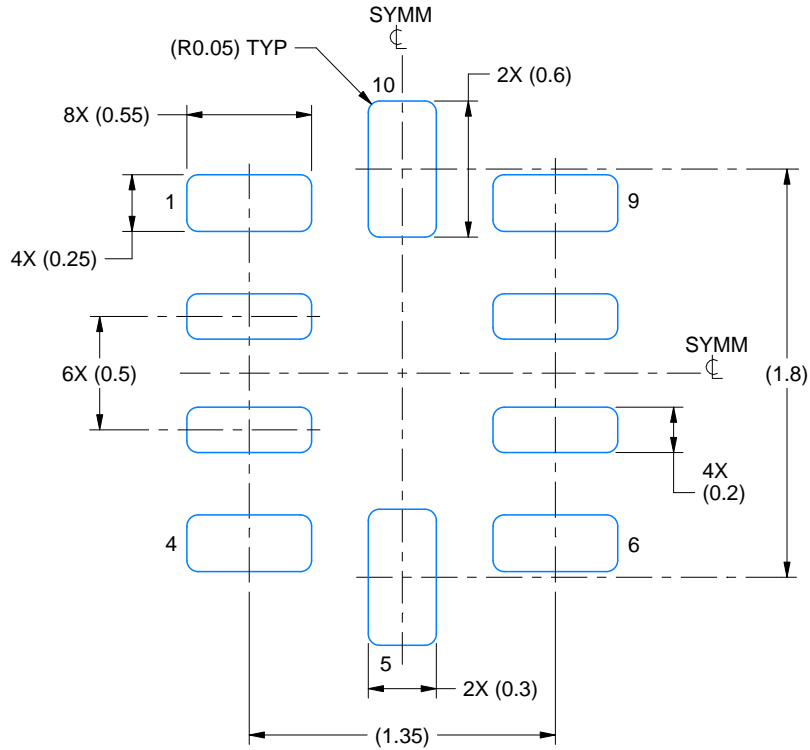

LAND PATTERN EXAMPLE
EXPOSED METAL SHOWN
SCALE:30X

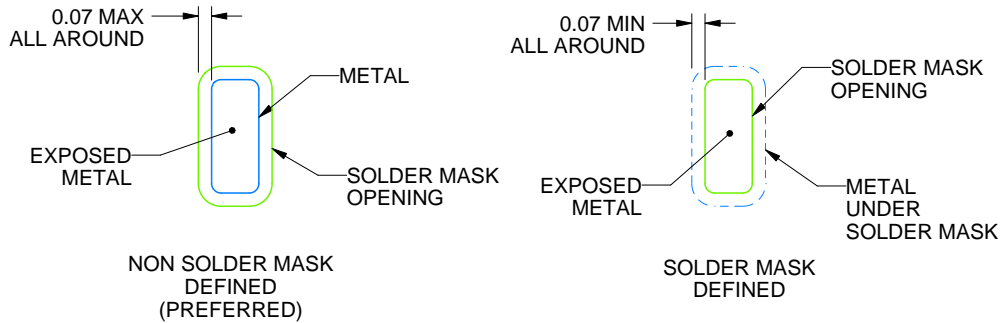

SOLDER MASK DETAILS
NOT TO SCALE

4220307/A 03/2020

NOTES: (continued)

3. For more information, see Texas Instruments literature number SLUA271 (www.ti.com/lit/slua271).

IMPORTANT NOTICE AND DISCLAIMER

TI PROVIDES TECHNICAL AND RELIABILITY DATA (INCLUDING DATA SHEETS), DESIGN RESOURCES (INCLUDING REFERENCE DESIGNS), APPLICATION OR OTHER DESIGN ADVICE, WEB TOOLS, SAFETY INFORMATION, AND OTHER RESOURCES "AS IS" AND WITH ALL FAULTS, AND DISCLAIMS ALL WARRANTIES, EXPRESS AND IMPLIED, INCLUDING WITHOUT LIMITATION ANY IMPLIED WARRANTIES OF MERCHANTABILITY, FITNESS FOR A PARTICULAR PURPOSE OR NON-INFRINGEMENT OF THIRD PARTY INTELLECTUAL PROPERTY RIGHTS.

These resources are intended for skilled developers designing with TI products. You are solely responsible for (1) selecting the appropriate TI products for your application, (2) designing, validating and testing your application, and (3) ensuring your application meets applicable standards, and any other safety, security, regulatory or other requirements.

These resources are subject to change without notice. TI grants you permission to use these resources only for development of an application that uses the TI products described in the resource. Other reproduction and display of these resources is prohibited. No license is granted to any other TI intellectual property right or to any third party intellectual property right. TI disclaims responsibility for, and you will fully indemnify TI and its representatives against, any claims, damages, costs, losses, and liabilities arising out of your use of these resources.

TI's products are provided subject to [TI's Terms of Sale](#) or other applicable terms available either on [ti.com](https://www.ti.com) or provided in conjunction with such TI products. TI's provision of these resources does not expand or otherwise alter TI's applicable warranties or warranty disclaimers for TI products.

TI objects to and rejects any additional or different terms you may have proposed.

Mailing Address: Texas Instruments, Post Office Box 655303, Dallas, Texas 75265
Copyright © 2024, Texas Instruments Incorporated

Looking for pricing, stock, or lifecycle information?

Click below to explore more details on WIN SOURCE:

 [View TS5A23159RSER on WIN SOURCE](#)

 [Texas Instruments](#) Information

Optimize Your Supply Chain with WIN SOURCE Solutions

-  Global Sourcing Solution
-  Obsolete Management
-  Cost Control Management
-  Shortage Management
-  Alternative Solution
-  Excess Inventory Management