



**THE DATASHEET OF
TS5A22364DRCR**



TS5A22362 0.65-Ω 2-channel SPDT Analog Switches With Negative Signaling Capability

1 Features

- Specified Break-Before-Make Switching
- Negative Signaling Capability: Maximum Swing from -2.75 V to 2.75 V ($V_{CC} = 2.75\text{ V}$)
- Low ON-State Resistance ($0.65\ \Omega$ Typical)
- Low Charge Injection
- Excellent ON-State Resistance Matching
- 2.3-V to 5.5-V Power Supply (V_{CC})
- Latch-Up Performance Exceeds 100 mA Per JESD 78, Class II
- ESD Performance Tested Per JESD 22
 - 2500-V Human-Body Model (A114-B, Class II)
 - 1500-V Charged-Device Model (C101)
 - 200-V Machine Model (A115-A)

2 Applications

- Cell Phones
- PDAs
- Portable Instrumentation
- Audio Routing
- Medical Imaging

3 Description

The TS5A22362 is a bidirectional, 2-channel single-pole double-throw (SPDT) analog switch designed to operate from 2.3 V to 5.5 V. The device features negative signal swing capability that allows signals below ground to pass through the switch without distortion. The break-before-make feature prevents signal distortion during the transferring of a signal from one path to another. Low ON-state resistance, excellent channel-to-channel ON-state resistance matching, and minimal total harmonic distortion (THD) performance are ideal for audio applications. The 3.00 mm × 3.00 mm DRC package is also available as a nonmagnetic package for medical imaging application.

Device Information⁽¹⁾

PART NUMBER	PACKAGE	BODY SIZE (NOM)
TS5A22362	VSON (10)	3.00 mm × 3.00 mm
	DSBGA (10)	1.86 mm × 1.36 mm
	VSSOP (10)	3.00 mm × 3.00 mm

(1) For all available packages, see the orderable addendum at the end of the data sheet.

Typical Application Schematic

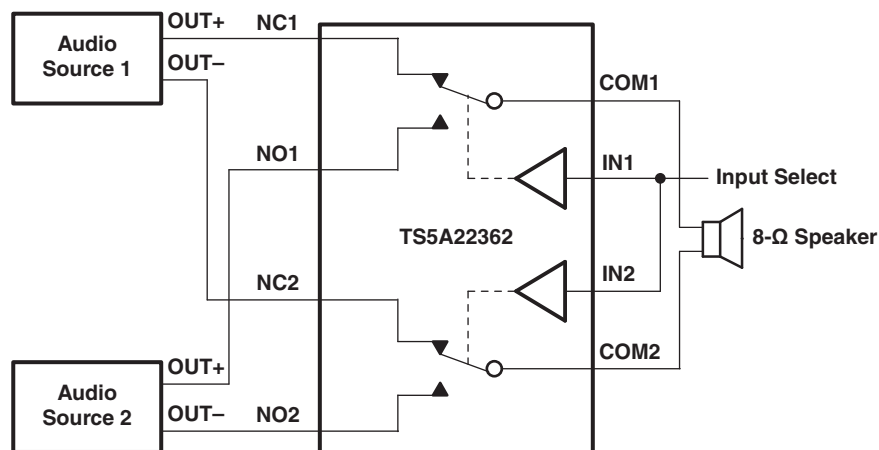

Table of Contents

1	Features	1	8.2	Functional Block Diagram	15
2	Applications	1	8.3	Feature Description	15
3	Description	1	8.4	Device Functional Modes	15
4	Revision History	2	9	Application and Implementation	16
5	Pin Configuration and Functions	3	9.1	Application Information	16
6	Specifications	4	9.2	Typical Application	16
6.1	Absolute Maximum Ratings	4	10	Power Supply Recommendations	18
6.2	ESD Ratings	4	11	Layout	18
6.3	Recommended Operating Conditions	4	11.1	Layout Guidelines	18
6.4	Thermal Information	5	11.2	Layout Example	18
6.5	Electrical Characteristics for 2.5-V Supply	5	12	Device and Documentation Support	19
6.6	Electrical Characteristics for 3.3-V Supply	6	12.1	Receiving Notification of Documentation Updates	19
6.7	Electrical Characteristics for 5-V Supply	7	12.2	Community Resources	19
6.8	Typical Characteristics	9	12.3	Trademarks	19
7	Parameter Measurement Information	11	12.4	Electrostatic Discharge Caution	19
8	Detailed Description	15	12.5	Glossary	19
8.1	Overview	15	13	Mechanical, Packaging, and Orderable Information	19

4 Revision History

NOTE: Page numbers for previous revisions may differ from page numbers in the current version.

Changes from Revision C (June 2017) to Revision D	Page
• Changed the YZP Package From: Laser Marketing View and Bump View To: Top View	3
• Changed the Q_C TYP value From: 10 pC To: 150 pC in the <i>Electrical Characteristics for 5-V Supply</i> table	8
Changes from Revision B (September 2015) to Revision C	Page
• Changed the V_{IN} MAX value From: V_{CC} To: 5.5 V in the <i>Recommended Operating Conditions</i> table	4
Changes from Revision A (August 2015) to Revision B	Page
• Changed C_L TEST CONDITION value for all THD PARAMETERS from 15 pf to 35 pf.	6
Changes from Original (June 2015) to Revision A	Page
• Changed the Functional Block Diagram.	15

5 Pin Configuration and Functions

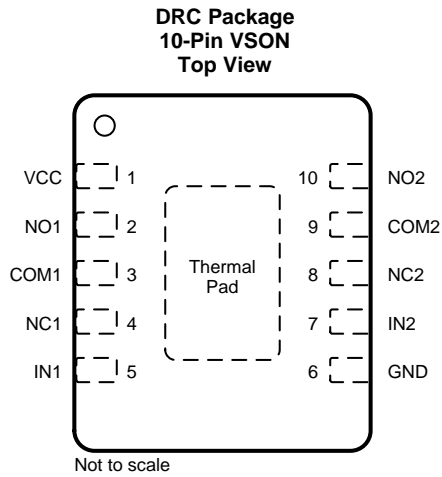

The exposed center pad, if used, must be connected as a secondary GND or left electrically open.

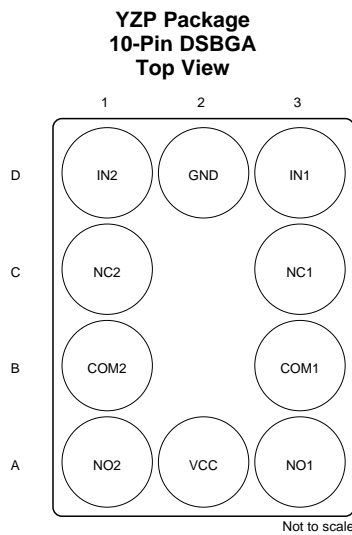
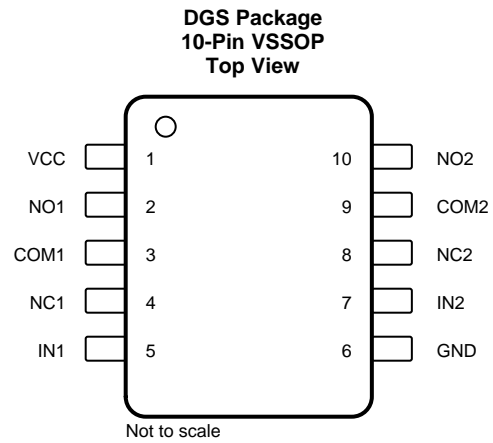

Pin Functions

NAME	PIN			TYPE	DESCRIPTION
	VSON	VSSOP	DSBGA		
VCC	1	1	A2	—	Power Supply
NO1	2	2	A3	I/O	Normally Open (NO) signal path, Switch 1
COM1	3	3	B3	I/O	Common signal path, Switch 1
NC1	4	4	C3	I/O	Normally Closed (NC) signal path, Switch 1
IN1	5	5	D3	I	Digital control pin , Switch 1
GND	6	6	D2	—	Ground
IN2	7	7	D1	I	Digital control pin, Switch 2
NC2	8	8	C1	I/O	Normally Closed (NC) signal path, Switch 2
COM2	9	9	B1	I/O	Common signal path, Switch 2
NO2	10	10	A1	I/O	Normally Open (NO) signal Path, Switch 2

6 Specifications

6.1 Absolute Maximum Ratings

 over operating free-air temperature range (unless otherwise noted) ⁽¹⁾

		MIN	MAX	UNIT
V_{CC} ⁽²⁾	Supply voltage ⁽³⁾	-0.5	6	V
V_{NC} V_{NO} V_{COM}	Analog voltage ⁽³⁾ ⁽⁴⁾ ⁽⁵⁾	$V_{CC} - 6$	$V_{CC} + 0.5$	V
$I_{I/OK}$	Analog port diode current $V_{NC}, V_{NO}, V_{COM} < 0$ or $V_{NC}, V_{NO}, V_{COM} > V_{CC}$	-50	50	mA
I_{NC} I_{NO} I_{COM}	ON-state switch current ON-state peak switch current ⁽⁶⁾	-150 -300	150 300	mA
I_{NC} ⁽³⁾ ⁽⁷⁾ ⁽⁸⁾ I_{NO} ⁽³⁾ ⁽⁷⁾ ⁽⁸⁾ I_{COM} ⁽³⁾ ⁽⁷⁾ ⁽⁸⁾	ON-state switch current ON-state peak switch current ⁽⁶⁾	-350 -500	350 500	mA
V_I	Digital input voltage	-0.5	6.5	V
I_{IK}	Digital input clamp current ⁽³⁾ ⁽⁴⁾ $V_I < 0$	-50	50	mA
I_{CC} I_{GND}	Continuous current through V_{CC} or GND	-100	100	mA
T_{stg}	Storage temperature	-65	150	°C

- (1) Stresses beyond those listed under *Absolute Maximum Ratings* may cause permanent damage to the device. These are stress ratings only, which do not imply functional operation of the device at these or any other conditions beyond those indicated under *Recommended Operating Conditions*. Exposure to absolute-maximum-rated conditions for extended periods may affect device reliability.
- (2) The algebraic convention, whereby the most negative value is a minimum and the most positive value is a maximum
- (3) All voltages are with respect to ground, unless otherwise specified.
- (4) The input and output voltage ratings may be exceeded if the input and output clamp-current ratings are observed.
- (5) This value is limited to 5.5 V maximum.
- (6) Pulse at 1-ms duration < 10% duty cycle.
- (7) $V_{CC} = 3.0$ V to 5.0 V, $T_A = -40$ °C to 85°C.
- (8) For YZP package only.

6.2 ESD Ratings

		VALUE	UNIT
$V_{(ESD)}$ Electrostatic discharge	Human-body model (HBM), per ANSI/ESDA/JEDEC JS-001 ⁽¹⁾	±2500	V
	Charged-device model (CDM), per JEDEC specification JESD22-C101 ⁽²⁾	±1500	

- (1) JEDEC document JEP155 states that 500-V HBM allows safe manufacturing with a standard ESD control process.
- (2) JEDEC document JEP157 states that 250-V CDM allows safe manufacturing with a standard ESD control process.

6.3 Recommended Operating Conditions

over operating free-air temperature range (unless otherwise noted)

		MIN	MAX	UNIT
V_{CC}	Supply voltage	2.3	5.5	V
V_{NC} V_{NO} V_{COM}	Signal path voltage	$V_{CC} - 5.5$	V_{CC}	V
V_{IN}	Digital control	GND	5.5	V

6.4 Thermal Information

THERMAL METRIC ⁽¹⁾		TS5A22362			UNIT
		DGS (VSSOP)	DRC (VSON)	YZP (DSBGA)	
		10 PINS	10 PINS	10 PINS	
R _{θJA}	Junction-to-ambient thermal resistance	163.3	44.3	90.9	°C/W
R _{θJC(top)}	Junction-to-case (top) thermal resistance	56.4	70.1	0.3	°C/W
R _{θJB}	Junction-to-board thermal resistance	83.1	19.3	8.3	°C/W
ψ _{JT}	Junction-to-top characterization parameter	6.8	2.0	3.2	°C/W
ψ _{JB}	Junction-to-board characterization parameter	81.8	19.4	8.3	°C/W

(1) For more information about traditional and new thermal metrics, see the [Semiconductor and IC Package Thermal Metrics](#) application report.

6.5 Electrical Characteristics for 2.5-V Supply

V_{CC} = 2.3 V to 2.7 V, T_A = –40°C to 85°C (unless otherwise noted) ⁽¹⁾

PARAMETER		TEST CONDITIONS		T _A	V _{CC}	MIN	TYP	MAX	UNIT
Analog Switch									
V _{COM} , V _{NO} , V _{NC}	Analog signal range					V _{CC} – 5.5		V _{CC}	V
R _{on}	ON-state resistance	V _{NC} or V _{NO} = V _{CC} , 1.5 V, V _{CC} – 5.5 V I _{COM} = –100 mA,	COM to NO or NC, see Figure 13	25°C Full	2.7 V	0.65	0.94	1.3	Ω
ΔR _{on}	ON-state resistance match between channels	V _{NC} or V _{NO} = 1.5 V, I _{COM} = –100 mA,	COM to NO or NC, see Figure 13	25°C Full	2.7 V	0.023	0.11	0.15	Ω
R _{on(flat)}	ON-state resistance flatness	V _{NC} or V _{NO} = V _{CC} , 1.5 V, V _{CC} – 5.5 V I _{COM} = –100 mA,	COM to NO or NC, see Figure 13	25°C Full	2.7 V	0.18	0.46	0.5	Ω
I _{NC(OFF)} , I _{NO(OFF)}	NC, NO OFF leakage current	V _{NC} = 2.25 V, V _{CC} – 5.5 V V _{COM} = V _{CC} – 5.5 V, 2.25 V V _{NO} = Open COM to NO or V _{NO} = 2.25 V, V _{CC} – 5.5 V, V _{COM} = V _{CC} – 5.5 V, 2.25 V V _{NC} = Open COM to NC	See Figure 14	25°C Full	2.7 V	–50		50	nA
I _{COM(ON)}	COM ON leakage current	V _{NC} and V _{NO} = Floating, V _{COM} = V _{CC} , V _{CC} – 5.5 V	See Figure 15	25°C Full	2.7 V	–50		50	nA
Digital Control Inputs (IN) ⁽²⁾									
V _{IH}	Input logic high			Full		1.4		5.5	V
V _{IL}	Input logic low							0.6	
I _{IH} , I _{IL}	Input leakage current	V _{IN} = V _{CC} or 0		25°C Full	2.7 V	–250		250	nA
Dynamic									
t _{ON}	Turnon time	V _{COM} = V _{CC} , R _L = 300 Ω,	C _L = 35 pF, see Figure 17	25°C Full	2.5 V 2.3 V to 2.7 V		44	80	ns
t _{OFF}	Turnoff time	V _{COM} = V _{CC} , R _L = 300 Ω,	C _L = 35 pF, see Figure 17	25°C Full	2.5 V 2.3 V to 2.7 V		22	70	ns
t _{BBM}	Break-before-make time	See Figure 18		25°C	2.5 V	1	7		ns
Q _C	Charge injection	V _{GEN} = 0, R _{GEN} = 0,	C _L = 1 nF, see Figure 22	25°C	2.5 V		150		pC
C _{NC(OFF)} , C _{NO(OFF)}	NC, NO OFF capacitance	V _{NC} or V _{NO} = V _{CC} or GND,	See Figure 16	25°C	2.5 V		70		pF

(1) The algebraic convention, whereby the most negative value is a minimum and the most positive value is a maximum

(2) All unused digital inputs of the device must be held at V_{CC} or GND to ensure proper device operation. Refer to the TI application report, [Implications of Slow or Floating CMOS Inputs, SCBA004](#).

Electrical Characteristics for 2.5-V Supply (continued)

 $V_{CC} = 2.3 \text{ V to } 2.7 \text{ V}$, $T_A = -40^\circ\text{C to } 85^\circ\text{C}$ (unless otherwise noted) ⁽¹⁾

PARAMETER	TEST CONDITIONS	T_A	V_{CC}	MIN	TYP	MAX	UNIT
$C_{COM(ON)}$	NC, NO, COM ON capacitance $V_{COM} = V_{CC}$ or GND, Switch ON, $f = 10 \text{ MHz}$	See Figure 16	25°C	2.5 V	370		pF
C_i	Digital input capacitance $V_i = V_{CC}$ or GND	See Figure 16	25°C	2.5 V	2.6		pF
BW	Bandwidth $R_L = 50 \Omega$, -3 dB	See Figure 18	25°C	2.5 V	17		MHz
O_{ISO}	OFF isolation $R_L = 50 \Omega$	$f = 100 \text{ kHz}$, see Figure 20	25°C	2.5 V	-66		dB
X_{TALK}	Crosstalk $R_L = 50 \Omega$	$f = 100 \text{ kHz}$, see Figure 21	25°C	2.5 V	-75		dB
THD	Total harmonic distortion $R_L = 600 \Omega$, $C_L = 35 \text{ pF}$	$f = 20 \text{ Hz to } 20 \text{ kHz}$, see Figure 23	25°C	2.5 V	0.01%		
Supply							
I_{CC}	Positive supply current V_{COM} and $V_{IN} = V_{CC}$ or GND, V_{NC} and $V_{NO} = \text{Floating}$	25°C	2.7 V	0.2	1.1		μA
		Full		1.3			
I_{CC}	Positive supply current $V_{COM} = V_{CC} - 5.5 \text{ V}$, $V_{IN} = V_{CC}$ or GND, V_{NC} and $V_{NO} = \text{Floating}$	Full	2.7 V			3.3	μA

6.6 Electrical Characteristics for 3.3-V Supply

 $V_{CC} = 3 \text{ V to } 3.6 \text{ V}$, $T_A = -40^\circ\text{C to } 85^\circ\text{C}$ (unless otherwise noted) ⁽¹⁾

PARAMETER	TEST CONDITIONS	T_A	V_{CC}	MIN	TYP	MAX	UNIT
ANALOG SWITCH							
V_{COM} , V_{NO} , V_{NC}	Analog signal range			$V_{CC} - 5.5$		V_{CC}	V
R_{on}	ON-state resistance V_{NC} or $V_{NO} \leq V_{CC}$, 1.5 V, $V_{CC} - 5.5 \text{ V}$, $I_{COM} = -100 \text{ mA}$	25°C	3 V	0.61	0.87		Ω
		Full		0.97			
ΔR_{on}	ON-state resistance match between channels V_{NC} or $V_{NO} = 1.5 \text{ V}$, $I_{COM} = -100 \text{ mA}$	25°C	3 V	0.024	0.13		Ω
		Full		0.13			
$R_{on(Flat)}$	ON-state resistance flatness V_{NC} or $V_{NO} \leq V_{CC}$, 1.5 V, $V_{CC} - 5.5 \text{ V}$, $I_{COM} = -100 \text{ mA}$	25°C	3 V	0.12	0.46		Ω
		Full		0.5			
$I_{NC(OFF)}$, $I_{NO(OFF)}$	NC, NO OFF leakage current $V_{NC} = 3 \text{ V}$, $V_{CC} - 5.5 \text{ V}$ $V_{COM} = V_{CC} - 5.5 \text{ V}$, 3 V $V_{NO} = \text{Open}$ COM to NO or $V_{NO} = 3 \text{ V}$, $V_{CC} - 5.5 \text{ V}$, $V_{COM} = V_{CC} - 5.5 \text{ V}$, 3 V $V_{NC} = \text{Open}$ COM to NC	25°C	3.6 V	-50		50	nA
		Full		-375		375	
$I_{COM(ON)}$	COM ON leakage current V_{NC} and $V_{NO} = \text{Floating}$, $V_{COM} = V_{CC}$, $V_{CC} - 5.5 \text{ V}$	25°C	3.6 V	-50		50	nA
		Full		-375		375	
DIGITAL CONTROL INPUTS (IN) ⁽²⁾							
V_{IH}	Input logic high	Full		1.4		5.5	V
V_{IL}	Input logic low					0.8	
I_{IH} , I_{IL}	Input leakage current $V_{IN} = V_{CC}$ or 0	25°C	3.6 V	-250		250	nA
		Full		-250		250	

(1) The algebraic convention, whereby the most negative value is a minimum and the most positive value is a maximum

(2) All unused digital inputs of the device must be held at V_{CC} or GND to ensure proper device operation. Refer to the TI application report, *Implications of Slow or Floating CMOS Inputs*, literature number [SCBA004](#).

Electrical Characteristics for 3.3-V Supply (continued)

 $V_{CC} = 3\text{ V to }3.6\text{ V}$, $T_A = -40^\circ\text{C to }85^\circ\text{C}$ (unless otherwise noted) ⁽¹⁾

PARAMETER		TEST CONDITIONS		T_A	V_{CC}	MIN	TYP	MAX	UNIT
DYNAMIC									
t_{ON}	Turnon time	$V_{COM} = V_{CC}$, $R_L = 300\ \Omega$	$C_L = 35\text{ pF}$, see Figure 17	25°C	3.3 V		34	80	ns
				Full	3 V to 3.6 V			120	
t_{OFF}	Turnoff time	$V_{COM} = V_{CC}$, $R_L = 300\ \Omega$	$C_L = 35\text{ pF}$, see Figure 17	25°C	3.3 V		19	70	ns
				Full	3 V to 3.6 V			70	
t_{BBM}	Break-before-make time	See Figure 18		25°C	3.3 V	1	7		ns
Q_C	Charge injection	$V_{GEN} = 0$, $R_{GEN} = 0$	$C_L = 1\text{ nF}$, see Figure 22	25°C	3.3 V		150		pC
$C_{NC(OFF)}$, $C_{NO(OFF)}$	NC, NO OFF capacitance	V_{NC} or $V_{NO} = V_{CC}$ or $V_{CC} - 5.5\text{ V}$	See Figure 16	25°C	3.3 V		70		pF
$C_{COM(ON)}$	NC, NO, COM ON capacitance	$V_{COM} = V_{CC}$ or GND, $f = 10\text{ MHz}$	See Figure 16	25°C	3.3 V		370		pF
C_I	Digital input capacitance	$V_I = V_{CC}$ or GND	See Figure 16	25°C	3.3 V		2.6		pF
BW	Bandwidth	$R_L = 50\ \Omega$, -3 dB	Switch ON, see Figure 18	25°C	3.3 V		17.5		MHz
O_{ISO}	OFF isolation	$R_L = 50\ \Omega$	$f = 100\text{ kHz}$, see Figure 20	25°C	3.3 V		-68		dB
X_{TALK}	Crosstalk	$R_L = 50\ \Omega$	$f = 100\text{ kHz}$, see Figure 21	25°C	3.3 V		-76		dB
THD	Total harmonic distortion	$R_L = 600\ \Omega$, $C_L = 35\text{ pF}$	$f = 20\text{ Hz to }20\text{ kHz}$, see Figure 23	25°C	3.3 V		0.008%		
SUPPLY									
I_{CC}	Positive supply current	V_{COM} and $V_{IN} = V_{CC}$ or GND, V_{NC} and $V_{NO} = \text{Floating}$		25°C	3.6 V		0.1	1.2	μA
				Full				1.3	
		$V_{COM} = V_{CC} - 5.5\text{ V}$, $V_{IN} = V_{CC}$ or GND, V_{NC} and $V_{NO} = \text{Floating}$		Full	3.6 V			3.4	μA

6.7 Electrical Characteristics for 5-V Supply

 $V_{CC} = 4.5\text{ V to }5.5\text{ V}$, $T_A = -40^\circ\text{C to }85^\circ\text{C}$ (unless otherwise noted) ⁽¹⁾

PARAMETER		TEST CONDITIONS		T_A	V_{CC}	MIN	TYP	MAX	UNIT
ANALOG SWITCH									
V_{COM} , V_{NO} , V_{NC}	Analog signal range					$V_{CC} - 5.5$		V_{CC}	V
R_{on}	ON-state resistance	V_{NC} or $V_{NO} = V_{CC}$, 1.6 V, $V_{CC} = -5.5\text{ V}$, $I_{COM} = -100\text{ mA}$	COM to NO or NC, see Figure 13	25°C	4.5 V		0.52	0.74	Ω
				Full				0.83	
ΔR_{on}	ON-state resistance match between channels	V_{NC} or $V_{NO} = 1.6\text{ V}$, $I_{COM} = -100\text{ mA}$	COM to NO or NC, see Figure 13	25°C	4.5 V		0.04	0.23	Ω
				Full				0.30	
$R_{on(Flat)}$	ON-state resistance flatness	V_{NC} or $V_{NO} = V_{CC}$, 1.6 V, $V_{CC} = -5.5\text{ V}$, $I_{COM} = -100\text{ mA}$	COM to NO or NC, see Figure 13	25°C	4.5 V		0.076	0.46	Ω
				Full				0.5	
$I_{NC(OFF)}$, $I_{NO(OFF)}$	NC, NO OFF leakage current	$V_{NC} = 4.5\text{ V}$, $V_{CC} - 5.5\text{ V}$, $V_{COM} = V_{CC} - 5.5\text{ V}$, 4.5 V, $V_{NO} = \text{Open}$, COM to NO or $V_{NO} = 4.5\text{ V}$, $V_{CC} - 5.5\text{ V}$, $V_{COM} = V_{CC} - 5.5\text{ V}$, 4.5 V, $V_{NC} = \text{Open}$, COM to NC	See Figure 14	25°C	5.5 V		-50	50	nA
				Full				-375	
$I_{COM(ON)}$	COM ON leakage current	V_{NC} and $V_{NO} = \text{Floating}$, $V_{COM} = V_{CC}$, $V_{CC} - 5.5\text{ V}$	See Figure 15	25°C	5.5 V		-50	50	nA
				Full				-375	

(1) The algebraic convention, whereby the most negative value is a minimum and the most positive value is a maximum

Electrical Characteristics for 5-V Supply (continued)
 $V_{CC} = 4.5 \text{ V to } 5.5 \text{ V}$, $T_A = -40^\circ\text{C to } 85^\circ\text{C}$ (unless otherwise noted) ⁽¹⁾

PARAMETER		TEST CONDITIONS		T_A	V_{CC}	MIN	TYP	MAX	UNIT
DIGITAL CONTROL INPUTS (IN) ⁽²⁾									
V_{IH}	Input logic high			Full		2.4		5.5	V
V_{IL}	Input logic low							0.8	
I_{IH}, I_{IL}	Input leakage current	$V_{IN} = V_{CC} \text{ or } 0$			25°C	5.5 V	-250	250	nA
					Full		-250	250	
DYNAMIC									
t_{ON}	Turnon time	$V_{COM} = V_{CC}$, $R_L = 300 \Omega$	$C_L = 35 \text{ pF}$, see Figure 17	25°C	5 V		27	80	ns
				Full	4.5 V to 5.5 V			80	
t_{OFF}	Turnoff time	$V_{COM} = V_{CC}$, $R_L = 300 \Omega$	$C_L = 35 \text{ pF}$, see Figure 17	25°C	5 V		13	70	ns
				Full	4.5 V to 5.5 V			70	
t_{BBM}	Break-before-make time	$V_{NC} = V_{NO} = V_{CC}/2$ $R_L = 300 \Omega$	$C_L = 35 \text{ pF}$, see Figure 18	25°C	5 V	1	3.5		ns
Q_C	Charge injection	$V_{GEN} = 0$, $R_{GEN} = 0$	$C_L = 1 \text{ nF}$, see Figure 22	25°C	5 V		150		pC
$C_{NC(OFF)}, C_{NO(OFF)}$	NC, NO OFF capacitance	$V_{NC} \text{ or } V_{NO} = V_{CC} \text{ or } V_{CC} - 5.5 \text{ V}$	See Figure 16	25°C	5 V		70		pF
$C_{COM(ON)}$	NC, NO, COM ON capacitance	$V_{COM} = V_{CC} \text{ or } GND$,	See Figure 16	25°C	5 V		370		pF
C_I	Digital input capacitance	$V_I = V_{CC} \text{ or } GND$	See Figure 16	25°C	5 V		2.6		pF
BW	Bandwidth	$R_L = 50 \Omega$	See Figure 18	25°C	5 V		18.3		MHz
O_{ISO}	OFF isolation	$R_L = 50 \Omega$	$f = 100 \text{ kHz}$, see Figure 20	25°C	5 V		-70		dB
X_{TALK}	Crosstalk	$R_L = 50 \Omega$	$f = 100 \text{ kHz}$, see Figure 21	25°C	5 V		-78		dB
THD	Total harmonic distortion	$R_L = 600 \Omega$, $C_L = 35 \text{ pF}$	$f = 20 \text{ Hz to } 20 \text{ kHz}$, see Figure 23	25°C	5 V		0.009%		
SUPPLY									
I_{CC}	Positive supply current	$V_{COM} \text{ and } V_{IN} = V_{CC} \text{ or } GND$, $V_{NC} \text{ and } V_{NO} = \text{Floating}$			25°C	5.5 V	0.2	1.3	μA
					Full		3.5		
				$V_{COM} = V_{CC} - 5.5 \text{ V}$, $V_{IN} = V_{CC} \text{ or } GND$, $V_{NC} \text{ and } V_{NO} = \text{Floating}$			Full	5	

(2) All unused digital inputs of the device must be held at V_{CC} or GND to ensure proper device operation. Refer to the TI application report, *Implications of Slow or Floating CMOS Inputs*, [SCBA004](#).

6.8 Typical Characteristics

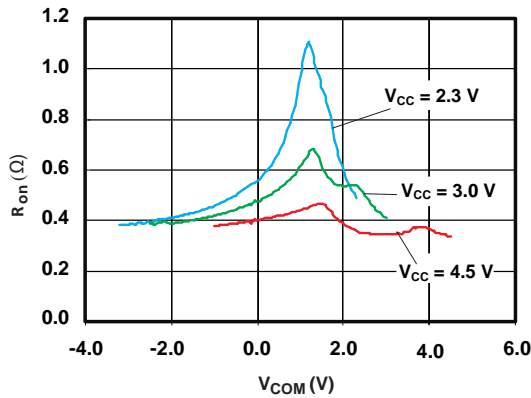

Figure 1. R_{on} vs V_{COM}

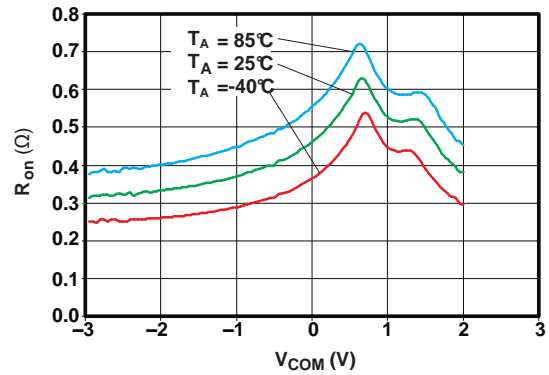

Figure 2. R_{on} vs V_{COM} ($V_{CC} = 2.7\text{ V}$)

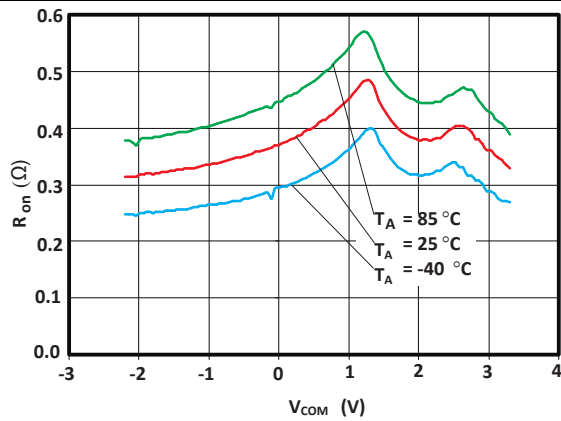

Figure 3. R_{on} vs V_{COM} ($V_{CC} = 3.3\text{ V}$)

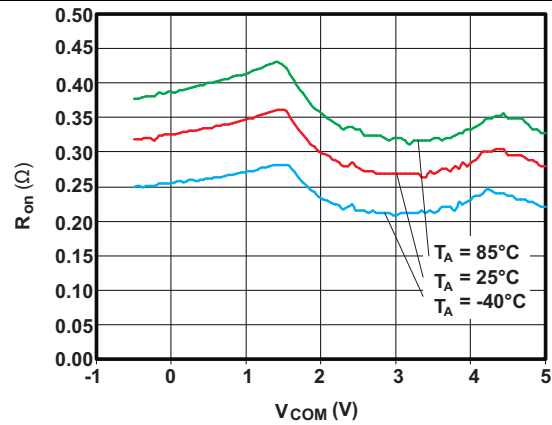

Figure 4. R_{on} vs V_{COM} ($V_{CC} = 5\text{ V}$)

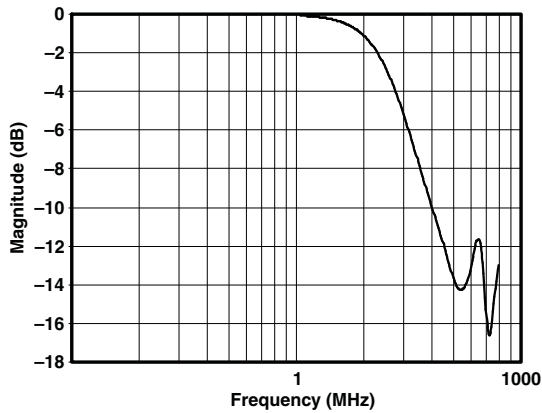

Figure 5. Insertion Loss

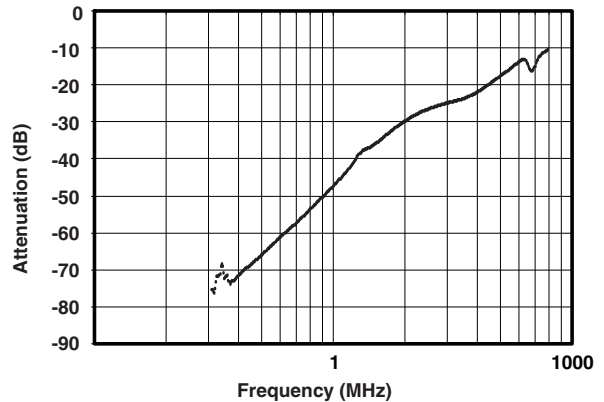

Figure 6. Off Isolation vs Frequency

Typical Characteristics (continued)

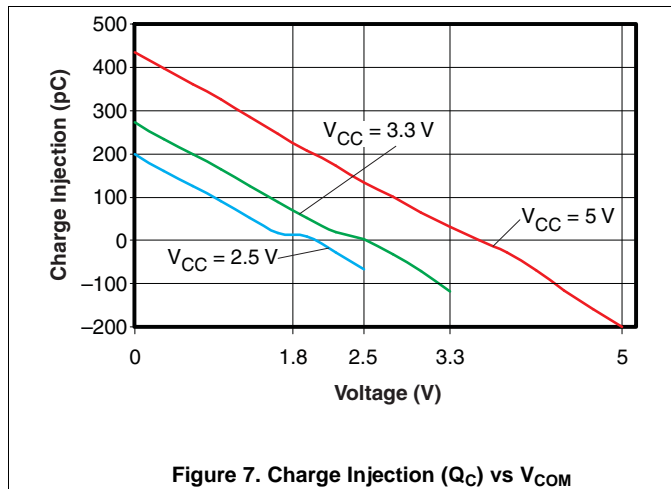

Figure 7. Charge Injection (Q_C) vs V_{COM}

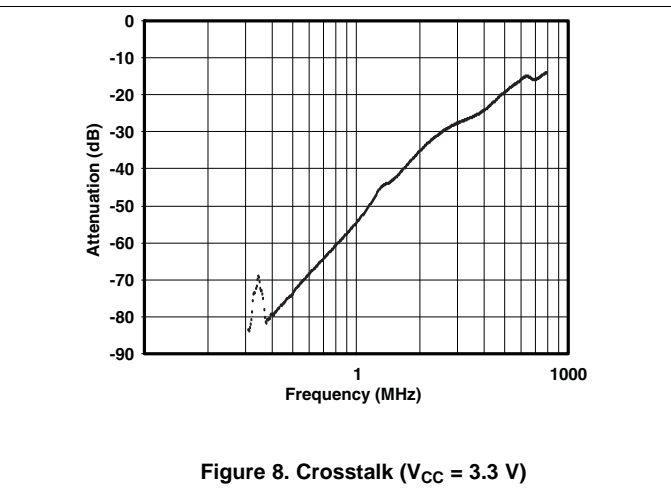

Figure 8. Crosstalk ($V_{CC} = 3.3\text{ V}$)

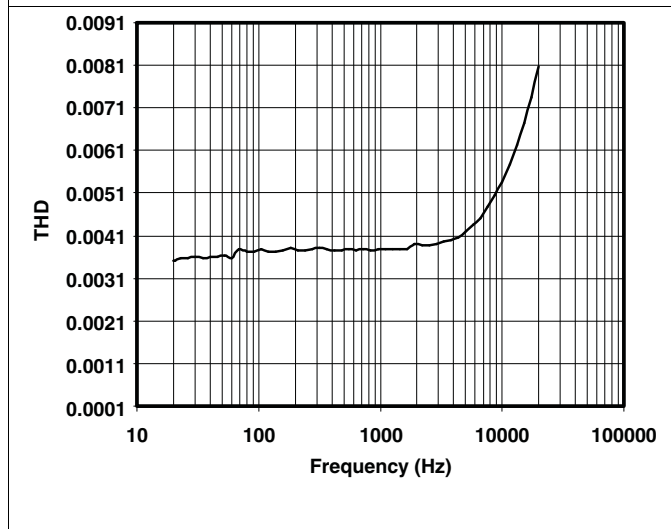

Figure 9. Total Harmonic Distortion vs Frequency

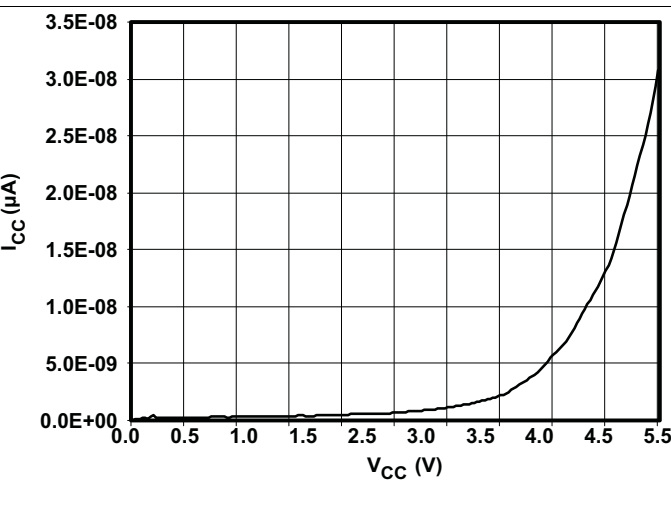

Figure 10. Power-Supply Current vs V_{CC}

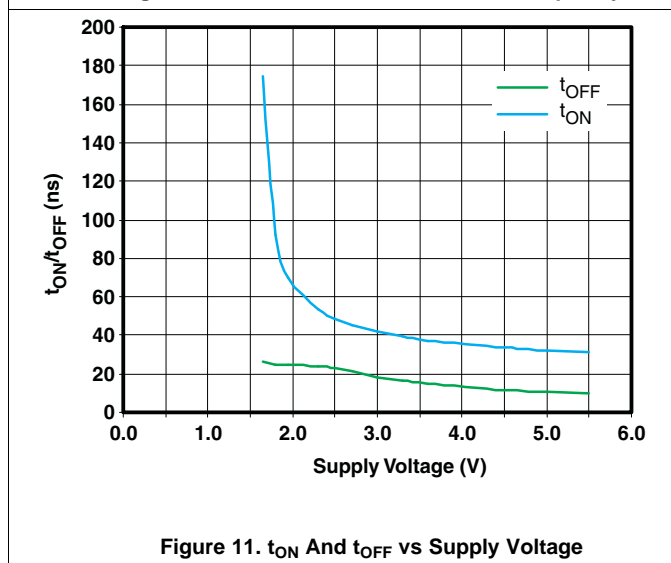

Figure 11. t_{ON} And t_{OFF} vs Supply Voltage

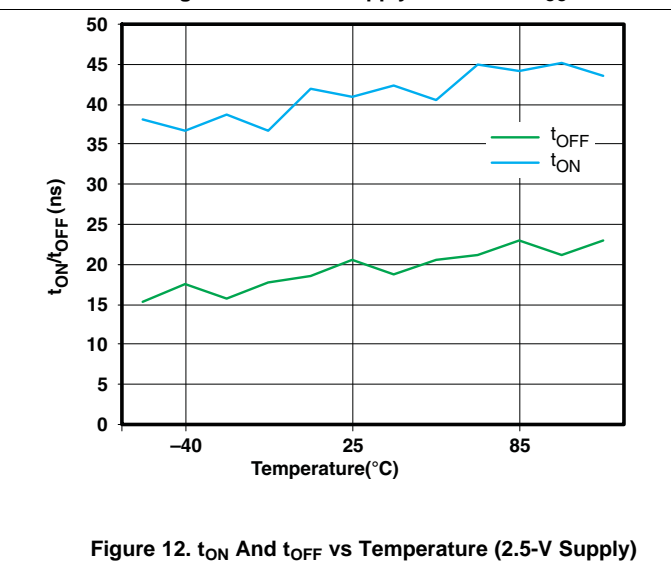

Figure 12. t_{ON} And t_{OFF} vs Temperature (2.5-V Supply)

7 Parameter Measurement Information

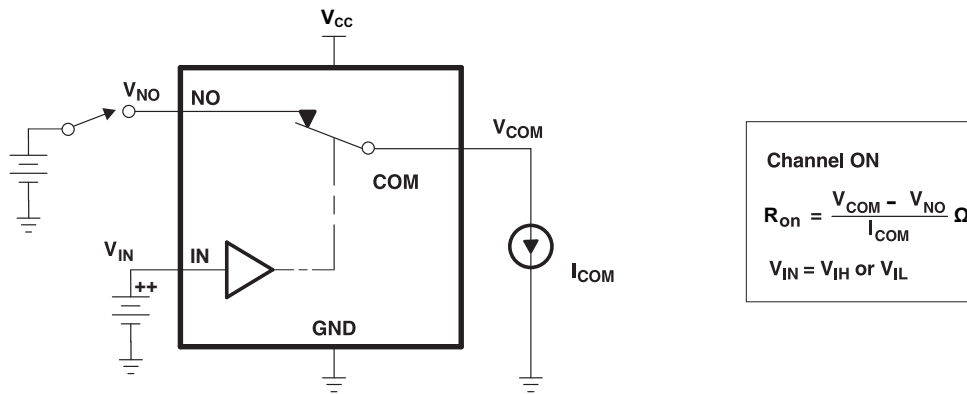

Figure 13. ON-state resistance (R_{on})

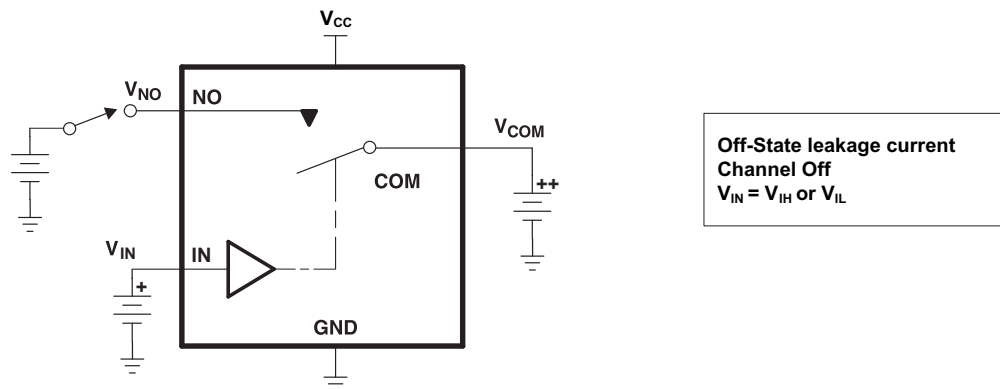

Figure 14. OFF-state leakage current ($I_{COM(OFF)}$, $I_{NO(OFF)}$)

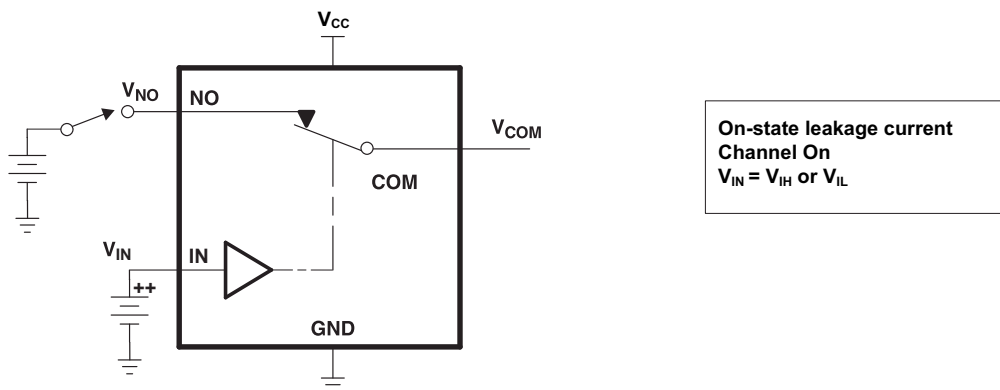

Figure 15. ON-state leakage current ($I_{COM(ON)}$, $I_{NO(ON)}$)

Parameter Measurement Information (continued)

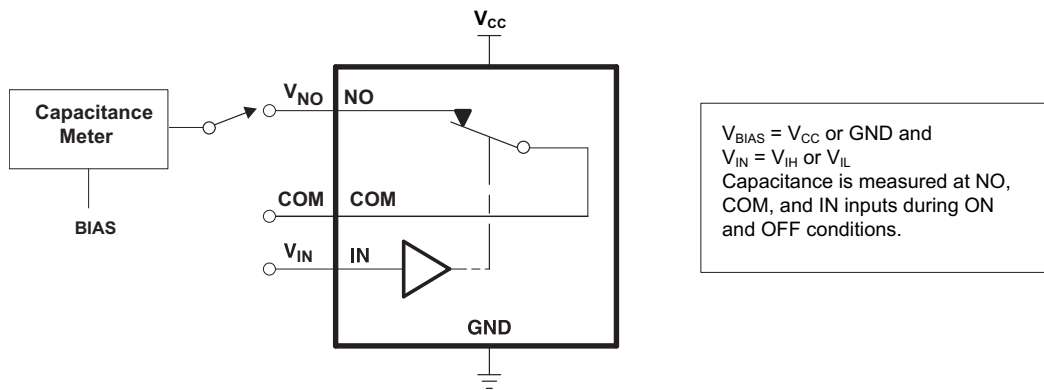
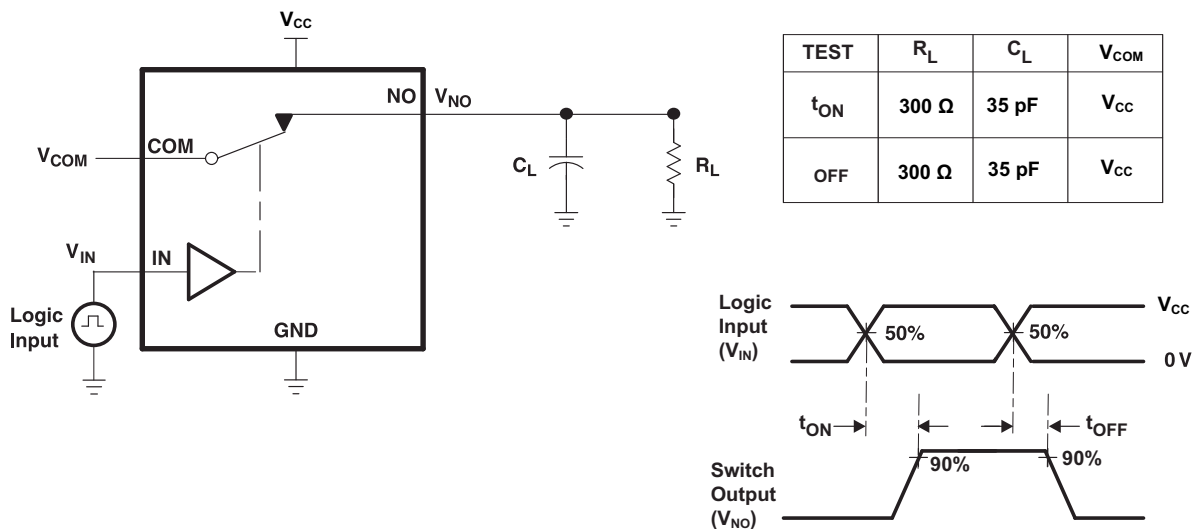

Figure 16. Capacitance (C_I , $C_{COM(OFF)}$, $C_{COM(ON)}$, $C_{NO(OFF)}$, $C_{NO(ON)}$)



- A. All input pulses are supplied by generators having the following characteristics: PRR \leq 10 MHz, $Z_O = 50 \Omega$, $t_r < 5$ ns,
- B. C_L includes probe and jig capacitance.

Figure 17. Turnon (t_{ON}) and Turnoff time (t_{OFF})

Parameter Measurement Information (continued)

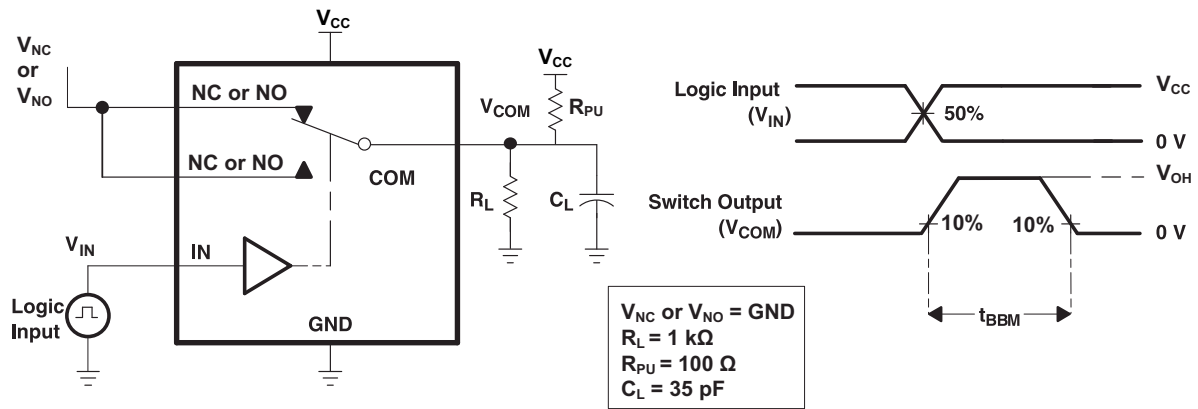

- A. C_L includes probe and jig capacitance.
- B. All input pulses are supplied by generators having the following characteristics: PRR \leq 10 MHz, $Z_O = 50\ \Omega$, $t_r < 5\text{ ns}$, $t_f < 5\text{ ns}$.

Figure 18. Break-Before-Make Time (t_{BBM})

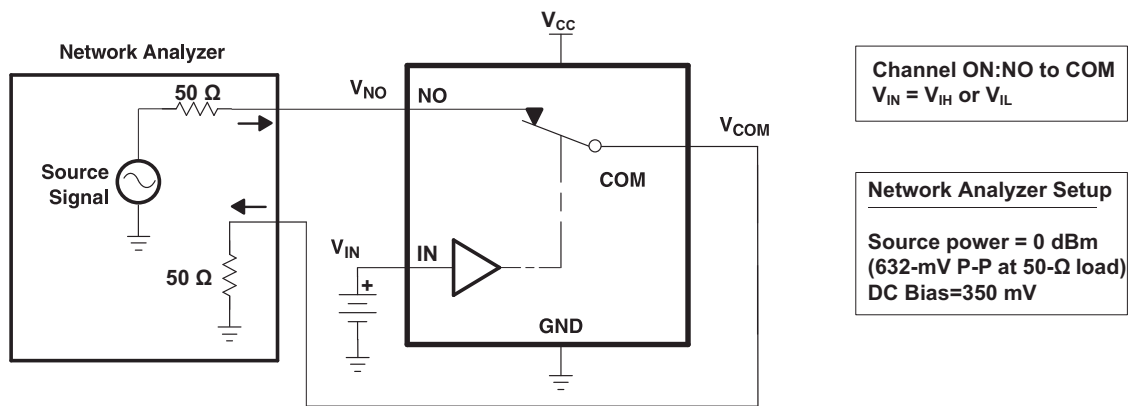

Figure 19. Bandwidth (BW)

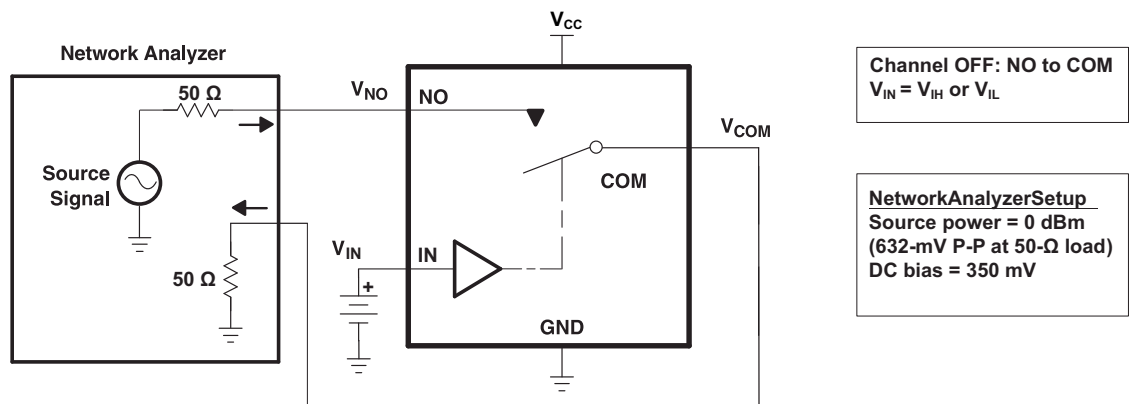

Figure 20. OFF isolation (O_{ISO})

Parameter Measurement Information (continued)

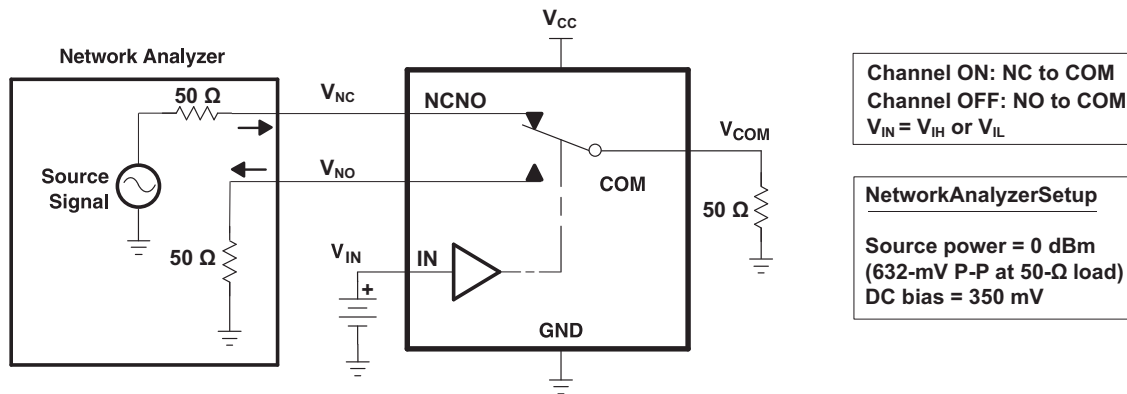
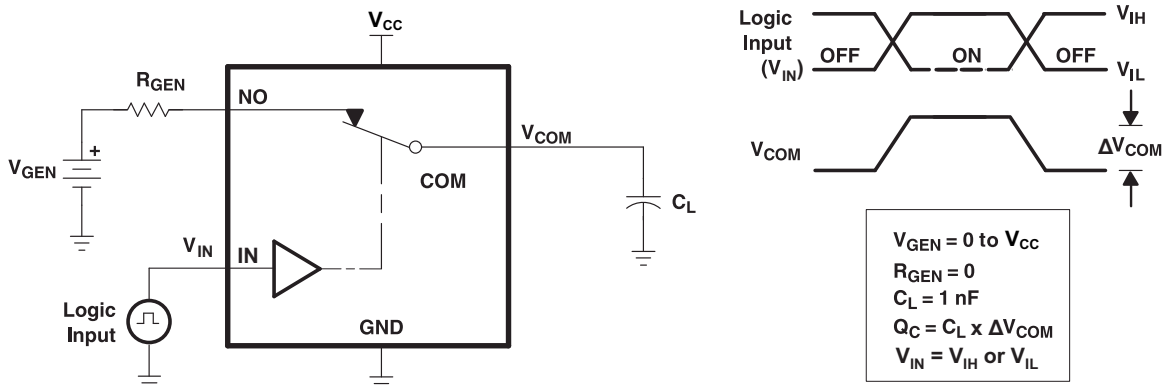

Figure 21. Crosstalk (X_{TALK})



- A. All input pulses are supplied by generators having the following characteristics: $PRR \leq 10$ MHz, $Z_0 = 50 \Omega$, $t_r < 5$ ns, $t_f < 5$ ns.
- B. C_L includes probe and jig capacitance.

Figure 22. Charge injection (Q_C)

Channel ON: COM to NO $V_{IN} = V_{IH}$ or V_{IL} $R_L = 600 \Omega$
 $V_{SOURCE} = 0.5$ V P-P $f_{SOURCE} = 20$ Hz to 20 kHz $C_L = 35$ pF

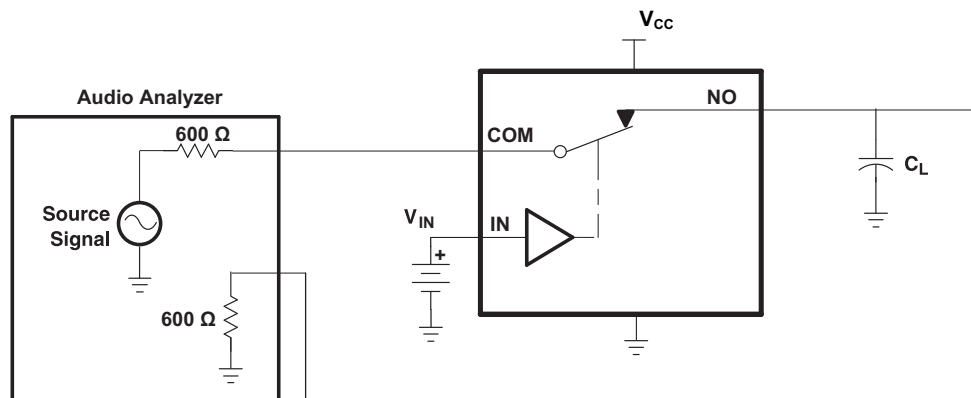

- A. C_L includes probe and jig capacitance.

Figure 23. Total Harmonic Distortion (THD)

8 Detailed Description

8.1 Overview

The TS5A22362 is a bidirectional, 2-channel single-pole double-throw (SPDT) analog switches designed to operate from 2.3 V to 5.5 V. The devices feature negative signal capability that allows signals below ground to pass through the switch without distortion. The break-before-make feature prevents signal distortion during the transferring of a signal from one path to another. Low ON-state resistance, excellent channel-to-channel ON-state resistance matching, and minimal total harmonic distortion (THD) performance are ideal for audio applications.

8.2 Functional Block Diagram

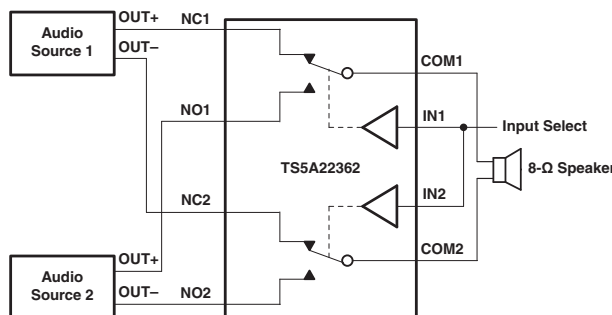

8.3 Feature Description

8.3.1 Negative Signaling Capacity

The TS5A22362 dual SPDT switches feature negative signal capability that allows signals below ground to pass through without distortion. These analog switches operate from a single +2.3-V to +5.5-V supply. The input and output signal swing of the device is dependant of the supply voltage V_{CC} : the devices pass signals as high as V_{CC} and as low as $V_{CC} - 5.5$ V, including signals below ground with minimal distortion.

Table 1 shows the input/output signal swing the user can get with different supply voltages.

Table 1. Input/Output signal swing

SUPPLY VOLTAGE, V_{CC}	MINIMUM (V_{NC}, V_{NO}, V_{COM}) = $V_{CC} - 5.5$	MAXIMUM (V_{NC}, V_{NO}, V_{COM}) = V_{CC}
5.5 V	0 V	5.5 V
4.5 V	-1.9 V	4.5 V
3.6 V	-2.5 V	3.6 V
3.0 V	-2.5 V	3.0 V
2.7 V	-2.8 V	2.7 V
2.3 V	-3.2 V	2.3 V

8.4 Device Functional Modes

The function table for TS5A22362 is shown in Table 2

Table 2. Function Table

IN	NC TO COM, COM TO NC	NO TO COM, COM TO NO
L	ON	OFF
H	OFF	ON

9 Application and Implementation

NOTE

Information in the following applications sections is not part of the TI component specification, and TI does not warrant its accuracy or completeness. TI's customers are responsible for determining suitability of components for their purposes. Customers should validate and test their design implementation to confirm system functionality.

9.1 Application Information

Ensure that the device is powered up with a supply voltage on VCC before a voltage can be applied to the signal paths NC and NO.

Tie the digitally controlled inputs select pins IN1 and IN2 to VCC or GND to avoid unwanted switch states that could result if the logic control pins are left floating.

All unused digital inputs of the device must be held at VCC or GND to ensure proper device operation. Refer to the TI application report, *Implications of Slow or Floating CMOS Inputs*, [SCBA004](#).

9.2 Typical Application

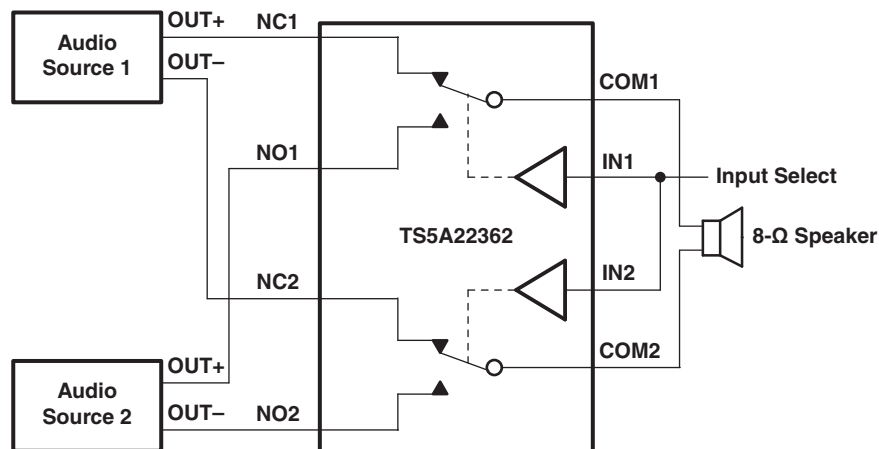

Figure 24. Typical Application

9.2.1 Design Requirements

Tie the digitally controlled inputs select pins IN1 and IN2 to VCC or GND to avoid unwanted switch states that could result if the logic control pins are left floating.

9.2.2 Detailed Design Procedure

Select the appropriate supply voltage to cover the entire voltage swing of the signal passing through the switch because the TS5A22362 operates from a single +2.3-V to +5.5-V supply and the input/output signal swing of the device is dependant of the supply voltage VCC. The device will pass signals as high as VCC and as low as VCC – 5.5 V. Use table 2 as a guide for selecting supply voltage based on the signal passing through the switch.

Ensure that the device is powered up with a supply voltage on VCC before a voltage can be applied to the signal paths NC and NO.

Typical Application (continued)

9.2.3 Application Curve

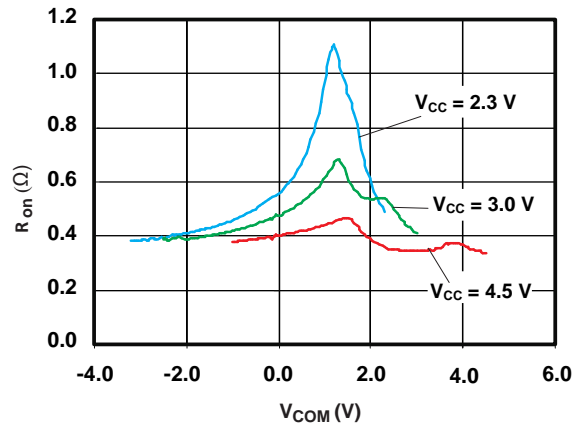

Figure 25. R_{on} vs V_{COM}

10 Power Supply Recommendations

The TS5A22362 operates from a single 2.3-V to 5.5-V supply. The device must be powered up with a supply voltage on VCC before a voltage can be applied to the signal paths NC and NO. It is recommended to include a 100- μ s delay after VCC is at voltage before applying a signal on NC and NO paths

It is also good practice to place a 0.1- μ F bypass capacitor on the supply pin VCC to GND to smooth out lower frequency noise to provide better load regulation across the frequency spectrum.

11 Layout

11.1 Layout Guidelines

TI recommends placing a bypass capacitor as close to the supply pin VCC as possible to help smooth out lower frequency noise to provide better load regulation across the frequency spectrum.

Minimize trace lengths and vias on the signal paths in order to preserve signal integrity.

11.2 Layout Example

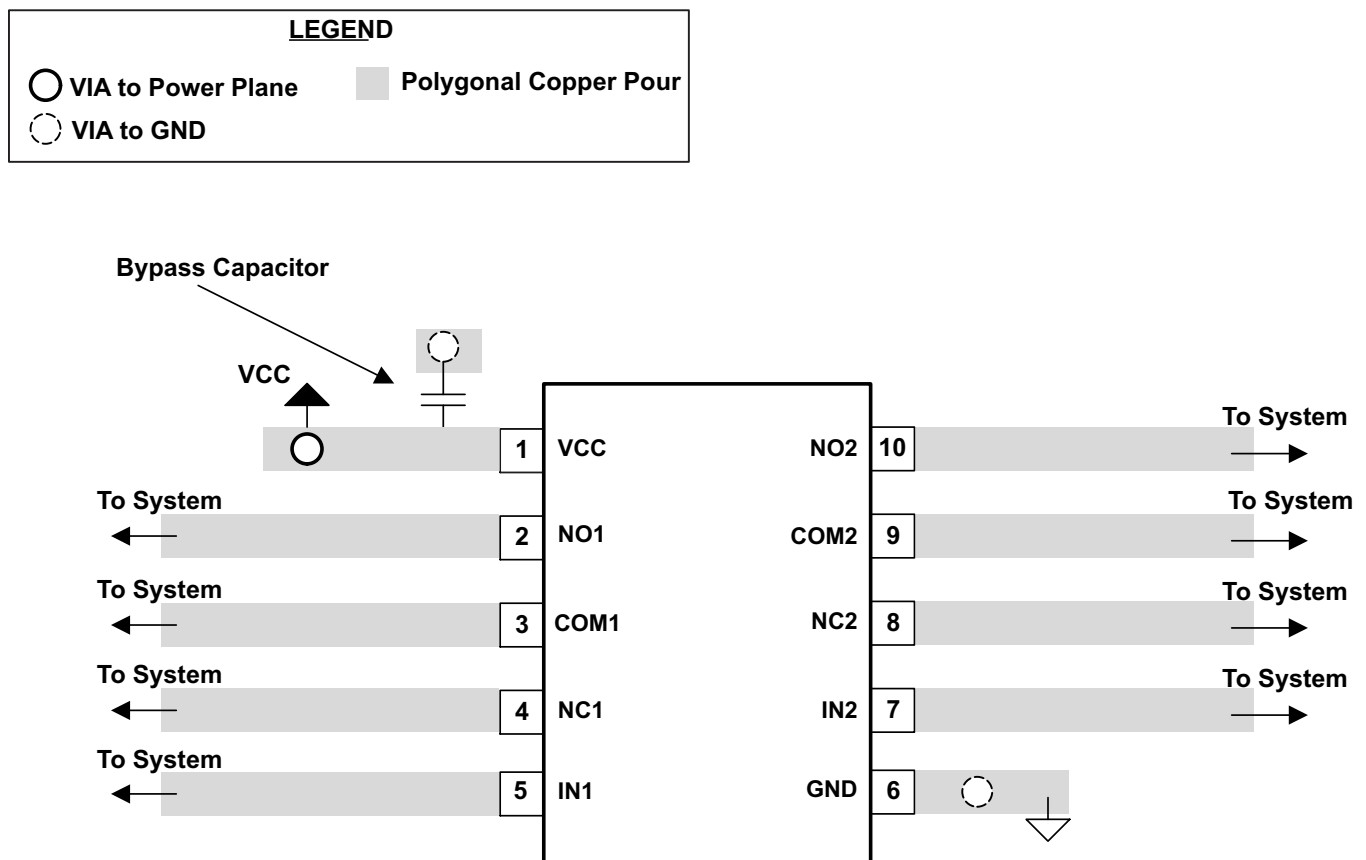

12 Device and Documentation Support

12.1 Receiving Notification of Documentation Updates

To receive notification of documentation updates, navigate to the device product folder on ti.com. In the upper right corner, click on *Alert me* to register and receive a weekly digest of any product information that has changed. For change details, review the revision history included in any revised document.

12.2 Community Resources

The following links connect to TI community resources. Linked contents are provided "AS IS" by the respective contributors. They do not constitute TI specifications and do not necessarily reflect TI's views; see TI's [Terms of Use](#).

TI E2E™ Online Community *TI's Engineer-to-Engineer (E2E) Community*. Created to foster collaboration among engineers. At e2e.ti.com, you can ask questions, share knowledge, explore ideas and help solve problems with fellow engineers.

Design Support *TI's Design Support* Quickly find helpful E2E forums along with design support tools and contact information for technical support.

12.3 Trademarks

E2E is a trademark of Texas Instruments.
All other trademarks are the property of their respective owners.

12.4 Electrostatic Discharge Caution



These devices have limited built-in ESD protection. The leads should be shorted together or the device placed in conductive foam during storage or handling to prevent electrostatic damage to the MOS gates.

12.5 Glossary

[SLYZ022](#) — *TI Glossary*.

This glossary lists and explains terms, acronyms, and definitions.

13 Mechanical, Packaging, and Orderable Information

The following pages include mechanical, packaging, and orderable information. This information is the most current data available for the designated devices. This data is subject to change without notice and revision of this document. For browser-based versions of this data sheet, refer to the left-hand navigation.

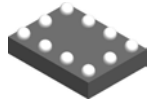

PACKAGE OUTLINE

YZP0010

DSBGA - 0.5 mm max height

DIE SIZE BALL GRID ARRAY

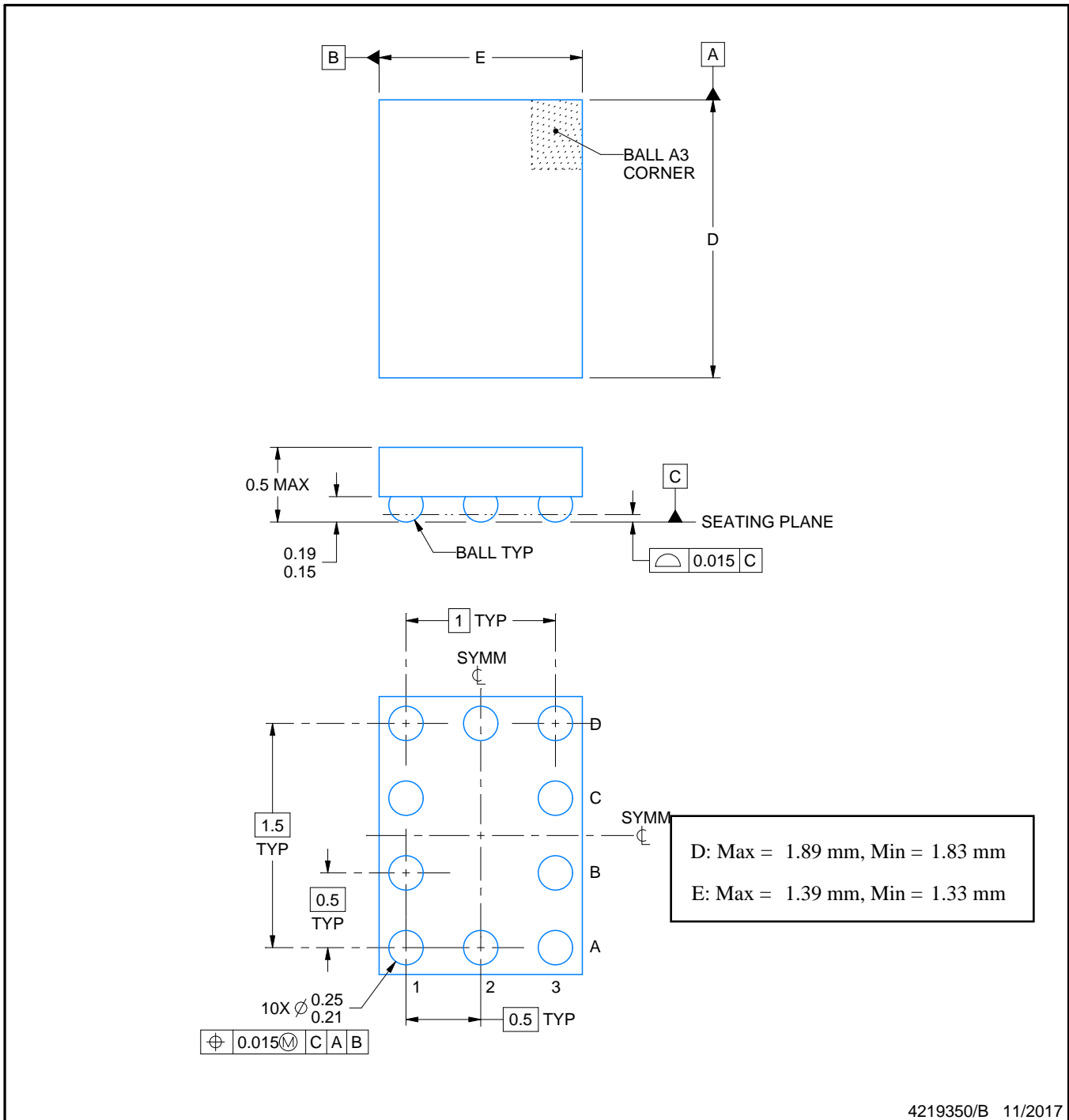

NOTES:

1. All linear dimensions are in millimeters. Any dimensions in parenthesis are for reference only. Dimensioning and tolerancing per ASME Y14.5M.
2. This drawing is subject to change without notice.

EXAMPLE BOARD LAYOUT

YZP0010

DSBGA - 0.5 mm max height

DIE SIZE BALL GRID ARRAY

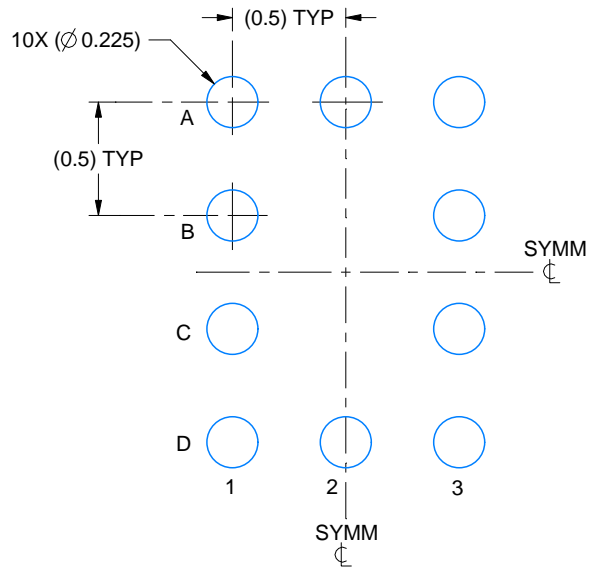

LAND PATTERN EXAMPLE
SCALE:30X

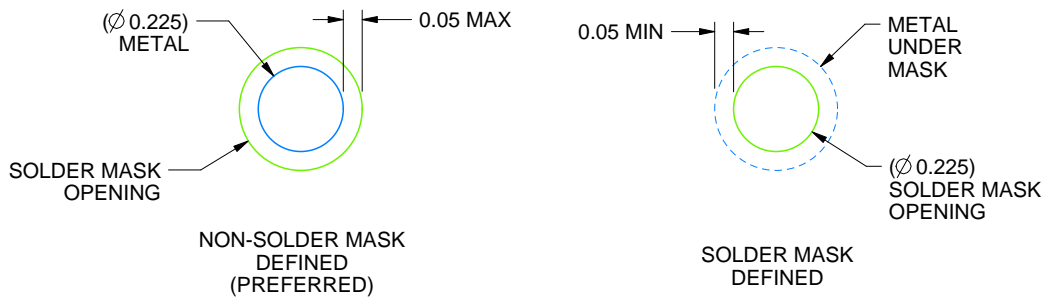

SOLDER MASK DETAILS
NOT TO SCALE

4219350/B 11/2017

NOTES: (continued)

- Final dimensions may vary due to manufacturing tolerance considerations and also routing constraints. For more information, see Texas Instruments literature number SBVA017 (www.ti.com/lit/sbva017).

EXAMPLE STENCIL DESIGN

YZP0010

DSBGA - 0.5 mm max height

DIE SIZE BALL GRID ARRAY

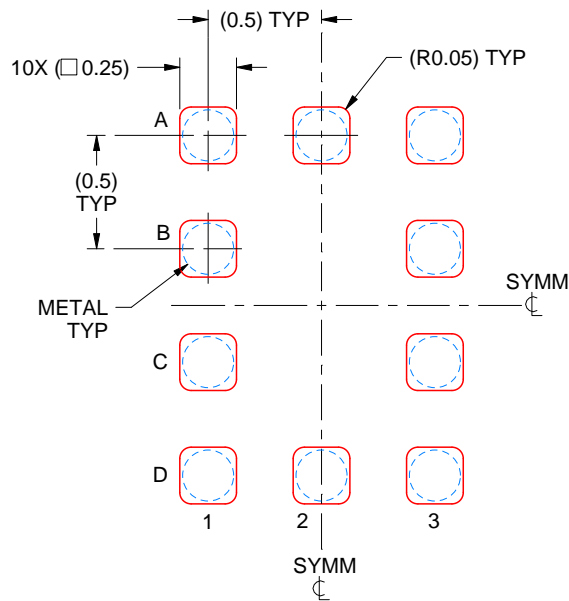

SOLDER PASTE EXAMPLE
BASED ON 0.1 mm THICK STENCIL
SCALE:30X

4219350/B 11/2017

NOTES: (continued)

4. Laser cutting apertures with trapezoidal walls and rounded corners may offer better paste release.

PACKAGING INFORMATION

Orderable Device	Status (1)	Package Type	Package Drawing	Pins	Package Qty	Eco Plan (2)	Lead/Ball Finish (6)	MSL Peak Temp (3)	Op Temp (°C)	Device Marking (4/5)	Samples
HPA02208YZPR	ACTIVE	DSBGA	YZP	10	3000	Green (RoHS & no Sb/Br)	SNAGCU	Level-1-260C-UNLIM	-40 to 85	(39 ~ 392)	Samples
TS5A22362DGSR	ACTIVE	VSSOP	DGS	10	2500	Green (RoHS & no Sb/Br)	CU NIPDAU	Level-1-260C-UNLIM	-40 to 85	39R	Samples
TS5A22362DGSRG4	ACTIVE	VSSOP	DGS	10	2500	Green (RoHS & no Sb/Br)	CU NIPDAU	Level-1-260C-UNLIM	-40 to 85	39R	Samples
TS5A22362DRCR	ACTIVE	VSON	DRC	10	3000	Green (RoHS & no Sb/Br)	CU NIPDAU	Level-2-260C-1 YEAR	-40 to 85	ZVG	Samples
TS5A22362DRCT-NM	ACTIVE	VSON	DRC	10	250	Green (RoHS & no Sb/Br)	CU SN	Level-2-260C-1 YEAR	-40 to 85	ZVGNM	Samples
TS5A22362YZPR	ACTIVE	DSBGA	YZP	10	3000	Green (RoHS & no Sb/Br)	SNAGCU	Level-1-260C-UNLIM	-40 to 85	(39 ~ 392)	Samples

(1) The marketing status values are defined as follows:

ACTIVE: Product device recommended for new designs.

LIFEBUY: TI has announced that the device will be discontinued, and a lifetime-buy period is in effect.

NRND: Not recommended for new designs. Device is in production to support existing customers, but TI does not recommend using this part in a new design.

PREVIEW: Device has been announced but is not in production. Samples may or may not be available.

OBSOLETE: TI has discontinued the production of the device.

(2) **RoHS:** TI defines "RoHS" to mean semiconductor products that are compliant with the current EU RoHS requirements for all 10 RoHS substances, including the requirement that RoHS substance do not exceed 0.1% by weight in homogeneous materials. Where designed to be soldered at high temperatures, "RoHS" products are suitable for use in specified lead-free processes. TI may reference these types of products as "Pb-Free".

RoHS Exempt: TI defines "RoHS Exempt" to mean products that contain lead but are compliant with EU RoHS pursuant to a specific EU RoHS exemption.

Green: TI defines "Green" to mean the content of Chlorine (Cl) and Bromine (Br) based flame retardants meet JS709B low halogen requirements of <=1000ppm threshold. Antimony trioxide based flame retardants must also meet the <=1000ppm threshold requirement.

(3) MSL, Peak Temp. - The Moisture Sensitivity Level rating according to the JEDEC industry standard classifications, and peak solder temperature.

(4) There may be additional marking, which relates to the logo, the lot trace code information, or the environmental category on the device.

(5) Multiple Device Markings will be inside parentheses. Only one Device Marking contained in parentheses and separated by a "~" will appear on a device. If a line is indented then it is a continuation of the previous line and the two combined represent the entire Device Marking for that device.

⁽⁶⁾ Lead/Ball Finish - Orderable Devices may have multiple material finish options. Finish options are separated by a vertical ruled line. Lead/Ball Finish values may wrap to two lines if the finish value exceeds the maximum column width.

Important Information and Disclaimer:The information provided on this page represents TI's knowledge and belief as of the date that it is provided. TI bases its knowledge and belief on information provided by third parties, and makes no representation or warranty as to the accuracy of such information. Efforts are underway to better integrate information from third parties. TI has taken and continues to take reasonable steps to provide representative and accurate information but may not have conducted destructive testing or chemical analysis on incoming materials and chemicals. TI and TI suppliers consider certain information to be proprietary, and thus CAS numbers and other limited information may not be available for release.

In no event shall TI's liability arising out of such information exceed the total purchase price of the TI part(s) at issue in this document sold by TI to Customer on an annual basis.

TAPE AND REEL INFORMATION

QUADRANT ASSIGNMENTS FOR PIN 1 ORIENTATION IN TAPE

*All dimensions are nominal

Device	Package Type	Package Drawing	Pins	SPQ	Reel Diameter (mm)	Reel Width W1 (mm)	A0 (mm)	B0 (mm)	K0 (mm)	P1 (mm)	W (mm)	Pin1 Quadrant
TS5A22362DGSR	VSSOP	DGS	10	2500	330.0	12.4	5.3	3.4	1.4	8.0	12.0	Q1
TS5A22362DRCR	VSON	DRC	10	3000	330.0	12.4	3.3	3.3	1.1	8.0	12.0	Q2
TS5A22362DRCT-NM	VSON	DRC	10	250	180.0	12.4	3.3	3.3	1.1	8.0	12.0	Q2
TS5A22362YZPR	DSBGA	YZP	10	3000	178.0	9.2	1.49	1.99	0.63	4.0	8.0	Q2

TAPE AND REEL BOX DIMENSIONS

*All dimensions are nominal

Device	Package Type	Package Drawing	Pins	SPQ	Length (mm)	Width (mm)	Height (mm)
TS5A22362DGSR	VSSOP	DGS	10	2500	358.0	335.0	35.0
TS5A22362DRCR	VSON	DRC	10	3000	367.0	367.0	35.0
TS5A22362DRCT-NM	VSON	DRC	10	250	210.0	185.0	35.0
TS5A22362YZPR	DSBGA	YZP	10	3000	220.0	220.0	35.0

DGS0010A



PACKAGE OUTLINE

VSSOP - 1.1 mm max height

SMALL OUTLINE PACKAGE



4221984/A 05/2015

NOTES:

1. All linear dimensions are in millimeters. Any dimensions in parenthesis are for reference only. Dimensioning and tolerancing per ASME Y14.5M.
2. This drawing is subject to change without notice.
3. This dimension does not include mold flash, protrusions, or gate burrs. Mold flash, protrusions, or gate burrs shall not exceed 0.15 mm per side.
4. This dimension does not include interlead flash. Interlead flash shall not exceed 0.25 mm per side.
5. Reference JEDEC registration MO-187, variation BA.

EXAMPLE BOARD LAYOUT

DGS0010A

VSSOP - 1.1 mm max height

SMALL OUTLINE PACKAGE



LAND PATTERN EXAMPLE
SCALE:10X

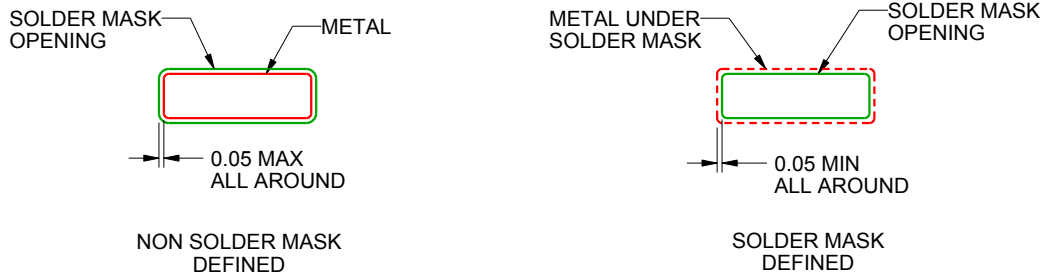

SOLDER MASK DETAILS
NOT TO SCALE

4221984/A 05/2015

NOTES: (continued)

- 6. Publication IPC-7351 may have alternate designs.
- 7. Solder mask tolerances between and around signal pads can vary based on board fabrication site.

EXAMPLE STENCIL DESIGN

DGS0010A

VSSOP - 1.1 mm max height

SMALL OUTLINE PACKAGE



SOLDER PASTE EXAMPLE
BASED ON 0.125 mm THICK STENCIL
SCALE:10X

4221984/A 05/2015

NOTES: (continued)

8. Laser cutting apertures with trapezoidal walls and rounded corners may offer better paste release. IPC-7525 may have alternate design recommendations.
9. Board assembly site may have different recommendations for stencil design.

GENERIC PACKAGE VIEW

DRC 10

VSON - 1 mm max height

PLASTIC SMALL OUTLINE - NO LEAD

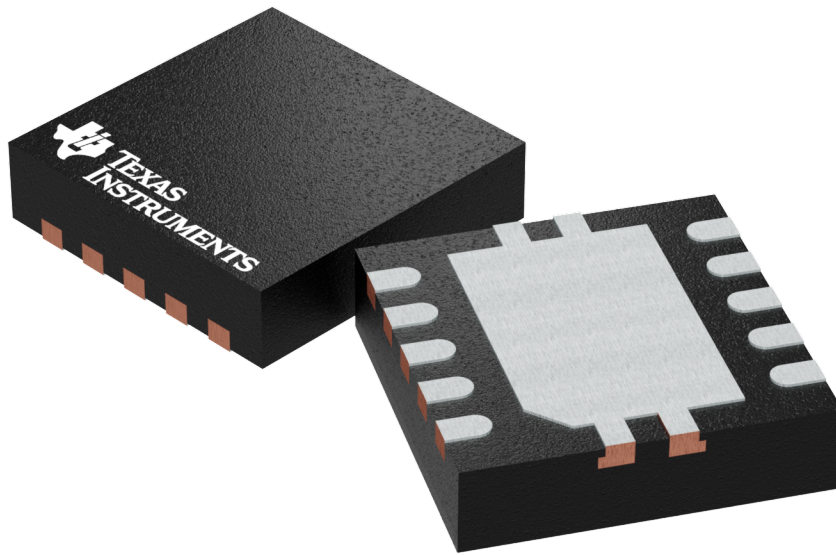

Images above are just a representation of the package family, actual package may vary.
Refer to the product data sheet for package details.

4204102-3/M

DRC (S-PVSON-N10)

PLASTIC SMALL OUTLINE NO-LEAD

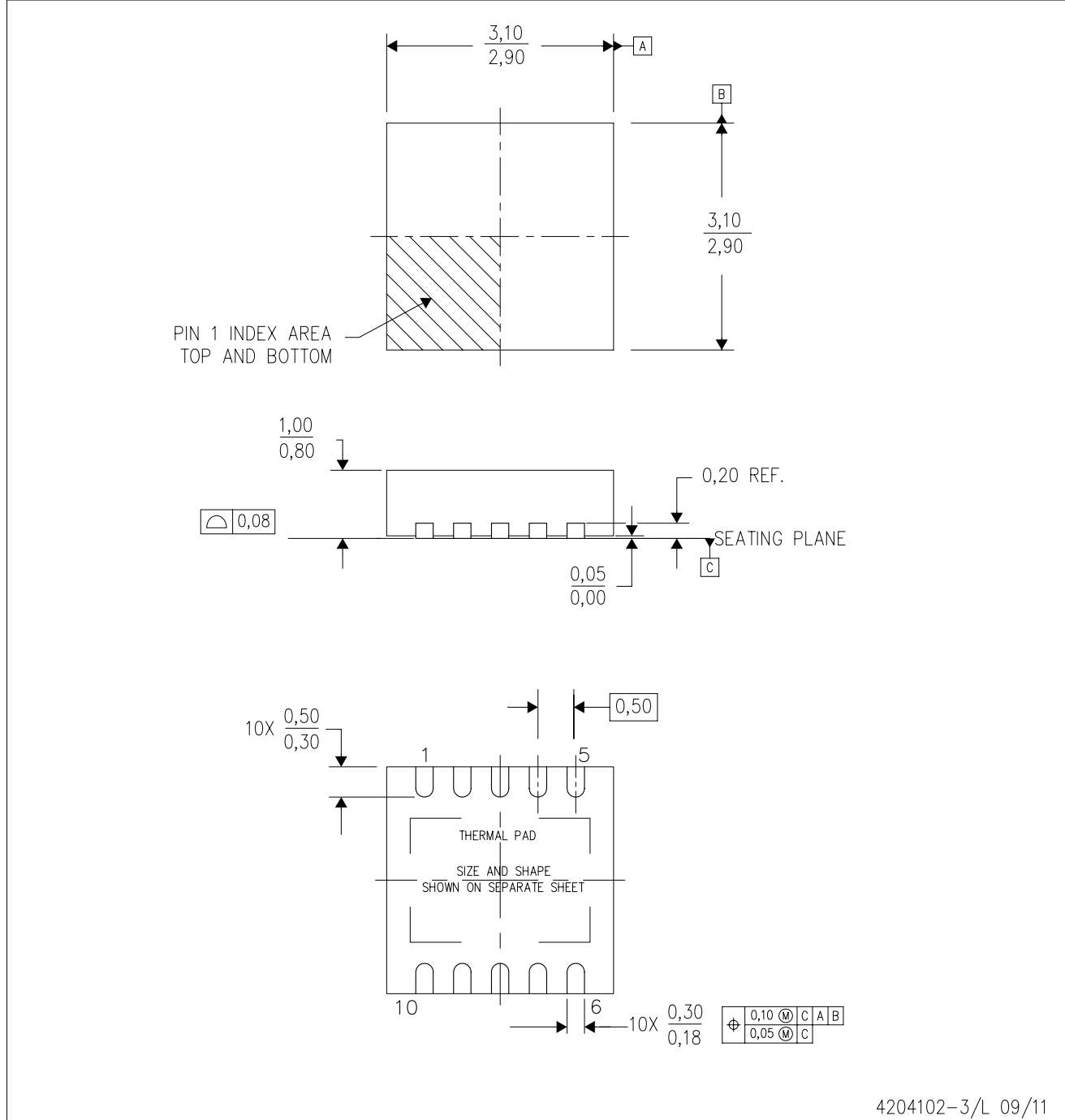

4204102-3/L 09/11

- NOTES:
- All linear dimensions are in millimeters. Dimensioning and tolerancing per ASME Y14.5M-1994.
 - This drawing is subject to change without notice.
 - Small Outline No-Lead (SON) package configuration.
 - The package thermal pad must be soldered to the board for thermal and mechanical performance, if present.
 - See the additional figure in the Product Data Sheet for details regarding the exposed thermal pad features and dimensions, if present

THERMAL PAD MECHANICAL DATA

DRC (S-PVSON-N10)

PLASTIC SMALL OUTLINE NO-LEAD

THERMAL INFORMATION

This package incorporates an exposed thermal pad that is designed to be attached directly to an external heatsink. The thermal pad must be soldered directly to the printed circuit board (PCB). After soldering, the PCB can be used as a heatsink. In addition, through the use of thermal vias, the thermal pad can be attached directly to the appropriate copper plane shown in the electrical schematic for the device, or alternatively, can be attached to a special heatsink structure designed into the PCB. This design optimizes the heat transfer from the integrated circuit (IC).

For information on the Quad Flatpack No-Lead (QFN) package and its advantages, refer to Application Report, QFN/SON PCB Attachment, Texas Instruments Literature No. SLUA271. This document is available at www.ti.com.

The exposed thermal pad dimensions for this package are shown in the following illustration.

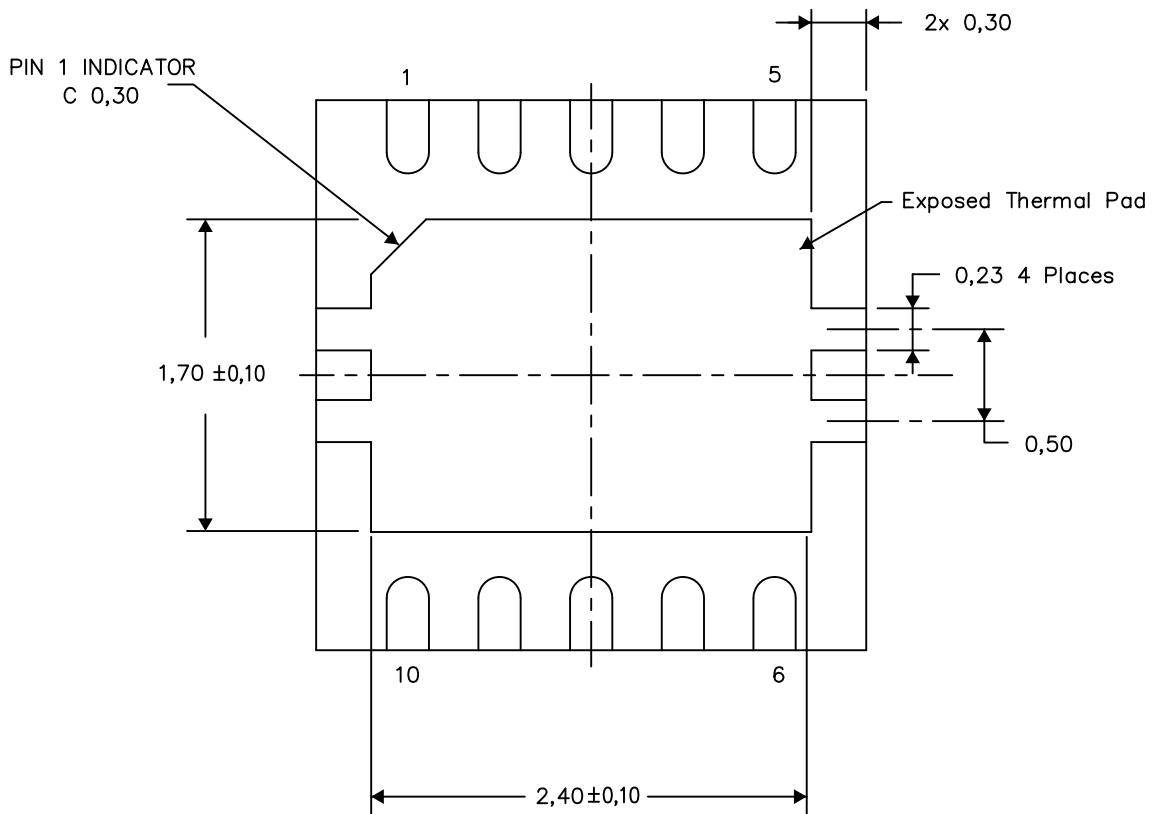

Bottom View

Exposed Thermal Pad Dimensions

4206565-8/Y 08/15

NOTE: A. All linear dimensions are in millimeters

EXAMPLE BOARD LAYOUT

DRC0010J

VSON - 1 mm max height

PLASTIC SMALL OUTLINE - NO LEAD



LAND PATTERN EXAMPLE
EXPOSED METAL SHOWN
SCALE:20X



SOLDER MASK DETAILS

4218878/B 07/2018

NOTES: (continued)

4. This package is designed to be soldered to a thermal pad on the board. For more information, see Texas Instruments literature number SLUA271 (www.ti.com/lit/sluea271).
5. Vias are optional depending on application, refer to device data sheet. If any vias are implemented, refer to their locations shown on this view. It is recommended that vias under paste be filled, plugged or tented.

IMPORTANT NOTICE AND DISCLAIMER

TI PROVIDES TECHNICAL AND RELIABILITY DATA (INCLUDING DATASHEETS), DESIGN RESOURCES (INCLUDING REFERENCE DESIGNS), APPLICATION OR OTHER DESIGN ADVICE, WEB TOOLS, SAFETY INFORMATION, AND OTHER RESOURCES "AS IS" AND WITH ALL FAULTS, AND DISCLAIMS ALL WARRANTIES, EXPRESS AND IMPLIED, INCLUDING WITHOUT LIMITATION ANY IMPLIED WARRANTIES OF MERCHANTABILITY, FITNESS FOR A PARTICULAR PURPOSE OR NON-INFRINGEMENT OF THIRD PARTY INTELLECTUAL PROPERTY RIGHTS.

These resources are intended for skilled developers designing with TI products. You are solely responsible for (1) selecting the appropriate TI products for your application, (2) designing, validating and testing your application, and (3) ensuring your application meets applicable standards, and any other safety, security, or other requirements. These resources are subject to change without notice. TI grants you permission to use these resources only for development of an application that uses the TI products described in the resource. Other reproduction and display of these resources is prohibited. No license is granted to any other TI intellectual property right or to any third party intellectual property right. TI disclaims responsibility for, and you will fully indemnify TI and its representatives against, any claims, damages, costs, losses, and liabilities arising out of your use of these resources.

TI's products are provided subject to TI's Terms of Sale (www.ti.com/legal/termsofsale.html) or other applicable terms available either on ti.com or provided in conjunction with such TI products. TI's provision of these resources does not expand or otherwise alter TI's applicable warranties or warranty disclaimers for TI products.

Mailing Address: Texas Instruments, Post Office Box 655303, Dallas, Texas 75265
Copyright © 2019, Texas Instruments Incorporated

Looking for pricing, stock, or lifecycle information?

Click below to explore more details on WIN SOURCE:

 [View TS5A22364DRCR on WIN SOURCE](#)

 [Texas Instruments](#) Information

Optimize Your Supply Chain with WIN SOURCE Solutions

-  Global Sourcing Solution
-  Obsolete Management
-  Cost Control Management
-  Shortage Management
-  Alternative Solution
-  Excess Inventory Management